

**KF Series (Field Mount type)
Pressure (Temperature)
Indicating Controller**

Model: KFP, KFT

User's Manual



Yamatake Corporation

Copyright, Notices and Trademarks

Printed in Japan - © 1998-2005 by Yamatake Corporation All Rights Reserved

While this information is presented in good faith and believed to be accurate, Yamatake Corporation disclaims the implied warranties of merchantability and fitness for a particular purpose and makes no express warranties except as may be stated in its written agreement with and for its customer.

In no event shall Yamatake Corporation be liable to anyone for any indirect, special or consequential damages. This information and specifications in this document are subject to change without notice.

Safety

Safety instructions

Preface

Correct installation and periodic maintenance are essential to the safe use of your differential pressure transmitters.

Read the safety instructions provided in this manual carefully and understand them fully before starting installation, operation, and maintenance work.

Inspection

On delivery, make sure that the specifications are correct and check for any damage that may have occurred during transportation. This equipment was tested under a strict quality control program before shipment. If you find any problem in the quality specifications, please contact your Yamatake Corporation representative immediately, providing the model name and serial number.

The name plate is mounted on the top of the enclosure.

Precautions

The following symbols are used in this manual to ensure user safety.

WARNING

Denotes a potentially hazardous situation which, if not avoided, could result in death or serious injury.

CAUTION

Denotes a potentially hazardous situation which, if not avoided, could result in operator minor injury or damage to device.

Safety messages

Installation

WARNING

- When installing the transmitter, ensure that the transmitters gaskets do not protrude from the process connection parts, such as flanges contacting the process pipes.
- Never use the transmitter in applications that are outside the rated pressure or temperature range. Always observe connection specifications. Damage to the transmitter, or leakage, may endanger plant, equipment or human safety.

CAUTION

- After installation, do not step on the transmitter as this may damage it, or cause physical injury.
- The glass indicator may break if hit with a tool or other object, and cause physical injury.
- This transmitter is heavy. During installation, please ensure that your footing is safe, and always wear safety shoes.

Maintenance

WARNING

- Before disconnecting the transmitter from the process for any reason including maintenance, wait for safe levels in residual pressure, fluid or gas. Extreme caution should be taken to avoid fluid eruption.
- Prevent burns. Check venting or draining direction, and keep plant personnel out of the way of vented gas or drained fluid.

CAUTION

Strict product controls were exercised during the manufacture of this transmitter. Never modify the transmitter in any way. In-plant modifications may result in damage to the transmitter or to property and human safety.

Table of Contents

1: Description

1-1: General	1
1-2: Structure	1
1-3: Specifications	2
1-3-1: Common specifications.....	2
1-3-2: Specifications of pressure element.....	3
1-3-3: Specifications of temperature element	3
1-3-4: Specifications of accessories.....	4

2: Indicating controller section

2-1: General	5
2-2: Descriptions of mechanisms	5
2-2-1: Deviation generating mechanism	5
2-2-2: Control mechanism.....	6
2-2-3: Manual controller unit	9
2-2-4: Pneumatic signal receiver unit (set point pointer).....	10
2-2-5: Batch switch unit.....	10

3: Installation

3-1: Air piping	11
3-2: Connection method	11
3-3: Pressure element	12
3-4: Temperature element	13

4: Operation

4-1: Preparations for operation	15
4-2: Pressure control	15
4-2-1: For liquid or gas measurement (See Figure 15 and Figure 16.).....	15
4-2-2: For steam measurement (See Figure 17 and Figure 18.)	16
4-3: Manual operation	18
4-4: Automatic operation	18
4-5: Unusing the rate action	19
4-6: Setting of batch switch	19

5: Calibration and adjustment

5-1: Deviation generating mechanism	20
5-2: Controller mechanism	21
5-2-1: Balance adjustment for controller proportional band	21
5-2-2: Calibration of reset and rate units.....	22
5-2-3: Other calibration and adjustment procedures	24
5-3: Adjustment of set point indication	27
5-4: Transmitter unit	28

Table of Contents

5-5: Detecting element	29
5-5-1: Pressure element.....	29
5-5-2: Temperature element	30

6: Maintenance and troubleshooting

6-1: Routine inspection	31
6-2: Controller unit	32
6-3: Pilot relay	33
6-4: Removing the AUTO unit when in manual operation	34
6-5: Troubleshooting	35

1: Description

1-1: General

The KF series field mount type indicating controllers measure and indicate various types of process variable (PV) and, at the same time, they compare the process variable with the set point (SP) and generate a pneumatic control output signal of 20 to 100 kPa {0.2 to 1.0 kgf/cm²}.

Setting of the set point value can be done either in the local mode with the manual setting knob (this knob is adjustable either inside the casing or from outside of the casing) or in the remote mode with an external pneumatic signal. These instruments also can transmit a pneumatic signal of 20 to 100 kPa {0.2 to 1.0 kgf/cm²} which is corresponding to the measured process value.

The only difference between pressure measuring instruments and temperature measuring instruments is their sensor element.

1-2: Structure

The KF instrument is comprised of three major units, namely, casing, circuit board on which various units are mounted, and pressure sensor (or temperature sensor).

1-3: Specifications

1-3-1: Common specifications

Indication	Accuracy of indication	$\pm 1\%$ F.S.
	Indicating angle	44°
	Scale length	150 mm
Setting	Manual setting	Inside or outside of the case
	External air pressure setting	20 to 100 kPa {0.2 to 1.0 kgf/cm ² }
Control action	P + Manual reset, PI, PID PD + Manual reset, PID, PI + Batch switch, PID + Batch switch, P + External reset, PD + External reset, ON-OFF action, Differential gap operation; Direct or reverse action available for all actions.	
	Proportional band	5 to 500%
	Integral time	0.05 to 30 min.
	Derivative time	0.05 to 30 min.
	Differential gap	1 to 100%
	Manual reset	20 to 100 kPa {0.2 to 1.0 kgf/cm ² } air pressure setting
	Batch switch	Set pressure 60 to 110 kPa {0.6 to 1.1 kgf/cm ² }
	Air pressure specifications	Supply air pressure
	Controller output;	20 to 100 kPa {0.2 to 1.0 kgf/cm ² } (Load $\phi 4 \times 3$ m + 20 c.c.min.) 0 or supply air pressure (on-off, differential gap)
	Connection	Rc1/4 (PT1/4) or 1/4NPT, female
Air consumption	4 ℓ /min(N) (at 50% equilibrium)	
Output air pressure gauge	0 to 200 kPa {0 to 2 kgf/cm ² }, 40 mm	
Ambient temperature range	-30 to 80°C	
Ambient humidity range	10 to 90% RH	
Case, door	Water proof type	Equivalent to JIS F 8001, Class III splash proof, IEC IP54, NEMA3
	Case	Aluminium diecasting, dark beige, acryl baking
	Door	Glass fiber reinforced polyester resin, dark beige
Weight	Approx. 5.5 kg (for PI indicating controller, excluding the element)	

1-3-2: Specifications of pressure element

Measuring range	Bellow type	-101.3 to 0 kPa {-760 to 0 mmHg} to 0 to 200 kPa {0 to 2 kgf/cm ² }
	Spiral bourdon type	0 to 300 kPa {0 to 3 mmHg} to 0 to 35 MPa {0 to 350 kgf/cm ² }
	Bellows receiving air pressure type	20 to 100 kPa {0.2 to 1.0 kgf/cm ² }
Material	SUS316 Bellows receiving air pressure type is phosphorus bronze.	
Connection	Process	G1/4 (RF1/4) female
	Pneumatic signal	Rc1/4 (PT1/4) or NPT1/4 female

1-3-3: Specifications of temperature element

Measuring range	-50°C to +50°C min. ~ 0°C to +500°C max.	
Material sealed	Measuring range	Material sealed
	0 ~ 50	Kerosine
	0 ~ 100	
	0 ~ 150	
	0 ~ 200	Silicon
	0 ~ 300	
	0 ~ 400	
	0 ~ 500	N ₂ gas
	50 ~ 100	
	100 ~ 200	Silicon
	100 ~ 300	
	100 ~ 400	
	-50 ~ 50	Ethyl alcohol
	-50 ~ 100	Silicon
Material for wetted section	Heat sensitive section	SUS304
	Protecting tube	SUS316, SUS316L or SUS304 Refer to “3-4: Temperature element” on page 13 for details
	Material for lead and armored tube	SUS304

1-3-4: Specifications of accessories

Transmitter mechanism	Transmitting air pressure	20 to 100 kPa {0.2 to 1.0 kgf/cm ² } (load $\phi 4 \text{ mm} \times 3 \text{ mm} + 20 \text{ c.c.min.}$)
	Air consumption	4 $\ell/\text{min(N)}$
Manual operation unit:	Balance-bumpless type	
	Manual pressure setting range	10 to 130 kPa {0.1 to 1.3 kgf/cm ² }
	Air consumption	3 $\ell/\text{min(N)}$
Air set:	Pressure regulator valve with filter 40 mm, 0 to 200 kPa {0 to 2 kgf/cm ² } pressure gauge	
	Maximum primary pressure	970 kPa {10 kgf/cm ² }
	Air consumption	0.95 $\ell/\text{min(N)}$ (at output pressure 140 kPa {1.4 kgf/cm ² })
Protecting tube:	Use only for the temperature indicating controller	
	Flange type	JIS 10K, 20K, ANSI 150, 300
	Screw-in type	R3/4, 1 (PT3/4, 1)

2: Indicating controller section

2-1: General

The free end of the sensor element is displaced in proportion to the measured process value. The displacement is fed through a linkage to the deviation generating mechanism which magnifies and indicates the deviation on the scale. At the same time, through another linkage, the control deviation amount is fed to the controller unit which performs the proportional, reset and rate actions on the deviation amount in order to produce a pneumatic control output signal.

2-2: Descriptions of mechanisms

2-2-1: Deviation generating mechanism

The deviation generating mechanism consists of a deviation detecting section and an indicator section. It detects the deviation of the measured value of the process variable (PV value indicated by the measuring pointer on the scale) from the set point value (SP value indicated by the set point pointer) and controls the position of the flapper with respect to the nozzle via a control link.

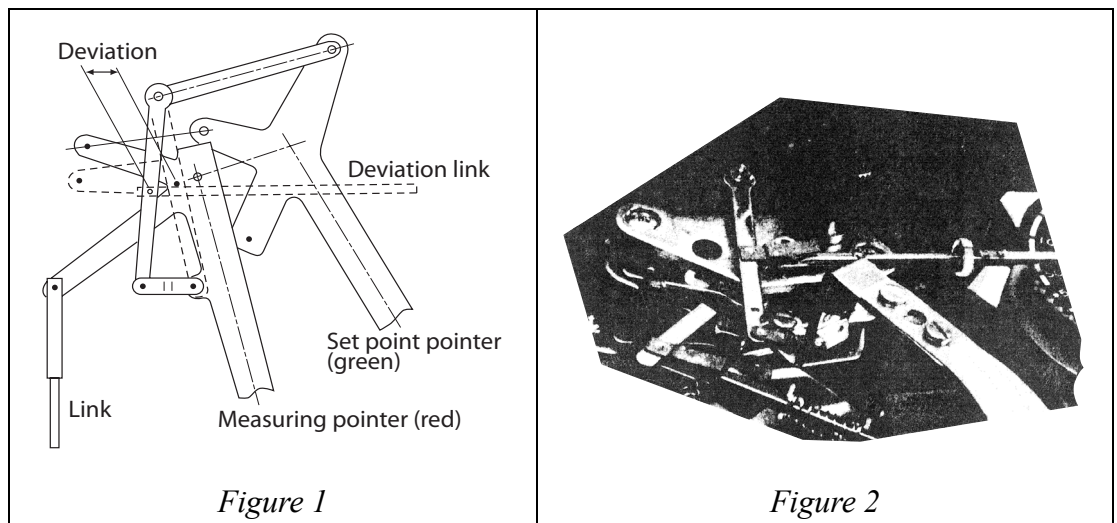

2-2-2: Control mechanism

The control mechanism consists of a controller unit, a reset unit, and a rate unit. Different combinations of these units are possible to attain different control actions.

Controller unit

Displacement of the deviation link is fed via the flapper pin of the feedback link to the flapper, so that its gap with respect to the nozzle is varied and consequently the nozzle back pressure is varied. The nozzle back pressure is boosted by the pilot relay and delivered as the pneumatic output signal of the controller. This output signal is led to the feedback chamber in order to return the flapper-to-nozzle gap to that existed before this displacement took place. Ultimately the controller output pressure is balanced at a value in a certain proportion to the deviation.

Setting of proportional band can be done by turning the proportional band dial which varies the crossing angle between flapper and deviation link (feedback link).

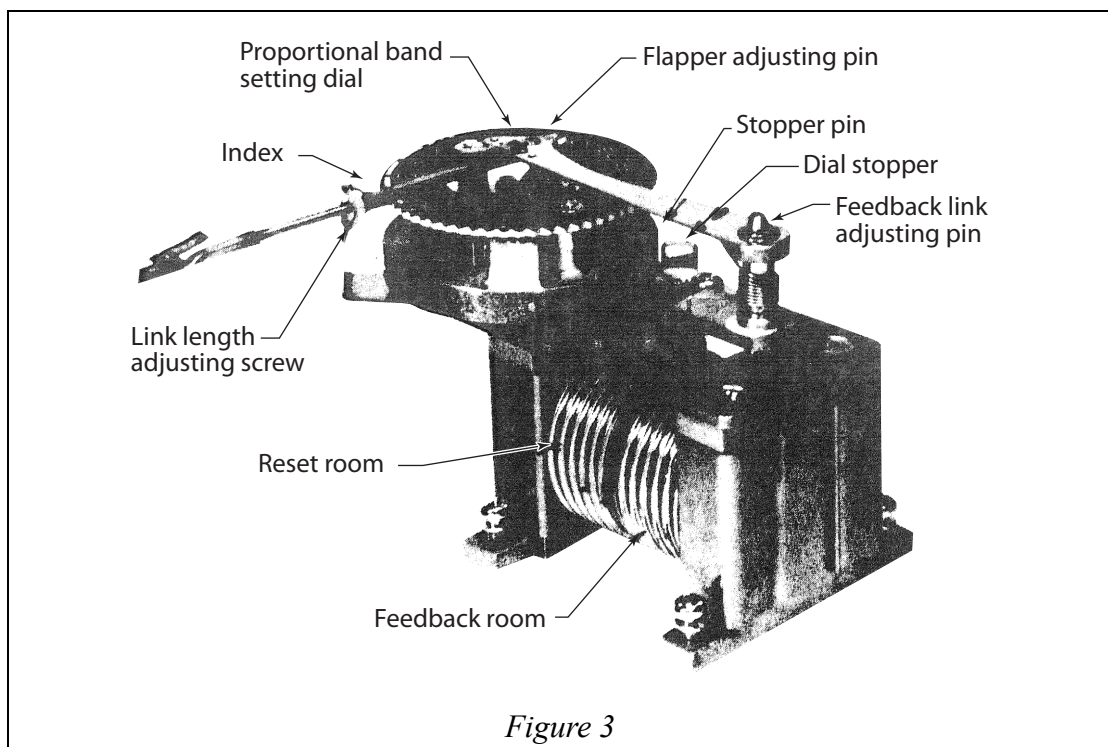

Reset unit (integrating unit)

Pneumatic pressure of the feedback chamber is fed to the reset chamber through capacity and restriction of the reset unit. Thereby attaining a reset action. When the rate unit is provided, a derivative action also can be attained. A bellows is provided in the chamber of the rate unit and part of the controller output pressure is directly led to this bellows to adjust the amplitude of the derivative action.

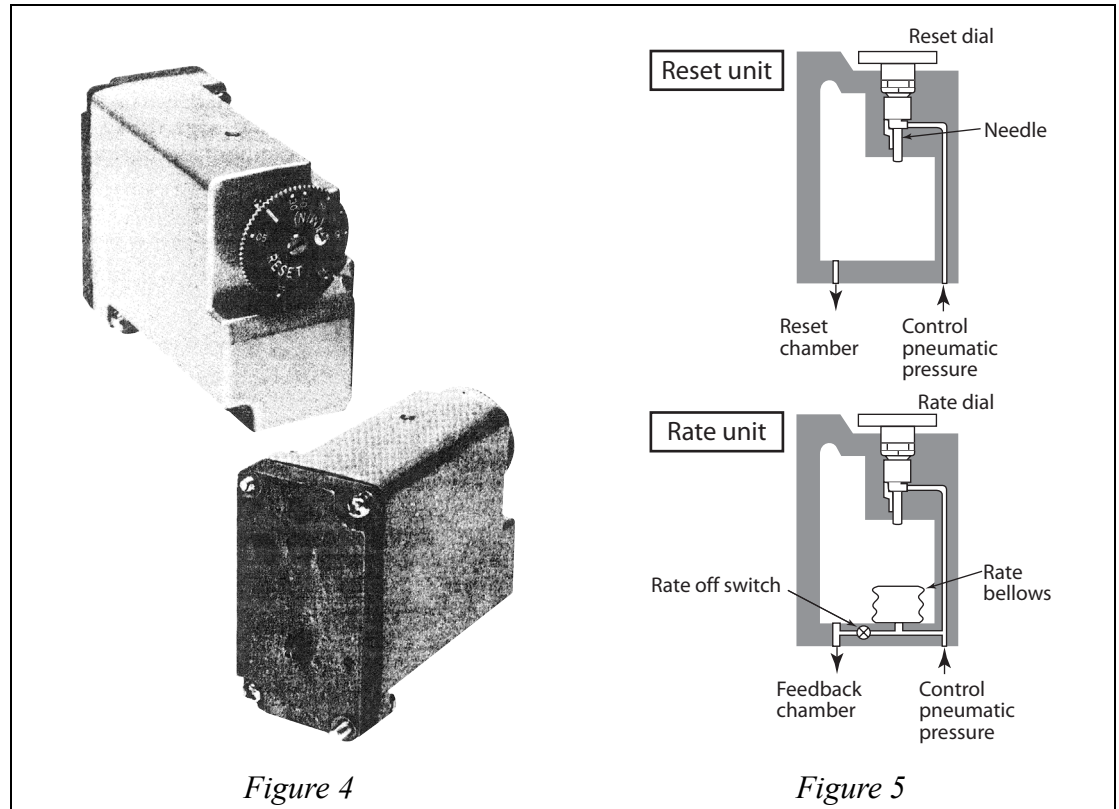

Figure 4

Figure 5

Other control operations

(a) On-Off action

The nozzle back pressure is directly applied to the pilot relay.

The control operation is done in an ON-OFF mode in response to the open or closed state of the nozzle.

(b) Differential gap action

The feedback chamber of the controller unit is replaced with a spring-function device and the output pressure is led to the reset chamber. The differential gap width is adjustable as required.

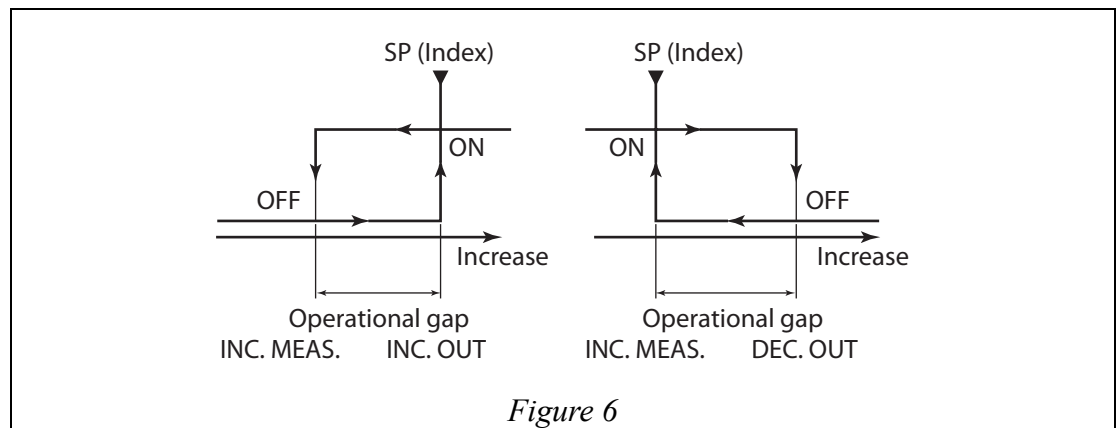

Figure 6

(c) Additional of manual reset

Such manual reset provisions can be incorporated that the output pressure of the pilot relay is applied to the feedback chamber of the controller unit and the manual reset pressure produced by a pressure regulator is applied to the reset chamber.

(d) Addition of external reset

This provision is such that a reset signal as explained in the above item (c) is applied externally. The external signal can be applied through the RES port of the customer connection block.

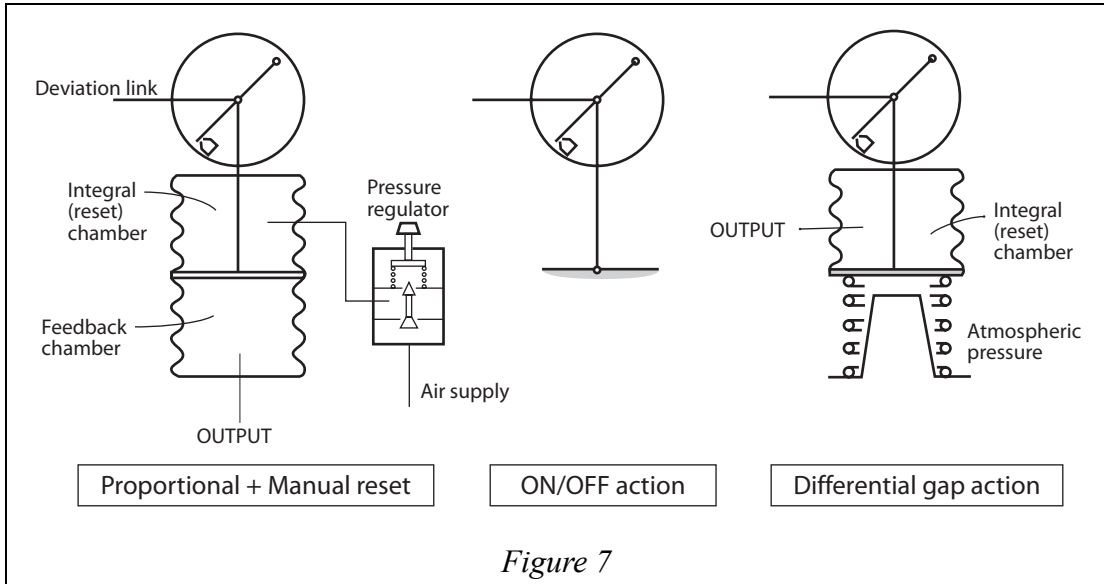

2-2-3: Manual controller unit

The manual controller unit consists of a pressure regulator for manual pressure setting and an AUTO/MAN transfer switch.

When in the automatic mode (the lever is set in the A position), the output air pressure gauge indicates the automatic control output pressure; when the check button is pressed, the gauge indicates the regulator output pressure (manual controller output pressure).

When in the manual mode (the lever is set in the M position), the output pressure of the regulator is led to the reset chamber of the controller unit and, at the same time, it is indicated by the output pressure gauge and applied to the control valve for remote control operation. If the check button is pressed in this case, the pressure gauge indicates the controller output pressure.

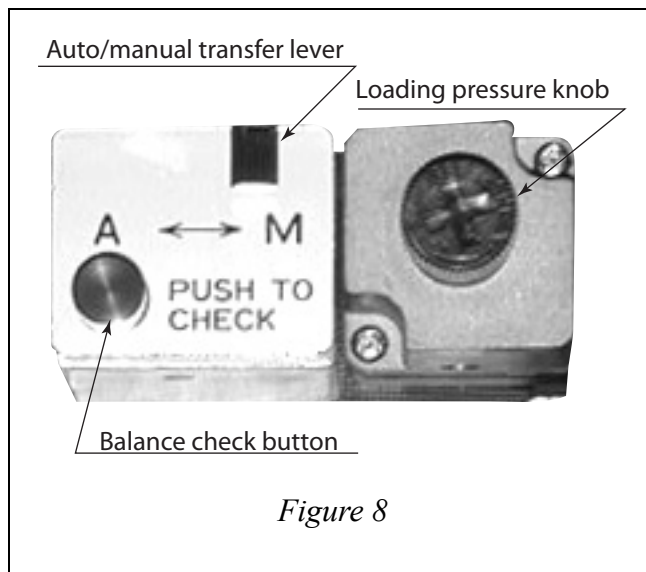

Figure 8

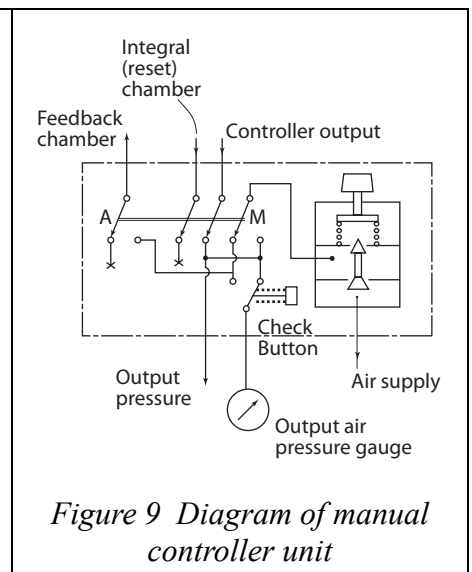
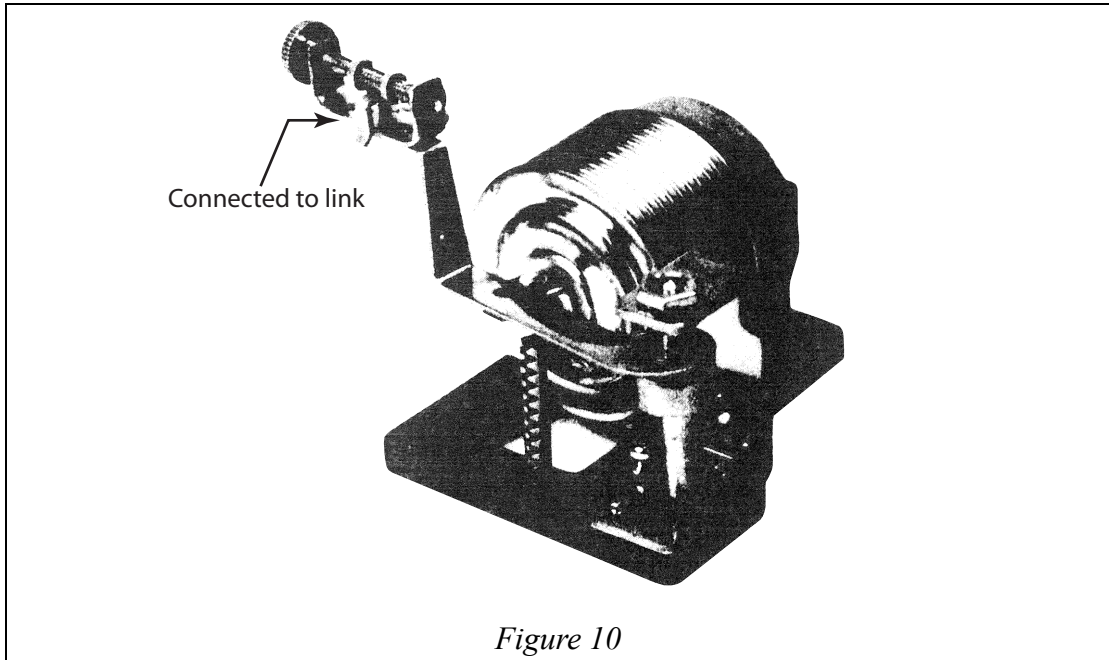

Figure 9 Diagram of manual controller unit

2-2-4: Pneumatic signal receiver unit (set point pointer)

This unit receives with its bellows an external pneumatic signal of 20 to 100 kPa {0.2 to 1.0 kgf/cm²} and converts this pneumatic signal into a mechanical position displacement. This displacement is conveyed via a travel link to the deviation generating mechanism which magnifies the displacement so that the input signal is indicated as a set point signal on the indicator scale.



2-2-5: Batch switch unit

When the output has exceeded a preset limit, a relay trips so that the reset pressure cannot increase above the preset limit. This unit is used to prevent abnormal excursion of signal when starting operation of a batch process. (This unit is effective only for control of high limit.)

Preloading for a batch process can be done by applying an external preload pressure to the connector block (RES port) of the instrument.

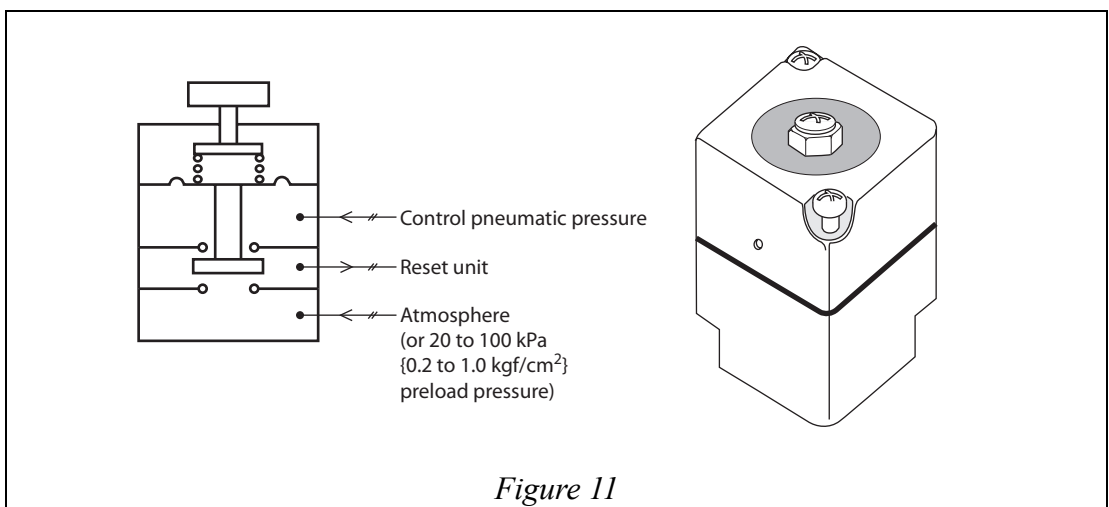

3: Installation

For installation and connections of the instrument, see the drawings of instrument mounting dimensions.

3-1: Air piping

For piping, use copper pipes of OD 6 mm (ID 4 mm) with brass fittings HI-ZEX tubes. (HI-ZEX: Tradename of polyethylene tubes manufactured by Mitsui Petrochemical Ind. Ltd.)

Air supply

- (a) The air supply must be clean, dry air of 140 ± 14 kPa $\{1.4 \pm 0.14$ kgf/cm² $\}$. Connect the air supply to the instrument via a filter and a pressure regulator. When two or more instruments are used, provide a filter and a regulating valve for each instrument.
- (b) Connect the supply air to the SUP port of the air connection manifold of the instrument.

~Note Use of pipe sealing agent may be harmful to pipes. If sealing agent is required, sparingly apply it to the male connector.

Output air

Connect the pipe for the control valve to the OUT port of the air connection manifold of the instrument.

3-2: Connection method

- (1) The air connection ports at the bottom of the instrument casing are as shown below. Both Rc1/4 (PT1/4) thread and 1/4NPT thread are provided for each connection item. Seal the unused ones with plugs.
- (2) If an air set is provided, connect the air supply to the IN port of the air.

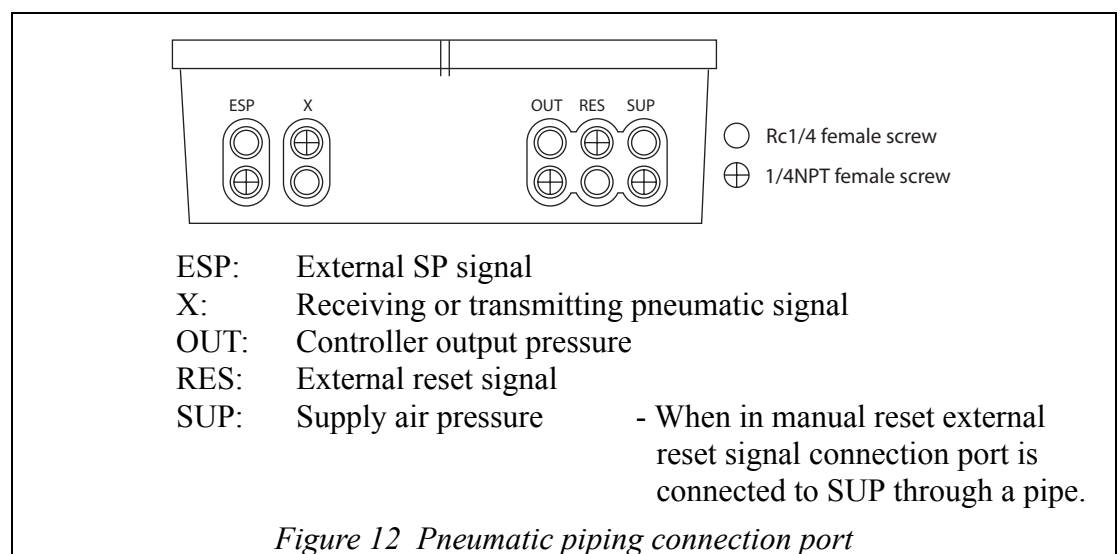

3-3: Pressure element

The connection port (G1/4 (PF1/4), female) for the process pressure piping is located on the bottom of case.

Proper piping may differ depending on the process condition and the instrument installation. Generally, attention should be paid to the following points.

- (1) Provide a stop valve in the pressure connection tube so as to allow maintenance operation without interrupting the process.
- (2) Provide a cock for drain and air release. In case of a horizontal piping, provide a gradient of 1/100 or more.
- (3) If the process pressure largely pulsates or varies, provide a pulsation preventing means to smooth out pressure. (Please consult your Yamatake representative on a special case.)

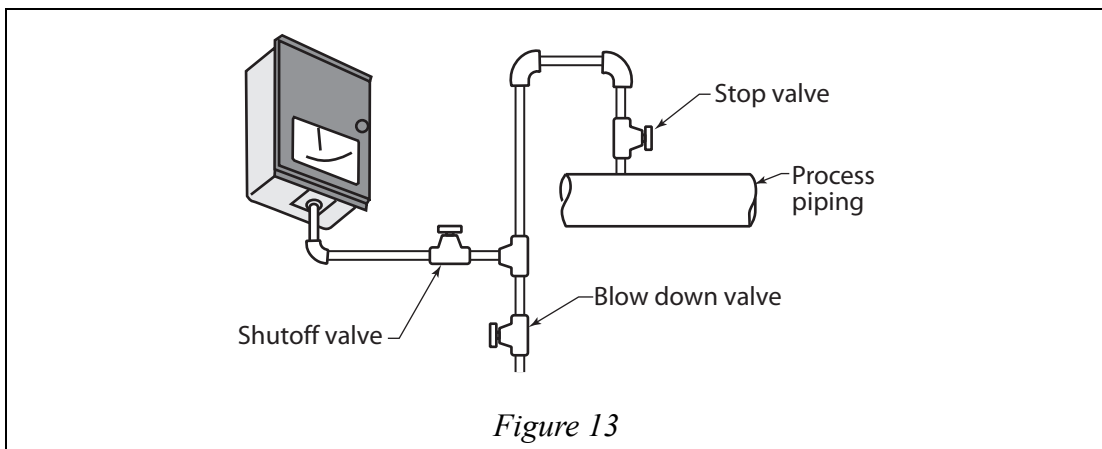

3-4: Temperature element

The temperature element consists of a heat sensing section, a capillary section and a displacement converting section. Entire system is compensated for ambient temperature change.

- (1) The capillary and an armored tube covering it shall have a bending radius of 60 mm over to avoid excessive stress.
- (2) Select proper type of the heat sensing element depending on the condition of measured fluid and the type of process vessel.
- (3) To measure temperature of a fluid flowing in a process pipe, locate the heat sensing section in the center of the pipe and along the fluid flow whenever possible.

~Note Pay attention to the mounting method and the inserted length of the sensing bulb (protecting tube) so that no abnormally large force is applied to it, in case where measured fluid of 400°C or more has higher viscosity, where flow rate exceeds 3 m/sec., or where Carman's vortex is generated.

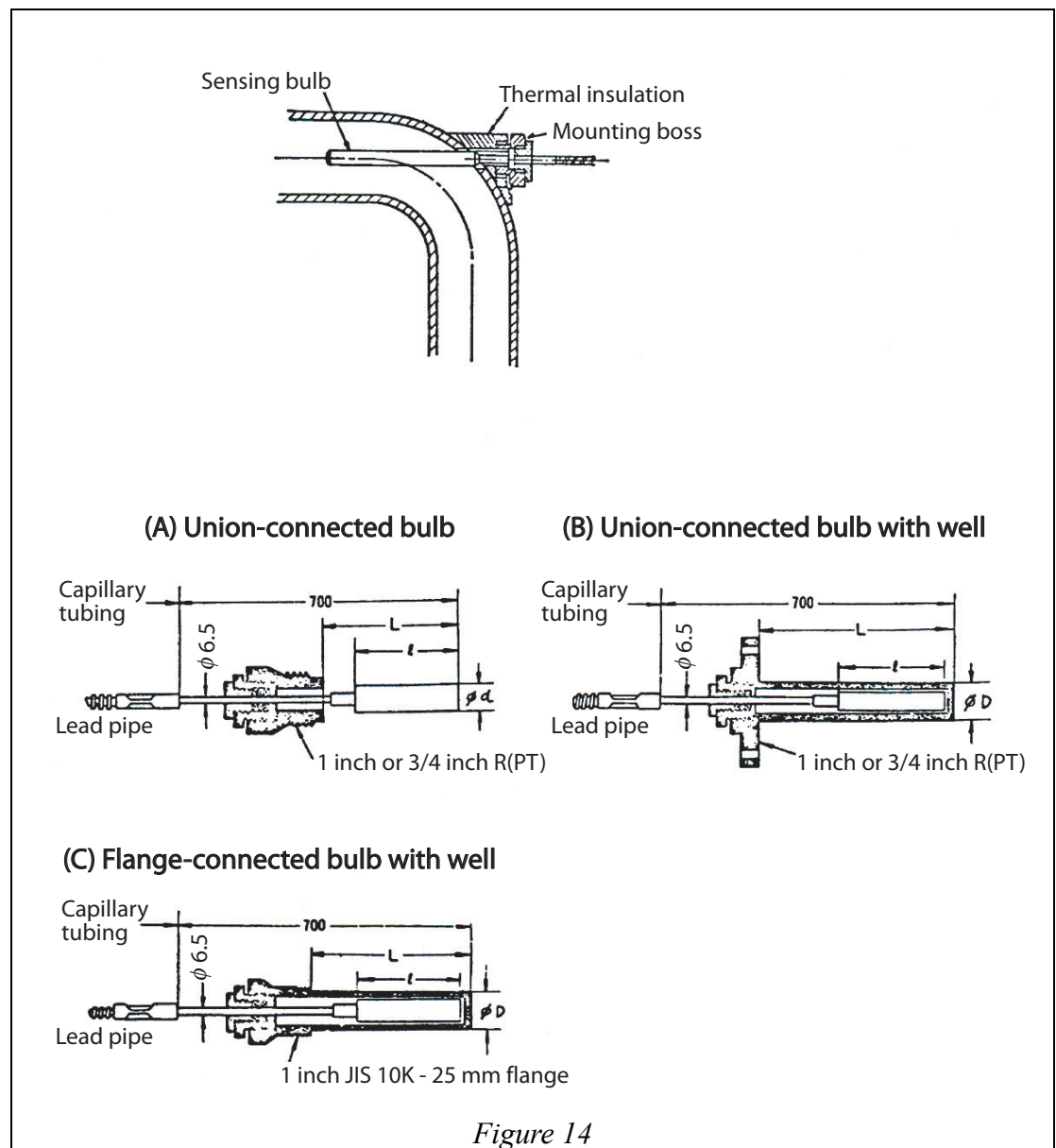

Figure 14

Temperature range (C)	Heat sensing section length	Heat sensing section diameter (d mm) Protecting tube diameter (D mm)	Length below screw (below flange)		Specification of screw	Flange ratings
			Min.	Max.		
0 ~ 50	145	d = 12.7, D = 17	200	1000	R1 (PT1) or R3/4(PT3/4)	JIS 10K 25 mm
50 ~ 100						
-50 ~ 50	83					
0 ~ 100						
-50 ~ 100	66					
0 ~ 150						
100 ~ 200	83					
0 ~ 200	45					
100 ~ 300						
0 ~ 300	35					
100 ~ 400	260	d = 22, D = 27	300	R1(PT1) or 1NPT	JIS 10K, 20K 40 mm	
0 ~ 400					ANSI 150, 300 1½ mm	
0 ~ 500						

4: Operation

4-1: Preparations for operation

- (1) Check that air piping is correctly done and there is no air leak.
- (2) If a manual loader is used, turn the lever to “M” (to the extremely counterclockwise position) to make the regulator output zero.
- (3) Drain the filter and set the supply air pressure at 140 kPa {1.4 kgf/cm²}.

4-2: Pressure control

- (1) Close the stop valve when starting-up the process.
- (2) After inspecting the process system piping for leakage, close the blow-down valve and open the stop valve to start-up the operation.

4-2-1: For liquid or gas measurement (See Figure 15 and Figure 16.)

In case of the clean and non-corrosive liquid, observe the following instruments for operation of the instrument.

- (1) Open the bleed valve while keeping the block valve closed. Then open the stop valve to blow away foreign materials from inside the pressure connection tube.
- (2) When the pressure connection tube is cleaned, close the blow-down valve. If the temperature of pressure medium is high, wait until the tube is cooled off and then open the shutoff valve to start the operation.

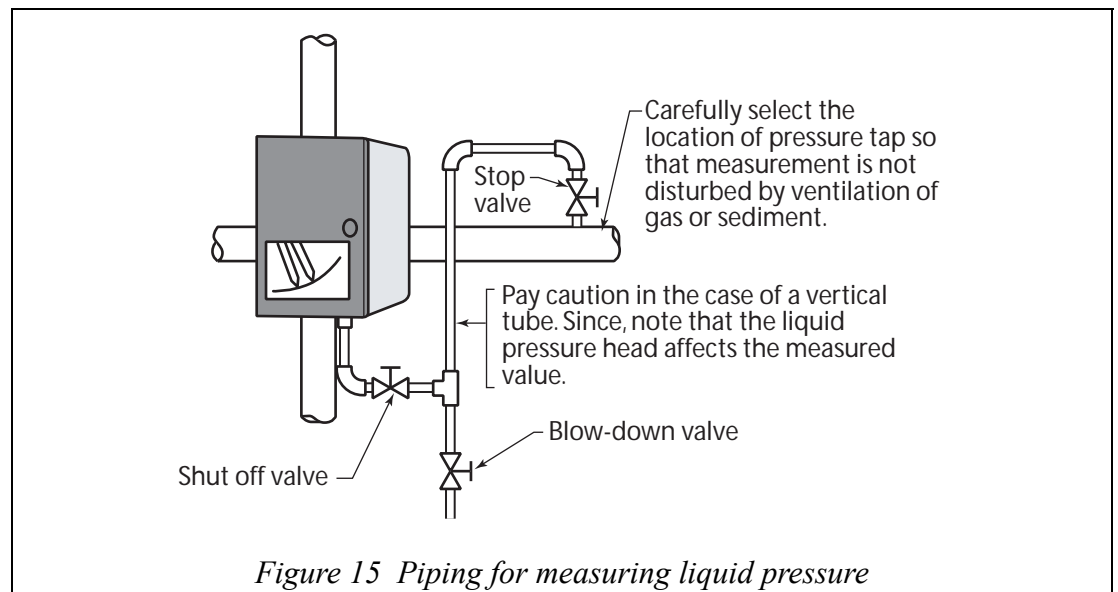

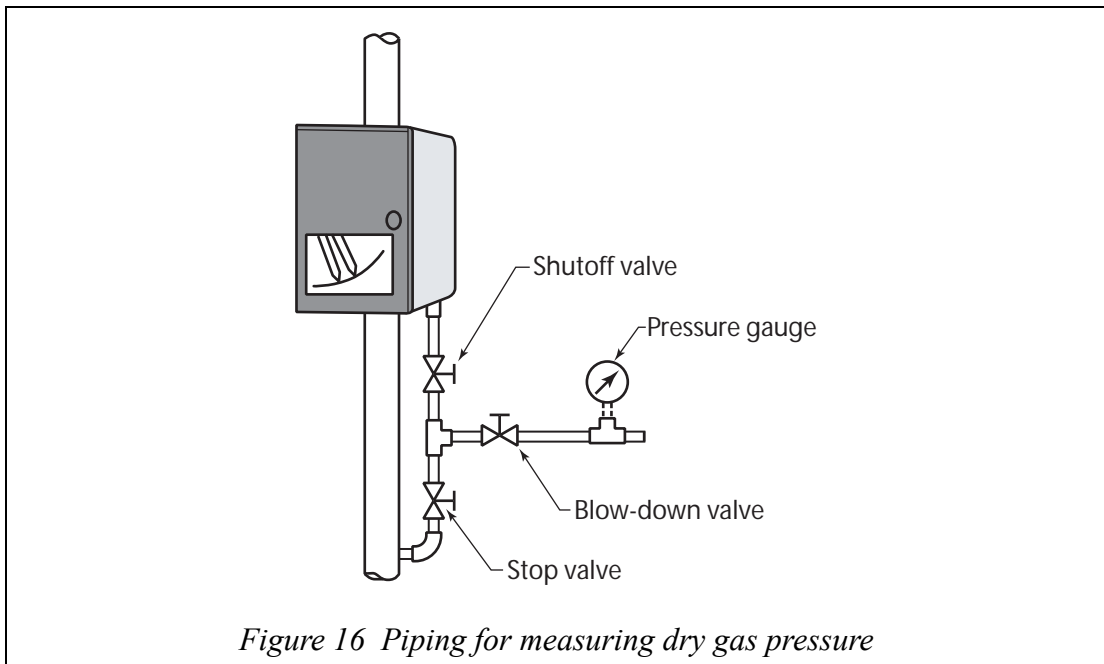

4-2-2: For steam measurement (See Figure 17 and Figure 18.)

- (1) Open the blow-down valve keeping the shutoff valve closed. Then open the stop valve to blow a way foreign materials from inside the tube.
- (2) Close the blow-down valve. Condense the vapor to fill the pressure tap tube and the siphon. Open the shutoff valve to start-up the operation.

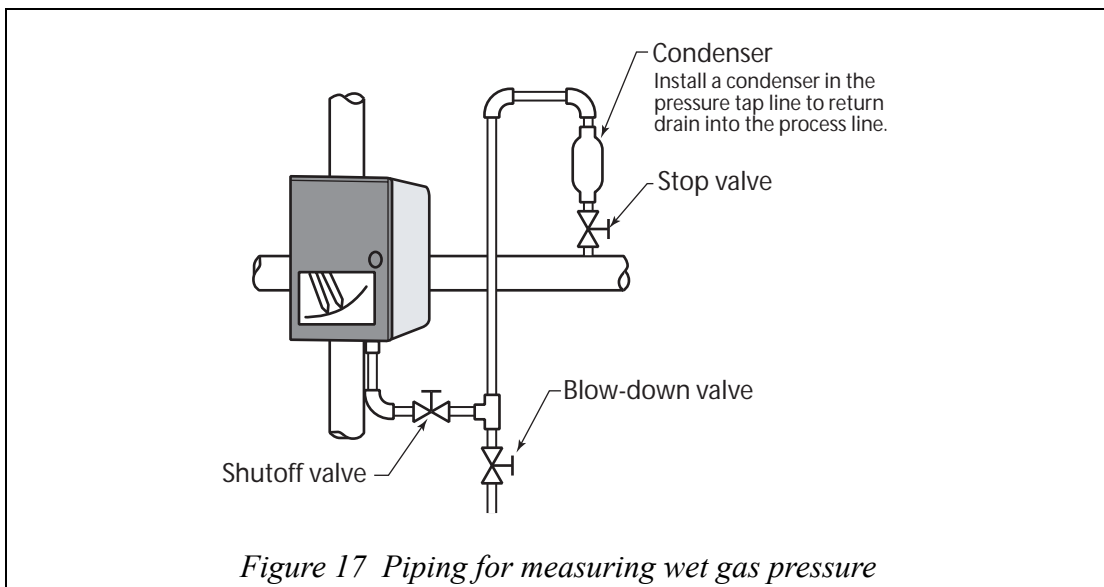

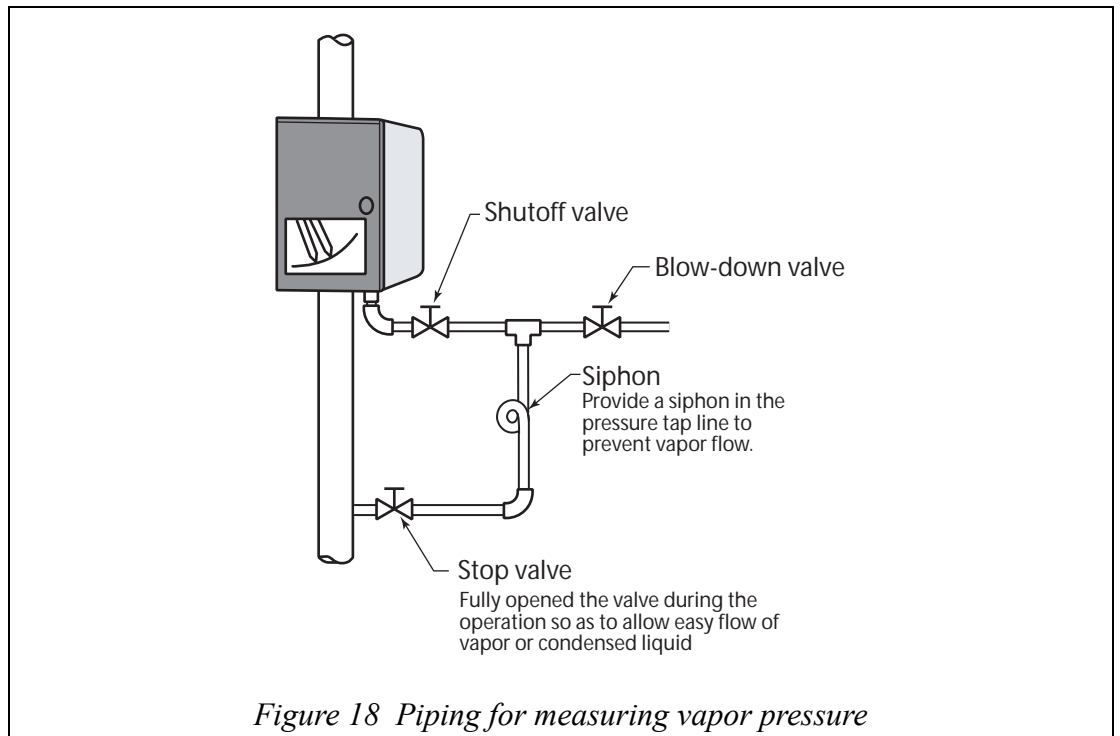

4-3: Manual operation

When a manual loader is provided, perform the manual operation according to the following procedure to conform the stability of process.

- (1) Set the AUTO/MAN transfer switch in the M position. Adjust the manual loader (regulator) output so that the required process value is obtained.

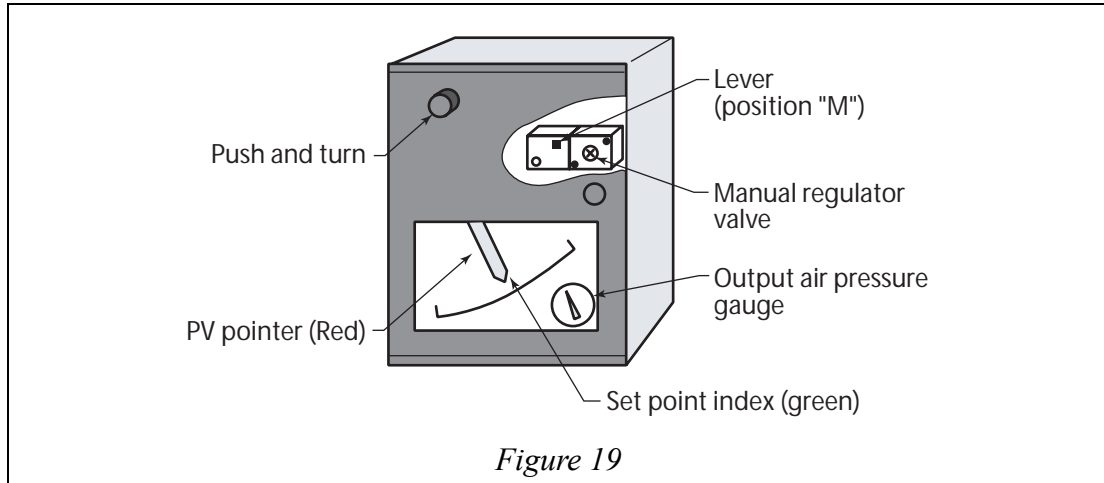

4-4: Automatic operation

For a control system for which no set point value is determined, automatic operation is generally started in the procedure mentioned below.

- (1) Set the control sections as follows:
 - Proportional band (P): Maximum (proportional band setting dial 500%)
 - Reset time (I): Maximum (reset dial 3.0 minutes)
 - Rate time (D): Minimum (rate dial 0.05 minutes)
- (2) When the manual loader unit is provided, operate the pressure regulator so that the desired output value can be obtained with the AUTO/MAN switch set in the M position.
- (3) By turning the setting knob, set the set point pointer to the desired value. When the setting knob outside the case is provided, setting can be done by turning the knob, pressing it toward the door.
- (4) If the check button is pushed with the AUTO/MAN switch set in the manual (M) position, the output pressure gauge indicates the controller output. If the check button is pushed with the switch set in the automatic (A) position, the pressure gauge indicates the pressure regulator output.

For switching from the manual operation to the automatic operation when the manual loader is provided, make equal the pressure regulator output and the controller output in the manual (M) position, observing the output pressure gauge. When the pointer of the output pressure gauge has become stable even if the check button is pushed, change the transfer switch lever from manual (M) position to auto (A) position. (Shift the lever quickly and completely until it comes to the end position.)
- (5) In auto operation, set P.I.D. to suit the process characteristics.
- (6) For switching to manual operation, follow in the reverse order the procedure (4)

4-5: Unusing the rate action

To unuse the rate action with the rate unit mounted, turn the rate off switch on the unit fully counterclockwise. This feature is convenient when adjusting the controller mechanism.

When rate action is required, turn the rate off switch fully clockwise.

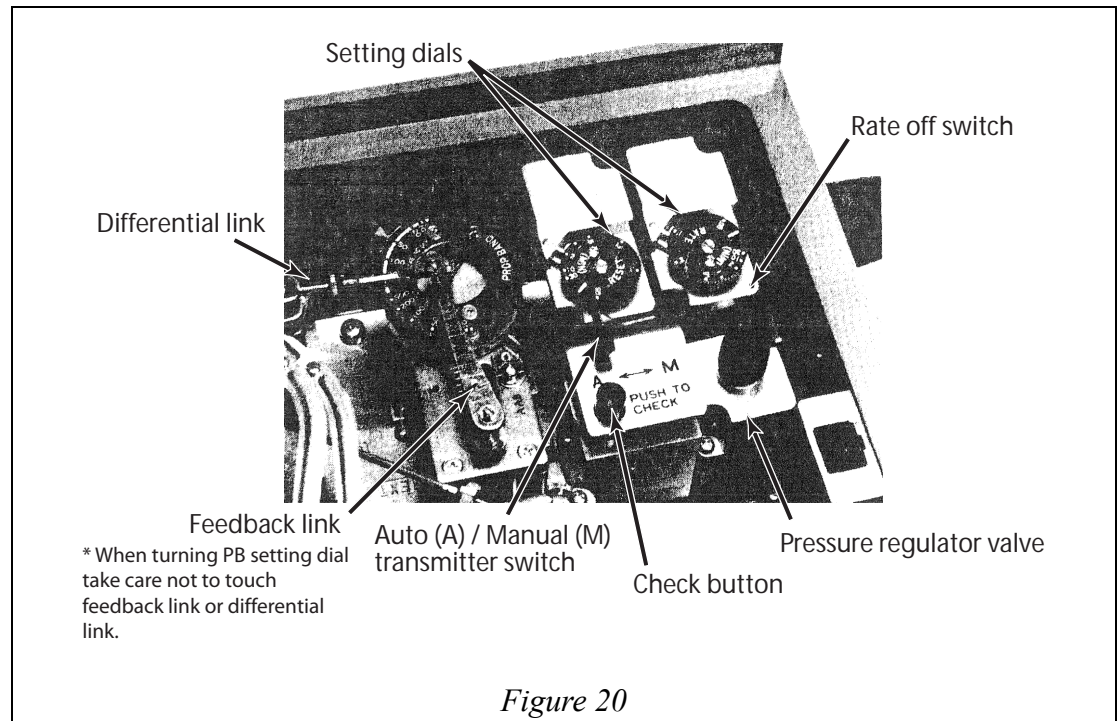

4-6: Setting of batch switch

- (1) Connect the controller output to a pressure gauge
- (2) Perform the following settings and apply a deviation input to saturate the output.
Proportional band: 50%
Reset time: 0.02 min.
- (3) Decrease the output to the desired value by turning the setting screw. The output decreases as the screw is turned clockwise.
- (4) When the function as a batch controller is not required, turn the setting screw fully counterclockwise.

5: Calibration and adjustment

5-1: Deviation generating mechanism

By following the procedure mentioned below, accurately align the ends of the measuring pointer and the set point pointer.

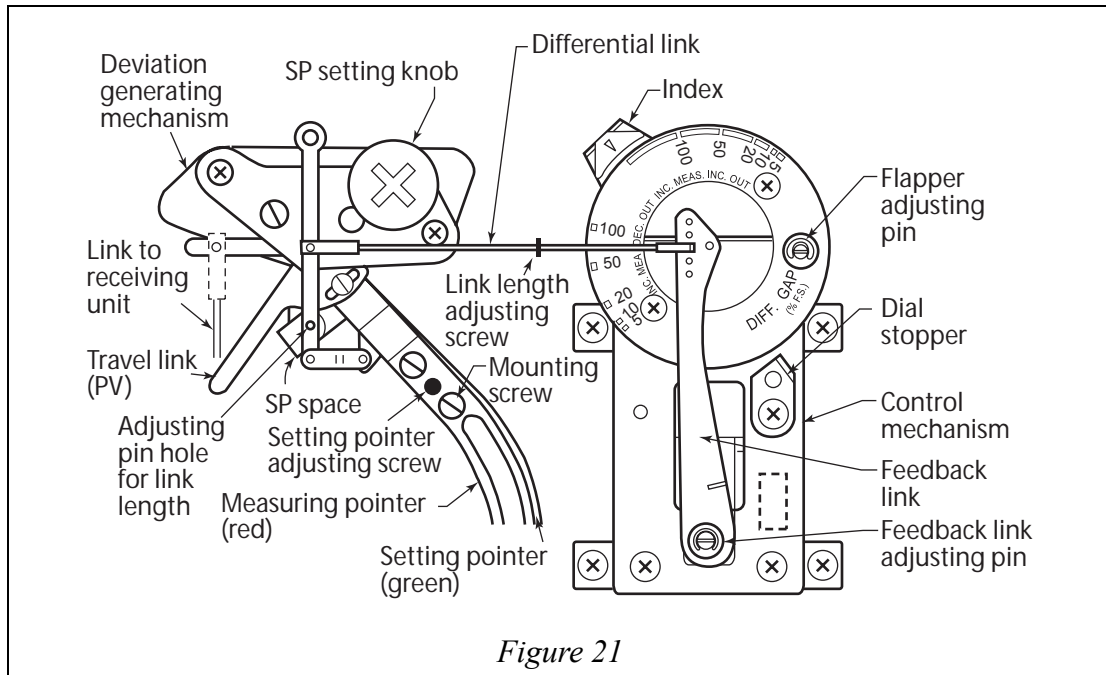

Figure 21

- (1) Either by disconnecting the link from the receiving unit or by setting measuring input for about 50%, make the measuring pointer indicate approximately 50% point on the scale.
- (2) Set the set point pointer at approximately 50% scale position with the setting knob in the case of the local type or with an external set point signal in the case of the cascade type.
- (3) Insert the adjusting pin through the adjusting pin hole.
- (4) If there is a gap difference between the ends of the set point pointer and the measuring pointer, eliminate the difference by turning the set point pointer adjusting screw.

If the motion is not smooth, temporarily loosen the clamping screw for adjustment. Then, tighten the screw firmly.

Connect a pressure gauge to the OUT connection port, and a supply air 140 kPa {1.4 kgf/cm²} to the SUP connection port.

5-2: Controller mechanism

5-2-1: Balance adjustment for controller proportional band

First, remove the dial stopper by loosening its screw.

- (1) Set the proportional band at 500%.
- (2) Set the set point pointer and the measuring pointer at 50%
- (3) With the reset dial set in the full open state (minimum reset time), set the output air pressure at 50% F.S. (59.1 kPa {443 mmHg}) by adjusting the set point pointer.
- (4) When the output pressure is stabilized, fully close (maximum reset time) the reset dial and move booth pointer to the 50% position.
- (5) So adjust the length of the deviation link that the difference of output pressures between when the proportional band dial is set at 20% (INC. MEAS. INC. OUT) and at 20% (INC. MEAS. DEC. OUT) is not greater than 0.8 kPa {6 mmHg}.
- (6) Adjust the flapper adjusting pin so that the change in the output pressure becomes less than 0.8 kPa {6 mmHg} when the proportional band is changed from 20% to 500%. (Turn the adjusting pin clockwise if the output increases when the band is changed from 20% to 500%.)
- (7) Adjust the feedback link adjusting pin so that the output pressure becomes 59.1 ± 0.3 kPa { 443 ± 2 mmHg} at 500% proportional band. (The pressure increases as the pin is turned clockwise.)
- (8) Repeat step (5), (6) and (7) so that, in the entire range of the proportional band, the output pressure becomes 59.1 ± 1.2 kPa { 443 ± 9 mmHg} in the range of white figures 50 to 500 to yellow figure 50; and 59.1 ± 2.4 kPa { 443 ± 18 mmHg} in the other range.

- ~Note** 1: *With step (4), pneumatic pressure of about 59.1 kPa {443 mmHg} is sealed in the controller reset chamber. Since the pressure may change in a prolonged time, complete the above operations as rapidly as possible.*
- 2: *For change between INC. MEAS. INC. OUT (direct action) and INC. MEAS. DEC. OUT (reverse action), free the dial stopper by loosening its clamping screw, turn the dial to the opposite action range, and then fix the dial stopper.*

5-2-2: Calibration of reset and rate units

Be extremely careful when handling the reset (rate) restriction. Even a minor damage to the needle or valve seat can cause a great change in the characteristics. So, the reset restriction and the dial base are firmly fixed. When the unit has been disassembled for servicing, calibrate it observing the following procedures:

Reset unit

- (1) Set the set point pointer (SP) at 50% F.S.
- (2) Set the proportional band dial at 100 (% P.B.) of direct action. In this case, fully open (0.05 min. or less) the reset restriction and, if the rate unit is provided, fully open (0.05 min. or less) the rate restriction also.
- (3) By adjusting the PV value, balance the controller output (control output pressure) at 46.7 kPa {350 mmHg}.
- (4) Fully close the reset restriction (30 min. or more).
- (5) By adjusting the PV value, set the controller output at 53.3 kPa {400 mmHg}.
- (6) See the reset dial at 2 min.
- (7) Measure the time required by the controller output to change from 53.3 to 60 kPa {400 to 450 mmHg}.
- (8) Make sure that the measured time is not longer than 120 ± 60 sec.
- (9) Adjust the position of the reset unit dial after loosening its two set-screws, as required.

Rate unit

- (1) Set the set point pointer (SP) at 50% F.S.
- (2) Set the proportional band dial scale at 100 (% P.B.) of direct action. In this case, fully open (0.05 min. or less) the rate restriction and, if the reset unit is provided, fully open (0.05 min. or less) the reset restriction also.
- (3) By adjusting the PV value, set the controller output at 40 kPa {300 mmHg}.
- (4) Fully close the reset and rate dials (30 min. or more).
- (5) By adjusting the PV value, set the controller output at 80 kPa {600 mmHg}. (Denote this value by n_1 .)
- (6) Fully open the rate dial (0.05 mm or less), measure the residual pressure (denote this value by n_2) and calculate the rate amplitude.

$$\text{Rate amplitude } W = \left(\frac{n_1}{n_2} \right)$$

- (7) Repeating the procedure of (2) to (5) so that the controller output becomes 80 kPa {600 mmHg}.
- (8) Rapidly change the rate dial to 2 min. and measure the time t in which the output change to 63.2% of the value of $n_1 - n_2$.
- (9) Make sure that $t \times W$ is not longer than 120 ± 60 sec.

(10) If necessary, adjust the position of the rate unit index.

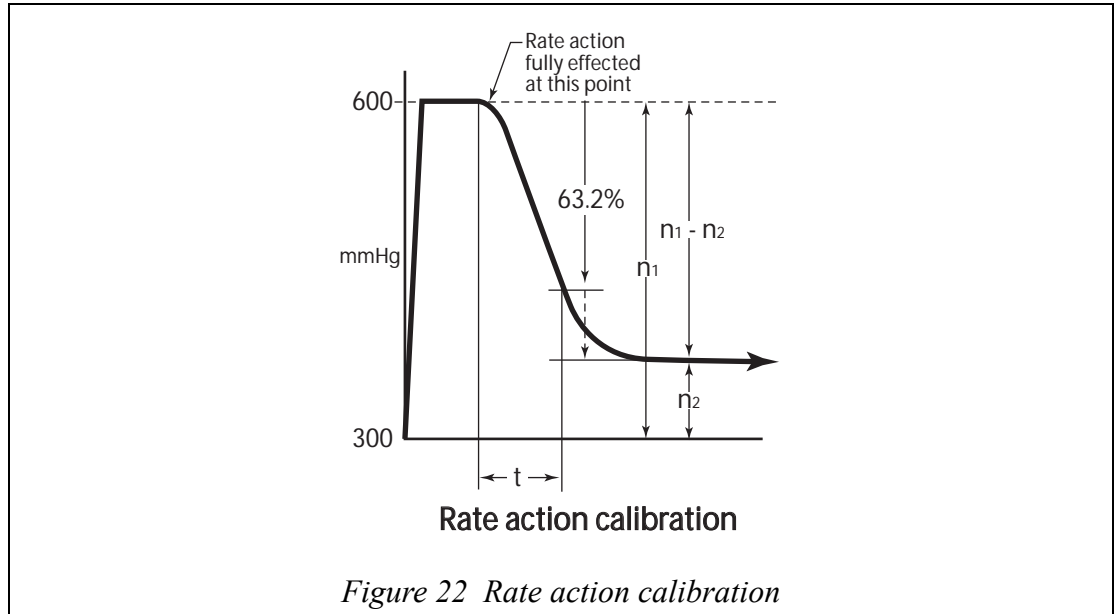

5-2-3: Other calibration and adjustment procedures

On-Off controller

Before adjustment, perform the following confirmation procedure (confirmation of zero deviation):

- (a) Set the set point pointer at 50%.
- (b) Disconnect the travel link (PV) from the indicating mechanism, and insert the adjusting pin.
- (c) Make sure that there is no deviation between the PV pointer and the SP pointer. If there is any deviation, eliminate it by using the set point pointer adjusting pin.
- (d) Remove the adjusting pin and connect the travel link (PV).

Adjustment

- (1) Turn fully counterclockwise the set point dial and set it to the white edge line of the INC. MEAS. INC. OUT scale. Apply a deviation that will make the output 59.1 ± 0.8 kPa { 443 ± 6 mmHg}. Read the deviation by the pointer on the scale.
- (2) Turn fully clockwise the set point dial and set it to the yellow edge line of the INC. MEAS. DEC. OUT scale. Then perform a procedure the same as step (1).

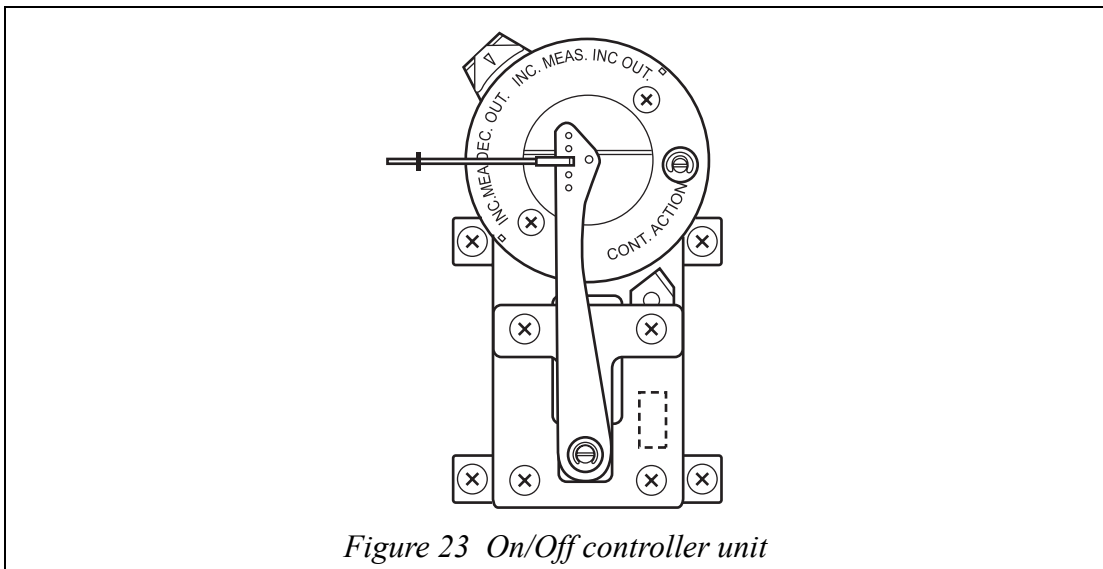

- (3) Adjust the deviation link length so that the deviation values read in steps (1) and (2) are the same in the value but the reverse in the direction. The link becomes shorter when the deviation link adjusting screw is turned upward.
When the deviation values in steps (1) and (2) are of the same direction, if the red pointer shows a higher value than the green pointer, make the link longer. If the green pointer shows a higher value, make the link shorter.
- (4) Make the deviation zero, and set the set point dial to the white line. Under this state, adjust the flapper adjusting screw so that the output is somewhere within a range of 10 to 130 kPa {0.1 to 1.3 kgf/cm²}.
- (5) Set the set point dial to the yellow line, and adjust the deviation link length so that the output is somewhere within a range of 10 to 130 kPa {0.1 to 1.3 kgf/cm²}.

- (6) Repeat steps of (4) and (5) so that in each of the cases in which the set point dial is set to the white and the yellow line, the output will be somewhere within the range of 10 to 130 kPa {0.1 to 1.3 kgf/cm²}.

Differential gap controller

Before adjustment, perform the following confirmation procedure (confirmation of zero deviation):

- (a) Set the set point pointer at 50%
- (b) Disconnect the travel link (PV) from the indicating mechanism and insert the adjusting pin.
- (c) Make sure that there is no deviation between the PV pointer and the SP pointer. If there is any deviation, eliminate it by using the set point pointer adjusting pin.
- (d) Remove the adjusting pin and connect the travel link (PV).

Adjustment

- (1) Make initial setting of the flapper adjusting pin and feedback link adjusting pin as follows:
 - (a) The flapper adjusting pin rotates 360°. Make the pin slot horizontal at the side where the flapper rises when the adjusting pin is turned clockwise.
 - (b) The feedback link adjusting pin also rotates 360°. Make the pin slot horizontal at the side where the link falls when the adjusting pin is turned clockwise.
- (2) Set the set point pointer at 50%.

Set the differential gap setting dial at the minimum point (0%) on the INC. MEAS. INC. OUT side. Moving the PV pointer, note the points where the output starts rising and falling and determine the difference between these two points.

- (3) Set the dial at the minimum point on the INC. MEAS. DEC. OUT side. Moving the PV pointer, check the points where the output starts rising and falling.
- (4) Adjust the deviation link so that the output the rising points of steps (2) and (3) are distribute as equal as possible with the set point as the center of distribution.

If the distribution point is on the plus side, make the link longer. If the distribution point is on the minus side, make the link shorter.

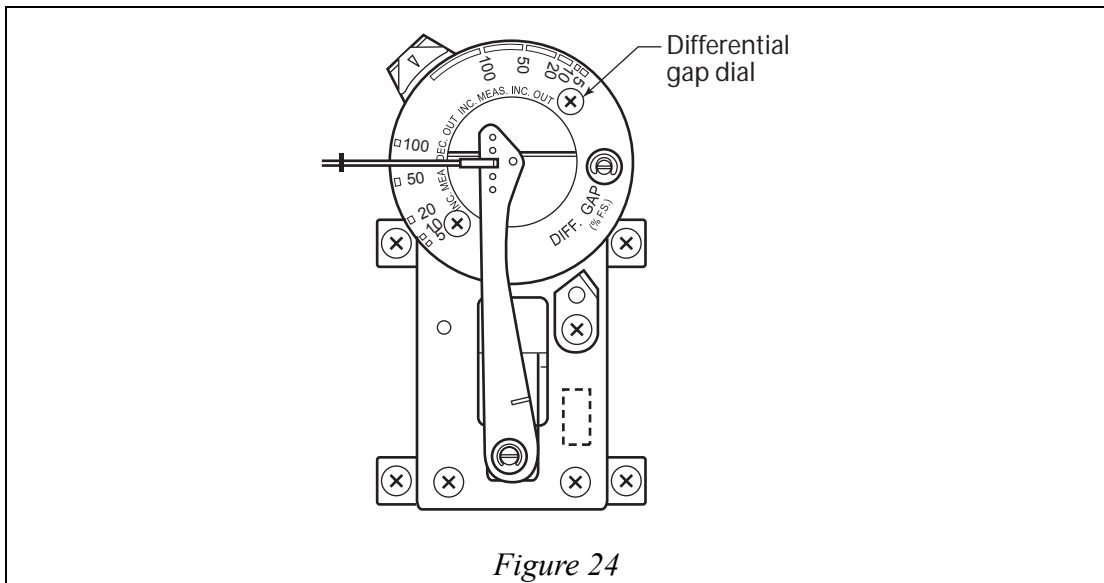

Figure 24

- (5) With the flapper adjusting pin, the output rising points recorded in steps (2) and (3) with the set point.

Repeat actions in steps (4) and (5) until both rising points conforms with the set point.

- (6) Set the differential gap dial to the 100% position on the right or left side.

Adjust the feedback link adjusting pin so that the output rises at the setting point. (to lower the output for once, slightly open the flapper with the tip of a screw driver.)

- (7) Repeat steps (4), (5) and (6) so that the output rising points falls within the gap of set point (SP) $\pm 1.5\%$ F.S. at entire range of the differential gap dial.

5-3: Adjustment of set point indication

Calibrate the set point indication by connecting an input (20 to 100 kPa {0.2 to 1.0 kgf/cm²} pressure) to the ESP connection port of the instrument.

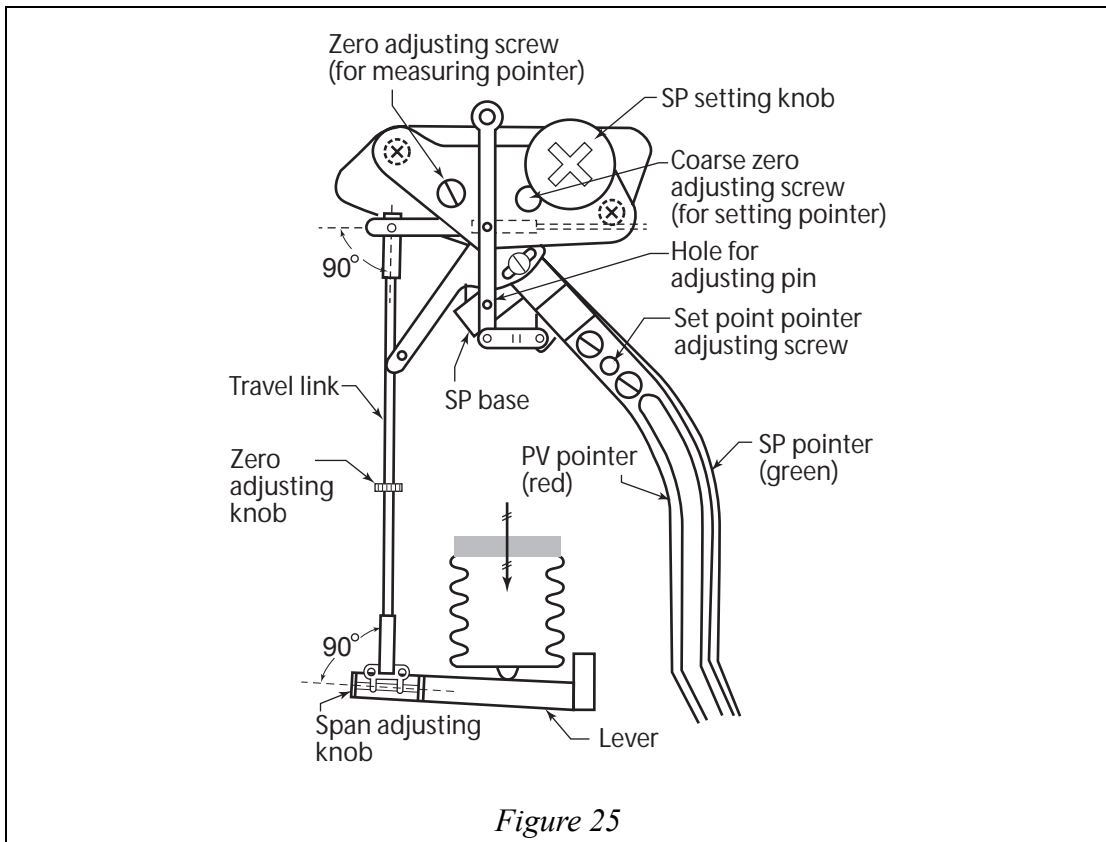

(1) Zero adjustment

Turn the zero adjusting knob of the travel link so that when the input is 0%, the measuring pointer points at 0. The pointer falls as the knob is turned clockwise as viewed from the bottom of the instrument.

(2) Span adjustment

Turn the span adjusting screw so that when 80% input is applied, the PV pointer indicates 80%. As the screw is turned clockwise, the span increases.

If a large change in the span is necessary, change the position of connection of the travel link and the hole of the span adjusting screw. As the connection position is set farther from the center of the element, the span becomes larger.

(3) Linearity adjustment

(a) Check the linearity at the 50% scale point.

(b) If an error larger than 1% F.S. is detected, change the travel link length by turning the adjusting knob. If the error is plus with respect to the scale, make the travel link shorter (turn counterclockwise as viewed from the bottom).

(c) A change in the travel link length will cause a shift of zero point. So, loosen the zero adjusting screw, align the pointer to the scale and then fasten the screw.

(d) Check again the zero and span in the method mentioned before.

5-4: Transmitter unit

The transmitter unit is of a balanced displacement type. When adjusting this unit, check at first that the measuring arm and lever are at the right angle with respect to the travel link. If they are not set the right angle as visually inspected, perform calibration and adjustment of the deviation generating mechanism.

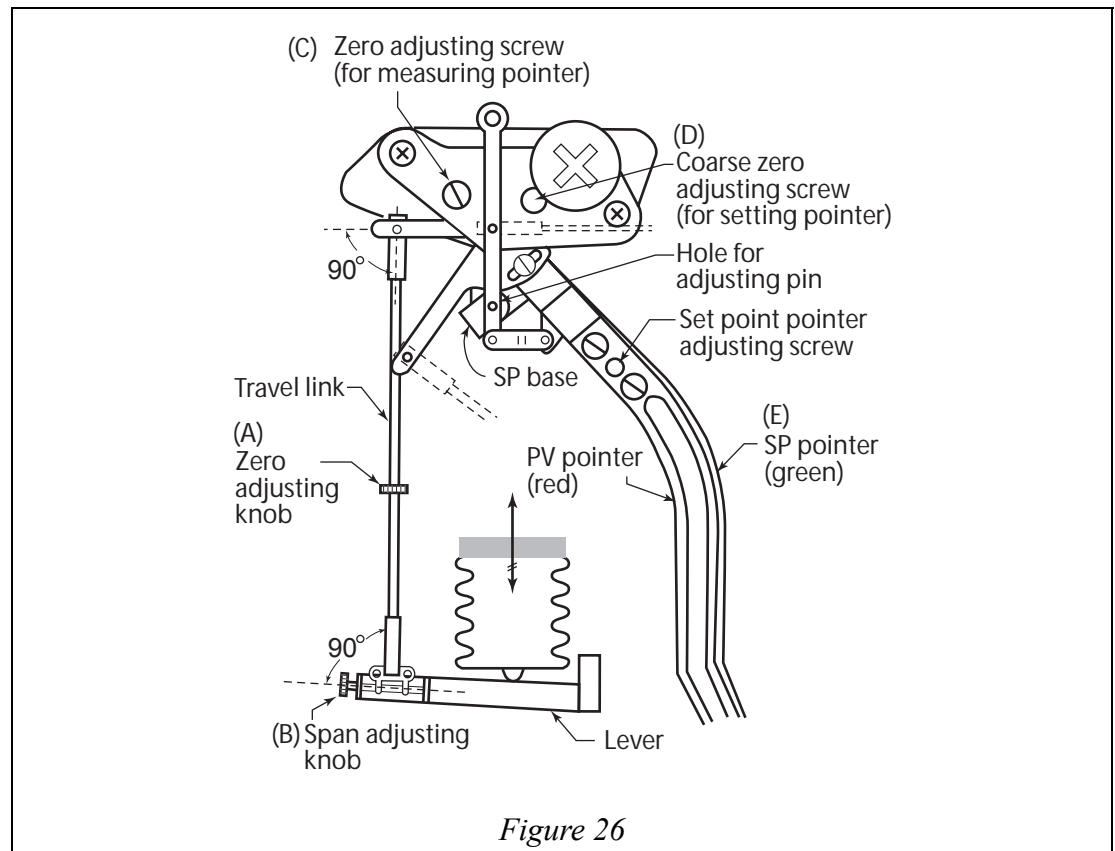

Adjustment of zero and span

- (a) Set the PV pointer at 0% and turn the zero (linearity) adjusting knob (A) so as to make the transmitted pressure 19.7 kPa {148 mmHg}. The transmitted pressure increases as this knob is turned clockwise as viewed from the case bottom.
- (b) Set the PV pointer at 100%, and turn the span adjusting knob (B) so that the transmitted pressure becomes 98.4 kPa {738 mmHg}. The span is decreased as this knob is turned clockwise as viewed from the left side.
- (c) Repeat the above procedures so that both zero point and span are correctly set.

Adjustment of linearity

- (a) After adjusting the zero and the span, set the PV pointer at 50% and check that the transmitted output is 59.1 ± 0.8 kPa { 433 ± 6 mmHg}.
- (b) If the output is less than 58.3 kPa {437 mmHg}, turn the zero (linearity) adjusting knob (A) counterclockwise so that the transmitted output increases.
- (c) If it is more than 59.9 kPa {449 mmHg}, turn the knob (A) clockwise. In this case, about 10% F.S. movement of the zero point is needed per about 1% F.S. deviation between the PV pointer and the transmitted pressure.

- (d) Readjustment for the zero point shift caused as above. If the shift is large, adjust with the coarse adjusting screw (C), and achieve fine adjustment with the zero (linearity) adjusting knob (A). Connect a suitable pressure measuring instrument to the “X” connector on the bottom of case where the transmitted pressure is delivered from.

5-5: Detecting element

Before starting calibrating the detecting element, make it sure that the deviation generating mechanism has been correctly adjusted.

Set the proportional band at 100%, the reset at full open (minimum integration time), the rate at full open (minimum derivative time) and both the PV pointer and the SP index at 50%, move the SP index so as to make the output air pressure 50% F.S. (59.1 kPa {443 mmHg}), and set the reset at full close (maximum integration time).

5-5-1: Pressure element

Zero adjustment

Turn the adjusting knob on the travel link so that the PV pointer indicates 0% when the element input is set at 0%.

Span adjustment

Turn the span adjusting screw so that the PV pointer indicates 80% scale when 80% input is applied to the element. The span increases as the screw is turned clockwise.

If large change is required for the span, change the connecting position between the travel link and the span adjustment screw hole. As the connecting position is set farther from the center of the element, the span increases.

Linearity adjustment

- (1) Check the linearity at 50% of the scale.
- (2) If error more than 1% F.S. is observed adjust the travel link length by turning the adjusting knob (F). If the error is on plus side with respect to the scale, shorten the travel link (turn it counterclockwise as viewed from the element).
- (3) The zero point will be shifted when the travel link length is changed. Re-align the pointer to the zero scale position by loosening the zero adjusting screw.

(4) Recheck the zero and the span in the method mentioned above.

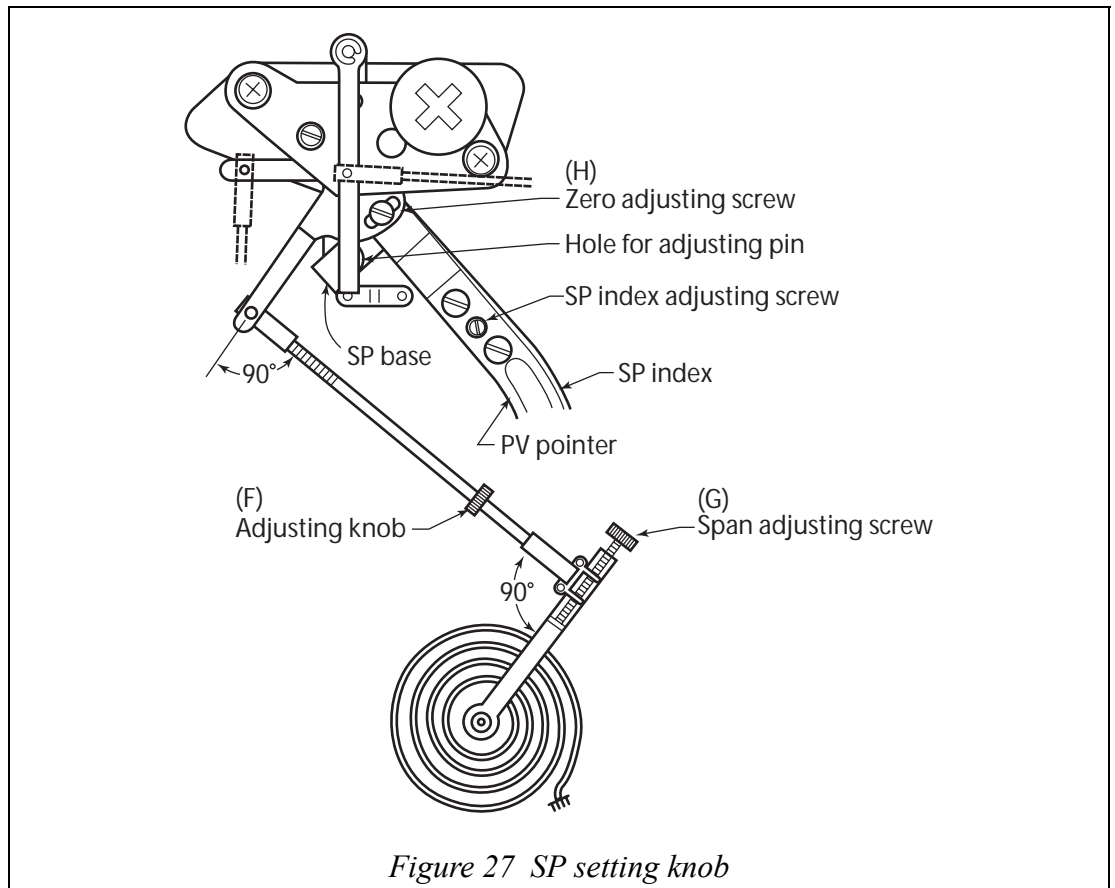

Figure 27 SP setting knob

5-5-2: Temperature element

The calibrating and adjusting procedure for the temperature are the same as for the pressure element. Use accurate calibrating devices.

- (a) Check accuracy of the constant temperature bath to ensure that it indicates accurately 0, 50, and 100% F.S. of the temperature range.
- (b) An accuracy of $\pm 1\%$ F.S. or better is required for the constant temperature bath as calibrated with a standard thermometer.
- (c) Before starting calibration, completely immerse heat sensing section of the element and wait until the pointer is stabilized. Note that a longer time will be required for an element with protecting tube or a high-temperature element (400°C or 500°C type with sealed gas).

6: Maintenance and troubleshooting

6-1: Routine inspection

- (1) Check for any air leakage from the air piping and the connecting joints.
- (2) Also check the air supply drain, the filter and compressor, the air cleaning and dehumidifying equipment and the tank.
- (3) Check for any clogging of the filter and the restriction inside the instrument. Replace the clogged filter. If the restriction is clogged, clean it with a 0.12 mm wire.

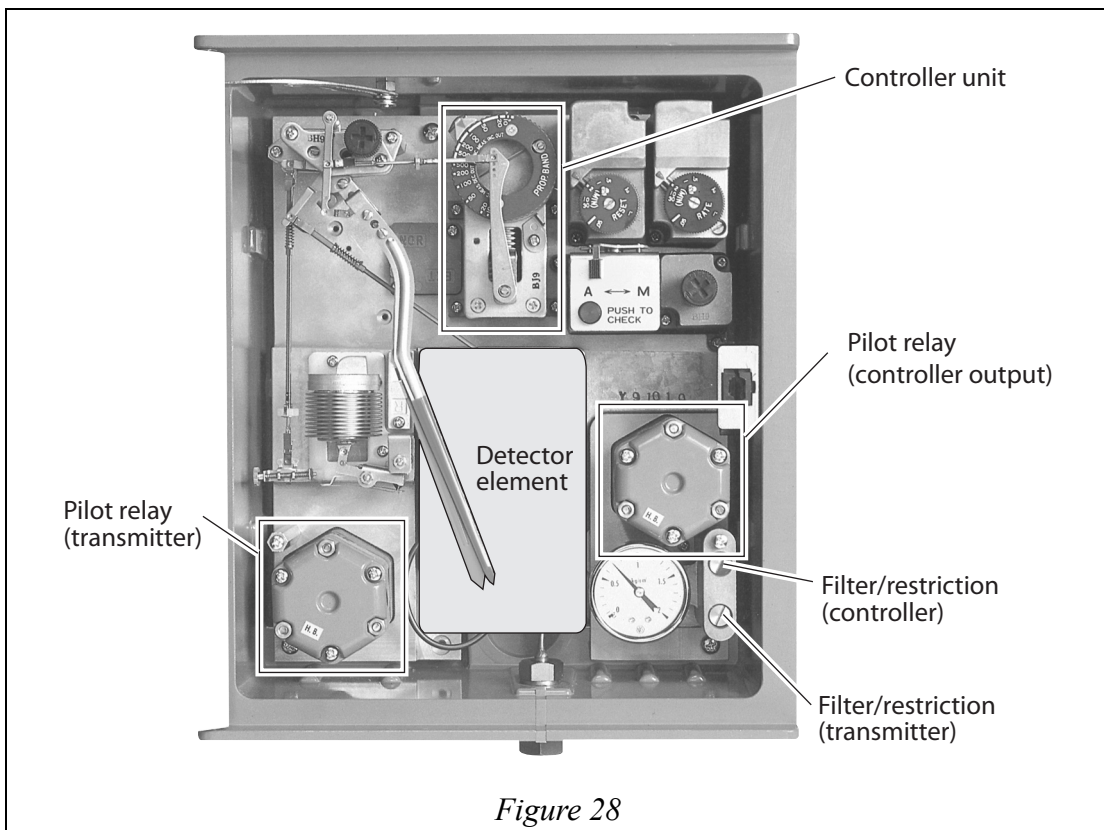
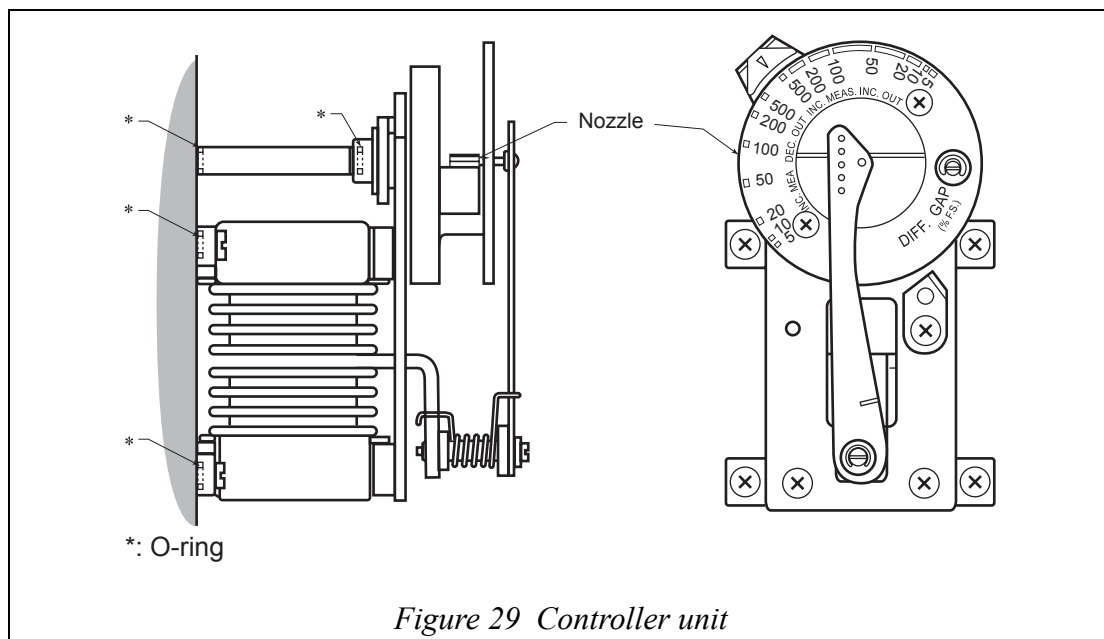

Figure 28

6-2: Controller unit

- (1) Shut off the supply air pressure, and remove the differential link.
- (2) Loosen the four clamping-screws of the controller unit, take out the controller unit and clean the nozzle.
- (3) For assembly, follow the disassembly procedure in the reverse order. Re-adjust the control unit after re-assembly.

Confirm that the O-rings are placed. Securely tighten the unit with the four screws and check that there is no air leakage.



6-3: Pilot relay

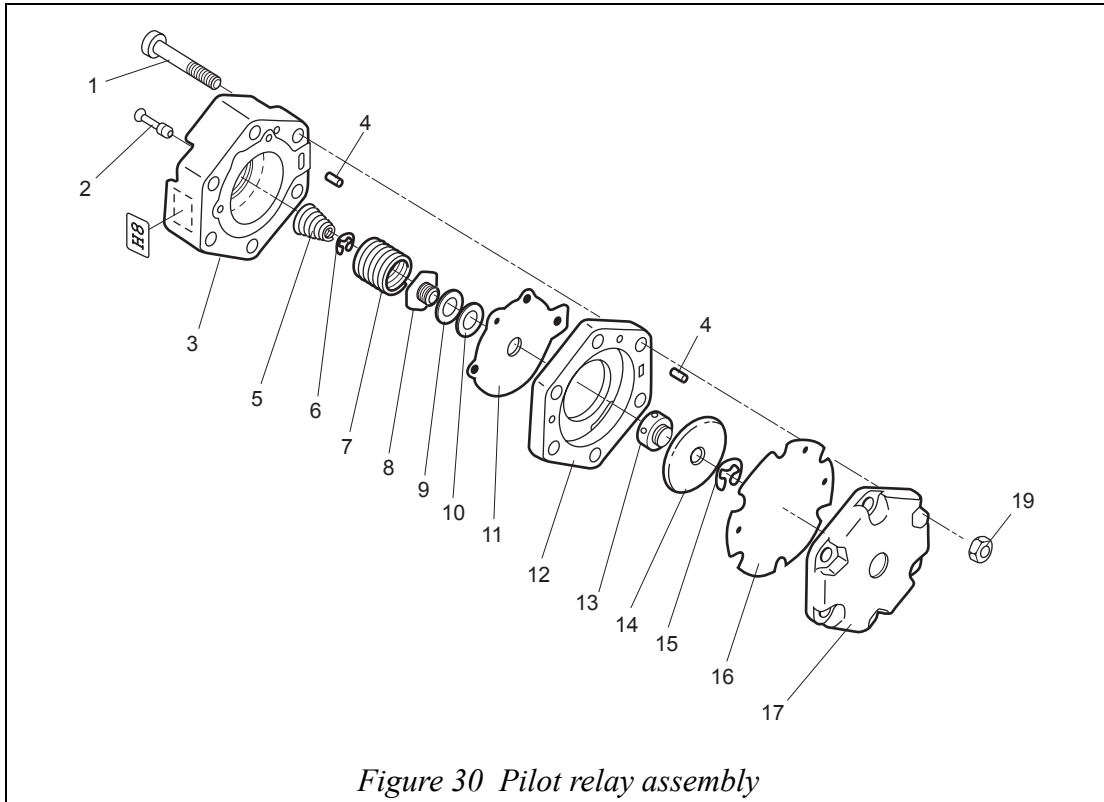

No.	parts name	Qty.	No.	parts name	Qty.
1	Mounting screw	3	10	Seal	1
2	Valve stem	1	11	Diaphragm (lower)	1
3	Housing	1	12	Exhaust ring (out)	1
4	Guide pin	6	13	Exhaust ring (in)	1
5	Conical spring	1	14	Area plate	1
6	Pin washer	1	15	Pin washer	1
7	Spring	1	16	Diaphragm (upper)	1
8	Nozzle	1	17	Cover	1
9	Washer	1	19	Nut	3

- (1) To remove the pilot relay from the manifold, remove three fastening screws, lock washers and the gasket attached to the manifold.
- (2) Servicing the pilot relay
 - (a) Remove three fastening screw (1) and nuts (19).
 - (b) Remove parts (3) to (17) in the due order. Unless replacement is required, do not remove parts (2) to (6)
 - (c) Clean metallic parts with an appropriate solvent such as petroleum naphtha or chlorosene. Do not apply any solvent to the diaphragms. To let the solvent to pregnate through the sheet surface, push valve system (2) in the direction of compressing conical spring (5).

- (d) Check for any stain on inner exhaust ring (13). If it stained, clean it with a cloth moistened with solvent.
 - (e) Fully dry all parts with clean compressed air.
 - (f) Replace if diaphragms (16) and (11) are worn or damaged.
 - (g) For reassembly of the pilot relay, assemble all parts in the correct order and fasten them with screws (1) and nuts (19). Tighten all screws to uniform tightness.
- (3) Mounting the pilot relay
- (a) Place the gasket at the mounting position of the pilot relay.
 - (b) Mount the pilot relay to the manifold with the clamping screws and the spring washers. Tighten all screws to uniform tightness.

6-4: Removing the AUTO unit when in manual operation

- (1) Balance the A/M output pressure and transfer operation to the M mode.
- (2) Apply a deviation in the direction that the AUTO output pressure decreases. (Turn the SP knob so that SP becomes smaller than PV when in the direct action.)
- (3) Set the controller proportional band at the minimum ($PB \leq 5\%$).
- (4) Press the CHECK button of the manual controller unit and check that the AUTO unit output pressure is zero.
- (5) Remove the AUTO units (controller unit, rate unit and reset unit).
In this case the manual output pressure will slightly fall re-adjust the manual output pressure as required.
- (6) In the case that SP is set in the remote setting mode (cascade type) and cannot be varied, proceed as follows instead of performing the procedure of steps (2) and (3).
 - (a) Disconnect the link of the element and make zero the AUTO output pressure by moving the PV pointer.
 - (b) Move the flapper away from the controller so that the nozzle back pressure becomes zero.

6-5: Troubleshooting

For troubleshooting the instrument, see the following table. For adjustment, refer to the preceding chapter.

Symptom	Probable cause	Troubleshooting
Pilot relay whines.	Valve sheet is stained.	Remove pilot relay, and clean valve sheet.
Little or no control pressure is delivered.	Supply air pressure is off or below 140 kPa {1.4 kgf/cm ² }. Restriction is clogged.	Provide proper supply pneumatic pressure. Remove restriction and clean it.
	Restriction is not correctly set.	When no transmitter is used, restriction is provided with blind plug. Reattach it to correct position. Correctly set restriction(s) and plug depending on whether the instrument has transmitter or not.
	Filter is badly stained.	Replace filter
	There is leakage in nozzle circuit of indicating control section.	After making sure that O-rings are properly attached, firmly tighten the controller unit and restriction.
	There is leakage or choking in A/M transfer circuit. (When A/M transfer switch is provided.)	Remove manual control unit and make sure that circuit is correct and that O-rings of connecting section are properly attached. Then, firmly tighten the unit.
	There is leakage from pilot relay diaphragm.	Remove pilot relay, check diaphragm and, in case of leakage, replace diaphragm.
Control pneumatic pressure is too high	Nozzle of indicating control section is clogged.	Clean nozzle.
	Restriction screw of indicating control section is not in firm contact with sheet surface.	Tighten so that sheet surface of restriction screw is contacted with the manifold.
	Valve sheet of pilot relay is stained.	Remove pilot relay and clean valve sheet.
Input offset in indication is large.	Set point pointer or measuring pointer is shifted.	Readjust deviation generating mechanism and indicating mechanism. (See “5: Calibration and adjustment”.)
	Control mechanism is not properly adjusted. (Proportional band is not properly balanced.)	Adjust the balancing of control mechanism. (See “5: Calibration and adjustment”)
Reset rate is abnormal or ineffective.	Needle or sheet is damaged.	Use new needle assembly.
	Dial attaching screw is loose.	Set dial in correct position and fix it firmly with screw.
	Air is leaking from gasket.	Firmly fix it to the base.
Manual control pressure does not rise.	Supply pneumatic pressure is not applied or below 140 kPa {1.4 kgf/cm ² }.	Supply proper supply air pressure.

Yamatake Corporation

Symptom	Probable cause	Troubleshooting
Manual control pressure does not fall	Valve stem of manual regulator has collected dirt or dust.	Disassembly and clean manual regulator.
Zero point change unreasonably when range is changed.	Parallelism adjustment of transmitter beam is poor.	Perform parallelism adjustment and calibration.
Output is unstable or pulsates.	Air is leaking.	Tighten pneumatic piping and gaskets.
	Assembly of nozzle flapper is improper.	Reassemble the nozzle.
	Pilot relay is stained.	Remove and clean pilot relay. If necessary replace it.

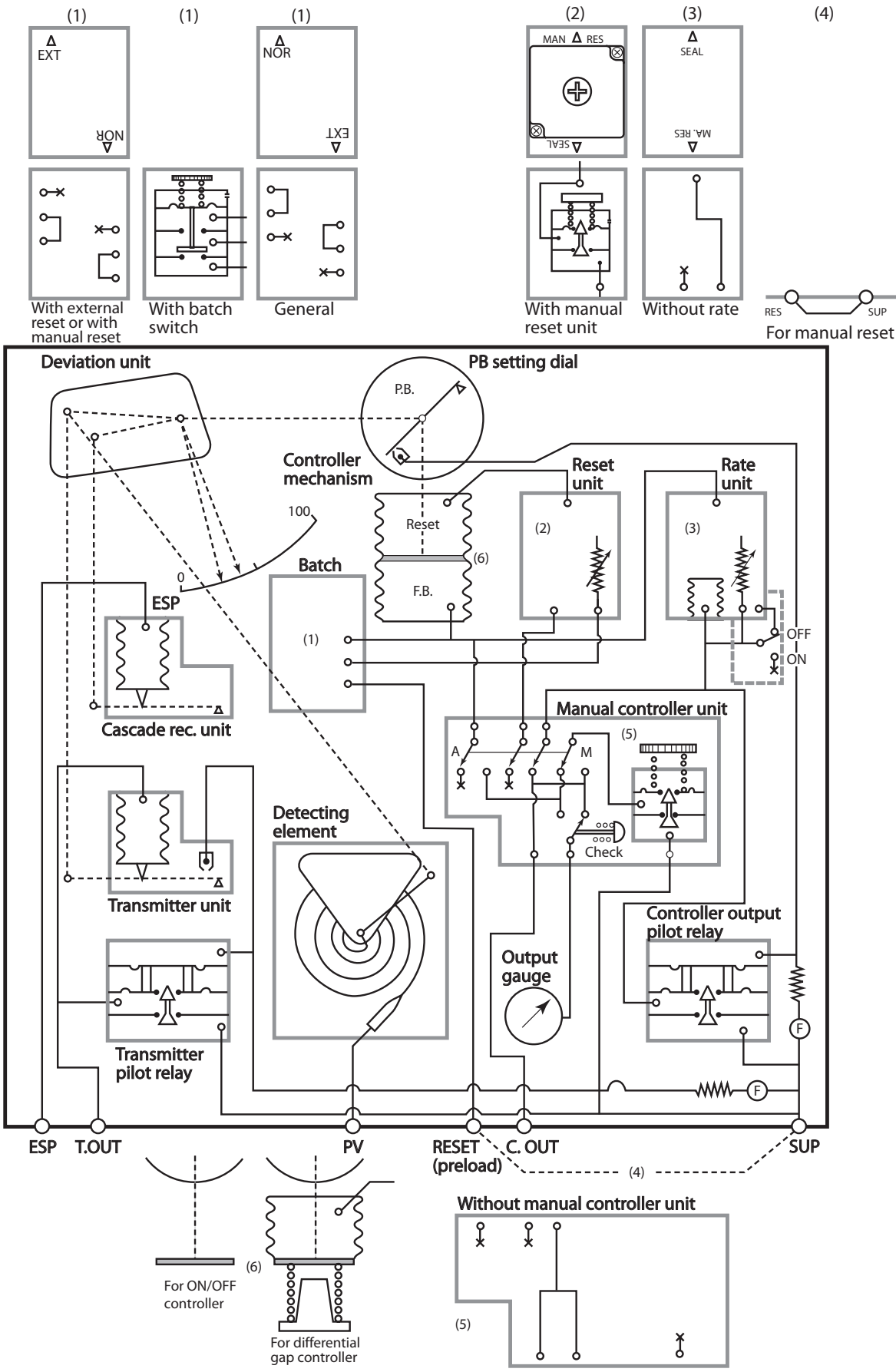

Figure 31 Circuit diaphragm

Document Number:	OM2-6110-0100
Document Name:	KF series (Field mount type) pressure (temperature) indicating controller Model: KFP/KFT User's Manual
Date:	Mar. 2005 (Rev.12)
Issued/Edited by:	Yamatake Corporation

Yamatake Corporation

Totate international Building
2-12-19 Shibuya
Shibuya-ku, Tokyo 150-8316
Japan

Tel : 81-3-3486-2310

Fax : 81-3-3486-2593

YAMATAKE
Savemation

Saving through Automation