

DIMENSION DRAWING

UNIT : mm

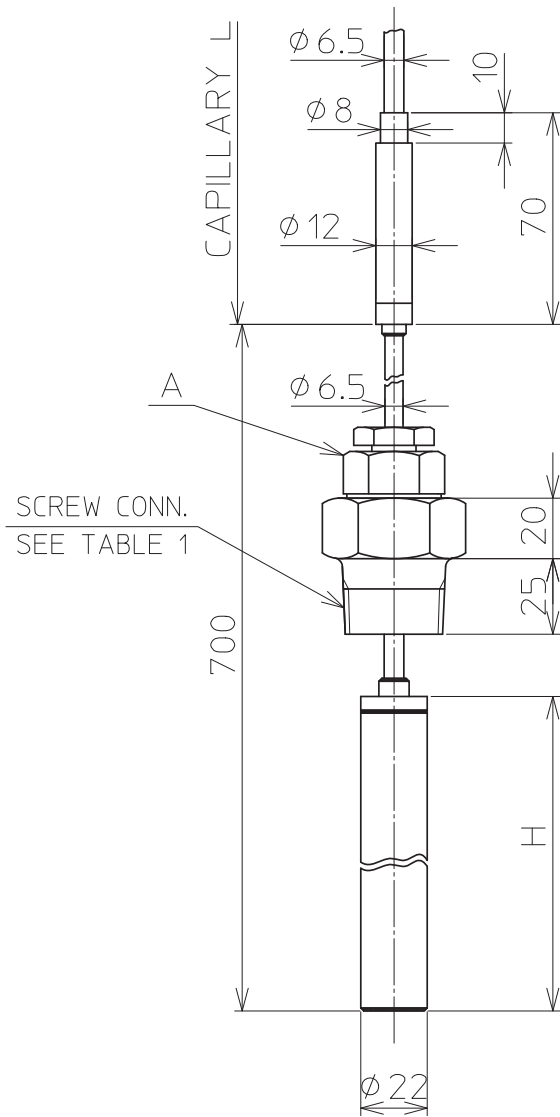

DETAILS OF "A"

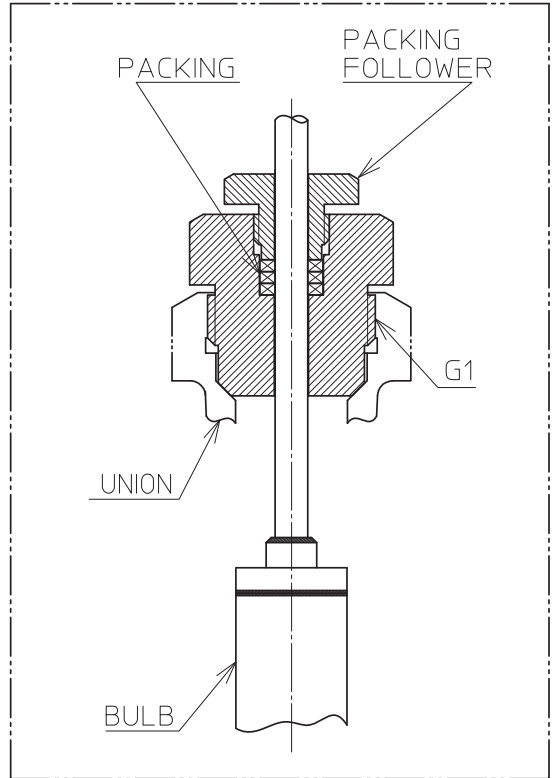

TABLE 1
SCREW CONNECTION

UNION SCREW SIZE	
R1 MALE	※1
1NPT MALE	※2

TABLE 2
BULB DIMENSIONS

MEASURING RANGE	H	GAS FOR SENSOR
0 ~ 400℃	260	NITROGEN
0 ~ 500℃	260	
100 ~ 400℃	260	↓

SPECIFICATIONS

CAPILLARY LENGTH
 STANDARD L=5m
 SEMI-STANDARD (Y160) L=10m
 SENSING ELEMENT MATERIAL
 CAPILLARY : SUS304
 BULB : SUS304

- ※1 : WHEN THE INSTRUMENT MODEL INCLUDES A SELECTION A TO SPECIFY THE AIR PIPING CONNECTION.
- ※2 : WHEN THE INSTRUMENT MODEL INCLUDES A SELECTION B TO SPECIFY THE AIR PIPING CONNECTION.
- ※3 TO BE MANUFACTURED AS SPECIFIED.

0	04	11	15	kodama/fujimoto	3	.	.	.
1	10	11	30	kodama	4	.	.	.
2					5	.	.	.

KF SERIES
 SENSING ELEMENT (GAS-FILL TYPE · WITH UNION)

MODEL NO.
 KFT(A)····-07····-U

Azbil Corporation

DATE 04.6.10
 REF. 82737206

DRAWING NO.
 ED-611011-18