

**ST3000 ACE
Smart Multivariable Transmitter
Model: JTD720A**

User's Manual



Yamatake Corporation

Copyright, Notices and Trademarks

Printed in Japan - © 2004 by Yamatake Corporation ALL RIGHTS RESERVED

While this information is presented in good faith and believed to be accurate, Yamatake Corporation disclaims the implied warranties of merchantability and fitness for a particular purpose and makes no express warranties except as may be stated in its written agreement with and for its customer.

In no event shall Yamatake Corporation be liable to anyone for any indirect, special or consequential damages. This information and specifications in this document are subject to change without notice.

Safety

Safety instructions

Preface

Correct installation and periodic maintenance are essential to the safe use of your differential pressure transmitters.

Read the safety instructions provided in this manual carefully and understand them fully before starting installation, operation, and maintenance work.

Inspection

On delivery, make sure that the specifications are correct and check for any damage that may have occurred during transportation. This equipment was tested under a strict quality control program before shipment. If you find any problem in the quality specifications, please contact your Yamatake Corporation representative immediately, providing the model name and serial number.

The name plate is mounted on the top of the enclosure.

Precautions

The following symbols are used in this manual to ensure user safety.

WARNING

Denotes a potentially hazardous situation which, if not avoided, could result in death or serious injury.

CAUTION

Denotes a potentially hazardous situation which, if not avoided, could result in operator minor injury or damage to device.

Safety messages

Installation

WARNING

- When installing the transmitter, ensure that the transmitters gaskets do not protrude from the process connection parts, such as flanges contacting the process pipes.
- Never use the transmitter in applications that are outside the rated pressure or temperature range. Always observe connection specifications. Damage to the transmitter, or leakage, may endanger plant, equipment or human safety.
- In areas designated as explosion-proof, apply to any cabling work the methods specified in the explosion-proofing guidelines.

CAUTION

- After installation, do not step on the transmitter as this may damage it, or cause physical injury.
- The glass indicator may break if hit with a tool or other object, and cause physical injury.
- Install the transmitter correctly. Incorrect installation may lead to output errors or violate applicable regulations.
- This transmitter is heavy. During installation, please ensure that your footing is safe, and always wear safety shoes.

Electrical wiring

WARNING

To avoid electric shocks, dry hands completely before performing wiring work and turning the power OFF. Wear gloves over dry hands.

CAUTION

- Before startup, study the specifications carefully and ensure that the wiring is correct. Wiring errors may cause hardware damage or other malfunctions.
- Provide a power supply that matches the specifications of the transmitter. Incorrect power supply may cause hardware damage.

Maintenance

WARNING

- Before disconnecting the transmitter from the process for any reason including maintenance, wait for safe levels in residual pressure, fluid or gas. Extreme caution should be taken to avoid fluid eruption.
- Prevent burns. Check venting or draining direction, and keep plant personnel out of the way of vented gas or drained fluid.
- When operational, never open the cover in an explosion-proof area. Avoid explosions or other combustion accidents.

CAUTION

Strict product controls were exercised during the manufacture of this transmitter. Never modify the transmitter in any way. In-plant modifications may result in damage to the transmitter or to property and human safety.

Communication equipment

CAUTION

Avoid use of communication equipment near this transmitter. Interference from such equipment as a transceiver, a cellular phone, a PHS, a beeper may result in malfunction (at some transmission frequencies). In any case, observe the following precautions:

Check in advance of using any such equipment, the clearance required to ensure safe operation of the transmitter. When using communications equipment, always maintain a distance at least equal to this distance, between the communication equipment and the transmitter.

Close transmitter cover before using communication equipment.

Unpacking, Checking, and Storage

Unpacking the transmitter

This transmitter is precision equipment. Handle it carefully to prevent an accident and damage.

Checking accessories

In the package you receive from Yamatake or our representative, is included the main unit of a transmitter and the following accessories:

- One 3-inch, L-shaped wrench

Checking specifications

The specifications are marked on the transmitter nameplate. The specifications on this nameplate should agree exactly with your order. Especially, check the following:

- Tag No. (TAG No.)
- Model No. (MODEL)
- Production No. (PROD No.)
- Low and high limits of set range (RANGE)
- Supply voltage (SUPPLY)
- Explosion-proofing conformance (mark is applicable only to explosion-proof model)

Inquiry

Direct any inquiries about this transmitter to our nearest branch office or representative.

When making an inquiry, have handy a copy of the details marked on the nameplate:

- Model No. (MODEL)
- Production No. (PROD No.)

Storage

Storage over long periods requires special procedures, to avoid damage to this instrument. Always store the transmitter:

- Indoors and at normal temperature and humidity.
- In a location subject to minimum vibrations and shocks.
- Before unpacking, not after.

Table of Contents

Chapter 1 : Functions, Configurations, and Structures of model JTD720A and SFC

1-1 : Digital indicator (optional).....	1-1
Main display	1-1
Sub display	1-1

Chapter 2 : Installation

2-1: Installation environment	2-1
2-1-1: General environmental conditions	2-1
Introduction.....	2-1
Environmental conditions	2-1
2-1-2: Environmental conditions for explosion-proof transmitter.....	2-2
Explosion-proof transmitter installation precautions	2-2
Environmental conditions for flameproof, special explosion-proof transmitter.....	2-2
Reference document	2-3
2-1-3: Installing the transmitter	2-4
Before you install the transmitter	2-4
2-1-4: Transmitter main unit installation position	2-5
2-2: Piping	2-7
2-2-1: Piping considerations	2-7
Introduction.....	2-7
3-way method valve (option)	2-7
Extension pipe (option).....	2-7
High-pressure marking	2-8
Pipe selection	2-8
Materials and requirement.....	2-8
Piping for liquid gas or steam flow rate measurement.....	2-9
2-3: Electrical wiring	2-12
Introduction.....	2-12
Wiring	2-12
Conduit pipe	2-12
Grounding.....	2-13
Supply power.....	2-13
Connecting SFC	2-14

Chapter 3 : Using the SFC to configure and operate your transmitter

3-1: General information and procedures for configuration.....	3-2
3-1-1: Items of configuration data	3-4
3-1-2: Outline of SFC display	3-8
3-1-3: How to enter configuration data.....	3-8

Table of Contents

Entering a tag number (establishing communications).....	3-10
Clearing the present display	3-11
To manually save configuration data into non-volatile memory (NVM).....	3-11
Selecting a damping time constant.....	3-12
Selecting an engineering unit of measure	3-12
Setting Lower Range Value LRV (Zero Adjustment).....	3-15
Setting Upper Range Value URV (Adjusting Span).....	3-17
Other settings	3-19
Setting for DE	3-32
3-2: Verifying the span	3-35
3-3: Verifying the maximum range	3-35
3-4: Verifying the input (Input Value of Each Sensor)	3-36
3-5: Verifying the output (Display of output in percentage)	3-37
3-6: To enter or clear OUTPUT mode	3-38
3-6-1: To enter OUTPUT mode	3-38
3-6-2: To clear OUTPUT mode.....	3-39
3-7: Verifying burnout direction	3-40
3-8: Verifying software version	3-40
3-9: Checking and correcting date and time (model SFC260 only)	3-40
3-10: Scratchpads (Memos).....	3-41
3-11: Printout of configuration data (model SFC260 only)	3-42
3-12: Print of SFC display (Action print) (model SFC260 only)	3-43
3-13: Feeding rolled paper (model SFC260 only)	3-43

Chapter 4 : Calibrating the Transmitter

4-1: Setting up transmitter for calibration	4-1
4-2: Operation modes and calibrated items	4-1
4-3: Calibrating output signal.....	4-3
4-3-1: Calibrating output signal at 0%.....	4-3
4-3-2: Calibrating output signal at 100%.....	4-4
4-3-3: Manually saving calibration data to Non-Volatile Memory (NVM)	4-5
4-3-4: Quitting constant-current source mode	4-5
4-4: Calibrating the differential pressure sensor.....	4-6
4-4-1: Calibrate zero point in equilibrium pressure state	4-6
Calibration in MEASUREMODE	4-6
Calibration in DP mode.....	4-7
4-4-2: Calibrating pressure range	4-10
Setting LRV	4-10
Setting URV.....	4-13
4-4-3: How to restore the initial calibration data.....	4-16
4-5: Calibrating the static pressure sensor.....	4-18
4-5-1: Calibration at atmospheric pressure.....	4-18

Table of Contents

Calibration in MEASURE mode.....	4-18
Calibration in the PP mode.....	4-19
4-5-2: Calibrating pressure range	4-21
Setting LRV	4-21
Setting URV.....	4-24
4-5-3: How to restore the initial calibration data.....	4-27
4-6: Calibrating the temperature sensor.....	4-30
4-6-1: Calibrating temperature range.....	4-30
Setting LRV	4-30
Setting URV.....	4-33
4-6-2: How to restore the initial calibration data.....	4-36

Chapter 5 : Identifying and Interpreting Diagnostic Messages

5-1: Diagnostic categories.....	5-2
5-1-1: Non critical failures	5-2
Effects on SFC operation	5-2
Summary of message.....	5-2
5-1-2: Critical failures	5-4
Effects on SFC operation	5-4
Summary of message.....	5-4
5-1-3: Communication errors	5-5
Effects on SFC operation	5-5
Summary of messages.....	5-5
5-1-4: Invalid key entry errors	5-5
Effects on SFC operation	5-5
Summary of messages.....	5-5
5-2: How to check diagnostic status.....	5-6
5-3: Message that interrupt SFC display	5-7
5-4: Interpreting messages.....	5-7

List of Figure & Table

Figures

Figure 1-1	Digital indicator	1-1
Figure 2-1	Name plate and conformance mark	2-3
Figure 2-2	Installing the transmitter	2-4
Figure 2-3	Equipment for line mounting	2-4
Figure 2-4	3-way manifold valve (Model MVG1)	2-7
Figure 2-5	Extension pipe.....	2-7
Figure 2-6	High pressure marking on center body	2-8
Figure 2-7	Piping for gas or liquid flow rate measurement.....	2-9
Figure 2-8	Pipe for gas or liquid flow measurement	2-10
Figure 2-9	Piping for steam flow measurement.....	2-11
Figure 2-10	Wiring	2-12
Figure 2-11	Supply voltage and load resistance characteristics	2-13
Figure 2-12	Connecting SFC	2-14
Figure 3-1	3-5
Figure 3-2	Items displayed on LCD	3-8
Figure 3-3	Flowchart of configuration data entry.....	3-9

Tables

Table 3-1	Operation modes of transmitter	3-2
Table 3-2	Items that are set and/or displayed in respective modes.....	3-3
Table 3-3	Summary of configuration data items	3-4
Table 3-4	Standard units of measure	3-13
Table 3-5	EU codes.....	3-26
Table 4-1	Modes and functions.....	4-1
Table 4-2	Calibration items in respective modes.....	4-2
Table 5-1	5-2

Chapter 1 : Functions, Configurations, and Structures of model JTD720A and SFC

1-1 : Digital indicator (optional)

The display unit of a digital indicator consists of the following:

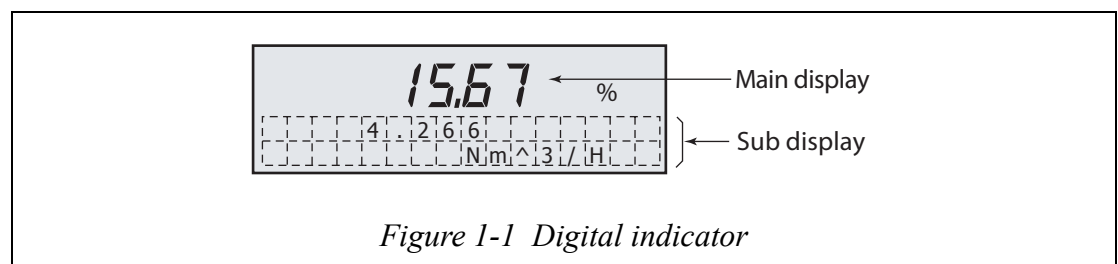

Main display

The main display shows an output of a transmitter in %.

The indications in a measurement mode and in a calibration mode are as follows:

Measurement mode

Compensated output is displayed in %.

~Note *When output conformity is “Linear”, the display indicates linear output. When output conformity is “Square root”, the display indicates square-rooted output.*

Calibration mode

DP mode: Displays 0 to 100% of setting DP range

PP mode: Displays 0 to 100% of setting PP range

PT mode: Displays 0 to 100% of setting PT range.

Sub display

Measurement mode

Displays flow rate with engineering unit.

When “Digital display with engineering unit scale” option is specified, the flow rate value is displayed on the upper column and the engineering unit is on the lower column in the sub display.

When “digital display with 0-100% scale” option is specified, the sub display is blank.

Example of the sub display:

			4	.	2	6	6							
								N	m	^	3	/	H	

Calibration mode

Differential pressure, static pressure or process temperature is displayed according to the mode. The mode is displayed on the lower column.

DP mode:

			2	.	6	7					k	P	a	
								D	P		M	O	D	E

- Displays present differential pressure in kPa.

PP mode:

			1	.	4	1					M	P	a	
								P	P		M	O	D	E

- Displays present differential pressure in MPa (gauge pressure).

PT mode:

			2	5	.	0					D	e	g	C
								P	T		M	O	D	E

- Displays present process temperature in °C.

Chapter 2 : Installation

Overview of chapter 2

Instructions for the installation of pipes and cables associated with this transmitter. Also covers installation of the transmitter. For users that are responsible for installation work.

2-1: Installation environment

2-1-1: General environmental conditions

Introduction

Install under environmental conditions specified here, to fully exploit transmitter performance over long periods.

Always install an explosion-proof transmitter where regulations demand such precautions.

Environmental conditions

Select a location to meet the following conditions:

- Temperature fluctuations should be as small as possible
- Avoid installing in locations that are exposed to radiated heat from other plant equipment.
- Insulate against freezing in the measured fluid or sealing liquid.
- Select a location where shocks and vibrations are as small as possible.
- Avoid installing in corrosive atmospheres.
- External zero-adjustment function is an option that may be subject to output fluctuations if installed near to sources of strong magnetic interference. Install such models at least 1 m remote from plant equipment producing strong magnetic interference as over 10 gauss measured where a motor or a pump is installed.

2-1-2: Environmental conditions for explosion-proof transmitter

Explosion-proof transmitter installation precautions

Explosion-proof transmitters have passed inspections at a public organization in compliance with Japanese Labor Safety and Hygiene Laws. As specified, use explosion-proof transmitters in hazardous locations. Smart Transmitters are available in two types of explosion-proof specifications: flameproof, special explosion-proof specifications and intrinsically-safe specifications.

Explosion-proof transmitters have a conformance mark that provides required information for explosion-proof performance. Install explosion-proof transmitters correctly, and follow the information on the name plate.

Environmental conditions for flameproof, special explosion-proof transmitter

Install a flameproof, special explosion-proof transmitter in locations that meet the following explosion class, ignition temperature, and hazardous environment class conditions:

- Explosion class and ignition temperature of gas:
IIB + H₂T₄ (IIB + H₂T₄: Gas equivalent to IIC, steam and Hydrogen
T4: Gas and steam whose ignition temperature is 135°C or higher.)
- Hazardous environment class
Class 1 location or Class 2 location
Installation in a Class 0 location prohibited.
- Temperature

Select a location where the temperature always stays under high limits specified by the conformance mark. AMBIENT TEMP refers to the ambient temperature of the transmitter and METER BODY TEMP refers to the temperature of the meter body that is in contact with the liquid. The low limit is -20°C for both ambient temperature and meter body temperature.

Temperature precautions

The transmitters explosion-proof performance cannot be guaranteed outside these temperature limits. If temperature should exceed the high limits, install insulation and ventilation, to maintain the effective operating temperature.

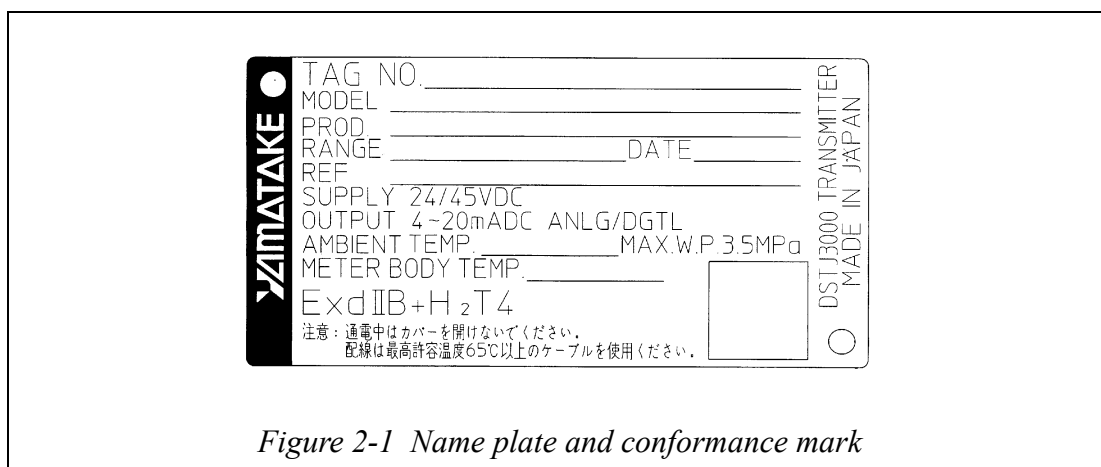

Reference document

Industrial Safety Institute of the Japanese Ministry of Labor, New Explosion-Proof Guidelines for Plant Electrical Facilities (Gas Explosion-Proof 1985)

2-1-3: Installing the transmitter

Before you install the transmitter

Prepare the following items:

- 2-inch pipe
- Mounting bracket (U-bolt, nut, mounting bolt) (Option)

The transmitter can be installed by the following two methods:

- Installation with pipe stanchion (Refer to Figure 2-2)
- Installation by line mounting (Refer to Figure 2-3)

In the both cases, fix the transmitter to a vertical or horizontal 50 mm pipe with a U-bolt using a mounting bracket. Mounting transmitter on a bracket using the four bolt holes on the reverse side of the pressure receiving part. Fix the pipe firmly to the foundation and make sure that it is stable. When you choose the line mounting method, provide equipment to be used for connecting a 2-inch pipe to the line pipe.

~Note *As for the procedure for mounting a transmitter on the 2-inch pipe, not that the sequence of assembling the transmitter, the bracket, and the 2-inch pipe depends on the installation direction.*

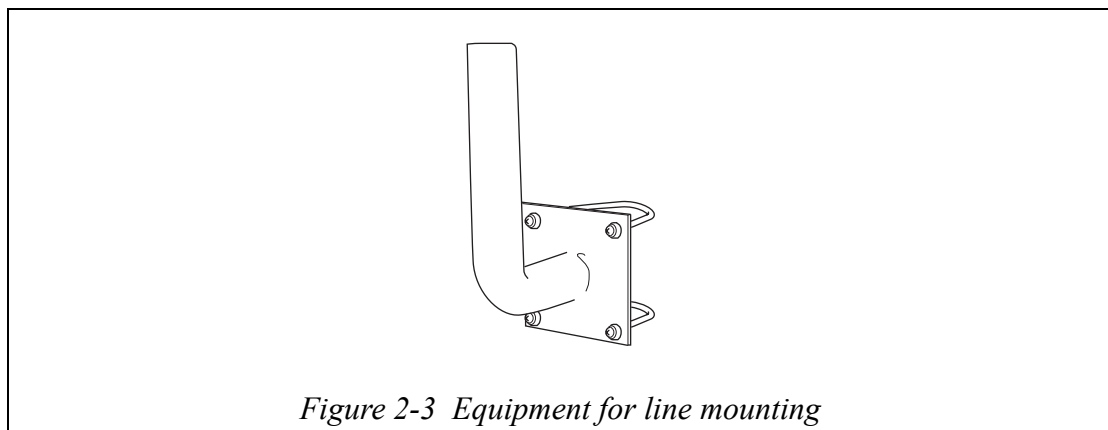
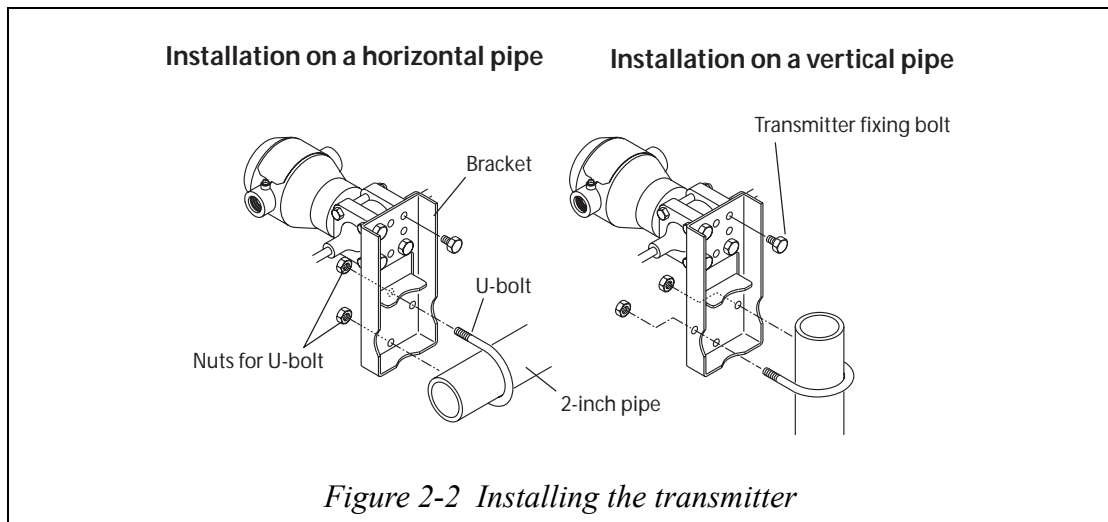

2-1-4: Transmitter main unit installation position

No special restriction is imposed on the installation position, it is the best to install the transmitter main unit in such a way as to set the pressure receiving diaphragm vertically. After installation, calibrate the zero point by the following procedure.





Perform zero point calibration by the following procedure:

Fix the high pressure and low pressure side diaphragms at the same height and make sure that the input pressure to the transmitter is uniform.

Turn off the sealed liquid temperature correction function for the calibration work.

Zero point calibration using SFC





Check that the input and the output are 0 kPa and 0%, respectively.

Step	Description	SFC screen
1	Turn on the power switch of the SFC make sure that the process is in the manual control mode, and press the  key	
2	Press the  key.	
3	Press the  and  keys in that order.	
4	Press the  key.	

If the SFC screen display is not 0 kPa and 0% in steps 3 and 4, respectively, perform zero calibration by steps 5 to 9.

(Continued)

If 0.005 kPa is displayed in step 3, perform calibration by the following procedure:

Step	Description	SFC screen
5	Press the  and  keys in that order." data-bbox="271 123 574 191"/>	
6	Press the  key." data-bbox="271 191 574 241"/>	
7	Press the  key." data-bbox="271 241 574 291"/>	
8	Press the  key." data-bbox="271 291 574 341"/>	
9	Repeat steps 3 and 4 to make sure that 0.00 is displayed. Zero point calibration has been completed." data-bbox="271 341 574 416"/>	

If the SFC screen display differs from the above, refer to Chapter 5 and the necessary action.

2-2: Piping

2-2-1: Piping considerations

Introduction

Piping method depends on such conditions as transmitter position and pipeline installation. It is generally sufficient to use a 3-way manifold valve and connect an extension pipe.

Since the model JTD720A has separate connector ports for high and low pressure, distinguish them correctly for installation work. A 3-way manifold valve is optional.

3-way method valve (option)

A regular, 3-way manifold valve is shown in the following illustration:

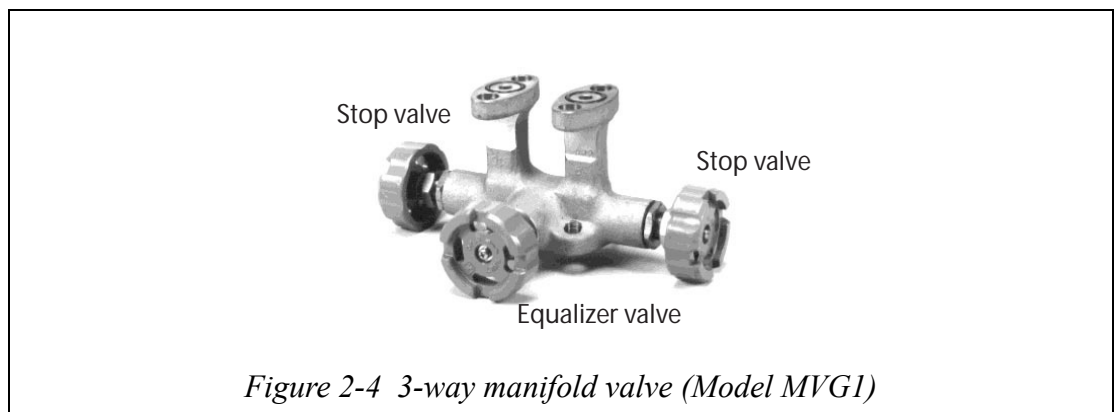

Extension pipe (option)

Both straight extension pipe and union extension pipe shown below, are available.

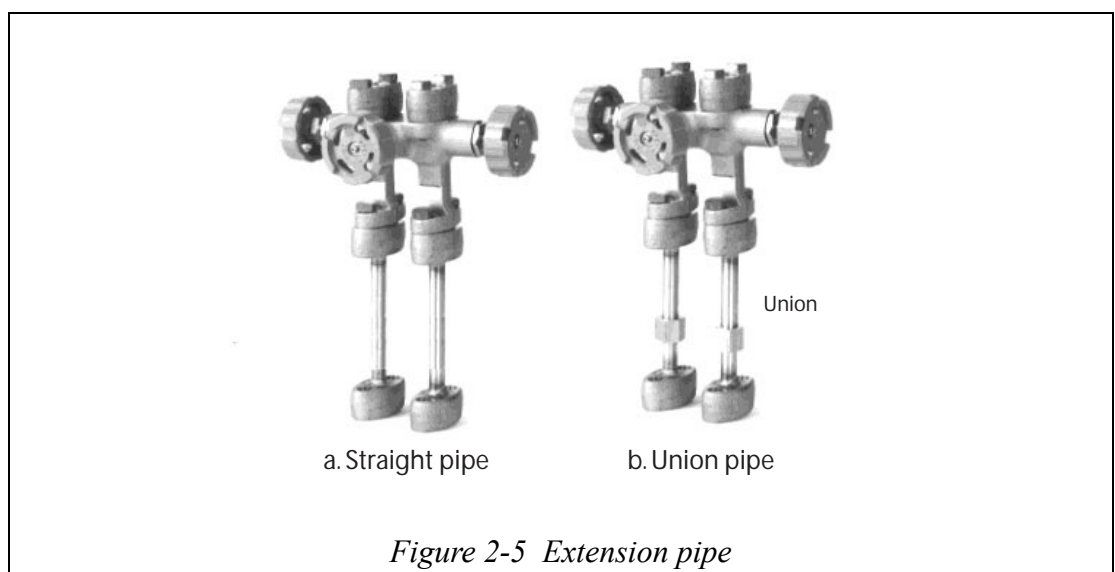

High-pressure marking

H indicates high pressure on the center body. Check the mark to ensure correct installation, during piping work. The low pressure side has no mark.

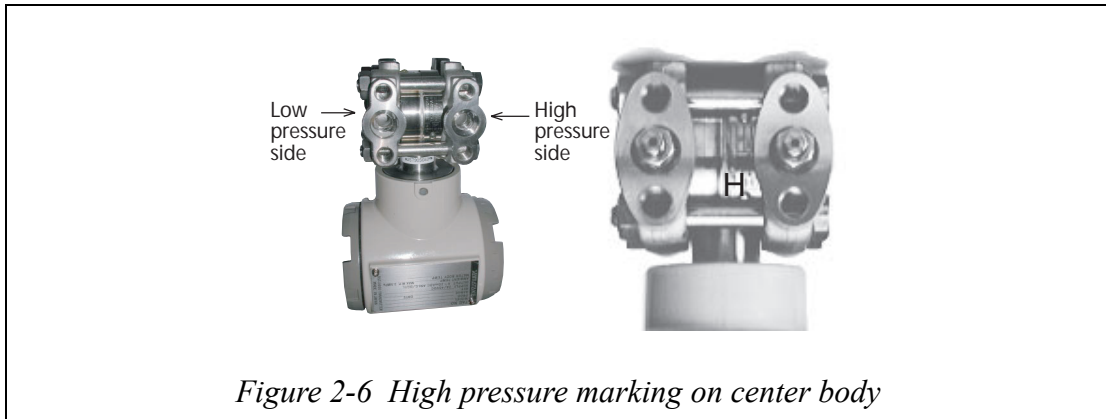

Pipe selection

Select a schedule number and nominal thickness for the connecting pipe leading from a process, based on such conditions as process pressure.

For example, use a 1/2-inch, steel pipe with a schedule number 80.

Materials and requirement

Prepare in advance the following parts and always refer to the illustration.

- 3-way manifold valve
- Pipe
- Main valve
- Union or flange
- Tee
- Drain valve
- Drain plug
- Vent plug
- Seat pot (for steam flow rate measurement only)

Piping for liquid gas or steam flow rate measurement

Important!

Incline the pipe at the differential pressure output part.

Indication symbol  in illustration: Lower position  Higher position.

After piping work, ensure that the connection pipe, the 3-way manifold valve, and the transmitter have no pressure leak.

The illustration shows a typical example of piping. This transmitter is located below the differential pressure output port of the process pipe.

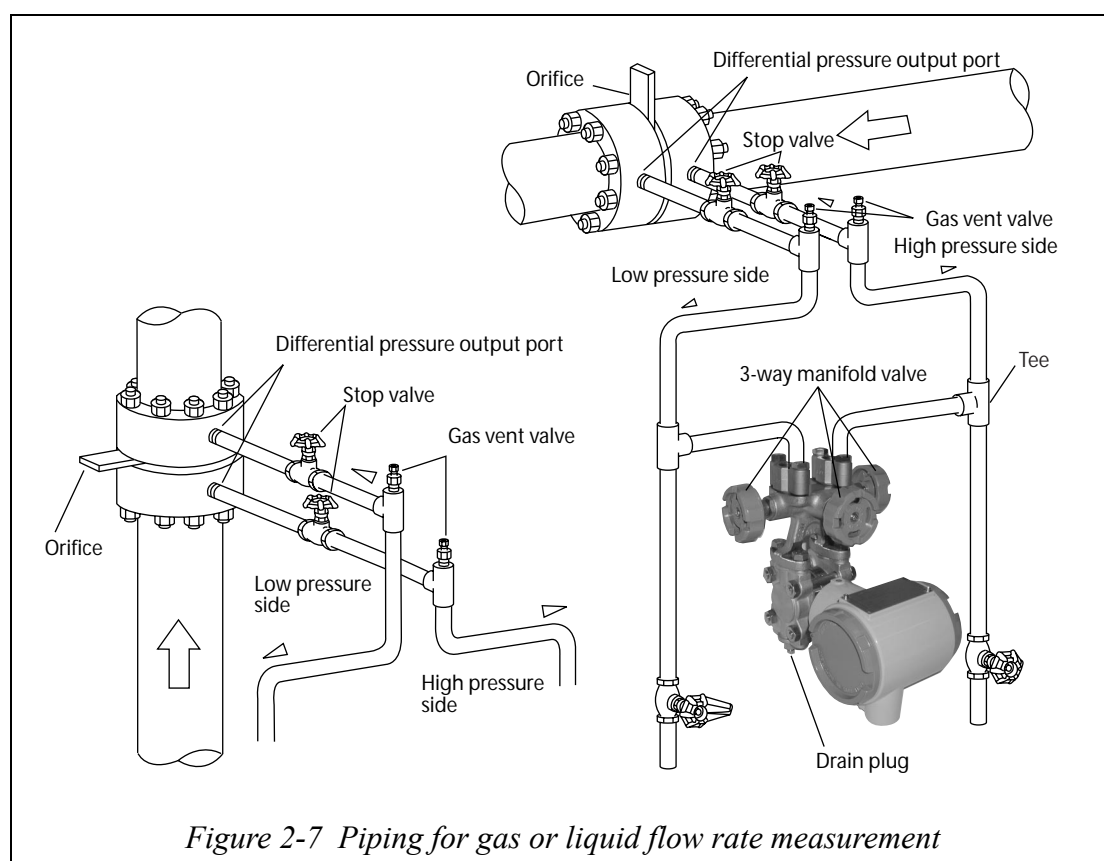

The illustration shows a typical example of piping for the transmitter located above the differential pressure port of the process pipe.

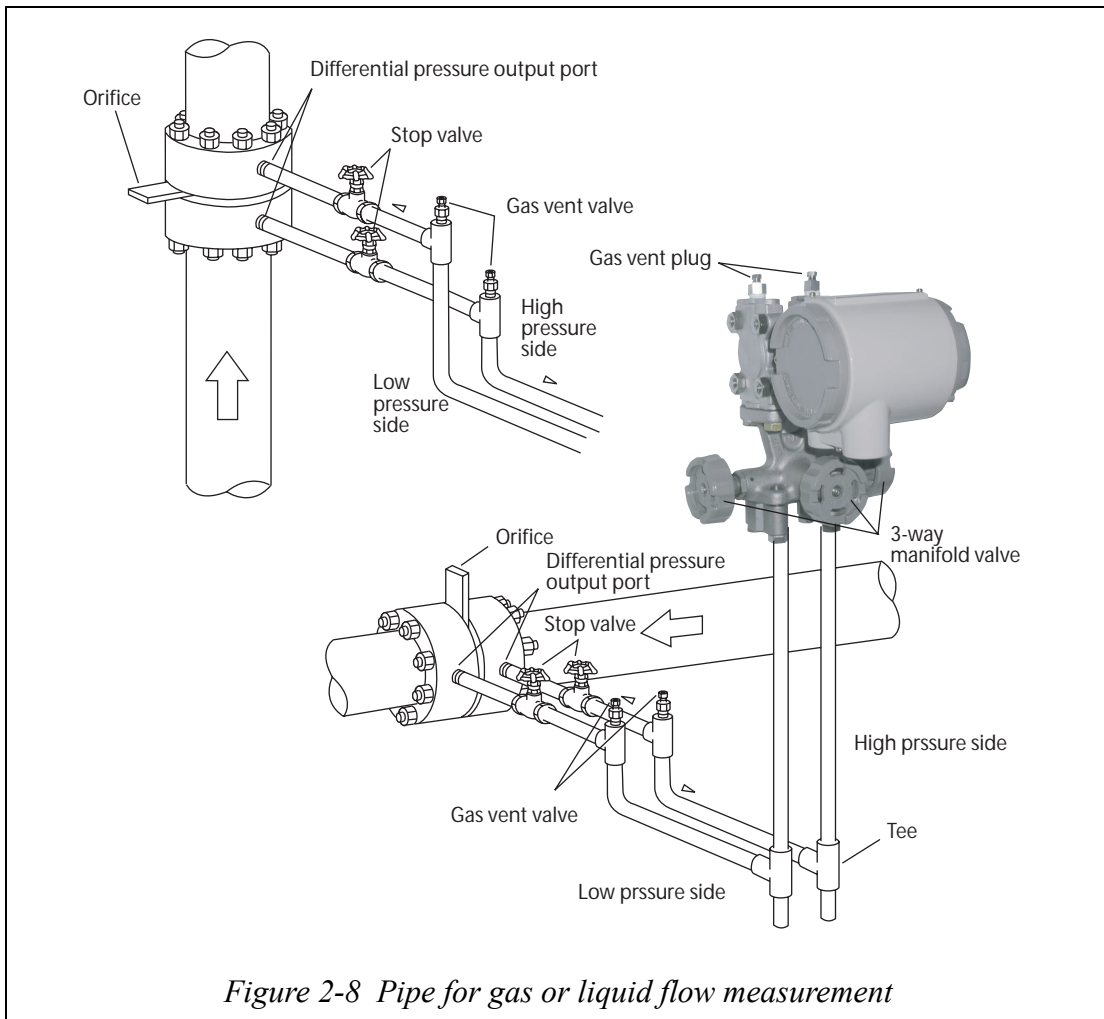

Figure 2-8 Pipe for gas or liquid flow measurement

The illustration shows a typical example of piping for steam flow that the transmitter is located below the differential pressure output port of the process pipe.

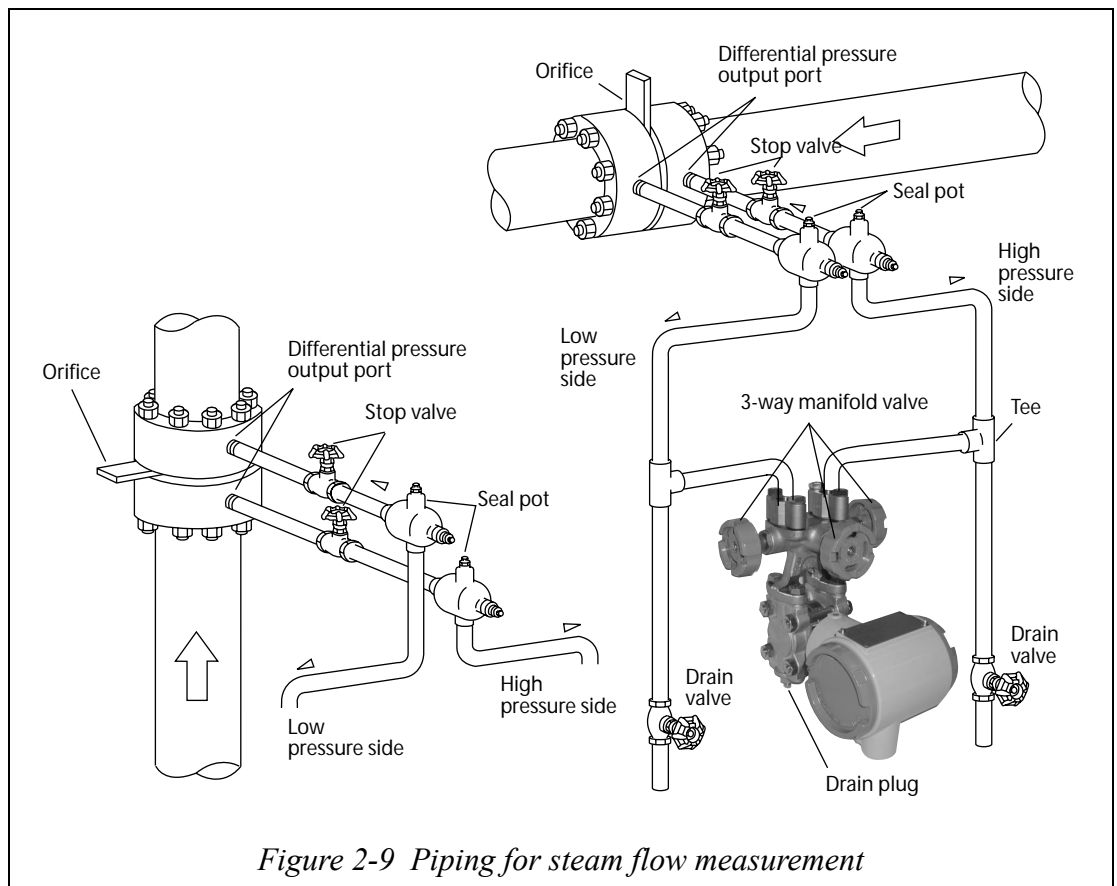

Figure 2-9 Piping for steam flow measurement

2-3: Electrical wiring

Introduction

This shows wiring instructions of the transmitters.

Wiring

Wire and cable this transmitter as shown in the instructions.

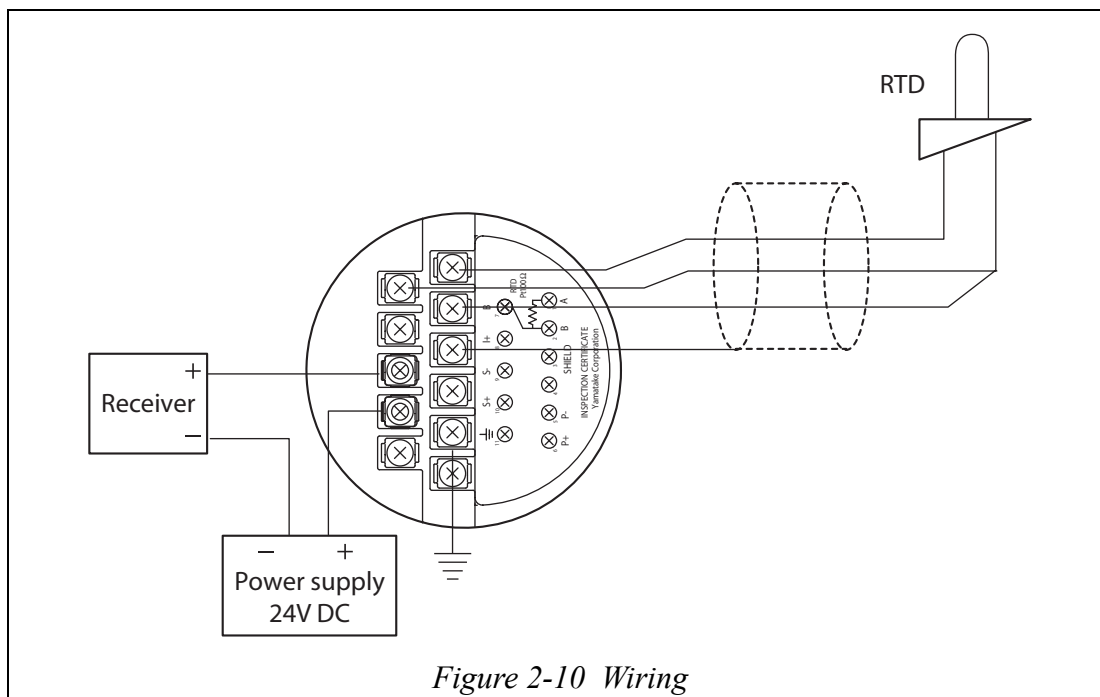

~Note *Load resistance of at least 250 Ω is required for SFC communication. If total load resistance of the receiver is less than 250 Ω install the necessary resistance to the loop.*

Conduit pipe

Lead cables into the transmitter case as follows;

Install a conduit pipe in the electrical conduit (G1/2 female thread) provided on the side of a transmitter, and lead cable through the pipe.

Seal the part that contacts with the conduit pipe using a sealing agent or a seal plug to positively prevent entry of water.

Install transmitter so that the cables lead into it, from the bottom.

If required, use a special elbow to change cabling direction.

Connect RTD (PT100 or JPT100) wires as shown in the figure using sealed cable. If temperature compensation is not required, this RTD is not necessary.

~Note

1. *It may take 5 minutes or more for stable input after connecting RTD to the transmitter.*
2. *The maximum cable length between the transmitter and the RTD is 20 m.*

Grounding

Two ground terminals are provided. One terminal is on the terminal, and the other is outside the transmitter. Ground either one.

Connect a ground terminal with a ground resistance not higher than 100 Ω .

Grounding is essential when installing explosion-proof transmitter.

Directly ground welding machine and transformer, for its power supply. Never connect such equipment by ground terminal to the stanchion pipe that holds a transmitter. Welding current may influence measurements.

Supply power

Confirm the relationship between the external load resistance and the supply voltage. As shown in the illustration, the relationship should be inside the shaded area.

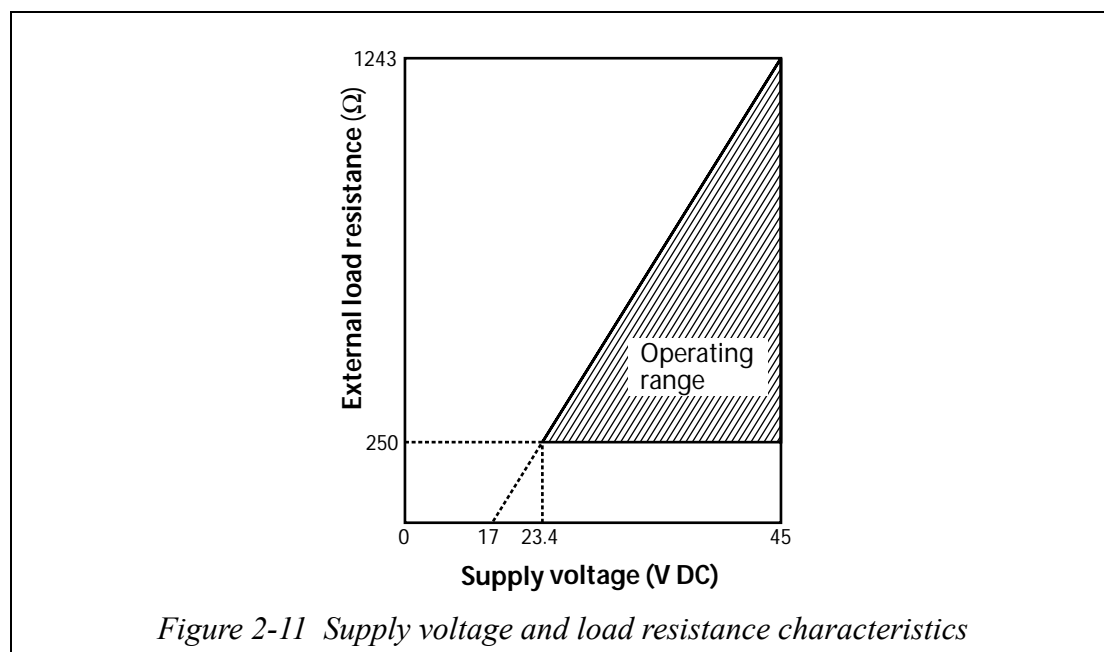

Connecting SFC

The figure shows how to connect an SFC to the transmitter.

Connect the SFC communication cables to the transmitter terminals as follows.

Red cable: Supply + terminal

Black cable: Supply - terminal

~Note *External load resistance must be at least 250 Ω for the communication.*

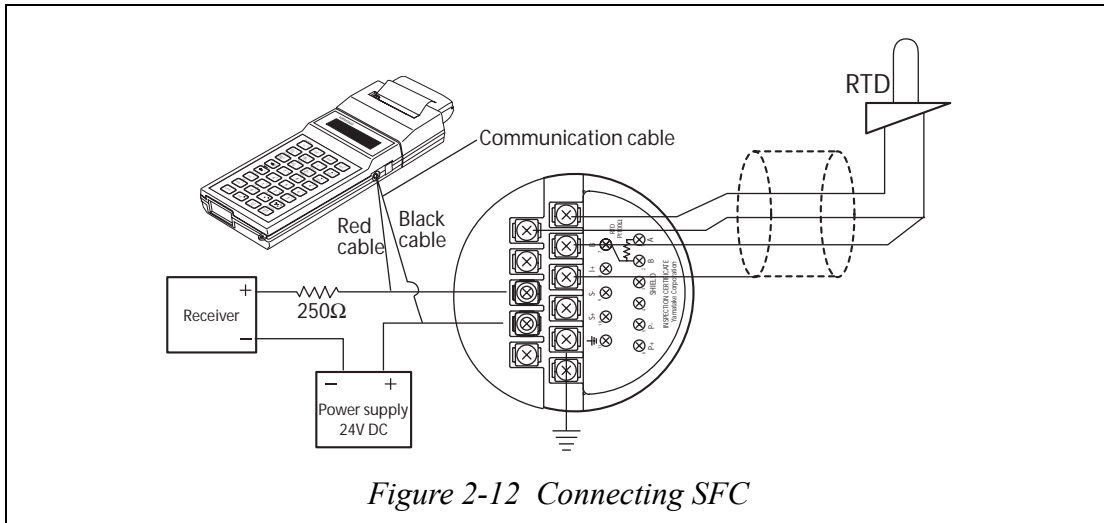

Chapter 3 : Using the SFC to configure and operate your transmitter

You must use the Smart Field Communicator (SFC) to set the desired operating characteristics for your transmitter, and to interact with it during operation.

We call the process of setting up the transmitter's operating characteristics "configuration". The actual operating parameters that are set or configured are referred to as the configuration data.

You can also set the transmitter to operate in either analog transmission mode or digital transmission mode. Note that configuration data varies for transmitters operating in digital transmission mode.

3-1: General information and procedures for configuration

The model JTD720 Differential Pressure Transmitter has six operation modes: MEASURE mode, DP mode, PP mode, PT mode, INPUT mode, and OUTPUT mode, as shown in Table 3-1. The DP, PP, PT modes are collectively referred to as CALIBRATION mode:

Table 3-1 Operation modes of transmitter

Mode		Description
MEASURE mode		The transmitter delivers an output signal which has been corrected for static pressure and temperature. Normally, the transmitter is run in this mode.
CALIBRATION mode	DP mode	The transmitter delivers an output current signal corresponding to the differential pressure input signal (4 mA (0%) for DP-LRV and 20 mA (100%) for DP-URV). This mode is used also for setting and calibration of the differential pressure sensor (setting and calibration of DP-LRV nad DP-URV).*1
	PP mode	The transmitter delivers and output current signal corresponding to the static pressure input signal (4 mA (0%) for PP-LRV and 20 mA (100%) for PP-URV). This mode is used also for setting and calibration of the static pressure sensor (setting and calibration of PP-LRV and PP-URV).*1
	PT mode	The transmitter delivers and output current siganal corresponding to the temperature input signal (4 mA (0%) for PT-LRV and 20 mA (100%) for PT-URV). This mode is used also for setting and calibration of the temperature sensor (setting and calibration of PT-LRV nad PT-URV).*1
INPUT mode		The transmitter accepts simulated differential pressure, static pressure and temperature signals, and delivers an output signal that has been corrected for static pressure and temperature.
OUTPUT mode		The transmitter acts as a constant-current signal source. This mode is also used for calibration of the D/A converter

~Note *1: For calibration, use a sufficiently accurate input signal. If you attempt zero calivration with a value more than 3% of URV (the maximum value for the measuring range of the sensor) or span calibration with a value more than 3% of the span that existed before calibration, the transmitter may exhibit symptoms similar to those exhibited by a transmitter experiencing a non-critical error.

The items that can be set and/or displayed on the transmitter from the SFC in different modes of operation are as shown in Table 3-2.

Two configuration data entry methods are available. One is to use the function keys of the SFC keyboard and then enter data with the numeric keys. The other is to press the CONFIGURATION key to call up a menu, select an item you may require, and then enter data with the numeric keys.

Table 3-2 Items that are set and/or displayed in respective modes

Configuration data item	Mode					
	MEAS.	DP	PP	PT	INPUT	OUTPUT
Tag No.	○	△	△	△	○	○
Damping time constant	○	○	○	○	○	○
Unit of measure for differential pressure	○	○	○	○	○	○
Unit of measure for static pressure	○	○	○	○	○	○
Unit of measure for temperature	○	○	○	○	○	○
Differential pressure LRV/URV	○	◎	△	△	○	△
Static pressure LRV/URV	△ Note3(◎)	△ Note3(◎)	◎	△ Note3(◎)	△ Note3(○)	△ Note5(◎)
Temperature LRV/URV	△ Note4(◎)	△ Note4(◎)	△ Note4(◎)	◎	△ Note4(○)	△ Note6(◎)
Type of output (linear or square root)	○	△	△	△	○	○
Design pressure (PP-REF)	○	△	△	△	○	△
Design pressure elevation (PP-ELV)	○	△	△	△	○	△
Design temperature (PT-REF)	○	△	△	△	○	△
Design temperature elevation (PT-ELV)	○	△	△	△	○	△
Temperature sensor type (PT/JPT)	○	△ Note7(○)	△ Note7(○)	○	○	△ Note7(○)
Constant-current value	Note 1	✕	✕	✕	✕	○
Simulated input value	Note 2	✕	✕	✕	○	✕
Save/restore	○	✕	✕	✕	✕	✕

◎: Setting (including by applied input) possible

○: Setting possible

△: Display alone possible

✕: Neither setting nor display possible

~Note 1. The OUTPUT mode will result as you set the constant-current value.

~Note 2. The INPUT mode will result as you set the simulated input value.

~Note 3. When static pressure value is output in DE.

~Note 4. When temperature value is output in DE.

~Note 5. When static pressure value is output in DE, while transmitter is not in the static pressure output mode.

~Note 6. When temperature value is output in DE, while transmitter is not in the temperature output mode.

~Note 7. When temperature value is output for DE output.

3-1-1: Items of configuration data

The items that make up configuration data are shown in Table 3-3. Applicable configuration data items depend on transmitter operation mode --- see Table 3-2.

Table 3-3 Summary of configuration data items

Item		Setting or selection
Transmitter tag No.		Up to 8 characters (Alphanumeric characters and symbols available on SFC keyboard can be used.)
Damping time constant		Any one of these value selections, in seconds: 0.00 0.16 0.32 0.48 1.0 2.0 4.0 8.0 16.0 32.0 Note that actual response time is the selected time plus approximately 0.4 seconds.
Unit of measure	Pressure unit	Pressure readings can be displayed in any of these standard engineering units: kPa MPa hPa Pa mbar bar inH ₂ O inHg PSI mmH ₂ O mH ₂ O kgf/cm ² gf/cm ² mmHg Suffixes “d”, “g” and “a” of the notations for pressure units denote “differential”, “gauge” and “absolute”, respectively.
	Temperature unit	Pressure readings can be displayed in any of these standard engineering units: °C °F K °R
Setting of differential pressure range (LRV/URV)	Lower range value LRV (DP-LRV) (Process input for 4 mA DC (0%) output)	Key-in desired value through SFC keyboard or set LRV to the value presently read by SFC. Available range: -100 kPa{-10000 mmH ₂ O} ≤ DP-LRV ≤ 100 kPa{10000 mmH ₂ O}
	Upper Range Value URV (DP-URV) (Process input for 20 mA DC (100%) output)	Key-in desired value through SFC keyboard or set URV to the value presently read by SFC. Available range: -100kPa{-10000mmH ₂ O} ≤ DP-URV ≤ 100kPa{10000mmH ₂ O}
Setting of static pressure range (LRV/URV)	Lower Range Value LRV (PP-LRV) (Process input for 4 mA DC (0%) output)	Key-in desired value through SFC keyboard or set LRV to the value presently read by SFC. Available range: 0 kPa{0 kgf/cm ² } abs. ≤ PP-LRV ≤ 3500 kPa{35 kgf/cm ² } abs.
	Upper Range Value URV (PP-URV) (Process input for 20 mA DC (100%) output)	Key-in desired value through SFC keyboard or set URV to the value presently read by SFC. Available range: 0 kPa{0 kgf/cm ² } abs. ≤ PP-URV ≤ 3500 kPa{35 kgf/cm ² } abs.

Table 3-3 Summary of configuration data items

Item		Setting or selection
Setting of temperature range (LRV/URV)	Lower Range Value LRV (PT-LRV) (Process input for 4 mA DC (0%) output)	Key-in desired value through SFC keyboard or set LRV to the value presently read by SFC. Available range: $-50^{\circ}\text{C} (-58^{\circ}\text{F}) \leq \text{PT-LRV} \leq 300^{\circ}\text{C} (582^{\circ}\text{F})$
	Upper Range Value URV (PT-URV) (Process input for 20 mA DC (100%) output)	Key-in desired value through SFC keyboard or set URV to the value presently read by SFC. Available range: $-50^{\circ}\text{C} (-58^{\circ}\text{F}) \leq \text{PT-URV} \leq 300^{\circ}\text{C} (582^{\circ}\text{F})$
Type of output		<p>Select linear or square root. After selection, you can further select a cutoff value (0 to 20%), type of dropout (linear or zero), and a flow rate measuring mode (default or expanded). (*1)</p>  <p style="text-align: center;"><i>Figure 3-1</i></p> <p>*1: Flow rate measuring mode Default: Normally, this mode is used. Expand: This mode is used when an expanded range is employed (for example, when the range is set close to the normal flow rate) or when an output representing a reverse current is needed (for example, when the transmitter is used in conjunction with a reversible orifice.)</p>
Design pressure (PP-REF)		Key-in desired value. Available range: $170\text{kPa} \{1.7\text{kgf/cm}^2\} \text{ abs.} \leq \text{PP-REF} \leq 3500\text{kPa} \{35\text{kgf/cm}^2\} \text{ abs.}$

Table 3-3 Summary of configuration data items

Item	Setting or selection
Design pressure elevation (PP-ELV) setting	Key-in desired value Available range: $0 \text{ kPa } \{0 \text{ kgf/cm}^2\} \leq \text{PP-ELV} \leq 3330 \text{ kPa } \{33.3 \text{ kgf/cm}^2\}$ Within limit of $\{\text{PP-REF}\} + \{\text{P-ELV}\} \leq 3500 \text{ kPa } \{35 \text{ kgf/cm}^2\}$
Design temperature (PT-REF) setting	Key-in desired value. Available range: $-50^\circ\text{C } (-50^\circ\text{F}) \leq \text{PT-REF} \leq 300^\circ\text{C } (582^\circ\text{F})$
Design temperature elevation (PT-ELV) setting	Key-in desired value. Available range: $-10^\circ\text{C } (-14^\circ\text{F}) \leq \text{PT-ELV} \leq +10^\circ\text{C } (50^\circ\text{F})$
Type of temperature sensor	Select Pt 100 Ω JPt 100 Ω
Constant-current value	Set the output current for operation in constant-current output mode, as a percentage with respect to the 4-20 mA span. Available range: -1.25% to 105%
Simulated input value	Available ranges: The same setting ranges available for differential pressure, static pressure, and temperature, respectively.
Time	Time can be set or modified. To be entered in the order: Year, Month, Day, Hour, and Minute.
Scratch pad (memo function)	The transmitter features two scratch pads. You can enter up to 16 alphanumeric characters in each.
Mode of output for digital transmission	You can select one of the following modes: Single-range: The PV value corresponding to the range set for the transmitter is indicated on the TDC controller display. Dual-range: The PV values in the two engineering units corresponding to the full range and working range are indicated on the TDC controller display. Single-range PV output and sensor temperature: The above single-range value and the value detected by the temperature sensor of the transmitter are indicated on the TDC controller display. Multi-range: The PV values corresponding to multiple ranges set for the transmitter are sent to the SPC or are indicated on the TDC display. Normally, the model JTD720 Differential Pressure Transmitter is run in this mode.

Table 3-3 Summary of configuration data items

Item	Setting or selection																													
<p>Data size for digital transmission (To be set when connected to TDC. For details, see Document IB2-2800-0400 “Operator’s Manual for STDCM”.)</p>	<p>Choose one of the following:</p> <p>4-byte size</p> <p>Byte 1: Output signal mode <table border="1" style="display: inline-table; vertical-align: middle;"><tr><td style="width: 20px; text-align: center;">1</td><td style="width: 20px; text-align: center;">2</td><td style="width: 20px; text-align: center;">3</td><td style="width: 20px; text-align: center;">4</td></tr><tr><td style="text-align: center;">FLAG</td><td style="text-align: center;">PV</td><td style="text-align: center;">PV</td><td style="text-align: center;">PV</td></tr></table></p> <p>Byte 2 to 4: PV value</p> <p>6-byte size</p> <p>Byte 1: Output signal mode <table border="1" style="display: inline-table; vertical-align: middle;"><tr><td style="width: 20px; text-align: center;">1</td><td style="width: 20px; text-align: center;">2</td><td style="width: 20px; text-align: center;">3</td><td style="width: 20px; text-align: center;">4</td><td style="width: 20px; text-align: center;">5</td><td style="width: 20px; text-align: center;">6</td></tr><tr><td style="text-align: center;">FLAG</td><td style="text-align: center;">PV</td><td style="text-align: center;">PV</td><td style="text-align: center;">PV</td><td style="text-align: center;">ID</td><td style="text-align: center;">DB</td></tr></table></p> <p>Byte 2 to 4: PV value</p> <p>Byte 5: Data type identifier</p> <p>Byte 6: Data being sent</p> <p>~Note <i>Approximate transmission rates.</i></p> <table style="margin-left: auto; margin-right: auto;"> <tr> <td></td> <td style="text-align: center;">4-byte size</td> <td style="text-align: center;">6-byte size</td> </tr> <tr> <td style="text-align: center;">PV value</td> <td style="text-align: center;">3 rpts/sec</td> <td style="text-align: center;">2.5 repts/sec</td> </tr> <tr> <td style="text-align: center;">Temperature</td> <td style="text-align: center;">1 rpt/ 2.5 sec</td> <td style="text-align: center;">1 rpt/ 3 sec</td> </tr> </table>	1	2	3	4	FLAG	PV	PV	PV	1	2	3	4	5	6	FLAG	PV	PV	PV	ID	DB		4-byte size	6-byte size	PV value	3 rpts/sec	2.5 repts/sec	Temperature	1 rpt/ 2.5 sec	1 rpt/ 3 sec
1	2	3	4																											
FLAG	PV	PV	PV																											
1	2	3	4	5	6																									
FLAG	PV	PV	PV	ID	DB																									
	4-byte size	6-byte size																												
PV value	3 rpts/sec	2.5 repts/sec																												
Temperature	1 rpt/ 2.5 sec	1 rpt/ 3 sec																												
<p>Failsafe mode for digital transmission (To be set when connected to TDC. For details, see Document IB2-2800-0400 “Operator’s Manual for STDCM”.)</p>	<p>The failsafe action mentioned here is for the STDC card --- it is not for the transmitter. It can be set either on the input side or output side of the STDC card. Burnout direction is high, low or hold.</p> <table border="1" style="width: 100%; border-collapse: collapse;"> <thead> <tr> <th style="text-align: left;">Type of failsafe</th> <th style="text-align: left;">SFC display</th> <th style="text-align: left;">Burnout direction</th> </tr> </thead> <tbody> <tr> <td rowspan="3" style="vertical-align: top;">STDC input-side setting</td> <td>F/S = B/O Lo</td> <td>Low limit</td> </tr> <tr> <td>F/S = B/O Hi</td> <td>Low limit</td> </tr> <tr> <td>F/S = LKG</td> <td>Hold (STDC input signal is held at the last known good process value.)</td> </tr> <tr> <td rowspan="3" style="vertical-align: top;">STDC output-side setting (STDC outputsignal is held at the last known good process value.)</td> <td>F/S = FSO, B/O Lo</td> <td>Low limit</td> </tr> <tr> <td>F/S = FSO, B/O Hi</td> <td>Low limit</td> </tr> <tr> <td>F/S = FSO, LKG</td> <td>Hold</td> </tr> </tbody> </table> <p>F/S: FAIL SAFE B/O: BURN OUT LKG: LAST KNOWN GOOD VALUE FSO: FREEZE SLOT OUTPUT</p>	Type of failsafe	SFC display	Burnout direction	STDC input-side setting	F/S = B/O Lo	Low limit	F/S = B/O Hi	Low limit	F/S = LKG	Hold (STDC input signal is held at the last known good process value.)	STDC output-side setting (STDC outputsignal is held at the last known good process value.)	F/S = FSO, B/O Lo	Low limit	F/S = FSO, B/O Hi	Low limit	F/S = FSO, LKG	Hold												
Type of failsafe	SFC display	Burnout direction																												
STDC input-side setting	F/S = B/O Lo	Low limit																												
	F/S = B/O Hi	Low limit																												
	F/S = LKG	Hold (STDC input signal is held at the last known good process value.)																												
STDC output-side setting (STDC outputsignal is held at the last known good process value.)	F/S = FSO, B/O Lo	Low limit																												
	F/S = FSO, B/O Hi	Low limit																												
	F/S = FSO, LKG	Hold																												

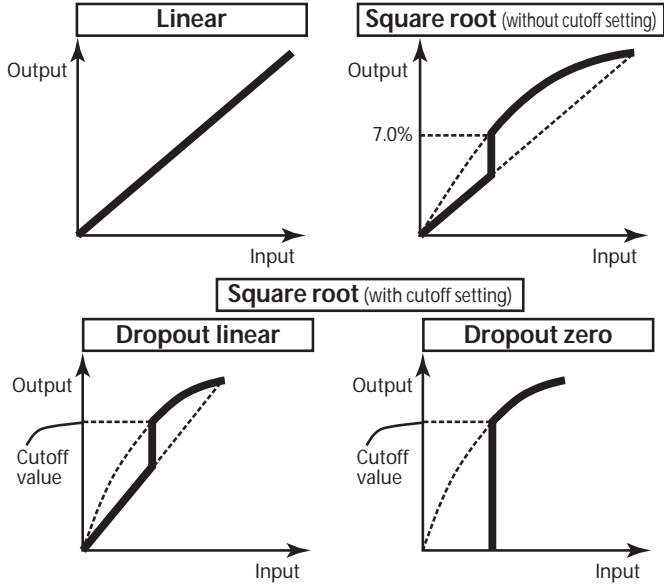
3-1-2: Outline of SFC display

The SFC has a 16-column, 2-row LCD display. The top row usually displays transmitter model number, display subject, and tag number.

When the transmitter is in a critical error state, the message “CRITICAL STATUS” appears on the display. When the transmitter is in a non-critical error state, the symbol “#” appears at the right side of the top row of the display.

When a communication error occurs, the type of the error and its probable cause appear on the display.

When the transmitter is in DP, PP, PT, or INPUT mode, the mode name appears instead of the tag number in the top row of the display. When the battery voltage drops, a colon appears in the 8-th column of the top row as shown in Figure 3-2.

	1	2	3	4	5	6	7	8	9	10	11	12	13	14	15	16
Top row	F	F	F	F	F	F	F	:	X	X	X	X	X	X	X	#
Bottom row	N	N	N	N	N	N	N	@	U	U	U	U	U	U	U	U



FFFFFFFF : Model name or subject of display.
 : : Battery voltage low.
 XXXXXXXX# : Tag number or mode name.
 (“DP-MODE” for DP mode,
 “PP-MODE” for PP mode,
 “PT-MODE” for PT mode,
 “IN-MODE” for INPUT mode)
 # : Non-critical error
 NNNNNNN\$: Numeric value (4.5 digits)
 (When in range setting, if input is 100 kPa {1 kgf/cm²}, display will be 99.99 kPa {0.9999 kgf/cm²}; if input is 200 kPa {2 kgf/cm²}, display will be 199.99 kPa {1.9999 kgf/cm²}.)
 @ : Denotes a simulated input.
 UUUUUUU : Unit of measure

Figure 3-2 Items displayed on LCD

3-1-3: How to enter configuration data

You can enter configuration data (as shown in “3-1-1: Items of configuration data”) into either the SFC’s memory or the transmitter’s memory. A flowchart of configuration data entry procedure is shown in Figure 3-3.

In Figure 3-3, the items further than “ (other settings, etc.)” are those which are not indicated on the SFC keyboard. To select these items, you must first press the

 key and then call up the pertinent display for entry with the  and  keys.

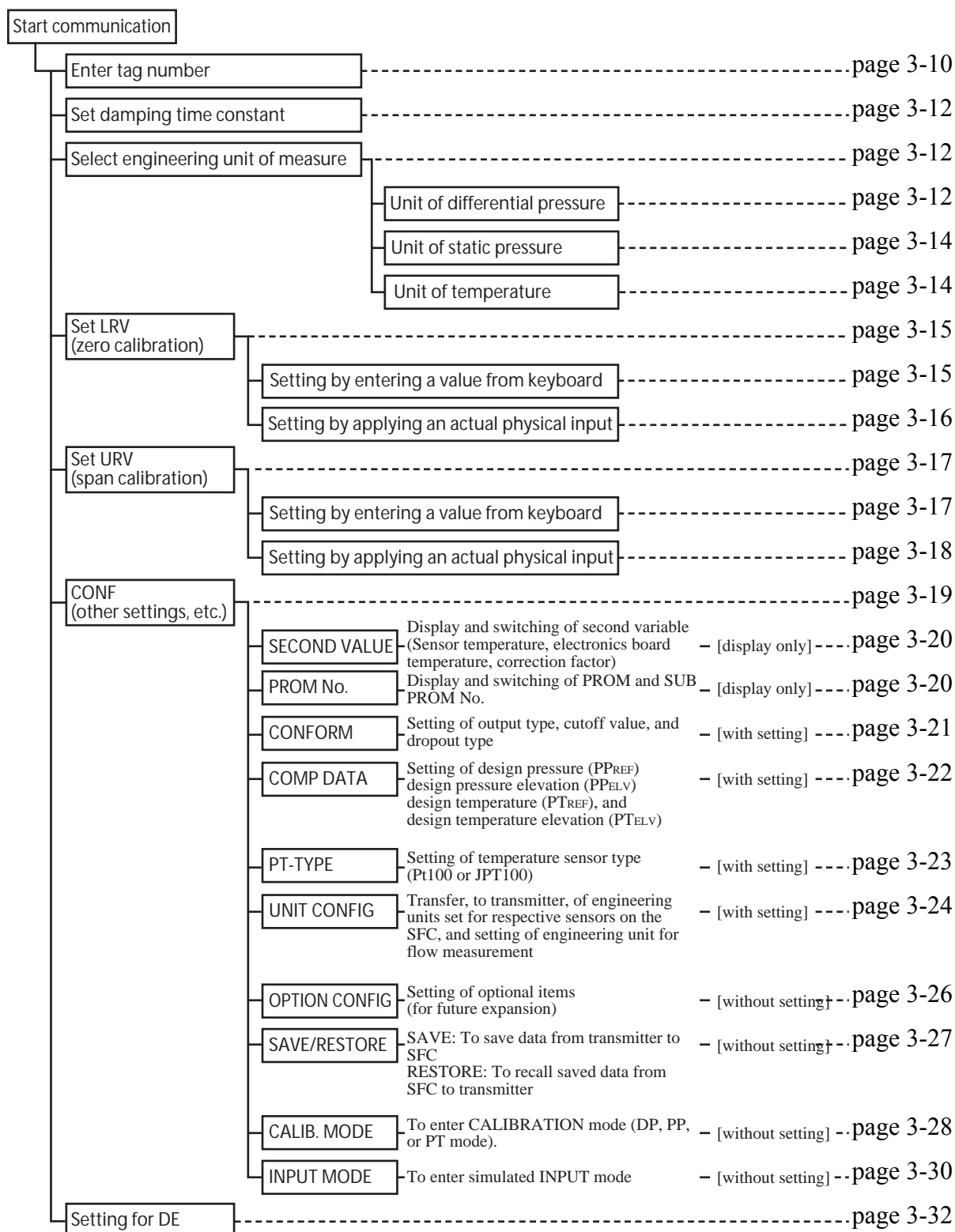









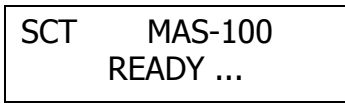

Figure 3-3 Flowchart of configuration data entry

Entering a tag number (establishing communications)



Key	SFC display	Description
<p>DE READ </p> <p>(Analog output)</p> <p></p> <p>DE READ </p> <p>(DE output)</p>	<p style="text-align: right;">*1</p> <div style="border: 1px solid black; padding: 5px; margin-bottom: 10px;">TAG No. WORKING ...</div> <p>①</p> <div style="border: 1px solid black; padding: 5px; margin-bottom: 10px;">SCT TAG No. LIN DP XXXXXXXX</div> <p style="text-align: center;">② ③ ⑤ ④</p> <p>⑥</p> <div style="border: 1px solid black; padding: 5px;">SCT DE TAG No. SQRT DP XXXXXXXX</div> <p style="text-align: right;">*1</p>	<p>① Model name: (Smart Corrected Transmitter)</p> <p>② Type of output: LIN (linear output) SQRT (square root output)</p> <p>③ Type of transmitter DP (differential pressure transmitter)</p> <p>④ Tag No. Up to eight alphanumeric caharacters. Factory default is “XXXX XXXX”.</p> <p>⑤ Cursor</p> <p>⑥ DE (digital output)</p> <p>*: Communication time Analog output: Approx. 40 sec. Digital output: Approx. 90 sec.</p>
<p></p>	<p style="text-align: center;">(Numeric mode)</p> <div style="border: 1px solid black; padding: 5px; margin-bottom: 10px;">SCT TAG No. LIN DP XXXX XXXX</div> <p style="text-align: center;">(Alphabetic mode)</p> <div style="border: 1px solid black; padding: 5px;">ST TAG No. LIN DP ■XXX XXXX</div>	<p>Selects numeric mode or alphabetic mode, alternately. (Alphabetic mode is for entry of alphabetic characters or symbols indicated at the upper right of keys. When in this mode the cursor blinks.)</p>
<p></p>	<div style="border: 1px solid black; padding: 5px;">SCT TAG No. LIN DP MAS-11<u>Q</u></div>	<p>For entry of alphanumeric characters for tag numbers. (Here “MAS-110” is the tag number.)</p>
<p></p> <p>A ↔ DE</p> <p></p> <p></p>	<div style="border: 1px solid black; padding: 5px; margin-bottom: 10px;">SCT TAG No. LIN DP MAS-11<u>Q</u></div> <div style="border: 1px solid black; padding: 5px;">SCT TAG No. LIN DP MAS-10<u>Q</u></div>	<p>To modify the tag number, move the cursor to the character to be modified and overwrite it. (In this example, “MAS-110” is modified to “MAS-100”.)</p>
<p>NON-VOL </p>	<div style="border: 1px solid black; padding: 5px; margin-bottom: 10px;">SCT TAG No. WORKING...</div> <div style="border: 1px solid black; padding: 5px;">SCT TAG No. LIN DP MAS-10<u>Q</u></div>	<p>Enter the above tag number into the transmitter memory and SFC memory.</p>

Clearing the present display

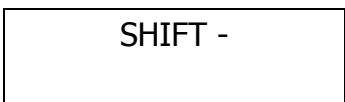

Key	SFC display	Description
		Ready to accept entry from keyboard.

To manually save configuration data into non-volatile memory (NVM)

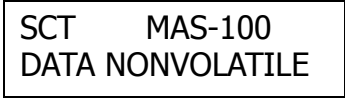
Approximately 30 seconds after any change of configuration data in the transmitter's working memory, the data is automatically transferred from working memory and saved in non-volatile memory (NVM), where the data is retained even when equipment power is turned off. However, you may speed data saving with the following procedure if you want to turn off equipment power sooner and yet be sure that the data has been saved.



Key	SFC display	Description
		Saves data in NVM (This takes approximately 8 seconds.)
		

Selecting a damping time constant



Key	SFC display	Description
	DAMPING MAS-100 0.0 SECONDS	Displays present damping time constant
 	DAMPING MAS-100 0.16 SECONDS : DAMPING MAS-100 32.0 SECONDS	For the damping time constant, select one of the following: 0.0 0.16 0.32 0.48 1.0 2.0 4.0 8.0 16.0 32.0

Selecting an engineering unit of measure

A unit of measure is selected for the process variable (differential pressure, static pressure, or temperature) whose data was displayed immediately before you pressed the  key.

For example, if you want to change units for static pressure measurement, you must let the instrument display LRV/URV or INPUT/OUTPUT data and select data on static pressure with the  key and then press the  key.

Selecting a unit for differential pressure measurement

To select an engineering unit of measure for differential pressure hold down the  key and press the  key, or let the instrument display a differential pressure data item and then press the  key.



Key	SFC display	Description
	DP-UNIT MAS-100 kPa d	Displays present unit of measure for differential pressure.
  	DP-UNIT MAS-100 MPa d : DP-UNIT MAS-100 mmHg d	Select one of the differential pressure units shown in Table 3-4.

Table 3-4 Standard units of measure

Differential pressure		Static pressure				Temperature
kPa	d	kPa	g	kPa	a	°C
MPa	d	MPa	g	MPa	a	°F
hPa	d	hPa	g	hPa	a	K
Pa	d	Pa	g	Pa	a	°R
mbar	d	mbar	g	mbar	a	-
bar	d	bar	g	bar	a	-
inH ₂ O	d	inH ₂ O	g	inH ₂ O	a	-
inHg	d	inHg	g	inHg	a	-
PSI	d	PSI	g	PSI	a	-
mmH ₂ O	d	mmH ₂ O	g	mmH ₂ O	a	-
mH ₂ O	d	mH ₂ O	g	mH ₂ O	a	-
kgf/cm ²	d	kgf/cm ²	g	kgf/cm ²	a	-
gf/cm ²	d	gf/cm ²	g	gf/cm ²	a	-
mmHg	d	mmHg	g	mmHg	a	-

kPa = Kilopascals

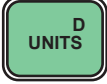
MPa = Megapascals

gf/cm² = Grams force/cm²

kgf/cm² = Kilogram force/cm²

°C = Degrees celsius

°F = Degrees Fahrenheit

K = Kelvin

°R = Degrees Rankine





Suffixes d: Differential pressure

g: Gauge pressure

a: Absolute pressure





Selecting a unit for static pressure measurement

To select an engineering unit of measure for static pressures, proceed as shown below. This procedure is effective only when the instrument is displaying data on static pressure.

Key	SFC display	Description
	PP-UNIT MAS-100 kPa g	Displays present unit of measure for static pressure.
  	PP-UNIT MAS-100 kPa g PP-UNIT MAS-100 mmHg g	Select one of the differential pressure units shown in Table 3-4.
DE CONF. 	PP-UNIT MAS-100 kPa g PP-UNIT MAS-100 kPa g	Switches the display between absolute pressure and gauge pressure. The gauge pressure display by SFC is as calculated with “Absolute pressure minus 101.3 kPa {1.033 kgf/cm ² }”. So, if the actual atmospheric pressure is not accurately at 1 atmospheric pressure (101.3 kPa {1.033 kgf/cm ² }), a corresponding inaccuracy will be introduced into the measured values. All pressure data processing work within the transmitter is done in terms of absolute pressures.

Selecting a unit for temperature measurement

To select an engineering unit of measure for static pressures, proceed as shown below. This procedure is effective only when the instrument is displaying temperature data.

Key	SFC display	Description
	PT-UNIT MAS-100 °C	Displays present unit of measure for temperature.
  	PT-UNIT MAS-100 °F PT-UNIT MAS-100 K	Select one of the temperature units shown in Table 3-4.







The data on units selected as above can be stored in the transmitter’s memory as shown in page 3-24.

Setting Lower Range Value LRV (Zero Adjustment)





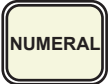

You can set the LRV (input value corresponding to 0% (4 mA DC) output) either (1), by keying-in the desired values through the SFC keyboard or (2), by applying the corresponding physical pressure directly to the transmitter.

~Note *Ability to set depends on the mode. Refer to “Table 3-2 Items that are set and/or displayed in respective modes”.*

Setting of LRV by keying-in desired values through SFC

Key	SFC display	Description
	<div style="border: 1px solid black; padding: 5px; display: inline-block;"> DP-LRV MAS-100 <u>0</u>.01 kPa d ↑ Cursor </div>	Immediately after you press the  key, or when differential pressure data has been displayed. (If static pressure data has been displayed, PP-LRV will appear; if temperature data has been displayed, PT-LRV will appear)
DE CONF. 	<div style="border: 1px solid black; padding: 5px; display: inline-block;"> PP-LRV MAS-100 <u>0</u>.000 kPa g </div> <div style="border: 1px solid black; padding: 5px; display: inline-block;"> PT-LRV MAS-100 <u>0</u>.0 °C </div>	With the  key, select a sensor (DP, PP, or PT sensor) to be calibrated. (Here, let's assume you select the DP sensor.)
	<div style="border: 1px solid black; padding: 5px; display: inline-block;"> DP-LRV MAS-100 0.0 kPa d </div>	Key-in a value corresponding to the LRV.
NON-VOL 	<div style="border: 1px solid black; padding: 5px; display: inline-block;"> DP-LRV MAS-100 0.000 kPa d </div>	The new LRV is entered in both the transmitter's memory and SFC's memory, and is displayed on the SFC.

Setting of LRV by applying an actual physical pressure







Key	SFC display	Description
	<div style="border: 1px solid black; padding: 5px; display: inline-block;"> DP-LRV MAS-100 0 . 0 1 kPa d </div> ↑ Cursor	Immediately after you press the  key, or when differential pressure data has been displayed. (If static pressure data has been displayed, PP-LRV will appear; if temperature data has been displayed, PT-LRV will appear)
	<div style="border: 1px solid black; padding: 5px; display: inline-block;"> PP-LRV MAS-100 0 . 0 0 0 kPa g </div> <div style="border: 1px solid black; padding: 5px; display: inline-block;"> PT-LRV MAS-100 0 . 0 °C </div>	With the  key, select a sensor (DP, PP, or PT sensor) to be calibrated. (Here, let's assume you select the DP sensor.)
	<div style="border: 1px solid black; padding: 5px; display: inline-block;"> DP-LRV MAS-100 SET DP-LRV ? </div>	Apply a pressure corresponding to the LRV. Press the  key.
	<div style="border: 1px solid black; padding: 5px; display: inline-block;"> DP-LRV MAS-100 0 . 2 3 kPa d </div>	The new LRV is entered in both the transmitter's memory and SFC's memory, and is displayed on the SFC.

Setting Upper Range Value URV (Adjusting Span)





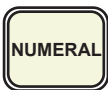

You can set the URV (input value corresponding to 100% (20 mA DC) output) either (1), by keying-in the desired value through the SFC keyboard or (2), by applying the corresponding physical pressure directly to the transmitter.

~Note *Ability to set depends on the mode. Refer to “Figure 3-3 Flowchart of configuration data entry”.*

Setting of URV by keying-in desired values through SFC

Key	SFC display	Description
	<div style="border: 1px solid black; padding: 5px; display: inline-block;"> DP-LRV MAS-100 10.00 kPa d ↑ Cusor </div>	Immediately after you press the  key, or when differential pressure data has been displayed. (If static pressure data has been displayed, PP-URV will appear; if temperature data has been displayed, PT-URV will appear)
	<div style="border: 1px solid black; padding: 5px; display: inline-block;"> PP-URV MAS-100 10.00 kPa g </div> <div style="border: 1px solid black; padding: 5px; display: inline-block;"> PT-URV MAS-100 100 °C </div>	With the  key, select a sensor (DP, PP, or PT sensor) to be calibrated. (Here, let's assume you select the DP sensor.)
	<div style="border: 1px solid black; padding: 5px; display: inline-block;"> DP-URV MAS-100 20.00 kPa d </div>	Key-in a value corresponding to the URV.
	<div style="border: 1px solid black; padding: 5px; display: inline-block;"> DP-URV MAS-100 20.00 kPa d </div>	The new URV is entered in both the transmitter's memory and SFC's memory, and is displayed on the SFC.

Setting of URV by applying an actual physical pressure

Key	SFC display	Description
	<div style="border: 1px solid black; padding: 5px; margin-bottom: 5px;"> DP-LRV MAS-100 10.00 kPa d </div> ↑ Cursor	Immediately after you press the  key, or when differential pressure data has been displayed. (If static pressure data has been displayed, PP-URV will appear; if temperature data has been displayed, PT-URV will appear)
	<div style="border: 1px solid black; padding: 5px; margin-bottom: 5px;"> PP-URV MAS-100 10.00 kPa g </div> <div style="border: 1px solid black; padding: 5px;"> PT-URV MAS-100 100 °C </div>	With the  key, select a sensor (DP, PP, or PT sensor) to be calibrated. (Here, let's assume you select the DP sensor.)
	<div style="border: 1px solid black; padding: 5px;"> DP-URV MAS-100 SET DP-LRV ? </div>	Apply a pressure corresponding to the URV. Press the  key.
	<div style="border: 1px solid black; padding: 5px;"> DP-URV MAS-100 12.00 kPa d </div>	The new URV is entered in both the transmitter's memory and SFC's memory, and is displayed on the SFC.

Other settings

Procedure to display or set the item ① to ⑩ shown right.

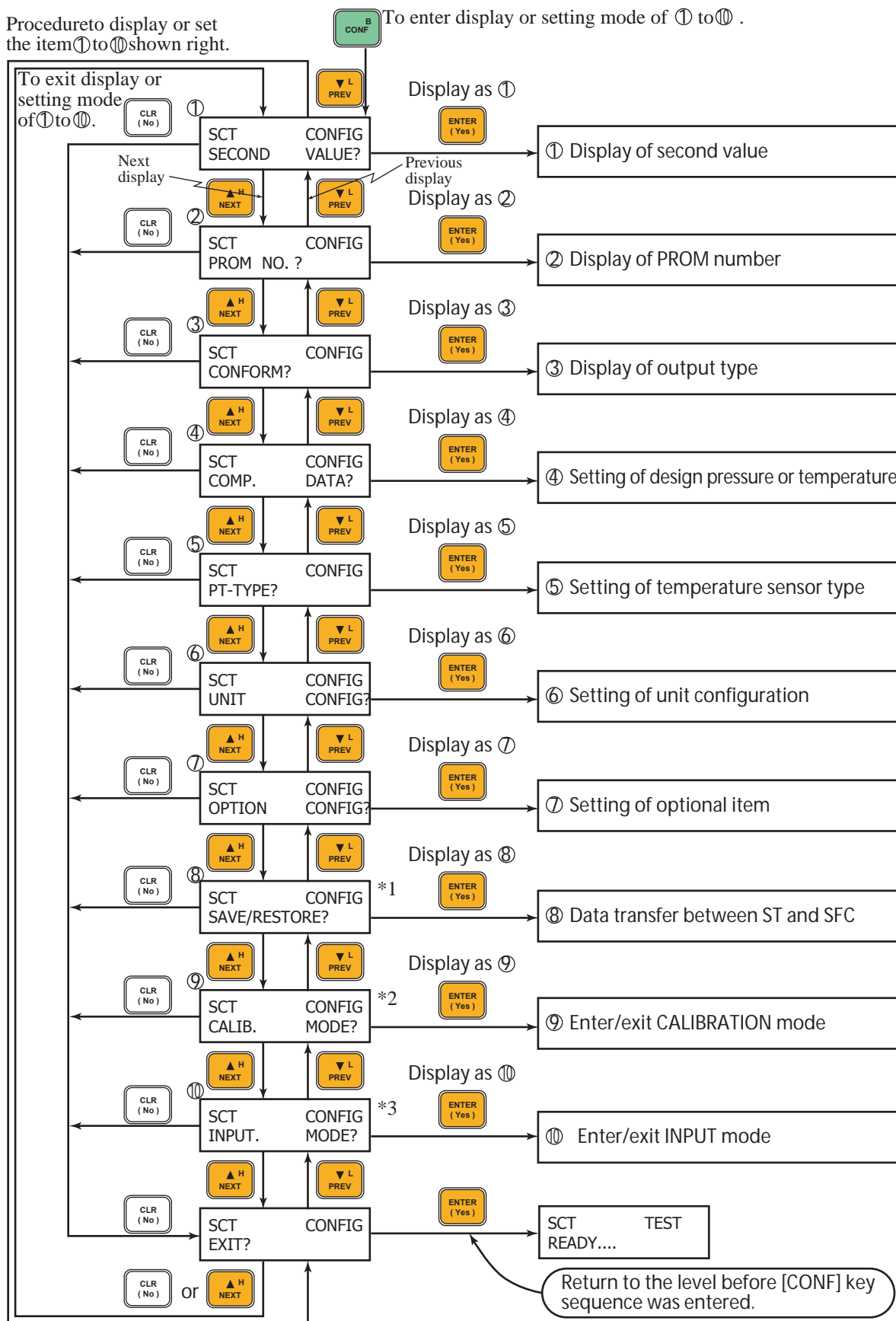

*1: Displayed only when in the MEASURE mode.

*2: Displayed only when in the MEASURE, DP, PP or PT mode.

*3: Displayed only when in the MEASURE or INPUT mode.

① Display of second value

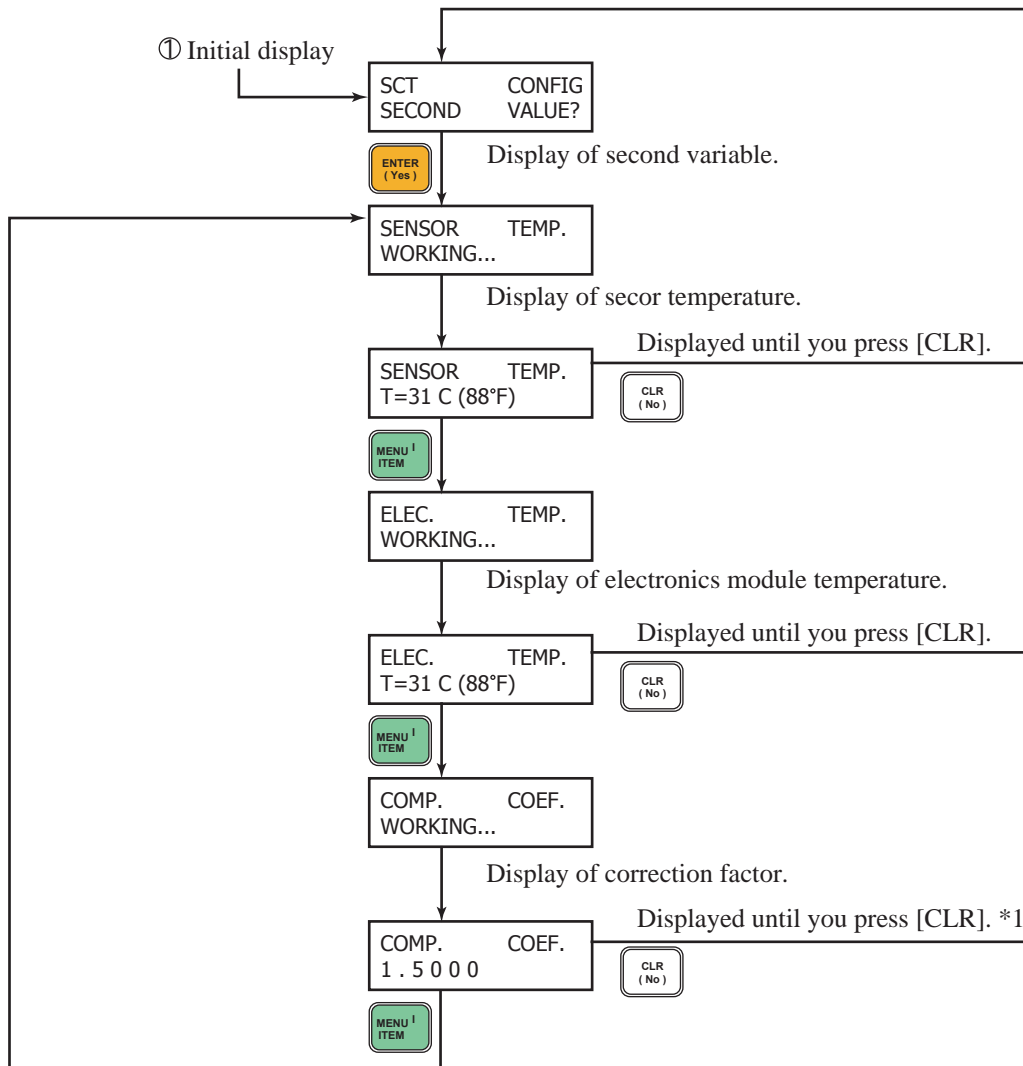

*1: Data is refreshed every 6 seconds.

② Display of PROM number

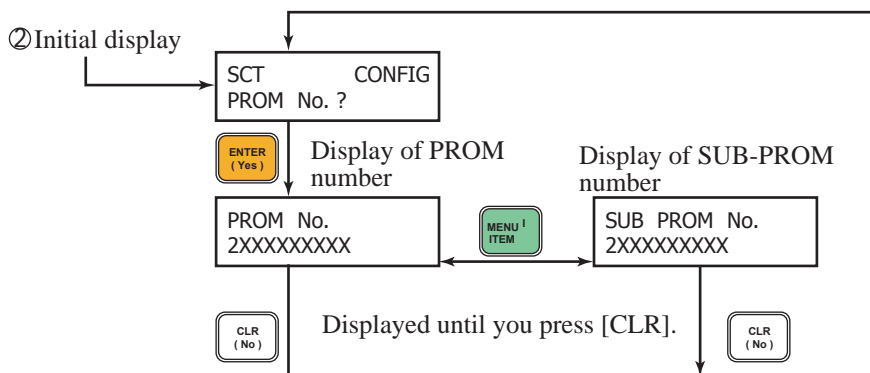



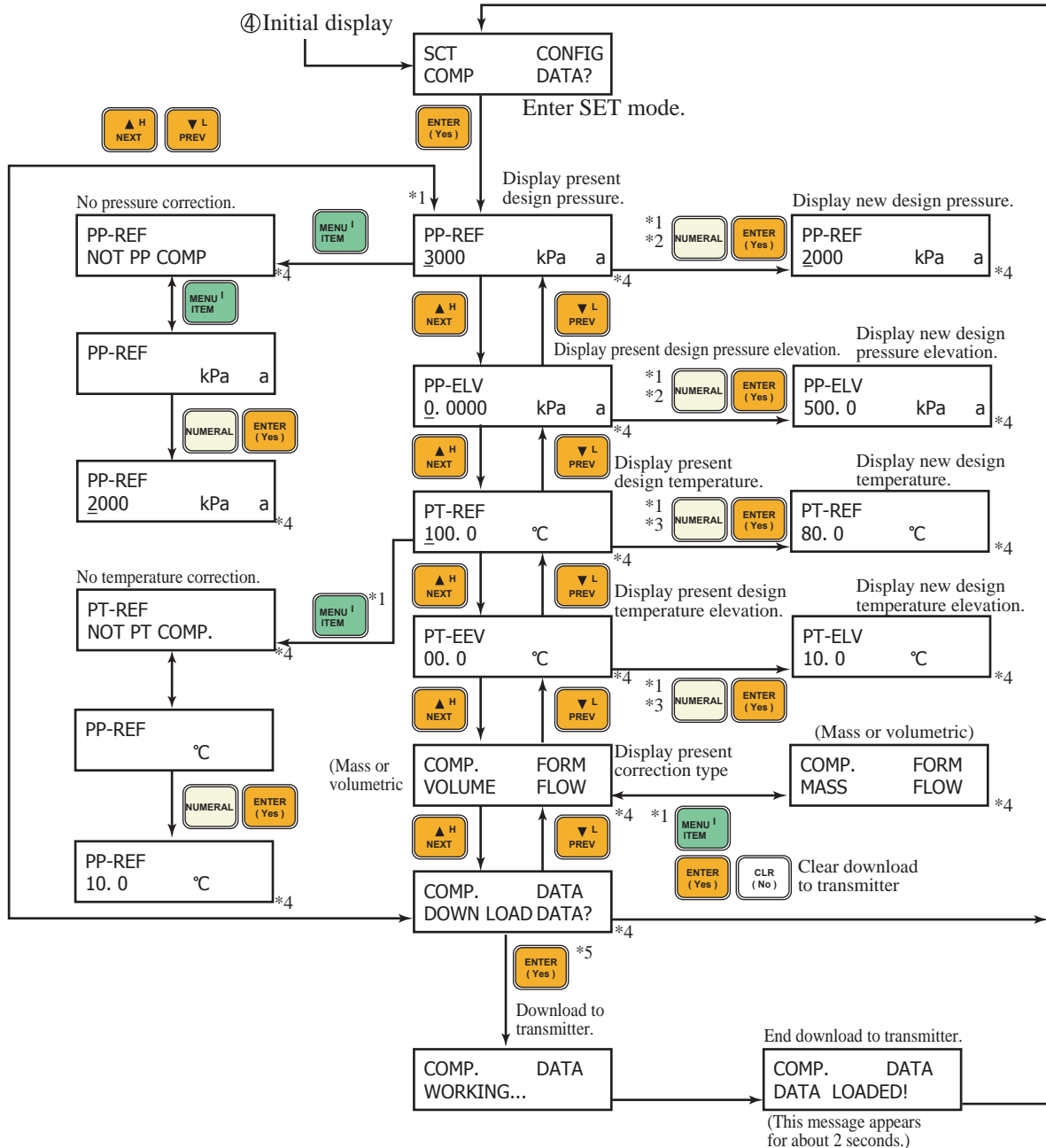

④ Setting of correction type, design pressure and temperature

~Note Setting can only be performed in some modes. Refer to “Figure 3-3 Flow-chart of configuration data entry”.



- *1: Effective only when in the MEASURE or INPUT mode.
- *2: Effective only for values greater than 0 kPa {kgf/cm²} abs.
- *3: Effective only for values greater than 0 K.

*4: Select the required play with the  or the  key, and then press the  key. Data will be entered and the message  will appear for about 2 seconds.

Finally, execute the procedure of *5 and download the setting data of “design pressure and temperature” to the transmitter.

- *5: Setting or modification is done as data is downloaded to transmitter.

⑤ Setting of temperature sensor type

~Note Setting is only possible in some modes. Refer to “Figure 3-3 Flow-chart of configuration data entry”.

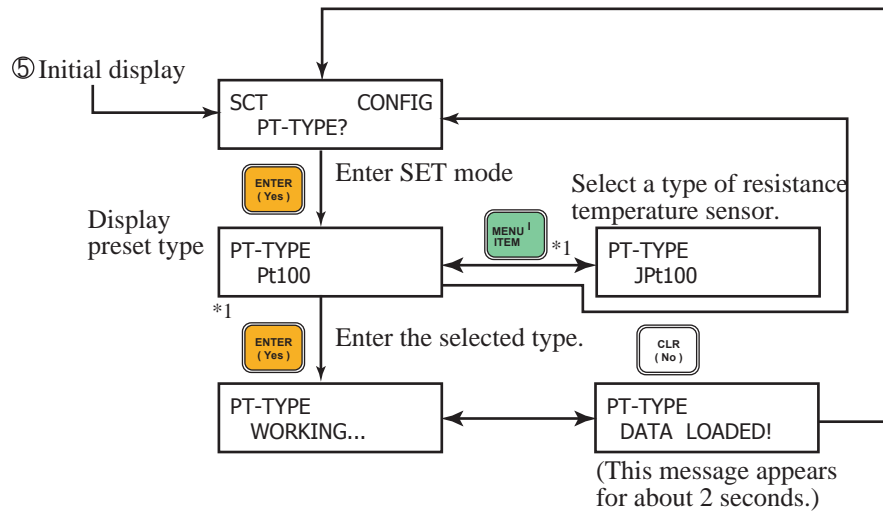

*1: Effective only when in MEASURE, INPUT or PT modes or when in DE output mode and temperature is being output.

⑥ Setting a combination of engineering units

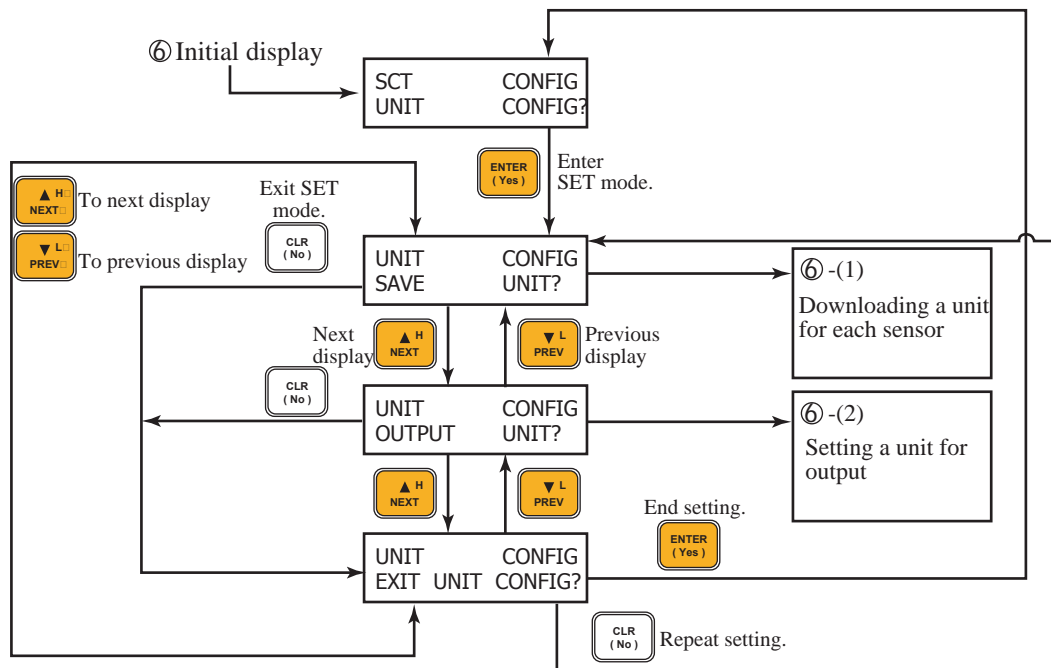

⑥-(1) Downloading a unit for each sensor

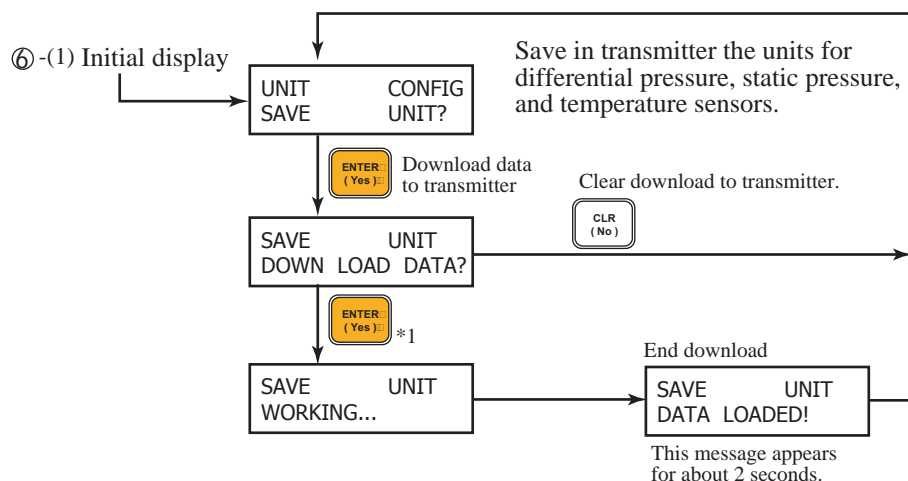

*1: The user-defined units are only for display of data on the SFC. They cannot be downloaded. See Item (5).

⑥-(2) Setting an engineering unit for output

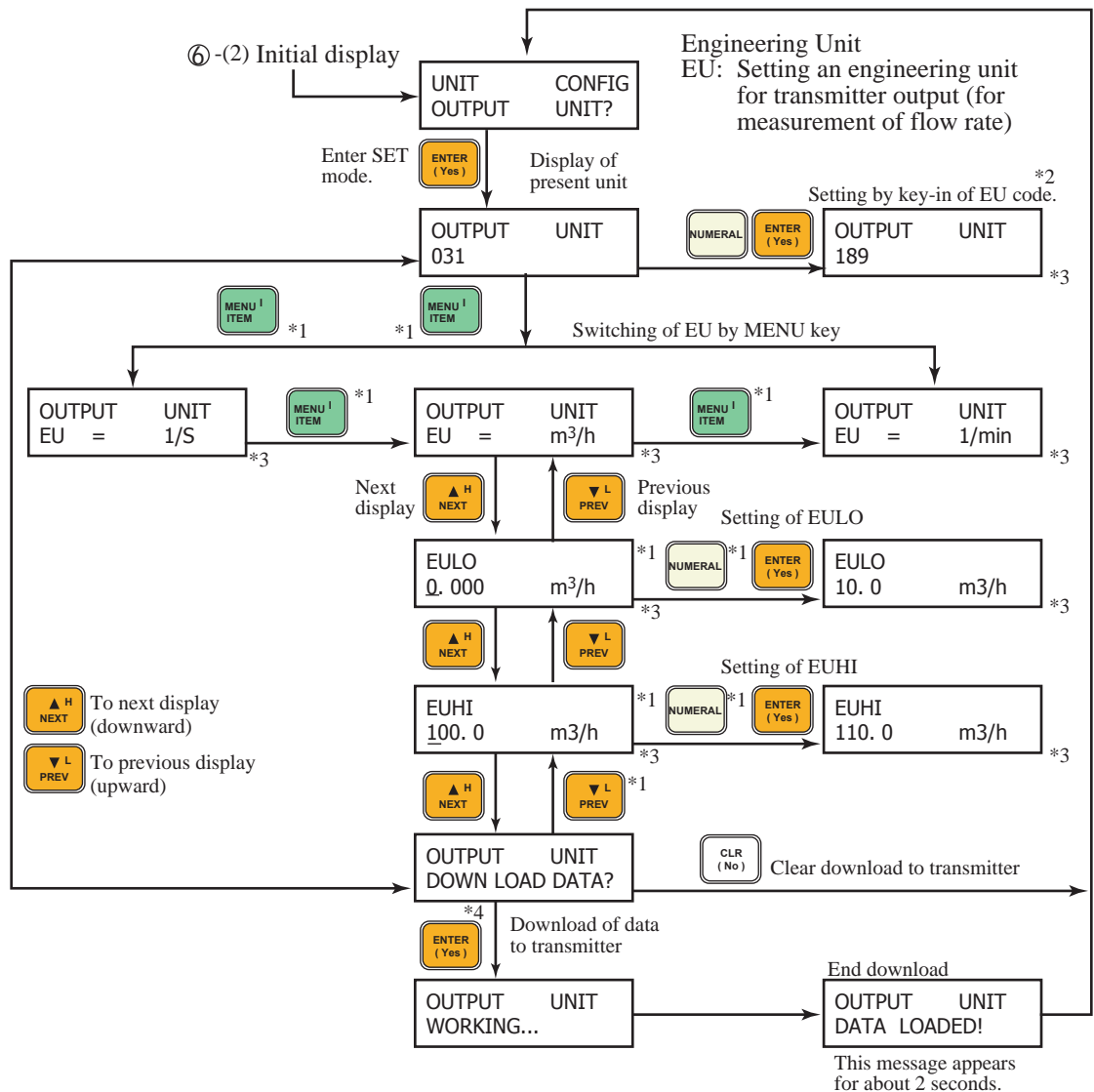

*1: Effective only when in MEASURE or INPUT mode.

*2: For EU codes, see Table 3-5.

*3: Select the required display with the  or  key, then press the  key.

Data will be entered, and the message  will appear for about 2 seconds.

Finally, execute *4 and download the “engineering unit for output” setting data to the transmitter.

*4: Setting or modification is done as data is downloaded to the transmitter.

Table 3-5 EU codes

Code	Unit	Code	Unit
030	gal/s	075	BPD
031	l/s	076	gal/d
032	Ft ³ /s	077	kgal/d
033	m ³ /s	181	g/s
041	Ft ³ /m	182	g/m
042	gal/m	183	g/h
043	l/m	184	kg/s
044	IGPM	185	kg/m
045	m ³ /m	186	kg/h
046	cc/m	187	kg/d
051	m ³ /h	188	MetT/m
052	ImpG/h	189	MetT/h
053	cc/h	190	MetT/d
054	l/h	191	lb/s
055	gal/h	192	lb/m
070	MilG/d	193	lb/h
071	MilL/d	194	lb/d
072	Ft ³ /d	195	ShTon/m
073	m ³ /d	196	ShTon/h
074	ImpG/d	197	Sh/Ton/d

⑦ Setting for optional items (for future expansion)

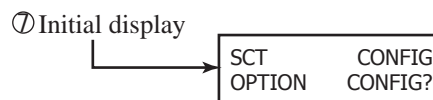

~Note *Optional items are yet to be defined.*

⑧ Data SAVE/RESTORE between the transmitter and SFC

~Note Setting can only be performed in some modes. Refer to “Figure 3-3 Flowchart of configuration data entry”.

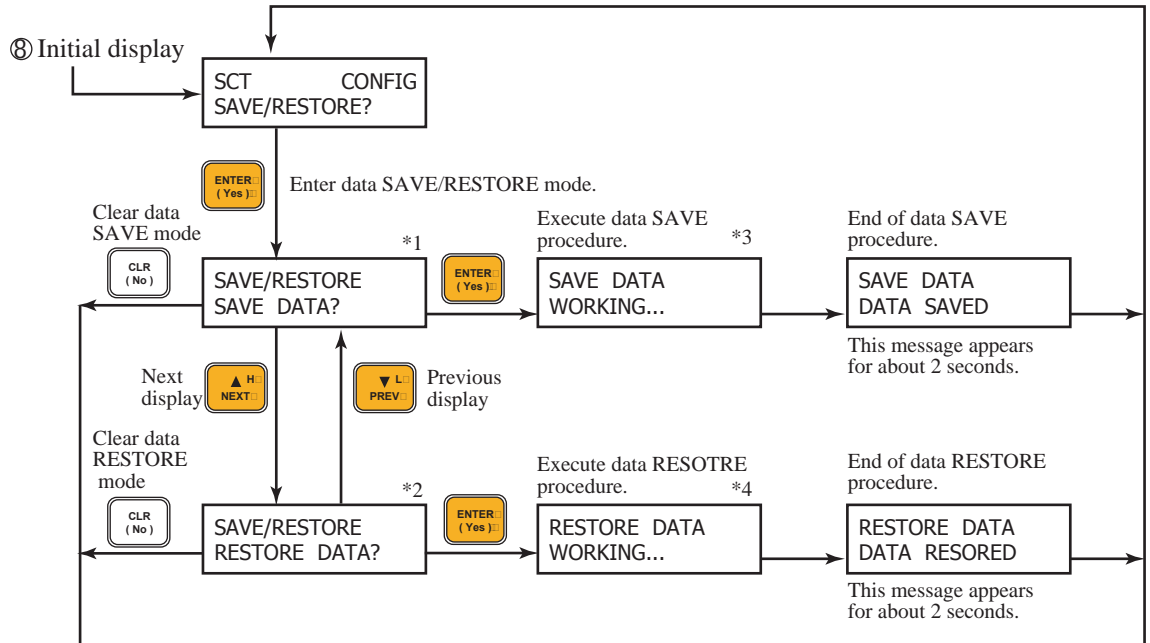

- *1: The term SAVE is used here to mean movement of configuration data from transmitter’s memory to SFC’s memory and its storage in the SFC.
- *2: The term RESTORE is used here to mean loading of saved data from the SFC’s memory to the transmitter’s memory.
- *3: Communication time
 When in analog output mode: Approx. 35 sec.
 When in digital output mode: Approx. 95 sec.
- *4: Communication time
 When in analog output mode: Approx. 35sec.
 When in digital output mode: Approx. 25 sec.

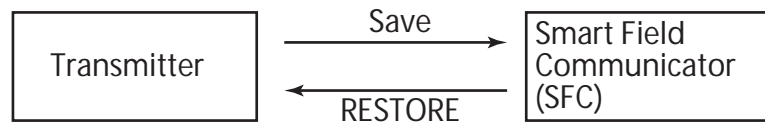





You may use this function for efficient configuration copying when you want to set up a number of transmitters with the same configuration.

⑨ To enter/exit CALIBRATION mode

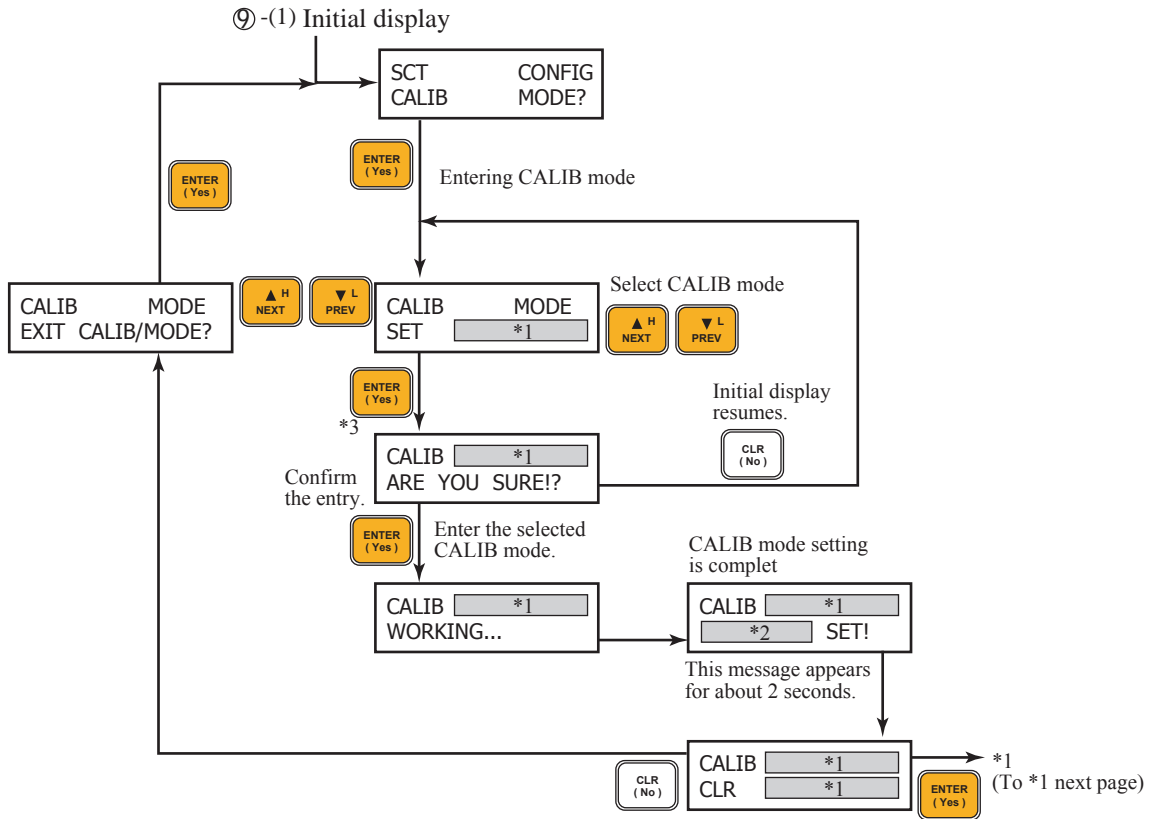
(For detail of calibration, refer to “Chapter 4 : Calibrating the Transmitter”.)

⑨-(1) To enter CALIBRATION mode



- *1: To select a CALIBRATION mode (DP, PP or PT mode), use the  and  keys.
- *2: The mode selected by *1 will be displayed.
- *3: When you the  key after selecting a CALIBRATION mode, the prompt will request you to confirm the entry once more.

⑨-(2) To exit CALIBRATION mode

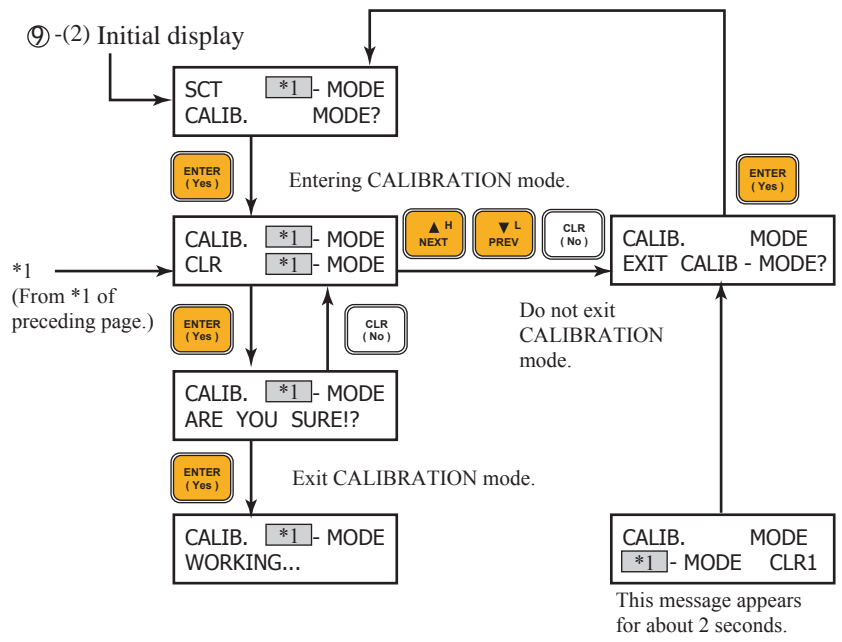



*1: The mode (DD, PP or PT) that was set in ⑨-(1) will be displayed.

⑩ To enter/exit INPUT mode (for simulated input)

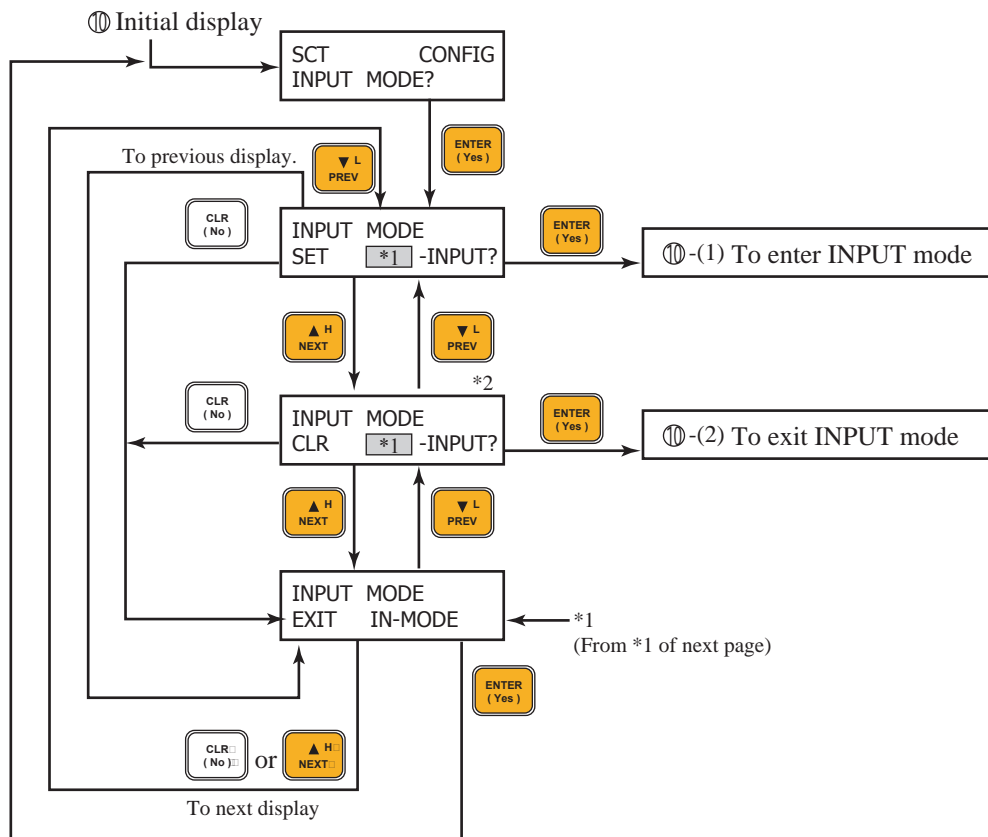
~Note Setting can be done or cannot be done depending on the mode. Refer to “Figure 3-3 Flowchart of configuration data entry”.



*1: Select DP-INPUT, PP-INPUT or PT-INPUT mode with the  and  keys.

*2: Appears when one of the above three input modes is set.

⑩-(1) To enter INPUT mode

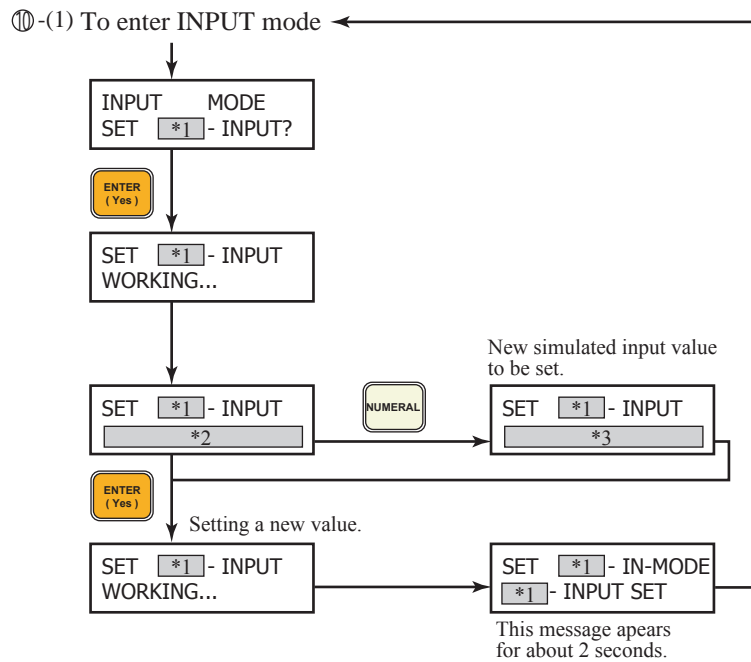

*1: Displays DP, PP or PT

*2: Displays the present input value. If a simulated value has already been entered, the value is displayed. Examples are shown below.

in DP-INPUT mode: 5.0 kPa {500.0 mm H₂O} d

in PP-INPUT mode: 1000 kPa {10.0 kgf/cm²} a

in PT-INPUT mode: 10.0°C (14°F)

The cursor is at the bottom of MSD of each numerical value. To modify the value, start modification by this column.

*3: The modified value is displayed.

⑩-(2) To exit INPUT mode

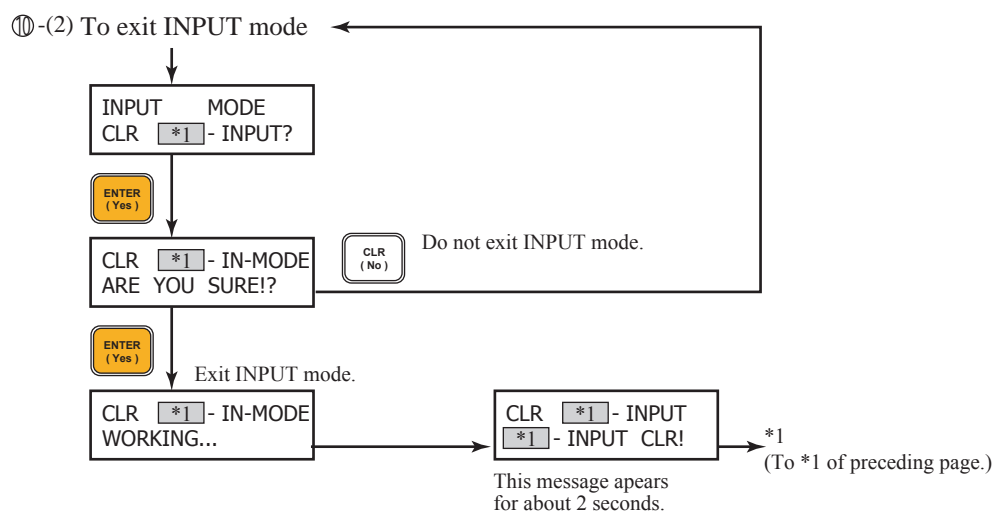

*1: The DP-, PP- or PT-INPUT mode that has already been set will appear.



Setting for DE

DE (Digital Enhancement) is a unique digital output signal system proposed by the Honeywell Group as a standard protocol for the international fieldbus standard.



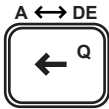

Selection of analog or DE output

Key	SFC display	Description
	<div style="border: 1px solid black; padding: 5px; margin-bottom: 10px;"> SCT TAG No. SQRT DP MAS-100 ↑① ↑② </div> <div style="border: 1px solid black; padding: 5px;"> DE XMTR TAG No. MAS-100 </div>	Analog output DE output ① LIN: Linear output SQRT: Square root output ② Tag No.

Change from analog output to DE output

Key	SFC display	Description
		
	<div style="border: 1px solid black; padding: 5px;"> SCT MAS-100 CHNG TO DIGITAL? </div>	Change to DE output?
	<div style="border: 1px solid black; padding: 5px;"> SCT MAS-100 ARE YOU SURE!?! </div>	Please confirm the change once more.
	<div style="border: 1px solid black; padding: 5px;"> SCT DE MAS-100 DE XMTR </div>	Has been changed to DE output.

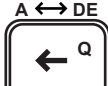
Change from DE output to analog output

Key	SFC display	Description
		*1: Not necessary if these keys have already been pressed.
<p>DE READ</p> 		
<p>* 1</p>		
		
<p>A ↔ DE</p> 	<div style="border: 1px solid black; padding: 5px; text-align: center;"> SCT DE MAS-100 CHNG TO ANALOG? </div>	Change to analog output?
<p>NON-VOL</p> 	<div style="border: 1px solid black; padding: 5px; text-align: center;"> SCT DE MAS-100 ARE YOU SURE!? </div>	Please confirm the change once more.
<p>NON-VOL</p> 	<div style="border: 1px solid black; padding: 5px; text-align: center;"> SCT MAS-100 ANALOG XMTR </div>	Has been changed to analog output.

(4) Configuration specifically for DE output

Press the  and  keys.

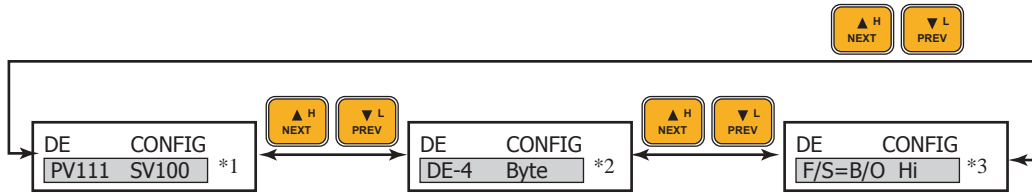

*1 As you press the  key,

- Dual Range
- Single Range
- Single Rng w/SV



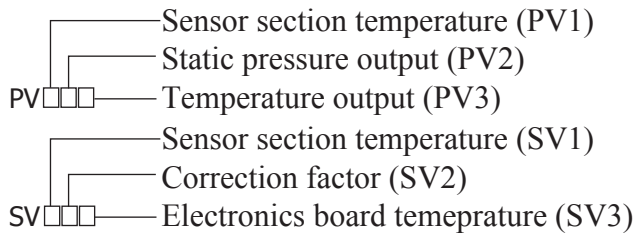

will be displayed in this order.

For the pressure-corrected differential pressure transmitter, select this:



- 0: Not delivered
- 1: Delivered

To enter "0" or "1", select it with the  and  keys and then press the  key.

Initial value is 

*2 As you press the  key,

- DE-4 Byte
- DE-6 Byte

*3 As you press the  key,

- F/S=B/O Hi
- F/S=LKG
- F/S=FSC, B/O Lo
- F/S=FSO, B/O Hi
- F/S=FSO, LKG
- F/S=FSO, B/O Lo

will be displayed in this order.

*2 and *3 must be set when the instrument is connected to a TDC System. For details, refer to "Manual for STDCM" IB2-2800-0400.

When the instrument is connected to an SPC, *2 is "DE-4 Byte"; setting of *3 is not related to this.

3-2: Verifying the span

Display and verify the span (URV-LRV) as follows:

*1: Select DP-, PP- or PT-SPAN display with the  key.

*2: Span will be displayed as follows, for example:

DP-SPAN: 50.0 kPa {5000.0 mmH₂O} d

PP-SPAN: 2000 kPa {20.0 kg/cm²} g

PT-SPAN: 50.0°C

*3: DP span will appear if you pressed the  key

or if differential pressure data has been displayed.

PP span will appear if static pressure data has been displayed.

PT span will appear if temperature data has been displayed.

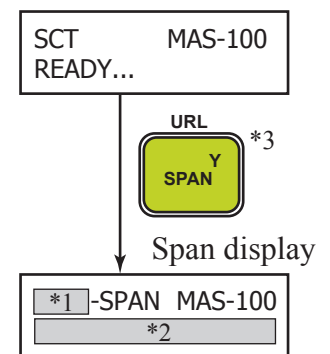



3-3: Verifying the maximum range

Display and verify the range (maximum setting range of each sensor) as follows:

*1: Select DP, PP or PT range display with the



key.

*2: Press the  and  keys in succession.

*3: Range will be displayed.

DP-URL: 100 kPa {10160 mmH₂O} d

PP-URL: 3.346 MPa {34.12 kg/cm²} g or 3.448 MPa {35.16 kg/cm²} a

PT-URL: 650°C (1202°F)

[The currently guaranteed range limit is 300°C (582°F)]

*4: DP range will appear if you press the  key or if differential pressure data has been displayed.

PP range will appear if static pressure data has been displayed.

PT range will appear if temperature data has been displayed.

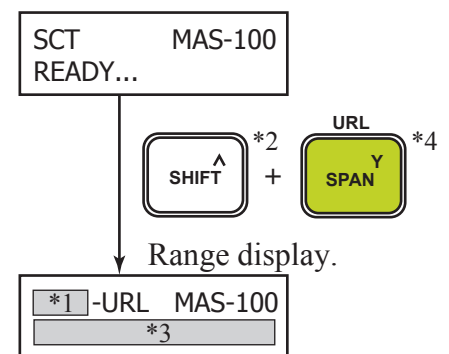

3-4: Verifying the input (Input Value of Each Sensor)

Display and verify the value measured by each sensor (DP, PP or PT sensor) in an engineering unit of measure as follows:

*1: Select DP, PP or PT range display with the



key.

*2: Press the  and  keys in succession.

*3: Range will be displayed as follows, for example.

DP: 1.059 kPa {108.0 mmH₂O} d

PP: 2.383 MPa {24.3 kg/cm²} g

PT: 51.3°C

*4: DP input value will appear if you press the  key or if differential pressure data has been displayed.

PP input value will appear if static pressure data has been displayed.

PT input value will appear if temperature data has been displayed.

*5: If you do not further operation, the displayed data will be refreshed approximately every 6 seconds.

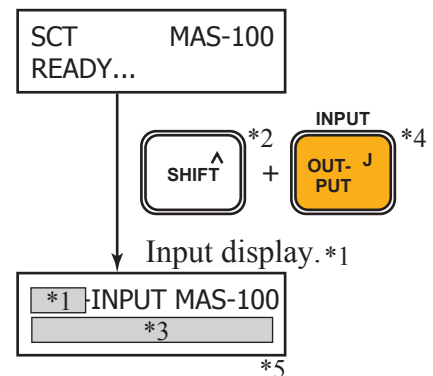

3-5: Verifying the output (Display of output in percentage)

Display and verify the output of each sensor (DP, PP, or PT sensor) in percentage with respect to the span (or in an engineering unit of measure for flow as defined in “oSetting a combination of engineering units” on page 3-24, as follows:)

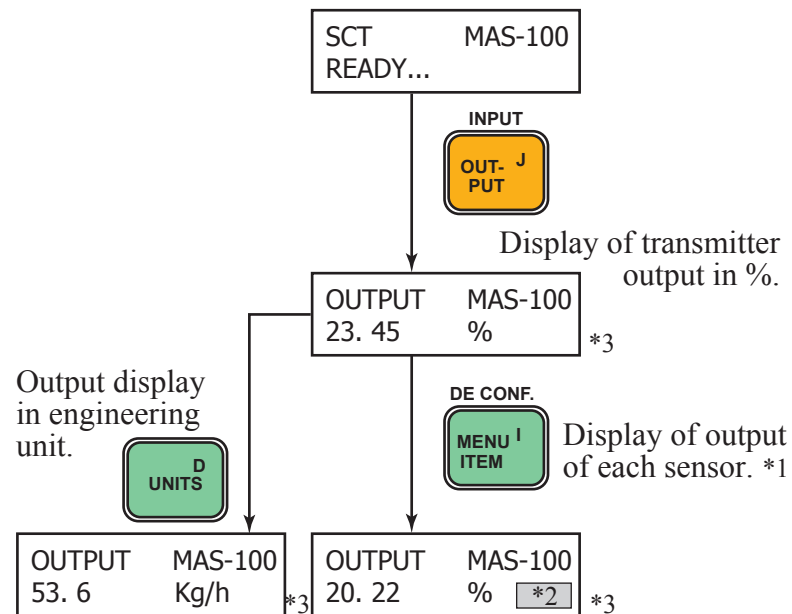

*1: Select DP, PP or PT output with the  key [provided that the instrument is in DE output mode and static pressure or temperature data is being delivered].

*2: As you press the  key, the display will cycle through PP to PT to SPACE (differential pressure) [provided that the instrument is in the DE output mode and static pressure or temperature data is being delivered].

*3: If you do not notihing else, the displayed data will be refreshed approximately every 6 seconds.

3-6: To enter or clear OUTPUT mode

OUTPUT mode allows you to use the transmitter as a constant-current source. You must use it in this mode for test purposes such as loop checks. To enter or clear OUTPUT mode, proceed as described below.

- ~Note 1. When the transmitter is in OUTPUT mode, it cannot be used for measurement.
- ~Note 2. When in OUTPUT mode, the transmitter delivers a constant current that is set and displayed as a percentage.

3-6-1: To enter OUTPUT mode

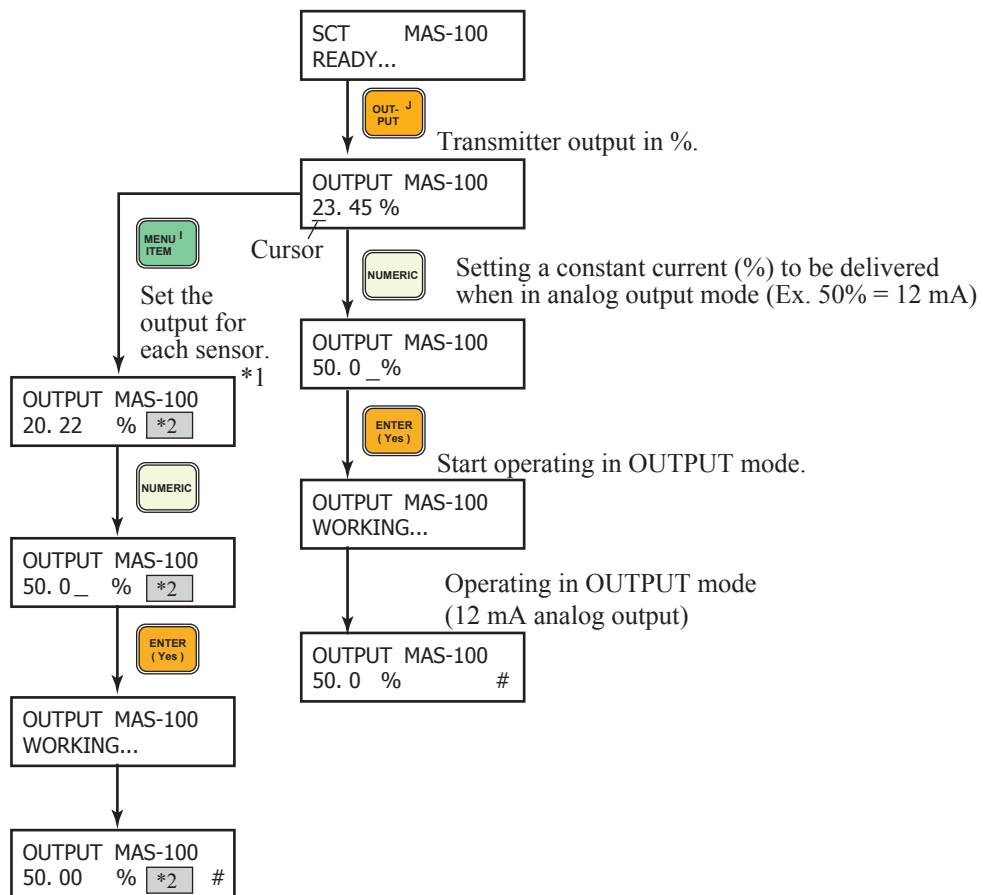



*1: Select DP, PP or PT output with the  key [provided that the instrument is in DE output mode and static pressure or temperature data is being delivered].

*2: As you press the  key, the display will cycle through PP to PT to SPACE (differential pressure).

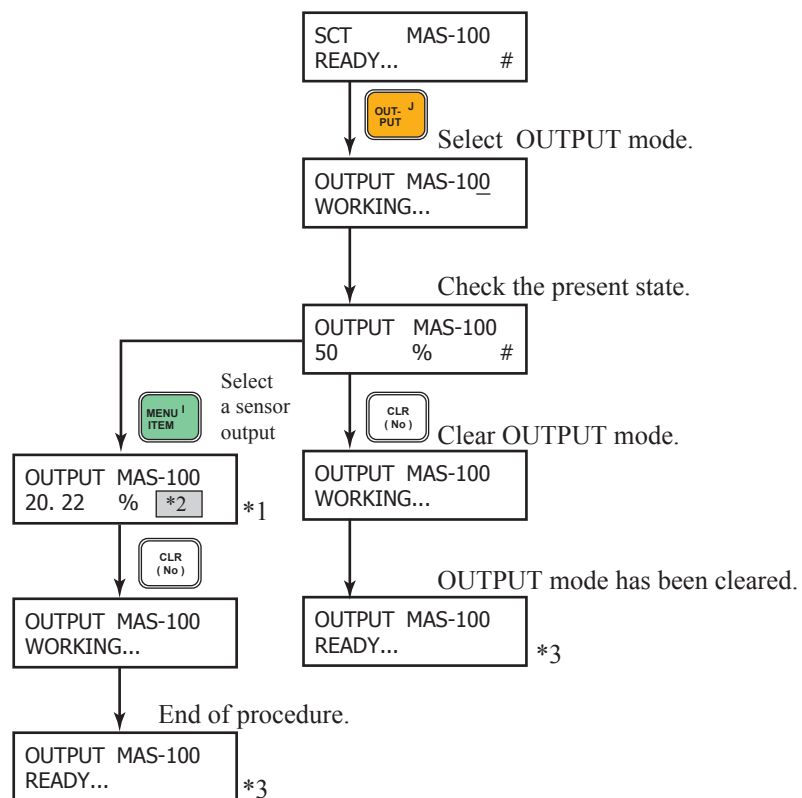
3-6-2: To clear OUTPUT mode





*1: Select DP, PP or PT output with the  key.

*2: As you press the  key, the display will cycle through PP to PT to SPACE (differential pressure).

*3: If two or more out puts have been set to the OUTPUT mode, clear each of them from the OUTPUT mode.

3-7: Verifying burnout direction

Verifying the direction of burnout protection as follows.

- *1: Press the  and  keys in succession.
- *2: Depending on the transmitter's hardware setting, one of the following will be displayed.
 DOWNSCALE (lower limit)
 UPSCALE (upper limit)
 NON-B/O (no burnout protective action)

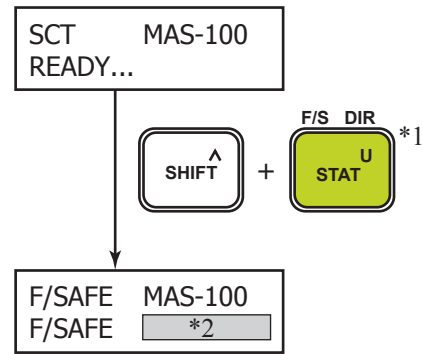

3-8: Verifying software version

Verify the software version of the transmitter and SFC as follows.

- *1: Press the  and  keys in succession.

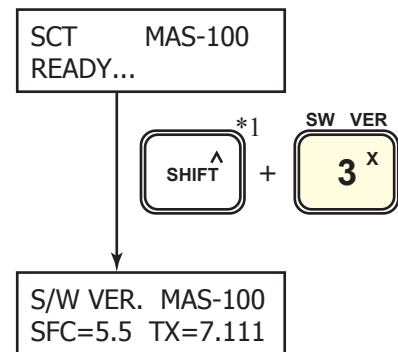

3-9: Checing and correcting date and time (model SFC260 only)

Checing date and time and correct them as required.

- Checking data and time

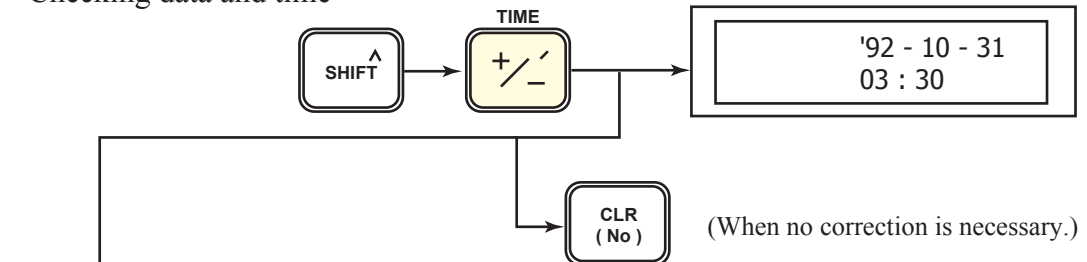

- Correcting date and time

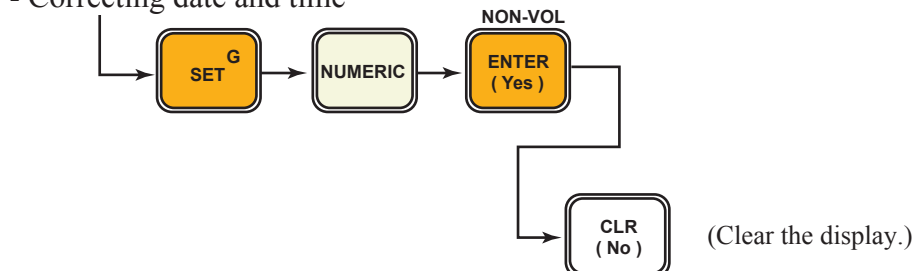

3-10:Scratchpads (Memos)

You can write memo information on the scratchpads (memos) of the transmitter as follows.

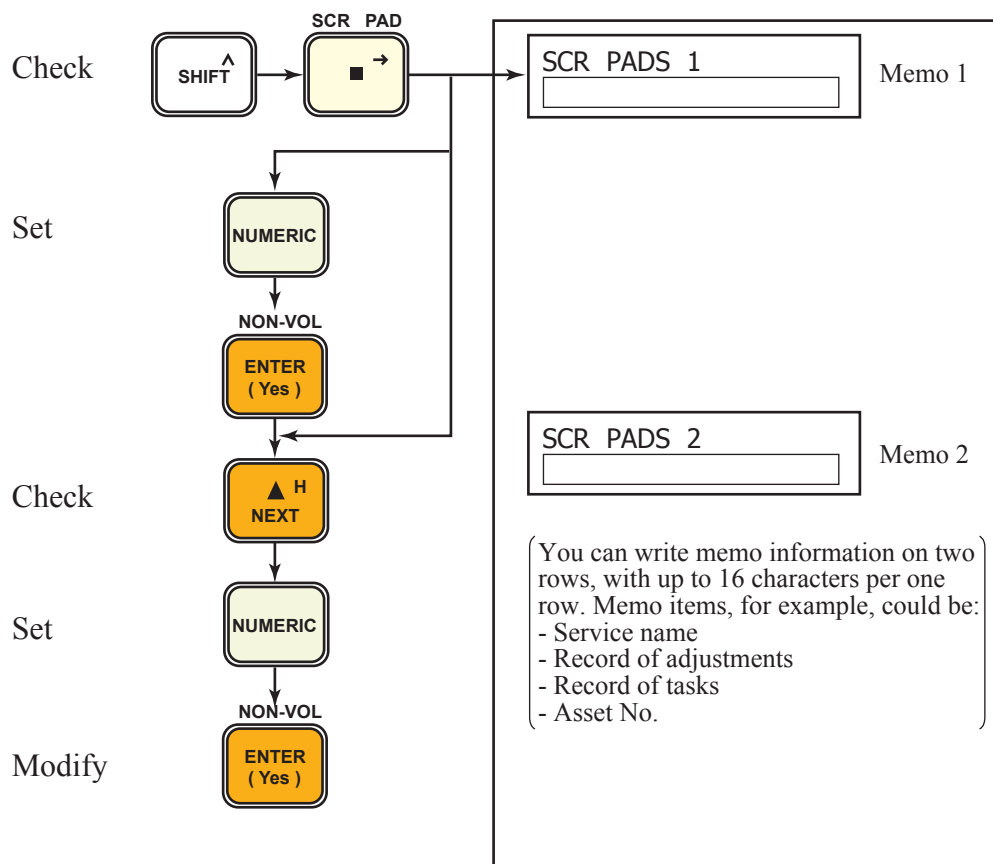

3-11:Printout of configuration data (model SFC260 only)

To print out configuration data (date, time, tag number, damping time constant, span,

etc.), press the  and  key in succession.

Example of printout

91-11-25 01:23	Date and time
TAG NO. TEST	Tag number
TYPE : DIF. PRESSURE	Type of transmitter
ANA/DE : ANALOG XMTR	Type of output signal
FORM : SQUARE ROOT	Type of output
LOFCUT : ZERO < 20.0%	Low flow cutoff value
: MODE = DEFAULT	Flow mode
MASS FLOW	Type of correction
PROM# : 2012977107	Serial number
SW VER : 7.010	S/W version
DAMP : 0.0 SECONDS	Damping time constant
SPAN : 50 kPa d	Span (differential pressure)
LRV : 0.000 kPa d	LRV (differential pressure)
URV : 50 kPa d	URV (differential pressure)
PP-REF : 1600 kPa g	Design pressure *1
PP-ELV : 0.3 kPa	Static pressure elevation
PT-REF : 100.0°C	Design temperature *2
PT-ELV : 0.003°C	Temperature elevation
EULO : 0.000 m ³ /h	EULO (Engineering Unit Low), unit of output, low limit
EUHI : 100.0 m ³ /h	EUHI (Engineering Unit High), unit of output, high limit
F/SAFE : UPSCALE	Direction of burnout protection
OUTPUT : 37.16%	Output
COMP : 0.6905	Correction factor
SENSOR : T=31°C (88°F)	Temperature of transmitter sensor section
DIFFERENTIAL PRESSURE	Differential pressure sensor
URL : 100 kPa d	URL (Upper Range Limit = available maximum range limit)
INPUT : 10 kPa d	INPUT
PROCESS PRESSURE	Pressure sensor
URL : 3.346 MPa g	URL (Upper Range Limit)
SPAN : 2000 kPa	Calibration span
LRV : 0.000 kPa g	Calibration LRV
URV : 2000 kPa g	Calibration URV
INPUT : 1000 kPa g	INPUT
PROCESS TEMPERATURE	Temperature sensor
SUB# : 2002977107	Serial number
URL : 650.0°C	URL (Upper Range Limit)
LRL : -200.0°C	LRL (Lower Range Limit = available minimum range limit)
SPAN : 130.0°C	Calibration span
LRV : 0.000°C	Calibration LRV
URV : 130.0°C	Calibration URV
INPUT : 80.0°C (88°F)	Temperature of electronics board section
ELEC. T=31°C (88°F)	Electronics board temperature
STATUS	Status
STATUS CHECK = OK	*3

*1: When 0 kPa {0 kgf/cm²}abs., “NOT PP COMP” is printed out.

*2: When 0 K, “NOT PT COMP” is printed out.

*3: Communication time

When in analog output mode:	Approx. 40 sec.
When in digital output mode:	Approx. 20 sec.
Printed out time	Approx. 55 sec.

3-12:Print of SFC display (Action print) (model SFC260 only)

The display is printed out each time it is changed by key operations. Thus, you can keep a record of task executed.

Action print

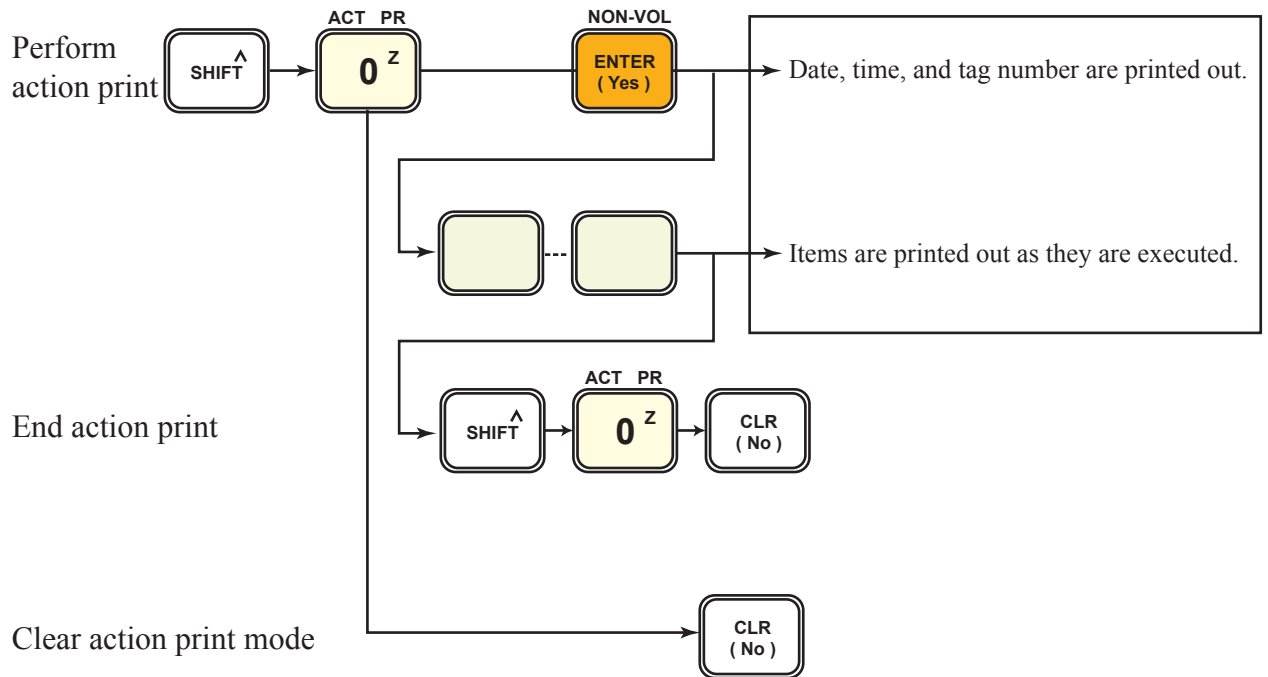

3-13:Feeding rolled paper (model SFC260 only)

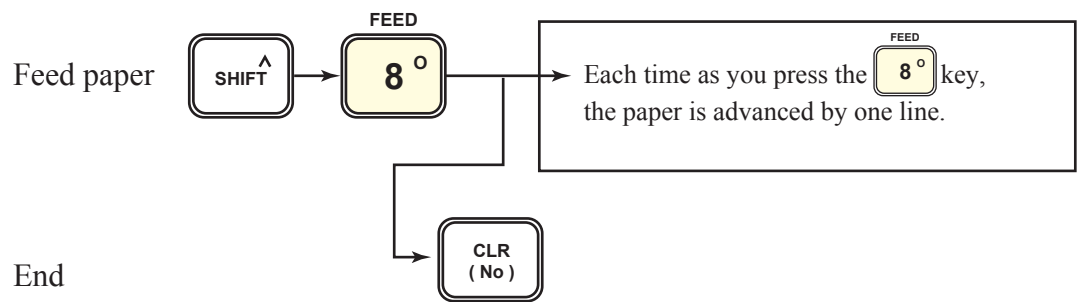

Chapter 4 : Calibrating the Transmitter

You can use the SFC to calibrate the transmitter. This section describes the calibrated items and calibration procedures.

- ~Note**
1. *For best measurement accuracy, we recommend that you calibrate the transmitter for the actual measurement range that will be used to control the process.*
 2. *Be sure to allow the transmitter to stabilize operation for approximately 30 minutes before starting calibration.*

4-1: Setting up transmitter for calibration

- (a) Equipment needed:
- Precision pressure source with accuracy 0.004% full scale or better.
 - Voltmeter with accuracy 0.03% full scale or better (including the accuracy of the resistor used for current measurements made by voltage drop)
 - SFC
- (b) Making connections and testing communications
- Check that proper communication is established between SFC and transmitter.
- (c) This transmitter has no terminals for output current measurement with an external milliammeter. Read the output by means of the SFC or a voltmeter.

4-2: Operation modes and calibrated items

The model JTD720 Transmitter can operate in six modes: measurement (MEASURE) mode, differential process pressure (DP) mode, static process pressure (PP) mode, process temperature (PT) mode, simulated INPUT mode, and OUTPUT mode. The functions of these modes of operation are as shown in Table 4-1.

Table 4-1 Modes and functions

Mode	Function
MEASURE mode	The transmitter delivers a pressure-corrected output. Normally, it is used in this mode.
DP mode	This mode is for calibration of the differential pressure sensor.
PP mode	This mode is for calibration of the static pressure sensor.
PT mode	This mode is for calibration of the temperature sensor.
INPUT mode	By applying a simulated differential pressure or static pressure, a pressure-corrected output of the transmitter can be read.
OUTPUT mode	This mode is for calibration of the constant current source or the D/A converter.

Table 4-2 Calibration items in respective modes

The items that can be calibrated (indicated by ○) or cannot be calibrated (indicated by ×) are shown in this table.

	Mode					
	MEASURE	DP	PP	PT	INPUT	OUTPUT
Differential pressure 0 kPa {0 mmH ₂ O}d	○	○	×	×	×	×
LRV	×	○	×	×	×	×
URV	×	○	×	×	×	×
Initialization of differential pressure calibration value	×	○	×	×	×	×
Static pressure 101.3 kPa {1.033 kgf/cm ² } abs	○	×	○	×	×	×
Static pressure LRV	×	×	○	×	×	×
Static pressure URV	×	×	○	×	×	×
Initialization of static pressure calibration value	×	×	○	×	×	×
Temperature LRV	×	×	×	○	×	×
Temperature URV	×	×	×	○	×	×
Initialization of temperature calibration value	×	×	×	○	×	×
D/A 0%	×	×	×	×	×	○ Note 3
D/A 100%	×	×	×	×	×	○ Note 3

~Note 1. Available when PV2 (PP) is delivered with Multi-variable DE and not in the OUTPUT mode for PV2.

~Note 2. Available when PV3 (PT) is delivered with Multi-variable DE and not in the OUTPUT mode for PV3.

~Note 3. Available for analog output only.

4-3: Calibrating output signal

You calibrate the output circuit (D/A converter) at its 0% and 100% levels by operating the transmitter in OUTPUT mode.

4-3-1: Calibrating output signal at 0%

Key in 0%

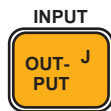

O	U	T	P	U	T		M	A	S	-	1	0	0	
W	O	R	K	I	N	G	.	.	.					

O	U	T	P	U	T		M	A	S	-	1	0	0	
0	.	0	0				%							

Present output signal level in (%) appears.



O	U	T	P	U	T		M	A	S	-	1	0	0	
0	_						%							

Key in "0".



O	U	T	P	U	T		M	A	S	-	1	0	0	
W	O	R	K	I	N	G	.	.	.					

O	U	T	P	U	T		M	A	S	-	1	0	0	
0	.	0	0				%						#	

Put transmitter in constant-current source mode and set output to 0%.

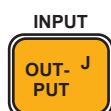

O	U	T	P	U	T		M	A	S	-	1	0	0	
W	O	R	K	I	N	G	.	.	.					

O	U	T	P	U	T		M	A	S	-	1	0	0	
0	.	0	0				%						#	

Present output to 0%.

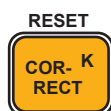

O	U	T	P	U	T		M	A	S	-	1	0	0	
C	O	R	R	E	C	T	D	A	C	Z	E	R	#	

As you press the CORRECT key, the output current is calibrated to 0%.

If reading is lower than 4 mA or 1 V (with shut resistor 250 Ω), go to next step.



O	U	T	P	U	T		M	A	S	-	1	0	0	
W	O	R	K	I	N	G	.	.	.					

Gradually increase output to 4 mA or 1V reading

O	U	T	P	U	T		M	A	S	-	1	0	0	
I	N	C	R	E	A	S	E	D	4	m	A		#	

If reading is higher than 4 mA or 1 V (with shut resistor 250 Ω), go to the next step.



O	U	T	P	U	T		M	A	S	-	1	0	0	
W	O	R	K	I	N	G	.	.	.					

Gradually decrease output to 4 mA or 1V reading

O	U	T	P	U	T		M	A	S	-	1	0	0	
D	E	C	R	E	A	S	E	D	4	m	A		#	

4-3-2: Calibrating output signal at 100%

Key-in 100%

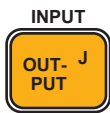

O	U	T	P	U	T			M	A	S	-	1	0	0	
W	O	R	K	I	N	G	.	.	.						

O	U	T	P	U	T			M	A	S	-	1	0	0	
0	.	0	0					%							#

Present output signal level in percentage appears 0 (zero).



O	U	T	P	U	T			M	A	S	-	1	0	0	
1	_							%							

Key in 100 as desired output level percentage.



O	U	T	P	U	T			M	A	S	-	1	0	0	
1	0	_						%							



O	U	T	P	U	T			M	A	S	-	1	0	0	
1	0	0	_					%							



O	U	T	P	U	T			M	A	S	-	1	0	0	
W	O	R	K	I	N	G	.	.	.						

O	U	T	P	U	T			M	A	S	-	1	0	0	
1	0	0	.	0	0			%							#

Put transmitter into constant-current source mode and set output to 100%.

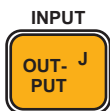

O	U	T	P	U	T			M	A	S	-	1	0	0	
W	O	R	K	I	N	G	.	.	.						

O	U	T	P	U	T			M	A	S	-	1	0	0	
1	0	0	.	0	0			%							#

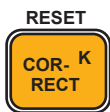

O	U	T	P	U	T			M	A	S	-	1	0	0	
C	O	R	R	E	C	T		D	A	C		Z	E	R	#

When you press the CORRECT key, the output current is calibrated to 100%.

If reading is lower than 20 mA or 5 V (with shut resistor 250 Ω), go to next step.



O	U	T	P	U	T			M	A	S	-	1	0	0	
W	O	R	K	I	N	G	.	.	.						

Gradually increase output to 20 mA or 5V reading

O	U	T	P	U	T			M	A	S	-	1	0	0		
I	N	C	R	E	A	S	E	D				2	0	m	A	#

If reading is higher than 20 mA or 5 V (with shut resistor 250 Ω), go to the next step.



O	U	T	P	U	T			M	A	S	-	1	0	0	
W	O	R	K	I	N	G	.	.	.						

Gradually decrease output to 20 mA or 5V reading

O	U	T	P	U	T			M	A	S	-	1	0	0		
D	E	C	R	E	A	S	E	D				2	0	m	A	#

4-3-3: Manually saving calibration data to Non-Volatile Memory (NVM)

Calibration data is stored in the transmitter’s working memory. The working memory automatically saves data to the transmitter’s Non-Volatile Memory (NVM) within 30 seconds of any change in work memory data. You can speed the NVM data save by manually initiating the save from the keyboard.

SHIFT ^					S	H	I	F	T	-				

NON-VOL ENTER (Yes)	S	C	T					M	A	S	-	1	0	0
		W	O	R	K	I	N	G	.	.	.			

Save data to transmitter’s Non-Volatile Memory (NVM). This takes approximately 8 seconds.

S	C	T						M	A	S	-	1	0	0
D	A	T	A	N	O	N	V	O	L	A	T	I	L	E

End of procedure

4-3-4: Quitting constant-current source mode

To exit from constant-current source mode, proceed as follows:

INPUT OUT-PUT J	O	U	T	P	U	T			M	A	S	-	1	0	0
		W	O	R	K	I	N	G	.	.	.				

O	U	T	P	U	T			M	A	S	-	1	0	0
	0	.	0	0			%							#

Present output signal level percentage apperas

CLR (No)	O	U	T	P	U	T			M	A	S	-	1	0	0
		W	O	R	K	I	N	G	.	.	.				

Exit constant-current source mode.

O	U	T	P	U	T			M	A	S	-	1	0	0
	R	E	A	D	Y	.	.	.						

End of procedure.

~Note *The symbol # disappears, indicating that the transmitter has exited constant-current source mode.*

4-4: Calibrating the differential pressure sensor

To calibrate the instrument as a differential pressure transmitter, set it in DP mode. (Refer to “4-2: Operation modes and calibrated items”.) However, you may use the MEASURE mode to calibrate the zero point in the equilibrium pressure state.

4-4-1: Calibrate zero point in equilibrium pressure state

For this calibration, set the transmitter to the equilibrium pressure state and then proceed as follows:

Calibration in MEASUREMODE



				S	H	I	F	T	-					

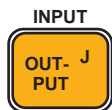

D	P	-	I	N	P	T		M	A	S	-	1	0	0
			W	O	R	K	I	N	G	.	.	.		

D	P	-	I	N	P	T		M	A	S	-	1	0	0
			0	.	0	0	5		k	P	a			d

Present differential pressure input (0.005 kPa in this example) appears.

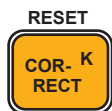

D	P	-	I	N	P	T		M	A	S	-	1	0	0
			Z	E	R	O		I	N	P	U	T	?	

Prompt asks if you want to enter the present input pressure as the zero point. Be sure that the input is in an equilibrium pressure state.



D	P	-	I	N	P	T		M	A	S	-	1	0	0
			A	R	E		Y	O	U		S	U	R	E

Prompt request you to confirm the entry once more.



D	P	-	I	N	P	T		M	A	S	-	1	0	0
			W	O	R	K	I	N	G	.	.	.		

D	P	-	I	N	P	T		M	A	S	-	1	0	0
			I	N	P	U		Z	E	R	O	E	D	



Zero point has been calibrated with present input pressure.

Calibration in DP mode

Set the transmitter to DP mode

NON-VOL

S	C	T					C	O	N	F	I	G		
S	E	C	O	N	D	.		V	A	L	U	E	?	

Press the  key 8 times or the  key thrice.

S	C	T					C	O	N	F	I	G		
C	A	L	I	B	.		M	O	D	E	?			

Prompt asks if you want to enter CALIBRATION mode.

NON-VOL



C	A	L	I	B	.		M	O	D	E				
S	E	T					D	P	-	M	O	D	E	?

Prompt asks if you want to enter DP mode.

NON-VOL

S	E	T					D	P	-	M	O	D	E	
A	R	E		Y	O	U		S	U	R	E	!	?	

Prompt requests you to confirm the entry once more.

[If you don't want to enter DP mode, press the  key.]

NON-VOL

S	E	T					D	P	-	M	O	D	E	
	W	O	R	K	I	N	G	.	.	.				

S	E	T					D	P	-	M	O	D	E	
D	P	-	M	O	D	E	S	E	T	!				

This message appears for about 2 seconds.

C	A	L	I	B	.		D	P	-	M	O	D	E	
C	L	R					D	P	-	M	O	D	E	?

Transmitter has entered DP mode. Prompt asks if you want to clear DP mode.

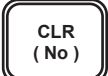

C	A	L	I	B	.		D	P	-	M	O	D	E		
E	X	I	T		C	A	L	I	B	-	M	O	D	E	?

Prompt asks if you want to exit CALIBRATION mode.

NON-VOL

S	C	T					D	P	-	M	O	D	E	
C	A	L	I	B	.		M	O	D	E	?			

Transmitter has exited CALIBRATION mode. (It has not cleared DP mode yet.)

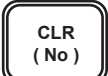

S	C	T					D	P	-	M	O	D	E	
E	X	I	T	?										

NON-VOL

S	C	T					D	P	-	M	O	D	E	
	R	E	A	D	Y	.	.	.						#

← Symbol # indicates that instrument is in DP mode.

Calibrating the zero point



				S	H	I	F	T	-					
														#

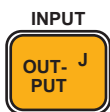

D	P	-	I	N	P	T		D	P	-	M	O	D	E	
	0	.	0	0	5			k	P	a				d	#

Present differential pressure input (0.005 kPa in this example) appears.



D	P	-	I	N	P	T		D	P	-	M	O	D	E	
		Z	E	R	O		I	N	P	U	T	?			#

Prompt asks if you want to enter the present input pressure as the zero point. Be sure that the input is in an equilibrium pressure state.



D	P	-	I	N	P	T		D	P	-	M	O	D	E	
	A	R	E		Y	O	U		S	U	R	E		!	?

Prompt requests you to confirm entry once more.





D	P	-	I	N	P	T		D	P	-	M	O	D	E	
	W	O	R	K	I	N	G	.	.	.					

D	P	-	I	N	P	T		D	P	-	M	O	D	E	
		I	N	P	U	T		Z	E	R	O	E	D		#

Zero point has been calibrated with present input pressure.

To exit the DP mode

	S	C	T					D	P	-	M	O	D	E	
	S	E	C	O	N	D	.		V	A	L	U	E	?	

Press the  key 7 times or the  key twice.

S	C	T						D	P	-	M	O	D	E	
C	A	L	I	B	.			M	O	D	E	?			

Prompt asks if you want to enter CALIBRATION mode.

	C	A	L	I	B	.					D	P	-	M	O	D	E	
	C	L	R								D	P	-	M	O	D	E	?

Prompt asks if you want to clear DP mode.

	C	L	R								D	P	-	M	O	D	E	
	A	R	E		Y	O	U				S	U	R	E		!	?	

Prompt asks you to confirm it once more.

	C	L	R								D	P	-	M	O	D	E	
		W	O	R	K	I	N	G	.	.	.							

C	L	R									D	P	-	M	O	D	E	
D	P	-	M	O	D	E		C	L	R								

DP mode has been cleared.

C	A	L	I	B	.						M	O	D	E				
E	X	I	T		C	A	L	I	B	-	M	O	D	E	?			

Prompt asks if you want to exit CALIBRATION mode

	S	C	T								C	O	N	F	I	G		
	C	A	L	I	B						M	O	D	E				

Transmitter has exited CALIBRATION mode.

4-4-2: Calibrating pressure range

You calibrate the pressure range of the transmitter by applying known zero and span pressures to set the LRV and URV settings, respectively, through the SFC. To calibrate the differential pressure range, you must set the transmitter to DP mode.



Setting LRV

Apply a reference input pressure for LRV to the transmitter and calibrate for that LRV using the SFC. If the reference input pressure and LRV do not conform, make them conform first.

~Note *Always calibrate the LRV first, even when the range is reversed.*

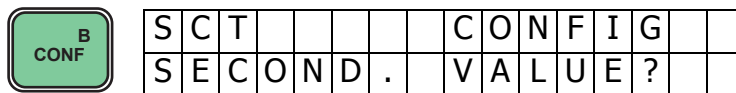
Set the transmitter to DP mode



Press the  key 8 times or the  key thrice.

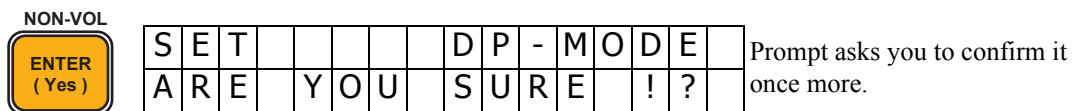
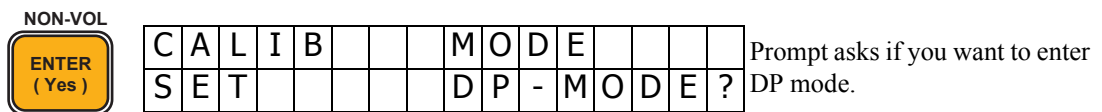
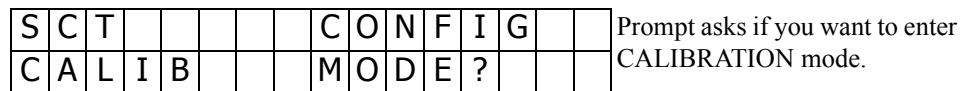

[If you don't want to enter DP mode, press the  key.]

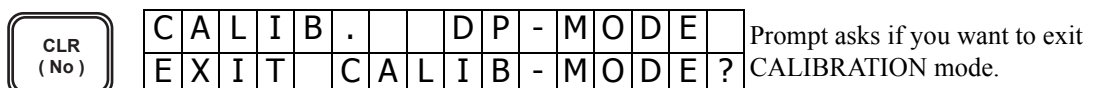
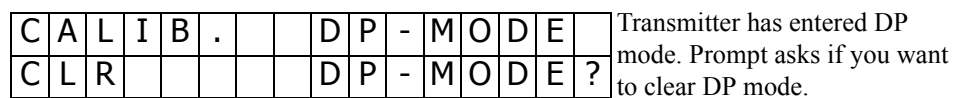
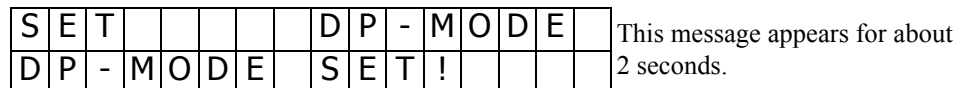
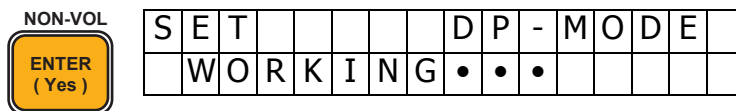

NON-VOL

S	C	T					D	P	-	M	O	D	E	
C	A	L	I	B	.		M	O	D	E	?			

 Transmitter has exited CALIBRATION mode. (It has not cleared DP mode yet.)

CLR

S	C	T					D	P	-	M	O	D	E	
E	X	I	T	?										

NON-VOL



S	C	T					D	P	-	M	O	D	E	
	R	E	A	D	Y	.	.	.						#

Calibrating the LRV

LRV E



D	P	-	L	R	V		D	P	-	M	O	D	E	
	0	.	0	0	0	0	k	P	a				d	#

 Pressure LRV setting stored in transmitter's memory appears.

RESET



D	P	-	L	R	V		D	P	-	M	O	D	E	
C	O	R	R	E	C	T	D	P	-	L	R	V	?	#

 Prompt asks if LRV is to be calibrated to the applied reference pressure. Make sure that the reference input pressure conforms with LRV

NON-VOL

D	P	-	L	R	V		D	P	-	M	O	D	E	
A	R	E		Y	O	U		S	U	R	E	!	?	

 Prompt requests you to confirm the entry once more.

NON-VOL

D	P	-	L	R	V		D	P	-	M	O	D	E	
	W	O	R	K	I	N	G	.	.	.				

 As you press [ENTER], the LRV is calibrated to the reference input pressure. This takes about 20 seconds.



D	P	-	L	R	V		D	P	-	M	O	D	E	
D	P	-	L	R	V		C	O	R	R	E	C	T	#

 End of calibration.

To exit the DP



S	C	T					C	O	N	F	I	G		
S	E	C	O	N	D	.	V	A	L	U	E	?		

Press the  key 7 times or the  key twice.

S	C	T					C	O	N	F	I	G		
C	A	L	I	B			M	O	D	E	?			

Prompt asks if you want to enter CALIBRATION mode.



C	A	L	I	B			M	O	D	E				
S	E	T					D	P	-	M	O	D	E	?

Prompt asks if you want to enter DP mode.



C	L	R					D	P	-	M	O	D	E	
A	R	E		Y	O	U		S	U	R	E	!	?	

Prompt requests you to confirm it once more.



C	L	R					D	P	-	M	O	D	E	
	W	O	R	K	I	N	G	.	.	.				

C	L	R					D	P	-	M	O	D	E	
D	P	-	M	O	D	E		C	L	R	!			

DP mode has been cleared.

C	A	L	I	B	.		M	O	D	E					
E	X	I	T		C	A	L	I	B	-	M	O	D	E	?

Prompt asks if you want to exit CALIBRATION mode.



S	C	T					C	O	N	F	I	G		
C	A	L	I	B			M	O	D	E	?			



Prompt asks if you want to enter CALIBRATION mode.

Setting URV

Apply to the transmitter a reference input pressure for URV and calibrate the transmitter for the URV through the SFC. If the reference input pressure and LRV do not conform, make them conform first.

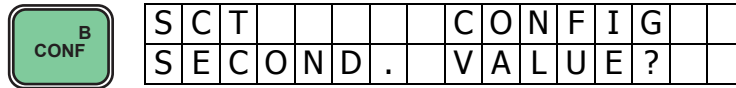
Set the transmitter to DP mode



Press the  key 8 times or the  key thrice.

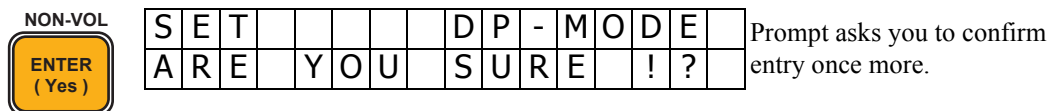
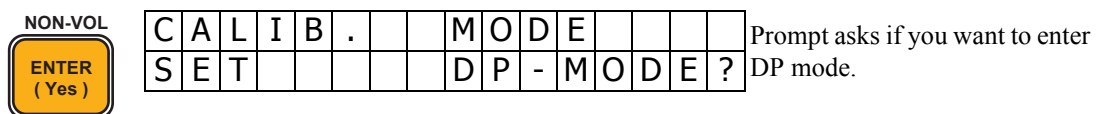
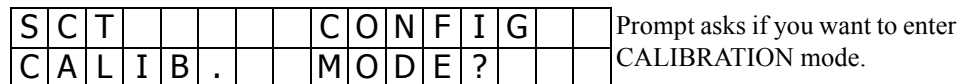

[If you don't want to enter DP mode, press the  key.]

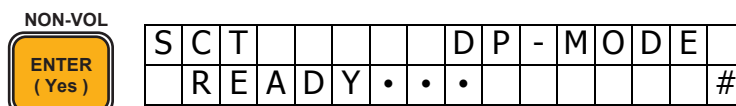
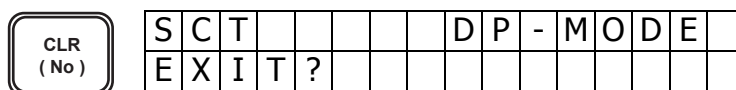
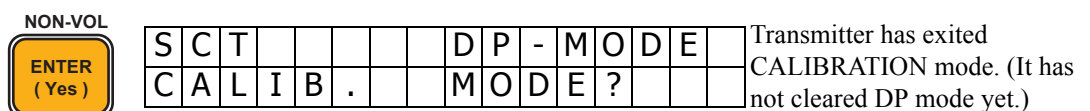
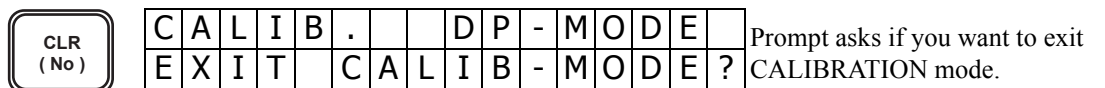
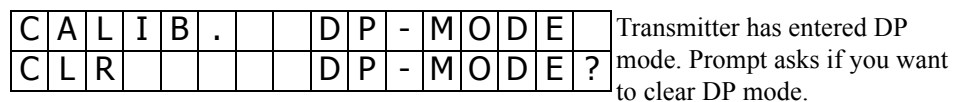
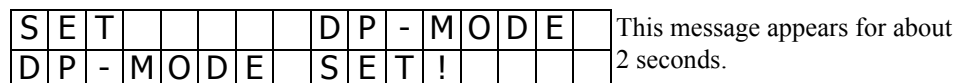
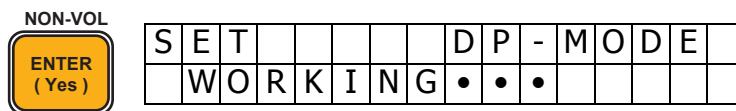

Calibrating the URV

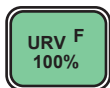

D	P	-	U	R	V		D	P	-	M	O	D	E	
	1	0	0				k	P	a				d	#

Pressure URV setting stored in transmitter's memory appears.



D	P	-	U	R	V		D	P	-	M	O	D	E	
C	O	R	R	E	C	T	D	P	-	U	R	V	?	#

Prompt asks if URV is to be calibrated to the applied reference pressure. Make sure that the reference input pressure conforms with URV



D	P	-	U	R	V		D	P	-	M	O	D	E	
A	R	E		Y	O	U	S	U	R	E		!	?	

Prompt asks you to confirm the entry once more.



D	P	-	U	R	V		D	P	-	M	O	D	E	
	W	O	R	K	I	N	G	.	.	.				

When you press [ENTER], the URV is calibrated to the reference input pressure (span calibration). This takes about 20 seconds.

D	P	-	U	R	V		D	P	-	M	O	D	E	
D	P	-	U	R	V		C	O	R	R	E	C	T	#

End of calibration.

To exit the DP



S	C	T					D	P	-	M	O	D	E	
S	E	C	O	N	D	.	V	A	L	U	E	?		

Press the



key 7 times or the



key twice.

S	C	T					D	P	-	M	O	D	E	
C	A	L	I	B			M	O	D	E				

Prompt asks if you want to enter CALIBRATION mode.



C	A	L	I	B			D	P	-	M	O	D	E	
C	L	R					D	P	-	M	O	D	E	?

Prompt asks if you want to clear DP mode.



C	L	R					D	P	-	M	O	D	E	
A	R	E		Y	O	U		S	U	R	E	!	?	

Prompt requests you to confirm it once more.



C	L	R					D	P	-	M	O	D	E	
	W	O	R	K	I	N	G	.	.	.				

C	L	R					D	P	-	M	O	D	E	
D	P	-	M	O	D	E	C	L	R	!				

DP mode has been cleared.

C	A	L	I	B	.		M	O	D	E					
E	X	I	T		C	A	L	I	B	-	M	O	D	E	?

Prompt asks if you want to exit CALIBRATION mode.



S	C	T					C	O	N	F	I	G		
C	A	L	I	B			M	O	D	E	?			

Prompt asks if you want to enter CALIBRATION mode.

4-4-3: How to restore the initial calibration data

If you enter incorrect calibration data, you may want to restore the initial calibration data (data provided when the transmitter was shipped from the factory). To do this, follow the procedure shown below.

Set the transmitter to the DP mode

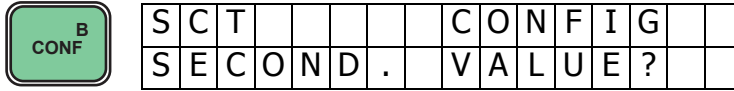

Press the key 8 times or the key thrice.

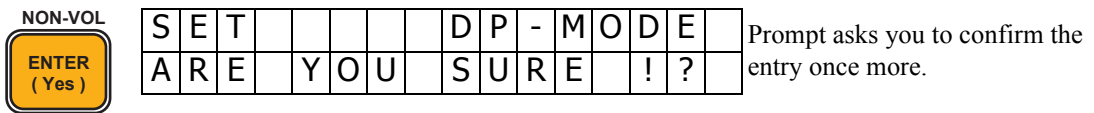
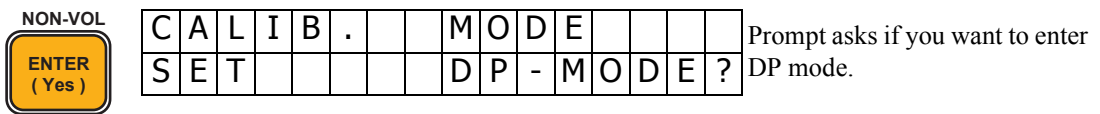
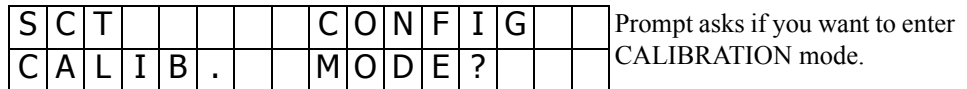

[If you don't want to enter DP mode, press the key.]

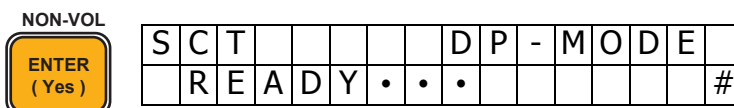
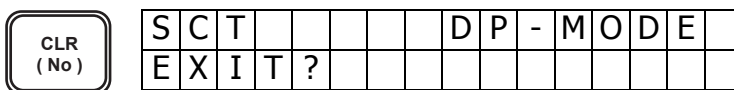
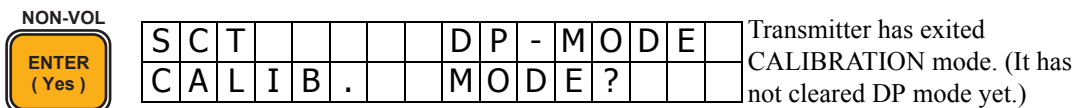
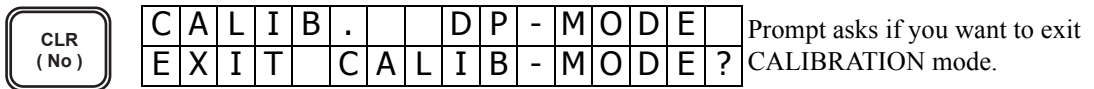
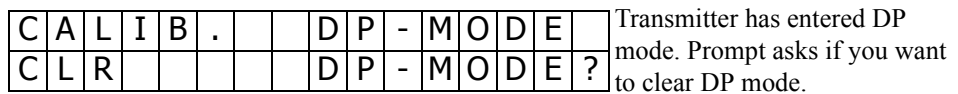
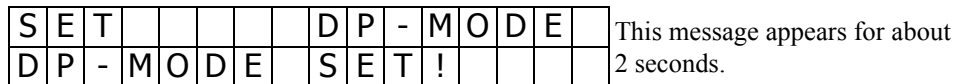
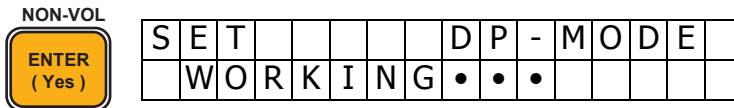

Restoring the initial calibration data



				S	H	I	F	T	-					
														#



S	C	T						D	P	-	M	O	D	E		
R	E	S	E	T				D	P	-	C	O	R	R	?	#



S	C	T						D	P	-	M	O	D	E	
	W	O	R	K	I	N	G	.	.	.					



S	C	T						D	P	-	M	O	D	E	
D	P	-	C	O	R	R		R	E	S	E	T			#

Initial calibration data has been restored.

To exit the DP



S	C	T						D	P	-	M	O	D	E	
S	E	C	O	N	D	.		V	A	L	U	E	?		

Press the  key 7 times or the  key twice.

S	C	T						D	P	-	M	O	D	E	
C	A	L	I	B	.			M	O	D	E	?			

Prompt asks if you want to enter CALIBRATION mode.



C	A	L	I	B	.			D	P	-	M	O	D	E	
C	L	R						D	P	-	M	O	D	E	?

Prompt asks if you want to clear DP mode.



C	L	R						D	P	-	M	O	D	E	
A	R	E		Y	O	U		S	U	R	E	!	?		

Prompt requests you to confirm it once more.



C	L	R						D	P	-	M	O	D	E	
	W	O	R	K	I	N	G	.	.	.					

C	L	R						D	P	-	M	O	D	E	
D	P	-	M	O	D	E		C	L	R					

DP mode has been cleared.

C	A	L	I	B	.			M	O	D	E				
E	X	I	T		C	A	L	I	B	-	M	O	D	E	?

Prompt asks if you want to exit CALIBRATION mode.



S	C	T						C	O	N	F	I	G		
C	A	L	I	B				M	O	D	E	?			

Prompt asks if you want to enter CALIBRATION mode.

4-5: Calibrating the static pressure sensor

To calibrate the instrument as a static pressure transmitter in analog output mode, set it in PP mode. (Refer to “4-2: Operation modes and calibrated items”.) However, you may use the MEASURE mode to calibrate it at atmospheric pressure.

4-5-1: Calibration at atmospheric pressure

To calibrate the transmitter at 1 atmospheric pressure (101.3 kPa {1.033 kgf/cm²} abs.), proceed as follows:

Calibration in MEASURE mode



				S	H	I	F	T	-						
															#

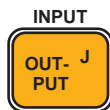

D	P	-	I	N	P	T		M	A	S	-	1	0	0	
W	O	R	K	I	N	G	.	.	.						

D	P	-	I	N	P	T		M	A	S	-	1	0	0	
0	.	0	0	5				k	P	a					d

Present differential pressure input (0.005 kPa in this example) appears.
 ↑ Denotes a differential pressure



P	P	-	I	N	P	T		M	A	S	-	1	0	0	
0	.	1						k	P	a					g

Present static input pressure (0.1 kPa in this example) appears.
 For switching between gauge pressure (g) and absolute pressure (a), refer to 4-1-3 (5)-2.

↑ Denotes a gauge pressure

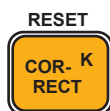

P	P	-	I	N	P	T		M	A	S	-	1	0	0	
		Z	E	R	O			I	N	P	U	T	?		

Prompt asks if the zero input is to be calibrated in this state. Be sure that the input is 1 atmospheric pressure (101.3 kPa {1.033 kgf/cm²} abs.)



P	P	-	I	N	P	T		M	A	S	-	1	0	0	
A	R	E		Y	O	U		S	U	R	E		!	?	

Prompt asks you to confirm it once more.



P	P	-	I	N	P	T		M	A	S	-	1	0	0	
W	O	R	K	I	N	G	.	.	.						

P	P	-	I	N	P	T		M	A	S	-	1	0	0	
		I	N	P	U	T		Z	E	R	O	E	D		



Transmitter has been calibrated for input zero with the atmospheric pressure.

Calibration in the PP mode

Set the transmitter to the PP mode



S	C	T					D	P	-	M	O	D	E	
S	E	C	O	N	D	.	V	A	L	U	E	?		

Press the  key 8 times or the  key thrice.

S	C	T					D	P	-	M	O	D	E	
C	A	L	I	B	.		M	O	D	E	?			

 Prompt asks if you want to enter CALIBRATION mode.



C	A	L	I	B	.		M	O	D	E				
S	E	T					P	P	-	M	O	D	E	?

 Prompt asks if you want to enter DP mode.



C	L	R					M	O	D	E				
S	E	T					P	P	-	M	O	D	E	?

 Prompt asks if you want to clear PP mode.



C	L	R					D	P	-	M	O	D	E	
A	R	E		Y	O	U	S	U	R	E	!	?		

 Prompt requests you to confirm the entry once more.

[If you don't want to enter PP mode, press the  key.]



S	E	T					P	P	-	M	O	D	E	
	W	O	R	K	I	N	G	.	.	.				

S	E	T					P	P	-	M	O	D	E	
P	P	-	M	O	D	E	S	E	T	!				

 This message appears about 2 seconds.

C	A	L	I	B	.		P	P	-	M	O	D	E	
C	L	R					P	P	-	M	O	D	E	

 Transmitter has entered PP mode. Prompt asks if you want to clear P mode.



C	A	L	I	B	.		P	P	-	M	O	D	E		
E	X	I	T		C	A	L	I	B	-	M	O	D	E	?

 Prompt asks if you want to exit CALIBRATION mode.



S	C	T					P	P	-	M	O	D	E	
C	A	L	I	B	.		M	O	D	E	?			

 Transmitter has exited CALIBRATION mode. (It has not cleared PP mode yet)

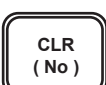

C	A	L	I	B	.		P	P	-	M	O	D	E	
E	X	I	T	?										



S	C	T					P	P	-	M	O	D	E	
	R	E	A	D	Y	.	.	.						#

 ← Symbol # indicates that instrument is in PP mode.

Calibrating the zero point



				S	H	I	F	T	-				
													#

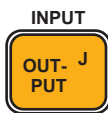

P	P	-	I	N	P	T		P	P	-	M	O	D	E
	0	.	1					k	P	a			g	#

Present static input pressure (0.1 kPa g in this example) appears.

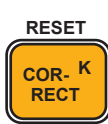

P	P	-	I	N	P	T		P	P	-	M	O	D	E
		Z	E	R	O		I	N	P	U	T	?		#

Prompt asks if the zero input is to be calibrated in this state. Be sure that the input is 1 atmospheric pressure (101.3 kPa {1.033 kgf/cm²}abs.)



P	P	-	I	N	P	T		P	P	-	M	O	D	E
	A	R	E		Y	O	U		S	U	R	E	!	?

Prompt requests you to confirm it once more.



P	P	-	I	N	P	T		P	P	-	M	O	D	E
	W	O	R	K	I	N	G	.	.	.				



P	P	-	I	N	P	T		P	P	-	M	O	D	E
		I	N	P	U	T		Z	E	R	O	E	D	#

Transmitter has been calibrated for input zero with the atmospheric pressure.

To exit the PP mode



S	C	T						P	P	-	M	O	D	E
	S	E	C	O	N	D	.		V	A	L	U	E	?

Press the  key 7 times or the  key twice.

S	C	T						P	P	-	M	O	D	E
	C	A	L	I	B	.		M	O	D	E	?		

Prompt asks if you want to enter CALIBRATION mode.



C	A	L	I	B	.			P	P	-	M	O	D	E	
	C	L	R					P	P	-	M	O	D	E	?

Prompt asks if you want to clear PP mode.



C	L	R						P	P	-	M	O	D	E
	A	R	E		Y	O	U		S	U	R	E	!	?

Prompt requests you to confirm it once more.



C	L	R						P	P	-	M	O	D	E
	W	O	R	K	I	N	G	.	.	.				

C	L	R						P	P	-	M	O	D	E
	P	P	-	M	O	D	E		C	L	R			

PP mode has been cleared.

C	A	L	I	B	.			M	O	D	E				
E	X	I	T		C	A	L	I	B	-	M	O	D	E	?

Prompt asks if you want to exit CALIBRATION mode.



S	C	T						C	O	N	F	I	G	
C	A	L	I	B				M	O	D	E	?		

Prompt asks if you want to enter CALIBRATION mode.

4-5-2: Calibrating pressure range

You calibrate the zero point and pressure range of the transmitter. For analog output operation, calibrate the instrument in PP mode. For higher calibration accuracy, it is recommended to calibrate the transmitter with absolute pressures. If you use gauge pressures, deviations of the actual atmospheric pressure from 1 atmospheric pressure are reflected into inaccuracies of calibration.

Setting LRV



To calibrate LRV, apply a reference input pressure for LRV to both high and low pressure chambers of the transmitter and calibrate it through the SFC. If the reference input pressure and LRV do not conform, make them conform first.

~Note *Always calibrate the LRV first, even when the range is reversed.*

Set the transmitter to PP mode



S	C	T						C	O	N	F	I	G	
S	E	C	O	N	D	.		V	A	L	U	E	?	

Press the  key 8 times or the  key thrice.

S	C	T						C	O	N	F	I	G	
C	A	L	I	B				M	O	D	E	?		

Prompt asks if you want to enter CALIBRATION mode.



C	A	L	I	B				M	O	D	E				
S	E	T						D	P	-	M	O	D	E	?

Prompt asks if you want to enter DP mode.



C	L	R						M	O	D	E				
S	E	T						P	P	-	M	O	D	E	?

Prompt asks if you want to clear PP mode.

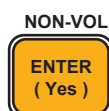

C	L	R						D	P	-	M	O	D	E	
A	R	E		Y	O	U		S	U	R	E		!	?	

Prompt requests you to confirm the entry once more.

[If you don't want to enter PP mode, press the  key.]

NON-VOL  SET PP - MODE
WORKING •••

SET PP - MODE
PP - MODE SET!

This message appears for about 2 seconds.

CALIB . PP - MODE
CLR PP - MODE ?

Transmitter has entered PP mode. Prompt asks if you want to clear PP mode.

 CALIB . PP - MODE
EXIT CALIB - MODE ?

Prompt asks if you want to exit CALIBRATION mode.

NON-VOL  SCT PP - MODE
CALIB . MODE ?

Transmitter has exited CALIBRATION mode. (It has not cleared PP mode yet.)

 SCT PP - MODE
EXIT ?

NON-VOL  SCT PP - MODE
READY ••• #

Calibrating the LRV

 PP - LRV PP - MODE
0 . 0 0 0 0 k P a g #

Pressure LRV setting stored in transmitter's memory appears.

RESET  PP - LRV PP - MODE
CORRECT PP - LRV ? #

Prompt asks if LRV is to be calibrated to the applied reference pressure. Make sure that the reference input pressure conforms with LRV

NON-VOL  PP - LRV PP - MODE
ARE YOU SURE ! ?

Prompt requests you to confirm the entry once more.

NON-VOL  PP - LRV PP - MODE
WORKING •••



As you press [ENTER], the LRV is calibrated to the reference input pressure. (zero calibration) This takes about 20 seconds.

PP - LRV PP - MODE
PP - LRV CORRECT #

End of calibration procedure.

To exit the PP mode

	S	C	T					P	P	-	M	O	D	E	
	S	E	C	O	N	D	.		V	A	L	U	E	?	

Press the  key 7 times or the  key twice.

S	C	T						P	P	-	M	O	D	E	
C	A	L	I	B	.			M	O	D	E	?			

Prompt asks if you want to enter CALIBRATION mode.

	C	A	L	I	B	.			P	P	-	M	O	D	E
	C	L	R						P	P	-	M	O	D	E

Prompt requests you to confirm the entry once more.

	C	L	R						P	P	-	M	O	D	E
	A	R	E		Y	O	U		S	U	R	E	!	?	

Prompt requests you to confirm it once more.

	C	L	R						P	P	-	M	O	D	E
		W	O	R	K	I	N	G	.	.	.				

C	L	R							P	P	-	M	O	D	E
P	P	-	M	O	D	E		C	L	R					

PP mode has been cleared.

C	A	L	I	B	.			M	O	D	E				
E	X	I	T		C	A	L	I	B	-	M	O	D	E	?

Prompt asks if you want to exit CALIBRATION mode.

	S	C	T						C	O	N	F	I	G	
	C	A	L	I	B				M	O	D	E	?		



Prompt asks if you want to enter CALIBRATION mode.

Setting URV

To calibrate URV, apply a reference input pressure for URV to both high and low pressure chambers of the transmitter and calibrate it through the SFC. If the reference input pressure and URV do not conform, make them conform first.

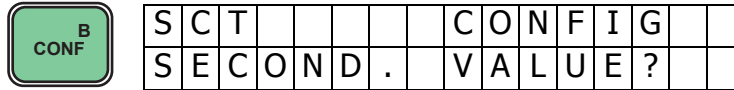
Set the transmitter to PP mode



Press the  key 8 times or the  key thrice.

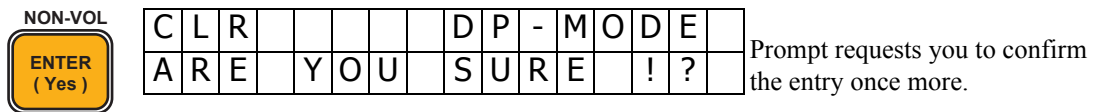
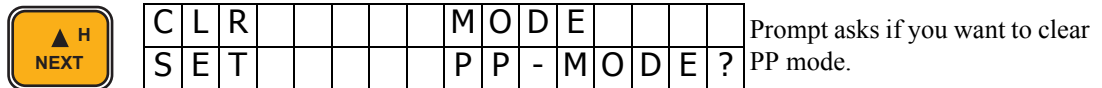
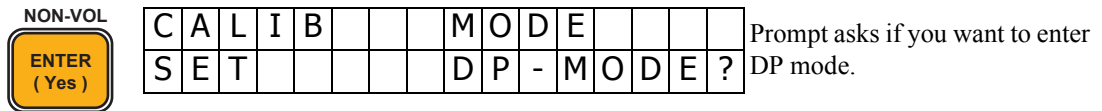
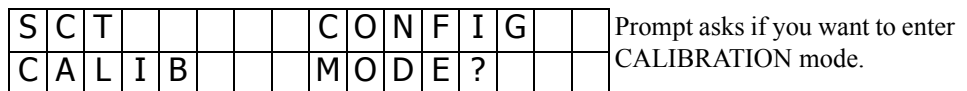

[If you don't want to enter PP mode, press the  key.]

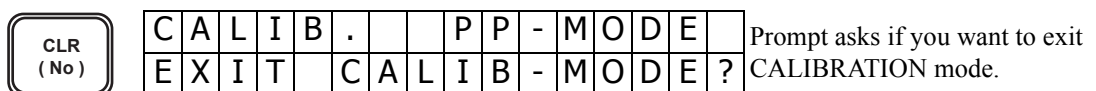
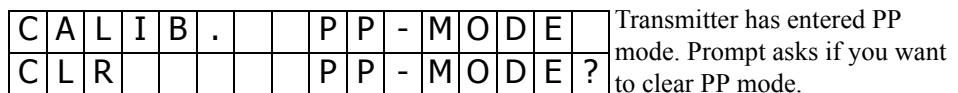
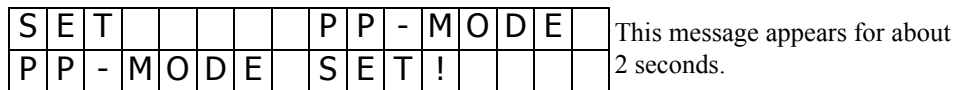
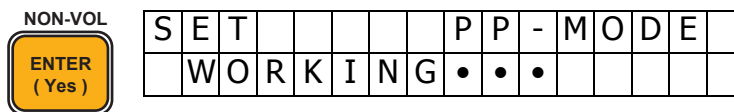

NON-VOL ENTER (Yes)	S	C	T					P	P	-	M	O	D	E	
	C	A	L	I	B	.		M	O	D	E	?			

Transmitter has exited CALIBRATION mode. (It has not cleared DP mode yet.)

CLR (No)	S	C	T					P	P	-	M	O	D	E	
	E	X	I	T	?										

NON-VOL ENTER (Yes)	S	C	T					P	P	-	M	O	D	E	
		R	E	A	D	Y	.	.	.						#

Calibrating the URV

URV F 100%	P	P	-	U	R	V		P	P	-	M	O	D	E	
	2	5	0	0				k	P	a				g	#

Pressure URV setting stored in transmitter's memory appears.

RESET COR- K RECT	P	P	-	U	R	V		P	P	-	M	O	D	E	
	C	O	R	R	E	C	T		P	P	-	U	R	V	?

Prompt asks if URV is to be calibrated to the applied reference pressure. Make sure that the reference input pressure conforms with URV

NON-VOL ENTER (Yes)	P	P	-	U	R	V		P	P	-	M	O	D	E	
	A	R	E		Y	O	U		S	U	R	E		!	?

Prompt requests you to confirm the entry once more.

NON-VOL ENTER (Yes)	P	P	-	U	R	V		P	P	-	M	O	D	E	
		W	O	R	K	I	N	G	.	.	.				

As you press [ENTER], the URV is calibrated to the reference input pressure (span calibration). This takes about 20 seconds.



P	P	-	L	R	V			P	P	-	M	O	D	E	
P	P	-	L	R	V			C	O	R	R	E	C	T	#

End of calibration procedure.

To exit the PP mode



S	C	T					P	P	-	M	O	D	E	
S	E	C	O	N	D	.	V	A	L	U	E	?		

Press the  key 7 times or the  key twice.

S	C	T					P	P	-	M	O	D	E	
C	A	L	I	B	.		M	O	D	E	?			

Prompt asks if you want to enter CALIBRATION mode.



C	A	L	I	B	.		P	P	-	M	O	D	E	
C	L	R					P	P	-	M	O	D	E	?

Prompt asks if you want to clear PP mode.



C	L	R					P	P	-	M	O	D	E	
A	R	E	Y	O	U	S	U	R	E	!	?			

Prompt requests you to confirm it once more.



C	L	R					P	P	-	M	O	D	E	
	W	O	R	K	I	N	G	.	.	.				

C	L	R					P	P	-	M	O	D	E	
P	P	-	M	O	D	E	C	L	R					

PP mode has been cleared.

C	A	L	I	B	.		M	O	D	E				
E	X	I	T	C	A	L	I	B	-	M	O	D	E	?

Prompt asks if you want to exit CALIBRATION mode.



S	C	T					C	O	N	F	I	G		
C	A	L	I	B			M	O	D	E	?			



Prompt asks if you want to enter CALIBRATION mode.

4-5-3: How to restore the initial calibration data

If you have entered incorrect calibration data, you may want to restore the initial calibration data (provided when the transmitter was shipped from the factory). To do this, follow the procedure shown below.

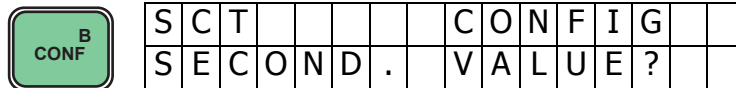
Set the transmitter to the PP mode



Press the  key 8 times or the  key thrice.

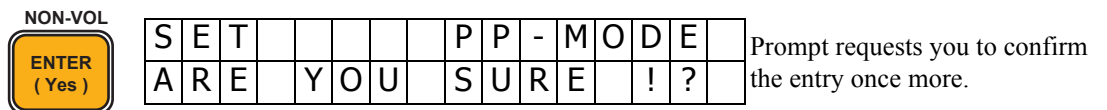
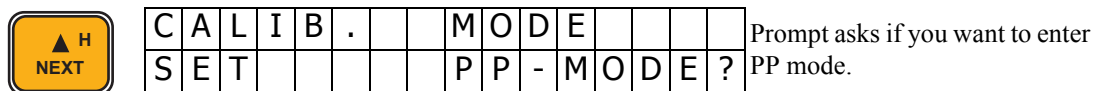
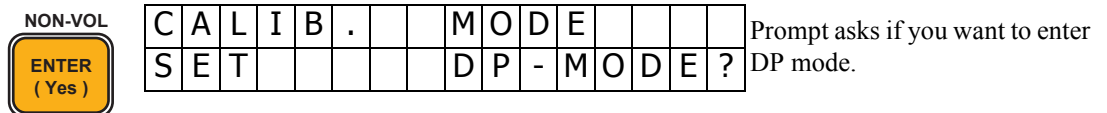
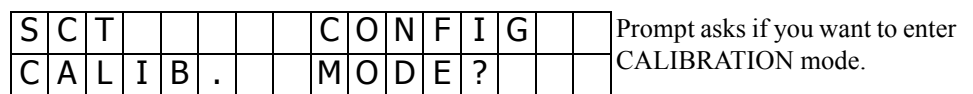

[If you don't want to enter PP mode, press the  key.]

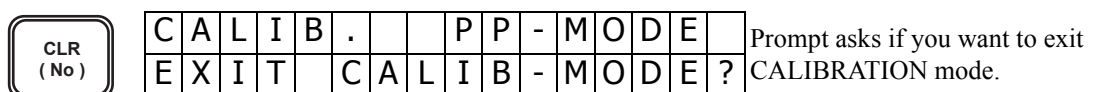
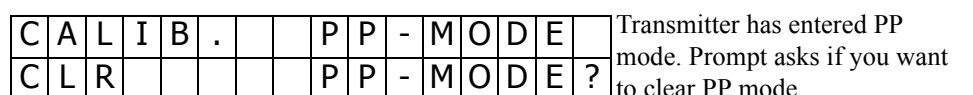
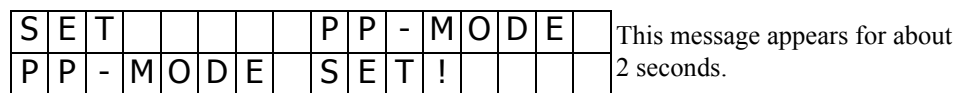
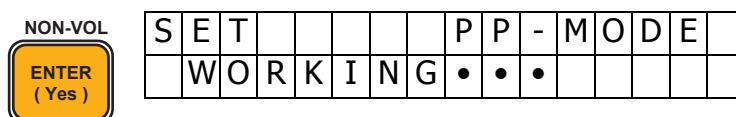

NON-VOL ENTER (Yes)	S C T P P - M O D E	Transmitter has exited CALIBRATION mode. (It has not cleared PP mode yet.)
	C A L I B M O D E ?	

CLR (No)	S C T P P - M O D E
	E X I T ?

NON-VOL ENTER (Yes)	S C T P P - M O D E
	R E A D Y . . . #

Restoring the initial calibration data

SHIFT [^] S H I F T -
 #

RESET COR- K RECT	S C T P P - M O D E
	R E S E T P P - C O R R ? #

NON-VOL ENTER (Yes)	S C T P P - M O D E
	W O R K I N G . . .

S C T P P - M O D E	Initial calibration has been restored.
P P - C O R R R E S E T #	

To exit the PP mode



S	C	T					P	P	-	M	O	D	E	
S	E	C	O	N	D	.	V	A	L	U	E	?		

Press the



key 7 times or the



key twice.

S	C	T					P	P	-	M	O	D	E	
C	A	L	I	B	.		M	O	D	E	?			

Prompt asks if you want to enter CALIBRATION mode.



C	A	L	I	B	.		P	P	-	M	O	D	E	
C	L	R					P	P	-	M	O	D	E	?

Prompt asks if you want to clear PP mode.



C	L	R					P	P	-	M	O	D	E	
A	R	E		Y	O	U		S	U	R	E	!	?	

Prompt requests you to confirm it once more.



C	L	R					P	P	-	M	O	D	E	
	W	O	R	K	I	N	G	.	.	.				

C	L	R					P	P	-	M	O	D	E	
P	P	-	M	O	D	E	C	L	R					

PP mode has been cleared.

C	A	L	I	B	.		M	O	D	E					
E	X	I	T		C	A	L	I	B	-	M	O	D	E	?

Prompt asks if you want to exit CALIBRATION mode.



S	C	T					C	O	N	F	I	G		
C	A	L	I	B			M	O	D	E	?			

Prompt asks if you want to enter CALIBRATION mode.

4-6: Calibrating the temperature sensor

To calibrate the instrument for temperature sensing in analog output mode, set it to PT mode (refer to “4-2: Operation modes and calibrated items”).

4-6-1: Calibrating temperature range



Calibrate the zero point and range of temperature sensing as described below.

Setting LRV

To calibrate LRV, apply a reference input value for LRV. Calibrate the transmitter through the SFC. If the reference input value and LRV do not conform, make them conform first.

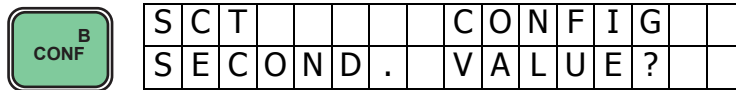
Set the transmitter to PT mode



Press the  key 8 times or the  key thrice.

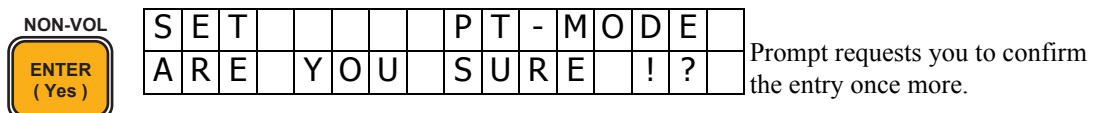
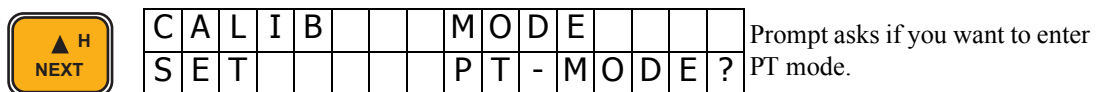
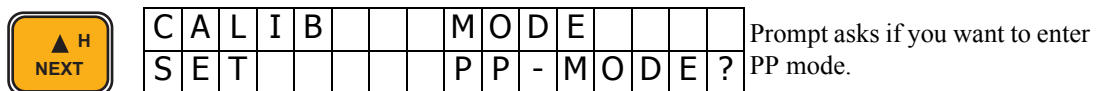
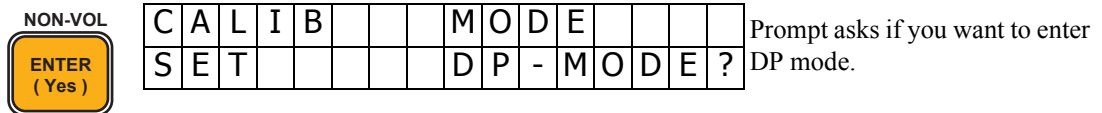
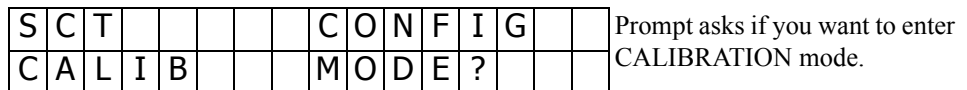

[If you don't want to enter PT mode, press the  key.]



S	E	T					P	T	-	M	O	D	E	
	W	O	R	K	I	N	G	.	.	.				

S	E	T					P	T	-	M	O	D	E	
P	T	-	M	O	D	E	S	E	T	!				

This message appears for about 2 seconds.

C	A	L	I	B	.			P	T	-	M	O	D	E	
C	L	R						P	T	-	M	O	D	E	?

Transmitter has entered PT mode. Prompt asks if you want to clear PT mode.



C	A	L	I	B	.			P	T	-	M	O	D	E	
E	X	I	T		C	A	L	I	B	-	M	O	D	E	?

Prompt asks if you want to exit CALIBRATION mode.



S	C	T						P	T	-	M	O	D	E
C	A	L	I	B	.			M	O	D	E	?		

Transmitter has exited CALIBRATION mode. (It has not cleared PT mode yet.)



S	C	T						P	T	-	M	O	D	E
E	X	I	T	?										



S	C	T						P	T	-	M	O	D	E
	R	E	A	D	Y	.	.	.						#

Calibrating the LRV



P	T	-	L	R	V			P	T	-	M	O	D	E
	0	.	0	0	0	0		°	C				g	#

Pressure LRV setting stored in transmitter's memory appears.

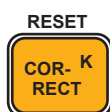

P	T	-	L	R	V			P	T	-	M	O	D	E	
C	O	R	R	E	C	T		P	T	-	L	R	V	?	#

Prompt asks if LRV is to be calibrated to the applied reference pressure. Make sure that the reference input value conforms with LRV



P	T	-	L	R	V			P	T	-	M	O	D	E
A	R	E		Y	O	U		S	U	R	E	!	?	

Prompt requests you to confirm the entry once more.



P	T	-	L	R	V			P	T	-	M	O	D	E
	W	O	R	K	I	N	G	.	.	.				

As you press [ENTER], the LRV is calibrated to the reference input value. This takes about 20 seconds.

P	T	-	L	R	V			P	T	-	M	O	D	E	
P	T	-	L	R	V			C	O	R	R	E	C	T	#

End of calibration procedure.

To exit the PT mode



S	C	T				P	T	-	M	O	D	E	
S	E	C	O	N	D	.	V	A	L	U	E	?	

Press the



key 7 times or the



key twice.

S	C	T				P	T	-	M	O	D	E	
C	A	L	I	B	.	M	O	D	E	?			

Prompt asks if you want to enter CALIBRATION mode.



C	A	L	I	B	.	P	T	-	M	O	D	E	
C	L	R				P	T	-	M	O	D	E	?

Prompt asks if you want to clear PT mode.



C	L	R				P	T	-	M	O	D	E	
A	R	E	Y	O	U	S	U	R	E	!	?		

Prompt requests you to confirm it once more.



C	L	R				P	T	-	M	O	D	E	
	W	O	R	K	I	N	G	.	.	.			

C	L	R				P	T	-	M	O	D	E	
P	T	-	M	O	D	E	C	L	R				

PT mode has been cleared.

C	A	L	I	B	.	M	O	D	E					
E	X	I	T	C	A	L	I	B	-	M	O	D	E	?

Prompt asks if you want to exit CALIBRATION mode.



S	C	T				C	O	N	F	I	G		
C	A	L	I	B		M	O	D	E	?			



Prompt asks if you want to enter CALIBRATION mode.

Setting URV

To calibrate URV apply a reference input value for URV. Calibrate the transmitter through the SFC. If the referentc input value and URV do not conform, make them conform first.

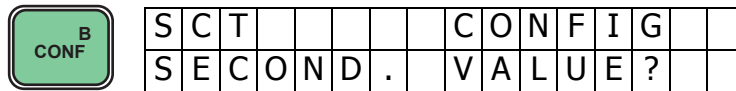
Set the transmitter to PT mode



Press the  key 8 times or the  key thrice.

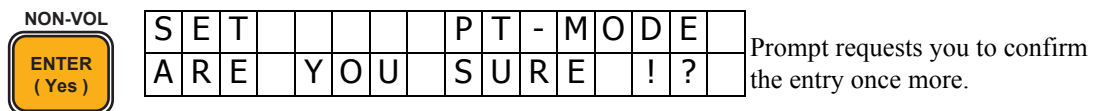
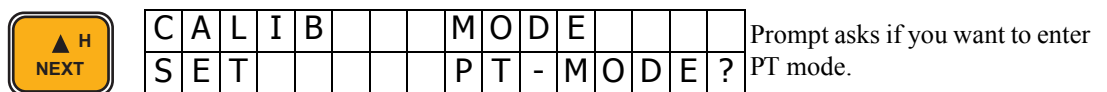
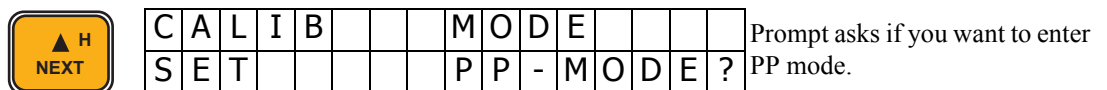
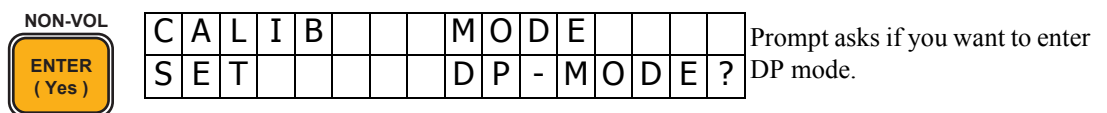
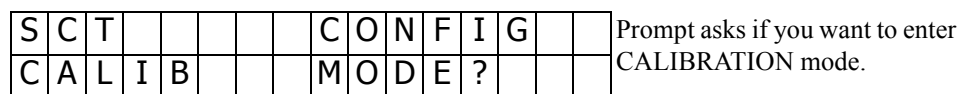

[If you don't want to enter PT mode, press the  key.]

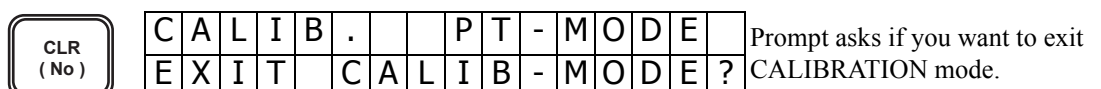
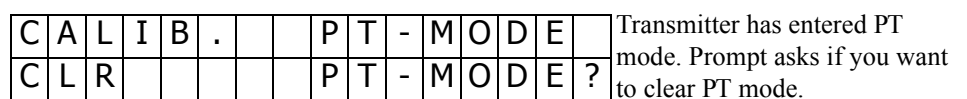
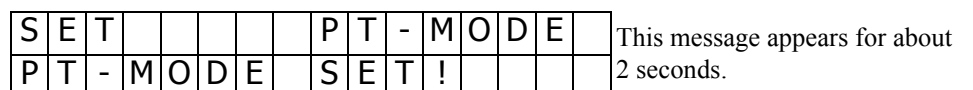
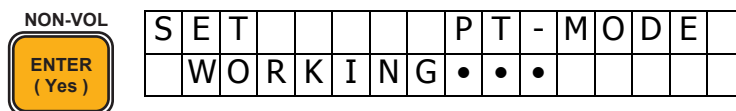

NON-VOL

S	C	T				P	T	-	M	O	D	E	
C	A	L	I	B	.		M	O	D	E	?		

Transmitter has exited CALIBRATION mode. (It has not cleared PT mode yet.)



S	C	T				P	T	-	M	O	D	E	
E	X	I	T	?									

NON-VOL



S	C	T				P	T	-	M	O	D	E	
	R	E	A	D	Y	.	.	.					#

Calibrating the URV



P	T	-	U	R	V		P	T	-	M	O	D	E	
	1	0	0	.	0		°	C				g	#	

Present URV setting stored in transmitter's memory appears.

RESET



P	T	-	U	R	V		P	T	-	M	O	D	E	
C	O	R	R	E	C	T	P	T	-	U	R	V	?	#

SFC asks if URV is to be calibrated to the applied reference value.

NON-VOL

P	T	-	U	R	V		P	T	-	M	O	D	E	
A	R	E		Y	O	U		S	U	R	E	!	?	

Prompt requests you to confirm the entry once more.

NON-VOL



P	T	-	U	R	V		P	T	-	M	O	D	E	
	W	O	R	K	I	N	G	.	.	.				



As you press [ENTER], the URV is calibrated to the reference input value (span calibration). This takes about 20 seconds.

P	T	-	U	R	V		P	T	-	M	O	D	E	
P	T	-	L	R	V		C	O	R	R	E	C	T	#

End of calibration procedure.

To exit the PT mode

	S	C	T					P	T	-	M	O	D	E	
	S	E	C	O	N	D	.		V	A	L	U	E	?	

Press the  key 7 times or the  key twice.

S	C	T						P	T	-	M	O	D	E	
C	A	L	I	B	.			M	O	D	E	?			

Prompt asks if you want to enter CALIBRATION mode.

	C	A	L	I	B	.					P	T	-	M	O	D	E	
	C	L	R								P	T	-	M	O	D	E	?

Prompt asks if you want to clear PT mode.

	C	L	R								P	T	-	M	O	D	E	
	A	R	E		Y	O	U		S	U	R	E		!	?			

Prompt requests you to confirm the entry once more.

	C	L	R								P	T	-	M	O	D	E	
		W	O	R	K	I	N	G	.	.	.							

C	L	R									P	T	-	M	O	D	E	
P	T	-	M	O	D	E		C	L	R								

PT mode has been cleared.

C	A	L	I	B	.						M	O	D	E				
E	X	I	T		C	A	L	I	B	-	M	O	D	E	?			

Prompt asks if you want to exit CALIBRATION mode.

	S	C	T								C	O	N	F	I	G		
	C	A	L	I	B	.					M	O	D	E	?			

Prompt asks if you want to enter CALIBRATION mode.

4-6-2: How to restore the initial calibration data

If you have entered incorrect calibration data, you may want to restore the initial calibration data (the data provided when the transmitter was shipped from the factory). To do this, follow the procedure shown below.

Set the transmitter to PT mode

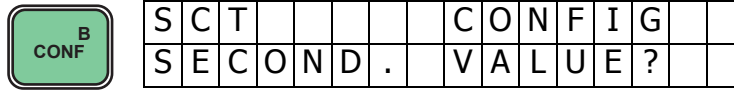

Press the key 8 times or the key thrice.

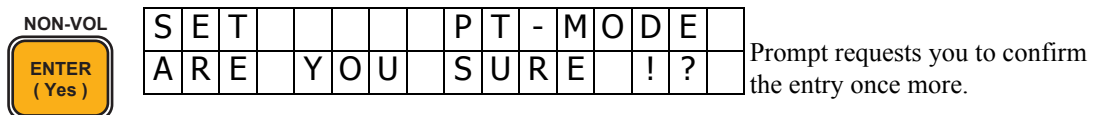
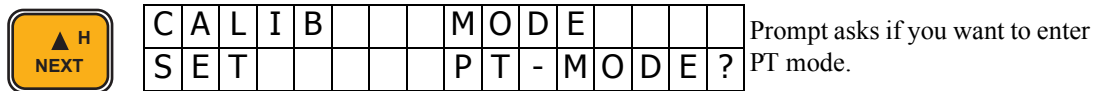
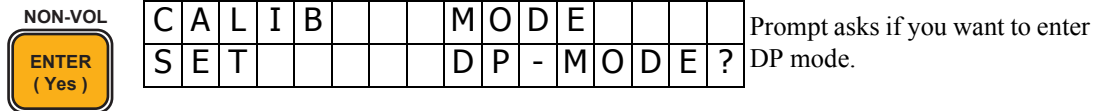
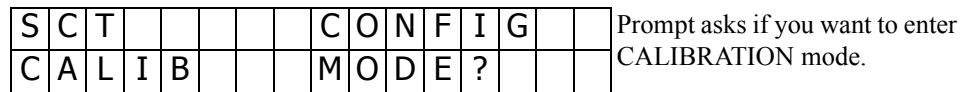

[If you don't want to enter PT mode, press the key.]

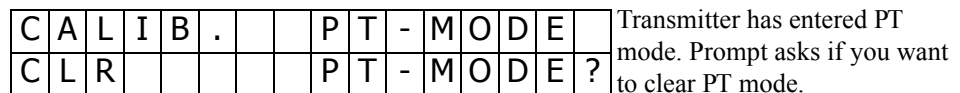
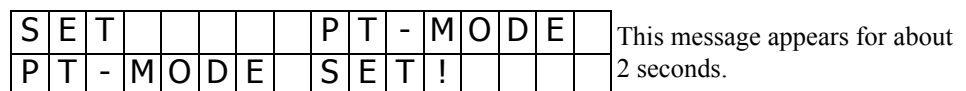
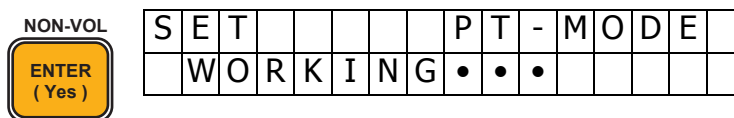

CLR (No)	C	A	L	I	B	.			P	T	-	M	O	D	E	
	E	X	I	T		C	A	L	I	B	-	M	O	D	E	?

Prompt asks if you want to exit CALIBRATION mode.

NON-VOL ENTER (Yes)	S	C	T						P	T	-	M	O	D	E	
	C	A	L	I	B	.			M	O	D	E	?			

Transmitter has exited CALIBRATION mode. (It has not cleared PP mode yet.)

CLR (No)	S	C	T						P	T	-	M	O	D	E	
	E	X	I	T	?											

NON-VOL ENTER (Yes)	S	C	T						P	T	-	M	O	D	E	
		R	E	A	D	Y	.	.	.							#

Restoring the initial calibration data

SHIFT ^					S	H	I	F	T	-						
																#

RESET COR- K RECT	S	C	T						P	T	-	M	O	D	E	
	R	E	S	E	T		P	P	-	C	O	R	R	?		#



NON-VOL ENTER (Yes)	S	C	T						P	T	-	M	O	D	E	
		W	O	R	K	I	N	G	.	.	.					

S	C	T							P	T	-	M	O	D	E	
P	T	-	C	O	R	R		R	E	S	E	T				#

Initial calibration has been restored.

To exit the PT mode

CONF B	S	C	T						P	T	-	M	O	D	E	
	S	E	C	O	N	D	.		V	A	L	U	E	?		

Press the  key 7 times or the  key twice.

S	C	T							P	T	-	M	O	D	E	
C	A	L	I	B	.				M	O	D	E	?			

Prompt asks if you want to enter CALIBRATION mode.

NON-VOL ENTER (Yes)	C	A	L	I	B	.			P	T	-	M	O	D	E	
	C	L	R						P	T	-	M	O	D	E	?

Prompt asks if you want to clear PT mode.



C	L	R				P	T	-	M	O	D	E	
A	R	E		Y	O	U		S	U	R	E	!	?

Prompt requests you to confirm it once more.



C	L	R				P	T	-	M	O	D	E	
	W	O	R	K	I	N	G	.	.	.			

C	L	R				P	T	-	M	O	D	E	
P	T	-	M	O	D	E		C	L	R			

PT mode has been cleared.

C	A	L	I	B	.		M	O	D	E					
E	X	I	T		C	A	L	I	B	-	M	O	D	E	?

Prompt asks if you want to exit CALIBRATION mode.



S	C	T				C	O	N	F	I	G		
C	A	L	I	B		M	O	D	E	?			

Prompt asks if you want to enter CALIBRATION mode.

Chapter 5 : Identifying and Interpreting Diagnostic Messages

The SFC and model JTD720A transmitter are constantly perform self-diagnostics to monitor the functions and status of the control loop and communications link.

When a diagnostic failure is detected, a corresponding message is displayed on the SFC display. This section defines the various diagnostic messages and what they mean so you can easily interpret them.

5-1: Diagnostic categories

The diagnostics can be grouped into one of these four categories:

- Non-critical failures
- Critical failures
- Communication errors
- Invalid key entry errors

5-1-1: Non critical failures

Effects on SFC operation

- All SFC functions remains operational.
- The transmitter’s tag number appears in the top row of the display and the error message appears in the bottom row along with the “#” sign as the last character in the row.
- If the differential pressure is higher than 100 kPa {1 kgf/cm²}, the output indication is driven beyond the high or low scale limit. This state may occur when the transmitter is in MEASURE or other modes as follows:

MEASURE mode	Output indication is driven off the high or low scale limit.
DP mode (differential pressure)	
PP mode (static pressure)	
PT mode (temperature)	
INPUT mode (simulated input)	

Summary of message

Abbreviations used in messages are as follows:

- DP mode: Differential pressure mode
- PP mode: Static pressure mode
- PT mode: Temperature mode
- INPUT mode: Simulated input mode
- OUTPUT mode: Constant-current source mode

Table 5-1

Message	Description
DP CORRECT RESET #	Must recalibrate DP sensor to attain required accuracy

Table 5-1

Message	Description
DP M.B. FAULT #	DP meter body has failed
DP M.B. OVERLOAD #	DP input pressure is more than 1.1 times greater than the allowable range
EXCESS DP-ZERO #	DP zero calibration value is too large (shift is greater than characterization)
EXCESS DP-SPAN #	DP span calibration value is too large
EXCESS PP-ZERO #	PP zero calibration value is too large
EXCESS PP-SPAN #	PP span calibration value is too large
EXCESS PT-ZERO #	PT zero calibration value is too large
EXCESS PT-SPAN #	PT span calibration value is too large
IN DP MODE #	Transmitter is in DP mode
IN PP MODE #	Transmitter is in PP mode
IN PT MODE #	Transmitter is in PT mode
IN DP - INPUT MODE #	Transmitter is in DP INPUT mode
IN PP - INPUT MODE #	Transmitter is in PP INPUT mode
IN PT - INPUT MODE #	Transmitter is in PT INPUT mode
IN OUTPUT MODE #	Transmitter is in DP OUTPUT mode
IN PP - OUTPUT MODE #	Transmitter is in PP OUTPUT mode
IN PT - OUTPUT MODE #	Transmitter is in PT OUTPUT mode
NO DAC TEMP COMP #	No temperature correction data exists for calculations
NOT IN MES. MODE #	Transmitter is not in MEASURE mode
PP M.B. OVERLOAD #	PP input pressure is more than 2 times greater than the allowable range
PP CORRECT RESET #	Must recalibrate PP sensor to attain required accuracy
PT CORRECT RESET #	Must recalibrate PT sensor to attain required accuracy
PT SENSOR O.L #	Input signal from PT sensor is abnormal
SENSOR OVER TEMP #	Meter body temperature is too high
STATUS UNKNOWN #	Status is unknown

5-1-2: Critical failures

Effects on SFC operation

- The ID, OUTPUT, and STATUS functions remain operational.
- The critical status message is displayed for 3 seconds followed by the PRESS STATUS message.
- The transmitter's tag number appears in the top row of the display and the error message appears in the bottom row.
- The output is driven below the low scale limit value. The output current becomes 3.8 mA or less.

Summary of message

Message	Description
DAC COMP FAULT	D/A converter failure
NVM FAULT	Non-volatile memory failure
RAM FAULT	RAM failure
ROM FAULT	ROM failure
DP CHAR PROM FAULT	DP characterization PROM failure
DP M.B. FAULT	DP meter body failure
DP SUSPECT INPUT	DP input pressure may be incorrect
ELECTRONIC FAULT	PCB failure
ISO μ C FAULT	CPU communication error
PT - CHAR PROM FLT	DT characterization PROM failure
PT - NVM FAULT	PT NVM failure
PT - RAM FAULT	PT RAM failure
PT - ROM FAULT	PT ROM failure
PT - SUSPECT INPUT	PT input temperature may be incorrect

5-1-3: Communication errors

Effects on SFC operation

- All SFC functions are disabled.
- Communication error messages cycle in the display at 2-second intervals.
- The message “NO RESPONSE” appears in the top row of the display, and the error message appears in the bottom row.

Summary of messages

Message	Description
FAILED COMM CHK	Communication is unsuccessful
HI ERS / LO VOLT	Loop resistance is too large or supply voltage is too low
ILLEGAL RESPONSE	Communications failure
INVALID REQUEST	Request is invalid
LOW LOOP RES	Loop resistance is low
NO XMTR RESPONSE	No response from transmitter

5-1-4: Invalid key entry errors

Effects on SFC operation

- The invalid SFC function is disabled.
- Communication error messages are cycled in the display at second intervals.
- Nothing appears in the top row of the display and the error message appears in the bottom row.
- The message “NO RESPONSE” appears in the top row of the display and the error message appears in the bottom row.

Summary of messages

Message	Description
ENTRY > SEN RANGE	Communication is unsuccessful
EXCESSIVE OUTPUT	The output value entered for the constant-current source mode is outside the allowable range
KEY NOT ALLOWED!	Invalid key operation
> RANGE	The computed SFC value is outside the display range

5-2: How to check diagnostic status

The following procedure assumes that the SFC is connected to the transmitter and you have established communications by pressing the [ID] key.

Description



S	C	T					M	A	S	-	1	0	0	
	W	O	R	K	I	N	G	.	.	.				

Details of meter body failures are not displayed. Infer them by referring to the condition of the diaphragms and sensors.

S	C	T					M	A	S	-	1	0	0	
S	T	A	T	U	S		C	H	E	C	=	O	K	

The transmitter and SFC are operating normally.

or

S	C	T					M	A	S	-	1	0	0		
S	E	N	S	O	R		O	V	E	R	T	E	M	P	#

Error message appears for detected faults. See “5-4: Interpreting messages” to interpret message.

then

S	C	T					M	A	S	-	1	0	0	
S	T	A	T	U	S		R	E	C	E	I	V	E	D

Signals end of status messages for display. Press [START] to display last message again. When there are two or more messages they cycle in 5-second intervals.

No.	Message	Description	What to do
8	DATA RESTORED	Saved data is entered in transmitter's memory.	
9	DATA SAVED	Data saved from transmitter to SFC.	
10	ELECTRONIC FAULT	PCB has failed	Change PCB. Do not save data.
11	ENTRY > SEN RANGE	Attempted to set range to a value more than 1.5 times greater than transmitter's range.	Repeat range setting by pressing the [CLR] key and entering a valid value.
12	EXCESS SPAN CORR #	Span correction is too large	Check 100% range calibration input pressure. Calibrate URV. See "Chapter 4 : Calibrating the Transmitter".
13	EXCESS ZERO CORR #	Zero correction is too large.	Check 0% range calibration input pressure. Calibrate URV. See "Chapter 4 : Calibrating the Transmitter".
14	EXCESSIVE OUTPUT	Value entered for constant - current source is outside valid range (-1.2% to 105%).	Press the [CLR] key and enter valid value.
15	FAILED COMM CHK	Communication was unsuccessful. (SFC electronics failure or incorrect connections.)	1. Check polarity of SFC connection. 2. If "COMM ERROR" repeatedly appears as you press the [STAT] key, use a different SFC.
16	F/SAFE DOWNSCALE	For critical failure, burnout protection is driven downscale.	
17	HI RES / LOW VOLT	Loop load resistance is too low or power supply voltage is too low.	Check polarity, wiring, supply voltage, etc.
18	ILLEGAL RESPONSE	Communication failure between SFC and transmitter.	Check load resistance, wiring, etc.
19	INPUT MODE #	Transmitter is in constant-current source mode.	QUIT constant-current source mode by pressing the [OUTPUT] key and then the [CLR] key See "Chapter 3 : Using the SFC to configure and operate your transmitter"
20	INPUT ZEROED	Calibration of sensor in balance state (equilibrium with atmospheric pressure) is complete.	
21	INVALID DATABASE	Transmitter database was invalid when power was turned on.	1. Retry communication. 2. Check database, calibrate transmitter, store data into NVM.

No.	Message	Description	What to do
22	INVALID REQUEST	Repeat is invalid.	Follow correct SFC operating procedure.
23	KEY NOT ALLOWED!	Invalid keystroke.	Press the [CLR] key and follow correct SFC operating procedure.
24	LINEAR	Output characteristics are linear	
25	LOOP IN MANUAL ?	Is control loop in manual mode for communications?	Put loop in manual mode.
26	LOW LOOP RES	Loop resistance is too low	Check loop resistance.
27	LRV CORRECTED	Calibration of LRV is completed.	
28	M.B. OVERLOAD or METER BODY FAULT	Input pressure is more than 2 times greater than valid range.	Check range and, if required, change transmitter for one with a wider range. Transmitter sensor may be damaged. Check its performance.
29	NO XMTR RESPONSE	No response from transmitter (Transmitter failure or loop failure)	1. Retry communication. 2. Press the [STAT] key and take corrective action. 3. Check loop line and SFC connections.
30	NO DAC TEMP COM #		Replace PCB.
31	NOT SUPPORTED	Invalid key operation (key sequence entered is not supported.)	
32	PRESS STATUS	Press the [STATUS] key.	
33	READY	Ready to operate (standby)	
34	RESET CORRECT?	Really erase calibration data?	
35	RESTORE DATA	Really restore data into transmitter?	
36	SAVE DATA?	Is transmitter data to be saved?	
37	SENSOR OVERTEMP #	Sensor temperature is too high. (If sensor remains at this temperature, it will deteriorate and its measuring accuracy will be degraded.)	
38	SET LRV?	Is LRV to be set to the input currently applied?	
39	SET URV?	Is URV to be set to input currently applied?	
40	SFC FAULT	SFC failure	Retry communication. Replaces SFC if necessary.

No.	Message	Description	What to do
41	SHIFT	Selects functions printed in white on the SFC keyboard.	
42	STATUS CHECK = OK	Status check (diagnostics) is normal.	
43	STATUS RECEIVED	All status messages have been retrieved.	
44	STATUS UNKNOWN	Status is unknown.	
45	SQUARE ROOT	Output uses square root extraction.	
46	SUSPECT INPUT	Input may be incorrect. Cause may be in the process, sensor, or electronics of transmitter, or poor connection between ribbon cable plug and PCB connector pins.	Set transmitter to constant-current mode and press the [STAT]. If no message appears, most probable cause of failure is transmitter sensor. Check sensor.
47	URV CORRECTED	Calibration of URV is complete.	
48	WORKING	Transmitter is operating.	
49	ZERO INPUT	Is input zero?	Check that sensor is in equilibrium at atmospheric pressure.
50	> RANGE	Computed display by SFC is greater than display range.	Press the [CLR] key and restart SFC.
51	:	SFC battery is low	Charge battery.
52	#	Non-critical failure	Press the [STAT] key and check messages. After correcting cause of failure, press the [STAT] key to check that the # sign has disappeared.

Document Number:	CM2-DST720-2001
Document Name:	ST3000 Ace Smart Multivariable Transmitter Model JTD720A User's Manual
Date:	Nov. 2004 (First issue)
Issued/Edited by:	Yamatake Corporation

Yamatake Corporation

Totate international Building
2-12-19 Shibuya
Shibuya-ku, Tokyo 150-8316
Japan

Tel : 81-3-3486-2310

Fax : 81-3-3486-2593

YAMATAKE
Savemation

Saving through Automation