

## High Torque Actuators MY940X series

### General

The MY940X series are motorized actuators with a high level of output for use with control valves in various facilities including air-conditioning systems. In combination with the V5063A single-seated two-way valve, the V5064A double-seated two-way valve, and the V5065A mixing three-way valve, they are suitable for controlling large-bore fluid control systems or versions where a high differential pressure is generated during shut-off. The actuators have high/low limit mechanisms and feedback potentiometers (nominally 135 ohm). They also feature ON/OFF and proportional actuation. Obtain the separately available yoke set (QMY9400) before installing the actuators.



### Features

- 1) High power, compact and lightweight: Easy to install, maintain and check valves.
- 2) Manual operation is available with the power off. (Use the attached crank handle to operate the valve.)
- 3) High/low torque limiter and thermal protectors are built in which protect the motors even under overload conditions.

### Model No.

Basic model No.	Applicable valve/size	Power supply	Option	Specifications
MY940				High torque actuator
	0			Two-way valve 3B or less (stroke 19 mm)
	1			Two-way valve 4B to 6B (stroke 38 mm)
	2			Three-way valve 3B or less (stroke 19 mm)
	3			Three-way valve 4B to 6B (stroke 38 mm)
		A		Power supply 100 V AC
		B		Power supply 200 V AC
			0	No option
			1	With two auxiliary switches
				001

**Combination of valve and actuator**

Actuator	Applicable valve model No.		Actuator	Applicable valve model No.	
MY9400	V5063A, VY5063C, VY5064A Series		MY9402	V5065A6001	VY5064A7001
	V5064A6002	VY5064A7002		V5065A6019	VY5064A7019
	V5064A6010	VY5064A7010		V5065A6027	VY5064A7027
	V5064A6028	VY5064A7028		V5065A6035	VY5064A7035
	V5064A6036	VY5064A7036		V5065A6043	VY5064A7043
	V5064A6044	VY5064A7049		V5065A6050	VY5064A7050
MY9401	V5064A6051	VY5064A7051	MY9403	V5065A6068	VY5064A7068
	V5064A6069	VY5064A7069		V5065A6076	VY5064A7076
	V5064A6077	VY5064A7077		V5065A6084	VY5064A7084
			V5065A6092	VY5064A7092	

Check that the model number of the actuator matches the specifications of valves. An incorrect combination may damage the valve or actuator.





**Safety Instructions**

Please read instructions carefully and use the product properly. Please keep this instruction on hand for reference at any time.













**Usage Restrictions**

This product is targeted for general air conditioning. Do not use this product in a situation where human life may be affected. If this product is used in clean rooms or places where reliability or control accuracy is particularly required, please contact Yamatake's sales representatives. Yamatake Building Systems Co., Ltd. bears no responsibility for any benefit, or lack of benefit, derived from the operation by the customer.

 **WARNING**

-  Disconnect power supply before beginning wiring to prevent electrical shock.
-  This product is not explosion-proof. Avoid atmospheres containing flammable (gasoline, etc.) or corrosive gases.
-  Do not dissolve this product except for removal of the cover for wiring or replacement of parts. Equipment damage or electrical shock may result.
-  Do not disconnect the actuator and valve while the power is switched on.

 **CAUTION**

-  Installer must be a trained, experienced service technician.
-  Check the ratings given in this instructions to prevent equipment damage.
-  Check the environment given in this instructions to prevent equipment damage.
-  Do not drop this product or apply excessive impact to prevent malfunction.
-  Do not stack boxes when storing products.
-  Do not use the motorized valve as scaffolding to prevent damage of the motorized valve or personal injury.
-  Prevent excessive operating cycle. It may shorten the life.
-  All wiring must comply with the applicable codes and ordinances.
-  Do not carry out wiring in rain or exposure to water splash.
-  Use crimp contacts with insulation jackets for wire terminals.
-  Check for loose wiring to prevent malfunction or equipment damage.
-  Do not incinerate this product at the time of disposal. Do not recycle all or a part of this product after disposal.

## Specifications

Item	Model No. MY9400xx001 / MY9402xx001 (Stroke 19 mm)	Model No. MY9401xx001 / MY9403xx001 (Stroke 38 mm)
Power supply	100 V AC $\pm$ 10 % (50/60 Hz) 200 V AC $\pm$ 10 % (50/60 Hz)	
Rated shift output	1334 N or more	
Rated operating time	42 sec (50 Hz), 35 sec (60 Hz)	41 sec (50 Hz), 34 sec (60 Hz)
Rated stroke	19 mm	38 mm
Feedback potentiometer	Resistance Normally 135 Maximum applicable voltage 13.5V DC	
Rated power consumption	100V AC: 22 W (50 Hz) / 23 W (60 Hz) 200V AC: 24 W (50 Hz) / 26 W (60 Hz)	100V AC: 48 W(50 Hz) / 50 W (60 Hz) 200V AC: 50 W(50 Hz) / 52 W (60 Hz)
Auxiliary switch (optional)	High/low limit no voltage output contact 250V AC - 5A (Resistive load), Approx. 3.5 A (Inductive load)	
LED display	ON while the torque limiter switch and high limit switch are operating (built-in)	
Insulation level	Type E (JIS C4004)	
Insulation resistance	Between power supply and housing	100 M or more / 500 V DC
Dielectric strength	Between power supply terminal and housing	1500 V AC / 1 min
Ambient operating condition	Rated operating condition Temperature: -25 to 55 °C Humidity: 10 to 90 %RH Vibration: 19.6 m/s <sup>2</sup> , 5 to 100 Hz Impact: 29.4 m/s <sup>2</sup>	Transport/storage condition Temperature: -25 to 70 °C Humidity: 10 to 95 %RH Vibration: 19.6 m/s <sup>2</sup> , 5 to 100 NHZ Impact: 294 m/s <sup>2</sup>
Protection	JIS C0920 Protection 5 (Equivalent to IP55)	
Installation orientation	Vertical to horizontal	
Manual operation	Use the detachable crank handle (attachment)	
Wiring port	G1/2 x 2 (with waterproof conduit)	Outer diameter of cable 9 to 11
Material	Aluminum die-casting	
Color	Baking silver metallic coating	
Weight	7.2 kg	7.0 kg
Attachment	Detachable crank handle (for manual operation)	
Auxiliary equipment (order separately)	Yoke set Model No.: QMY9400A1001 (Stroke 19 mm) QMY9400B1001 (Stroke 38 mm)	Components <ul style="list-style-type: none"> <li>• Yoke</li> <li>• Stem adaptor</li> <li>• Actuator installation bolt</li> </ul>

## Exterior Features

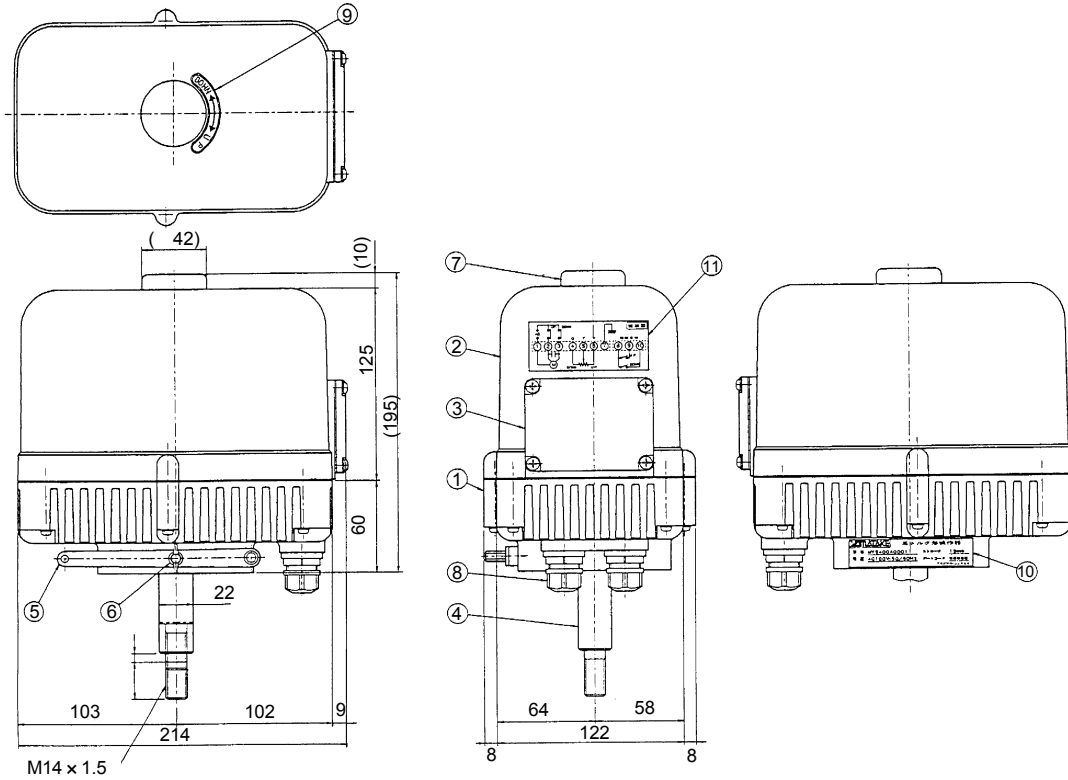

Figure 1 Dimensions (mm)

Name	Material
Base	Aluminum die-casting
Cover	Aluminum die-casting
Side cover	Aluminum die-casting
Output shaft	Stainless steel
Crank handle	Stainless steel
Wing bolt (M4X10)	Stainless steel
Crank handle shaft cap	NBR
Waterproof conduit	Nylon
Rotating direction seal	Polyester
Specifications plate seal	Polyester
Wiring diagram seal	Polyester

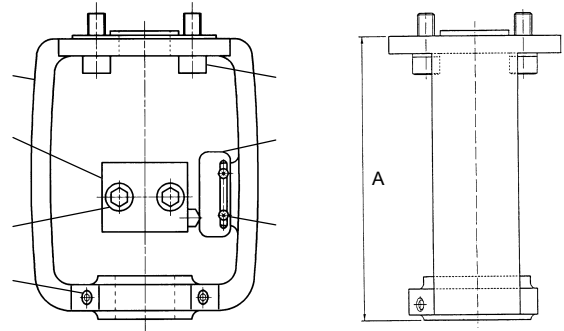

Figure 2 Yoke set

Actuator model No.	Yoke length A (Yoke set model No.)
MY9400 / MY9402 (Stroke 19 mm model)	164 mm (QMY9400A1001)
MY9401 / MY9403 (Stroke 38 mm model)	199.5 mm (QMY9400B1001)

Name	Material
Yoke	Gray iron
Fixing bolt	Stainless steel
Screw with hexagonal hole for mounting valve	Carbon steel
Stem adaptor (with pointer)	Carbon steel
Stem adaptor fixing bolt	Stainless steel
Scale plate	Stainless steel
Scale plate fixing screw	Stainless steel

## Installation Location

### ⚠ CAUTION

- ❗ Avoid acid gases that may corrode motor components or atmospheres containing explosive fumes.
- ❗ Avoid use in environments outside the allowable ambient temperature and humidity range.
- ❗ Avoid direct sunlight and constant water splash.

- 1) If installing this actuator outdoors, prevent exposure to direct sunlight.
- 2) Ensure not less than 20 cm clearance around this actuator to allow connection of wiring and manual operation.

## To connect valve and actuator

To connect the valve and actuator, order the yoke set separately.

This section explains how to connect valve and actuator.

### ⚠ CAUTION

- ❗ Check that the product number matches the specifications of the valve. An incorrect combination may damage the actuator or valve. Before shipment, the actuator is placed in the fully closed position (For a three-way valve, port B is closed). Install the actuator as-is.

Procedures 1 to 5 below should be carried out with the system switched off.

## Connection procedures

- 1 The bolt has a hexagonal hole (M10 x 25). Install the yoke on the actuator using a matching wrench. The actuator can be installed in any direction in 90-degree increments (Figure 3).

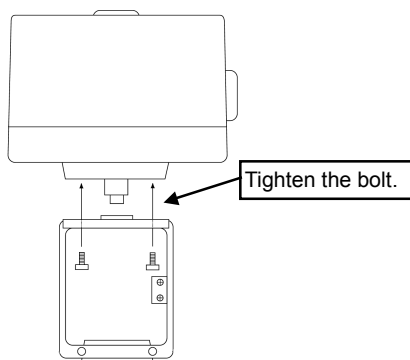

Figure 3

- 2 Push down on the stem of the valve to the lowest position (Figure 4) (two-way valve: fully closed, three-way valve: port B fully closed)

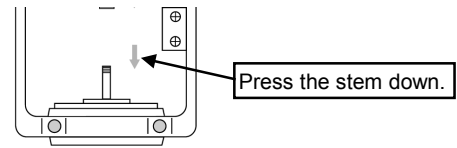

Figure 4

- 3 Connect the yoke combined with the actuator to the valve and anchor it using the hexagonal wrench (M5) in the hexagonal hole fixing screw (M8 X 25.2) (Figure 5).

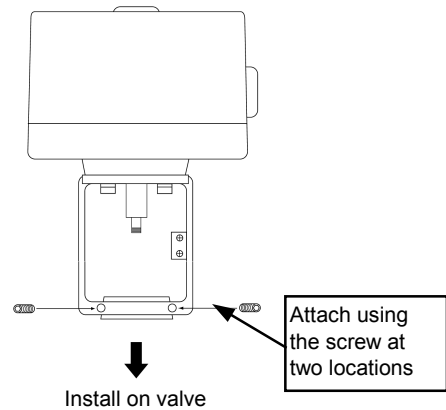

Figure 5

### ⚠ CAUTION

- ❗ If the actuator has shifted from the fully closed position (for a three-way valve, port B closed) as a result of manual operation or power being switched on, turn the actuator fully counter-clockwise using the crank handle, let it touch the mechanism stopper and then rotate it one turn clockwise to place it in the fully closed position.

- 4 Connect the actuator output shaft and valve stem using the stem adapter (Figure 6).

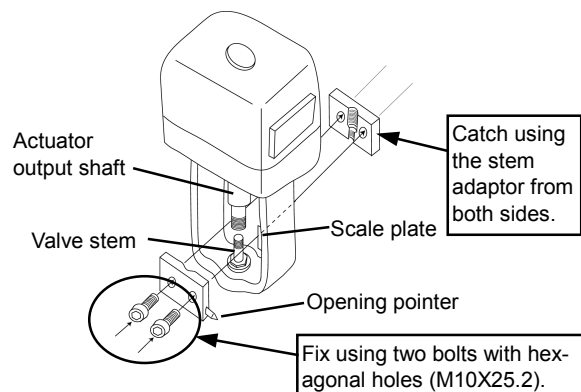

Figure 6

- 5 Adjust the position of the scale plate so that the valve opening pointer points to S on the scale plate. Loosen the screw fixing the scale plate on the yoke to move the scale plate.

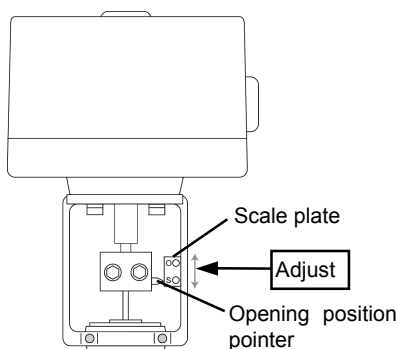

Figure 7

Connection of valve and actuator is now complete.

### Wiring Connection (Figure 8)

**⚠ CAUTION**

**!** Check that the model number of the actuator matches the power supply voltage. Use of an incompatible combination may damage the actuator.

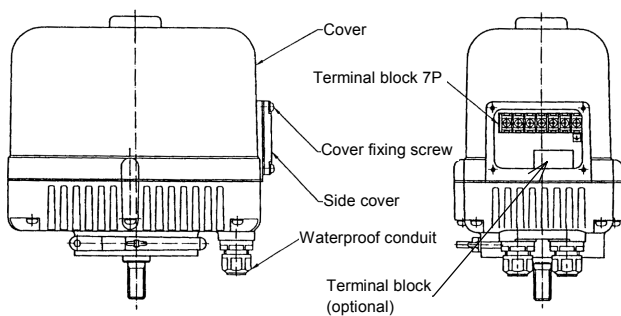

Figure 8 Wiring connections

- Remove the side cover and connect to the terminal block 7P (+ option terminal 3P).
- Check the wiring diagram to avoid incorrect connection.
- Use cables with an outside diameter of 9 to 11 which will fit inside the standard nylon resin waterproof conduit.

**⚠ CAUTION**

**!** After wiring, make sure to fully tighten the cover and conduit. If they are not fully tightened, damage may result.

Always install a protective fuse or circuit breaker on the power supply side. Refer to the following table for the capacity of the fuse and circuit breaker.

Model No.	Capacity of fuse and breaker	Power consumption*
MY9400/MY9402 (Stroke 19 mm)	100V AC	3A
	200V AC	3A
MY9401/MY9403 (Stroke 38 mm)	100V AC	3A
	200V AC	3A

\* At maximum output, +10 % of rated voltage

### Wiring (Figure 9)

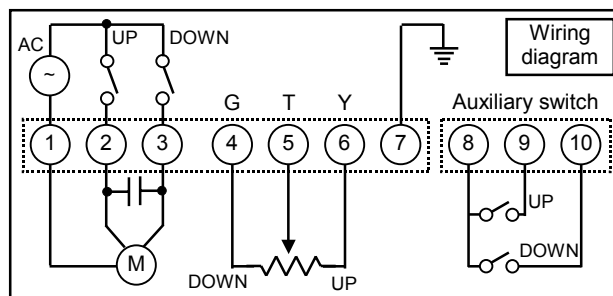

Figure 9 Wiring diagram

The earth terminal is No. 7 terminal.

The auxiliary switches (terminals 8, 9, 10) are optional (Model No. MY940XX1 only)

By using the auxiliary switches, the terminals 8 and 9 go on when the valve is fully open (for a three-way valve: port B open) and the terminals 8 and 10 go on when the valve is fully closed (for a three-way valve: port B closed). The maximum voltage applicable to the feedback potentiometer (terminals 4, 5, 6) is 13.5 V DC. If excessive voltage is applied, the potentiometer may be damaged.

**⚠ CAUTION**

**!** If two or more actuators are connected to one switch in parallel, they will not operate correctly and may be damaged.

### Operational check

After wiring, operate the actuator between the fully open position (three-way valve: port B open) and fully closed position (three-way valve: port B closed) and check that the actuator operates correctly as shown below.

- Manual operation: the actuator output shaft operates smoothly without being off-center or kinking.
- Motorized operation: The high and low limit LEDs go ON at the fully open and fully closed positions. (Refer to Figure 10.)

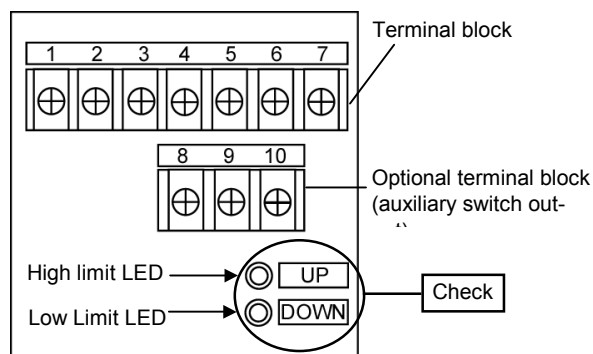





Figure 10 High/low limit LED

For actuators with options (MY940XX1), check that the auxiliary switch operates correctly.

## Manual operation (Figure 11)

 CAUTION	
	<p>Before manual operation, make sure that the power is turned off. If the actuator is operated manually with the circuit energized, the handle reverses the direction of rotation suddenly and may cause injury.</p>
	<p>Keep handle operation within the operation range. Exceeding the high/low operating limits may cause damage.</p>

- 1) Remove the rubber cap on the top of the cover and you can see through a hexagonal hole on the manual shaft.
- 2) Remove the attached handle, fixed with a wing bolt to the bottom of the actuator, and insert it into the hexagonal hole.
- 3) To move upward, turn clockwise. To move downward, turn counterclockwise (one turn moves the valve about 3 mm).
- 4) After manual operation is complete, replace the rubber cap.

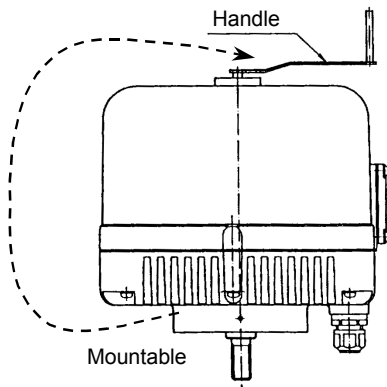

Figure 11 Manual operation

## Maintenance and Inspection



Carry out the following inspection about once every six months.

- 1) Use manual operation to check the valve opening position and the high and low limit positions of the actuator match (i.e. the shaft is free from eccentricity and moves smoothly).
- 2) Check that the actuator operates correctly using the external operation commands (Make sure that the motor stops at the high and low positions and the LED goes ON).

Periodic lubrication is not necessary.

To restart operation from long-term stop status, be sure to first carry out the following checks.

- (1) Turn the power off and operate the handle manually to check that the actuator does not operate off-center and moves smoothly.
- (2) Remove the cover and check that there are no problems such as condensation inside or incorrectly wired connections.

 CAUTION	
	<p>After inspection, make sure to tighten each cover fixing screw. Incomplete tightening may result in damage to the actuator.</p>

## Troubleshooting

Problem	Cause	Remedy
Motor does not operate.	Power is not ON.	Turn the power ON.
	A break in a wire or loose connection in a terminal block	Replace the wire and install the terminals correctly.
	Power voltage is incorrect or low.	Check the terminal voltage using a tester.
	Action of thermal protector (Ambient temperature is too high or valve load side is locked)	Reduce ambient temperature. Check the valve action under manual operation.
	The motor is faulty.	Replace the actuator

## Maintenance parts

- Yoke set
  - : QMY9400A1001 (For 19 mm stroke)
  - : QMY9400B1001 (For 38 mm stroke)
- For other maintenance parts, refer to the separate Maintenance Parts Price List.
- Stem adaptor
  - : 83163291-001 (For 19 mm stroke)
  - : 83163291-002 (For 38 mm stroke)

*Specifications are subject to change without notice.*

**YAMATAKE**

---

**Yamatake Corporation**  
**Building Systems Company**  
**International Business Headquarters**

Totate International Building  
1-12-19, Shibuya  
Shibuya-Ku, Tokyo, 150-8316  
URL:<http://www.yamatake.com>

Rev.1.1 Jly. 2001

Printed in Japan. AB-6015 2H-H (W)