

Control Motor Model MY3000

General

Control motor Model MY3000 actuates a control valve or a damper when combined with a linkage.

The following control motor types are available, classified by control method:

- (1) The control motor with built-in nominal 135 Ω feedback potentiometer exerting proportional control when combined with a digital controller (Model WY5111, etc.)
- (2) Nominal 135 Ω resistance input type exerting proportional control when combined with an electric proportional controller (Models TY9000, T991, etc.)
- (3) 4-20 mA DC input type exerting proportional control when combined with a digital controller (Model WY5111, Models R15, R35, R36, etc.)
- (4) 2-10 V DC input type exerting proportional control when combined with a digital controller (Model WY5117, etc.)
- (5) ON/OFF or floating type that exerts floating control when combined with a digital controller (Model WY7207, etc.)

When being combined with a control valve, this control motor is mounted with the Model Q455 valve linkage; when being combined with a damper, the control motor is installed with the Model Q605 damper linkage.



Features

- 1) A wide range of control input signal types are available.
- 2) The control motor features low power consumption and long service life.
- 3) The auxiliary switch is simple to install.
- 4) Valves and dampers in varied sizes can be actuated through the linkage.

















Safety Instructions

Please read instructions carefully and use the product as specified in this manual. Be sure to keep this manual nearby for ready reference.

Usage Restrictions

This product is targeted for general air conditioning. Do not use this product in a situation where human life may be affected. If this product is used in a clean room or a place where reliability or control accuracy is particularly required, please contact Yamatake's sales representatives. Yamatake Corporation will not bear any responsibility for the results produced by the operators.

CAUTION

-  • Installation must be performed by qualified personnel in accordance with all applicable safety standards.
-  • This product must be operated within its operating ranges specified in this manual. Failure to comply will cause equipment damages.
-  • Installation must be carried out under the operating conditions specified in this manual to prevent equipment damages.
-  • All wiring must comply with local codes of indoor wiring and electric installation rules.
-  • Always disconnect power source and product power supply before performing any wiring to prevent equipment damages.
-  • Use crimp terminals with insulation for electric wires.
-  • Make sure all the wires are tightly connected to prevent malfunctions.
-  • Do not disassemble at any time except when removing the cover to wire or when replacing a part. Equipment damages may occur.
-  • For storage, do not stack too many container boxes in which products are packed.
-  • Do not put any load on this product.
-  • This product may malfunction due to high temperature radiation. Do not install this product adjacent to a steam coil or to a high-temperature water coil.
-  • Avoid an instrumentation that keeps equipment operating cycle excessively frequent so as not to shorten the product operating life.
-  • When this product is combined with a third-party controller, please consult with our sales representative.
-  • Duty ratio of the operating time for the high-speed motor type needs to be 40 % or less.
-  • Do not incinerate this product for waste disposal. Do not recycle all or part of this product, either.
-  • Dispose of the product as an industrial waste complying with the local regulations.

Trademark information:

Inflex and Neostat are trademarks of Yamatake Corporation in Japan.

Specifications

Item	Specification		
Supply voltage	24 V AC \pm 15 %, 50 Hz/60 Hz or 100 V AC to 240 V AC (85 V AC to 264 V AC), 50 Hz/60 Hz		
Power consumption (Apparent power)	Model MY3000D0200 (24 V AC): Approx. 9 VA when operating, 0 VA when stopped. Model MY3000F0200 (24 V AC): Approx. 9 VA when operating, 0 VA when stopped. Model MY3000F0400 (24 V AC, high-speed type): Approx. 14 VA when operating, 0 VA when stopped. Models MY3000E0200, MY3000G0200, MY3000V0200 (24 V AC): Approx. 9 VA when operating, 4 VA when stopped. Model MY3000G9200 (85 V AC to 264 V AC): Approx. 14 W when operating, 4 W when stopped.		
Operating time	Models MY3000D0200, MY3000E0200, MY3000F0200, MY3000G0200, MY3000V0200 (24 V AC): 69 sec \pm 5 sec (50 Hz) / 58 sec \pm 5 sec (60 Hz) Model MY3000F0400 (24 V AC, high-speed type): 35 sec \pm 3 sec (50 Hz)/29 sec \pm 3 sec (60 Hz) Model MY3000G9200 (85 to 264 V AC): 72 sec (50/60 Hz) \pm 10 sec		
Control signal	Nominal 135 Ω feedback potentiometer [Max. applied voltage: 5 V DC] Nominal 135 Ω resistance input 4 mA DC to 20 mA DC input (Input impedance: 50 Ω \pm 5 %) 2 V DC to 10 V DC input (Input impedance: 1 M Ω or more) SPDT (Floating type)		
Environmental conditions		Rated operating conditions	Transport/storage conditions
	Ambient temperature	-20 °C to 60 °C	-20 °C to 70 °C
	Ambient humidity	5 %RH to 95 %RH	5 %RH to 95 %RH
	(Transport and storage conditions are applicable to the control motor in package.)		
Composition of major components	Case: Die-cast aluminum alloy Cover: Glass fiber-reinforced polycarbonate resin (Color: Gray) Bracket: Steel plate Chassis and the auxiliary chassis: Glass fiber-reinforced polycarbonate resin		
Surface treatment	Case: None Bracket: Electrogalvanization (Glossy chromate treatment)		
Installation location	Indoors Outdoors (When installed outdoors, the control motor must be protected by its cover. Avoid locations susceptible to salt damage and corrosive gases and exposed to direct sunlight.)		
Mounting angle	Ranging from upright to sideways (inclined to 90°), the control motor can be installed in any angle. (See Fig. 3.) (It must be installed upright for outdoor use.)		
Wiring	On the installation site, punch out the required knockout hole (ϕ 22 mm) on either side of the control motor, and perform wiring to the terminal block with screws.		
Enclosure rating	Equivalent to IEC IP54 (Dust-proof and splash-proof) (IEC:International Electrotechnical Commission)		
Insulation resistance	Between terminal and case: 5 M Ω or higher / 500 V DC		
Withstand voltage	24 V AC power type (Floating type, nominal 135 Ω feedback potentiometer type) Between terminal and case: 500 V AC/1 min. 24 V AC power type (Nominal 135 Ω resistance input type, 4-20 mA DC input type, 2 V DC to 10 V DC input type) Between terminal and case: 500 V AC/1 min. 85 V AC to 264 V AC power type (4 mA DC to 20 mA DC input type) Between terminal and case: 1500 V AC/1 min.		
Motor shaft position for factory shipment	The control motor is shipped with the shaft turned fully counterclockwise.		
Weight	Approx. 3 kg		
Accessories	Hex bolt M6 \times 25 (for Model Q605 damper linkage)		
Optional equipment (Separate order required)	Model AT72-J1 power transformer Primary side: 100 V AC/200 V AC/220 V AC Secondary side: 23 V AC (for the rated load), 23 VA.		
Order requirement	Model number (Refer to the table "Model Number Specifications".) Linkage (Model Q455 valve linkage / Model Q605 damper linkage)		

Optional equipment

Water seal connector Part No. 83104346-003	Applicable wire dia.: $\phi 7$ mm to $\phi 9$ mm (Required for splash-proof enclosing purpose.)
Auxiliary switch Part No. 83165271-004	4 switches are built in. Max. applied voltage and current: 30 V DC, 3A; 250 V AC, 5 A (resistive load), 3 A (inductive load) Operating position: Adjustable between 5 % (fully closed) to 95 % (fully open). Each switch is set by the setting dial A, B, C, or D.

Optional items (Separate order is required):

1. Model AT72-J1 power transformer
Primary side: 100/200/220 V AC. Secondary side: 23 V AC, 23 VA
2. Model Q455 valve linkage
3. Model Q605 damper linkage

Model Number Specifications

Model number	Product specification							
	Supply voltage	Input signal	Angular stroke	Operating time for one stroke		Output torque	Remarks	Auxiliary switch
				50 Hz	60 Hz			
MY3000D0200	24 V AC	SPDT floating	160°	69 sec	58 sec	12.5 N·m	ON/OFF operation	Installed as optional equipment
MY3000E0200	24 V AC	Nominal 135 Ω resistance input						
MY3000F0200	24 V AC	Nominal 135 Ω feedback potentiometer						
MY3000G0200	24 V AC	4 mA DC to 20 mA DC						
MY3000V0200	24 V AC	2 V DC to 10 V DC						
MY3000G9200	85 V AC to 264 V AC	4 mA DC to 20 mA DC		72 sec				
MY3000F0400	24 V AC	Nominal 135 Ω feedback potentiometer		35 sec	29 sec	6 N·m	High-speed motor type*	

*Duty ratio of operating time for high-speed motor type must be 40 % or less.

Dimensions

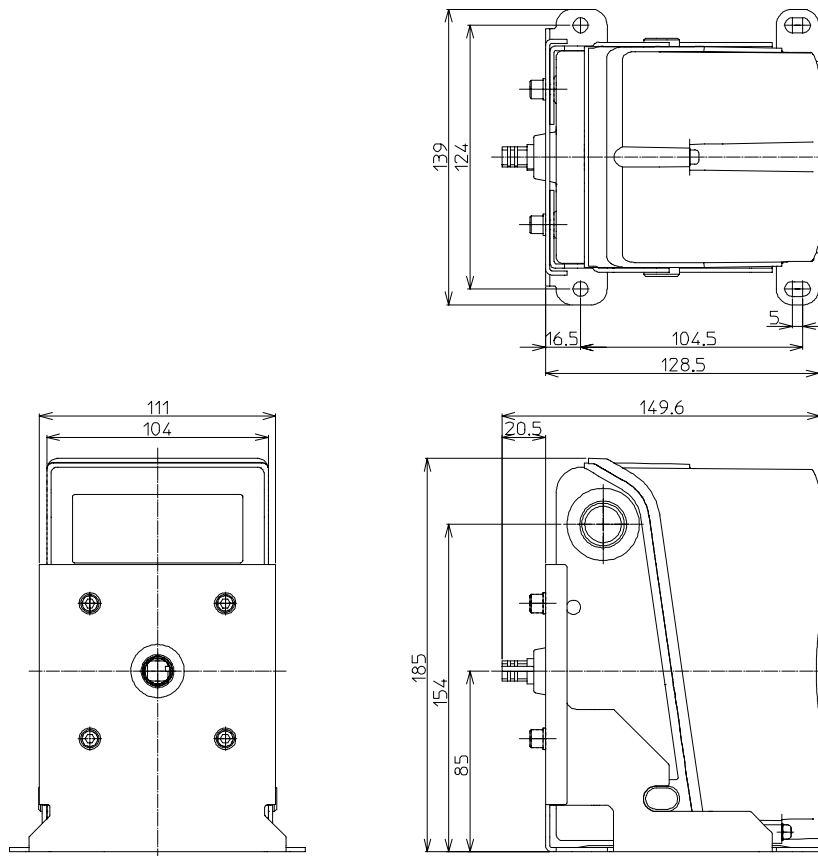

Figure 1. Dimensions (mm)

Parts Identification

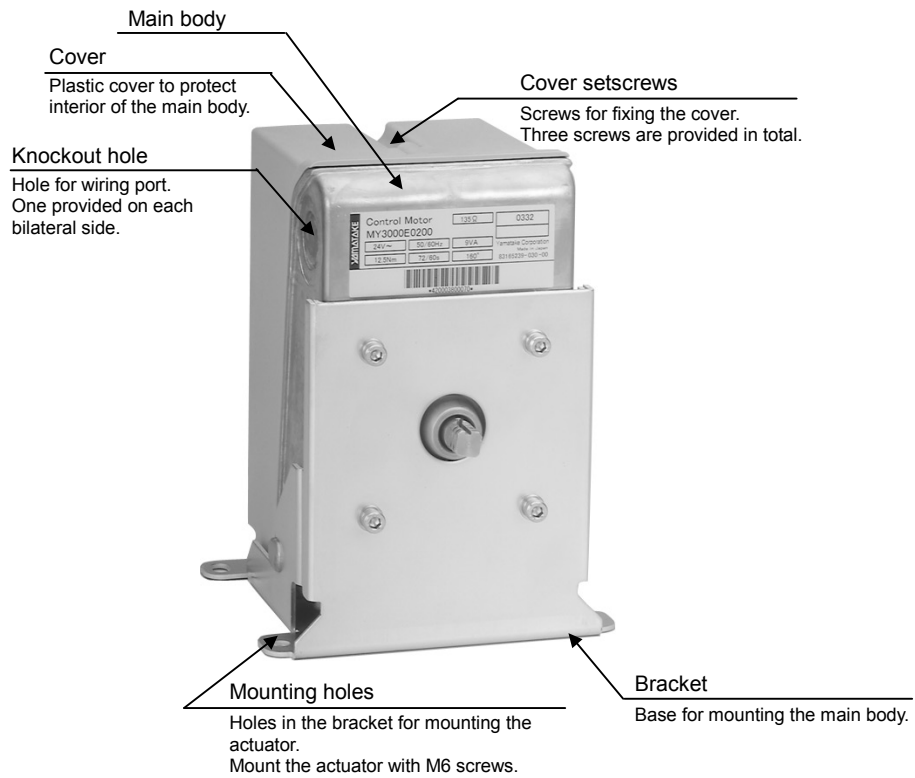

Figure 2. Parts identification

Installation Precautions

Atmosphere

⚠ CAUTION	
!	• Avoid using the control motor in an atmosphere containing acid gases and explosive gases that may corrode the control motor components.
!	• Chemicals, organic solvents, and their vapors may corrode the cover. Avoid wiping the control motor with them. Do not use the control motor in an atmosphere containing chemicals or solvents.
!	• Extreme heat may result in control motor malfunction. Do not install the control motor adjacent to steam coils, high temperature water coils, or the like.

Installation

The control motor can be installed at any angle from up-right to sideways based on the output shaft. Do not mount the control motor with the output shaft pointing upward.

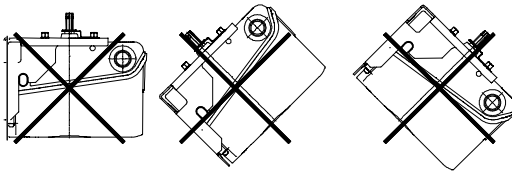

Figure 3. Incorrect mounting angles

When using with control valves:

If the Model MY3000 control motor is combined with a control valve (Model V5063A, V5064A, V5065A, or the like.), use the Model Q455C or Q455D valve linkage. To install the linkage, refer to AB-4051 Specifications/Instructions.

When using with dampers

If the Model MY3000 control motor is combined with a damper, use the Model Q605 damper linkage. To install the linkage, refer to AB-4062 Instructions/Specifications.

The crank arm to be assembled to the main shaft of the control motor comes attached to the Model Q605 damper linkage. To assemble the Model MY3000 to the damper linkage, use the M6 screws supplied with the control motor. Tighten the M6 screws with the M6 nuts supplied with the damper linkage.

Wiring

⚠ CAUTION	
!	• To avoid electric shock, always disconnect the power supply when performing any wiring.
!	• To avoid malfunctions and accidents, never apply a voltage higher than the rated of the control motor.
!	• To avoid malfunctions, do not remove the cover except when wiring.

Wiring precautions

- 1) Never apply a voltage higher than 5 V to the terminals ④, ⑤ and ⑥. (See Fig. 4.)
- 2) To perform wiring, a knockout hole for wiring port on the control motor must be cut out. A $\phi 22$ mm knockout hole is provided on each bilateral side of the terminal block. Select the knockout hole on the appropriate side, based on the mounting directions for the conduit pipe or connector, then gently knock the hole with a screwdriver. (See Fig. 2.)
- 3) For wiring, detach the cover by removing the three cover setscrews. (See Fig. 2.)
- 4) Wiring is connected to the terminals (M3.5 screws) of the control motor. Connect the wires by referring to the layout of the terminal block shown in Fig. 4, the wiring terminal diagrams shown in Figs. 10 to 14, and the examples of wiring connections shown in Figs. 15 to 18.
- 5) If the control motor is installed outdoors or in very humid environments, use the water-proof connector or the like. $\phi 22$ mm knockout holes are on bilateral sides (one for each). Select the appropriate one. (See Fig. 2.)
- 6) After wiring, replace the cover and fix with the cover setscrews. (See Fig. 2.)

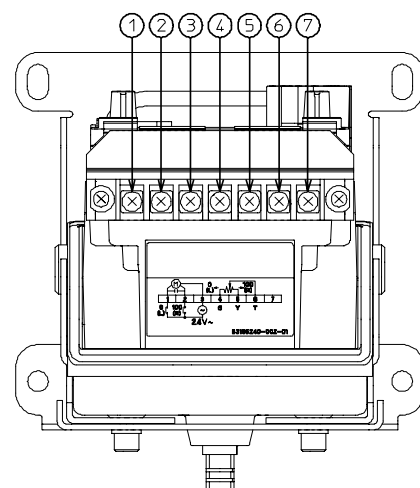

Figure 4. Layout of the terminal block with the cover removed

For splash-proof enclosure ...

- 1) Be sure to close the cover, inspecting that no packing or cable is caught underneath.
- 2) Waterproof the wiring port.
 - When pulling out the cable through the wiring port, use a water-proof connector
Recommended product:
Water seal connector (Part No. 83104346-003)
 - If the cable connection is made through a conduit pipe, use a water-proof plica tube or other appropriate tubes.

Auxiliary switch (Optional)

CAUTION	
	• The auxiliary switch is an optional item. It should be installed at the installation site.
	• Do not apply external force on the control motor. (e.g. Placing an object on the cover.)

■ Auxiliary switch

1. Content of package

- Auxiliary switch unit: 1 set
- Screws (M3 × 6): 2
- Wiring label: 1

2. Specifications

1) Contact rating

- 250 V AC, 5 A (Resistive load)
- 3 A (Inductive load)

2) Built-in switches: 4

3) Terminal block

Three terminals are provided for each switch:

- ① Common terminal
- ② NO (normally open) terminal
- ③ NC (normally closed) terminal

Fig. 5 indicates the relationships between the terminals and the switches.

4) Switch operating position

The switches operate when the arrows of the setting dials (A, B, C, and D) point at the position with ► marked. For setting the switches, refer to 5) and 6).
Output opening range can be set from 5 to 95%.
Repeatability of operating position: Within ± 3%.
After setting, always confirm that the switches operate before the control motor is fully closed or opened.

5) Switch operating method

When the output opening outreaches the preset opening, the contact between terminals 1 and 2 makes (NO), while the contact between terminals 1 and 3 breaks (NC). (See Fig. 5.)

Fig. 5 shows a setting example of ON between the terminals 1 and 2 / OFF between the terminals 1 and 3 at 50 % opening during the opening operation.

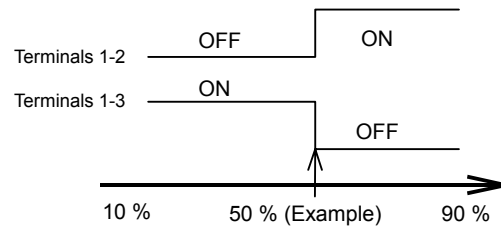

Figure 5. Example of auxiliary switch contact operation

6) Setting of the auxiliary switch operating position (Fig. 6 shows a setting example of the switch operating at a 50 % open position.)

- (1) Set the setting dials of the auxiliary switch to the position where you want the switch to operate, by motor-driven operation. Then, using a slotted screwdriver, turn the setting dial until its arrow points at the the position with ► marked. (See Fig. 6.)
- (2) Operate (open and close) the control motor several times near the preset position to confirm that the switch works normally.

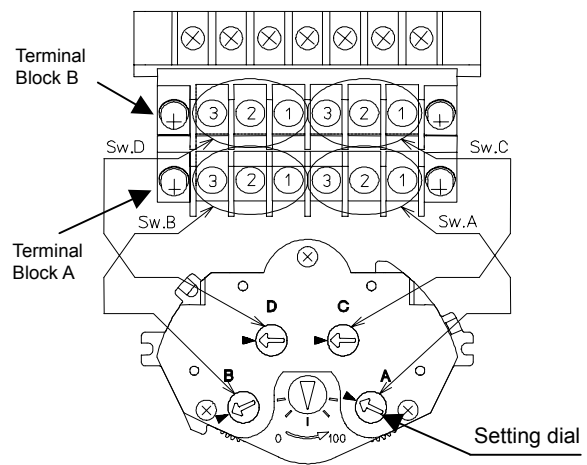



Figure 6. Setting example of the auxiliary switch with its position set to 50 %

3. Assembling/disassembling the auxiliary switch

 CAUTION
 <ul style="list-style-type: none"> Disconnect the power supply before assembling or disassembling the auxiliary switch unit.

- Assembling the switch unit (See Figs. 7 and 8.)
 - Break the parts A (of the chassis) and B (of the auxiliary chassis).

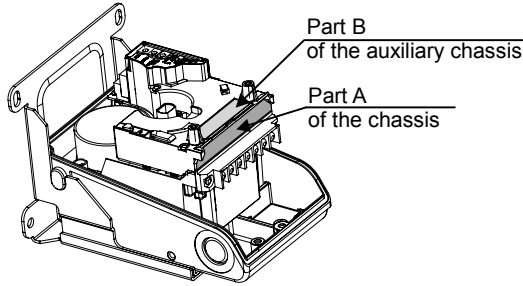

Figure 7. Parts to be removed for mounting the auxiliary switch

- Insert the shaft of the auxiliary switch unit into the shaft of the control motor. (Align the tip of the arrow to the graduation side.) <Step 1 in Fig. 8>
- Turn the auxiliary switch unit counterclockwise until it clicks. <Step 2 in Fig. 8>
- Align the holes of the fixtures of the terminal block with the screw holes on the auxiliary chassis. <Step 3 in Fig. 8>
- Fix the terminal block with the two screws. <Step 4 in Fig. 8>

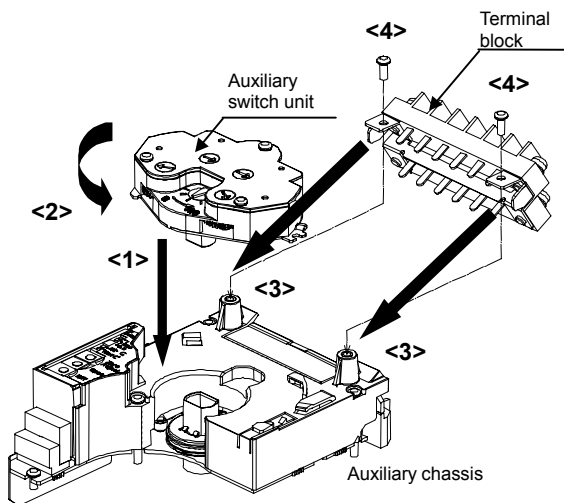

Figure 8. Assembling the auxiliary switch unit

- Disassembling the switch unit (See Fig. 9)
 - Remove the two screws. <Step 1 in Fig. 9>
 - Detach the terminal block. The terminal block and fixtures are integrated in one unit. <Step 2 in Fig. 9>
 - Turn the auxiliary switch unit clockwise <Step 4 in Fig. 9> while pressing the button <Step 3 in Fig. 9>.
 - Lift and remove the unit. <Step 5 in Fig. 9>

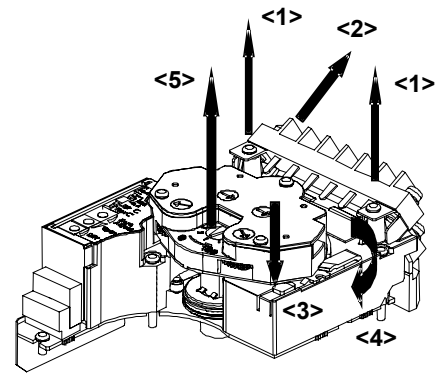
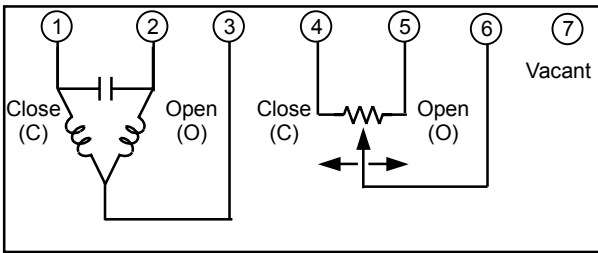

Figure 9. Disassembling the auxiliary switch unit

Wiring Terminals



Model MY3000F

Figure 10. Wiring terminal diagram
(Model MY3000F with nominal 135 Ω feedback potentiometer)

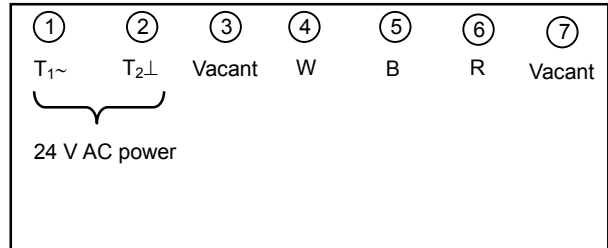

Model MY3000E

Figure 11. Wiring terminal diagram
(Model MY3000E with nominal 135 Ω resistance input)

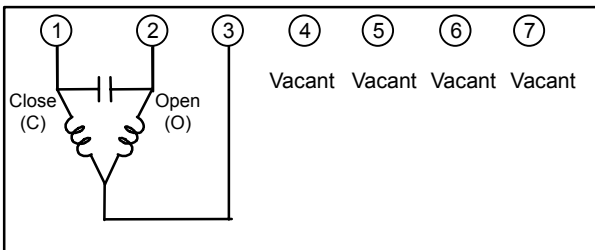

Model MY3000D

Figure 12. Wiring terminal diagram
(Model MY3000D with floating)

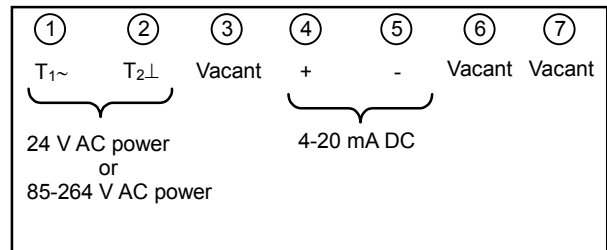

Model MY3000G

Note: Terminals 2 ($T_{2\perp}$) and 5 (-) are not connected inside of the control motor.

Figure 13. Wiring terminal diagram
(Model MY3000G with 4-20 mA DC input)

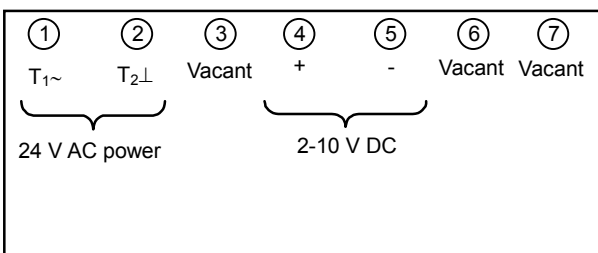

Model MY3000V

Note: Terminals 2 ($T_{2\perp}$) and 5 (-) are not connected inside of the control motor.

Note: For common line application (one line used for 24 V AC power and 2-10 V DC input), be sure to externally connect terminals 2 and 5.

Figure 14. Wiring terminal diagram
(Model MY3000V with 2-10 V DC input)

Examples of Wiring Connections

• Connection to Infilex™ GC

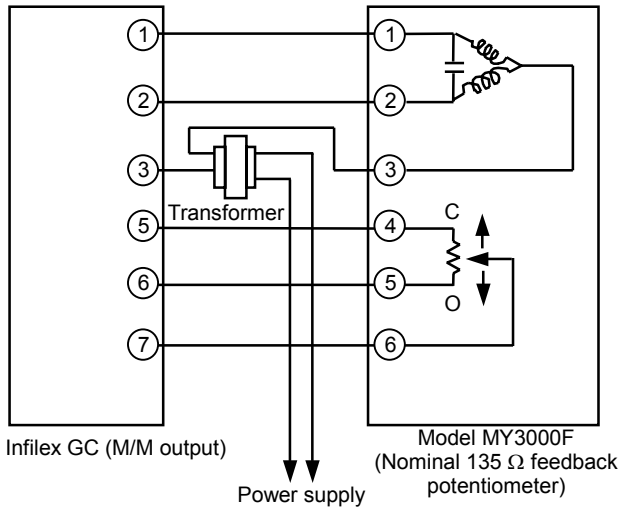

• Connection to Neostat™ (Model TY9000)

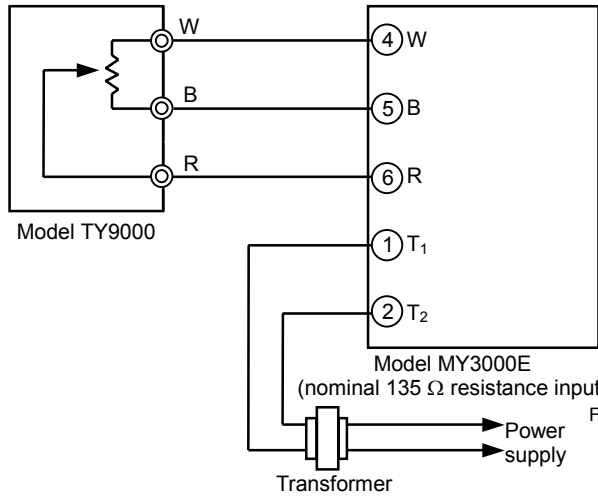

• Connection for interlocking of Model MY3000E (nominal 135 Ω resistance input) (24 V AC type)

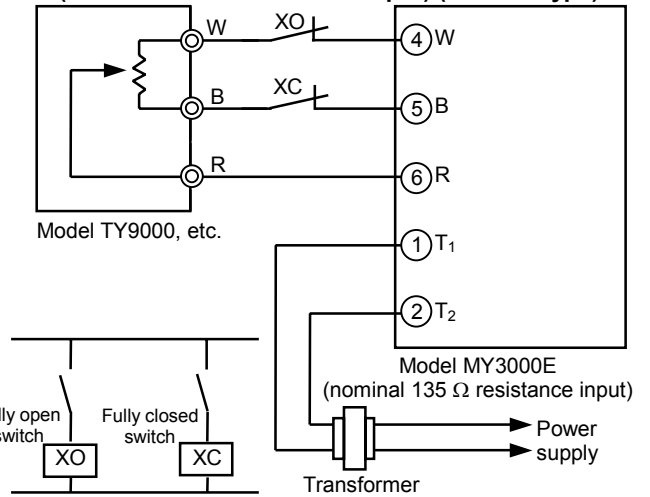

• Connection for Model MY3000E (nominal 135 Ω resistance input) with summer-winter changeover (24 V AC type)

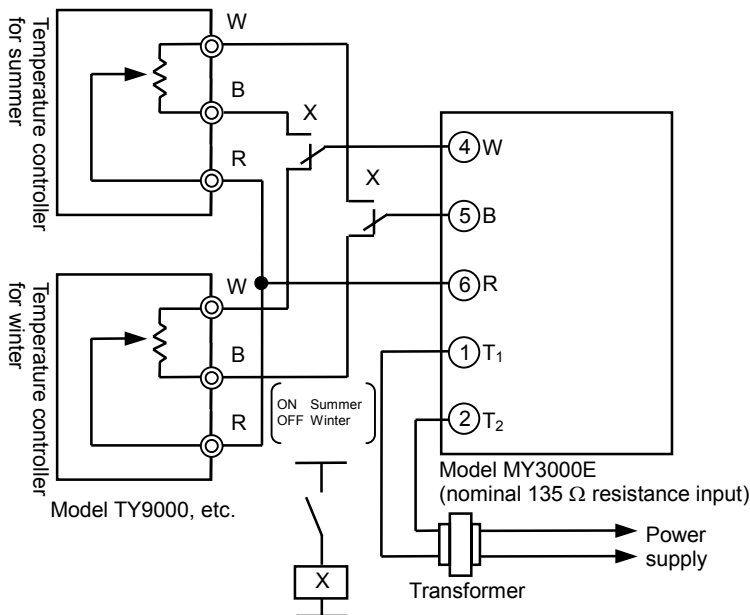

XO: 100 % when opened
XC: 0 % when opened

- Notes:
- Connect directly between each R of the controllers and R of the actuator.
 - The current between Ws, Bs and Rs is 5 mA or higher. For relay, use Model HH54P manufactured by Fuji Denki or equivalent.
 - Min. load of relay contact: Max. 10 V, 1 mA
 - Max. load of relay contact: Min. 20 V, 20 mA

Figure 15. Examples of wiring connections to Infilex GC, to Neostat, for Interlocking, and for summer/ winter changeover

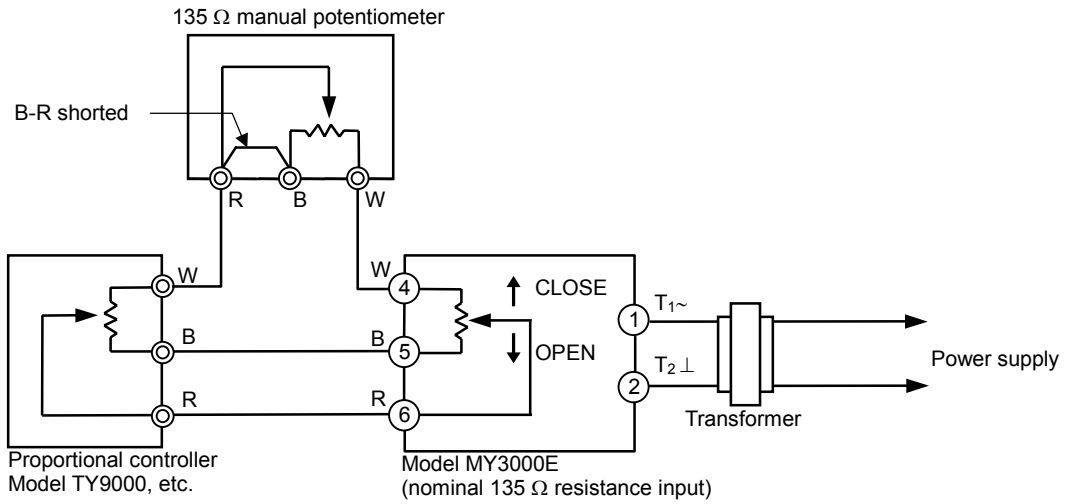

- Using a 135 Ω manual potentiometer with a proportional controller allows to set the minimum open position.
- The minimum open position can be fixed at a value within the range from 0 to approx. 100 %, depending on the value to be set.

Figure 16. Examples of wiring connections for min. open position setting (nominal 135 Ω resistance input)

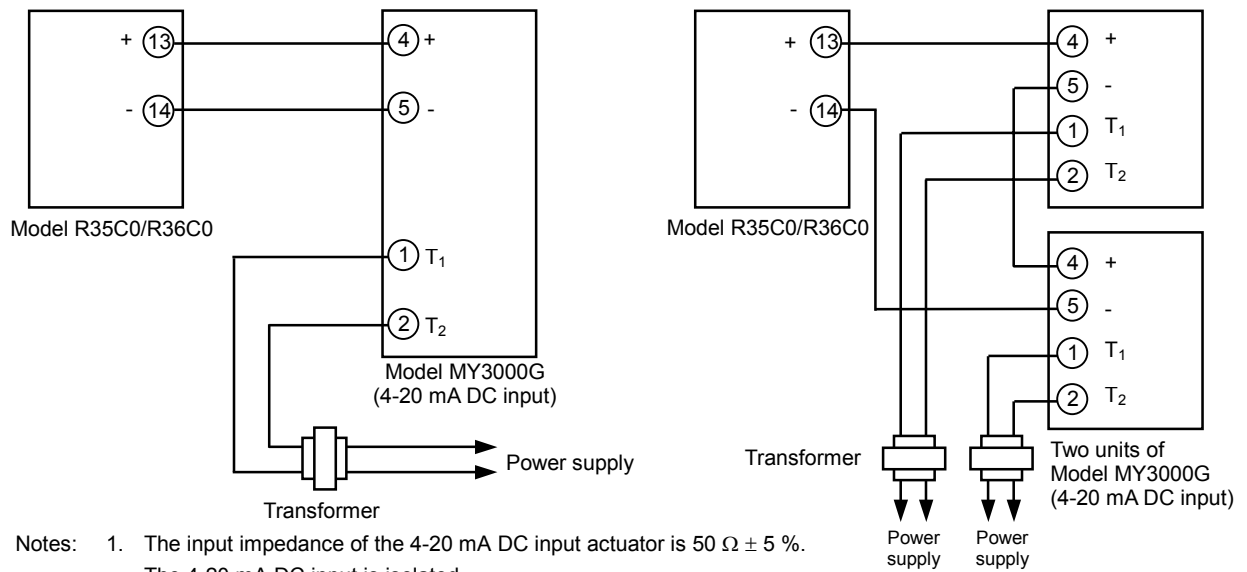

- Notes:
1. The input impedance of the 4-20 mA DC input actuator is $50 \Omega \pm 5 \%$. The 4-20 mA DC input is isolated.
 2. Terminals 2 (T₂) and 5 (-) are not connected inside of the actuator.

Figure 17. Examples of wiring connections to Model R35C0/R36C0

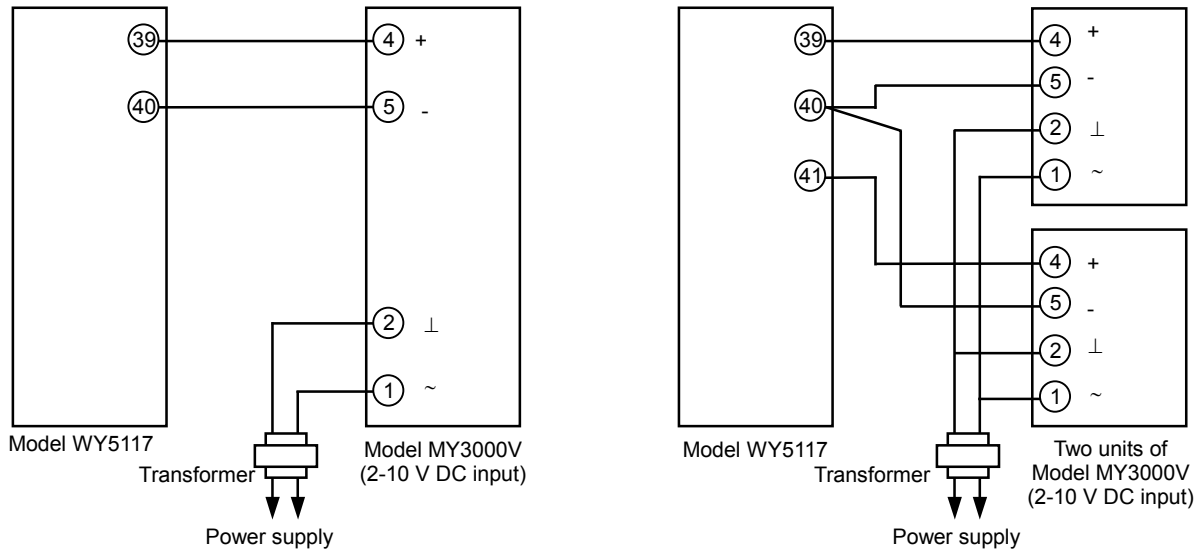

- Notes:
1. Terminals 2 (T₂) and 5 (-) are not connected inside of the actuator. The input impedance of the actuator with 2-10 V DC input is 1 MΩ or higher.
 2. Avoid parallel wiring that passes through the power supply terminal of the actuator.

Figure 18. Examples of wiring connections to Inflex AC

Inspection and Maintenance

1) Inspection

Inspect the control motor according to Table 1.

If the control motor has been inactive for an extended period of time after installation, operate (open and close) the control motor once or twice before using it.

2) Maintenance

Visually inspect the control motor operations every six months or so. If you observe any of the problems indicated in Table 2, take the corresponding actions.

Table 1. Inspection items and details

Inspection item	Inspection interval	Inspection detail
Visual inspection	Semiannual	<ul style="list-style-type: none"> Loosened bolts Actuator damages
Operating status	Semiannual	<ul style="list-style-type: none"> Unstable operation Abnormal noise or vibration
Routine inspection	Any time	<ul style="list-style-type: none"> Abnormal noise or vibration Unstable operation Hunting

Table 2. Troubleshooting

(If the actions indicated below do not resolve your problem, please consult Yamatake's service personnel.)

Problem	Part to Check	Action
<ul style="list-style-type: none"> The control motor does not operate. 	Wiring condition / Disconnected wires	Check the wiring.
<ul style="list-style-type: none"> The control motor stops halfway. 	Loosened terminal connection	Tighten the terminals.
<ul style="list-style-type: none"> The auxiliary switch does not operate. 	Auxiliary switch (cam switch) condition Wiring condition / Disconnected wires	Redo the cam switch setting. Check the wiring.
<ul style="list-style-type: none"> Control sensitivity is degraded. Actuator torque is decreased. 	Wiring condition / Disconnected wires Loosened terminal connection Actuator power supply voltage	Check the wiring. Tighten the terminal. Adjust the supply voltage (except 85 to 264 V power supply types).



Specifications are subject to change without notice.

Yamatake Corporation
Building Systems Company

<http://www.yamatake.com>

Rev. 2.0 Aug. 2005
(J: AI-6387 Rev. 1.2)

AB-6387 0.5H-H (W00)
Printed in Japan