



Gas Flow Monitor CMG Series

**Superb Capability for
Air Ratio Control and Energy
Management of
Individual Burners**

The CMG series gas flow monitor is a compact, high-accuracy mass flow meter equipped with Yamatake's μ F (Micro Flow) sensor chip. It accurately measures the mass flow rate at 0°C and one atmospheric pressure, with no effect against changes in temperature and pressure. The CMG series offers a wide range of functions, such as instantaneous and integrated flow rate indication, and event output and analog output. In addition to its wide rangeability, the CMG series is available in a variety of models for application to city gas 13A (LNG), air, butane and propane gases. It also supports air ratio control and energy management of burners.





Gas Flow Monitor

City gas 13A (LNG), air, butane and propane gases

- A wide range of models available
- Low pressure loss makes it suitable in a wide range of burner applications



High-accuracy, high-speed response measurement

The CMG series equipped with Yamatake's Micro Flow (μF) sensor realizes a compact body and high accuracy of $\pm 4\%$ RD. It also eliminates the need for correction of measured values generally affected by changes in temperature and pressure, due to its method of mass flow measurement.

Easy gas flow measurement and management

The CMG series' digital indication of instantaneous / integrated flow rate is visible from a distance, and its measurement status can be indicated by Hi, Lo, OVER, ALARM LEDs.

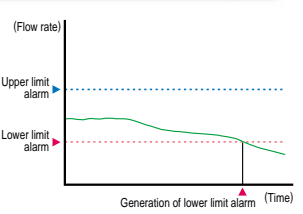

Other functions, for example, setting the upper limit and lower limit alarms, and using contact and analog signals as external outputs, are effective for flow management, such as monitoring quantity of fuel used.

Most suitable for burner applications

Because of its structure to minimize pressure loss, the CMG series is the most suitable for burner applications that are sensitive to pressure loss.

Free directions for mounting and indication in any direction

Unlike conventional controllers, the CMG series does not require straight piping at upstream and downstream sides.* Indication direction can also be changed, allowing easy mounting in any direction. (* Refer to Precautions item 5)

Compact body with IP54 protective structure

With a compact mask of 83.9X83.9mm and protective structure of IP54(JIS C 0920), the CMG series can be installed without restrictions.

Self-diagnosis function

The self-diagnosis function is effective for troubleshooting.

Proposing a next-generation gas flow meter

The application of a μF (Micro Flow) sensor chip has enabled the development of a compact, high-accuracy gas flow meter.

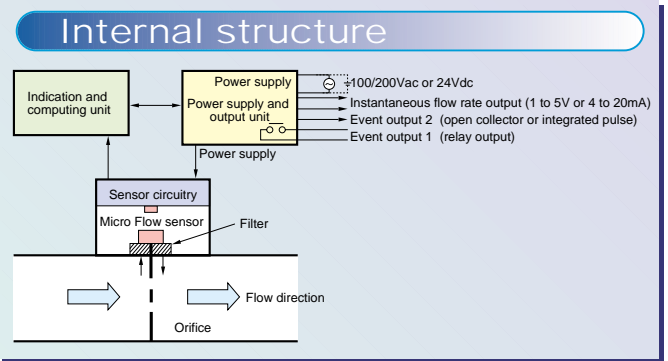

Excess air ratio

The amount of air needed for complete combustion is theoretically determined, and referred to as theoretical quantity of air. However, in actual combustion equipment, the theoretical quantity of air is insufficient for complete combustion. Therefore, excess air is used in order to sustain stable combustion and minimize heat loss due to exhaust gas, CO and particulate.

$$\text{Excess air ratio (m)} = \frac{\text{Quantity of air used (A)}}{\text{Theoretical quantity of fuel (AO)}}$$

Excess air ratio is generally set at $m=1.1$ or higher by burner adjustment. From knowing the gap in excess air ratio caused by dirt and dust on the burner and filter, the burner can be adjusted to realize optimum air ratio as well energy savings. According to energy conservation laws, the reference and target values of air ratio for energy saving are determined for each equipment.

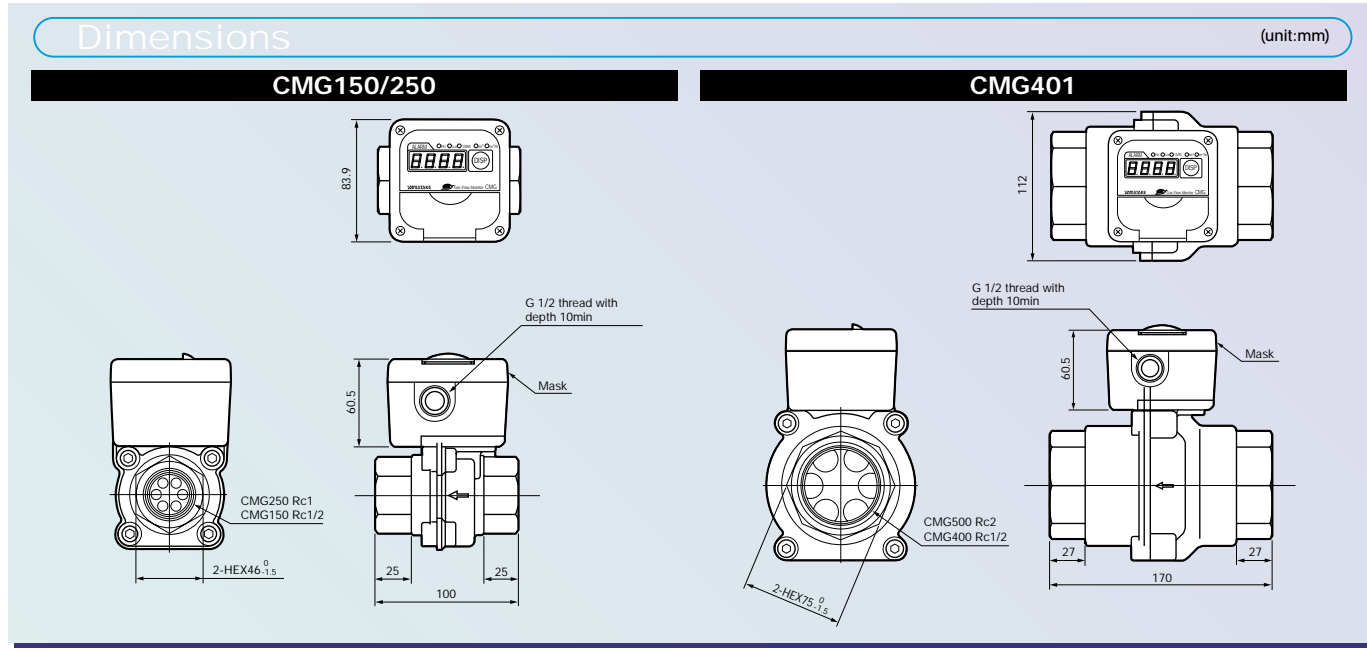
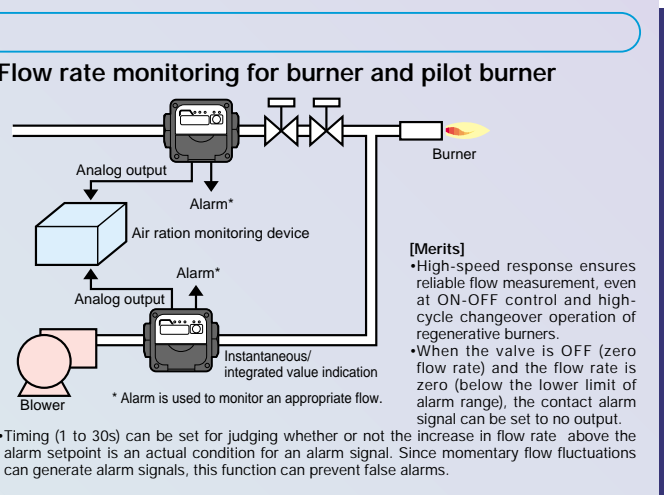
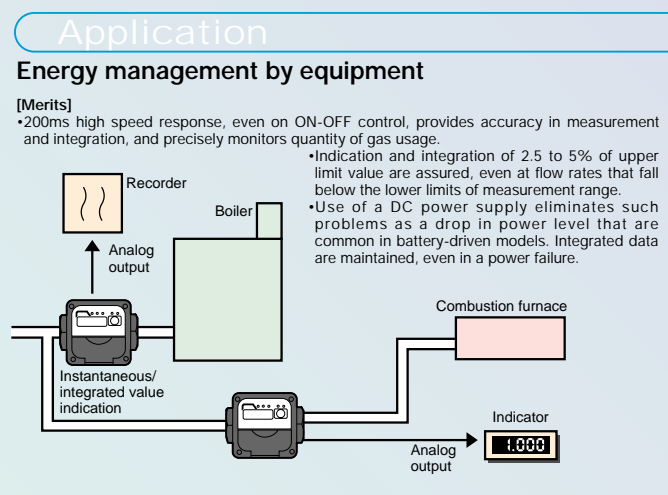

- ### Precautions
1. Install this unit at the upstream side of safety shutoff valve in the gas flow piping line. Explosive gases mixed with air should not enter the piping, as a lighting discharge causes sparks to ignite and an explosion might occur. In case of applied excessive voltage or a power short-circuit, the unit is protected by an internal safety circuit and fuse.
 2. This unit is designed for gas and air as indicated by model number. Do not use for any other gases. If this unit is used for a gas of which ignition temperature is lower than that of the indicated gas, and if an explosive gas mixed with air enters the piping, an explosion might occur due to the built-in heater in the sensor.
 3. The use of a strainer is required in the gas flow line on the upstream side of this unit to prevent rust occurring or foreign matter entering. If a foreign matter enters the piping, an operation failure might occur.
 4. If this unit is used outdoors, protection from direct sunlight and rain is needed.
 5. The CMG250 (30m³/h(normal) type) and CMG400/500 series have a larger hole in the main flow orifice to enable larger flow. Therefore, if there is no straight piping area, the flow rate in the bypass becomes unstable, resulting in a decline of accuracy of 8 to 10%. In order to maintain 4% accuracy, the inlet side straight pipe length must be 15cm or longer for the CMG250 (30m³/h(normal) type) and 10cm or longer for the CMG400/500 series.

Specifications

City gas 13A (LNG) and air models

Model No.	CMG 150	CMG 250	CMG 400/401	CMG 500/501
Measurement range (m ³ /h(normal))	0.5 to 4.0	1.0 to 10.0	8.0 to 80.0	15.0 to 150.0
Indication range (m ³ /h(normal))	0.0 to 7.0	0.0 to 16.0	0.0 to 100.0	0.0 to 170.0
Power consumption	AC model: 2W max., DC model: 5.5W max.			
Indication accuracy (Instantaneous flow rate)	±4%RD±1 digit (10 to 40°C) ±6%RD±1 digit (-10 to +60°C)		±4%RD±1 digit (10 to 40°C) ±6%RD±1 digit (0 to 50°C)	
Event outputs 1 and 2	Event output 1: Contact closes at alarm generation, Event output 2: NPN open collector			
Applicable pressure	100kPa max.		100kPa max. (low pressure model) 990kPa max. (medium pressure model)	
Straight piping length	(No need)	(No need)	15cm min.	10cm min. 40cm min. 10cm min. 40cm min.
Protection	IP54 (JIS C 9020)			
Mask color	City gas model: Yellow, Air model: Blue			
Approx. weight	850g	800g	2.1kg, (Flange model 9kg)	2kg, (Flange model 10kg)

Notes: %RD: Percentage to output reading, m³/h(normal): Volume flow per hour converted to the conditions of 0°C and 1 atmospheric pressure.

Butane and propane models

Model No.	CMG 150	CMG 250	CMG 400	CMG 500
Measurement range (m ³ /h(normal))	0.20 to 2.00	0.4 to 4.00	1.00 to 10.00	2.5 to 25.0
Indication range (m ³ /h(normal))	0.1 to 1.00	0.30 to 3.00	0.8 to 8.00	2.0 to 20.0
Indication range (m ³ /h(normal))	0.00 to 3.00	0.00 to 6.00	0.00 to 12.00	0.0 to 30.0
Indication range (m ³ /h(normal))	0.00 to 1.50	0.00 to 4.50	0.00 to 10.00	0.0 to 45.0
Power consumption	AC model: 2W max., DC model: 5.5W max.			
Indication accuracy (Instantaneous flow rate)	Instantaneous flow rate: ±6%RD±1 digit (10 to 40°C)			
Event outputs 1 and 2	Event output 1: Contact closes at alarm generation, Event output 2: NPN open collector			
Applicable pressure	100kPa max.			
Straight piping length	(No need)	(No need)	15cm min.	10cm min. 40cm min. 10cm min. 40cm min.
Protection	IP54 (JIS C 9020)			
Mask color	Yellow			
Weight (approx.)	850g	800g	2.1kg	2kg

Notes: 1. %RD: Percentage to output reading, m³/h(normal): Volume flow per hour converted to the conditions of 0°C and 1 atmospheric pressure.

- Butane gas composition: 75% butane and 25% propane
- Propane gas composition: 98% propane and 2% butane

City gas 13A (LNG) and air models

Example: CMG150A004000100

Table	Selection	Description
I	Basic model No.	Gas flow meter
II	Piping size	15 ↓ ○ ○ ○ ○ ○ 15A (1/2B)
		25 ○ ○ ○ ○ ○ 25A (1B)
		40 ○ ○ ○ ○ ○ 40A (1.5B)
		50 ○ ○ ○ ○ ○ 50A (2B)
III	Piping size	0 ○ ○ ○ ○ ○ Rc thread
		1 ○ ○ ○ ○ ○ JIS 10K flange
IV	Gas type	A ○ ○ ○ ○ ○ Air
		N ○ ○ ○ ○ ○ City gas 13A (LNG)
V	Flow range	004 ○ ○ ○ ○ ○ 4 m ³ /h(normal)
		010 ○ ○ ○ ○ ○ 10 m ³ /h(normal)
		030 ○ ○ ○ ○ ○ 30 m ³ /h(normal)
		080 ○ ○ ○ ○ ○ 80 m ³ /h(normal)
		150 ○ ○ ○ ○ ○ 150 m ³ /h(normal)
VI	Output	0 ○ ○ ○ ○ ○ 1 to 5Vdc
		1 ○ ○ ○ ○ ○ 4 to 20mA + event
VII	Pressure	0 ○ ○ ○ ○ ○ Low
		1 ○ ○ ○ ○ ○ Medium
VIII	Communication	0 ○ ○ ○ ○ ○ (None)
IX	Power	0 ○ ○ ○ ○ ○ 24Vdc
		1 ○ ○ ○ ○ ○ 100Vac 50/60Hz
		2 ○ ○ ○ ○ ○ 200Vac 50/60Hz
X	Option	00 ○ ○ ○ ○ ○ (None)
		D0 ○ ○ ○ ○ ○ Data attached

Butane and propane models

Example: CMG150P002000100

Table	Selection	Description
I	Basic model No.	Gas flow meter
II	Piping size	15 ○ ○ ○ ○ ○ 15A (1/2B)
		25 ○ ○ ○ ○ ○ 25A (1B)
		40 ○ ○ ○ ○ ○ 40A (1.5B)
		50 ○ ○ ○ ○ ○ 50A (2B)
III	Piping size	0 ○ ○ ○ ○ ○ Rc thread
		P ○ ○ ○ ○ ○ Propane
IV	Gas type	B ○ ○ ○ ○ ○ Butane
		004 ○ ○ ○ ○ ○ 4 m ³ /h(normal)
V	Flow range	010 ○ ○ ○ ○ ○ 10 m ³ /h(normal)
		002 ○ ○ ○ ○ ○ 2 m ³ /h(normal)
		025 ○ ○ ○ ○ ○ 25 m ³ /h(normal)
		050 ○ ○ ○ ○ ○ 50 m ³ /h(normal)
		001 ○ ○ ○ ○ ○ 1 m ³ /h(normal)
		003 ○ ○ ○ ○ ○ 3 m ³ /h(normal)
		008 ○ ○ ○ ○ ○ 8 m ³ /h(normal)
		020 ○ ○ ○ ○ ○ 20 m ³ /h(normal)
VI	Output	040 ○ ○ ○ ○ ○ 40 m ³ /h(normal)
		0 ○ ○ ○ ○ ○ 1 to 5Vdc
VII	Pressure	1 ○ ○ ○ ○ ○ 4 to 20mA + event
		0 ○ ○ ○ ○ ○ Low
VIII	Communication	0 ○ ○ ○ ○ ○ (None)
IX	Power	0 ○ ○ ○ ○ ○ 24Vdc
		1 ○ ○ ○ ○ ○ 100Vac 50/60Hz
		2 ○ ○ ○ ○ ○ 200Vac 50/60Hz
X	Option	00 ○ ○ ○ ○ ○ (None)
		D0 ○ ○ ○ ○ ○ Data attached



Yamatake Corporation
Control Product Division

Sales contact: Yamatake Corporation,
IBD Sensing and Control Department
Totate International Building

2-12-19 Shibuya Shibuya-ku Tokyo 150-8316 Japan

Phone: 81-3-3486-2380 Fax: 81-3-3486-2300

Specification are subject to change without notice.

Savemation
Saving through Automation

Printed in Japan.(PP)
Issued Nov.2000