

MVF Series

Micro Flow Vortex Gas Flowmeter

■ Features

- The MVF Series incorporates a μ F (Micro Flow) sensor made possible by silicon micro-machining and thin-film technologies. Because a high-sensitivity, high speed sensor that is a mere 1.7mm square and 0.5mm thick is used for the detection of vortex frequency, a wide measurement range of 100:1 has been achieved.
- Since temperature and pressure compensation functions are integrated, there is no need to use temperature and pressure sensors and compensation devices.
- Comprehensive interfaces such as 4–20mA instantaneous flow rate output, integrated pulse output, communications functions, etc. are integrated as standard functions. Therefore, this device can be used in combination with a wide variety of external devices.
- The display for instantaneous/integrated flow rate enables easy confirmation of the values at the work site.
- IP67 structure for outdoor applications.



■ Specifications

| Item | Description | | | |
|---|--|---|---|---|
| | MVF050 | MVF080 | MVF100 | MVF150 |
| Model No. | MVF050 | MVF080 | MVF100 | MVF150 |
| Port size | 50A(2B) | 80A(3B) | 100A(4B) | 150A(6B) |
| Flow rate measurement range (at a pressure of 0.5MPa) | 13 to 1280m ³ /h (normal) | 29 to 2826m ³ /h (normal) | 44 to 4352m ³ /h (normal) | 94 to 9364m ³ /h (normal) |
| | "Normal" refers to the volumetric flow rate (m ³ /h) after converting to 0°C, 101.325kPa | | | |
| Flow rate range settings | Customers can choose a range within the maximum ranges shown below. Since the measurement range differs according to the operating pressure, see the tables on pages 5 and 6 to specify the range. | | | |
| | 0 to 2302 | 0 to 5081 | 0 to 7825 | 0 to 16839 |
| Applicable gases | Air, nitrogen, argon, oxygen, carbon dioxide, natural gas, methane, propane, butane, and other inert gases and mixed gases outside the explosion limit range. | | | |
| Volumetric flow rate accuracy (for air) | ±2% RD at 13m ³ /h (normal) or more | ±2% RD at 20m ³ /h (normal) or more | ±2% RD at 28m ³ /h (normal) or more | ±2% RD at 51m ³ /h (normal) or more |
| | Differs according to operating pressure. For details, refer to the Tables for Specifying Volumetric Flow Rate Accuracy on page 5. | | | |
| Accuracy after temperature and pressure compensation | ±3.5% RD at pressure 0.5MPa and 71m ³ /h (normal) or more | ±3.5% RD at pressure 0.5MPa and 106m ³ /h (normal) or more | ±3.5% RD at pressure 0.5MPa and 150m ³ /h (normal) or more | ±3.5% RD at pressure 0.5MPa and 276m ³ /h (normal) or more |
| | For conditions other than the above, refer to the Tables for Specifying Overall Accuracy on page 6. Since a gauge pressure sensor is used, atmospheric pressure fluctuation error is not included. | | | |
| Minimum measurable flow rate (at pressure 0.1MPa) | 8m ³ /h (normal) | 11m ³ /h (normal) | 15m ³ /h (normal) | 32m ³ /h (normal) |
| Operating temperature | -15 to +60°C | | | |
| Applicable pressure | 0.0 to 1.0MPa | | | |
| Pressure resistance | 1.5MPa | | | |
| Operating humidity | 10 to 90% RH (no condensation allowed) | | | |
| Flow rate calculation / output updating cycle | 100ms | | | |
| Rated power supply | 24Vdc | | | |
| Power consumption | 100mA max. | | | |
| Output signal (1 point) | Instantaneous flow rate output: 4 to 20mAdc (allowable load resistance 600 Ω max.) Maximum current value: 23.2mA. At burnout, approx. 3.5mA output downscale. | | | |

| Item | | Description | | | |
|--|--|--|----------------|----------------------|------------|
| Integrated pulse output (1 point) | | Open collector output. Contact rating: 10 to 30Vdc, 20mA max. Pulse weight: Customer can specify 0.1, 1 or 10m ² /pulse. | | | |
| Communications function 1 | | RS-485 interface, 3-wire system | | | |
| Communications function 2 | | Mini-plug for PC Smart Loader connection, used for services by manufacturer. | | | |
| Display | Flow rate indication | Instantaneous flow rate indication: LCD 5+1 digits Integrated flow rate indication: LCD 8 digits | | | |
| | Instantaneous flow rate indication range (m³/h) | 0.0 to 5855.0 | 0.0 to 12912.0 | 0.0 to 19968.0 | 0 to 42787 |
| | Instantaneous flow rate indication resolution (m³/h) | 0.1 | 0.2 | 0.5 | 1 |
| | Integrated flow rate indication range (m³/h) | 0000000.0 to 9999999.9 | | 00000000 to 99999999 | |
| | Integrated indication resolution (m³) | 0.1 | | 1 | |
| | Integrated value backup | Automatic backup upon power failure | | | |
| Status indication | | Setting: displayed when the PC Smart Loader is connected. | | | |
| Material of gas-contacting parts | | Flow passage: SUS303, SUS304. μ F sensor: silicone, gold and others O-ring: type 4D (Viton) | | | |
| Converter case material | | Aluminum alloy | | | |
| Converter case coating | | Acrylic resin corrosion-resistant coating. Coating color: light beige | | | |
| Display glass material | | Tempered glass, thickness 10mm | | | |
| Mounting position | | (Flow direction) horizontal/vertical mounting | | | |
| Connection rating | | JIS 10K wafer | | | |
| Wiring connection port | | G1/2 female thread, 2 waterproof glands attached | | | |
| Protection | | IP67 (based on JIS 0920 and IEC 529). Waterproof structure on the assumption of outdoor installation | | | |
| Weight | | 7kg | 8kg | 10kg | 23kg |

● Structure

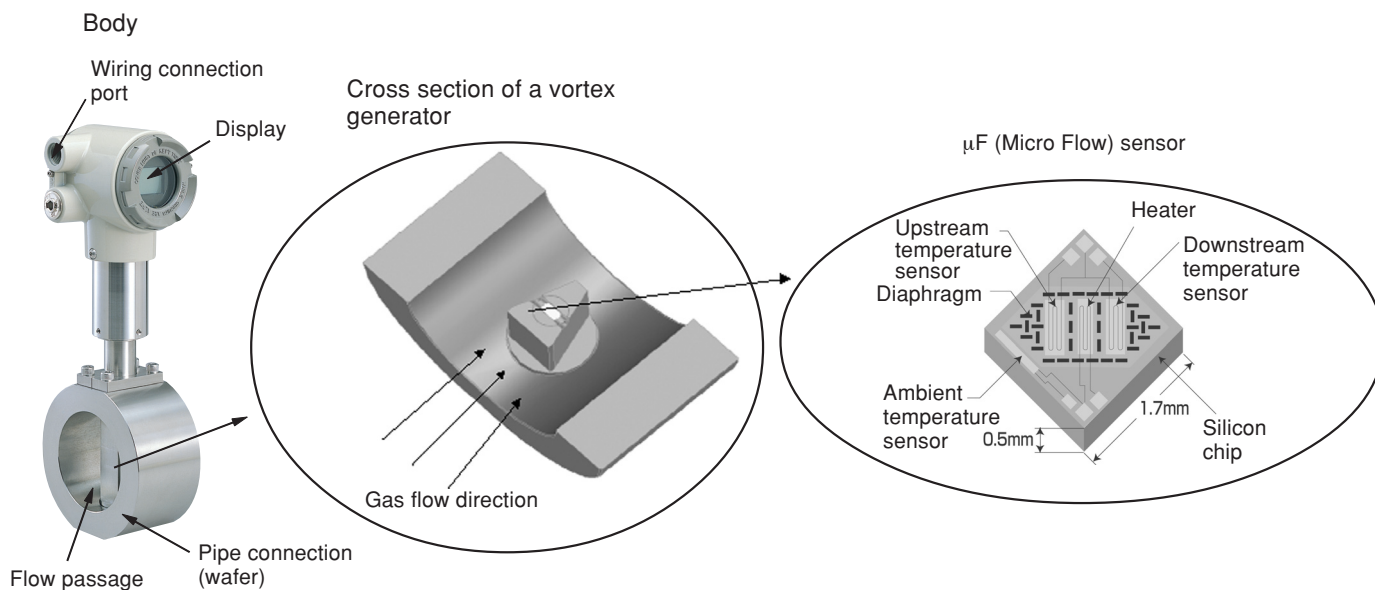

- A vortex generator, when installed in a pipe, generates a Karman vortex in proportion to the flow rate. When the frequency of the generated vortex is detected with a Micro Flow sensor, the flow speed can be measured. By multiplying the cross-section area, the volumetric flow rate can be calculated.
- The Micro Flow sensor has an integrated temperature sensor, and the converter has an integrated gauge pressure sensor. Therefore, mass flow rate can be calculated within the unit itself by temperature and pressure compensation computations based on Boyle's and Charles' laws.

● Filter installation

If oil mist or water enters this device, it may cause measurement error or faulty operation. For gases containing oil or water, such as compressed air, propane or butane, be sure to install a filter to ensure the long life of the device. If dust or welding fumes enter a vortex generator in large amounts, measurement accuracy may be impaired. When installing piping, be sure to fully purge the upstream and downstream piping .

● Model selection

- Select an MVF model by referring to the accuracy and measurement range tables.
- Actual flow rate calibration (for special models)

For standard model, actual flow rate calibration is not performed. The design of Yamatake's vortex shape is based on JIS Z 8766 (standard I-type). The performance of a vortex flowmeter is determined by the physical shape of the vortex generator, and its accuracy (uncertainty) is guaranteed to be within a certain range based on dimensional tolerances in manufacturing.

Model number: MFF100 Series
Specifications: For details, see Yamatake's specification sheet (No. CP-SS-1824E).



■ Flow rate calibration service (optional)

This product is designed and manufactured in accordance with JIS Z 8766 (standard I-type) and its accuracy (uncertainty) is guaranteed to be within a fixed range based on manufacturing tolerances. For standard models, therefore, flow-rate calibration is not performed.

The flow-rate calibration service described below is available separately. Please consult our sales representatives for further details.

1. Applicable models

All models of the MVF Series Micro Flow Vortex Gas Flowmeter

2. Calibration details

a) Calibration points:

5 (MVF 0, 25, 50, 75, and 100 % FS volumetric flow rate ranges)

Port size 50A:

0, 60, 120, 180, and 240 m³/h (actual)

Port size 80A:

0, 130, 260, 390, and 520 m³/h (actual)

Port size 100A:

0, 200, 400, 600, and 800 m³/h (actual)

Port size 150A:

0, 400, 800, 1200, and 1600 m³/h (actual)

* The inspection report includes the volumetric flow rate (m³/h) (actual) and equivalent mass flow rate (m³/h) (normal).

* (Actual) indicates the volumetric flow rate.

* (Normal) indicates an equivalent volumetric flow rate at 0 °C and 101.325 kPa·abs.

b) Calibration pressure: atmospheric pressure

c) Calibration gas: air

d) Documents submitted: Calibration report (air flow calibration results), traceability certificate, and traceability system diagram

e) Remarks

* Our standard (general-purpose) calibration specifications are described above. For calibration specifications other than those mentioned above, please contact us.

* JCSS calibration services (conforming to ISO/IEC 17025) are also available. Please contact us for further details.

Model Selection Guide

Be sure to specify the flow rate range and pulse weight in addition to the model number by the following method when ordering the device:

Example: Model No.: MVF0800SUN0112000, Range: 0 to 500m³/h (normal), Pulse weight: 1 m³/pulse

1. Flow rate range

Specify the range by referring to the tables on measurement range by pressure shown on pages 4 and 5.

- Applicable maximum range

| | |
|------|--|
| 50A | 80 to 8000m ³ /h (normal) |
| 80A | 160 to 16000m ³ /h (normal) |
| 100A | 240 to 24000m ³ /h (normal) |
| 150A | 480 to 48000m ³ /h (normal) |

2. Pulse weight

Select 0.1, 1 or 10m³/pulse.

Model number composition : I II III IV V VI VII VIII IX X XI XII XIII Example : MVF0800SUN0112000

| Item | Selection | Availability (O) | | | Description | | |
|------|-----------------------------------|------------------|-----------|--------------------------------------|---|--|------------------------|
| I | Basic model number | MVF | ↓ | ↓ | Micro Flow vortex gas flowmeter | | |
| II | Port size, range and pulse weight | | | | Port size | Factory setting when the range and pulse weight are not specified by the customer. | |
| | | | | | Range | Pulse weight | |
| | | 050 | ○ | ○ | 50A (2B) | 0 to 2000m ³ /h (normal) | 1m ³ /pulse |
| | | 080 | ○ | ○ | 80A (3B) | 0 to 5000m ³ /h (normal) | |
| | | 100 | ○ | ○ | 100A (4B) | 0 to 7000m ³ /h (normal) | |
| 150 | ○ | ○ | 150A (6B) | 0 to 16000m ³ /h (normal) | | | |
| III | Type | 0 | ○ | ○ | With temperature/pressure compensation function | | |
| | | L | ○ | ○ | Without pressure compensation, and with temperature compensation function | | |
| IV | Body material | S | ○ | ○ | SUS304 | | |
| V | Connection | U | ○ | ○ | JIS/ANSI wafer | | |
| VI | Gas type | N | ○ | – | Air, nitrogen, argon | | |
| | | S | – | ○ | Oxygen | | |
| | | C | ○ | – | Carbon dioxide | | |
| | | G | ○ | – | Natural gas (LNG base), methane | | |
| | | P | ○ | – | Propane | | |
| | | B | ○ | – | Butane | | |
| VII | Output | 0 | ○ | ○ | 4 to 20mAdc output + pulse output | | |
| VIII | Power supply | 1 | ○ | ○ | 24Vdc | | |
| IX | Communications | 1 | ○ | ○ | RS-485 (for use with EST, WEB100 and CMC10G) | | |
| X | Flow and mounting directions | 0 | ○ | ○ | Horizontal (flow: left → right): converter on top | | See note. |
| | | 1 | ○ | ○ | Horizontal (flow: L → R): converter on bottom | | |
| | | 2 | ○ | ○ | Horizontal (flow: R → L): converter on top | | |
| | | 3 | ○ | ○ | Horizontal (flow: R → L): converter on bottom | | |
| | | 4 | ○ | ○ | Vertical (flow: down → up): converter on left | | |
| | | 5 | ○ | ○ | Vertical (flow: up → down): converter on left | | |
| XI | Option 1 | 0 | ○ | – | None | | |
| | | 1 | ○ | ○ | Oil elimination process used on gas passage material | | |
| XII | Option 2 | 0 | ○ | ○ | None | | |
| XIII | Design code | 0 | ○ | ○ | Product version | | |

Note: Flow and mounting directions

• Flow direction: Left → Right

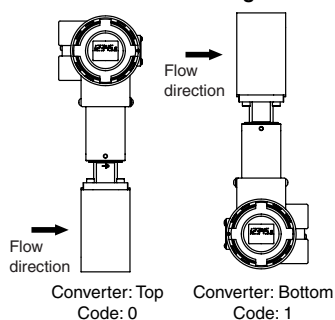

• Flow direction: Right → Left

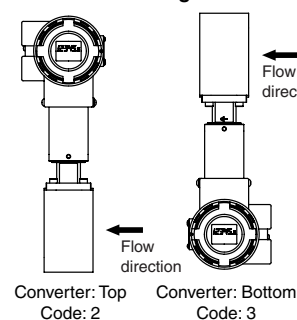

• Flow direction: Down → Up

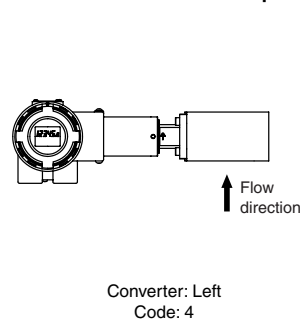

• Flow direction: Up → Down

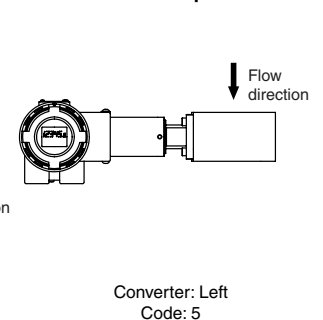

■ Specifying accuracy

See the tables for specifying accuracy on pages 20 and following. The accuracy tables show the ranges when the gas is air. To convert to other application conditions, calculate as shown below.

The Reynolds number (Re) used below is calculated using the formula

$$Re = (V \times D)/\nu.$$

V: velocity (m/s)

D: typical length (internal diameter of the MVF body(m))

MVF050: 52.5mm, MVF080: 78mm, MVF100: 96.8mm, MVF150: 142mm

ν : kinetic viscosity of the fluid (m²/s), = μ/ρ

For instance, in the case of air (dry air) at 0°C and 101.3kPa,

Viscosity $\mu = 17.24 \times 10^{-6}$ Pa·s

Density $\rho = 1.293$ kg/m³

From these conditions, the kinetic viscosity $\nu = 13.35 \times 10^{-6}$ m²/s.

Or, in the case of air (dry air) at 23°C and 700kPa,

$\nu = 1.883 \times 10^{-6}$ m²/s

As a calculation example, we will use the following conditions:

Installed flowmeter: MVF080

Fluid: air (dry air)

Operating pressure: 700kPa

Fluid temperature: 23°C

Atmospheric pressure: 101.3kPa

We will calculate the following items:

1. Minimum measurable flow rate
2. Maximum measurable flow rate
3. Accuracy after temperature and pressure compensation (examples: for 100 and 150m³/h (normal))

1. Minimum measurable flow rate (volumetric flow rate (m³/h) and mass flow rate (m³/h (normal)))

First, the minimum measurable flow speed is determined as the larger of 0.3m/s or the velocity at Re 3500. The velocity at Re 3500 is calculated from the formula for calculating Re:

$$V = Re \times \nu / D.$$

Here, if Re = 3500, $\nu = 1.883 \times 10^{-6}$ m²/s, and $D = 78 \times 10^{-3}$ m,

$$V = 3500 \times 1.883 \times 10^{-6} / (78 \times 10^{-3}) = 0.08\text{m/s}.$$

Since a velocity of 0.08m/s at Re 3500 is less than 0.3m/s, the minimum measurable velocity is 0.3m/s.

Now, the minimum measurable volumetric flow rate can be calculated as

$$Q_{\text{actual}} (\text{m}^3/\text{h}) = S \times V \times 3600 = 5.2.$$

S: flow path cross-section of MVF080 (m²) = $(78 \times 10^{-3})^2 \times \pi/4$

V: velocity (m/s) = 0.3

Therefore, volumetric flow rate can be measured down to 5.2m³/h.

Next, we can calculate the minimum mass flow rate Q_{normal} (m³/h (normal)) at 0°C and one atmospheric pressure, with temperature and pressure compensation.

$$Q_{\text{normal}} (\text{m}^3/\text{h}(\text{normal})) = 5.2 \times \frac{((273+0)/(273+23))}{\text{Amount of temperature compensation}} \times \frac{((101.3+700)/101.3)}{\text{Amount of pressure compensation}} = 38$$

Therefore, mass flow rate can be measured starting from a minimum of 38m³/h (normal).

2. Maximum measurable flow rate (volumetric flow rate (m³/h) and mass flow rate (m³/h (normal)))

MVF flowmeters can measure velocity up to 30m/s.

The volumetric flow rate Q_{actual} (m³/h) at velocity 30m/s is determined by $Q_{\text{actual}} (\text{m}^3/\text{h}) = S \times V \times 3600 = 516$.

S: flow path cross-section of MVF080 (m²) = $(78 \times 10^{-3})^2 \times \pi/4$

V: velocity (m/s) = 30

The volumetric flow rate can be measured up to 516m³/h.

Next, we can calculate the mass flow rate at 0°C and one atmospheric pressure, with temperature and pressure compensation, by

$$Q_{\text{normal}} (\text{m}^3/\text{h}(\text{normal})) = 516 \times \frac{((273+0)/(273+23))}{\text{Amount of temperature compensation}} \times \frac{((101.3+700)/101.3)}{\text{Amount of pressure compensation}} = 3765$$

Mass flow rate can be measured up to 3765m³/h (normal).

3. Accuracy after temperature and pressure compensation

As an example, we will calculate the accuracy after temperature and pressure compensation at 100m³/h and 150m³/h (normal), using the following formula:

$$\text{Accuracy after compensation (\%RD)} = \sqrt{\left(\frac{\text{volumetric flow rate accuracy (\%RD)}^2 + \text{temperature accuracy (\%RD)}^2 + \text{pressure accuracy (\%RD)}^2\right)}$$

Temperature and pressure sensor accuracy is as follows:

Temperature measurement accuracy: $\pm 2\%$ RD (absolute temperature base)

Pressure accuracy (% RD) = pressure measurement accuracy / (fluid pressure (MPa) + 0.1013(MPa))

In this case, the pressure measurement accuracy is 1%FS in the 0 to 1MPa range.

In order to calculate the volumetric flow rate accuracy, Re is first calculated from the mass flow rate (m³/h, normal).

The steps of the calculation are: mass flow rate ' volumetric flow rate ' velocity ' Re.

Mass flow rate \rightarrow volumetric flow rate calculation

$$Q_{\text{actual}} (\text{m}^3/\text{h}) = 100 \times ((273+23) / (273+0)) \times (101.3 / (101.3 + 700)) = 13.7$$

Volumetric flow rate \rightarrow Velocity calculation

$$\text{Velocity } V(\text{m/s}) = Q_{\text{actual}}(\text{m}^3/\text{h}) / S / 3600 = 13.7 / ((78 \times 10^{-3})^2 \times \pi / 4) / 3600 = 0.8$$

$$S: \text{flow path cross-section of MVF080 (m}^2\text{)} = (78 \times 10^{-3})^2 \times \pi / 4$$

Velocity \rightarrow Re calculation

$$Re = (V \times D) / \nu = 0.8 \times 78 \times 10^{-3} / 1.883 \times 10^{-6} = 33139$$

$$V: \text{velocity (m/s)} = 0.8$$

$$D: \text{internal diameter of the MVF body (m); for MVF080, } D = 78\text{mm}$$

$$\nu: \text{kinetic viscosity of fluid (m}^2\text{/s)}$$

$$\text{For dry air, } 23^\circ\text{C and } 700\text{kPa, } \nu = 1.883 \times 10^{-6}\text{m}^2\text{/s}$$

Volumetric flow rate accuracy is checked by the Re value.

With Re = 33139 (flow rate = 0.8m/s), since the velocity is 0.5m/s or more and Re is in the 10000-35000 range, the volumetric flow rate accuracy is $\pm 4\%$ RD.

☞ ● Specifying volumetric flow rate accuracy (below)

Volumetric flow rate accuracy = 4% RD

Temperature accuracy = 2% RD

Pressure accuracy = 0.01 / fluid pressure (MPa) = 0.01/0.7 = 1.4% DR

Based on these conditions,

$$\text{The accuracy after temperature compensation} = \sqrt{(4\%)^2 + (2\%)^2 + (1.4\%)^2} = 4.7\%RD$$

At 100m³/h (normal), the accuracy is 4.7% RD.

The calculation is similar for 150m³/h (normal).

Re = 49517 (velocity = 1.2m/s).

Since Re is more than 35000, the volumetric flow rate accuracy is $\pm 2\%$ RD.

☞ ● Specifying volumetric flow rate accuracy (below)

Volumetric flow rate accuracy = 2% RD

Temperature accuracy = 2% RD

Pressure accuracy = 0.01 / fluid pressure (MPa) = 0.01/0.7 = 1.4% DR

Based on these conditions,

$$\text{The accuracy after temperature compensation} = \sqrt{(2\%)^2 + (2\%)^2 + (1.4\%)^2} = 3.2\%RD$$

At 150m³/h (normal), the accuracy is 3.2% RD.

● Specifying volumetric flow rate accuracy

The volumetric flow rate accuracy is specified as follows:

- MVF50 (pipe size 50A)
 - 4% RD when velocity is 0.5m/s or more, and Re is 15000 to less than 35000.
 - 2% RD when Re is 35000 or more.
- MVF80 (pipe size 80A)
 - 4% RD when velocity is 0.5m/s or more, and Re is 10000 to less than 35000.
 - 2% RD when Re is 35000 or more.
- MVF100 (pipe size 100A)
 - 4% RD when velocity is 0.5m/s or more, and Re is 10000 to less than 40000.
 - 2% RD when Re is 40000 or more.
- MVF150 (pipe size 150A)
 - 4% RD when velocity is 0.5m/s or more, and Re is 10000 to less than 50000.
 - 2% RD when Re is 50000 or more.

■ Table for Specifying Volumetric Flow Rate Accuracy

Flow rate unit: m³/h (actual at 23°C)

Accuracy differs depending on operating pressure and flow rate range.

● MVF050 (port size 50A)

| Operating pressure (KPa) | Minimum measurable flow rate Q min. | Accuracy | | |
|--------------------------|-------------------------------------|--------------|-------------|--------------|
| | | ±Q min. | ±4% RD | ±2% RD |
| 10 | 7.3 | 7.3 ≤ Q ≤ 31 | 31 < Q < 73 | 73 ≤ Q ≤ 234 |
| 20 | 6.7 | 6.7 ≤ Q ≤ 29 | 29 < Q < 67 | 67 ≤ Q ≤ 234 |
| 30 | 6.2 | 6.2 ≤ Q ≤ 27 | 27 < Q < 62 | 62 ≤ Q ≤ 234 |
| 40 | 5.8 | 5.8 ≤ Q ≤ 25 | 25 < Q < 58 | 58 ≤ Q ≤ 234 |
| 50 | 5.4 | 5.4 ≤ Q ≤ 23 | 23 < Q < 54 | 54 ≤ Q ≤ 234 |
| 60 | 5.0 | 5.0 ≤ Q ≤ 22 | 22 < Q < 50 | 50 ≤ Q ≤ 234 |
| 70 | 4.7 | 4.7 ≤ Q ≤ 20 | 20 < Q < 47 | 47 ≤ Q ≤ 234 |
| 80 | 4.5 | 4.5 ≤ Q ≤ 19 | 19 < Q < 45 | 45 ≤ Q ≤ 234 |
| 90 | 4.3 | 4.3 ≤ Q ≤ 18 | 18 < Q < 43 | 43 ≤ Q ≤ 234 |
| 100 | 4.0 | 4.0 ≤ Q ≤ 17 | 17 < Q < 40 | 40 ≤ Q ≤ 234 |
| 200 | 2.7 | 2.7 ≤ Q ≤ 12 | 12 < Q < 27 | 27 ≤ Q ≤ 234 |
| 300 | 2.3 | 2.3 ≤ Q ≤ 9 | 9 < Q < 20 | 20 ≤ Q ≤ 234 |
| 400 | 2.3 | 2.3 ≤ Q ≤ 7 | 7 < Q < 16 | 16 ≤ Q ≤ 234 |
| 500 | 2.3 | 2.3 ≤ Q ≤ 6 | 6 < Q < 14 | 14 ≤ Q ≤ 234 |
| 600 | 2.3 | 2.3 ≤ Q ≤ 5 | 5 < Q < 12 | 12 ≤ Q ≤ 234 |
| 700 | 2.3 | 2.3 ≤ Q ≤ 4 | 4 < Q < 10 | 10 ≤ Q ≤ 234 |
| 800 | 2.3 | 2.3 ≤ Q ≤ 4 | 4 < Q < 9 | 9 ≤ Q ≤ 234 |
| 900 | 2.3 | 2.3 ≤ Q ≤ 4 | 4 < Q < 8 | 8 ≤ Q ≤ 234 |
| 980 | 2.3 | 2.3 ≤ Q ≤ 4 | 4 < Q < 8 | 8 ≤ Q ≤ 234 |

● MVF080 (port size 80A)

| Operating pressure (KPa) | Minimum measurable flow rate Q min. | Accuracy | | |
|--------------------------|-------------------------------------|---------------|--------------|---------------|
| | | ±Q min. | ±4% RD | ±2% RD |
| 10 | 10.9 | 10.9 ≤ Q ≤ 31 | 31 < Q < 109 | 109 ≤ Q ≤ 516 |
| 20 | 10.0 | 10.0 ≤ Q ≤ 28 | 28 < Q < 100 | 100 ≤ Q ≤ 516 |
| 30 | 9.2 | 9.2 ≤ Q ≤ 26 | 26 < Q < 92 | 92 ≤ Q ≤ 516 |
| 40 | 8.6 | 8.6 ≤ Q ≤ 24 | 24 < Q < 86 | 86 ≤ Q ≤ 516 |
| 50 | 8.0 | 8.0 ≤ Q ≤ 23 | 23 < Q < 80 | 80 ≤ Q ≤ 516 |
| 60 | 7.5 | 7.5 ≤ Q ≤ 21 | 21 < Q < 75 | 75 ≤ Q ≤ 516 |
| 70 | 7.1 | 7.1 ≤ Q ≤ 20 | 20 < Q < 71 | 71 ≤ Q ≤ 516 |
| 80 | 6.7 | 6.7 ≤ Q ≤ 19 | 19 < Q < 67 | 67 ≤ Q ≤ 516 |
| 90 | 6.3 | 6.3 ≤ Q ≤ 18 | 18 < Q < 63 | 63 ≤ Q ≤ 516 |
| 100 | 6.0 | 6.0 ≤ Q ≤ 17 | 17 < Q < 60 | 60 ≤ Q ≤ 516 |
| 200 | 5.2 | 5.2 ≤ Q ≤ 11 | 11 < Q < 40 | 40 ≤ Q ≤ 516 |
| 300 | 5.2 | 5.2 ≤ Q ≤ 9 | 9 < Q < 30 | 30 ≤ Q ≤ 516 |
| 400 | 5.2 | 5.2 ≤ Q ≤ 9 | 9 < Q < 24 | 24 ≤ Q ≤ 516 |
| 500 | 5.2 | 5.2 ≤ Q ≤ 9 | 9 < Q < 20 | 20 ≤ Q ≤ 516 |
| 600 | 5.2 | 5.2 ≤ Q ≤ 9 | 9 < Q < 17 | 17 ≤ Q ≤ 516 |
| 700 | 5.2 | 5.2 ≤ Q ≤ 9 | 9 < Q < 15 | 15 ≤ Q ≤ 516 |
| 800 | 5.2 | 5.2 ≤ Q ≤ 9 | 9 < Q < 13 | 13 ≤ Q ≤ 516 |
| 900 | 5.2 | 5.2 ≤ Q ≤ 9 | 9 < Q < 12 | 12 ≤ Q ≤ 516 |
| 980 | 5.2 | 5.2 ≤ Q ≤ 9 | 9 < Q < 11 | 11 ≤ Q ≤ 516 |

● MVF100 (port size 100A)

| Operating pressure (KPa) | Minimum measurable flow rate Q min. | Accuracy | | |
|--------------------------|-------------------------------------|---------------|--------------|---------------|
| | | ±Q min. | ±4% RD | ±2% RD |
| 10 | 13.5 | 13.5 ≤ Q ≤ 39 | 39 < Q < 154 | 154 ≤ Q ≤ 795 |
| 20 | 12.4 | 12.4 ≤ Q ≤ 35 | 35 < Q < 141 | 141 ≤ Q ≤ 795 |
| 30 | 11.4 | 11.4 ≤ Q ≤ 33 | 33 < Q < 131 | 131 ≤ Q ≤ 795 |
| 40 | 10.6 | 10.6 ≤ Q ≤ 30 | 30 < Q < 121 | 121 ≤ Q ≤ 795 |
| 50 | 9.9 | 9.9 ≤ Q ≤ 28 | 28 < Q < 113 | 113 ≤ Q ≤ 795 |
| 60 | 9.3 | 9.3 ≤ Q ≤ 27 | 27 < Q < 106 | 106 ≤ Q ≤ 795 |
| 70 | 8.8 | 8.8 ≤ Q ≤ 25 | 25 < Q < 100 | 100 ≤ Q ≤ 795 |
| 80 | 8.3 | 8.3 ≤ Q ≤ 24 | 24 < Q < 95 | 95 ≤ Q ≤ 795 |
| 90 | 7.9 | 7.9 ≤ Q ≤ 22 | 22 < Q < 90 | 90 ≤ Q ≤ 795 |
| 100 | 7.9 | 7.9 ≤ Q ≤ 21 | 21 < Q < 85 | 85 ≤ Q ≤ 795 |
| 200 | 7.9 | 7.9 ≤ Q ≤ 14 | 14 < Q < 57 | 57 ≤ Q ≤ 795 |
| 300 | 7.9 | 7.9 ≤ Q ≤ 13 | 13 < Q < 43 | 43 ≤ Q ≤ 795 |
| 400 | 7.9 | 7.9 ≤ Q ≤ 13 | 13 < Q < 34 | 34 ≤ Q ≤ 795 |
| 500 | 7.9 | 7.9 ≤ Q ≤ 13 | 13 < Q < 29 | 29 ≤ Q ≤ 795 |
| 600 | 7.9 | 7.9 ≤ Q ≤ 13 | 13 < Q < 24 | 24 ≤ Q ≤ 795 |
| 700 | 7.9 | 7.9 ≤ Q ≤ 13 | 13 < Q < 21 | 21 ≤ Q ≤ 795 |
| 800 | 7.9 | 7.9 ≤ Q ≤ 13 | 13 < Q < 19 | 19 ≤ Q ≤ 795 |
| 900 | 7.9 | 7.9 ≤ Q ≤ 13 | 13 < Q < 17 | 17 ≤ Q ≤ 795 |
| 980 | 7.9 | 7.9 ≤ Q ≤ 13 | 13 < Q < 16 | 16 ≤ Q ≤ 795 |

● MVF150 (port size 150A)

| Operating pressure (KPa) | Minimum measurable flow rate Q min. | Accuracy | | |
|--------------------------|-------------------------------------|---------------|--------------|----------------|
| | | ±Q min. | ±4% RD | ±2% RD |
| 10 | 19.8 | 19.8 ≤ Q ≤ 56 | 56 < Q < 282 | 282 ≤ Q ≤ 1710 |
| 20 | 18.1 | 18.1 ≤ Q ≤ 52 | 52 < Q < 259 | 259 ≤ Q ≤ 1710 |
| 30 | 17.1 | 17.1 ≤ Q ≤ 48 | 48 < Q < 239 | 239 ≤ Q ≤ 1710 |
| 40 | 17.1 | 17.1 ≤ Q ≤ 44 | 44 < Q < 222 | 222 ≤ Q ≤ 1710 |
| 50 | 17.1 | 17.1 ≤ Q ≤ 42 | 42 < Q < 208 | 208 ≤ Q ≤ 1710 |
| 60 | 17.1 | 17.1 ≤ Q ≤ 39 | 39 < Q < 195 | 195 ≤ Q ≤ 1710 |
| 70 | 17.1 | 17.1 ≤ Q ≤ 37 | 37 < Q < 184 | 184 ≤ Q ≤ 1710 |
| 80 | 17.1 | 17.1 ≤ Q ≤ 35 | 35 < Q < 173 | 173 ≤ Q ≤ 1710 |
| 90 | 17.1 | 17.1 ≤ Q ≤ 33 | 33 < Q < 164 | 164 ≤ Q ≤ 1710 |
| 100 | 17.1 | 17.1 ≤ Q ≤ 31 | 31 < Q < 156 | 156 ≤ Q ≤ 1710 |
| 200 | 17.1 | 17.1 ≤ Q ≤ 29 | 29 < Q < 104 | 104 ≤ Q ≤ 1710 |
| 300 | 17.1 | 17.1 ≤ Q ≤ 29 | 29 < Q < 78 | 78 ≤ Q ≤ 1710 |
| 400 | 17.1 | 17.1 ≤ Q ≤ 29 | 29 < Q < 63 | 63 ≤ Q ≤ 1710 |
| 500 | 17.1 | 17.1 ≤ Q ≤ 29 | 29 < Q < 52 | 52 ≤ Q ≤ 1710 |
| 600 | 17.1 | 17.1 ≤ Q ≤ 29 | 29 < Q < 45 | 45 ≤ Q ≤ 1710 |
| 700 | 17.1 | 17.1 ≤ Q ≤ 29 | 29 < Q < 39 | 39 ≤ Q ≤ 1710 |
| 800 | 17.1 | 17.1 ≤ Q ≤ 29 | 29 < Q < 35 | 35 ≤ Q ≤ 1710 |
| 900 | 17.1 | 17.1 ≤ Q ≤ 29 | 29 < Q < 31 | 31 ≤ Q ≤ 1710 |
| 980 | 17.1 | 17.1 ≤ Q ≤ 29 | 29 < Q < 29 | 29 ≤ Q ≤ 1710 |

■ Table for Specifying Overall Accuracy (after temperature and pressure compensation)

Flow rate unit: m³/h (normal)

Accuracy differs according to operating pressure and flow rate range.

● MVF050 (port size 50A)

| Operating pressure (MPa) | Minimum measurable flow rate Q min. | Accuracy | | |
|--------------------------|-------------------------------------|---------------|-------------|---------------|
| | | ±Qmin | ±6.7%RD | ±5.7%RD |
| 0.10 | 7.4 | ±Qmin | ±6.7%RD | ±5.7%RD |
| | | 7.4 ≤ Q ≤ 32 | 32 < Q < 74 | 74 ≤ Q ≤ 428 |
| 0.15 | 7.4 | ±Qmin | ±6.0%RD | ±4.9%RD |
| | | 7.4 ≤ Q ≤ 32 | 32 < Q < 74 | 74 ≤ Q ≤ 535 |
| 0.20 | 7.4 | ±Qmin | ±5.6%RD | ±4.4%RD |
| | | 7.4 ≤ Q ≤ 32 | 32 < Q < 74 | 74 ≤ Q ≤ 641 |
| 0.30 | 8.5 | ±Qmin | ±5.1%RD | ±3.8%RD |
| | | 8.5 ≤ Q ≤ 32 | 32 < Q < 74 | 74 ≤ Q ≤ 854 |
| 0.40 | 10.7 | ±Qmin | ±4.9%RD | ±3.5%RD |
| | | 10.7 ≤ Q ≤ 32 | 32 < Q < 74 | 74 ≤ Q ≤ 1067 |
| 0.50 | 12.8 | ±Qmin | ±4.8%RD | ±3.3%RD |
| | | 12.8 ≤ Q ≤ 32 | 32 < Q < 74 | 74 ≤ Q ≤ 1280 |
| 0.60 | 14.9 | ±Qmin | ±4.7%RD | ±3.2%RD |
| | | 14.9 ≤ Q ≤ 32 | 32 < Q < 74 | 74 ≤ Q ≤ 1493 |
| 0.70 | 17.1 | ±Qmin | ±4.6%RD | ±3.1%RD |
| | | 17.1 ≤ Q ≤ 32 | 32 < Q < 74 | 74 ≤ Q ≤ 1706 |
| 0.80 | 19.2 | ±Qmin | ±4.6%RD | ±3.0%RD |
| | | 19.2 ≤ Q ≤ 32 | 32 < Q < 74 | 74 ≤ Q ≤ 1919 |
| 0.90 | 21.3 | ±Qmin | ±4.6%RD | ±3.0%RD |
| | | 21.3 ≤ Q ≤ 36 | 36 < Q < 74 | 74 ≤ Q ≤ 2131 |
| 0.98 | 23.0 | ±Qmin | ±4.6%RD | ±3.0%RD |
| | | 23.0 ≤ Q ≤ 38 | 38 < Q < 74 | 74 ≤ Q ≤ 2302 |

● MVF080 (port size 80A)

| Operating pressure (MPa) | Minimum measurable flow rate Q min. | Accuracy | | |
|--------------------------|-------------------------------------|---------------|--------------|----------------|
| | | ±Qmin | ±6.7%RD | ±5.7%RD |
| 0.10 | 11.0 | ±Qmin | ±6.7%RD | ±5.7%RD |
| | | 11.0 ≤ Q ≤ 31 | 31 < Q < 110 | 110 ≤ Q ≤ 946 |
| 0.15 | 11.8 | ±Qmin | ±6.0%RD | ±4.9%RD |
| | | 11.8 ≤ Q ≤ 31 | 31 < Q < 110 | 110 ≤ Q ≤ 1181 |
| 0.20 | 14.2 | ±Qmin | ±5.6%RD | ±4.4%RD |
| | | 14.2 ≤ Q ≤ 31 | 31 < Q < 110 | 110 ≤ Q ≤ 1416 |
| 0.30 | 18.9 | ±Qmin | ±5.1%RD | ±3.8%RD |
| | | 18.9 ≤ Q ≤ 31 | 31 < Q < 110 | 110 ≤ Q ≤ 1886 |
| 0.40 | 23.6 | ±Qmin | ±4.9%RD | ±3.5%RD |
| | | 23.6 ≤ Q ≤ 39 | 39 < Q < 110 | 110 ≤ Q ≤ 2355 |
| 0.50 | 28.3 | ±Qmin | ±4.8%RD | ±3.3%RD |
| | | 28.3 ≤ Q ≤ 47 | 47 < Q < 110 | 110 ≤ Q ≤ 2825 |
| 0.60 | 33.0 | ±Qmin | ±4.7%RD | ±3.2%RD |
| | | 33.0 ≤ Q ≤ 55 | 55 < Q < 110 | 110 ≤ Q ≤ 3295 |
| 0.70 | 37.6 | ±Qmin | ±4.6%RD | ±3.1%RD |
| | | 37.6 ≤ Q ≤ 63 | 63 < Q < 110 | 110 ≤ Q ≤ 3765 |
| 0.80 | 42.3 | ±Qmin | ±4.6%RD | ±3.0%RD |
| | | 42.3 ≤ Q ≤ 71 | 71 < Q < 110 | 110 ≤ Q ≤ 4235 |
| 0.90 | 47.0 | ±Qmin | ±4.6%RD | ±3.0%RD |
| | | 47.0 ≤ Q ≤ 78 | 78 < Q < 110 | 110 ≤ Q ≤ 4705 |
| 0.98 | 50.8 | ±Qmin | ±4.6%RD | ±3.0%RD |
| | | 50.8 ≤ Q ≤ 85 | 85 < Q < 110 | 110 ≤ Q ≤ 5081 |

● MVF100 (port size 100A)

| Operating pressure (MPa) | Minimum measurable flow rate Q min. | Accuracy | | |
|--------------------------|-------------------------------------|----------------|---------------|----------------|
| | | ±Qmin | ±6.7%RD | ±5.7%RD |
| 0.10 | 14.6 | ±Qmin | ±6.7%RD | ±5.7%RD |
| | | 14.6 ≤ Q ≤ 39 | 39 < Q < 156 | 156 ≤ Q ≤ 1457 |
| 0.15 | 18.2 | ±Qmin | ±6.0%RD | ±4.9%RD |
| | | 18.2 ≤ Q ≤ 39 | 39 < Q < 156 | 156 ≤ Q ≤ 1819 |
| 0.20 | 21.8 | ±Qmin | ±5.6%RD | ±4.4%RD |
| | | 21.8 ≤ Q ≤ 39 | 39 < Q < 156 | 156 ≤ Q ≤ 2180 |
| 0.30 | 29.0 | ±Qmin | ±5.1%RD | ±3.8%RD |
| | | 29.0 ≤ Q ≤ 48 | 48 < Q < 156 | 156 ≤ Q ≤ 2904 |
| 0.40 | 36.3 | ±Qmin | ±4.9%RD | ±3.5%RD |
| | | 36.3 ≤ Q ≤ 60 | 60 < Q < 156 | 156 ≤ Q ≤ 3628 |
| 0.50 | 43.5 | ±Qmin | ±4.8%RD | ±3.3%RD |
| | | 43.5 ≤ Q ≤ 73 | 73 < Q < 156 | 156 ≤ Q ≤ 4351 |
| 0.60 | 50.7 | ±Qmin | ±4.7%RD | ±3.2%RD |
| | | 50.7 ≤ Q ≤ 85 | 85 < Q < 156 | 156 ≤ Q ≤ 5075 |
| 0.70 | 58.0 | ±Qmin | ±4.6%RD | ±3.1%RD |
| | | 58.0 ≤ Q ≤ 97 | 97 < Q < 156 | 156 ≤ Q ≤ 5799 |
| 0.80 | 65.2 | ±Qmin | ±4.6%RD | ±3.0%RD |
| | | 65.2 ≤ Q ≤ 109 | 109 < Q < 156 | 156 ≤ Q ≤ 6522 |
| 0.90 | 72.5 | ±Qmin | ±4.6%RD | ±3.0%RD |
| | | 72.5 ≤ Q ≤ 121 | 121 < Q < 156 | 156 ≤ Q ≤ 7246 |
| 0.98 | 78.2 | ±Qmin | ±4.6%RD | ±3.0%RD |
| | | 78.2 ≤ Q ≤ 130 | 130 < Q < 156 | 156 ≤ Q ≤ 7825 |

● MVF150 (port size 150A)

| Operating pressure (MPa) | Minimum measurable flow rate Q min. | Accuracy | | |
|--------------------------|-------------------------------------|-----------------|---------------|-----------------|
| | | ±Qmin | ±6.7%RD | ±5.7%RD |
| 0.10 | 31.3 | ±Qmin | ±6.7%RD | ±5.7%RD |
| | | 31.3 ≤ Q ≤ 57 | 57 < Q < 286 | 286 ≤ Q ≤ 3135 |
| 0.15 | 39.1 | ±Qmin | ±6.0%RD | ±4.9%RD |
| | | 39.1 ≤ Q ≤ 65 | 65 < Q < 286 | 286 ≤ Q ≤ 3913 |
| 0.20 | 46.9 | ±Qmin | ±5.6%RD | ±4.4%RD |
| | | 46.9 ≤ Q ≤ 78 | 78 < Q < 286 | 286 ≤ Q ≤ 4692 |
| 0.30 | 62.5 | ±Qmin | ±5.1%RD | ±3.8%RD |
| | | 62.5 ≤ Q ≤ 104 | 104 < Q < 286 | 286 ≤ Q ≤ 6249 |
| 0.40 | 78.1 | ±Qmin | ±4.9%RD | ±3.5%RD |
| | | 78.1 ≤ Q ≤ 130 | 130 < Q < 286 | 286 ≤ Q ≤ 7806 |
| 0.50 | 93.6 | ±Qmin | ±4.8%RD | ±3.3%RD |
| | | 93.6 ≤ Q ≤ 156 | 156 < Q < 286 | 286 ≤ Q ≤ 9364 |
| 0.60 | 109.2 | ±Qmin | ±4.7%RD | ±3.2%RD |
| | | 109.2 ≤ Q ≤ 182 | 182 < Q < 286 | 286 ≤ Q ≤ 10921 |
| 0.70 | 124.8 | ±Qmin | ±4.6%RD | ±3.1%RD |
| | | 124.8 ≤ Q ≤ 208 | 208 < Q < 286 | 286 ≤ Q ≤ 12478 |
| 0.80 | 140.4 | ±Qmin | ±4.6%RD | ±3.0%RD |
| | | 140.4 ≤ Q ≤ 234 | 234 < Q < 286 | 286 ≤ Q ≤ 14035 |
| 0.90 | 155.9 | ±Qmin | ±4.6%RD | ±3.0%RD |
| | | 155.9 ≤ Q ≤ 260 | 260 < Q < 286 | 286 ≤ Q ≤ 15593 |
| 0.98 | 168.4 | ±Qmin | ±4.6%RD | ±3.0%RD |
| | | 168.4 ≤ Q ≤ 281 | 281 < Q < 286 | 286 ≤ Q ≤ 16838 |

■ Dimensions

(unit: mm)

● MVF050

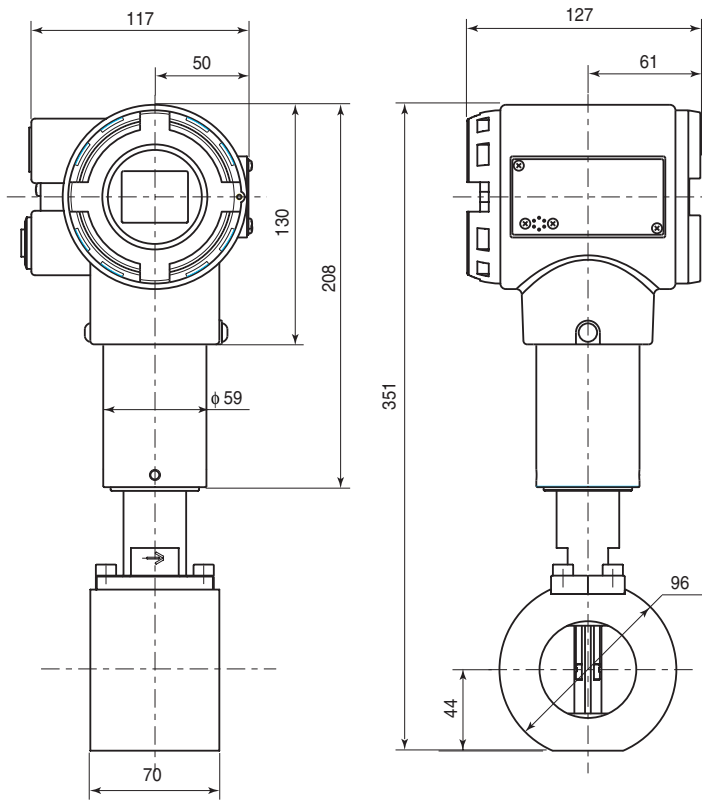

● MVF080

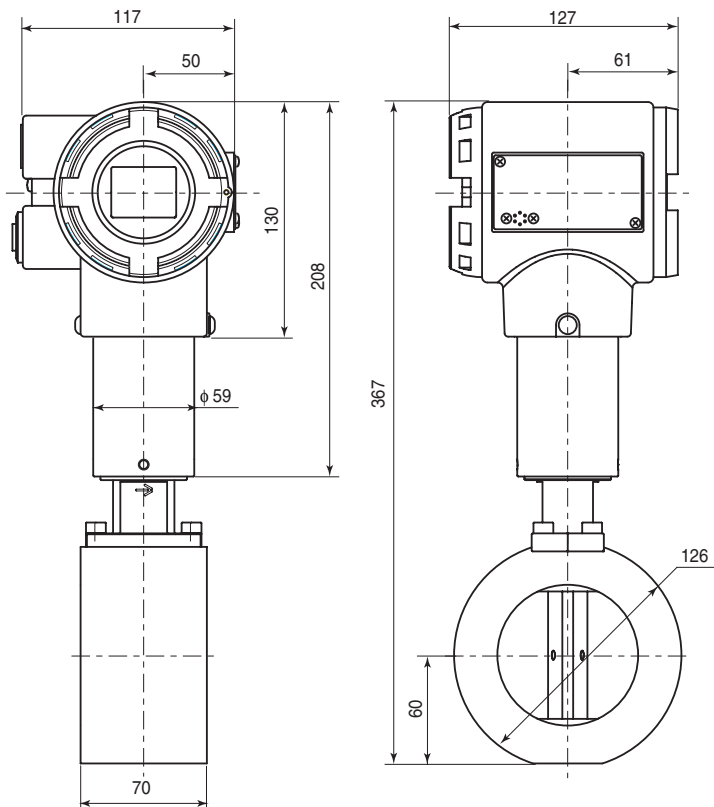

● MVF100

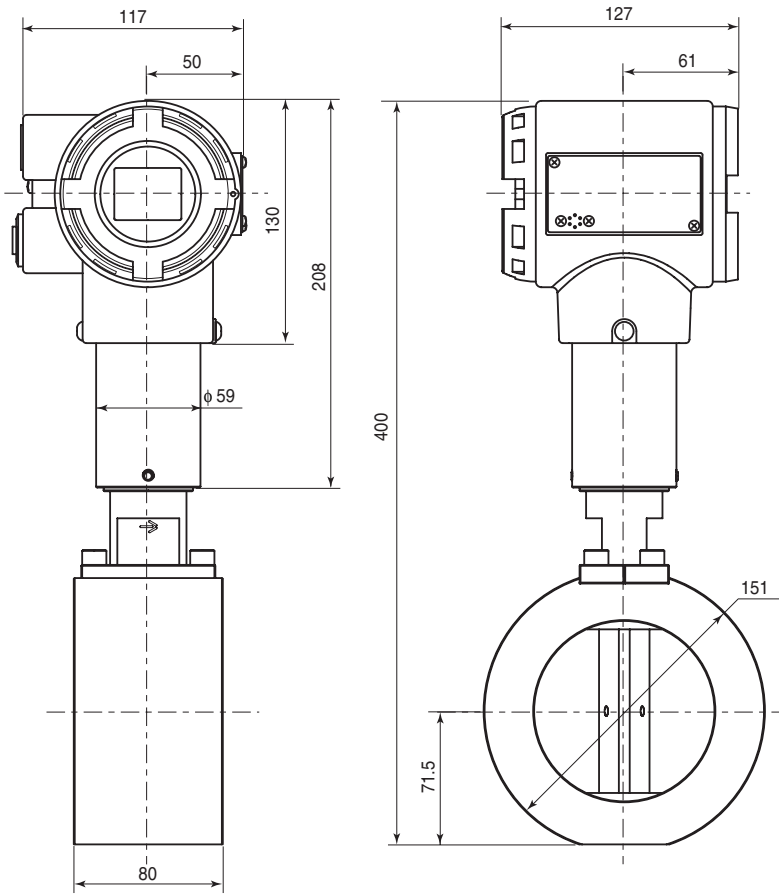

● MVF150

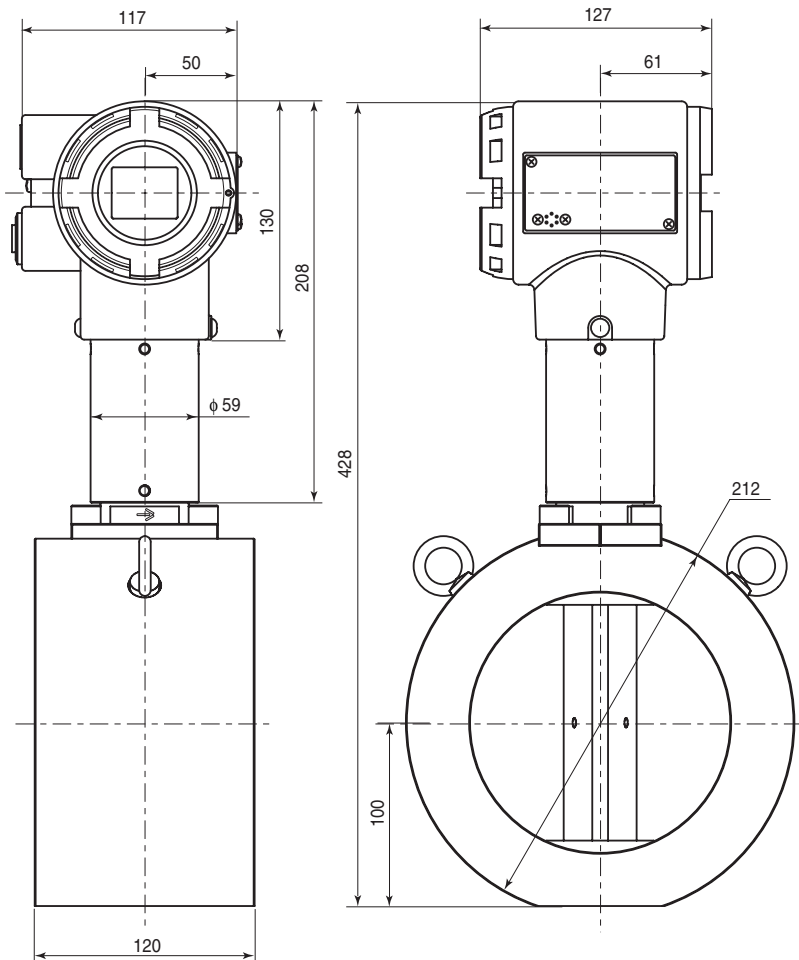

■ Wiring Diagram

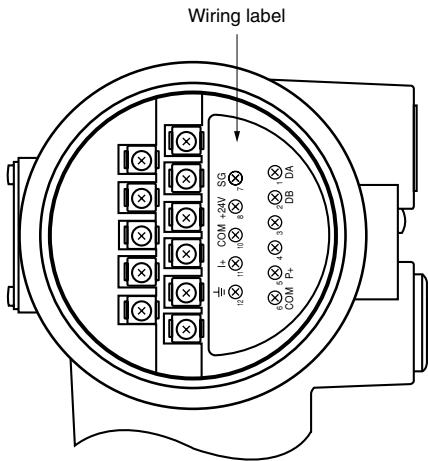

| Terminal No. | Signal name | Description |
|--------------|-------------|-----------------------------------|
| 1 | DA | RS-485 communications DA |
| 2 | DB | RS-485 communications DB |
| 3 | Unused | Do not connect. |
| 4 | Unused | Do not connect. |
| 5 | P+ | Pulse output (NPN open collector) |
| 6 | COM | Common |
| 7 | SG | RS-485 communications common |
| 8 | +24V | Power supply: 24Vdc |
| 9 | COM | Common |
| 10 | I+ | 4 to 20mA output |
| 11 | ⏏ | Earth terminal |

! Handling Precautions

- Connect each terminal securely using crimp-type terminal lugs to ensure good contact.
- Use the correct crimp-type terminal lugs for M4 screws.
- Be sure that the tightening torque for the terminal screws is less than $0.8\text{N} \cdot \text{m}$.
- Use JIS C 3401 cables less than 2.2mm in diameter for control wiring (CVV, etc.), except for RS-485 communications.
- Use twisted-pair shielded cables for the wiring of RS-485 communications. Be sure to use a terminating resistor (150Ω , $1/2\text{W}$).
- The wiring connection port is G1/2 female thread. Use the included waterproof gland (2 units included) except for direct connection of an electric wiring conduit.

● External wiring example

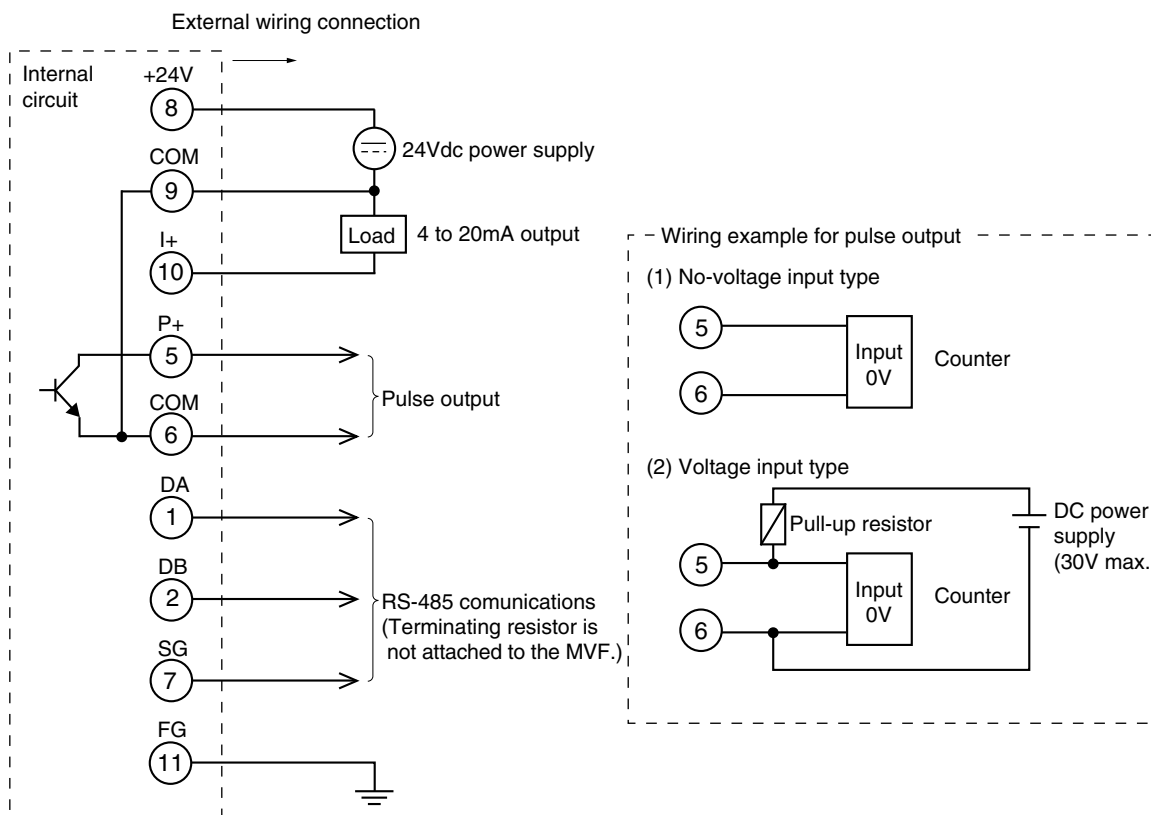

■ Pressure Loss

50A: 3kPa max. at 920m³/h (normal) (air: flow rate 30m/s, primary pressure 100kPa)

80A: 3kPa max. at 1020m³/h (normal) (air: flow rate 30m/s, primary pressure 100kPa)

100A: 3kPa max. at 1580m³/h (normal) (air: flow rate 30m/s, primary pressure 100kPa)

150A: 3kPa max. at 3400m³/h (normal) (air: flow rate 30m/s, primary pressure 100kPa)

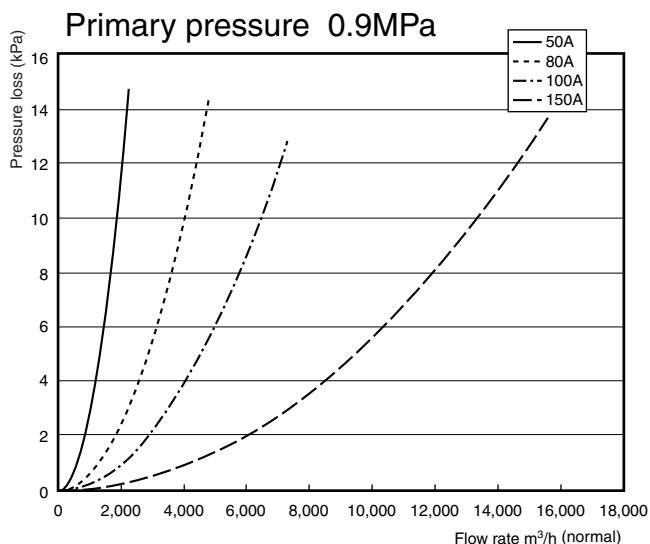
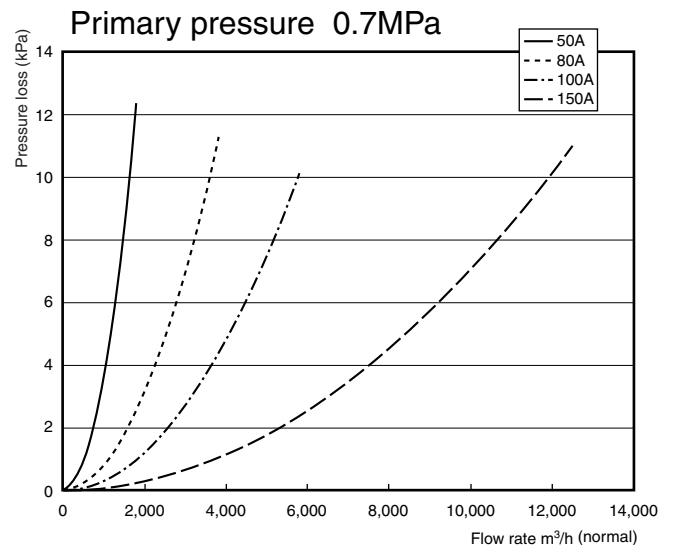
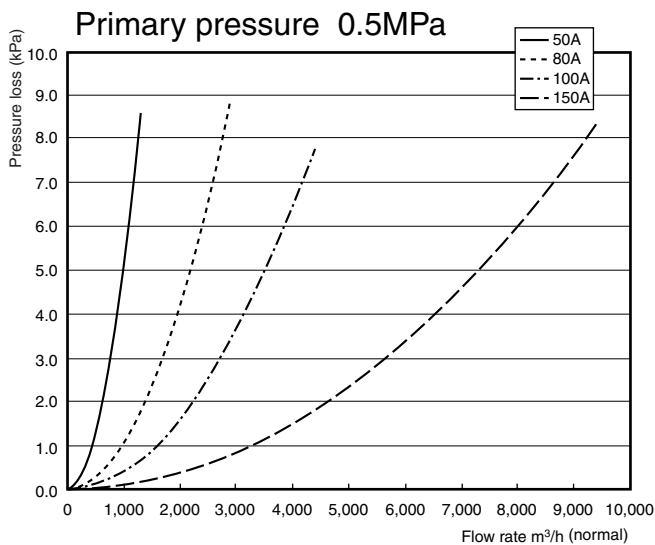
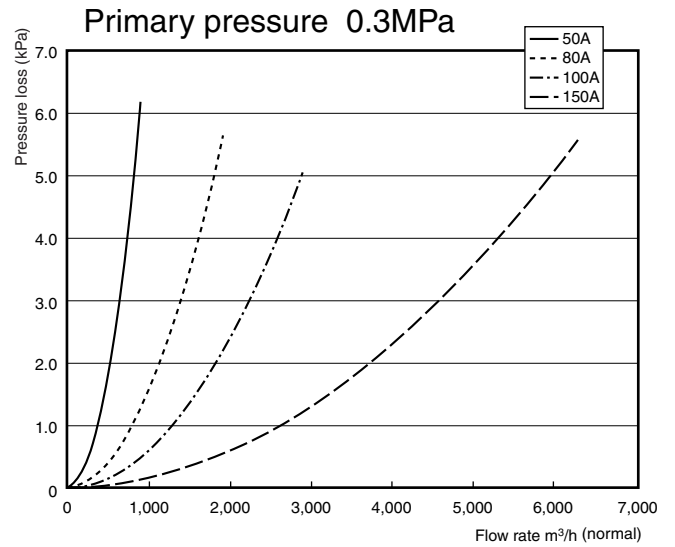
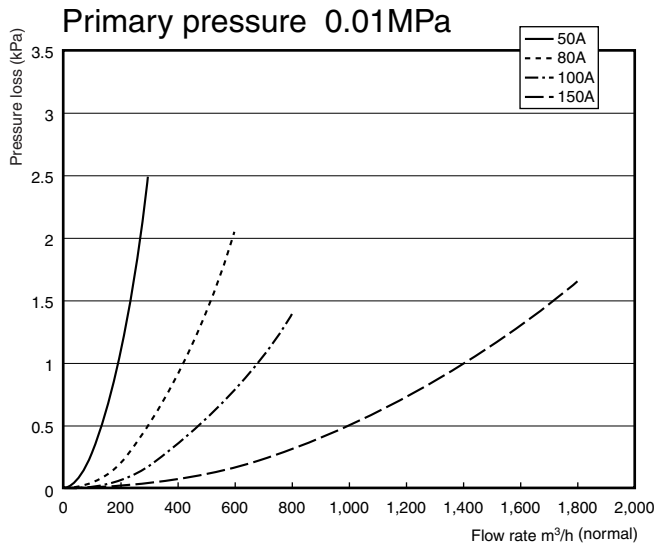

When the MVF is used for a gas other than air, multiply by the appropriate specific gravity below:

| Specific Gravity of Each Gas (when air is 1.0) | |
|--|------|
| Argon | 1.38 |
| Carbon dioxide | 1.53 |
| Oxygen | 1.11 |
| Natural gas (LNG base) | 0.64 |
| Methane, 100% | 0.56 |
| Propane, 100% | 1.56 |
| Butane, 100% | 2.08 |

Example: In the case of the MVF150 model, with a primary pressure of 0.9MPa and a flow rate of 6000m³/h (normal), the pressure loss of Natural gas can be calculated as follows:

- From the graph for 0.9MPa primary pressure, the pressure loss is 2kPa at a flow rate of 6000m³/h (normal). When this is multiplied by the specific gravity of city gas 13A, 0.64, the pressure loss is:

$$2\text{kPa} \times 0.64 = 1.28\text{kPa}$$

■ Installation Method and Installation Precautions

● Bypass piping

When this device is installed, be sure to provide bypass piping as shown below. Also, for the valves upstream and downstream of this device, use ball valves, which have a structure that does not disturb the gas flow.

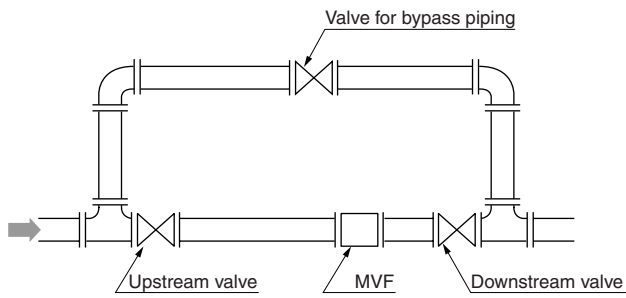

● Straight pipe section

Provide a straight pipe section on the upstream side and downstream side of the installation location. Refer to the drawings below for the length of the straight pipe sections. D indicates the connecting port size. Be sure that the downstream pipe section is more than $5D$ in length.

Regarding pipe size, use Sch 20 for 50A, and Sch 40 for 80A/100A/150A.

If some pipe other than those listed above is used, make sure that the pipe's inner diameter is within the range given below for each pipe size.

50A: 53 to 55 mm dia.

80A: 78 to 81 mm dia.

100A: 97 to 102 mm dia.

150A: 143 to 151 mm dia.

| Installation | Condition |
|---|-----------|
| Reducing pipe | |
| Enlarging pipe | |
| Pipe with 90° bend | |
| Pipe with single-plane double 90° bend | |
| Pipe with a three-dimensional double 90° bend | |

● Filter installation

If the fluid contains oil, water or dust, install a filter to remove them on the upstream side; otherwise they might cause measurement error or faulty operation.

- Remove water with a dryer so that it does not cause dew condensation in the pipe.
- Use a dust-eliminating filter with a mesh of less than 1 micrometer in diameter.
- Use an oil-eliminating mist separator that can eliminate residual oil droplets less than $0.01\text{mg}/\text{m}^3$ in size.

● **Precautions for MVF installation**

- If this device is installed in locations subject to direct sunlight, be sure to provide a sunshade. Although this device can be installed outdoors, direct sunlight might cause an error or faulty operation.
- Do not install the device where it will receive a pulsating flow.
- Do not measure flow rate near the exit of a compressor.

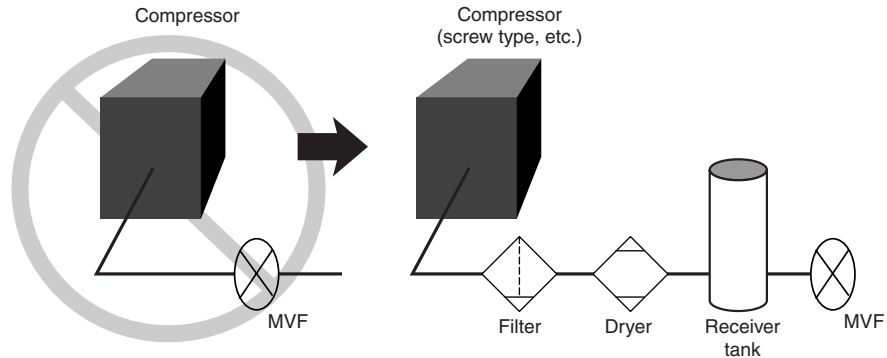

In a location near the exit of a compressor, there is a strong pulsating flow and possibly dispersed iron powder (depending on the compressor type), which may cause faulty operation. As shown in the above figure, provide devices that eliminate oil, water or iron powder on the upstream side, and install the MVF at the downstream side of a receiver tank as a countermeasure against pulsating flow.

- If this device is installed near a pump or Roots blower, it may be affected by a pulsating flow. Install a volume tank or pulsation-damping device (muffler) between the pump or Roots blower and this device to suppress the influence of pulsation as much as possible.
- If this device is installed on the downstream side of branched piping, reverse flow rate might be detected. Be sure to take countermeasures as illustrated below.

Example:

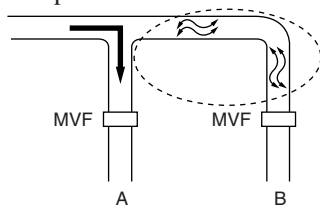

In this application, the A-line is operating but B is stopped.

Although the flow rate of B is essentially zero as detected by the MVF in B, the MVF might count and integrate a false flow rate caused by the influence of the flow in A.

Countermeasure 1.

Install a valve on the upstream side of the MVF if there is an unused line to eliminate the influence of flow in the other line.

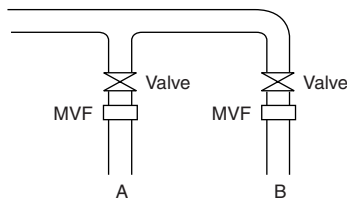

Countermeasure 2.

Design the system so that the other devices do not receive the output (4 to 20mA pulse) from the MVF on the unused line.

Please read the "Terms and Conditions" from the following URL before ordering or use:

<http://www.yamatake.com/products/bi/order.html>

Specifications are subject to change without notice.

azbil

Yamatake Corporation
Advanced Automation Company

1-12-2 Kawana, Fujisawa
Kanagawa 251-8522 Japan
URL:<http://www.azbil.com>

1st Edition: Issued in Mar. 2006
4th Edition: Issued in Feb. 2010

*No part of this publication may be reproduced or duplicated
without the prior written permission of Yamatake Corporation.*