

azbil



Massflow Sensor MCS100



New proposal for chip pickup detection

Miniature chips being picked up can be detected by Yamatake's original μ F (Micro Flow) sensor.

Compact and lightweight (only 9g!)

Reverse flow measurement possible due to its symmetrical structure

- Can be installed very near to the pickup nozzle.
- 5ms high-speed response for detection of high speed tact pickup
- Not influenced by fluctuations in suction pressure because of mass flow measurement
- Filter clogging and nozzle deformation detectable by analog output

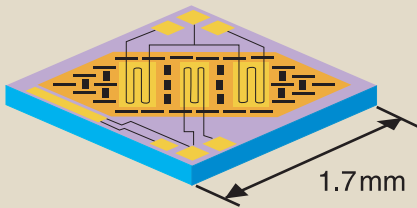

Direct measurement with flow sensor

● Installation examples

- Pickup head using an ejector

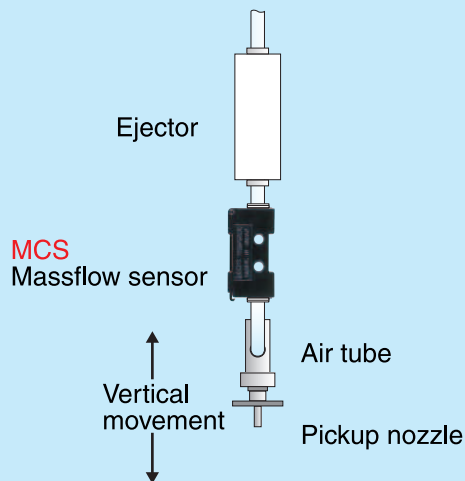

- Pickup head with gang-mounted nozzle (w/ vacuum pump)

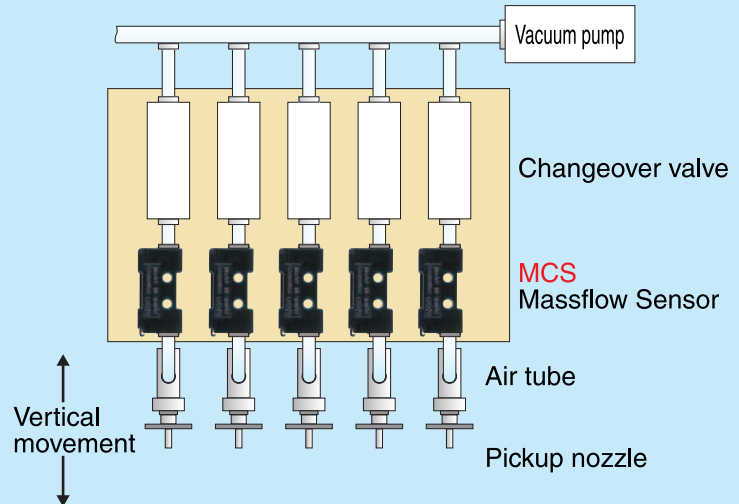

1 5ms high-speed response by a μ F (Micro Flow) sensor of Yamatake's original technology

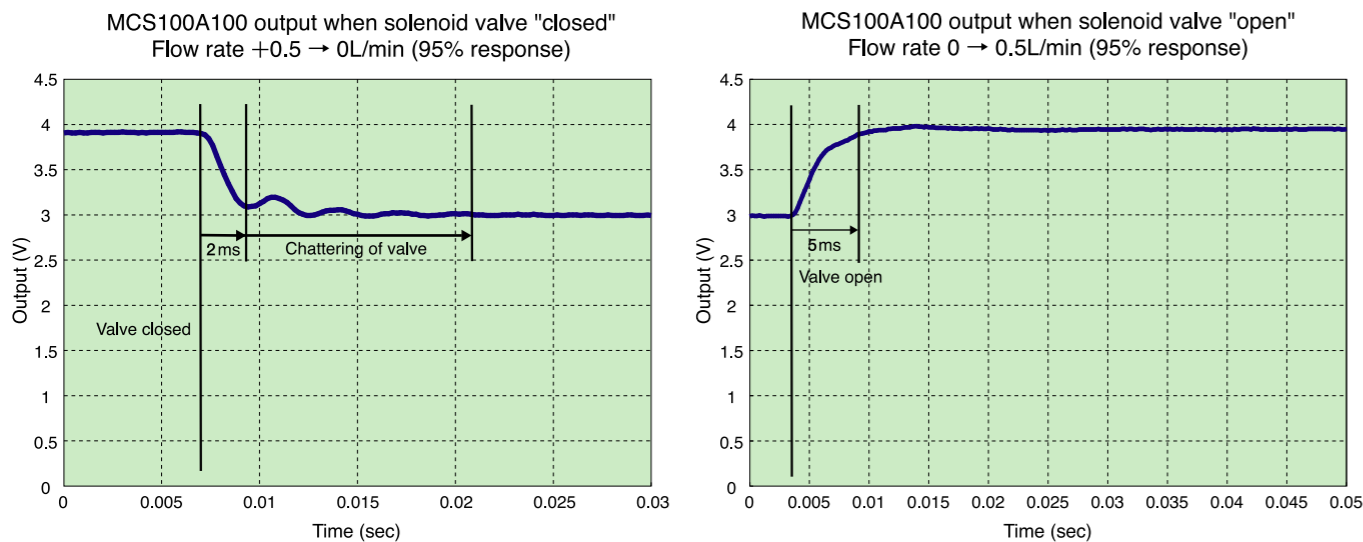

2 A larger output differential can be secured between pickup and non-pickup conditions when comparing with a standard pressure sensor.

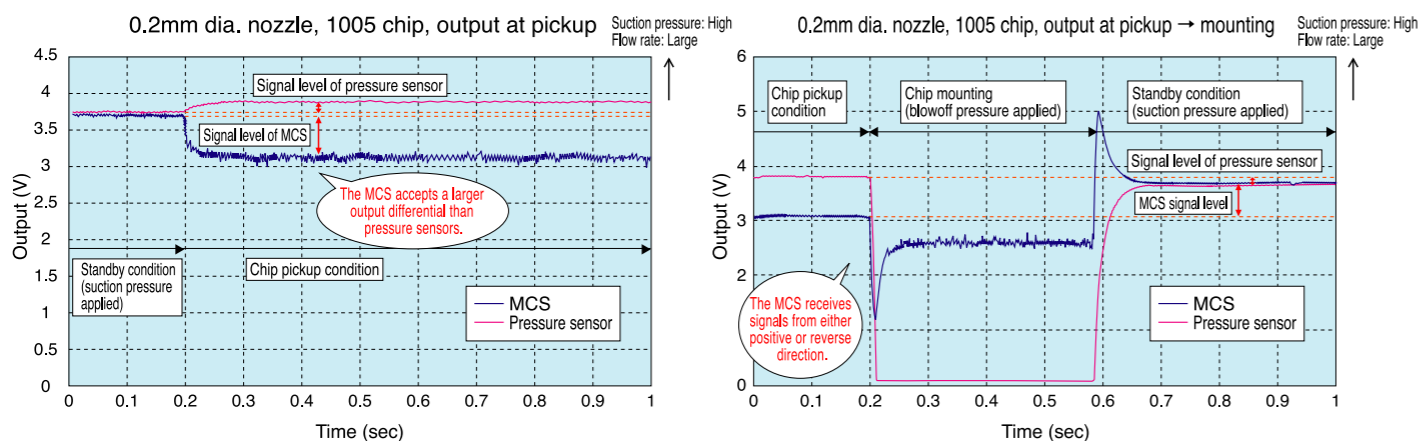

3 Compact and lightweight allows the flow sensor to be installed anywhere and also just above the nozzle (direct mounting onto the air tube between nozzle and ejector), enabling the high response for detection of pickup.



4 Accurate detection is ensured by the MCS' unique flow rate measurement system which is not influenced by suction pressure fluctuations* like pressure sensors are.

Note: *Fluctuations are caused by supply pressure to an ejector or the load changes in vacuum pump (or pickup conditions of other nozzle in a multiple nozzle system).

5 Single setup control is possible at controller side due to an analog output signal even if pickup nozzle is changed. Filter clogging or nozzle deformation can be detected with flow rate at non-pickup state.

6 Both pickup and bringing-back of chip in the mounting process can be detected because the flow in both positive and reverse directions can be detected.

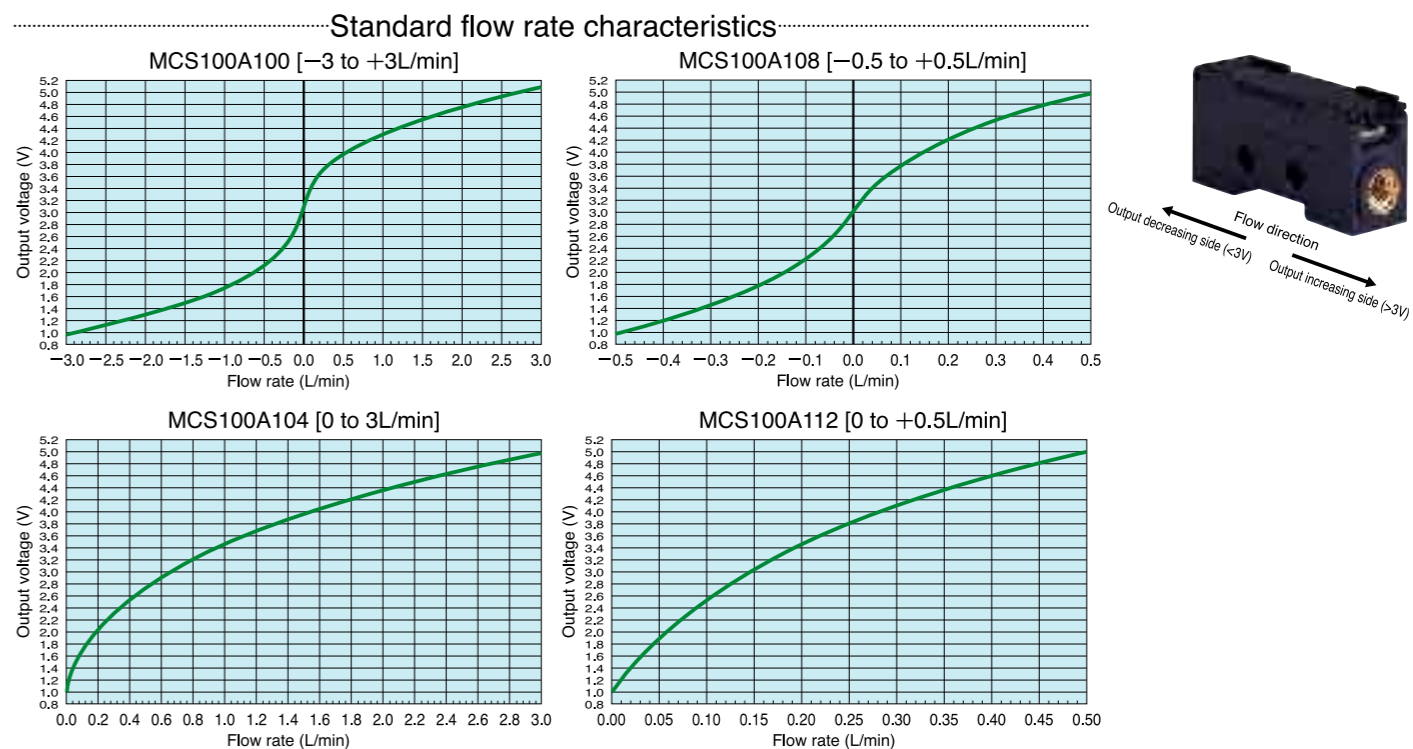

Connection

View from connector terminal side

Pin No.	Signal name	Description
1	V+	Power supply +
2	GND	GND
3	Vout	Sensor output

Applicable connector: SHR-03V-S-B made by J.S.T. Mfg Co. Ltd.
Contact pin: SSH-003GA-P0.2 made by J.S.T. Mfg Co. Ltd.

Note: Not insulated between inputs and outputs

Recommended connection example

Note: Allowable load resistance is 10k Ω min.

Estimating flow rate

The flow rate passing through a nozzle can be approximated from the nozzle diameter and nozzle's internal pressure. This value should only be used as a reference when determining the flow range for a flow sensor.

- If P_2 (nozzle's internal pressure) is lower than -50kPa (flow rate = sonic velocity), the flow rate which may pass through nozzle $Q = 12 \times S$.
- If P_2 (nozzle's internal pressure) is -49 to 0kPa , the flow rate which may pass through nozzle $Q = 0.24 \times S \times \sqrt{-P_2(101 + P_2)}$.

Q: Estimated flow rate for nozzle (L/min)
 P_2 : Nozzle's internal pressure (kPa, gauge pressure)
 S: Diameter of nozzle tip

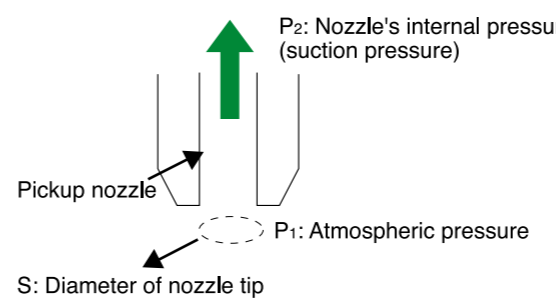

Example: Estimating the flow rate (L/min)

P_2 (kPa) nozzle's internal pressure	Flow velocity	Nozzle diameter (mm)				
		0.1 dia.	0.2 dia.	0.3 dia.	0.4 dia.	0.5 dia.
-20	—	0.08	0.30	0.68	1.21	1.90
-30	—	0.09	0.35	0.78	1.39	2.17
-40	—	0.09	0.37	0.84	1.49	2.33
-50	Sonic velocity	0.09	0.38	0.85	1.51	2.36
-60	Sonic velocity	0.09	0.38	0.85	1.51	2.36
-70	Sonic velocity	0.09	0.38	0.85	1.51	2.36
-80	Sonic velocity	0.09	0.38	0.85	1.51	2.36

Note: If any leakage occurs along the piping, the actual flow rate may be greater than the flow rate which was estimated.

Specifications

Model No.	MCS100A100	MCS100A104	MCS100A108	MCS100A112
Flow range	-3 to +3L/min	0 to 3L/min	-0.5 to +0.5L/min	0 to 0.5L/min
Applicable gas	Air and Nitrogen. Gas must be dry not containing any corrosive components (chlorine, sulfur, acid). The gas must also be free of any dust or oil mist.			
Response	5ms max. (95% response to a step state flow rate changing)			
Output signal	1 to 5Vdc (non-linear characteristics, refer to the standard output characteristics graph), allowable load resistance 10kΩ or more			
Operating temperature range	0 to 50°C (for both ambient temperature and gas temperature)			
Storage temperature	-10 to +60°C			
Operating humidity range	10 to 80%RH (no condensation allowed)			
Operating pressure range	-100 to +200kPa (Range for assured pressure characteristics: -70 to +200kPa)			
Pressure resistance	300kPa			
Measurement accuracy	±5%FS max.	±5%FS max.	±5%FS max.	±6%FS max.
Typical characteristics of output voltage	Output voltage 4V (5 to 1V) for full scale			
	0.0L/min: 3.00±0.15V	0.0L/min: 1.00±0.20V	0.0L/min: 3.00±0.20V	0.0L/min: 1.00±0.24V
	0.5L/min: 3.88±0.15V	0.5L/min: 2.75±0.15V	0.1L/min: 3.77±0.20V	0.1L/min: 2.54±0.24V
	1.5L/min: 4.49±0.15V	1.5L/min: 3.97±0.24V	0.3L/min: 4.53±0.20V	0.3L/min: 4.06±0.24V
	3.0L/min: 5.00±0.20V	3.0L/min: 5.00±0.20V	0.5L/min: 5.00±0.20V	0.5L/min: 5.00±0.24V
Repeatability	±3.5%FS max.	±7.0%FS max.	±2.0%FS max.	±2.0%FS max.
Pressure characteristics	Under the same temperature and pressure conditions. Output voltage 4V (5 to 1V) for full scale.			
	±0.01%FS/kPa	±0.02%FS/kPa	±0.01%FS/kPa	±0.02%FS/kPa
	Pressure range: -70 to +200kPa			
Temperature characteristics	Full scale is to the output voltage 4V under the conditions of 20°C and 1 atm. (101.325kPa abs.).			
	0.0L/min: ±0.1%FS/°C	0.0L/min: ±0.1%FS/°C	0.0L/min: ±0.1%FS/°C	0.0L/min: ±0.2%FS/°C
	1.5L/min: ±0.15%FS/°C	1.5L/min: ±0.15%FS/°C	0.3L/min: ±0.15%FS/°C	0.3L/min: ±0.2%FS/°C
	Temperature range: 0 to 50°C			
Power supply voltage	12 to 24Vdc, Ripple:5%max.at 12Vdc drive and 10% max.at 24Vdc drive.(Note 2)			
Power fluctuation range	When 12Vdc drive: ±2%FS max. to the output value at 12Vdc within the range of 11.4 to 13.2Vdc. When 24Vdc drive: ±2%FS max. to the output value at 24Vdc within the range of 21.6 to 26.4Vdc.			
Current consumption	12mA max. at 24Vdc			
Dielectric strength	500Vac (1 min) or 600V (1sec) between each external connector terminal and body			
Insulation resistance	50MΩ (500Vdc megger) between each external connector terminal and body			
Connection type	M5 female (brass insertion), tightening torque 2.5N·m max.			
Material	Parts exposed to gas: PPS resin, ceramic (printed wiring board) and brass (connecting part) Cover: PC (Polycarbonate) resin			
Mounting position	Free			
Mounting conditions	When using the mounting holes of body, use M3 screws and tighten with 0.6N·m max. torque. Install a filter in upstream side of this device to trap the dust or oil mist of 10μm or larger.			
Straight piping length	Not required for both upstream and down stream sides			
Vibration resistance	10 to 55Hz, 1.5mm peak-to-peak amplitude, 2 hours each in XYZ directions			
Weight (mass)	9g			
Electronic connection (Dedicated connector connection)	Cable with dedicated connector (sold separately) : 81446888-001 (2m), 81446888-002 (3m) MCS side : SM03B-SRSS-G-TB manufactured by J.S.T.Mfg Co. Ltd., Counterpart side : SHR-03V-S-B (housing) and SSH-003GA-P.2 (contact) manufactured by the same company.			

Note 1: For the %FS in the above description, 4V of output voltage (1-5V) is specified as a full-scale.

Note 2: When used at 24Vdc drive, the output change may occur within ±1%FS max. after flowrate stabilization in the vicinity of measurement range upper limit flowrate (the amount of drift after 500s from the flowrate stabilization).

Dimensions

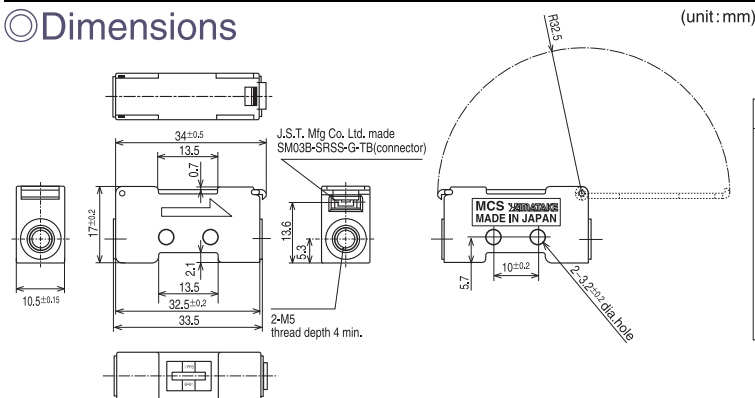

RESTRICTIONS ON USE

This product has been designed, developed and manufactured for general-purpose application in machinery and equipment. Accordingly, when used in applications outlined below, special care should be taken to implement a fail-safe and/or redundant design concept as well as a periodic maintenance program.

- Safety devices for plant worker protection
- Start/stop control devices for transportation and material handling machines
- Aeronautical/aerospace machines
- Control devices for nuclear reactors

Never use this product in applications where human safety may be put at risk.

Specifications are subject to change without notice.

Yamatake Corporation Advanced Automation Company

1-12-2 Kawana, Fujisawa
Kanagawa 251-8522 Japan
URL: <http://www.azbil.com>

Printed in Japan.(MO)
1st Edition: Issued in Mar.2003
3rd Edition: Issued in May.2005

No part of this publication may be reproduced or duplicated without the prior written permission of Yamatake Corporation.