

azbil

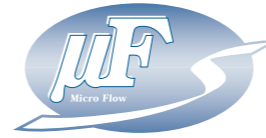

Air Flowmeter Model : MCF



Air Flowmeter Model: MCF

A superb way to save energy when using compressed air or nitrogen.



www.azbil.com

Please read the "Terms and Conditions" from the following URL before order or use:

<http://www.yamatake.com/products/bi/order.html>

Specifications are subject to change without notice.

Yamatake Corporation
Advanced Automation Company

1-12-2 Kawana, Fujisawa
Kanagawa 251-8522 Japan
URL:<http://www.azbil.com>

azbil

Printed in Japan (ST)
1st Edition: Issued Feb. 2008
4th Edition: Issued in Nov. 2009

No part of this publication may be reproduced or duplicated without the prior written permission of Yamatake Corporation.



Features of the MCF air flowmeter



A dedicated air/nitrogen mass flowmeter, indispensable for cutting compressor energy use.

■ Practical measurement range of 50:1 and extended range function providing up to 2 times the standard range are useful for detecting air leakage

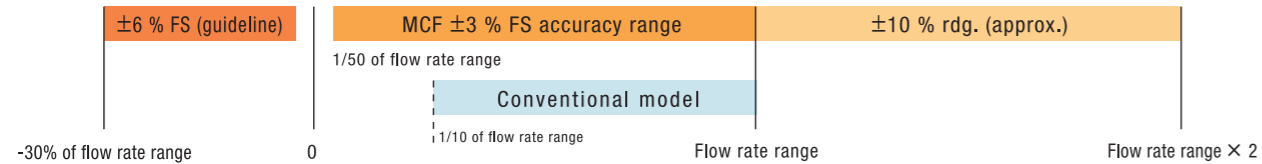

Reverse flow detection function

Useful for loop piping. Reverse flow detection and forward-reverse flow integration functions are provided.

*Reverse flow measurement range is up to 30% of forward flow rate measurement range.

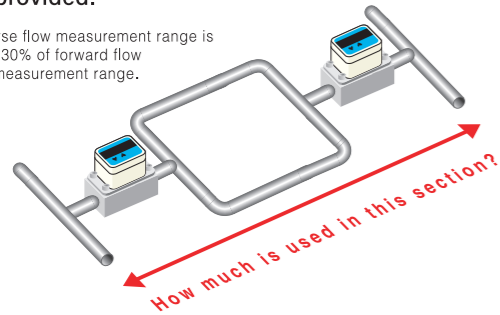

Model lineup meets a variety of application requirements

For ease of use and ease of selection, models in a broad range from small to large are available.

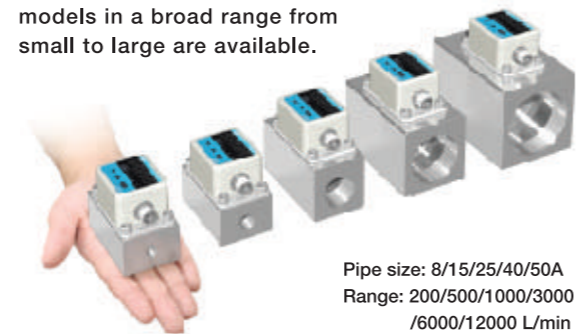

Easy maintenance without removal from the piping

The measurement unit can be dismantled and replaced for easy maintenance at the application site without disconnecting the pipes.

(Pipe sizes 25/40/50A only)



Use a single MCF for flow in various directions

The display unit can rotate more than 90° counterclockwise and more than 180° clockwise.

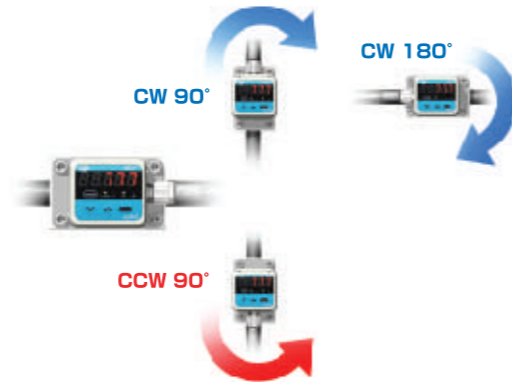

The MCF is a mass flowmeter.

Thermal mass flow measurement using Yamatake's Micro Flow (μF) sensor ensures correct measurement even if gas temperature or pressure changes.

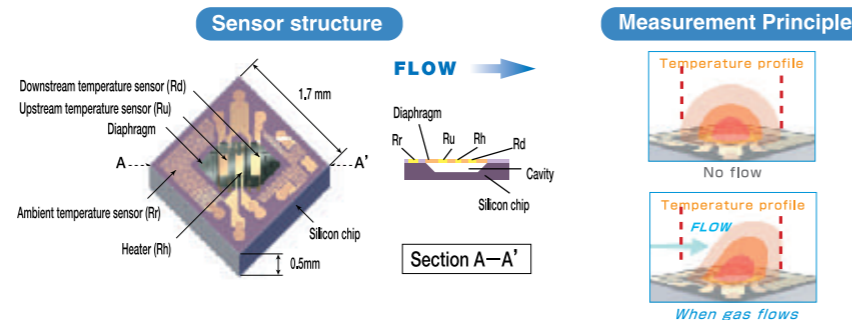

Application examples

Detecting air leakage



Substantial reduction of air leakage by determining the leakage quantity — generally said to be around 30% — and repairing the leaks.

Leakage check method

- 1 Read the instantaneous flow rate from the flowmeter.
- 2 Plot the instantaneous flow rate using a PC.

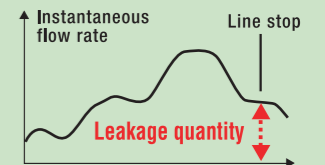

Cost management for production line or whole department



Knowing the total flow quantity and cost for an area, and budgeting by area, is sure to increase cost consciousness and enable measurement of cost reduction efforts.

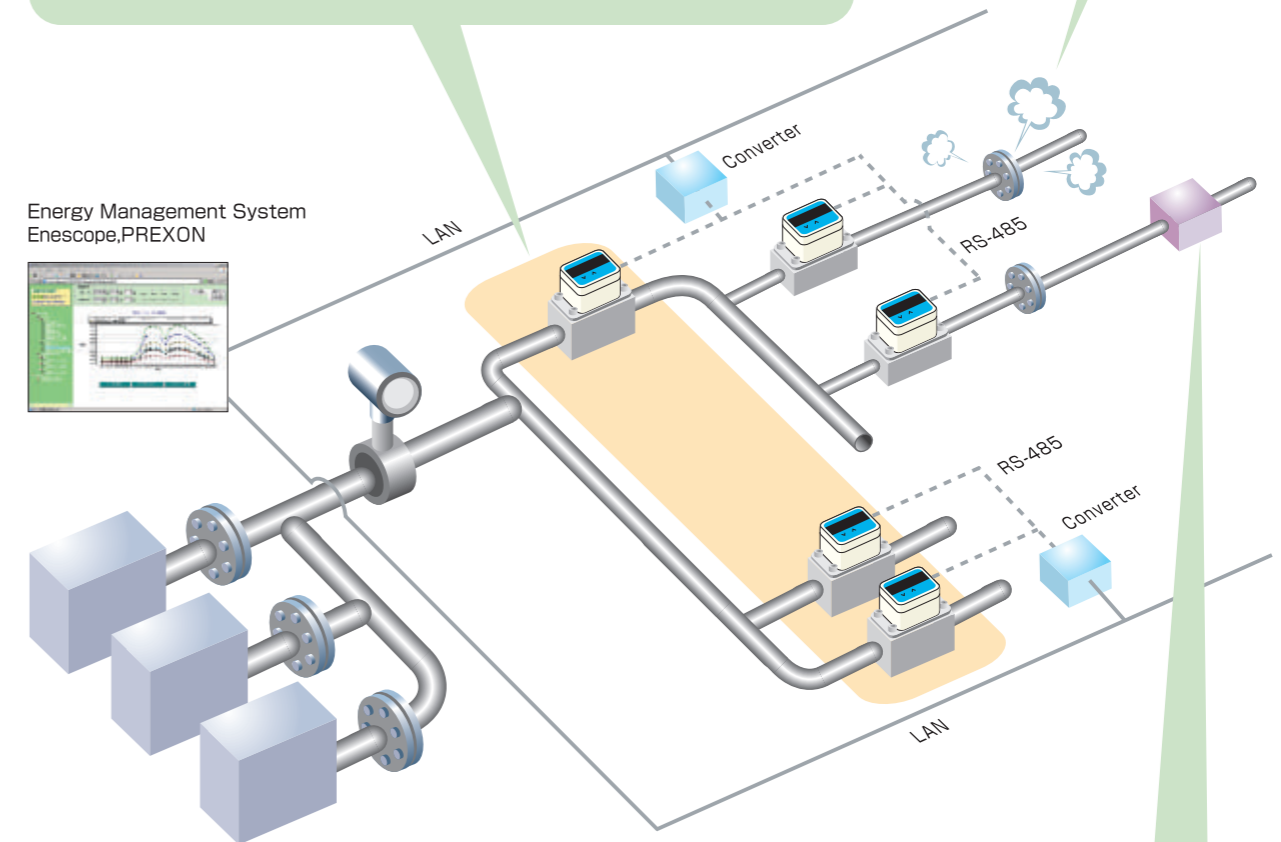

Supply of appropriate quantities

Since the air quantity used by equipment can be checked to know if it is appropriate, waste can be reduced by restricting the air supply to an appropriate quantity.

Specifications

Model No.	MCF0080	MCF0150	MCF0151	MCF0250	MCF0400	MCF0500
Gas types	Air/nitrogen. (Note that gas must be dry, without corrosive components such as chlorine, sulfur and acid. It must also be clean, without dust or oil mist.)					
Flow rate range [L/min(normal)] *1	0 to 200	0 to 500	0 to 1000	0 to 3000	0 to 6000	0 to 12000
Reverse flow range [L/min(normal)] *2	-60	-150	-300	-900	-1800	-3600
Extended range [L/min(normal)] *3	400	1000	2000	6000	12000	24000
Accuracy guaranteed flow rate range [L/min(normal)] *4	4 to 200	10 to 500	20 to 1000	60 to 3000	120 to 6000	240 to 12000
Measurement accuracy	± 3% FS					
Smallest detectable flow rate [L/min(normal)]	2	5	10	30	60	120
Display resolution [L/min(normal)]	1	1	2	5	10	10
Flow rate units	MCF□□□□□R MCF□□□□□G : L/min(normal),L MCF□□□□□N : CFH,CF					
Temperature	-10 to +60 °C (without freezing)					
Storage temperature	-20 to +70 °C (without freezing)					
Humidity	0 to 90 % RH (without condensation)					
Pipe size	8A(1/4B)	15A(1/2B)	15A(1/2B)	25A(1B)	40A(1 1/2B)	50A(2B)
Body material	Aluminum alloy					
Case material	Denatured PPO					
O-ring material	MCF□□□□□A : H-NBR MCF□□□□□F : FKM					
Operating pressure range	-0.07 to +1.0 MPa					
Pressure resistance	1.5 MPa					
Mounting orientation	· Horizontal (flow: left → right, right → left) · Vertical (flow: up → down, down → up)					
Rated voltage	24 Vdc, 120 mA max.					
Sampling cycle/ response time	50 ms to 1.5 s max. (time for 95 % of response to 0 → 100 % FS step input)					
Output signal (instantaneous flow rate)	4 to 20 mA, allowable load resistance 300 Ω max.					
Event output	One open collector output (rating 30 Vdc, 50 mA), with output type selectable from event function.					
Event function	Selectable from pulse output for integration *5, instantaneous flow rate high/low limit alarm, integration count up/down, or alarm output.					
Communications	RS-485 Communications (3-wire system), MODBUS Protocol Transmission speed 19200 bps max.					
Electrical connection	PA5 Series VA connector (4 pins)					
Display	7-segment, 5-digit display changeable between instantaneous flow rate, integrated (cumulative) flow, and cost.					
Protective structure	IP65. (Rating is based on JIS C 0920 and IEC529. For purposes of installation indoors, device is waterproof and dustproof.)					
Standards compliance	CE marked : EN61326-2-3 : 2006					
Mass	400 g	400 g	400 g	500 g	700 g	1100 g

Notes: *1. The unit L/min (normal) refers to the volumetric flow rate adjusted for 0 °C, 101.325 kPa. *2. Flow is displayed as a negative value even if the setting is not changed. *3. Indication value and integrated pulse output can be displayed and output even if the setting is not changed, but 4-20 mA output requires a change of the span setting. *4. The guaranteed accuracy range figures are ± 3% FS. *5. Integrated pulse output specifications (selectable by settings)
 · Pulse width: 50 ms, 250 ms, 500 ms
 · Pulse weight:

Model No.	Pulse weight (L/pulse)	Model No.	Pulse weight (L/pulse)
MCF0080	10, 100, 1000	MCF0250	10, 100, 1000
MCF0150	10, 100, 1000	MCF0400	100, 1000, 10000
MCF0151	10, 100, 1000	MCF0500	100, 1000, 10000

Selection guide

MCF

Basic model no	Pipe size/range	Material	Connection	Gas type	Power/output	Option	Option	Option	Design code	Description
MCF										Air flowmeter MCF
	0080									8A(1/4B) · 200L/min
	0150									15A(1/2B) · 500L/min
	0151									15A(1/2B) · 1000L/min
	0250									25A(1B) · 3000L/min
	0400									40A(1 1/2B) · 6000L/min
	0500									50A(2B) · 12000L/min
		A								Body : aluminum alloy O-ring:H-NBR
		F								Body : aluminum alloy with treated to be oil inhibiting,O-ring : fluororubber(FKM)
			R							Rc thread
			N							NPT thread
			G							G thread
				N						Air/Nitrogen
					D01					24 Vdc / 4-20 mA output / one open collector
					D10					24 Vdc / RS-485 communication / none outputs
						0				(None)
							0			(None)
								0		(None)
								D		Inspection certificate provided
								Y		Traceability certificate
									0	Product version

Accessories (sold separately)

· PA5 Series connector cables

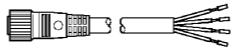
Shape	Power	Cable properties	Cable length	Model No.	Lead color
	DC	Oil resistant, bend-tolerant UL2464 Flame-resistant cable EN-compliant.	2 m	PA5-4ISX2MK-E	1: Brown. 2: White. 3: Blue. 4: Black.
			5 m	PA5-4ISX5MK-E	1: Brown. 2: White. 3: Blue. 4: Black.

Note: Types other than the above are available. Please contact Yamatake Corporation.

· Mounting bracket (for MCF0080/0150/0151/0250)

Model No.
81446721-001

· Mist Separator MFF25S Series

Selection guide

Basic model No.	Type	Pipe size + treated flow rate	Design code	Description
MFF25S				Mist separator for MCF models
	N			Housing + element
				Pipe size Treated flow rate
		080300	8A(1/4B)	300 L/min For MCF0080
		080750	8A(1/4B)	750L/min
		150750	15A(1/2B)	750L/min For MCF0150
		151500	15A(1/2B)	1500L/min For MCF0151
		254000	25A(1B)	4000L/min For MCF0250
		256000	25A(1B)	6000L/min
			000	None

Options

Name	Model No.	Notes
Replacement filter element	81441628-001	For MFF25SN080300000
	81441628-002	For MFF25SN080750000, For MFF25SN150750000
	81441628-003	For MFF25SN151500000
	81441628-004	For MFF25SN254000000
	81441628-005	For MFF25SN256000000
Mounting bracket	81441629-001	For MFF25SN080300000
	81441629-002	For MFF25SN080750000, For MFF25SN150750000, For MFF25SN151500000
	81441629-003	For MFF25SN254000000, For MFF25SN256000000

· Mist Separator MFF25L Series

Selection guide

Basic model No.	Type	Pipe size + treated flow rate	Design code	Description
MFF25L				Mist separator for Micro Flow products
	N			Housing + element
				Pipe size Treated flow rate
		406600	40A(1/2B)	6600L/min For MCF0400
		501380	50A(2B)	13800L/min For MCF0500
			000	None

Options

Name	Model No.	Notes
Replacement filter element	81441630-001	For MFF25LN406600000
	81441630-002	For MFF25LN501380000

External dimensions (Unit: mm)

MCF

MCF0080

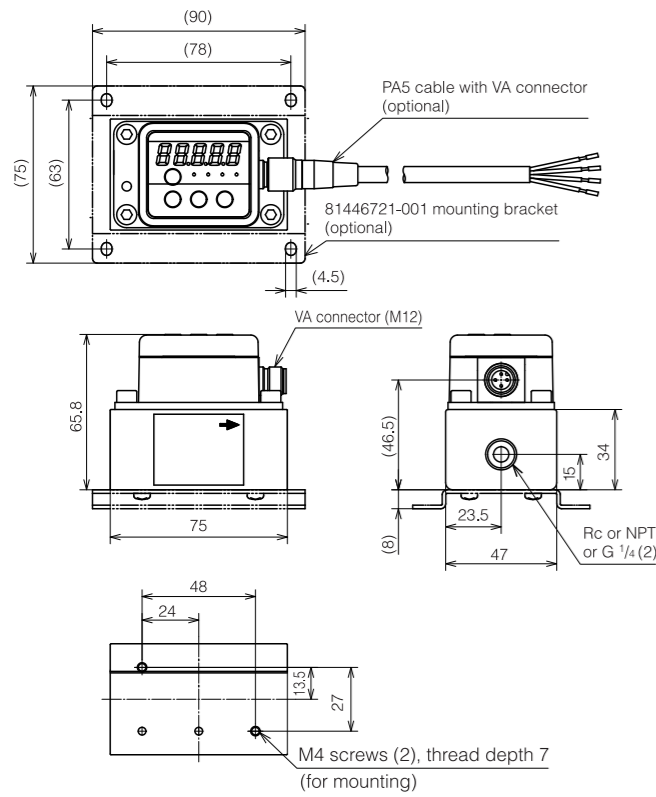

MCF0150 / MCF0151

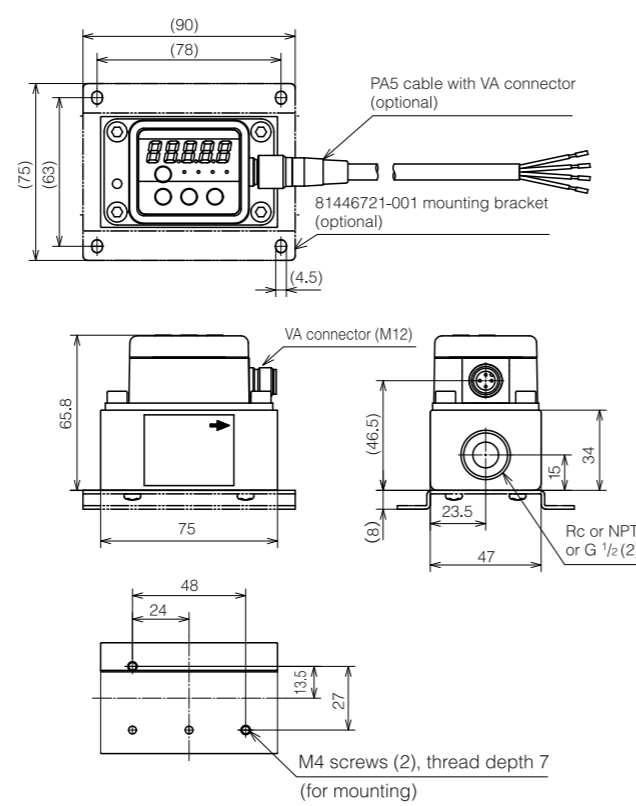

MCF0500

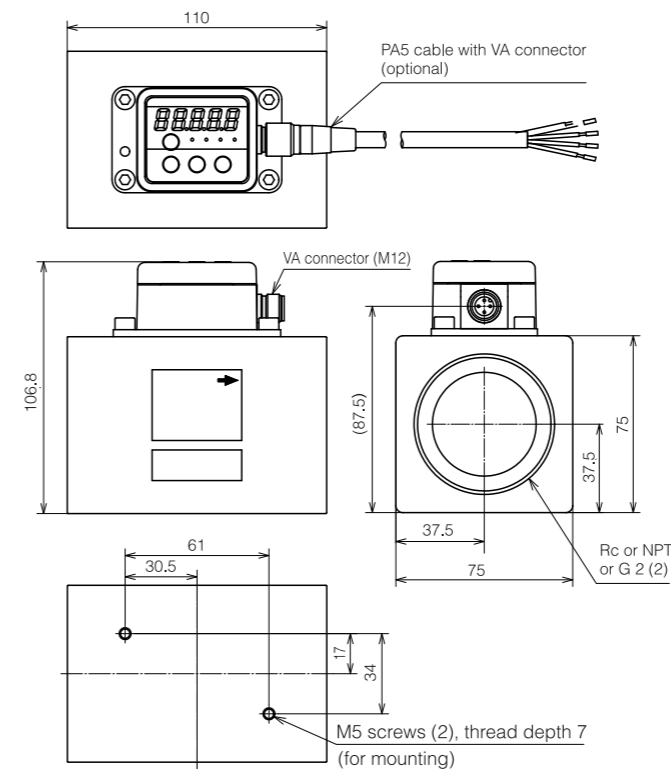

Mounting bracket, (for MCF0080/0150/0151/0250)

81446721-001

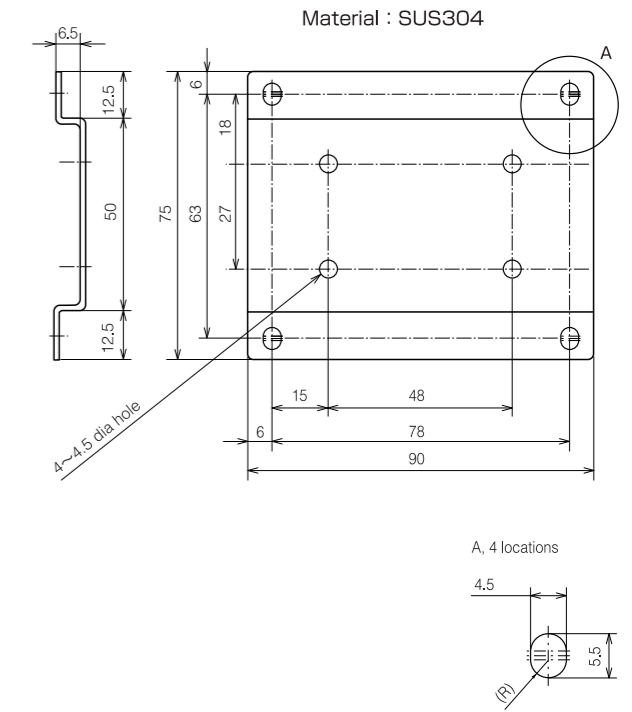

MCF0250

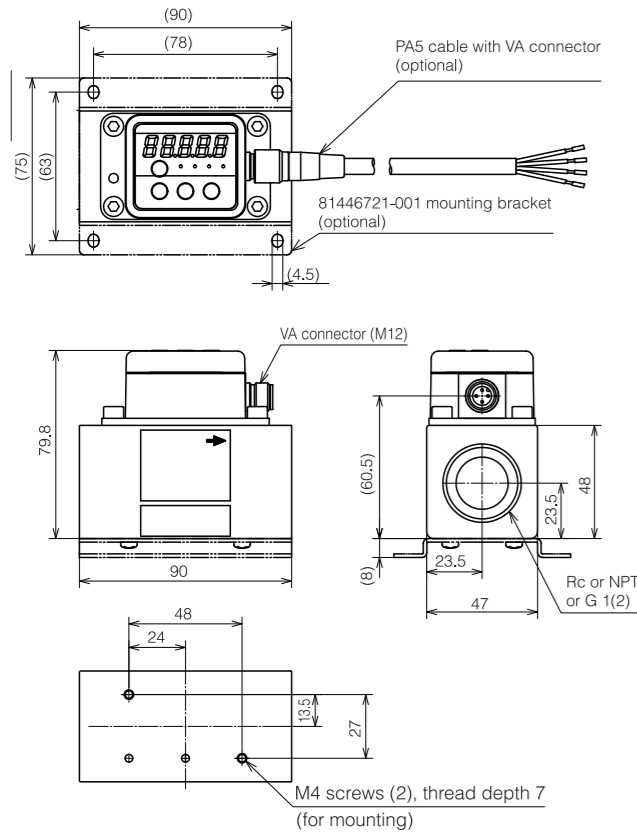

MCF0400

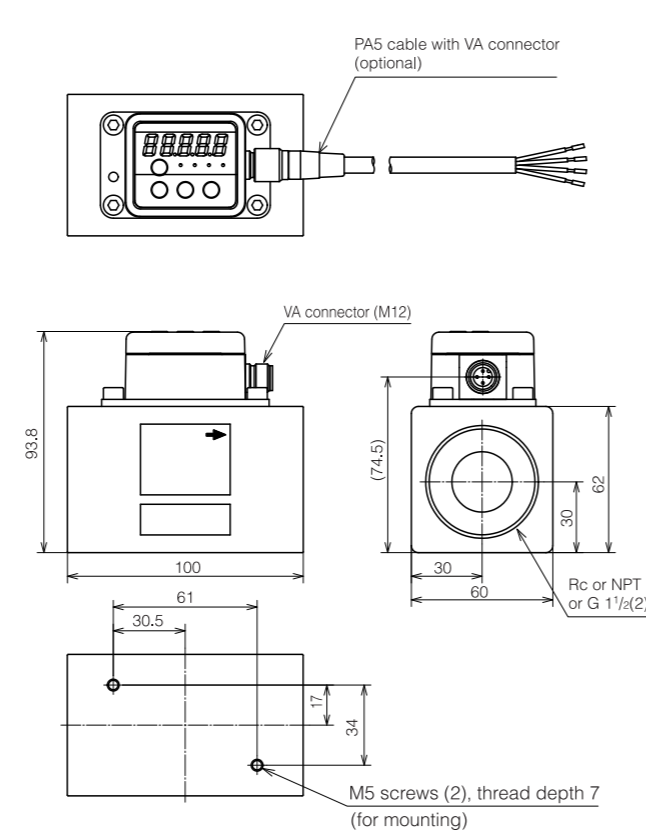

Wiring pin assignment

(1) MCF□□□□□□□□ND01□□□□
4-20mA, open collector output

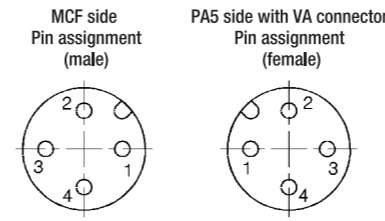

Connector pin No.,
PA5 lead color, and signal
1: Brown·····24 Vdc
2: White·····4 to 20 mA output
3: Blue·····COM
4: Black·····Event output

(2) MCF□□□□□□□□ND10□□□□
(RS-485)

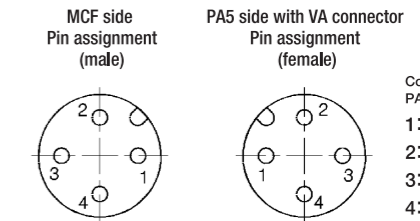

Connector pin No.,
PA5 lead color, and signal
1: Brown·····DC24V
2: White·····RS485(DB)
3: Blue·····COM / SG
4: Black·····RS485(DA)

Wiring example

(1) MCF□□□□□□□□ND01□□□□
4-20mA, open collector output

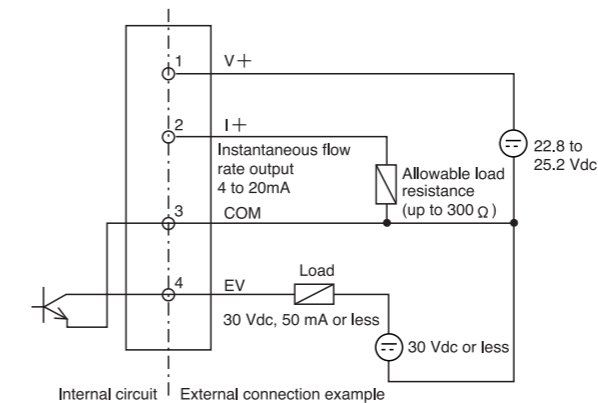

(2) MCF□□□□□□□□ND10□□□□
(RS-485)

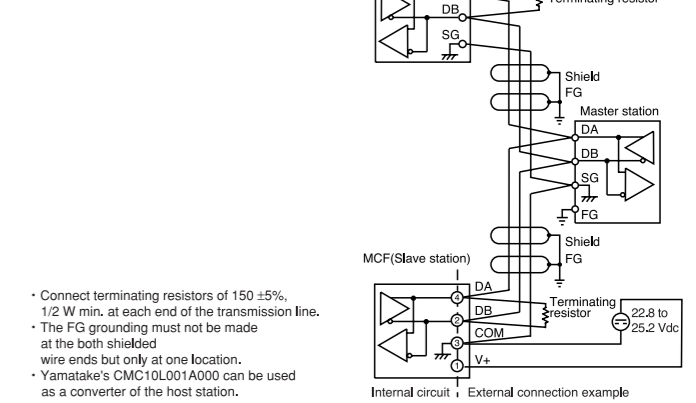

- Connect terminating resistors of 150 ±5%, 1/2 W min. at each end of the transmission line.
- The FG grounding must not be made at the both shielded wire ends but only at one location.
- Yamatate's CMC10L001A000 can be used as a converter of the host station.

Mist Separator External dimensions (Unit: mm)

MFF25S Series

MFF25S

MFF25SN080300000

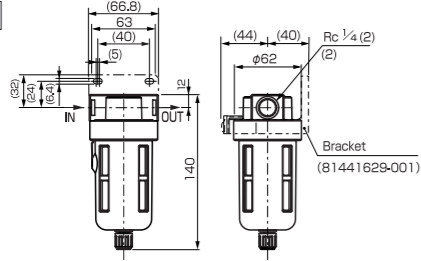

MFF25SN080750000
MFF25SN150750000
MFF25SN151500000

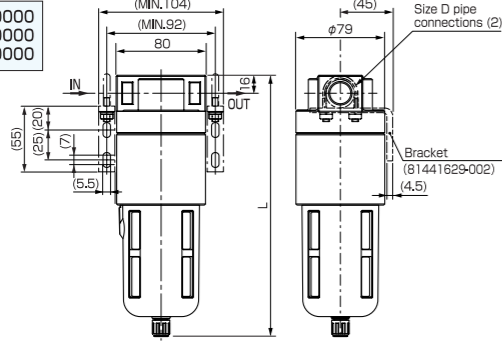

Model No.	L	D
MFF25SN080750000	167.5	Rc1/4
MFF25SN150750000		Rc1/2
MFF25SN151500000	231	

MFF25SN254000000
MFF25SN256000000

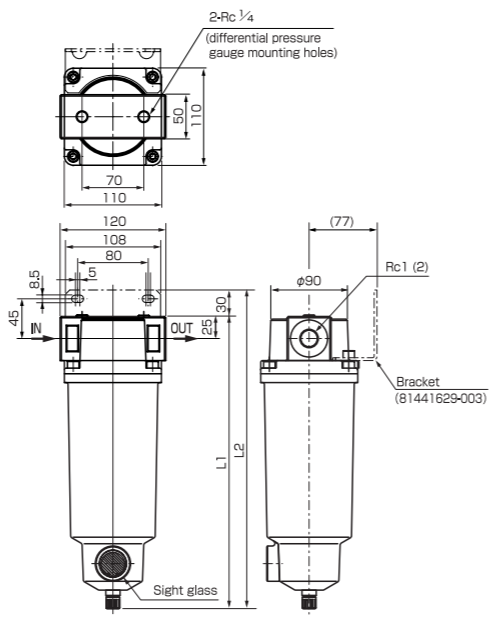

Model No.	L1	L2
MFF25SN025400000	253.5	283.5
MFF25SN025600000	331.5	361.5

Filter element

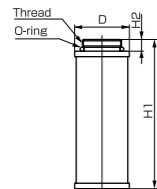

Model No.	H1	H2	D	Thread	Notes
81441628-001	65	10	φ35	M22X1.5	For MFF25SN080300000
81441628-002	78	12	φ48	M32X1.5	For MFF25SN080750000, MFF25SN150750000
81441628-003	127	12	φ48	M32X1.5	For MFF25SN151500000
81441628-004	110	15	φ70	M50X2	For MFF25SN254000000
81441628-005	191	15	φ70	M50X2	For MFF25SN256000000

Bracket

81441629-001
(For MFF25SN080300000)

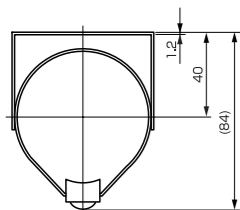

81441629-002
(For MFF25SN080750000, MFF25SN150750000, MFF25SN151500000)

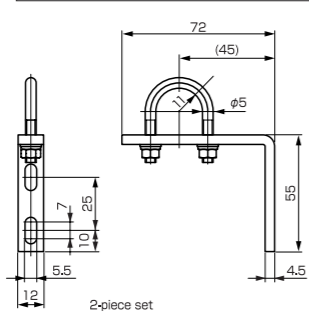

81441629-003
(For MFF25SN254000000, MFF25SN256000000)

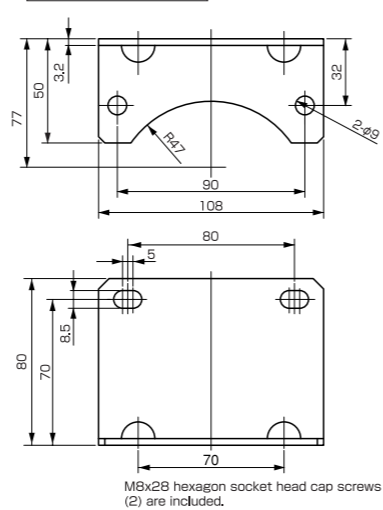

MFF25L Series

MFF25LN406600000

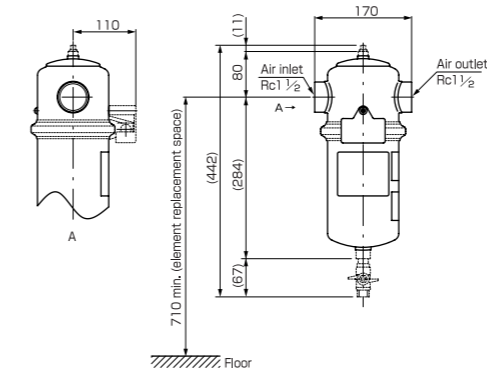

MFF25LN501380000

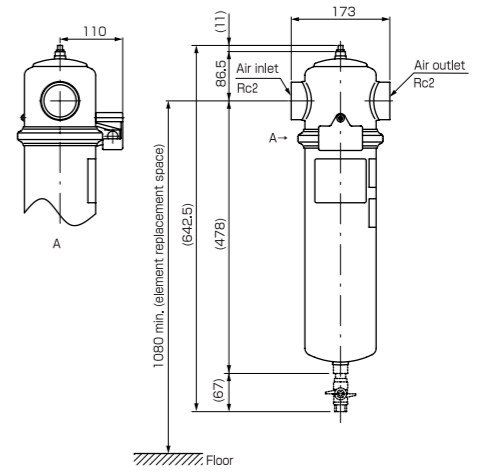

Pressure loss

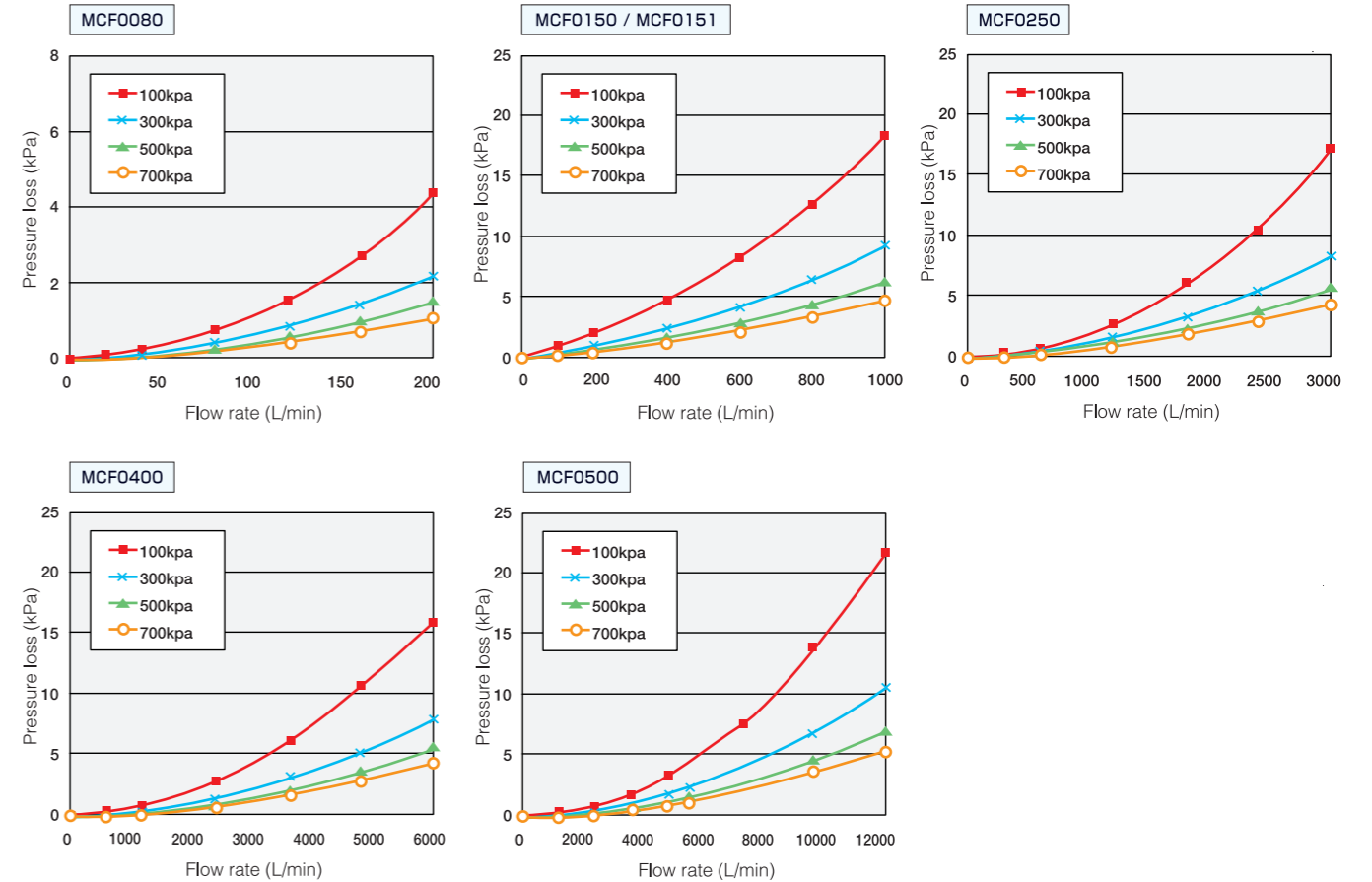

Precautions (For details, refer to the user's manual.)

Mist Separator

MFF25S Series

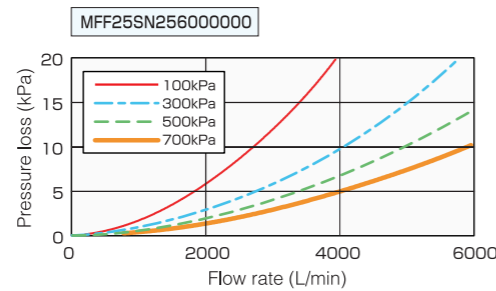
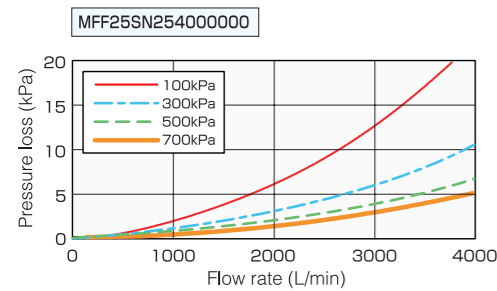
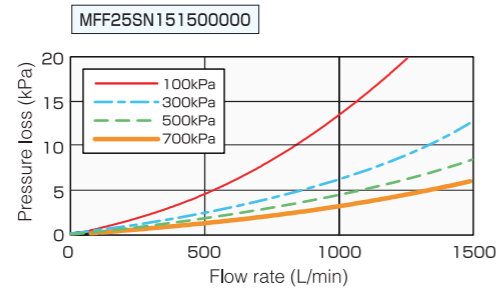
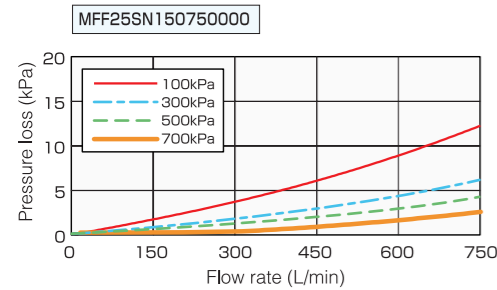
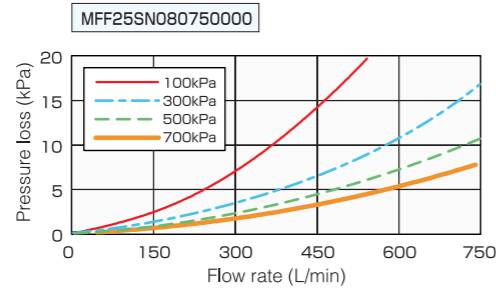
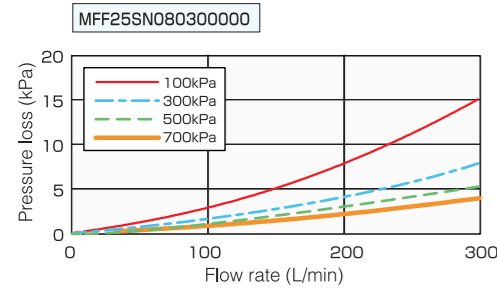

MFF25L Series

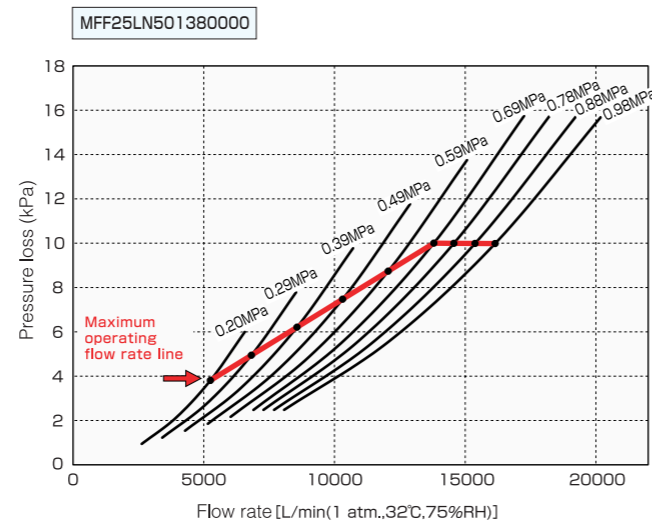
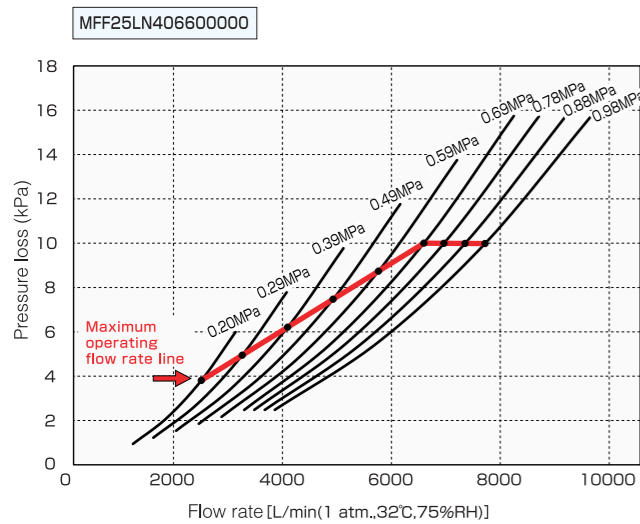

Handling precautions Do not apply more than maximum operating pressure to the air inlet.

Precautions for use

- Do not use for gases other than air and nitrogen. Doing so might have serious consequences, such as fire or explosion.
- Do not use in excess of the operating pressure range. Do not apply a pressure greater than the pressure resistance. Doing so might result in measurement error or damage to this device.
- Application of more than 10 times the full-scale flow rate might result in measurement error or damage to this device.
- Position the display, which can be rotated up to 270°, in an easy-to-see direction, taking into account the location of the cable and the location of the display.
- When changing the output settings, stop the control system equipment first to avoid unexpected operational errors.
- Since this device does not have built-in protection against lightning, be sure to provide lightning surge protection for the equipment.
- If there is equipment or a device (e.g., electromagnetic lift, high-frequency induction furnace) generating surges nearby, take countermeasures at the surge-generating equipment, and do not run its wiring together with that of the MCF.
- Be sure to use within the specified flow rate range. To prevent flow at an excessive rate, use instrumentation with appropriate supply pressure management and install a throttling valve. If the flow rate exceeds 10 times the upper limit of the range, the displayed and output values might be lower than the actual flow rate.

Precautions for installation and piping

- Handle this precision device with much care. Dropping it or subjecting it to impact may result in damage.
- To attach this device to a pipe, fix the MCF in place, and then rotate the connecting pipe to the tightening torque specified in the table below.

Model No.	Pipe size	Tightening torque (N·m)
MCF0080	1/8B	12 to 14
MCF0150 MCF0151	3/8B	31 to 33
MCF0250	1B	36 to 38
MCF0400	1 1/2B	59 to 61
MCF0500	2B	74 to 76

- Prevent foreign matter from entering the device. If rust, water droplets, oil mist, or dust in the piping enters the device, measurement error or damage to the device might result. Before installation, thoroughly flush the upstream and downstream piping and check that no foreign matter remains. If there is a possibility of foreign matter entering the device, install an upstream filter, strainer or mist trap capable of eliminating foreign matter 1 μm or greater in diameter, and be sure to periodically inspect and replace the filter.
- Use an appropriate amount of sealant on the pipe threads, but do not coat the top two threads. If too much sealant is applied, it might enter the pipe, causing measurement error or damage to this device.
- This device can be mounted in any direction. However, if it is mounted on a horizontal pipe with the display in front (in a vertical plane), a measurement error might occur, depending upon the application pressure (see specifications). Also, if the device is mounted on a horizontal pipe with the display facing downward, rust, water droplets, oil mist, or dust in the piping may stick to the sensor, resulting in measurement error or damage.
- Do not install near the output of a compressor or in a similar location affected by pulsing flow or drift. Do not install near a check valve that is hunting. Measurement error might result.

Accuracy and straight pipe length

<Connection with different size piping, valve or filter>

- Install straight pipes as needed with the lengths given in the table below. If a device that is not listed in the table is installed either upstream or downstream, contact Yamatake for the length of the straight pipe section. If reverse flow is also expected, it is necessary to have the same length of straight pipe downstream as upstream.

Pipe or connected device	Location in relation to the MCF	Straight pipe section for this device	
		For accuracy within product specification range (±3% FS)	For accuracy of ±5% FS
MFF25S mist separator for MCF0080/0150/0151/0250 *2	Upstream	10D	(Not required)
MFF25L mist separator for MCF0400/0500 *2	Upstream	20D	(Not required)
Pipe one size larger in dia. (connected with reducer)	Upstream	5D	(Not required)
MCF0080 3/8B → 1/4B	Downstream	(Not required)	(Not required)
MCF0150/0151 3/4B → 1/2B	Downstream	(Not required)	(Not required)
MCF0250 1 1/4B → 1B	Downstream	(Not required)	(Not required)
MCF0400 2B → 1 1/2B	Downstream	(Not required)	(Not required)
Pipe one size larger in dia. (connected with enlarging pipe)	Upstream	10D	5D
MCF0500 2 1/2B → 2B	Downstream	5D	5D
Pipe more than one size smaller in dia. (connected with enlarging pipe)	Upstream	20D	5D
MCF0080 1/8B → 1/4B	Downstream	(Not required)	(Not required)
MCF0150 / 0151 3/8B → 1/2B	Downstream	(Not required)	(Not required)
MCF0250 3/4B → 1B	Downstream	(Not required)	(Not required)
MCF0400 1 1/4B → 1 1/2B	Downstream	(Not required)	(Not required)

Notes: *1. Do not connect a carbon steel pipe for pressure service (JIS G3454) or stainless steel pipe (JIS G3459) that is larger than schedule 40. Doing so might cause a deterioration of accuracy. (If the pipe schedule number is larger, the inner pipe diameter is smaller, resulting in reduced accuracy.) *2. The straight pipe section lengths given in the right-hand columns above are for connection of a filter the same size (internal diameter) as the MCF.

Pipe or connected device	Location in relation to the MCF	Straight pipe section for this device	
		For accuracy within product specification range (±3% FS)	For accuracy of ±5% FS
Pipe more than one size smaller in dia. (connected with enlarging pipe)	Upstream	25D	10D
MCF0500 1 1/2B → 2B	Downstream	5D	5D
Single elbow	Upstream	10D	(Not required)
	Downstream	(Not required)	(Not required)
Double elbow	Upstream	10D	10D
	Downstream	(Not required)	(Not required)
Ball valve (full-bore type full open)	Upstream	(Not required)	(Not required)
	Downstream	(Not required)	(Not required)
Regulator for MCF0080	Upstream	200D	(Not required)
	Downstream	10D	(Not required)
Regulator for MCF0150/0151/0250/0400/0500	Upstream	30D	(Not required)
	Downstream	5D	(Not required)
Air filter	Upstream	25D	(Not required)

Precautions for electric wiring

- Supply electrical power within the specified range.
- Be sure to check that the wiring is correct before turning the power ON. Incorrect wiring can cause damage or malfunction. Do not wire while the power is ON.
- Do not rotate the connector after it is inserted into the device. If it is rotated, the internal wiring might be twisted and damaged.
- Run the wiring for this device separately from power or high voltage lines (use a separate electrical conduit).