

**azbil**



**Air Flowmeter**

Model: **MCF**

*A superb way to save energy when using compressed air or nitrogen.*

CE



# Features of the MCF air flowmeter



A dedicated air/nitrogen mass flowmeter, indispensable for cutting compressor energy use.

Practical measurement range of 50:1 and extended range function providing up to 2 times the standard range are useful for detecting air leakage

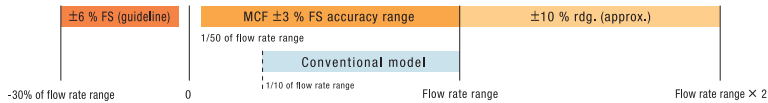

### Reverse flow detection function

Useful for loop piping. Reverse flow detection and forward-reverse flow integration functions are provided.

\*Reverse flow measurement range is up to 30% of forward flow rate measurement range.

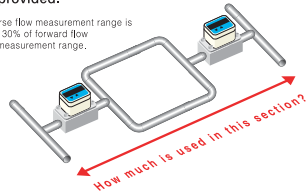

### Model lineup meets a variety of application requirements

For ease of use and ease of selection, models in a broad range from small to large are available.



Pipe size: 8/15/25/40/50A  
Range: 200/500/3000/6000/12000 L/min

### Easy maintenance without removal from the piping

The measurement unit can be dismantled and replaced for easy maintenance at the application site without disconnecting the pipes.

(Pipe sizes 25/40/50A only)



### Use a single MCF for flow in various directions

The display unit can rotate more than 90° counterclockwise and more than 180° clockwise.

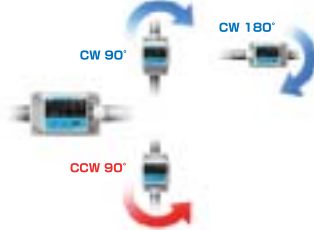

### The MCF is a mass flowmeter.

Thermal mass flow measurement using Yamatake's Micro Flow ( $\mu$ F) sensor ensures correct measurement even if gas temperature or pressure changes.

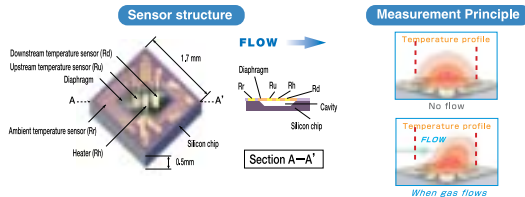

## Application examples

### Detecting air leakage



Substantial reduction of air leakage by determining the leakage quantity — generally said to be around 30% — and repairing the leaks.

#### Leakage check method

- 1 Read the instantaneous flow rate from the flowmeter.
- 2 Plot the instantaneous flow rate using a PC.



### Cost management for production line or whole department



Knowing the total flow quantity and cost for an area, and budgeting by area, is sure to increase cost consciousness and enable measurement of cost reduction efforts.

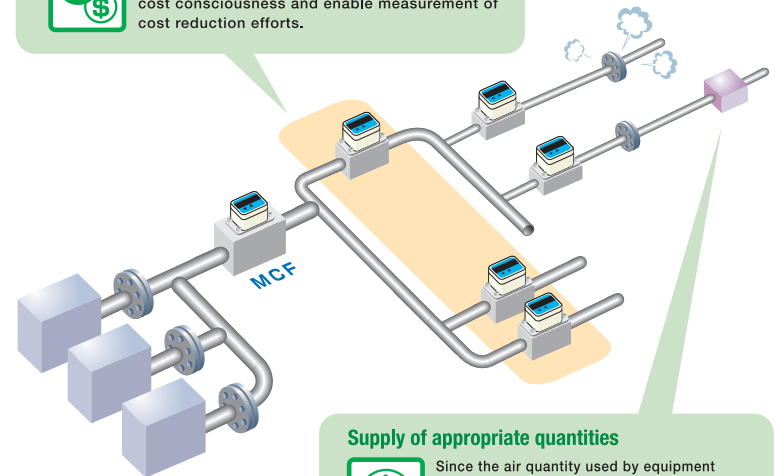

### Supply of appropriate quantities



Since the air quantity used by equipment can be checked to know if it is appropriate, waste can be reduced by restricting the air supply to an appropriate quantity.

Specifications

Model No.	MCF008	MCF015	MCF025	MCF040	MCF050
Gas types	Air/nitrogen. (Note that gas must be dry, without corrosive components such as chlorine, sulfur and acid. It must also be clean, without dust or oil mist.)				
Flow rate range [L/min(normal)] *1	0 to 200	0 to 500	0 to 3000	0 to 6000	0 to 12000
Reverse flow range [L/min(normal)] *2	-60	-150	-900	-1800	-3600
Extended range [L/min(normal)] *3	400	1000	6000	12000	24000
Accuracy guaranteed flow rate range [L/min(normal)] *4	4 to 200	10 to 500	60 to 3000	120 to 6000	240 to 12000
Measurement accuracy	± 3% FS				
Smallest detectable flow rate [L/min(normal)]	2	5	30	60	120
Display resolution [L/min(normal)]	1	1	5	10	10
Temperature	-10 to +60 °C (without condensation)				
Storage temperature	-20 to +70 °C (without condensation)				
Humidity	0 to 90 % RH (without condensation)				
Pipe size	8A(1/2B)Rc	15A(1/2B)Rc	25A(1B)Rc	40A(1 1/2B)Rc	50A(2B)Rc
Body material	Aluminum alloy, with alumite treatment on the surface				
Case material	Denatured PPO				
Operating pressure range	-0.07 to +1.0 MPa				
Pressure resistance	1.5 MPa				
Mounting orientation	·Horizontal (flow: left → right, right → left) ·Vertical (flow: up → down, down → up)				
Rated voltage	24 Vdc, 120 mA max.				
Sampling cycle/ response time	50 ms to 1.5 s max. (time for 95 % of response to 0 → 100 % FS step input)				
Output signal (instantaneous flow rate)	4 to 20 mA, allowable load resistance 300 Ω max.				
Event output	One open collector output (rating 30 Vdc, 50 mA), with output type selectable from event function.				
Event function	Selectable from pulse output for integration *5, instantaneous flow rate high/low limit alarm, integration count up/down, or alarm output.				
Electrical connection	PA5 Series VA connector (4 pins)				
Display	7-segment, 5-digit display changeable between instantaneous flow rate, integrated (cumulative) flow, and cost.				
Protective structure	IP65. (Rating is based on JIS C 0920 and IEC529. For purposes of installation indoors, device is waterproof and dustproof.)				
Standards compliance	CE marked : EN61326-2-3 : 2006				
Mass	400 g	400 g	500 g	700 g	1100 g

Notes: \*1. The unit L/min (normal) refers to the volumetric flow rate adjusted for 0 °C, 101.325 kPa. \*2. Flow is displayed as a negative value even if the setting is not changed. \*3. Indication value and integrated pulse output can be displayed and output even if the setting is not changed, but 4~20 mA output requires a change of the span setting. \*4. The guaranteed accuracy range figures are ± 3% FS. \*5. Integrated pulse output specifications (selectable by settings)  
 \* Pulse width: 30 ms, 250 ms, 500 ms  
 \* Pulse weight:

Model No.	Pulse weight (L/pulse)
MCF008	10, 100, 1000
MCF015	10, 100, 1000
MCF025	10, 100, 1000
MCF040	100, 1000, 10000
MCF050	100, 1000, 10000

Selection guide Ex.: MCF0080ARND010000

Basic model No.	Pipe size	Model	Material	Connection	Gas type	Power/output	Option	Connection device	Option	Design code	Description	
MCF	008										Air management flowmeter	
											8A(1/2B)	
											15A(1/2B)	
											25A(1B)	
											40A(1 1/2B)	
	015											Flowmeter
												Body: aluminum alloy
												Rc thread
												Air/nitrogen
												24 Vdc / 4~20 mA output / one open collector
												(None)
												(None)
(None)												
025											Inspection certificate provided	
											Product version	

PA5 Series cable with VA connector

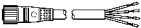
Shape	Power	Cable properties	Cable length	Model No.	Lead color
	DC	Oil resistant, bend-tolerant UL2464 Flame-resistant cable EN-compliant.	2 m	PA5-4ISX2MK-E	1: Brown, 2: White, 3: Blue, 4: Black.
			5 m	PA5-4ISX5MK-E	1: Brown, 2: White, 3: Blue, 4: Black.

Note: Types other than the above are available. Please contact Yamatake Corporation.

External dimensions (Unit: mm)

MCF008

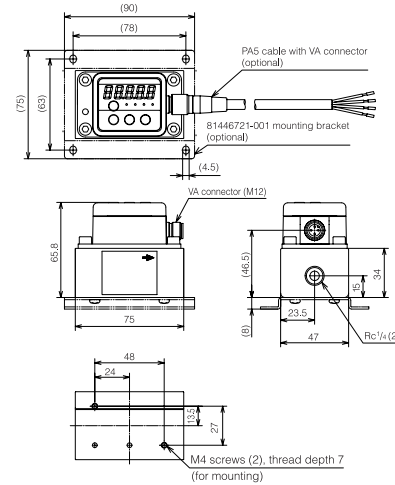

MCF015

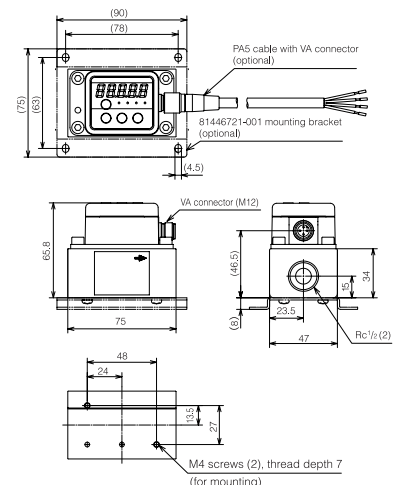

MCF025

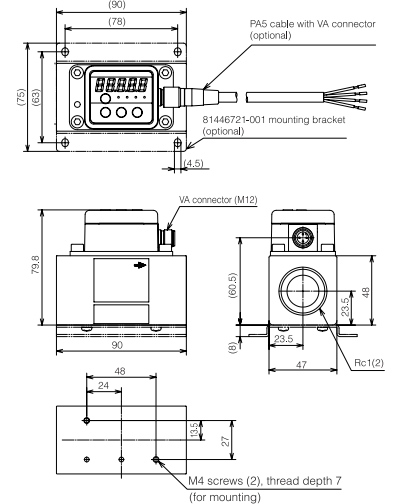

MCF040

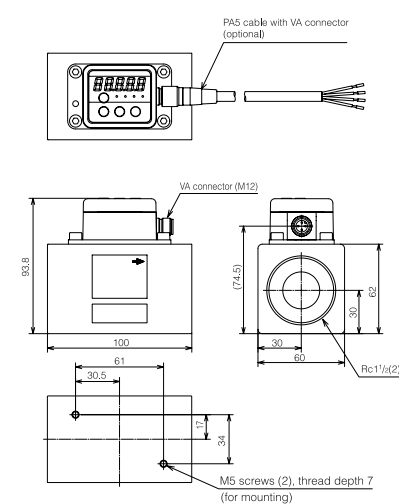

External dimensions (Unit: mm)

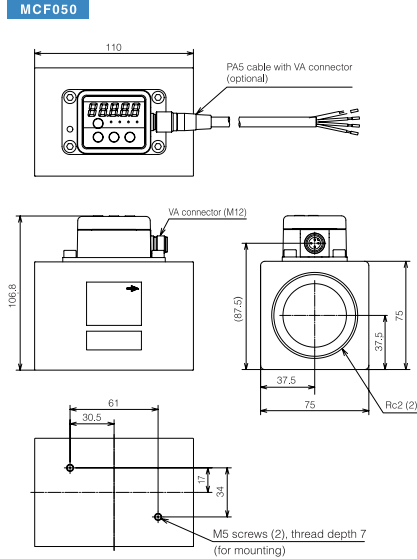

Wiring pin assignment

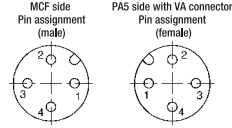

- Connector pin No., PA5 lead color, and signal
- 1: Brown ·····24 Vdc
  - 2: White ·····4 to 20 mA output
  - 3: Blue ····· COM
  - 4: Black ·····Event output

Wiring example

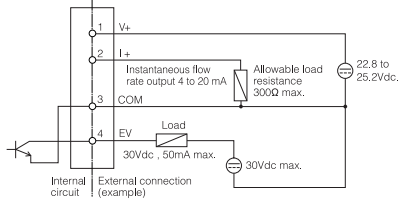

Pressure loss

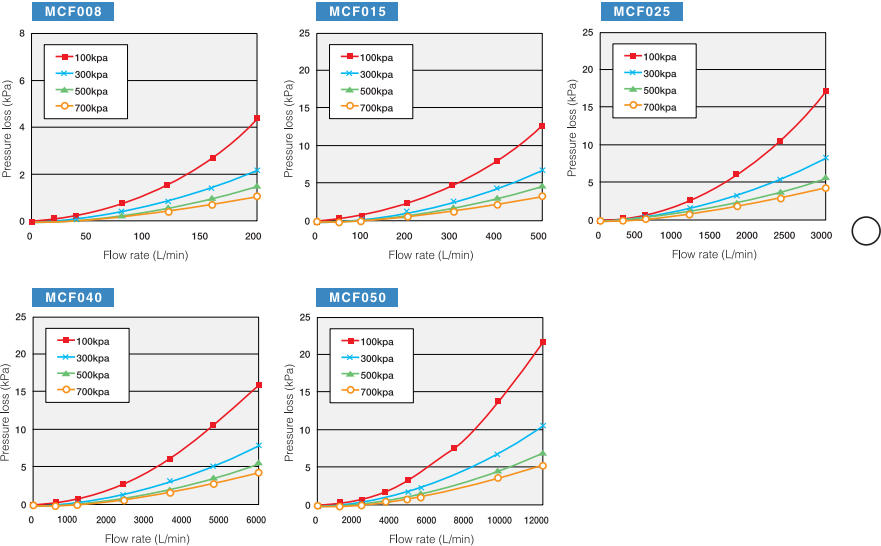

Precautions (For details, refer to the user's manual.)

Precautions for use

- Do not use for gases other than air and nitrogen. Doing so might have serious consequences, such as fire or explosion.
- Do not use in excess of the operating pressure range. Do not apply a pressure greater than the pressure resistance. Doing so might result in measurement error or damage to this device.
- Application of more than 10 times the full-scale flow rate might result in measurement error or damage to this device.
- Position the display, which can be rotated up to 270°, in an easy-to-see direction, taking into account the location of the cable and the location of the display.
- When changing the output settings, stop the control system equipment first to avoid unexpected operational errors.
- Since this device does not have built-in protection against lightning, be sure to provide lightning surge protection for the equipment.
- If there is equipment or a device (e.g., electromagnetic lift, high-frequency induction furnace) generating surges nearby, take countermeasures at the surge-generating equipment, and do not run its wiring together with that of the MCF.
- Be sure to use within the specified flow rate range. To prevent flow at an excessive rate, use instrumentation with appropriate supply pressure management and install a throttling valve. If the flow rate exceeds 10 times the upper limit of the range, the displayed and output values might be lower than the actual flow rate.

Precautions for installation and piping

- Handle this precision device with much care. Dropping it or subjecting it to impact may result in damage.
- To attach this device to a pipe, fix the MCF in place, and then rotate the connecting pipe to the tightening torque specified in the table below.

Model No.	Pipe size	Tightening torque (N·m)
MCF008	1/2B	12 to 14
MCF015	1/2B	31 to 33
MCF025	1B	36 to 38
MCF040	1 1/2B	59 to 61
MCF050	2B	74 to 76

- Prevent foreign matter from entering the device. If rust, water droplets, oil mist, or dust in the piping enters the device, measurement error or damage to the device might result. Before installation, thoroughly flush the upstream and downstream piping and check that no foreign matter remains. If there is a possibility of foreign matter entering the device, install an upstream filter, strainer or mist trap capable of eliminating foreign matter 1 μm or greater in diameter, and be sure to periodically inspect and replace the filter.
- Use an appropriate amount of sealant on the pipe threads, but do not coat the top two threads. If too much sealant is applied, it might enter the pipe, causing measurement error or damage to this device.
- This device can be mounted in any direction. However, if it is mounted on a horizontal pipe with the display in front (in a vertical plane), a measurement error might occur, depending upon the application pressure (see specifications). Also, if the device is mounted on a horizontal pipe with the display facing downward, rust, water droplets, oil mist, or dust in the piping may stick to the sensor, resulting in measurement error or damage.
- Do not install near the output of a compressor or in a similar location affected by pulsing flow or drift. Do not install near a check valve that is hunting. Measurement error might result.

Straight pipe length

When connecting to a valve or filter, be sure to have the straight pipe length shown in the table below. When connecting to something not listed in the table below, use a straight pipe length of 15D on the upstream side of this device and 5D on the downstream side.

Pipe or connected device	Location in relation to the MCF	Straight pipe section for this device		Pipe or connected device	Location in relation to the MCF	Straight pipe section for this device	
		For accuracy within product specification range (±3 % FS)	For accuracy of ±5 % FS			For accuracy within product specification range (±3 % FS)	For accuracy of ±5 % FS
Mist filter - For MCF008/015/025	Upstream	10D	(Not required)	Ball valve	Upstream	20D	10D
Mist filter - For MCF040/050	Upstream	20D	(Not required)	Regulator - For MCF008	Upstream	200D	(Not required)
Elbow	Upstream	10D	(Not required)	Regulator - For MCF015/025/040/050	Downstream	10D	(Not required)
	Downstream	(Not required)	(Not required)	Regulator	Upstream	30D	(Not required)
Pipe one size larger in dia. (connection using a bushing or reducer)	Upstream	5D	(Not required)	Air filter	Downstream	5D	(Not required)
Pipe one size smaller in dia. (connection using a bushing or increaser)	Upstream	15D	(Not required)	Air piping tube joint Dia. 8 tube size - For MCF008	Upstream	15D	5D
				Air piping tube joint Dia. 12 tube size - For MCF008	Downstream	(Not required)	(Not required)
	Downstream	(Not required)	(Not required)	Air piping tube joint Dia. 12 tube size - For MCF008	Upstream	5D	(Not required)
				Air piping tube joint Dia. 12 or 16 tube size - For MCF015 <sup>1</sup>	Downstream	(Not required)	(Not required)
Air piping tube joint Dia. 12 or 16 tube size - For MCF015 <sup>2</sup>	Upstream	10D	(Not required)	Air piping tube joint Dia. 12 or 16 tube size - For MCF015 <sup>2</sup>	Upstream	10D	5D
				Air piping tube joint Dia. 12 or 16 tube size - For MCF025 <sup>2</sup>	Downstream	(Not required)	(Not required)
	Downstream	(Not required)	(Not required)	Air piping tube joint Dia. 12 or 16 tube size - For MCF015 <sup>2</sup>	Upstream	10D	8D
				Air piping tube joint Dia. 12 or 16 tube size - For MCF025 <sup>2</sup>	Downstream	5D	5D

Notes: <sup>1</sup> When connecting to a pipe two or more sizes larger or smaller in diameter, use the specified straight length + another 15D on the upstream side, and the specified straight length + another 5D on the downstream side. The specified straight length is the length required when connecting to a pipe one size or more larger or smaller in diameter.  
<sup>2</sup> Do not connect to a pipe smaller than the specified size without using a straight pipe section. Even if the gas is flowing in a forward direction in the main flow path, it might flow in the reverse direction within the measurement device, resulting in a negative displayed value. (Alien leak) a flow rate considerably lower than the actual one might be displayed.

Precautions for electric wiring

- Supply electrical power within the specified range.
- Be sure to check that the wiring is correct before turning the power ON. Incorrect wiring can cause damage or malfunction. Do not wire while the power is ON.
- Do not rotate the connector after it is inserted into the device. If it is rotated, the internal wiring might be twisted and damaged.
- Run the wiring for this device separately from power or high voltage lines (use a separate electrical conduit).



Air Flowmeter Model: MCF

[www.azbil.com](http://www.azbil.com)

**⚠ RESTRICTIONS ON USE**

This product has been designed, developed and manufactured for general-purpose application in machinery and equipment. Accordingly, when used in applications outlined below, special care should be taken to implement a fail-safe and/or redundant design concept as well as a periodic maintenance program.

- Safety devices for plant worker protection
- Start/stop control devices for transportation and material handling machines
- Aeronautical/aerospace machines
- Control devices for nuclear reactors

Never use this product in applications where human safety may be put at risk.

**azbil**

*Specifications are subject to change without notice.*

**Yamatake Corporation**  
**Advanced Automation Company**

1-12-2 Kawana, Fujisawa  
Kanagawa 251-8522 Japan  
URL: <http://www.azbil.com>

Printed in Japan (ST)  
1st Edition: Issued Feb. 2008

*No part of this publication may be reproduced or duplicated without the prior written permission of Yamatake Corporation.*