



CMQ-V Series Digital Mass Flow Controller

User's Manual Communications



Thank you for purchasing the CMQ-V Series Digital Mass Flow Controller.

This manual contains information for ensuring correct use of the CMQ-V Series communication functions.

This manual should be read by those who design and maintain devices that use the CMQ-V Series communication functions. Be sure to keep this manual nearby for handy reference.

Yamatake Corporation

RESTRICTIONS ON USE

This product has been designed, developed and manufactured for general-purpose application in machinery and equipment.

When using this product in application requiring particular safety, special care should be taken to implement a fail-safe and/or redundant design concept as well as a periodic maintenance program.

Do not use this product in applications outlined below requiring particular safety.

- Safety devices for plant worker protection
- Start/stop control devices for transportation and material handling machines
- Aeronautical/aerospace machines
- Control devices for nuclear reactors

Never use this product in applications where human safety may be put at risk.

IMPORTANT

If it is necessary to change the parameters of the CMQ-V Series frequently by communication, write data at addresses of RAM. The guaranteed data write count at the EEPROM addresses is limited to 100,000 times.

Note that the data in RAM is cleared, and the data in EEPROM is copied on RAM if the power supply to the CMQ-V Series interrupted.

NOTICE

Be sure that the user receives this manual before the product is used.

Copying or duplicating this user's manual in part or in whole is forbidden. The information and specifications in this manual are subject to change without notice.

Considerable effort has been made to ensure that this manual is free from inaccuracies and omissions. If you should find an error or omission, please contact Yamatake Corporation.

In no event is Yamatake Corporation liable to anyone for any indirect, special or consequential damages as a result of using this product.

©2007 Yamatake Corporation ALL RIGHTS RESERVED

Micro Flow™, μ F™, CMQ™ are trademarks of Yamatake Corporation.

SAFETY PRECAUTIONS

■ About Icons

Safety precautions are for ensuring safe and correct use of this product, and for preventing injury to the operator and other people or damage to property. You must observe these safety precautions. The safety precautions described in this manual are indicated by various icons.

The following describes the icons and their meanings. Be sure to read and understand the following descriptions before reading this manual.



CAUTION

Cautions are indicated when mishandling this product might result in minor injury to the user, or only physical damage to this product.

■ Examples

	<p>Triangles warn the user of a possible danger that may be caused by wrongful operation or misuse of this product.</p> <p>These icons graphically represent the actual danger. (The example on the left warns the user of the danger of electrical shock.)</p>
	<p>White circles with a diagonal bar notify the user that specific actions are prohibited to prevent possible danger.</p> <p>These icons graphically represent the actual prohibited action. (The example on the left notifies the user that disassembly is prohibited.)</p>
	<p>Black filled-in circles instruct the user to carry out a specific obligatory action to prevent possible danger.</p> <p>These icons graphically represent the actual action to be carried out. (The example on the left instructs the user to remove the plug from the outlet.)</p>

CAUTION



Use the CMQ-V Series within the operating ranges recommended in the specifications of user's manual, CP-SP-1204E and CP-SP-1205E (temperature, humidity, voltage, vibration, shock, mounting direction, atmosphere, etc.). Failure to do so might cause malfunction.



Be sure to turn the power off before connecting the controller. Failure to do so might cause malfunction.



Wire this controller in compliance with the predetermined standards. Also wire the controller with specified cables and recognized installation methods.
Failure to do so might cause malfunction.



Make sure that wire scraps, chips or water do not enter inside the case of the controller. Failure to heed this caution may lead to malfunction.



If there is a risk of a power surge caused by lightning, use Yamatake Corporation's SurgeNon to prevent possible fire or equipment failure.



Be sure to check that the wiring is correct before turning the power on. Incorrect wiring could cause damage or malfunction.



Do not disassemble the controller. Doing so might cause malfunction.

The Role of This Manual

Four manuals have been prepared for the CMQ-V Series. Read the manual according to your specific requirements. The below lists all the manuals that accompany the CMQ-V Series and gives a brief outline of the manual. If you do not have the required manual, contact Yamatake Corporation or your dealer.

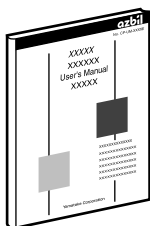

CMQ-V Series Digital Mass Flow Controller

Manual No. CP-SP-1204E

First-time users of the CMQ-V Series, and those in charge of maintenance or hardware design for incorporating a CMQ-V Series controller in instrumentation should read this manual.

This manual outlines the product, tells how to install, wire, and incorporate the product into instrumentation, and describes its operation, inspection and maintenance, troubleshooting, and hardware specifications.

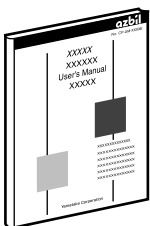

CMQ-V Series Digital Mass Flow Controller (for Hydrogen and Helium Gases)

Manual No. CP-SP-1205E

First-time users of the CMQ-V Series (for hydrogen and helium gases), and those in charge of maintenance or hardware design for incorporating a CMQ-V Series controller (For hydrogen and helium gases) in instrumentation should read this manual.

This manual outlines the product, tells how to install, wire, and incorporate the product into instrumentation, and describes its operation, inspection and maintenance, troubleshooting, and hardware specifications.

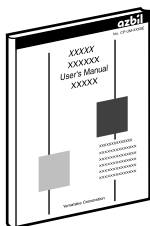

Digital Mass Flow Controller CMQ-V Series: Communications

Manual No. CP-SP-1197E

This manual.

Those using the communications functions of the CMQ-V series should read this manual.

This manual describes an outline of communications, wiring, communications procedures, CMQ-V series communications data, troubleshooting, and communications specifications.

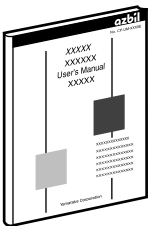

MLP100 Loader Package for CMQ-V Series Digital Mass Flow Controller

Manual No. CP-SP-1216E

This manual is supplied with the MLP100 Loader Package.

The manual describes the software used to make various settings for CMQ-V Series using a personal computer. Personnel in charge of design or setting of a system using CMQ-V Series must thoroughly read this manual. The manual describes installation of the software into a personal computer, operation of the personal computer, various functions, and setup procedures.

Organization of This User's Manual

This manual is organized as follows:

Chapter 1. OUTLINE

This chapter briefly describes communication functions of the CMQ-V Series.

Chapter 2. WIRING

This chapter describes RS-485 wiring methods to make a communication link between the CMQ-V Series and other instruments.

Chapter 3. SETTING

This chapter describes CMQ-V Series communication settings.

Chapter 4. COMMUNICATION PROCEDURE

This chapter describes communication procedures, message configuration, data read/write and signal timing operations.

Chapter 5. COMMUNICATION DATA TABLE

This chapter provides various data address tables for communications on the CMQ-V Series.

Chapter 6. COMMUNICATION PROGRAM FOR MASTER STATION

This chapter gives precautions for programming and an example of a communication program for the CMQ-V Series.

Chapter 7. TROUBLESHOOTING

This chapter describes checkpoints to diagnose failures in CMQ-V Series communications.

Chapter 8. SPECIFICATIONS

This chapter lists communication specifications for the CMQ-V Series.

APPENDIX

The appendix provides code tables.

Conventions Used in This Manual

The following conventions are used in this manual:



Handling Precautions

: Handling Precautions indicate items that the user should pay attention to when handling the CMQ-V Series.



Note

: Notes indicate useful information that the user might benefit by knowing.

(1), (2), (3)

: The numbers with the parenthesis indicate steps in a sequence or indicate corresponding parts in an explanation.

DISP key

: This indicates a key on the setup display.

Contents

SAFETY PRECAUTIONS

The Role of This Manual

Organization of This User's Manual

Conventions Used in This Manual

Chapter 1. OUTLINE

- Features 1

Chapter 2. WIRING

- 2-1 RS-485 Connection 3
- 2-2 Connector Pin Layout of the CMQ-V Series 4

Chapter 3. SETTING

- Setting method of communication functions 6
- Setting items of communication functions 6

Chapter 4. COMMUNICATION PROCEDURE

- 4-1 Outline of Communication 7
 - Communication procedures 7
- 4-2 Message Structure 8
 - Message structure 8
 - Data link layer 8
 - Application layer 10
- 4-3 Description of Commands 11
 - Continuous data read command (RS command) 11
 - Continuous data write command (WS command) 12
 - Continuous data read command (RD command) 13
 - Continuous data write command (WD command) 14
- 4-4 Termination Code Table 15
 - Normal and warning termination 15
 - Error termination 15
- 4-5 Timing Specifications 16
 - Timing specifications for instruction and response message 16
 - RS-485 driver control timing specifications 16
 - Other precautions 17

Chapter 5. COMMUNICATION DATA TABLE

5-1	Basic Communication Data Processing	18
■	Communication data types and formats	18
■	Communication data storage memory	18
■	Data address	19
■	Data read / write count	19
■	Data unit and decimal point position	19
5-2	Communication Data Table	20
■	Device related data	20
■	Operating status related data	21
■	Flow set value	23
■	Totalized flow related data	23
■	Function setup related data	24
■	Parameter setup related data	30

Chapter 6. COMMUNICATION PROGRAM FOR MASTER STATION

6-1	Precautions for Programming	32
6-2	Examples of Communication Program	33
■	Before executing the program	33
■	Executing the program	33
■	Data read/write sample program	34

Chapter 7. TROUBLESHOOTING

■	Check items in case communication is disabled	39
---	---	----

Chapter 8. SPECIFICATIONS

■	RS-485 specifications	40
---	-----------------------------	----

APPENDIX

■	Code table	41
■	Connection with CMC10L	42

Chapter 1. OUTLINE

If the optional model is provided with the RS-485 communications function, communication with a PC, PLC or other host devices are available using a user-configured program.

The communication protocol can be selected from the Controller Peripheral Link (CPL) communications (Yamatake's host communication protocol). This chapter describes the CPL communications.

■ Features

The features of the CMQ-V's communications function are as follows:

- Up to 31 units can be connected to a single master station as a host device.
- When the communication specifications of the host device conform to the RS-232C interface, the communication converter CMC10L (sold separately) is required. The CMC10L allows the conversion between RS-232C and RS-485.
- Almost all of the device parameters can be communicated.

For details on communication parameters, refer to;

☞ Chapter 5, COMMUNICATION DATA TABLE.

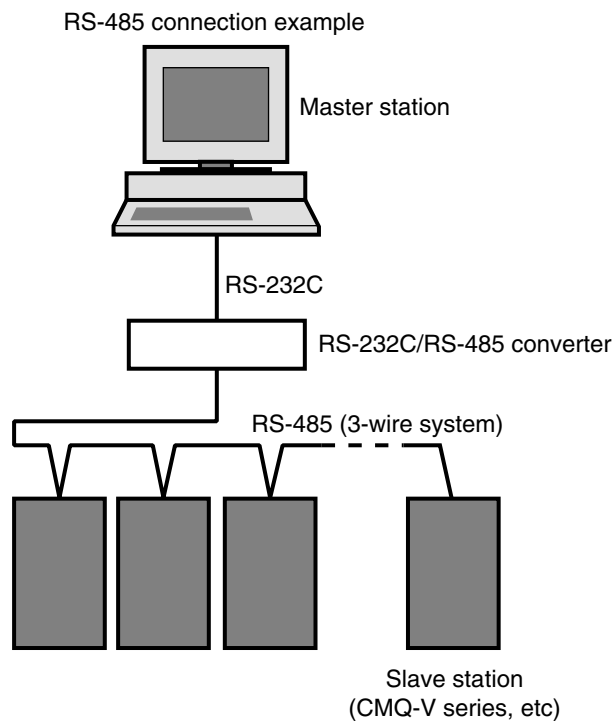

Connection between master station and slave station

Chapter 2. WIRING

CAUTION



Use the CMQ-V Series within the operating ranges recommended in the specifications of user's manual, CP-SP-1204E and CP-SP-1205E (temperature, humidity, voltage, vibration, shock, mounting direction, atmosphere, etc.). Failure to do so might cause malfunction.



Be sure to turn the power off before connecting the controller. Failure to do so might cause malfunction.



Wire this controller in compliance with the predetermined standards. Also wire the controller with specified cables and recognized installation methods. Failure to do so might cause malfunction.



Make sure that wire scraps, chips or water do not enter inside the case of the controller. Failure to heed this caution may lead to malfunction.



If there is a risk of a power surge caused by lightning, use Yamatake Corporation's SurgeNon to prevent possible fire or equipment failure.



Be sure to check that the wiring is correct before turning the power on. Incorrect wiring could cause damage or malfunction.



Do not disassemble the controller. Doing so might cause malfunction.

Handling Precautions

- Wiring way except the RS-485 communications wiring, refer to; CMQ-V series Digital Mass Flow Controller user's manual No.CP-SP-1204E or CMQ-V Series Digital Mass Flow Controller (for Hydrogen and Helium Gases) user's manual No.CP-SP-1205E.

2 - 1 RS-485 Connection

An example of connection methods in such a case is shown below.

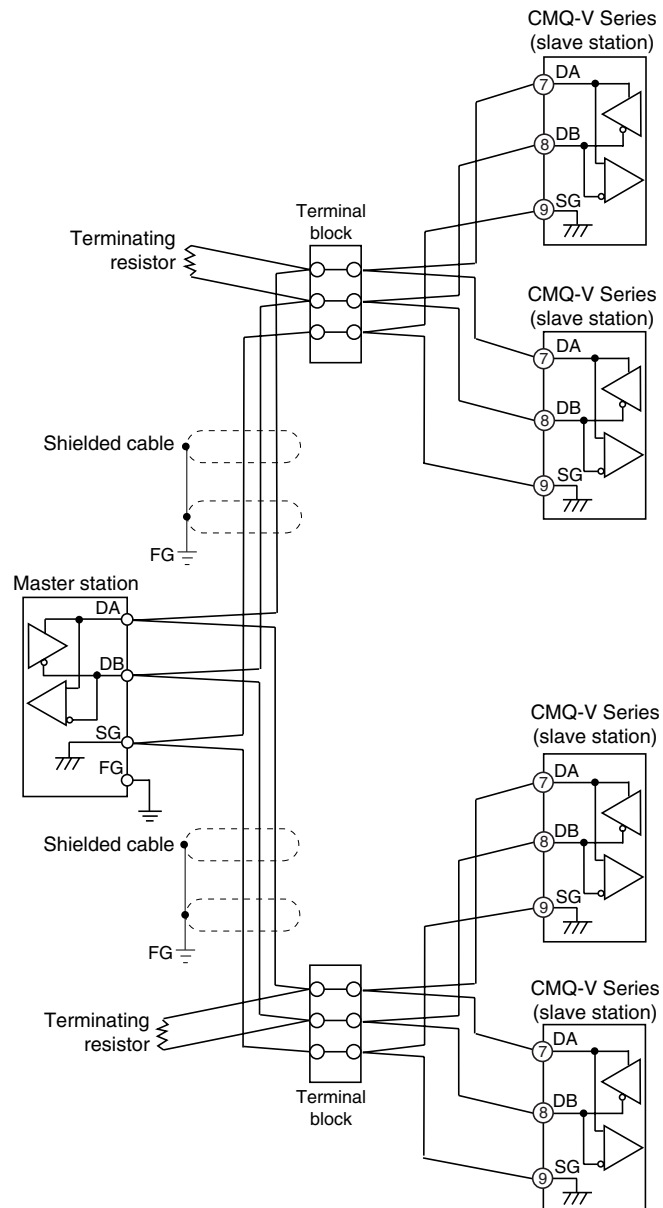

- Connect terminating resistors of $150\Omega \pm 5\%$, $1/2W$ min. at each end of the transmission line.
- Terminal block is required for the CMQ-V series because of the connector type connection.
- The cable to the terminal block from the CMQ-V series must be as short as possible.
- The FG grounding must not be made at the both shielded wire ends but only at one location.
- Yamatake's CMC10L001A000 can be used as a converter of the host station.

! Handling Precautions

Be sure to connect SG terminals each other. Failure to do so might cause unstable communications.

2 - 2 Connector Pin Layout of the CMQ-V Series

The following shows the connector pin layout of the CMQ-V Series with the communication functions:

● **Connector pin layout**

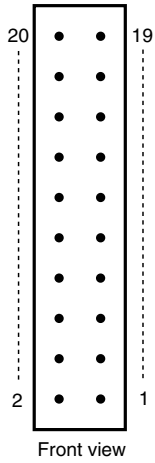

Mounted connector part number: HIF3BA-20PA-2.54DS
 Manufacturer: Hirose Electric Co. Ltd.

● **Mating connector table (All connectors are made by Hirose Electric Co. Ltd.)**

Connector type	Mating connector part No.	Mating contact part No.	Recommended wire
Contact crimp type	HIF3BA-20D-2.54C	HIF3-2226SCC	AWG#22 to #26 (single wire allowed)
Forced pressure type	HIF3BA-20D-2.54R	Not required	AWG#28 (Flat ribbon cable only)

● Connector signal table

Pin number	Signal name	Description	Remarks
20	+5V (5mA max.)	5Vdc reference voltage output	5mA max.
19	FLOW OUT	Instantaneous flow rate (PV) voltage output/ setting flow rate (SP) output	0 to 5Vdc/ 1 to 5Vdc/ 0 to 20mAdc/ 4 to 20mAdc
18	A.GND	Analog ground	Common of analog signals
17	FLOW SP INPUT	Instantaneous flow rate setting (SP) voltage input	0 to 5Vdc/ 1 to 5Vdc/ 0 to 20mAdc/ 4 to 20mAdc
16	MODE INPUT	External 3-stage switching input	3-stage switching input of Open/ GND/ 5V
15	DI3	External contact input 3	Switching input of Open/ GND
14	DI2	External contact input 2	
13	DI1	External contact input 1	
12	EV2 OUT	Event output 2	Open collector non-insulated output
11	EV1 OUT	Event output 1	
10	ALM OUT	Alarm output	
9	SG (D.GND)	RS-485 communications SG	Same as the common of digital signal
8	DB	RS-485 communications DB	
7	DA	RS-485 communications DA	
6	SG (D.GND)	RS-485 communications SG	Same as the common of digital signal
5	TEST	For test	For test (connecting is prohibited)
4	POWER GND	Power supply ground	In order to decrease the voltage drop caused by wiring resistance, connect each two wires to the power supply in parallel.
3	POWER GND	Power supply ground	
2	POWER (24V)	Power supply +24Vdc	
1	POWER (24V)	Power supply +24Vdc	

! Handling Precautions

- Either pin No. 6 and pin No. 9 is able to connect as SG.
- For details on wiring way, see the CMQ-V Series Digital Mass Flow Controller user's manual No. CP-SP-1204E or CMQ-V Series Digital Mass Flow Controller (for Hydrogen and Helium Gases) user's manual No. CP-SP-1205E.

Chapter 3. SETTING

Setup the following to operate the communication functions of the CMQ Series:

■ Setting method of communication functions

Follow the following procedure to set the functions:

- (1) Display the instantaneous flow rate by pressing the **DISP key**.
>> “**PV**” lamp and “**L/min**” lamp (“mL/min” in MQV9200) start lighting.
- (2) Keep pressing the **▼ key** and the **ENT key** at the same time for 3 seconds or more.
>> The item No. **└-0┐** appears on the 7-segment display and mode changes to the function setup mode.
- (3) Select a desired setup item by pressing either **▲ key** or **▼ key** and then press the **ENT key**.
>> The current setting flashes on the 7-segment display.
- (4) Select a desired setting by pressing either **▲ key** or **▼ key**.
- (5) After a desired setup mode is selected, confirm it by pressing the **ENT key**.
>> At this point the setup is updated. (After about one second, the item number display is returned.)
- (6) If other setting items are desired, return to (3) for setting. If no other item is desired to be set, proceed to the item (7).
- (7) Press the **DISP key** to make the status from the function setup mode to instantaneous flow rate display.

! Handling Precautions

- If any key is not pressed for one minute after the function setup mode, the display automatically returns to the instantaneous flow rate display.
- If the **DISP key** is pressed without pressing the **ENT key** after carrying out the operation in step (4), the setting remains at the previous value without being update.

■ Setting items of communication functions

Function setup item	Item	Setup item and description	Factory setting	Remarks
└-30	Station address	0: Communications function disabled 1 to 127: Station address	0	The communications function does not work at 0. Set a different address from the slave station.
└-31	Transmission speed	0: 38400bps 1: 19200bps 2: 9600bps 3: 4800bps 4: 2400bps	1	
└-32	Data format	0: 8 bit data, even parity, 1 stop bit 1: 8 bit data, no parity, 2 stop bits	0	

Chapter 4. COMMUNICATION PROCEDURE

4 - 1 Outline of Communication

■ Communication procedures

The communication procedure is as follows:

- (1) The instruction message is sent from the host device (master station) to one unit (slave station) to communicate with.
- (2) The slave station receives the instruction message, and performs read or write processing according to the content of the message.
- (3) The slave station sends a message corresponding to the processing content as a response message.
- (4) The master station receives the response message.

4 - 2 Message Structure

■ Message structure

The following shows the message structure:

Messages are broadly classified into two layers; the data link layer and the application layer.

- Data link layer

This layer contains the basic information required for the communication such as the destination of the communication message and the check information of the message.

- Application layer

Data is read and written in this layer. The content of the layer varies according to the purpose of the message.

Messages comprise parts (1) to (9) as shown in the figure below.

The command (details sent from the master station) and the response (details returned from the slave station) are stored in the application layer.

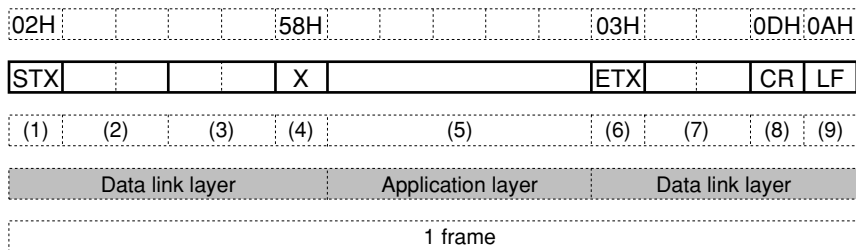

- | | |
|--|-----------------------------------|
| (1) STX (start of message) | (6) ETX (end of command/response) |
| (2) Station address | (7) Checksum |
| (3) Sub-address | (8) CR (delimiter) |
| (4) Device code | (9) LF (delimiter) |
| (5) Send message = command,
response message = response | |

■ Data link layer

- Outline

The data link layer is of a fixed length. The position of each data item and the number of its characters are already decided. Note, however, that the data positions of the data link layer from ETX onwards shift according to the number of characters in the application layer. The character length, however, remains unchanged.

- Response start conditions

- The device sends the response message only when (1) message structure, station address, sub-address, checksum and message length of a single frame in the data link layer are all correct. If even one of these is incorrect, no response messages are sent, and the device waits for new message.
- Number of word addresses accessible by a single frame

Type	Description of command	RAM area	EEPROM area
RS	Decimal format read command	1 to 10	1 to 10
WS	Decimal format write command	1 to 10	1 to 10
RD	Hexadecimal format read command	1 to 10	1 to 10
WD	Hexadecimal format write command	1 to 10	1 to 10

● List of data link layer data definitions

The following list shows the definitions for data in the data link layer:

Data name	Character code	Number of characters	Meaning of data
STX	02H	1	Start of message
Station address	0 to 7FH are expressed as hexadecimal character codes.	2	Identification of device to communicate with
Sub-address	"00" (30H, 30H)	2	No function
Device code	"X" (58H) or "x" (78H)	1	Device type
ETX	ETX (03H)	1	End position of the application layer
Checksum	00H to FFH are expressed as two-digit hexadecimal character codes.	2	Checksum of message
CR	0DH	1	End of message (1)
LF	0AH	1	End of message (2)

● Description of data items

• STX (02H)

When STX is received, the device judges this to be the start of the send message. For this reason, the device returns to the initial state whatever reception state it was in, and processing is started on the assumption that the STX, the first character, has been received. The purpose of this is to enable recovery of the device's response at the next correct message (e.g. RETRY message) from the master station in the event that noise, for example, causes an error in the sent message.

• Station address

Of the messages sent by the master station, the device creates response messages only when station addresses are the same. Station addresses in the messages are expressed as two-digit hexadecimal characters.

The station address is set up by the station address setup (setup setting C65).

However, when the station address is set to 0 (30H 30H), the device creates no response even if station addresses match.

The device returns the same station address as that of the received message.

• Sub-address

The C35/36 does not use the sub-address. For this reason, set "00" (30H 30H).

The device returns the same sub-address as that of the received message.

• Device code

The device sets X (58H) or x (78H) as the device code. This code is determined for each device series, and other codes cannot be selected. The device returns the same device code as that of the received message. X (58H) is used as the default, and x (78H) is used for judging the message as the resend message.

• ETX

ETX indicates the end of the application layer.

• Checksum

This value is for checking whether or not some abnormality (e.g. noise) causes the message content to change during communications.

The checksum is expressed as two hexadecimal characters.

- How to calculate a checksum
 - (1) Add the character codes in the message from STX through ETX in single byte units.
 - (2) Take two's complement of the low-order one byte of the addition result.
 - (3) Convert the obtained two's complement to a two-byte ASCII code.

The following is a sample checksum calculation:

[Sample message]

```

STX: 02H
'0': 30H (first byte of the station address)
'1': 31H (second byte of the station address)
'0': 30H (first byte of the sub-address)
'0': 30H (second byte of the sub-address)
'X': 58H (device code)
'R': 52H (first byte of the command)
'S': 53H (second byte of the command)
(omitted)
ETX: 03H
    
```

- (1) Add the character codes in the message from STX through ETX in single byte units.

The add operation in single byte units is as follows:
 $02H + 30H + 31H + 30H + 30H + 58H + 52H + 53H + \dots + 03H$.
 Assume that the result is 376H.

- (2) The low-order one byte of the addition result 376H is 76H. The two's complement of 76H is 8AH.
- (3) Convert the obtained 8AH to a two-byte ASCII code.

The result is:
 '8': 38H
 'A': 41H,
 and the two bytes, '8'(38H) and 'A'(41H), are the checksum.

- CR/LF

This indicates the end of the message. Immediately after LF is received, the device enters a state allowed to process the received message.

■ Application layer

The table below shows the configuration of the application layer.

Item	Description
Command	"RS" (decimal number format continuous address data read command)
	"WS" (decimal number format continuous address data write command)
	"RD" (hexadecimal number format continuous address data read command)
	"WD" (hexadecimal number format continuous address data write command)
Data delimiter	RS, WS: "," (comma) RD, WD: None
Word address	RS, WS: "501W", etc. RD, WD: "01F5", etc.
Read count	Numerical value of characters expressed as "1" for example
Numerical value to be written	RS, WS: Numerical value of characters expressed as "100" for example RD, WD: Numerical value of characters expressed in hexadecimal as "0064" for example

4 - 3 Description of Commands

■ Continuous data read command (RS command)

This command reads data of continuous addresses by a single command.

● Send message

This command enables the content of continuous data addresses starting with the specified read start address to be read as a single message. The figure below shows the structure of the application layer of the send message when the data is read.

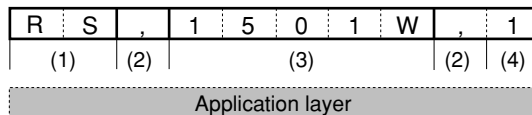

- (1) Continuous read command
- (2) Data delimiter
- (3) Data address
- (4) Number of read data

● Response message

If the message is correctly received, a response message corresponding to the command content is returned.

The figure below shows the structure of the application layer of the response message when the data is read.

- Normal termination (reading of single data item)

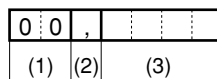

- Normal termination (reading of multiple data items)

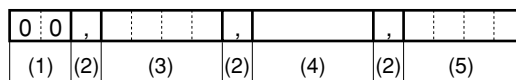

- Abnormal termination

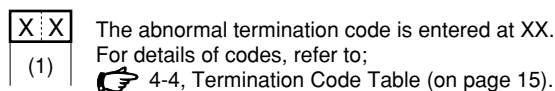

- (1) Termination code
- (2) Data delimiter
- (3) Data
- (4) Data 2 to (n-1)
- (5) Data n

● Maximum number of read data per message

Up to 10 words for both RAM and EEPROM areas

■ Continuous data write command (WS command)

This command writes data to continuous addresses.

● Send message

The figure below shows the structure of the application layer of the send message for the data write command.

W	S	,	1	5	0	1	W	,	1	,	6	5
(1)	(2)		(3)				(2)	(4)	(2)		(5)	

- (1) Write command
- (2) Data delimiter
- (3) Start write data address
- (4) Write data (first word)
- (5) Write data (second word)

● Response message

The figure below shows the structure of the application layer of the response message for the data write command.

- Normal termination

0	0
(1)	

- Abnormal termination or warning

X	X
(1)	

The abnormal termination code is entered at XX.
For details of codes, refer to;
 4-4, Termination Code Table (on page 15).

- (1) Termination code

● Maximum number of write data per message

Up to 10 words for both RAM and EEPROM areas

■ Continuous data read command (RD command)

This command reads continuous data in two-byte units. This command is suitable for handling data in ladder programs sent by PLC communications as the data is of a fixed length.

The start data address is expressed as four hexadecimal digits. The number of read data is expressed as four digits, and data is expressed as four X n (n is a positive integer) hexadecimal digits.

● Send message

The read start data address (four hexadecimal digits) and the number of read data (four hexadecimal digits) are sent.

R	D						
(1)	(2)	(3)					

- (1) Fixed length continuous data read command
- (2) Start data address
- (3) Number of read data

● Response message

If the message is sent successfully, the termination code is taken to be normal (two decimal digits) and returned appended with the number of read data (four hexadecimal digits X number of read data) specified by the command. If message transmission ends in error, the termination code is taken to be in error (two decimal digits) and returned without the read data.

- Normal termination (reading of single data item)

0	0				
(1)	(2)				

- Normal termination (reading of multiple data items)

0	0						
(1)	(2)	(3)	(4)				

- Abnormal termination

X	X				
(1)					

The abnormal termination code is entered at XX.
For details of codes, refer to;
☞ 4-4, Termination Code Table (on page 15).

- (1) Termination code
- (2) Data
- (3) Data 2 to data (n-1)
- (4) Data n

● Maximum number of read data per message

Up to 10 words for both RAM and EEPROM areas

■ Continuous data write command (WD command)

This command writes continuous data in two-byte units. This command is suitable for handling data in ladder programs sent by PLC communications as the data is of a fixed length.

The start data address is expressed as four hexadecimal digits. Data is expressed as four X n (n is a positive integer) hexadecimal digits.

● Send message

The write start data address (four hexadecimal digits) and the number of write data (four X n hexadecimal digits) are sent.

- Writing of single data item

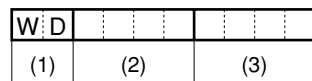

- Writing of multiple data items

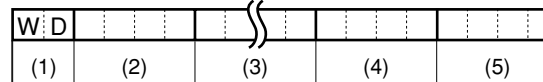

- (1) Fixed length continuous data write command
- (2) Start data address
- (3) Data 1
- (4) Data 2 to data (n-1)
- (5) Data n

● Response message

If writing is successful, the normal termination code (two decimal digits) is returned. If only part of the data is written, and the remaining data is not written, the warning termination code (two decimal digits) is returned. If none of the data is written, the abnormal termination code (two decimal digits) is returned.

- Normal termination



- Abnormal termination or warning



The abnormal termination code is entered at XX.
For details of codes, refer to;
☞ 4-4, Termination Code Table (on page 15).

- (1) Termination code

● Maximum number of write data per message

Up to 10 words for both RAM and EEPROM areas

4 - 4 Termination Code Table

When an error occurred in the application layer, an abnormal termination code is returned as a response message.

■ Normal and warning termination

Termination code	Type	Contents and action
00	Normal	Communications end normally.
21	Alarm	Wrote data in the address that could not be set in the communication due to the setup allotment by external switching inputs. The controller continues the process without writing any in the concerned address.
23	Alarm	The controller stops reading due to access to the address outside the scope. The controller stops writing due to access to the address outside the scope, however writes inside addresses.

■ Error termination

Termination code	Type	Contents and action
40	Error	“W” has not been set at the address. All messages are aborted.
41	Error	“WS”, or “RS” has not been set. All messages are aborted.
43	Error	ETX(03H) is not set in the correct position. “,” is not set after the address. All messages are aborted.
46	Error	The address is erroneous. All messages are aborted.
47	Error	There is an error in the number of word addresses to read. All messages are aborted.
48	Error	There is an error in the written numeric. Write has been executed, except for the error address.
99	Error	An undefined command or other message error. All messages are aborted.

4 - 5 Timing Specifications

■ Timing specifications for instruction and response message

The cautions below are required with regard to the timing to transmit a instruction message from the master station and a response message from the slave station.

● Response monitor time

The maximum response time from the end of the instruction message transmission by the master station until when the master station receives a response message from the slave station is two seconds ((1) in the figure below). So, the response monitor time should be set to two seconds.

Generally, when a response time-out occurs, the instruction message is resent. For details, see Chapter 6 “COMMUNICATION PROGRAM FOR MASTER STATION.”

● Transmission start time

A wait time of 10ms is required before the master station starts to transmit the next instruction message (to the same slave station or a different slave station) after the end of receiving response message ((2) in the figure below).

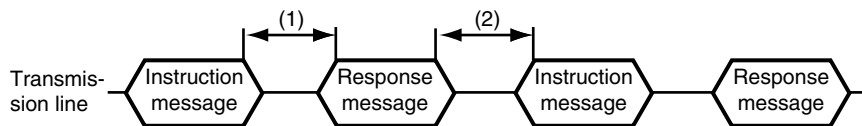

- (1) End of master station transmission -
Transmission start time of slave station = Max. 2000ms
- (2) End of slave station transmission -
Transmission start time of master station = Min. 10ms

■ RS-485 driver control timing specifications

When the transmission/reception on the RS-485 3-wire system is directly controlled by the master station, care should be paid to the following timing:

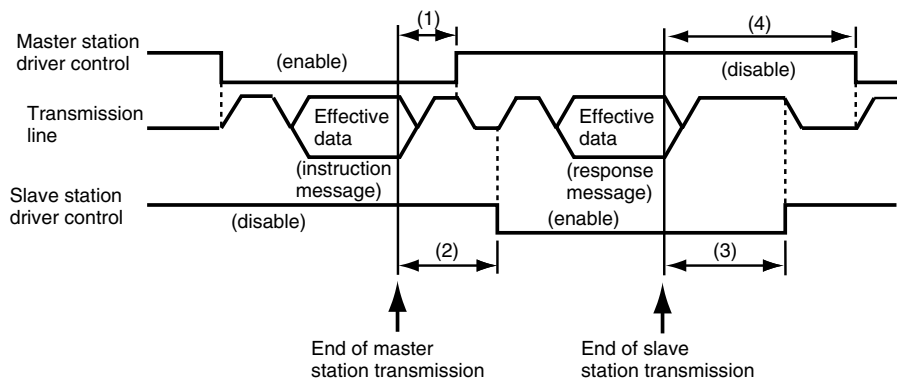

- (1) End of master station transmission - Driver disable time = 500µs max.
- (2) End of slave station reception - Driver enable time = 15ms min.
- (3) End of slave station transmission - Driver disable time = 10ms max.
- (4) End of master station reception - Driver enable time = 10ms min.

■ **Other precautions**

- The time required for the master station to finish the transmittal of instruction message and for the slave station to start the transmittal of response message becomes longer if the number of data to write and read increases. When the faster response time is required by the slave station, make sure to keep the number of data to read / write at the minimum in one message.
- When the number of data is one data to read / write in one message, the time required for the master station to finish the instruction message and for the slave station to transmit the response message is about 30ms.

Chapter 5. COMMUNICATION DATA TABLE

5 - 1 Basic Communication Data Processing

■ Communication data types and formats

● Types of communication data

The communications data are categorized as follow:

- Device related data
- Operating status related data
- Instantaneous flow rate related data
- Integrated flow related data
- Function setup related data
- Parameter setup related data

● Format of communication data

Communication data is classified into the following formats:

- Numeric data: Data indicating a numeric value (PV, SP, etc.).
- Bit data: Data where each bit is significant (alarms, etc.). Bit data must be composed by transmission and decomposed by reception.

IMPORTANT

If it is necessary to change the parameters of the CMQ Series frequently by communication, write data at addresses of RAM. The guaranteed data write count at the EEPROM addresses is limited to 100,000 times.
Note that the data in RAM is cleared, and the data in EEPROM is copied on RAM if the power supply to the CMQ Series interrupted.

■ Communication data storage memory

● Memory type

The communication data are stored in the following two types of memory:

- RAM: Stored data is cleared when the power is turned OFF. However data can be written to this memory any number of times.
- EEPROM: Stored data is retained even when the power is turned OFF, whereas data write operations are limited to a total of 100,000 times owing to device characteristics.

● Communication object memory

In communication, it is necessary to read/write data from/into the abovementioned two types of memory according to the purpose and use. There is a difference between the object memories as follows:

- RAM: Data is read/written from/into RAM only. If the power supply is turned off after writing data into RAM, and then it is turned on again, the data in EEPROM is copied on RAM, so the data in RAM becomes the same as in EEPROM.
- EEPROM: Data are written in both RAM and EEPROM.

■ Data address

The data addresses are allocated as shown in the table below.

Communication data	RAM		EEPROM	
	Offset value Decimal (Hexadecimal)	Address Decimal (Hexadecimal)	Offset value Decimal (Hexadecimal)	Address Decimal (Hexadecimal)
Device related data	1000 (03E8)	1001 to 1199 (03E9 to 04AF)	4000 (0FA0)	4001 to 4199 (0FA1 to 1067)
Operating status related data	1200 (04B0)	1201 to 1399 (04B1 to 0577)	4200 (1068)	4201 to 4399 (1069 to 112F)
Instantaneous flow- rate related data	1400 (0578)	1401 to 1599 (0579 to 063F)	4400 (1130)	4401 to 4599 (1131 to 11F7)
Integrated flow rate related data	1600 (0640)	1601 to 1799 (0641 to 0707)	4600 (11F8)	4601 to 4799 (11F9 to 12BF)
Function setup related data	2000 (07D0)	2001 to 2199 (07D1 to 0897)	5000 (1388)	5001 to 5199 (1389 to 144F)
Parameter setup related data	2200 (0898)	2201 to 2399 (0899 to 095F)	5200 (1450)	5201 to 5399 (1451 to 1517)

■ Data read / write count

The number of data which can be continuously read/written by once communication is as shown in the table below.

	RAM	EEPROM
Read	1 to 10	1 to 10
Write	1 to 10	1 to 10

■ Data unit and decimal point position

Read/write data is not appended with a decimal point.

The unit and decimal point position is determined for each data item.

For details on the data unit and decimal point position, see the **CMQ-V Series Digital Mass Flow Controller User's manual No.CP-SP-1204E** or **CMQ-V Series Digital Mass Flow Controller (For Hydrogen and Helium Gases) User's manual No.CP-SP-1205E**.

5 - 2 Communication Data Table

The enabling conditions for the address and R/W (Read/Write) of each data are specified in the following table:

The meaning of R/W column marks:

○ Possible

× Impossible

■ Device related data

Note

- For RD and WD commands, the data is required four hexadecimal digits.

Item	Data range	RAM			EEPROM			Remarks
		Address Decimal (Hexadecimal)	R	W	Address Decimal (Hexadecimal)	R	W	
Gas type	0: User setting 1: Nitrogen/Air 2: Oxygen 3: Argon 4: Carbon dioxide 5: Natural gas 13A (Heating value: 46MJ/m ³) 6: Propane 7: Methane 8: Butane 9: Hydrogen 10: Helium 11: Natural gas 13A (Heating value: 45MJ/m ³)	1001 (03E9)	○	×	4001 (0FA1)	×	×	Gas type change is possible by function setup (Address 5018)
Full- scale flow rate	Depend on flow rate range	1002 (03EA)	○	×	4002 (0FA2)	×	×	The decimal point is removed.
Decimal point position of instantaneous flow rate	0: No decimal point 1: XXXX. 2: XXX.X 3: XX.XX 4: X.XXX	1003 (03EB)	○	×	4003 (0FA3)	×	×	
Decimal point position of integrated flow rate	0: No decimal point 1: XXXXXXXX. 2: XXXXXXXX.X 3: XXXXXX.XX 4: XXXXX.XXX	1004 (03EC)	○	×	4004 (0FA4)	×	×	
Instantaneous flow rate unit	0: mL/min 1: L/min	1005 (03ED)	○	×	4005 (0FA5)	×	×	
Integrated flow rate unit	0: L 1: m ³	1006 (03EE)	○	×	4006 (0FA6)	×	×	

■ Operating status related data

Note

- For RD and WD commands, the data is required four hexadecimal digits.
- The flow rate unit "L/min" becomes "mL/min" in MQV9200.

Item	Data range	RAM			EEPROM			Remarks
		Address Decimal (Hexadecimal)	R	W	Address Decimal (Hexadecimal)	R	W	
Alarm status bit	Refer to *1	1201 (04B1)	○	×	4201 (1069)	×	×	For RS command, status is shown in decimal numbers
Event status bit	Refer to *2	1202 (04B2)	○	×	4202 (106A)	×	×	For RS command, status is shown in decimal numbers
Control status bit	Refer to *3	1203 (04B3)	○	×	4203 (106B)	×	×	For RS command, status is shown in decimal numbers
Operation mode	0: Valve full close 1: Valve control 2: Valve full open	1204 (04B4)	○	○	4204 (106C)	○	○	When the valve is in full close or full open by external inputs, write operation is disabled.
Instantaneous SP No. in use	0: SP-0 1: SP-1 2: SP-2 3: SP-3 4: SP-4 5: SP-5 6: SP-6 7: SP-7	1205 (04B5)	○	○	4205 (106D)	○	○	When SP No. switching is selected by external inputs, write operation is disabled. The value larger than the one selected with SP No.(Address 5004) of the function setup can not be written.
Instantaneous SP value in use	(0 to 100%FS) L/min	1206 (04B6)	○	×	4206 (106E)	×	×	The value in the data range (L/min) is the value removed decimal point that obtained by full scale flow rate multiplied by the percentage in parentheses.
Instantaneous PV value	(0 to 100%FS) L/min	1207 (04B7)	○	×	4207 (106F)	×	×	
Valve actuation current	0.0 to 100.0%	1208 (04B8)	○	×	4208 (1070)	×	×	The decimal point is removed .

*1 : Alarm status bit configuration (Address 1201) 0: Normal 1: Error

Bit No.	Description
0	Deviation lower limit alarm of instantaneous flow rate (AL01)
1	Deviation upper limit alarm of instantaneous flow rate (AL02)
2	Valve amperage lower limit alarm (AL11)
3	Valve amperage upper limit alarm (AL12)
4	Sensor error (common to AL81, AL82 and AL83)
5	Input / output adjustment data error (AL91)
6	Sensor calibration data error (AL92)
7	User setup data error (AL93)
8	Valve overheat prevention limit operation (AL71)
9	Sensor error 1 (AL81)
10	Sensor error 2 (AL82)
11	Sensor error 3 (AL83)

*2 : Event status bit configuration (Address 1202) 0: OFF 1: ON

Bit No.	Description
0	Event output 1 status
1	Event output 2 status
2	Undefined (0 fixed)
3	External contact 1 input status
4	External contact 2 input status
5	External contact 3 input status
6	External 3-stage switching input status 1 (0V input)
7	External 3-stage switching input status 2 (5V input)

*3 : Alarm status bit configuration (Address 1203) 0: OFF 1: ON

Bit No.	Description
0	OK lamp (PV control status) 0: Light-out 1: Lighting (Instantaneous PV OK)
1	Slow start operation 0: Normal operation 1: Slow start operation
2	Digital setting / Analog setting 0: Digital setting 1: Analog setting
3	Totalizing count status 0: Totalized flow PV < Totalized flow event SP 1: Totalized flow PV ≥ Totalized flow event SP
4	SP ramp control function 0: Function disabled 1: SP ramp control enabled
5	Undefined (0 fixed)
6	Undefined (0 fixed)
7	Undefined (0 fixed)

■ Flow set value

Note

- For RD and WD commands, the data is required four hexadecimal digits.
- The flow rate unit "L/min" becomes "mL/min" in MQV9200.

Item	Data range	RAM			EEPROM			Remarks
		Address Decimal (Hexadecimal)	R	W	Address Decimal (Hexadecimal)	R	W	
Flow set value SP-0	(0 to 100%FS) L/min	1401 (0579)	○	○	4401 (1131)	○	○	The value in the data range (L/min) is the value removed decimal point that obtained by full scale flow rate multiplied by the percentage in parentheses.
Flow set value SP-1	(0 to 100%FS) L/min	1402 (057A)	○	○	4402 (1132)	○	○	
Flow set value SP-2	(0 to 100%FS) L/min	1403 (057B)	○	○	4403 (1133)	○	○	
Flow set value SP-3	(0 to 100%FS) L/min	1404 (057C)	○	○	4404 (1134)	○	○	
Flow set value SP-4	(0 to 100%FS) L/min	1405 (057D)	○	○	4405 (1135)	○	○	
Flow set value SP-5	(0 to 100%FS) L/min	1406 (057E)	○	○	4406 (1136)	○	○	
Flow set value SP-6	(0 to 100%FS) L/min	1407 (057F)	○	○	4407 (1137)	○	○	
Flow set value SP-7	(0 to 100%FS) L/min	1408 (0580)	○	○	4408 (1138)	○	○	

■ Totalized flow related data

Note

- For RD and WD commands, the data is required four hexadecimal digits.

Item	Data range	RAM			EEPROM			Remarks
		Address Decimal (Hexadecimal)	R	W	Address Decimal (Hexadecimal)	R	W	
Totalized flow event setting lower 4 digits	0 to 9999	1601 (0641)	○	○	4601 (11F9)	○	○	Same as RAM address 2218 and 5218 in parameter set up.
Totalized flow event setting upper 4 digits	0 to 9999	1602 (0642)	○	○	4602 (11FA)	○	○	Same as RAM address 2219 and 5219 in parameter set up.
Totalized flow lower 4 digits	0 to 9999	1603 (0643)	○	○	4603 (11FB)	○	○	When resetting the totalized value, make sure to write "0" for the both lower and upper digits.
Totalized flow upper 4 digits	0 to 9999	1604 (0644)	○	○	4604 (11FC)	○	○	

■ Function setup related data

 **Note**

• For RD and WD commands, the data is required four hexadecimal digits.

Item	Data range	RAM			EEPROM			Remarks
		Address Decimal (Hexadecimal)	R	W	Address Decimal (Hexadecimal)	R	W	
Key lock Run	0: Key lock disabled 1: Settings other than instantaneous SP and integrated SP are key-locked 2: All settings key-locked	2001 (07D1)	<input type="radio"/>	<input type="radio"/>	5001 (1389)	<input type="radio"/>	<input type="radio"/>	
RUN key operation selection and operation mode selection when power turned ON	0: RUN key disabled (Operation starts in the control mode when the power is turned ON) 1: RUN key enabled (1) (Operation is started up in the operating mode used before power shut-down when the power is turned ON) 2: RUN key enabled (2) (Operation is started up in the fully closed mode when the power is turned ON)	2002 (07D2)	<input type="radio"/>	<input type="radio"/>	5002 (138A)	<input type="radio"/>	<input type="radio"/>	
Flow rate setup method (SP setup method selection)	0: Digital setup (set by key operation or communications) 1: Analog setup (set by external analog input voltage)	2003 (07D3)	<input type="radio"/>	<input type="radio"/>	5003 (138B)	<input type="radio"/>	<input type="radio"/>	
Number of flow set value selection (number of SPs selection)	0: Number of SPs = 1 (SP-0 only) 1: Number of SPs = 2 (SP-0, SP-1) 2: Number of SPs = 3 (SP-0 to SP-2) 3: Number of SPs = 4 (SP-0 to SP-3) 4: Number of SPs = 5 (SP-0 to SP-4) 5: Number of SPs = 6 (SP-0 to SP-5) 6: Number of SPs = 7 (SP-0 to SP-6) 7: Number of SPs = 8 (SP-0 to SP-7)	2004 (07D4)	<input type="radio"/>	<input type="radio"/>	5004 (138C)	<input type="radio"/>	<input type="radio"/>	
Input range selection of analog setup (analog SP input range selection)	(1) Analog output selection is set at voltage output ($\xi - 05 = 0, 1, 4, \text{ or } 5$). 0: 0 to 5V internal reference input 1: 0 to 5V external reference input 2: 1 to 5V external reference input	2005 (07D5)	<input type="radio"/>	<input type="radio"/>	5005 (138D)	<input type="radio"/>	<input type="radio"/>	

Item	Data range	RAM			EEPROM			Remarks
		Address Decimal (Hexadecimal)	R	W	Address Decimal (Hexadecimal)	R	W	
Input range selection of analog setup (analog SP input range selection)	(2)Analog output selection is set at current output ($\zeta - 05 = 2, 3, 6, \text{ or } 7$) 0 : 0 to 20mA external reference input 1 : 0 to 20mA external reference input 2 : 4 to 20mA external reference input	2005 (07D5)	○	○	5005 (138D)	○	○	
Analog output type and range selection (analog PV output range selection)	0: 0 to 5V instantaneous flow rate output 1: 1 to 5V instantaneous flow rate output 2: 0 to 20mA instantaneous flow rate output 3: 4 to 20mA instantaneous flow rate output 4: 0 to 5V setting flow rate output 5: 1 to 5V setting flow rate output 6: 0 to 20mA setting flow rate output 7: 4 to 20mA setting flow rate output	2006 (07D6)	○	○	5006 (138E)	○	○	
Event 1 output type assignment	0: Not used (OFF fixed) 1: ON when the totalized	2007 (07D7)	○	○	5007 (138F)	○	○	
Event 2 output type assignment	flow event occurs 2: Totalized pulse output 3: ON when the flow rate is OK 4: ON in control mode 5: ON in fully open mode 6: ON in control or fully open mode 7: ON in fully closed mode 8: PV upper limit event 9: PV lower limit event 1 10: PV lower limit event 2 -1 to -10: Inverse output of above 1 to 10 (Normal operation: ON, Event occurrence: OFF)	2008 (07D8)	○	○	5008 (1390)	○	○	
External 3-stage switching function assignment	0: Not used 1: Switching of operating mode 1 2: Switching SP No. 3: Switching of totalizing operation 4: Switching of analog I/O voltage range (simultaneous external switching of $\zeta - 05$ and $\zeta - 06$) 5: Switching of operating mode 2	2009 (07D9)	○	○	5009 (1391)	○	○	

Item	Data range	RAM			EEPROM			Remarks
		Address Decimal (Hexadecimal)	R	W	Address Decimal (Hexadecimal)	R	W	
External contact input 1 function assignment	0: Not used 1: Reset totalized flow count 2: Stop totalizing flow count 3: Switching of SP No. 4: Switching of instantaneous flow rate setup method 5: Valve forced fully closed 6: Valve forced fully open 7: Switching of slow start operation or switching of instantaneous SP ramp control operation 8: Switching of operating mode (control by contact ON, forced fully closed by contact OFF) 9: Flow rate zero adjust- ment 10: Switching of gas type setup 11: Switching of flow rate range 12: Switching of SP ramp 13: Alarm reset	2010 (07DA)	○	○	5010 (1392)	○	○	
External contact input 2 function assignment		2011 (07DB)	○	○	5011 (1393)	○	○	
External contact input 3 function assignment		2012 (07DC)	○	○	5012 (1394)	○	○	
Automatic valve shut-off when the totalized flow event occurs	0: Function disabled 1: Function enabled	2013 (07DD)	○	○	5013 (1395)	○	○	
On/off of totalized flow reset function at start of control	0: Function disabled 1: Function enabled	2014 (07DE)	○	○	5014 (1396)	○	○	
Flow rate alarm setup type	0: Function disabled 1: Only upper limit alarm 2: Only lower limit alarm 3: Upper/lower limit alarm	2015 (07DF)	○	○	5015 (1397)	○	○	
Operation selection at alarm occurrence	0: Control continued (alarm ignored) 1: Forced fully closed 2: Forced fully open	2016 (07E0)	○	○	5016 (1398)	○	○	
Slow start setup	0: Slow start disabled 1 to 8: Slow start enabled (equivalent to approx. 1 to 6 seconds settling time)	2017 (07E1)	○	○	5017 (1399)	○	○	

Item	Data range	RAM			EEPROM			Remarks
		Address Decimal (Hexadecimal)	R	W	Address Decimal (Hexadecimal)	R	W	
Gas type selection 1	0: Conversion factor for each gas type set by the user 1: Air, nitrogen 2: Oxygen 3: Argon 4: Carbon dioxide (CO ₂) 5: Natural gas 13A (LNG) (Heating value: 46MJ/m ³) 6: 100% propane 7: 100% methane 8: 100% butane 9:Hydrogen 10:Helium 11: Natural gas 13A (LNG) (Heating value: 45MJ/m ³)	2018 (07E2)	○	○	5018 (139A)	○	○	*1
Flow rate display unit selection (reference conditions)	0: 20°C, 1 atmosphere 1: 0°C, 1 atmosphere 2: 25°C, 1 atmosphere 3: 35°C, 1 atmosphere	2019 (07E3)	○	○	5019 (139B)	○	○	
Valve amperage alarm setup type selection	0: Function disabled 1: Only upper limit alarm 2: Only lower limit alarm 3: Upper/lower limit alarms	2020 (07E4)	○	○	5020 (139C)	○	○	
Direct setup function ON/OFF	0: Function disabled 1: Function enabled	2021 (07E5)	○	○	5021 (139D)	○	○	
Control dead zone setting	0: Function disabled 1: Function enabled	2022 (07E6)	○	○	5022 (139E)	○	○	
PV filter (process for filtering of instantaneous flow rate)	0: Without filter 1: Two samplings moving average 2: Four samplings moving average 3: Eight samplings moving average	2023 (07E7)	○	○	5023 (139F)	○	○	

*1: The oxygen can not be set for other controllers except those shipped only for the oxygen gas application. The hydrogen and helium gases can not be set for other controllers not subject to hydrogen and helium gas applications. Also the controllers subjected to the hydrogen and helium gases can not be set for the standard gases of Items 1 to 8 and 11 given in the data range.

Item	Data range	RAM			EEPROM			Remarks
		Address Decimal (Hexadecimal)	R	W	Address Decimal (Hexadecimal)	R	W	
Flow rate range setup 1	0: Standard range 10 to 99: 10% to 99% of standard range. (When calculating the range reduction, the least sig- nificant digit is truncated.) -10 to -99: 10% to 99% of standard range. (When calculating the range reduction, the least sig- nificant digit is not truncated.)	2024 (07E8)	○	○	5024 (13A0)	○	○	
Flow rate range setup 2		2025 (07E9)	○	○	5025 (13A1)	○	○	
Gas type selection 2	0: Conversion factor for each gas type set by the user 1: Air, nitrogen 2: Oxygen 3: Argon 4: Carbon dioxide (CO ₂) 5: Natural gas 13A (LNG) (Heating value: 46MJ/m ³) 6: 100% propane 7: 100% methane 8: 100% butane 9: Hydrogen 10: Helium 11: Natural gas 13A (LNG) (Heating value: 45MJ/m ³)	2026 (07EA)	○	○	5026 (13A2)	○	○	*1
SP ramp control function	0: Function disabled 1: SP ramp control 1. (In SP ramp-up: ramp 1, in SP ramp-down: ramp 2) 2: SP ramp control 2. (In external contact OFF: ramp 1, in external contact ON: ramp 2)	2027 (07EB)	○	○	5027 (13A3)	○	○	
Analog scaling function	0: Function disabled 1: Function enabled	2028 (07EC)	○	○	5028 (13A4)	○	○	
Forced PV (instantaneous flow rate) zero function	0: Function disabled 1: Function enabled	2029 (07ED)	○	○	5029 (13A5)	○	○	

*1: The oxygen can not be set for other controllers except those shipped only for the oxygen gas application. The hydrogen and helium gases can not be set for other controllers not subject to hydrogen and helium gas applications. Also the controllers subjected to the hydrogen and helium gases can not be set for the standard gases of Items 1 to 8 and 11 given in the data range.

Item	Data range	RAM			EEPROM			Remarks
		Address Decimal (Hexadecimal)	R	W	Address Decimal (Hexadecimal)	R	W	
Station address setting	0: Communications function disabled 1 to 127: Station address	2030 (07EE)	○	×	5030 (13A6)	○	×	Though a normal termination code is returned after sending the write instruction message, the data cannot be written.
Transmission speed selection	0: 38400bps 1: 19200bps 2: 9600bps 3: 4800bps 4: 2400bps	2031 (07EF)	○	×	5031 (13A7)	○	×	
Data format selection	0: 8 data bits, even parity, 1 stop bit 1: 8 data bits, no parity, 2 stop bits	2032 (07F0)	○	×	5032 (13A8)	○	×	
SP limit function	0: SP limit function disabled 1: Only upper limit enabled 2: Only lower limit enabled 3: Upper and lower limits enabled	2035 (07F3)	○	○	5035 (13AB)	○	○	
Operational differential pressure setting (control optimization)	0: Low differential pressure ($50 \pm 50\text{kPa}$) 1: Standard differential pressure ($200 \pm 100\text{kPa}$) 2: High differential pressure ($300+0, -100\text{kPa}$)	2036 (07F4)	○	○	5036 (13AC)	○	○	This function is invalid for the MQV0050 (J, K).
Flow rate display unit change function	0: Flow rate is displayed in the standard flow rate unit. 1: Flow rate is displayed in [L/min] fixed. -1: Flow rate is displayed in [mL/min] fixed.	2037 (07F5)	○	○	5037 (13AD)	○	○	This function is valid only for the MQV9200/9500/0002/0005.
PV (instantaneous flow rate) display decimal point position change function	0: Decimal point position is not changed 1: Decimal point position is shifted one digit left -1: Decimal point position is shifted one digit right	2038 (07F6)	○	○	5038 (13AE)	○	○	

■ Parameter setup related data

 **Note**

- For RD and WD commands, the data is required four hexadecimal digits.
- When the function setup is not valid, parameter setup is invalid.
- The decimal point of all data is removed.

Item	Data range	RAM			EEPROM			Remarks
		Address Decimal (Hexadecimal)	R	W	Address Decimal (Hexadecimal)	R	W	
Instantaneous flow rate O.K judgment range	(0.5 to 100%FS)	2201 (0899)	○	○	5201 (1451)	○	○	Unit: L/min (standard) (mL/min (standard) for the MQV9200.)
Instantaneous flow rate O.K judgment hysteresis	(0.5 to 100%FS)	2202 (089A)	○	○	5202 (1452)	○	○	
Instantaneous flow rate deviation upper limit alarm	(0.5 to 100%FS)	2203 (089B)	○	○	5203 (1453)	○	○	
Instantaneous flow rate deviation upper limit alarm hysteresis	(0.5 to 100%FS)	2204 (089C)	○	○	5204 (1454)	○	○	
Instantaneous flow rate deviation lower limit alarm	(0.5 to 100%FS)	2205 (089D)	○	○	5205 (1455)	○	○	
Instantaneous flow rate deviation lower limit alarm hysteresis	(0.5 to 100%FS)	2206 (089E)	○	○	5206 (1456)	○	○	
Instantaneous flow rate deviation alarm judgment delay time	0.5 to 999.9s	2207 (089F)	○	○	5207 (1457)	○	○	
Event output 1 delay	0.0 to 999.9s	2208 (08A0)	○	○	5208 (1458)	○	○	Delay does not apply to totalizer pulse output.
Event output 2 delay	0.0 to 999.9s	2209 (08A1)	○	○	5209 (1459)	○	○	
User setup conversion factor	0.04 to 9.999	2210 (08A2)	○	○	5210 (145A)	○	○	
Valve amperage upper limit alarm	0.1 to 100.0%	2211 (08A3)	○	○	5211 (145B)	○	○	
Valve amperage lower limit alarm	0.0 to 99.9%	2212 (08A4)	○	○	5212 (145C)	○	○	
Event output 1 upper/ lower limit flow rate setup	(0 to 100%FS)	2213 (08A5)	○	○	5213 (145D)	○	○	Unit: L/min (standard) (mL/min (standard) for the MQV9200.)
Event output 2 upper/ lower limit flow rate setup	(0 to 100%FS)	2214 (08A6)	○	○	5214 (145E)	○	○	
SP ramp control ramp 1	MQV9200/9500: 0.0 to 999.9	2215 (08A7)	○	○	5215 (145F)	○	○	
SP ramp control ramp 2	MQV0002/0005: 0.000 to 9.999 MQV0010/0020/ 0050: 0.00 to 99.99 MQV0200/0500: 0.0 to 999.9 MQV1000: 0 to 9999	2216 (08A8)	○	○	5216 (1460)	○	○	

Item	Data range	RAM			EEPROM			Remarks
		Address Decimal (Hexadecimal)	R	W	Address Decimal (Hexadecimal)	R	W	
Analog scaling	(10 to 100% FS)	2217 (08A9)	○	○	5217 (1461)	○	○	Unit: L/min (standard) (mL/min (standard) (standard) for the MQV9200.)
Cumulative flow event setting (last 4 digits)	0 to 9999	2218 (08AA)	○	○	5218 (1462)	○	○	Same as address 1601 and 4601.
Cumulative flow event setting (first 4 digits)	0 to 9999	2219 (08AB)	○	○	5219 (1463)	○	○	Same as address 1602 and 4602.
PV forced zero function delay	0.0 to 999.9s	2220 (08AC)	○	○	5220 (1464)	○	○	
SP upper limit flow rate	(0 to 100% FS)	2221 (08AD)	○	○	5221 (1465)	○	○	Unit: L/min (standard) (mL/min (standard) for the MQV9200.)
SP lower limit flow rate	(0 to 100% FS)	2222 (08AE)	○	○	5222 (1466)	○	○	

Chapter 6. COMMUNICATION PROGRAM FOR MASTER STATION

6 - 1 Precautions for Programming

- The maximum response monitor time of the instrument is 2 seconds. So, set the response time-out to 2 seconds.
- If no response is obtained within 2 seconds, retransmit the same message.
- The above retransmission is required since a message may not be properly transmitted due to noise or the like during communications.

Note

When “X” is used as the device ID code in the instruction message, the device ID code of the response message also becomes “X”. Likewise, the code in the response message becomes “x” when “x” is used as the device code in the instruction message.

Use the “X” and “x” device ID codes alternately during message retransmission from the master station, to make it easier to identify whether the received response message is the current one or the preceding one.

6 - 2 Examples of Communication Program

The program in this section is written in Borland's C++Builder5.0 or Borland C++Compiler5.5 for Windows95/98/NT/2000.

This program is given here as a reference when the user makes a program, and does not assure all the operations.

You can download Borland C++Compiler5.5 from Borland Home Page.

■ Before executing the program

Make sure to check the settings for communications type, station address, transmission speed and data format of the instrument.

■ Executing the program

This program is used for reading and writing data. When the program is executed, the application layers of the instruction message and response message communicated are indicated.

```
command:RS,1001W,2
result:00,0,0
command:WS,1204W,2
result:00
```

Sample indication of execution results

● Processing of the sample program

- Communication settings
Call open() and initialize the RS-232C serial port.
- Command execution
Set a desired character string in 'command' and call AppCPL().

■ Data read/write sample program

! Handling Precautions

Yamatake won't be absolutely responsible for any trouble caused by applying this program sample.

```
//-----
// C++ Builder 5
// Borland C++
// bcc32 cpl.cpp
//
// cygwin + gcc
// gcc cpl.cpp
//
#include <stdio.h>
#include <windows.h>
#pragma hdrstop

#define COMRESENDNUM 2
#define BUFFERSIZE 4096
#define TIMEOUT 2000

HANDLE handle;
unsigned long ErrorCode;
bool CheckSum;

bool AppCPL( char* tosend, char * received );
int Open( void );
int Close( void );
bool Write( unsigned char *Mesg, unsigned long Size );
bool Read( unsigned char *Buffer, unsigned long SizeToRead,
           unsigned long *ReadSize, unsigned long *ErrFlag );
void CPLSum( unsigned char *str, int len, unsigned char *buf );

//-----
int main(int argc, char* argv[])
{
    char command[255];
    char recieve[255];

    handle = (void *)0xffffffff;
    ErrorCode = 0;
    CheckSum = true;

    if(Open()==0){
        strcpy(command,"RS,1000W,2");
        AppCPL(command,recieve);
        printf("command:%s\n",command);
        printf("result:%s\n",recieve);

        strcpy(command,"WS,1000W,2");
        AppCPL(command,recieve);
        printf("command:%s\n",command);
        printf("result:%s\n",recieve);
        Close();
        getchar();
    }
    return 0;
}

//-----
int Open(void)
{
    COMMTIMEOUTS Timeouts;
    _DCB DCB;

    handle = CreateFile( "¥¥¥¥.¥¥COM1", GENERIC_READ|GENERIC_WRITE,
                        0, 0, OPEN_EXISTING, FILE_ATTRIBUTE_NORMAL, 0 );
    if( handle==(void *)0xffffffff ) return 3;

    if( !SetupComm( handle, BUFFERSIZE, BUFFERSIZE ) ){
        CloseHandle( handle );
        handle = (void*)0xffffffff;
        return 4;
    }
}
```

```

    if( !PurgeComm( handle, PURGE_TXABORT|PURGE_RXABORT|
        PURGE_TXCLEAR|PURGE_RXCLEAR ) ){
        CloseHandle( handle );
        handle = (void*)0xffffffff;
        return 5;
    }

    Timeouts.ReadIntervalTimeout      = 0xFFFFFFFF;
    Timeouts.ReadTotalTimeoutMultiplier = 0;
    Timeouts.ReadTotalTimeoutConstant = 0;
    Timeouts.WriteTotalTimeoutMultiplier = 0;
    Timeouts.WriteTotalTimeoutConstant = 0;

    if( !SetCommTimeouts( handle, &Timeouts ) ){
        CloseHandle( handle );
        handle = (void*)0xffffffff;
        return 6;
    }

    if( !GetCommState( handle, &DCB ) ){
        CloseHandle( handle );
        handle = (void*)0xffffffff;
        return 7;
    }

    DCB.BaudRate=CBR_19200;
    DCB.fBinary=1;
    DCB.fParity= 1;
    DCB.ByteSize=0x08;
    DCB.Parity=EVENPARITY;
    DCB.StopBits=ONESTOPBIT;

    if( !SetCommState( handle, &DCB ) ){
        CloseHandle( handle );
        handle = (void*)0xffffffff;
        return 8;
    }

    return 0;
}

int Close( void )
{
    if( handle!=(void *)0xffffffff ){
        if( !SetCommMask( handle, 0 ) ){
            CloseHandle( handle );
            handle = (void*)0xffffffff;
            return 2;
        }
        if( !EscapeCommFunction( handle, CLRDTR ) ){
            CloseHandle( handle );
            handle = (void*)0xffffffff;
            return 3;
        }
        if( !CloseHandle( handle ) ) return 4;
        handle = (void*)(0xffffffff);
    }else{
        return 1;
    }

    return 0;
}

//-----
bool Write( unsigned char *Mesg, unsigned long Size )
{
    unsigned long Error;
    unsigned long Errors;
    unsigned long SizeWritten;
    COMSTAT Stat;

    if( handle==(void *)0xffffffff ){
        return false;
    }
    if( Size>BUFFERSIZE ){
        printf( "unsigned long size" );
        return false;
    }
}

```



```

        }else{
            Buffer[(*ReadSize)++] = *cptr;
            if( (*ReadSize)>=SizeToRead ){
                goto OutOfWhile;
            }
        }
    }
    Sleep(1);
    dtime = GetTickCount() - stime;
}while( (SizeToRead>*ReadSize) && (dtime<TIMEOUT) );

OutOfWhile:

    if( ((SizeToRead>*ReadSize)&&(SizeToRead!=0xFFFFFFFF))||(*ReadSize==0) ){
        *ErrFlag = 0x00010000;
        return false;
    }
    return true;
}
//-----
void CPLSum( unsigned char *str, int len, unsigned char *buf )
{
    int          num=0;
    unsigned char *ch;

    for( ch=&str[0] ; ch<&str[len] ; ch++ ) num += *ch;
    num = -(num&0x000000FF)&0x000000FF);
    sprintf( (char*)buf, "%02X", num );
}
//-----

bool AppCPL( char* tosend, char * received )
{
    unsigned char  theMsg[BUFFERSIZE];
    unsigned char  theApp[BUFFERSIZE];
    unsigned char  theHdr[16];
    unsigned long  SzToSnd;
    unsigned long  RdSz;
    unsigned long  ErrFlg;
    bool          rt;
    int           Cnt=0;
    unsigned char  Sum[4];
    char          *etx;

    if( handle==(void*)(0xFFFFFFFF) ){
        return false;
    }

    ZeroMemory( theMsg, BUFFERSIZE );
    sprintf( (char*)theHdr, "%x02%x30%x31%x30%x30%x58" );
    sprintf( (char*)theMsg, "%s%s%x03", theHdr, tosend );

    if( CheckSum ){
        SzToSnd = strlen( (char*)theMsg );
        CPLSum( theMsg, SzToSnd, &theMsg[SzToSnd] );
    }
    strcat( (char*)theMsg, "%r%n" );
    SzToSnd = strlen( (char*)theMsg );

resend:
    Write( theMsg, SzToSnd );
    rt = Read( theMsg, 0xFFFFFFFF, &RdSz, &ErrFlg );

    if( !rt ){
        if(Cnt++ < COMRESENDNUM ){
            goto resend;
        }
        if( ErrFlg ){
            ErrorCode = ErrFlg;
        }else{
            ErrorCode = 0x000f0000;
        }
        return false;
    }
}

```

```

}else{
    if( strcmp( (char*)theMsg, (char*)theHdr, 6 )!=0 ){
        ErrorCode = 0x00020000;
        if( Cnt++<COMRESENDNUM ){
            goto resend;
        }
        return false;
    }
    if( CheckSum ){
        CPLSum( theMsg, RdSz-4, Sum );
        if( (theMsg[RdSz-4]!=Sum[0])|| (theMsg[RdSz-3]!=Sum[1]) ){
            ErrorCode = 0x00040000;
            if( Cnt++<COMRESENDNUM ){
                goto resend;
            }
            return false;
        }
    }
    ZeroMemory( theApp,BUFFERSIZE );
    CopyMemory( theApp, &theMsg[6], RdSz-6 );
    etx = strstr( (char*)theApp, "¥x03" );

    if( etx==NULL ){
        ErrorCode = 0x00200000;
        if( Cnt++<COMRESENDNUM ){
            goto resend;
        }
        return false;
    }else{
        *etx = 0x00;
    }
    strcpy( received, (char*)&theApp[0] );
}
return true;
}
//-----

```

Chapter 7. TROUBLESHOOTING

■ Check items in case communication is disabled

- (1) Check the power supply.
- (2) Check the wiring.
- (3) Check if the communication conditions for the CMQ-V Series meet those for the host computer.
If any one of the following setting items is different between both stations, communication is disabled:
The underlined items mean that they can be set on the CMQ-V Series side.
Transmission speed : 38400, 19200, 9600, 4800, 2400bps
Data length : 7, 8 bits
Parity : No parity, odd parity, even parity
Stop bit : 1 stop bit, 2 stop bits
- (4) Check if the destination address of the command frame transmitted from the host computer meets the address set to the CMQ-V Series.
The address of the CMQ-V Series set to “0” for factory setting.
Even when the destination address of the command frame is set to 00 (30H, 30H), the CMQ-V Series does not respond to such a message.
- (5) Use the upper-case character codes for all the character codes other than the device code (“X” or “x” in this controller).
- (6) Are those multi-dropped controllers belong operated themselves with different device address setups?
- (7) Is the communication timing conformed with the Chapter 4-5 Timing Specifications (page 16)?

Chapter 8. SPECIFICATIONS

■ RS-485 specifications

Item	Remarks
Transmission mode	Balanced
Transmission line	3-wire system
Transmission speed (bps)	2400, 4800, 9600, 19200, 38400
Transmission distance	500m max. (300m when connected with the MA500DIM and CMC410.)
Communications flow	Half duplex
Synchronization	Start-stop synchronization
Data format	8 data bits, 1 stop bit, even parity 8 data bits, 2 stop bits, no parity
Error detection	Parity check, checksum
Station address	0 to 127 (Communication function is inhibited when set to "0".)
Network type	1: N (31 units max.)
The rest of items	Conforms to RS-485 interface specifications.

APPENDIX

■ Code table

Upper Lower	0	1	2	3	4	5	6	7
0			Space	0	@	P	`	p
1			!	1	A	Q	a	q
2	STX		"	2	B	R	b	r
3	ETX		#	3	C	S	c	s
4			\$	4	D	T	d	t
5			%	5	E	U	e	u
6			&	6	F	V	f	v
7			'	7	G	W	g	w
8			(8	H	X	h	x
9)	9	I	Y	i	y
A	LF		*	:	J	Z	j	z
B			+	;	K	[k	{
C			,	<	L	\	l	
D	CR		-	=	M]	m	}
E			.	>	N	^	n	~
F			/	?	O	_	o	^

The shaded parts of the table above () are not used for this communication system.

■ Connection with CMC10L

The CMC10L001A000 is available as an RS-232C/RS-485 (3-wire system) converter from Yamatake's. The following diagram shows an example of wiring using a straight cable for a host computer in the terminal mode:

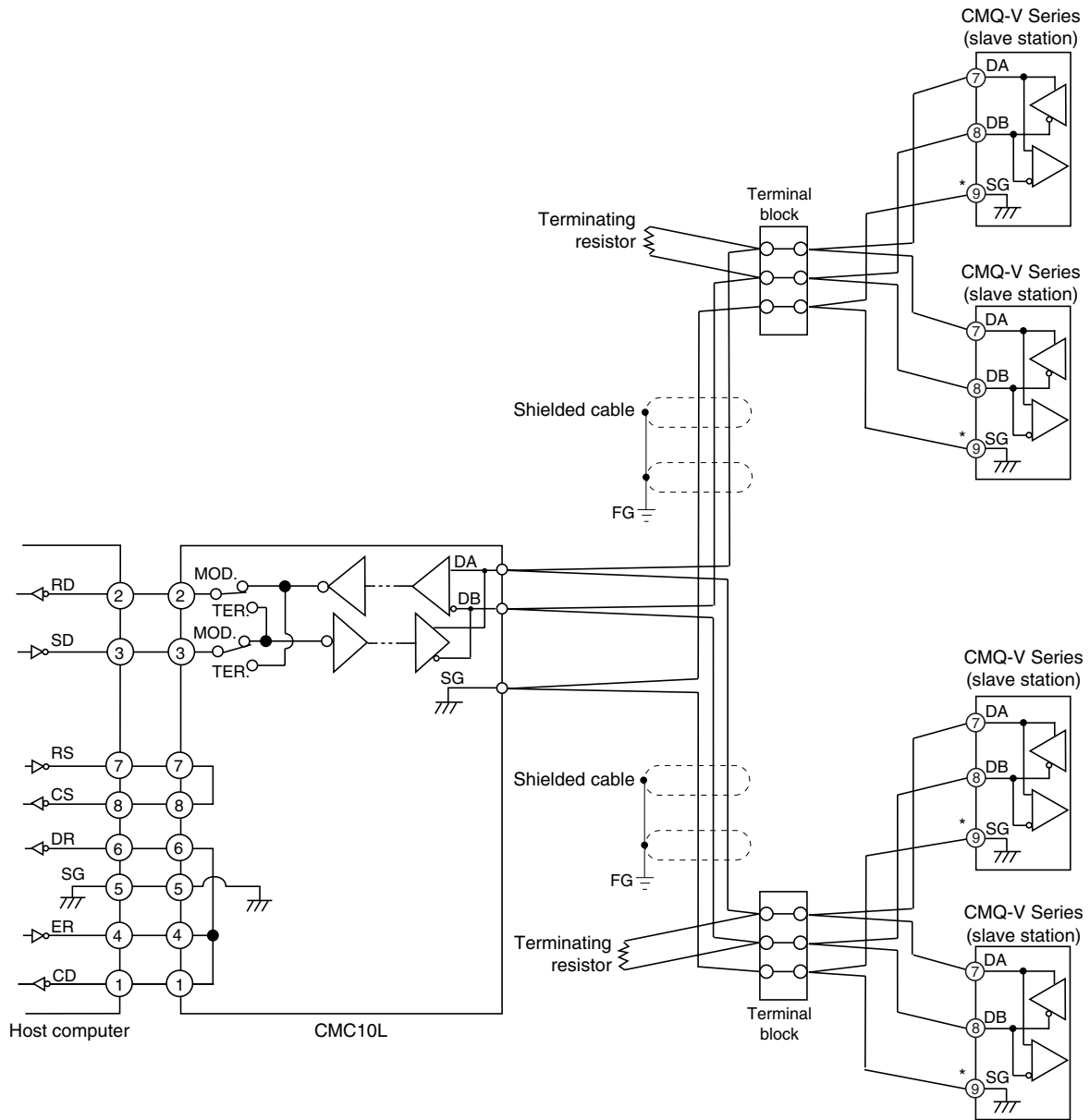

* : The pin No. 6 can be used as SG.

- Connect terminating resistors of $150\Omega \pm 5\%$, 1/2W min. at each end of the transmission line.
- Terminal block is required for the CMQ-V series because of the connector type connection.
- The cable to the terminal block from the CMQ-V series must be as short as possible.
- The FG grounding must not be made at the both shielded wire ends but only at one location.

! Handling Precautions

Be sure to connect SG terminals each other. Failure to do so might cause unstable communications.

Connect the master station SD to the slave station RD, and the master station RD to the slave station SD.

To execute this connection, set the MODE switch provided in the CMC10L as shown in the following table in accordance with the host computer side RS-232C connector pin arrangement (modem/terminal) and the type of cable (cross/straight) used:

RS-232C	Cable type	MODE switch
TERMINAL	Straight	MODEM
TERMINAL	Cross	TERMINAL
MODEM	Straight	TERMINAL
MODEM	Cross	MODEM

● RS-232C cable

Straight: An RS-232C cable with a D-Sub (9-pin) connector at each end where pins with the same number are mutually connected (for example, pin 2 to pin 2, and pin 3 to 3)

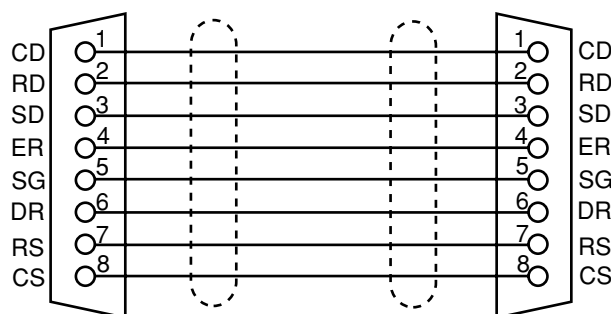

Cross: An RS-232C cable with a D-Sub (9-pin) connector at each end where different number pins are connected (for example, pin 2 to pin 3, and pin 3 to pin 2)

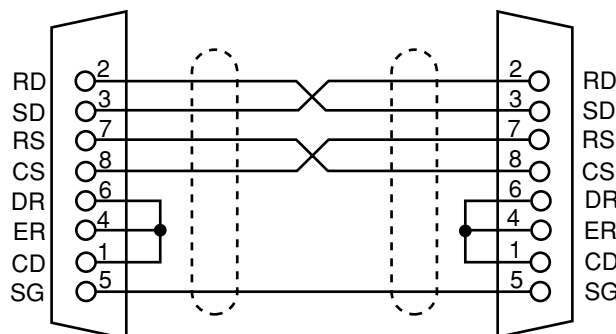

D-Sub (25-pin) – D-Sub (9-pin) conversion cable:

An RS-232C cable for conversion between D-Sub (25-pin) and D-Sub (9-pin)

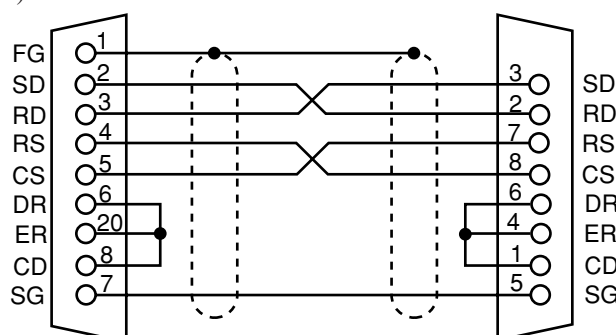

azbil

Yamatake Corporation
Advanced Automation Company

1-12-2 Kawana, Fujisawa
Kanagawa 251-8522 Japan

URL: <http://www.azbil.com>

Printed on recycled paper. (07)

Specifications are subject to change without notice.

Printed in Japan.
1st Edition: Issued in Jan. 2007 (U)