



Gas Flow Monitor CMG Series User's Manual



Thank you for purchasing the CMG Series Gas Flow Monitor.

This manual contains information for ensuring correct use of the CMG. It also provides necessary information for installation, maintenance, and troubleshooting.

This manual should be read by those who design and maintain devices that use the CMG Series.

Be sure to keep this manual nearby for handy reference.

RESTRICTIONS ON USE

When using this product in applications that require particular safety or when using this product in important facilities, pay attention to the safety of the overall system and equipment. For example, install fail-safe mechanisms, carry out redundancy checks and periodic inspections, and adopt other appropriate safety measures as required.

REQUEST

Ensure that this User's Manual is handed over to the user before the product is used.

Copying or duplicating this User's Manual in part or in whole is forbidden. The information and specifications in this User's Manual are subject to change without notice.

Considerable effort has been made to ensure that this User's Manual is free from inaccuracies and omissions.

If you should find any inaccuracies or omissions, please contact Yamatake Corporation.

In no event is Yamatake Corporation liable to anyone for any indirect, special or consequential damages as a result of using this product.

©2001 Yamatake Corporation ALL RIGHTS RESERVED

μF® is a registered trademark of Yamatake Corporation.

CMG Series is a trademark of Yamatake Corporation.

SAFETY PRECAUTIONS

■ About Icons

Safety precautions are for ensuring safe and correct use of this product, and for preventing injury to the operator and other people or damage to property. You must observe these safety precautions. The safety precautions described in this manual are indicated by various icons.

The following describes the icons and their meanings. Be sure to read and understand the following descriptions before reading this manual.



WARNING

Warnings are indicated when mishandling this product might result in death or serious injury to the user.







CAUTION

Cautions are indicated when mishandling this product might result in minor injury to the user, or only physical damage to this product.









■ Examples

	<p>Triangles warn the user of a possible danger that may be caused by wrongful operation or misuse of this product.</p> <p>These icons graphically represent the actual danger. (The example on the left warns the user of the danger of electrical shock.)</p>
	<p>White circles with a diagonal bar notify the user that specific actions are prohibited to prevent possible danger.</p> <p>These icons graphically represent the actual prohibited action. (The example on the left notifies the user that disassembly is prohibited.)</p>
	<p>Black filled-in circles instruct the user to carry out a specific obligatory action to prevent possible danger.</p> <p>These icons graphically represent the actual action to be carried out. (The example on the left instructs the user to remove the plug from the outlet.)</p>

WARNING

	<p>When using combustion gas, install the device at the upstream of the safety shut-off valve. If air enters the piping, and the sensor sparks due to lightning when an explosive mixture is present, an internal pipe explosion may be caused.</p>
	<p>The device is intended for use with city gas 13A, air, propane, and butane. Do not use the device for other type of gases. Also, use of the device for gases having an ignition temperature lower than 365°C may cause internal pipe explosion as a result of air entering the pipe and explosive mixed gas coming into contact with the heater built into the sensor.</p>
	<p>Use the analog outputs and alarm contact outputs on the device for monitoring the gas flowrate of a burner or other equipment. Do not use these outputs in applications where safety will be impaired when an analog output abnormality or alarm contact output malfunction occurs.</p>
	<p>Before wiring the device, be sure to turn the power OFF. Failure to do so might cause electric shock.</p>

CAUTION

	<p>This device is a precision instrument. Do not drop it nor subject it to shock. Doing so might damage the device.</p>
	<p>Do not peel off the pipe connection port seals until immediately before you connect the piping. Doing so might allow foreign objects to enter the connector port and cause defective operation.</p>
	<p>On rusty piping, install a strainer at the upstream to prevent foreign matter from entering the device. Foreign matter may cause faulty operation.</p>
	<p>When wiring, take care not to tug the display. The components inside might become damaged.</p>
	<p>Be sure to use only rated fuses for replacement. Use of a non-rated fuse prevents the safety circuit from functioning properly.</p>
	<p>Be sure to check that the wiring is correct before you turn the power ON. Incorrect wiring may cause damage or malfunction.</p>
	<p>Connect the power supply last of all. Touching other terminals by mistake may cause electric shock or damage the device.</p>
	<p>Make sure that the load to be connected to terminals does not exceed the rating indicated in the specifications.</p>
	<p>Supply power of the same voltage as that indicated on the model No. label on the device.</p>

Contents

SAFETY PRECAUTIONS Conventions Used in This Manual

Chapter 1. INTRODUCTION

- Introduction..... 1
- Features 1
- Model selection guide..... 2

Chapter 2. NAMES AND FUNCTIONS OF PARTS

Chapter 3. MOUNTING AND WIRING

- Mounting..... 6
- Wiring..... 11

Chapter 4. OPERATION

- Displaying the flowrate 14
- Resetting alarms..... 15
- Resetting the integrated flowrate..... 15
- Displaying the total flowrate..... 16

Chapter 5. APPLICATION OPERATION

- 5-1 Function Setup 17
 - Setting operation 17
 - Function setup item list..... 18
- 5-2 Parameter Setup..... 19
 - Setting operation 19
 - Parameter setup item list..... 20

Chapter 6. MAINTENANCE AND TROUBLESHOOTING

- Remediating trouble 22
- How to replace the fuse..... 23

Chapter 7. SPECIFICATIONS

- Common specifications..... 24
- Individual specifications..... 25
- External dimensions..... 26

Conventions Used in This Manual

The following conventions are used in this manual.

 **Handling Precautions**

: Handling Precautions indicate items that the user should pay attention to when handling the **CMG**.

 **Note**

: Notes indicate useful information that the user might benefit by knowing.

(1), (2), (3)

: The numbers with the parenthesis indicate steps in a sequence or indicate corresponding parts in an explanation.

Chapter 1. INTRODUCTION

■ Introduction

The CMG gas flow monitor is a flowmeter for measuring the fuel flowrate of gas burners that use a microflow sensor chip, a thermal flow speed sensor made using Yamatake proprietary technology.

The CMG displays and outputs the volume flowrate in a standard state* and does not require conversion of temperature and pressure.

The CMG has the following functions: instantaneous flowrate display, integrated flowrate display, alarm contact output, instantaneous flowrate output according to analog output, integrated pulse or event output according to open collector output. These functions enable detailed air-fuel ratio management of burners and flowrate management of units.

* Factory setting is 0°C, 1 atmosphere.

(The reference temperature can be selected from 5°C, 10°C, 15°C, 20°C and 25°C according to the function settings.)

■ Features

- Installation of the compact and high-precision CMG is simple. It can also be mounted in any direction as the direction of the display can be changed.
- Gas flowrate can be measured and managed easily on the flowrate digital display and Hi, Lo, OVER and ALARM LED displays.
- Displaying on panels and flowrate management can be performed easily by output of the gas flowrate upper limit/lower limit settings and analog output of instantaneous flowrate.
- Fuel usage can be easily understood as the instantaneous flowrate and integrated flowrate displays can be switched by one-touch operation.
- Compensation of display values is not needed even if temperature and pressure change as the measurement method used is mass flow.
- A bypass structure using an orifice enables low pressure loss, and prevents the influence of mist, etc.
- Self-diagnostic functions simplify remedies during troubleshooting.

■ Model selection guide

Model selection guide

CMG I II III IV V VI VII VIII IX

● Air model

Basic model No.	I	II	III	IV	V	VI	VII	VII	IX	Description
	Pipe size	Pipe shape	Gas type	Flow range	Output	Pressure	Comm- nication	Power supply	Additional processing	
CMG										Gas flow monitor
	15									15A (1/2B)
	25									25A (1B)
	40									40A (1 1/2B)
	50									50A (2B)
		0								Rc screw
		1								JIS 10K flange (40A, 50A only)
			A							Air
				004						4m ³ /h(normal) (CMG15) *1
				010						10m ³ /h(normal) (CMG25) *1
				030						30m ³ /h(normal) (CMG25) *1
				080						80m ³ /h(normal) (CMG40, 50) *1
				150						150m ³ /h(normal) (CMG40, 50) *1
					0					1 to 5V output (4, 10, 30m ³ /h only)
					1					4 to 20mA + event output
						0				Low pressure *2
						1				Medium pressure (CMG250 30m ³ /h, and CMG400/401, CMG500/501) *2
							0			Not available
								0		24Vdc
								1		100Vac (50/60Hz)
								2		200Vac (50/60Hz)
									00	None
									D0	Inspection certificate provided
									Y0	Traceability certificate provided

● City gas (13A) model (LNG CH₄: 88%)

Basic model No.	I	II	III	IV	V	VI	VII	VII	IX	Description
	Pipe size	Pipe shape	Gas type	Flow range	Output	Pressure	Comm- nication	Power supply	Additional processing	
CMG										Gas flow monitor
	15									15A (1/2B)
	25									25A (1B)
	40									40A (1 1/2B)
	50									50A (2B)
		0								Rc screw
		1								JIS 10K flange (40A, 50A only)
			N							City gas 13A
				004						4m ³ /h(normal) (CMG15) *1
				010						10m ³ /h(normal) (CMG25) *1
				030						30m ³ /h(normal) (CMG25) *1
				080						80m ³ /h(normal) (CMG40, 50) *1
				150						150m ³ /h(normal) (CMG40, 50) *1
					0					1 to 5V output (4, 10, 30m ³ /h(normal) only)
					1					4 to 20mA + event output
						0				Low pressure *2
						1				Medium pressure (JIS 10K flange only)*2
							0			Not available
								0		24Vdc
								1		100Vac (50/60Hz)
								2		200Vac (50/60Hz)
									00	None
									D0	Inspection certificate provided
									Y0	Traceability certificate provided

● Propane model

Basic model No.	I Pipe size	II Pipe shape	III Gas type	IV Flow range	V Output	VI Pressure	VII Commu- nication	VIII Power supply	IX Additional processing	Description
CMG										Gas flow monitor
	15									15A (1/2B)
	25									25A (1B)
	40									40A (1 1/2B)
	50									50A (2B)
		0								Rc screw
			P							Propane
				002						2m ³ /h(normal) (CMG15) *1
				004						4m ³ /h(normal) (CMG25) *1
				010						10m ³ /h(normal) (CMG25) *1
				025						25m ³ /h(normal) (CMG40, 50) *1
				050						50m ³ /h(normal) (CMG40, 50) *1
					0					1 to 5V output (2, 4, 10m ³ /h(normal) only)
					1					4 to 20mA + event output
						0				Low pressure *2
							0			Not available
								0		24Vdc
								1		100Vac (50/60Hz)
								2		200Vac (50/60Hz)
									00	None
									D0	Inspection certificate provided
									Y0	Traceability certificate provided

● Butane model

Basic model No.	I Pipe size	II Pipe shape	III Gas type	IV Flow range	V Output	VI Pressure	VII Commu- nication	VIII Power supply	IX Additional processing	Description
CMG										Gas flow monitor
	15									15A (1/2B)
	25									25A (1 B)
	40									40A (1 1/2B)
	50									50A (2 B)
		0								Rc screw
			B							Butane (butane 75%, propane 25%)
				001						1m ³ /h(normal) (CMG15) *1
				003						3m ³ /h(normal) (CMG25) *1
				008						8m ³ /h(normal) (CMG25) *1
				020						20m ³ /h(normal) (CMG40, 50) *1
				040						40m ³ /h(normal) (CMG40, 50) *1
					0					1 to 5V output (1, 3, 8m ³ /h(normal) only)
					1					4 to 20mA + event output
						0				Low pressure *2
							0			Not available
								0		24Vdc
								1		100Vac (50/60Hz)
								2		200Vac (50/60Hz)
									00	None
									D0	Inspection certificate provided
									Y0	Traceability certificate provided

*1 "normal" refers to the volumetric flowrate (m³/h) after converting to 0°C, 1 atmosphere.

*2 Low pressure: Less than 100kPa
Medium pressure: Less than 1.0MPa

Chapter 2. NAMES AND FUNCTIONS OF PARTS

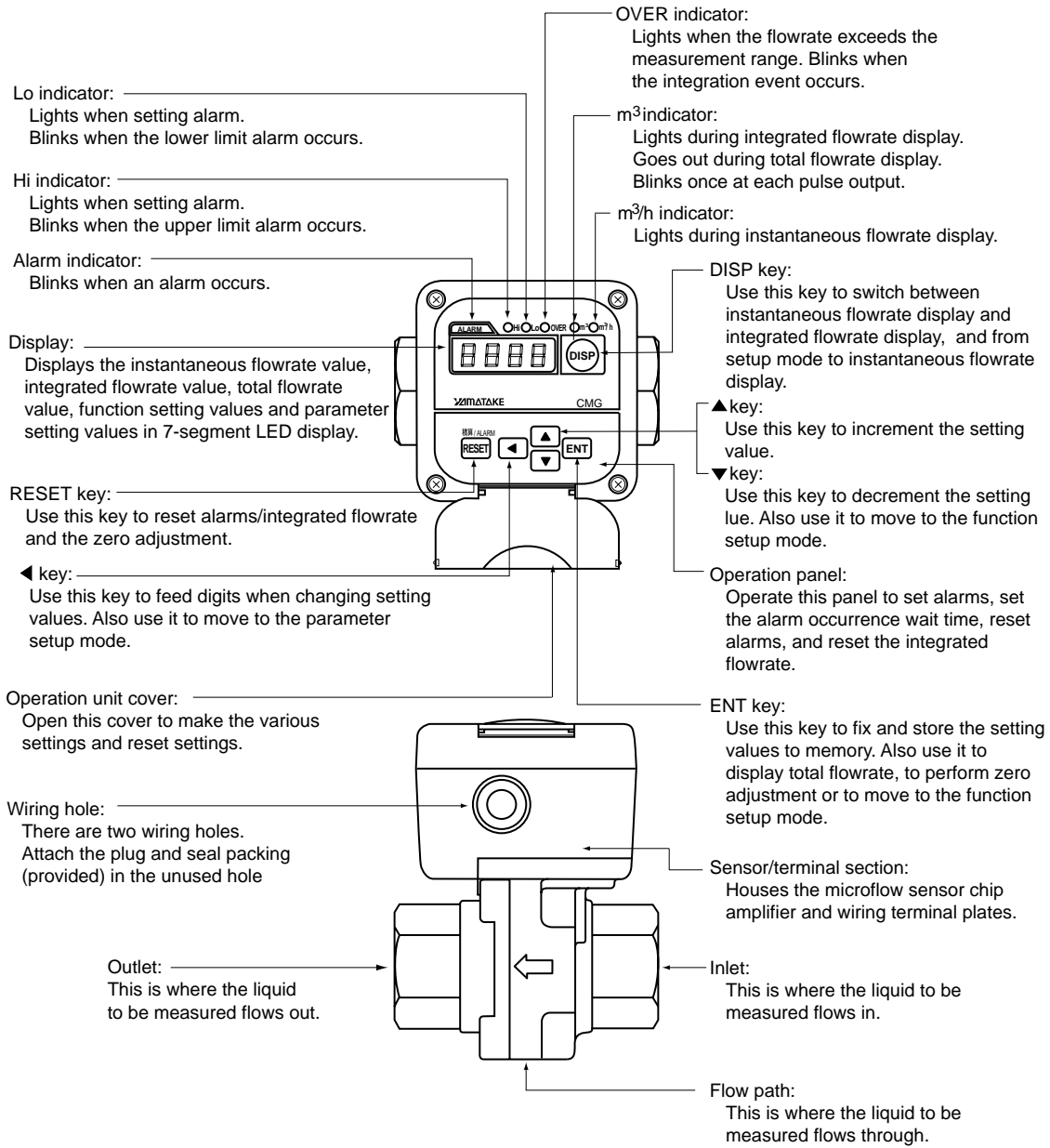

Fuse position

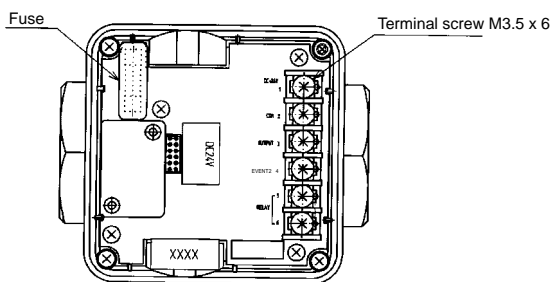

24Vdc power supply model

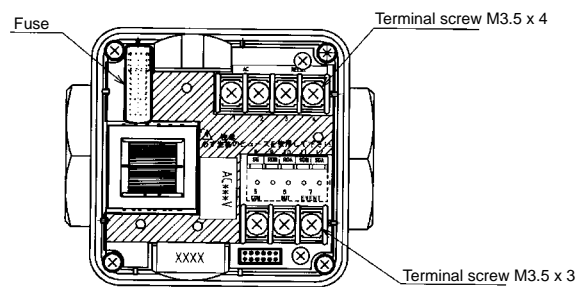

AC power supply model

Chapter 3. MOUNTING AND WIRING

WARNING



When using combustion gas, install the device at the upstream of the safety shut-off valve.

If air enters the piping, and the sensor sparks due to lightning when an explosive mixture is present, an internal pipe explosion may be caused.



On flange models, do not use the device or installed pipes as a foot rest.

Doing so might damage the device or piping, or cause you to slip which may result in injury.



Flange models are heavy. Dropping them on your feet may cause injury.

Handling Precautions

- When carrying the device, hold it by its flow path section. Holding it by its sensor/terminal section may damage the device.
- The device is a precision instrument. Do not drop it or subject it to shock. Doing so might damage the device.
- When connecting the device by screws, fasten the flow inlet section, and turn the pipe side to connect the piping.
- When connecting the device by a flange, first check the piping for tilting or out-of-center before installing.
Failure to do so might cause leakage.
- When mounting the device, firmly fasten to prevent vibration.
- Do not peel the protective seals from the display before use. When performing work on the device, tools may accidentally bump against the display and scratch it.
- When using the device outdoors, mount it out of the direct sunlight and at a location where it is not splashed directly with rain.
- When mounting the device in locations where rust, oil mist or dust and powder exists, be sure to provide a strainer at the upstream to prevent foreign matter from entering the device.
Foreign matter flowing into the device might result in faulty operation.
- When wiring the device, take care not to tug the display.
The internal connections might become damaged.
- Wire 1 to 5V output, 4 to 20mA output, open collector output, and communications separately from the power line and power supply leads. Do not wire these outputs in the same conduit as the power line and power supply leads. Doing so might cause malfunction.
- Install a switch for shutting of main power to the device within reach of the person operating the device.
- The common mode voltage between output and Ground is less than 30r.m.s., 42.4V at peak or 60Vdc, excluding power supply and relay contact output.

■ Mounting

● Installation site

Avoid mounting the CMG in the following locations:

1. Locations whose operating temperature falls below -10°C and rises above 60°C
2. Locations whose operating humidity exceeds 90%RH
3. Locations subject to sudden changes in temperature and condensation
4. Locations subject to corrosive gases and flammable gases
5. Locations where there are lots of conductive substances (e.g. dust, salt or iron dust) or organic solvents
6. Locations subject to vibration or shock
7. Locations subject to direct sunlight
8. Locations splashed by water or rain directly
9. Locations subject to splashing by fluids (e.g. oil, chemicals.)
10. Locations where strong magnetic or electrical fields are generated

● Gas flow

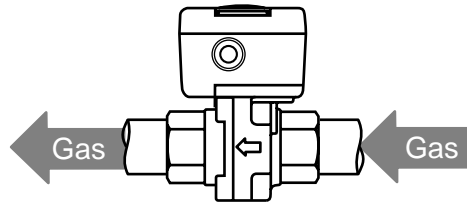

! Handling Precautions

Make sure that the gas flows into the device in the direction indicated by the FLOW arrow on the side of the flow path. Otherwise, the flowrate cannot be measured correctly.

● Mounting position

⚠ CAUTION

⊘ Do not mount so that the display is facing down.
Doing so might cause error or trouble.

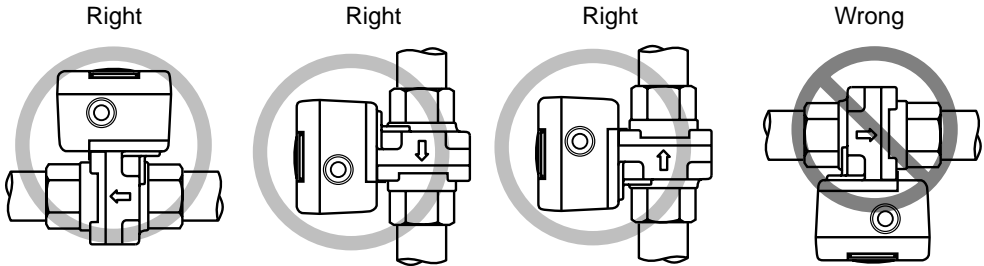

⚠ **Handling Precautions**

The length of the required direct pipe connection varies according to the model No.
For details, see Chapter 7. SPECIFICATIONS.

● Screw connection

● **Coating sealant**

Coat with an appropriate amount of sealant. Do not coat the top two threads of the screw.
Remove any dirt, burrs or piping cutting oil from inside the pipes.

⚠ **Handling Precautions**

Do not overapply sealant. Allowing entry of dirt, burrs or piping cutting oil inside the pipes might cause error.

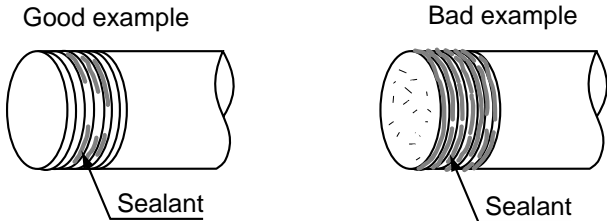

● **Connecting pipes**

Connect pipes while gripping the hexagonal section of the pipe connection port in the body with a spanner or wrench.

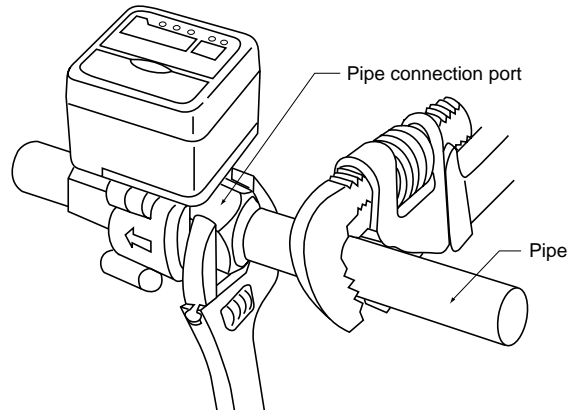

❗ **Handling Precautions**

- Do not grip the display or sensor/terminal section. Doing so might damage the body or cause leakage.
- Do not tighten the pipe at a torque that exceeds the maximum tightening torque.

Model No.	Max. Tightening Torque
CMG150	50N•m
CMG250	125N•m
CMG400	200N•m
CMG500	250N•m

● **Flange connection**

● **Gasket**

A gasket is required for connecting the flange.

The following table shows the internal diameter dimensions of the gasket.

Pipe Size (mm)	Internal Dimensions (mm)
40	37 ± 1
50	49 ± 1

❗ **Handling Precautions**

- If the gasket inner diameter is too small, the flow speed distribution may be disturbed and adversely influence accuracy.
- If the gasket inner diameter is too large, leakage may occur.
- Align the inner diameters of the piping and the flowmeter, and attach so that the gasket does not protrude into the inside of the piping. Doing so might result in leakage.

● **Flange Shape**

Use a flange that ensures a large contact area with the gasket.

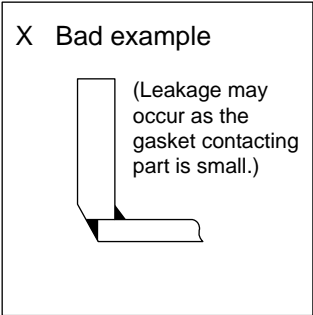
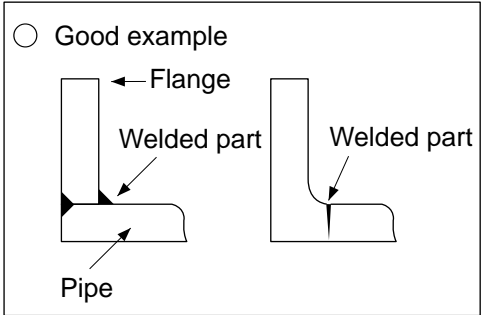

● **Mounting**

The figure below shows how to actually mount the flowmeter. Before installing the flowmeter, be sure to flush the piping to remove any foreign objects inside.

! **Handling Precautions**

Do not flush the piping with the flowmeter attached. Doing so might cause foreign objects to enter the flowmeter and cause error.

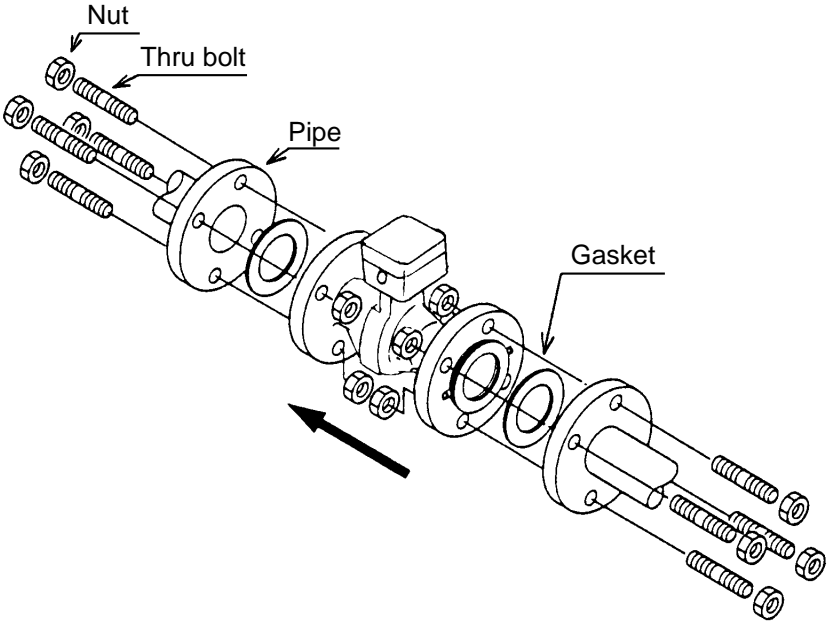

Tighten according to the torque in the following table:

Aperture/Flange Rating		Torque (N•m)
40mm	JIS10K	22 to 32
50mm	JIS10K	24 to 34

! Handling Precautions

- Tighten bolts so that they are uniformly tightened. If leakage does not stop after tightening bolts, gradually tighten the bolts more a little at a time.
- Tighten bolts within the specified tightening torque. Otherwise, the bolts may be damaged.
- Do not mount as shown in the following figure. Doing so might cause leakage.

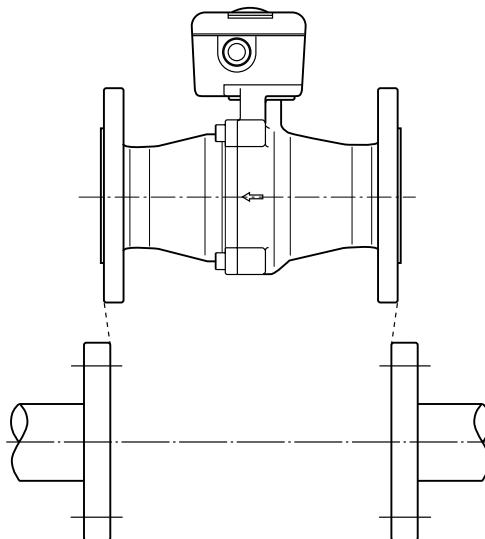

- Do not exert unnecessary force on the narrow section between flange surfaces. Doing so might damage the device.

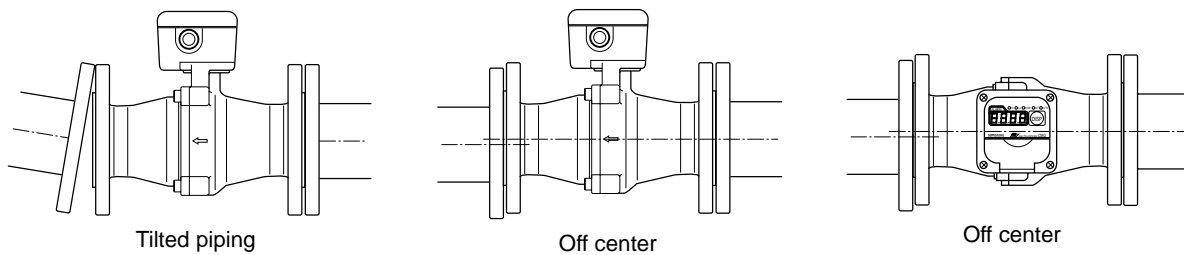

■ Wiring

⚠ CAUTION



Prevent the load connected to the output terminal from exceeding the rating indicated in the specifications.
Failure to do so might cause damage.



Be sure to check that the wiring is correct before you turn the power ON.
Incorrect wiring might cause damage or malfunction.

● **Removing the operation panel/display**

Item to prepare: Phillips screwdriver

- (1) Loosen the four screws on the operation panel/display using a Phillips screwdriver.
- (2) Lightly lift up the operation panel/display, and disconnect the power lead connectors from the operation panel/display.

● **Wiring 24Vdc power supply model**

The following shows wiring of the 24Vdc power supply model and signal names.

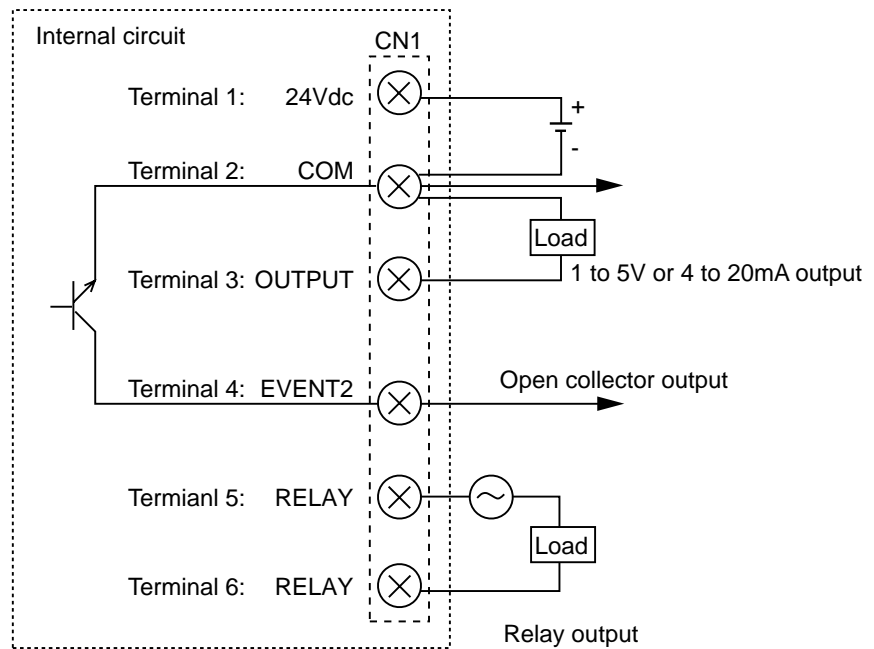

Terminal No.	Signal Name	Description
1	24Vdc	Power supply
2	COM	Common
3	OUTPUT	Analog output 1 to 5Vdc or 4 to 20mA
4	EVENT2	Event output 2 NPN open collector, integration pulse
5	RELAY	Event Output 1 Contact output
6	RELAY	Event Output 1 Contact output

● **Wiring AC power supply model**

The following shows wiring of the AC power supply model and signal names.

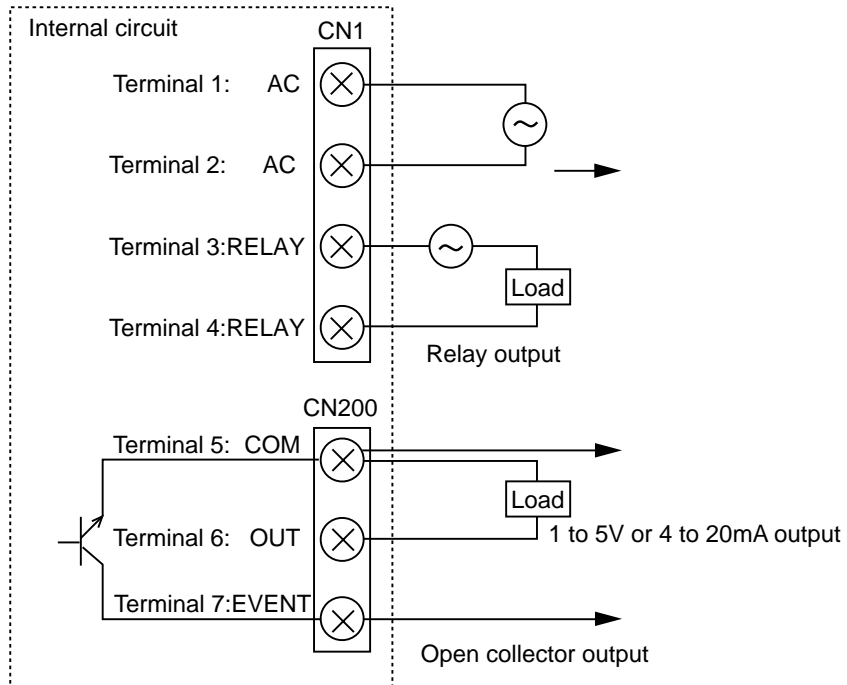

Terminal No.	Signal Name	Description
1	AC	Power supply
2	AC	Power supply
3	RELAY	Event Output 1 Contact output
4	RELAY	Event Output 1 Contact output
5	COM	Common
6	OUT	Analog output 1 to 5Vdc or 4 to 20mA
7	EVENT	Event output 2 NPN open collector, integration pulse

! Handling Precautions

- Use crimped terminal lugs that enable a reliable connection for firmly connecting to terminals.
- Use crimped terminal lugs that are compatible with M3.5 screws.
- Limit the terminal screw tightening torque to 0.8N•m.
- Use JIS C 3401 control cable (CVV, etc.) of maximum outer diameter 2.2mm for wiring.
- If waterproofing is required, be sure to use the seal connector (Yamatake model No.: PA4-N2, PA4-N4 or equivalent product) for reliable sealing.
- When wiring to terminal 2 (COM) on a 24Vdc power supply type, wire the analog output lead (COM) separately from the power lead (COM). Otherwise, a voltage drop caused by the power current may influence the accuracy of analog output.

● Mounting the operation panel/display

! Handling Precautions

The maximum screw tightening torque is 1.0N•m. IP54 sealability might be impaired if screws are tightened too tightly resulting in too loose tightening.

On this device, the operation panel/display can be rotated up to $\pm 180^\circ$ to an easy-to-view position depending on the device's mounting position.

Follow the procedure below to mount the operation panel/display:

- (1) Connect the connectors of the leads from the operation panel/display to the sensor/terminal section.
- (2) Align the display on the operation panel/display to the most easily visible direction.
- (3) Fasten the operation panel/display onto the sensor/terminal section with screws.

! Handling Precautions

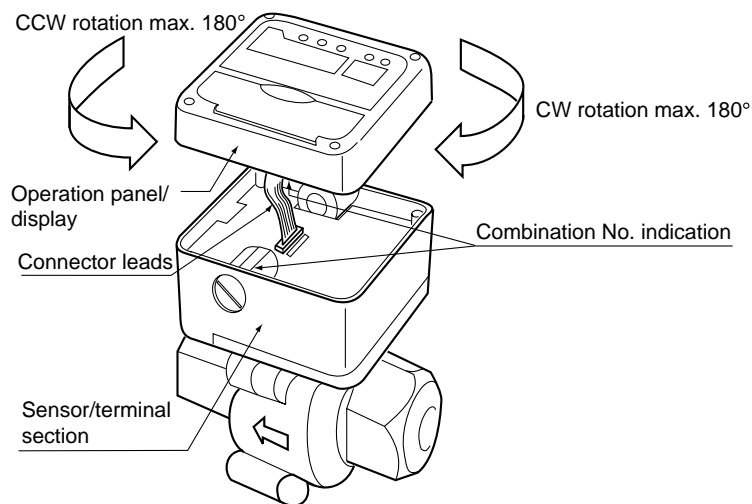

- House the leads connecting the sensor/terminal section and the operation panel/display from being unnecessarily twisted or nipped. Align the leads matched to the sensor/terminal section.
- Prevent the leads connecting the sensor/terminal section and the operation panel/display from being damaged.
- Do not rotate the operation panel/display beyond 180° to the left or right. This section may be rotated to the left or right if it is mounted with the top and bottom reversed.
- Use the operation panel/display and sensor/terminal section with the same combination of combination Nos.

Combination Nos. differ from device to device as each device is adjusted individually. If different combination Nos. are combined, accuracy can no longer be guaranteed. The combination Nos. are each displayed on the operation panel/display and sensor/terminal section.

Chapter 4. OPERATION

⚠ CAUTION



Do not operate the keys with a propelling pencil, screwdriver or other sharp-tipped object. Doing so might damage the keys.

■ Displaying the flowrate

The following values can be switched and displayed on the 4-digit, 7-segment LED on the display:

1. Instantaneous flowrate
2. Integrated flowrate

The following shows the operation flow for displaying the flowrate:

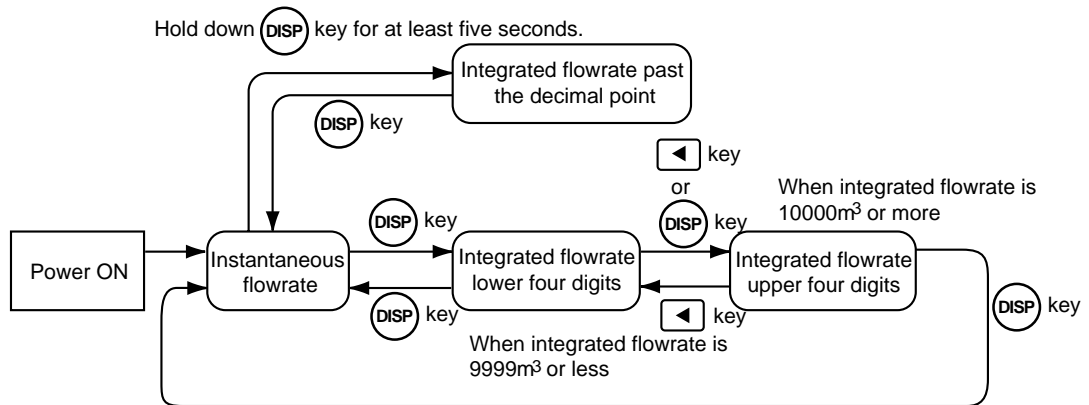

● Displaying the instantaneous flowrate and integrated flowrate

When the power is turned ON, the m^3/h indicator lights to indicate the instantaneous flowrate.

To display the integrated flowrate, press the **DISP** key.

▶ The m^3 indicator lights to indicate the integrated flowrate.

The display is a 4-digit display. However, the integrated flowrate is displayed as eight digits, divided into upper four digits and lower four digits. In all, the integrated flowrate can be displayed up to **99999999**.

While the lower four digits are displayed, the decimal point lights to the right of the lowermost digit.

When the integrated flowrate is **9999** m^3 or less, pressing the **DISP** key again returns the display to the instantaneous flowrate display.

When the integrated flowrate is **10000** m^3 or more, pressing the **DISP** key displays the upper four digits of the integrated flowrate.

You can also alternately display the upper four digits and lower four digits by the **←** key or **←** key, respectively.

For example, if we assume that the initial reading is **1 234** and the 2nd reading is **--56**, then the integrated flowrate becomes **--561 234** m^3 .

If the **DISP** key is held down for at least five seconds when switching to the integrated flowrate display from the instantaneous flowrate display, digits past the decimal point for the integrated flowrate are displayed.

! Handling Precautions

- When the flowrate exceeds the upper limit of the measurement range, the OVER indicator blinks, and goes out after the flowrate returns to within the measurement range.
- The integrated flowrate factory setting is 0.
- The integrated flowrate indication returns to 0 after 99999999 is exceeded.
- The flowrate is integrated even if the flowrate is outside of the measurement range.
Regard integrated values as a means for grasping the overall flowrate to date.

■ Resetting alarms

Press the **RESET** key.

- ▶ The alarm indicator goes out, and the alarm output relay turns OFF.

! Handling Precautions

Alarms are also reset by turning the power OFF.

The alarm re-occurs after the alarm occurrence wait time when the flowrate exceeds the alarm setting value after the flow monitor is re-energized.

■ Resetting the integrated flowrate

Hold the **RESET** key down for at least two second while the integrated flowrate is displayed.

- ▶ The integrated value becomes 0.

! Handling Precautions

Holding down the **RESET** key for two seconds or more while an alarm has occurred merely stops the alarm; it does not reset integrated values. In this case, reset the alarm after the flowrate returned to within the preset alarm range, and then hold down the **RESET** key again for two seconds or more.

■ Displaying the total flowrate

Display the total flowrate since the device was installed.

Press the **DISP** key to display the integrated flowrate.

▶ The m³ indicator lights.

Hold down the **ENT** key for at least one second in this state.

▶ The m³ indicator goes out, and the total flowrate is displayed for five seconds. The m³ indicator then automatically lights, and the display returns to the integrated flowrate display.

Just like the integrated flowrate display, the total flowrate is displayed as eight digits, divided into upper four digits and lower four digits. In all, the integrated flowrate can be displayed up to 99999999m³.

To read the upper four digits, press the **DISP** key again within five seconds while it is displayed. You can also alternately display the upper four digits and lower four digits by the **▲** key or **▲** key, respectively.

! Handling Precautions

- The total flowrate indication returns to 0 after 99999999 is exceeded.
- Integrated flowrate and total flowrate values are held in memory even if the power is turned OFF.
On models that display values down to two digits past the decimal point, data is backed up when 1's value has changed or after one hour since the last backup.
On models that display values down to one digit past the decimal point, data is backed up when 10's value has changed or after one hour since the last backup.
Integrated values that have not been backed up are discarded when the power is turned OFF.
- Resetting of the total flowrate can be enabled or disabled in the function setup.

Chapter 5. APPLICATION OPERATION

5 - 1 Function Setup

■ Setting operation

Follow the procedure below to set functions such as alarm detection and event output assignments.

- (1) Press the **DISP** key to display the instantaneous flowrate. (The m³/h indicator lights.)
- (2) If you simultaneously hold down the **▼** and the **ENT** keys for three seconds, item No. "C-01" is displayed on the 7-segment display and the function setup mode is entered.
- (3) Press the **▲** or **▼** key to select the desired setup item No., and press the **ENT** key.
- (4) The current setting blinks on the 7-segment display. Press the **▲** or **▼** key to select the desired setting.
- (5) When you have selected the desired setting, press the **ENT** key to fix the setting. At this point, the setting is updated. (After about one second, the item No. is redisplayed.)
- (6) If you want to set up other items, return to step (3) and repeat the procedure. Otherwise, proceed to step (7).
- (7) Press the **DISP** key to exit the function setup mode. (The display returns to the instantaneous flowrate display.)

! Handling Precautions

- If you do nothing for one minute after entering the function setup mode, the display automatically returns to the instantaneous flowrate display.
- If you press the **DISP** key without pressing the **ENT** key after carrying out the operation in step (4), the setting remains at the previous value without being updated.

■ Function setup item list

Display Item	Item Description	Setup Item and Description	Factory Setting	Remarks
C-01	Key lock	0: Key lock disabled 1: All settings key-locked	0	The key lock can be disabled even while it is enabled.
C-02	Flowrate alarm detection condition selection	0: Alarm detection is not performed. 1: Only the upper limit alarm is detected. 2: Only lower limit alarm 1 is detected. 3: Upper limit alarm and lower limit alarm 1 are detected. 4: Only lower limit alarm 2 is detected. 5: Upper limit alarm and lower limit alarm 2 are detected.	0	The alarm detection flowrate is set in the parameter setup mode. Lower limit alarm 1: A flowrate less than the lower limit of the measurement range is not judged as an alarm. Lower limit alarm 2: A flowrate less than the lower limit of the measurement range is judged as an alarm.
C-03	Event output 1 (relay) function assignment	0: Not used (OFF at all times) 1: ON when upper limit alarm occurs 2: ON when lower limit alarm occurs 3: ON when upper limit alarm or lower limit alarm occurs 4: ON when integration event occurs	3	
C-04	Event output 2 (open collector) function assignment	0: Not used (OFF at all times) 1: ON when upper limit alarm occurs 2: ON when lower limit alarm occurs 3: ON when upper limit alarm or lower limit alarm occurs 4: ON when integration event occurs 5: Integration pulse output	5	This item is disabled even if set on models other than those with the open collector output option
C-05	Flowrate alarm reset method selection	0: Only reset by key switch 1: Reset by key switch or automatic reset by normal recovery of flowrate	0	
C-06	Integrated flowrate reset method selection	0: Reset is not performed. 1: Only reset by key switch 2: Only automatic reset after the integration reset delay time when the integration event occurs 3: Reset by key switch or automatic reset after the integration reset delay time when the integration event occurs	1	
C-07	Total flowrate reset method selection	0: Reset is not performed. 1: Reset is performed by key switch	0	The integration flowrate is also reset when the total flowrate is reset.
C-08	Reference temperature selection	0: 0°C 1 atmosphere reference 1: 5°C 1 atmosphere reference 2: 10°C 1 atmosphere reference 3: 15°C 1 atmosphere reference 4: 20°C 1 atmosphere reference 5: 25°C 1 atmosphere reference	0	The reference temperature of flowrate output can be switched.
C-09	Pulse rate selection	0: 0.001m ³ /1 pulse 1: 0.01m ³ /1 pulse 2: 0.1m ³ /1 pulse	1	Selection 2 becomes 0.01m ³ /pulse for displays having two digits past the decimal point. Selection 0 becomes 0.01m ³ /pulse for displays having one digit past the decimal point.

5 - 2 Parameter Setup

■ Setting operation

Follow the procedure below to set parameters such as the flowrate alarm upper and lower limit setting values and alarm detection delay times.

- (1) Press the **DISP** key to display the instantaneous flowrate. (The m³/h indicator lights.)
- (2) If you hold down the **◀** key for three seconds, item "A. HI" is displayed on the 7-segment display and the parameter setup mode is entered.
- (3) Press the **▲** or **▼** key to select the desired setup item No., and press the **ENT** key.
- (4) The current setting blinks on the 7-segment display. Press the **▲** or **▼** key to change the setting to the desired value. You can move to the digit to be changed by pressing the **◀** key.
- (5) When you have finished changing the setting, press the **ENT** key to fix the setting. At this point, the setting is updated. (After about one second, the item No. is redisplayed.)
- (6) If you want to set up other items, return to step (3) and repeat the procedure. Otherwise, proceed to step (7).
- (7) Press the **DISP** key to exit the parameter setup mode. (The display returns to the instantaneous flowrate display.)

! Handling Precautions

- If you do nothing for one minute after entering the parameter setup mode, the display automatically returns to the instantaneous flowrate display.
- If you press the **DISP** key without pressing the **ENT** key after carrying out the operation in step (4), the setting remains at the previous value without being updated.

■ Parameter setup item list

No.	Display Item	Item Description	Factory Setting	Setup Range	Remarks
1	A. HI *1	Instantaneous flowrate upper limit alarm	(Upper limit of measure range) m ³ /h(normal)	(0 to 200% of measurement upper limit) m ³ /h(normal)	Selection of alarm detection condition is required in function setup C-02.
2	A. H. Hy	Hysteresis for instantaneous flowrate upper limit alarm	(Within 2% of measurement upper limit) m ³ /h(normal)	(0 to 100% of measurement upper limit) m ³ /h(normal)	
3	A. Lo *2	Instantaneous flowrate lower limit alarm	(Lower limit of measure range) m ³ /h(normal)	(0 to 100% of measurement upper limit) m ³ /h(normal)	
4	A. L. Hy	Hysteresis for instantaneous flowrate lower limit alarm	(Within 2% of measurement upper limit) m ³ /h(normal)	(0 to 100% of measurement upper limit) m ³ /h(normal)	
5	A. dLy	Delay timing for instantaneous flowrat alarm judgement	60.0s	0.0 to 999.9s	
6	E. SP. L	Integration event setup (lower four digits)	0m ³	0 to 99,999,999m ³	Setting value valid only when selecting integration event output in either C-03 or C-04 of function setup.
7	E. SP. H	Integration event setup (upper four digits)			
8	E. C. dL	Integration reset delay time	10.0s	0.0 to 999.9s	Setting value valid only when selecting automatic reset by integration reset delay in C-06 of function setup.
9	BIAS	Instantaneous flowrate bias (PV bias)	0m ³	(-10 to +10% of measurement upper limit) m ³ /h(normal)	
10	out. H	Instantaneous flowrate output 5V (20mA) scaling	(Upper limit of measure range) m ³ /h(normal)	(0 to 200% of measurement upper limit) m ³ /h(normal)	
11	out. L	Instantaneous flowrate output 1V (4mA) scaling	0m ³	(0 to 100% of measurement upper limit) m ³ /h(normal)	
12	gAS. C	Gas composition compensation coefficient	1.000	0.600 to 1.400	

* "normal" refers to the volumetric flowrate (m³/h) after converting to 0°C, 1 atmosphere.

! Handling Precautions

- *1 Be certain to set flowrate within the upper limit display. It will not detect the alarm if setting is made above the upper limit.
- *2 When "lower limit alarm1" is selected in function setup C-02, it will not detect the alarm when the flowrate is less than the lower limit of measurement range, even if the flowrate is below the lower limit alarm setting value.

● Instantaneous flowrate upper limit alarm operation

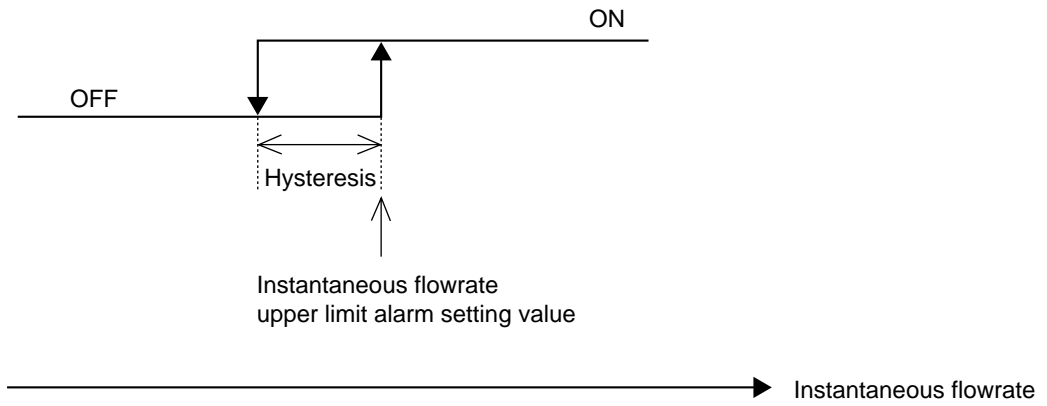

● Instantaneous flowrate lower limit alarm operation

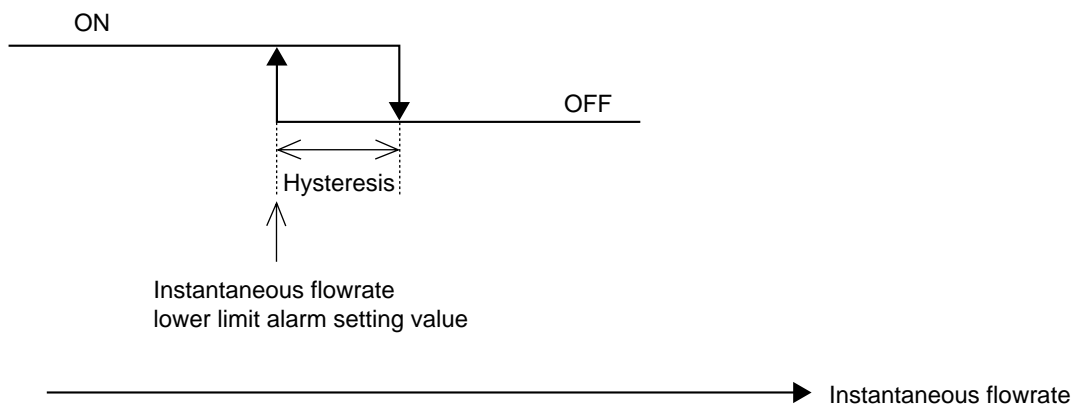

Chapter 6. MAINTENANCE AND TROUBLESHOOTING

■ Remediating trouble

When a trouble occurred, refer to the following table.

Trouble	Remedy
Nothing is displayed on the display.	<ul style="list-style-type: none"> • Make sure that the correct power voltage being applied and the polarity are correct. • Check the connectors connecting the display to the sensor/terminal section for disconnection and faulty contact. • Check the fuse to see if it is blown. Replace the fuse if blown. For details on how to replace the fuse, see the next item ■ How to replace the fuse.
<i>Err1</i> is displayed.	<ul style="list-style-type: none"> • Check the connectors connecting the display to the sensor/terminal section for disconnection and faulty contact. • If the connectors are free of abnormalities, a probable cause is a sensor error. Contact your Yamatake agent as repair by Yamatake is necessary.
<i>Err2</i> is displayed alternately with the flowrate value.	<ul style="list-style-type: none"> • A probable cause is an error in the memory adjusted for each sensor. Operation is continued with provisional data even though <i>Err2</i> is displayed. In this case, re-adjustment by Yamatake is necessary as operation is performed with the error as it is.
The display is other than 0.00 even though the instantaneous flowrate should be zero. (including a minus display)	<p>Check the shut-off valve and piping for any leaks. If the valve and piping are free of leaks, a probable cause is that the device's characteristics have changed. Contact your Yamatake agent as repair by Yamatake is necessary.</p>
A minus is displayed for the instantaneous flowrate.	<p>Make sure that the arrow marked on the flow path matches the direction of gas flow. If the directions are inverted, correct the connection directions.</p>

! Handling Precautions

Err2 (memory error) indicates that adjustment data of individual sensors in the flowmeter is lost. Accuracy cannot be guaranteed if use of the flowmeter is continued in this state.

Ask for repair.

■ How to replace the fuse

CAUTION



When touching internal parts, touch a grounded metal part to discharge static electricity from the body. Otherwise, static electricity may damage components.



Before replacing the fuse, be sure to turn the power OFF to prevent electric shock.



Be sure to use a fuse having an electrical rating of 250V, 0.5A for replacement on the 24Vdc power supply type, and a fuse having an electrical rating of 250V, 2.0A for replacement on the AC power supply type. Use of a non-rated fuse prevents the safety circuit from functioning properly.

● Items to prepare

Phillips screwdriver

Fuse: Made by Toyo Fuse

24Vdc power supply type:

Model No.: MF51NR250V0.5A (250V, 0.5A)

AC power supply type:

Model No.: MF51NR250V2.0A (250V, 2.0A)

● Replacement procedure

- (1) Loosen the four screws on the operation panel/display.
- (2) Gently lift up the operation panel/display.
- (3) Remove the fuse cover.

For details, see Chapter 2. NAMES AND FUNCTIONS OF PARTS.

- (4) Remove the fuse.
- (5) Attach the new fuse.
- (6) Attach the fuse cover.
- (7) Attach the operation panel/display at its original position on the sensor/terminal section.

Handling Precautions

When a fuse blows, check for abnormal power voltage, miswiring, or other causes of the fuse having blown.

Replacement of parts is precision work. Take sufficient care not to lose or damage removed components.

Chapter 7. SPECIFICATIONS

■ Common specifications

Item		Specifications
Applicable gas		City gas (13A), air (according to model No.), propane *1, butane *2
Rated voltage		24Vdc, 100Vac, 200Vac
Allowable voltage		24Vdc: $\pm 10\%$ of rated voltage 100Vac, 200Vac: 85% to 110%
Power consumption		24Vdc: 5.5W or less AC model: 2W or less
Flowrate display method		Flow quantity at 0°C and 1 atmospheric pressure conversion
Allowable ambient temperature		-10 to +60°C (no freezing allowed)
Storage ambient temperature		-20 to +70°C (no freezing allowed)
Allowable ambient humidity		40°C, 90%RH or less (no condensation allowed)
Instantaneous flowrate display accuracy	City gas (13A), air	Measurement range Accuracy: $\pm 4\%RD \pm 1$ digit (10 to 40°C) $\pm 6\%RD \pm 1$ digit (-10 to +60°C)
	Propane, butane	Measurement range Accuracy: $\pm 6\%RD \pm 1$ digit (10 to 40°C)
Instantaneous flowrate repeatability		$\pm 1\%RD \pm 1$ digit (20°C)
Instantaneous flowrate output	1 to 5Vdc voltage output	Output range: 0 to 200% of measurement range upper limit (scalable) Accuracy: $\pm 0.5\%FS$ Wiring distance: Within 10m External load resistance: 10k Ω or more
	4 to 20mA current output	Output range: 0 to 200% of measurement range upper limit (scalable) Accuracy: $\pm 0.5\%FS$ Load resistance: 300 Ω max.
Event output 1		1a contact (closes at event generation) Contact rating: 250Vac, 30Vdc, 5A (resistance load) Mechanical life: 20 million cycles Electrical life: 100,000 cycles
Event output 2		Output configuration: NPN open collector output Load: 30V 50mA max. When integrated pulse output is selected: Pulse width: 100ms $\pm 20\%$ For decimal point 2 digits in measurement range: Select either of 0.001m ³ /pulse or 0.01m ³ /pulse For decimal point 1 digit in measurement range: Select either of 0.01m ³ /pulse or 0.1m ³ /pulse
Pressure range		Low-pressure model: Less than 100kPa, Medium-pressure model: Less than 1.0MPa
Pressure resistance		Low-pressure model: 150kPa, Medium-pressure model: 1.5MPa
Conduit size		G 1/2 x 2 p'ces
Vibration resistance		5m/s ² or less, 10 to 60Hz, for 2 hours each in X, Y and Z directions
Shock resistance		500m/s ² or less, 3 times each in X, Y and Z directions
Voltage resistance		24Vdc power supply model Terminals 5 and 6 and flow path 1500Vac for 1min or 1800Vac for 1s AC power supply model Terminals 1 and 2 and flow path 1500Vac for 1min or 1800Vac for 1s Terminals 3 and 4 and flow path 1500Vac for 1min or 1800Vac for 1s
Insulation resistance		Between each terminals and flow path metal parts: min. 50M Ω (500Vdc)
Protection		IP54 (JIS C 0920)

*1: Propane gas composition: Propane 98%, (class B)

*2: Butane gas composition: Butane 75%, propane 25%

Individual specifications

Item		Specifications						
		CMG15	CMG25		CMG40		CMG50	
Model No.		Rc 1 1/2'		Rc 1'		Rc 1 1/2'		Rc 2'
Aperture		—		—		40A JIS 10K RF		50A JIS 10K RF
13A(N) • Air(N) m ³ /h (normal) *1	Measurement range *2	0.50 to 4.00	1.00 to 10.00	3.0 to 30.0	8.0 to 80.0	15.0 to 150.0	8.0 to 80.0	15.0 to 150.0
	Display range	0.00 to 7.00	0.00 to 16.00	0.0 to 35.0	0.0 to 100.0	0.0 to 170.0	0.0 to 100.0	0.0 to 170.0
Propane (P) m ³ /h (normal) *1	Measurement range *2	0.20 to 2.00	0.40 to 4.00	1.00 to 10.00	2.5 to 25.0	5.0 to 50.0	2.5 to 25.0	5.0 to 50.0
	Display range	0.00 to 3.00	0.00 to 6.00	0.00 to 12.00	0.0 to 30.0	0.0 to 55.0	0.0 to 30.0	0.0 to 55.0
Butane (B) m ³ /h (normal) *1	Measurement range *2	0.10 to 1.00	0.30 to 3.00	0.80 to 8.00	2.0 to 20.0	4.0 to 40.0	2.0 to 20.0	4.0 to 40.0
	Display range	0.00 to 1.50	0.00 to 4.50	0.00 to 10.00	0.0 to 25.0	0.0 to 45.0	0.0 to 25.0	0.0 to 45.0
Upstream direct pipe connection length for 90° bent pipe *3		Not required	Not required	15cm or more	10cm or more	40cm or more	10cm or more	40cm or more
Pressure loss, value of air measurement range upper limit	Screw connection	140Pa	215Pa	210Pa	500Pa	1300Pa	285Pa	550Pa
	Flange connection	—	—	—	390Pa	840Pa	250Pa	430Pa
Weight	Rc screw	Approx. 850g	Approx. 800g	Approx. 800g	Approx. 2100g	Approx. 2100g	Approx. 2000g	Approx. 2000g
	Flange	—	—	—	Approx. 9kg	Approx. 9kg	Approx. 10kg	Approx. 10kg

*1: "normal" refers to the volumetric flowrate (m³/h) after converting to 0°C, 1 atmosphere.

*2: The measurement range is the flowrate range in which instantaneous flowrate display accuracy is stipulated.

*3: Direct pipe connection lengths other than above are sometimes required depending on pipe shape.

■ External dimensions

Unit: mm

● CMG150/250

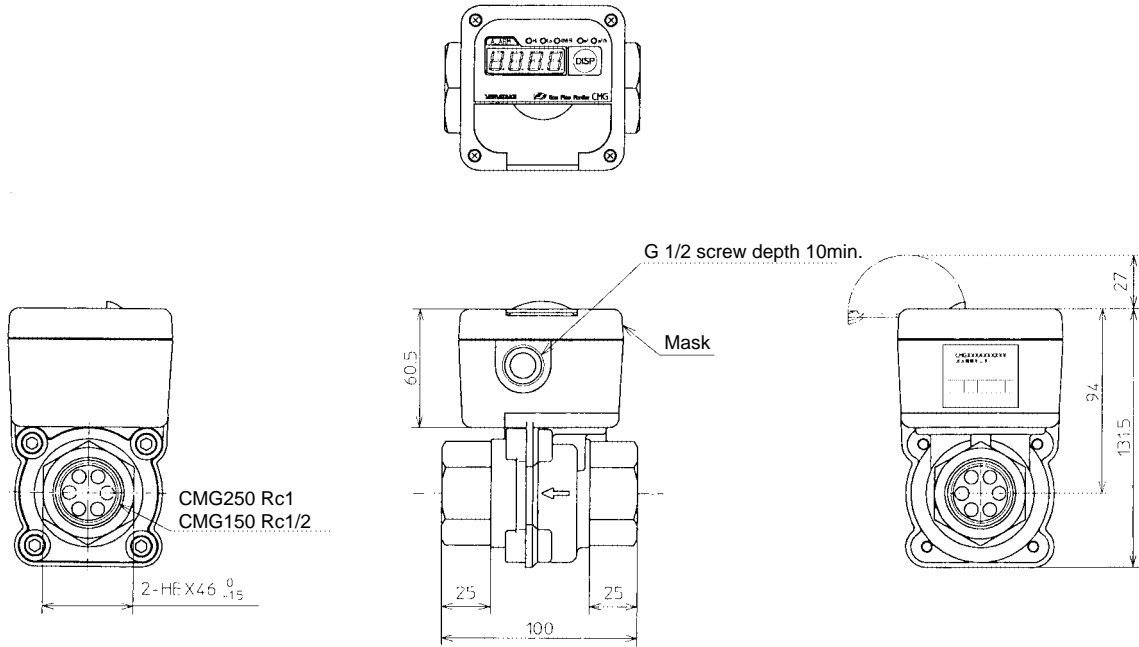

● CMG400/500

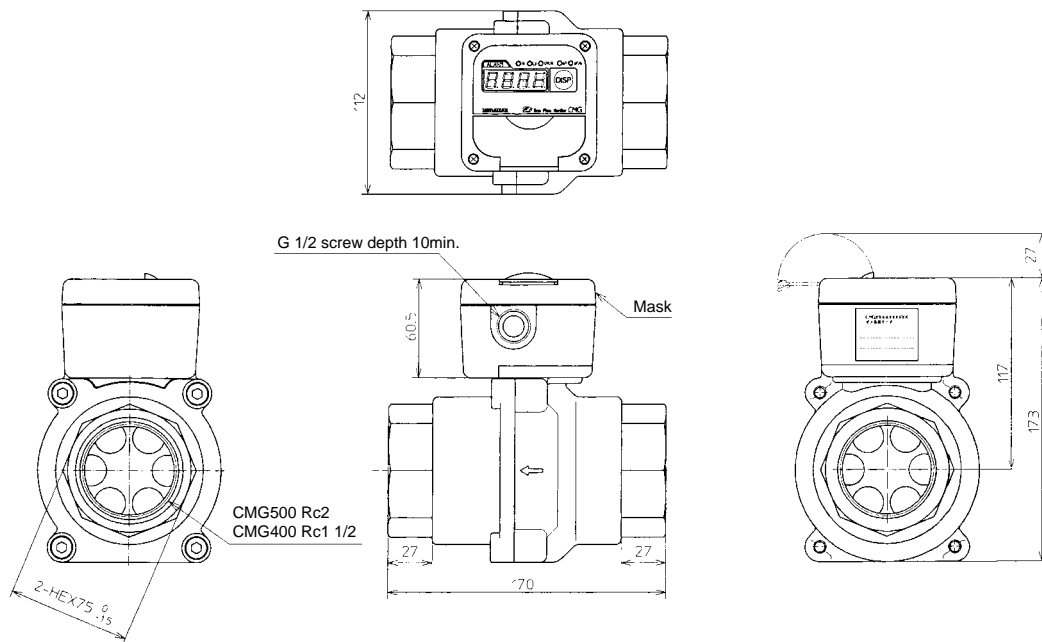

● CMG401

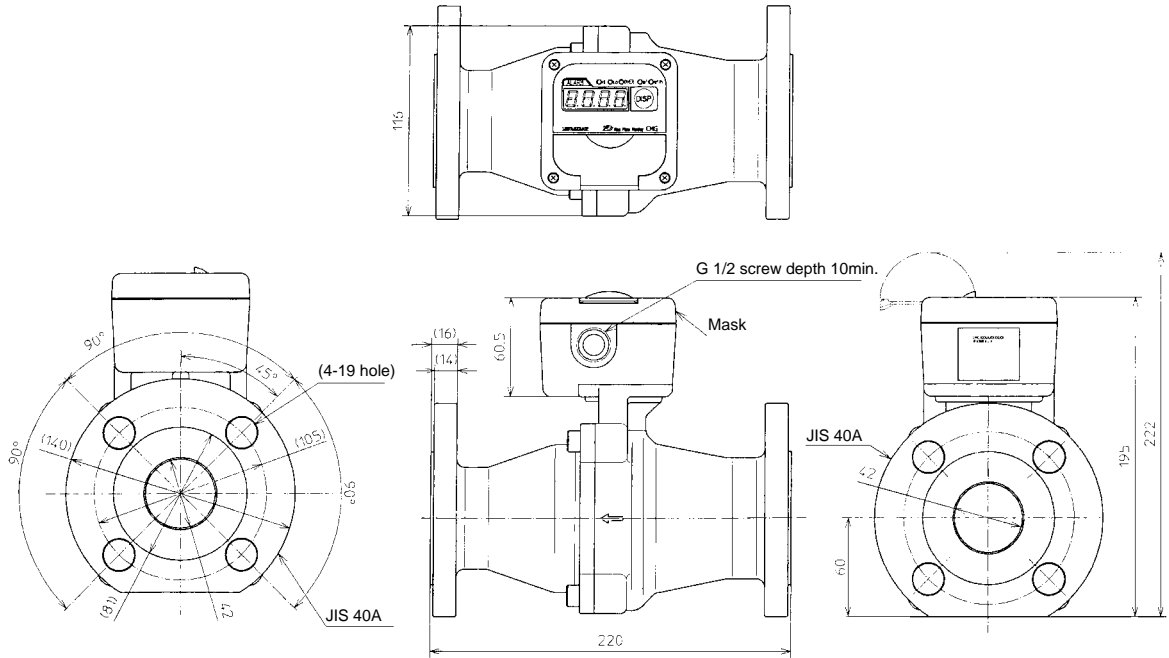

● CMG501

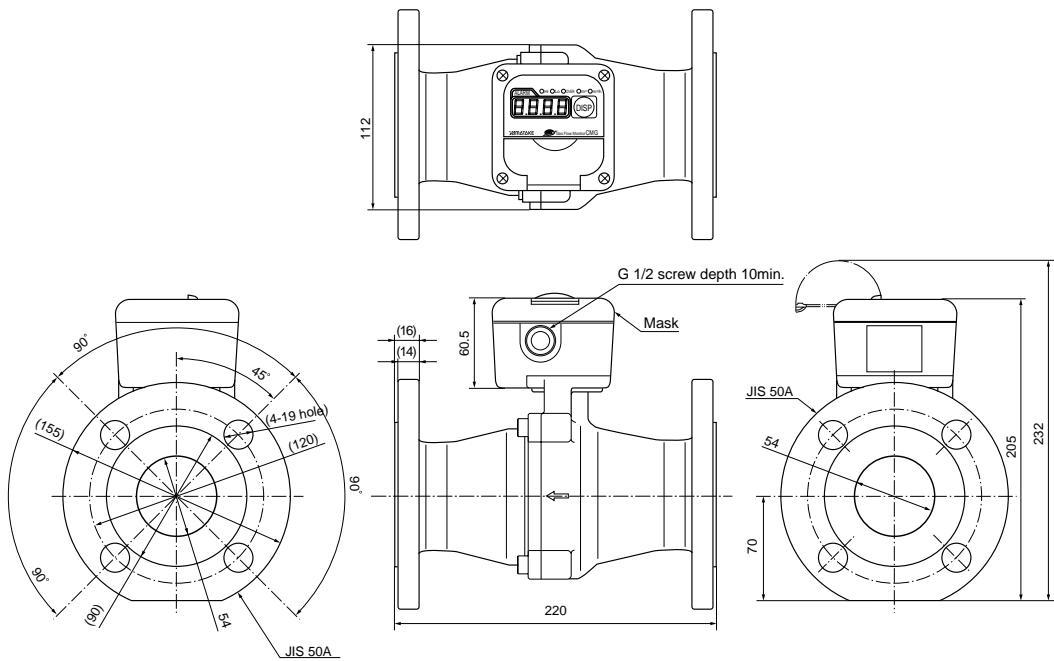

Specifications are subject to change without notice.

YAMATAKE

Yamatake Corporation

Control Product Division

Sales contact: Yamatake Corporation,
IBD Sensing and Control Department

Totate International Building

2-12-19 Shibuya Shibuya-ku Tokyo 150-8316 Japan

Phone: 81-3-3486-2380

Fax: 81-3-3486-2300

This has been printed on recycled paper.

Printed in Japan.
1st Edition: Issued in July, 2001(W)