



Gas Mass Flow Meter CMS9500/0002/0005 0020/0050/0200/0500

User's Manual



Thank you for purchasing the CMS Series.

This manual contains information for ensuring correct use of the CMS Series. It also provides necessary information for installation, maintenance, and troubleshooting.

This manual should be read by those who design and maintain devices that use the CMS Series.

Be sure to keep this manual nearby for handy reference.

Yamatake Corporation

RESTRICTIONS ON USE

This product has been designed, developed and manufactured for general-purpose application in machinery and equipment.

Accordingly, when used in applications outlined below, special care should be taken to implement a fail-safe and/or redundant design concept as well as a periodic maintenance program.

- Safety devices for plant worker protection
- Start/stop control devices for transportation and material handling machines
- Aeronautical/aerospace machines
- Control devices for nuclear reactors

Never use this product in applications where human safety may be put at risk.

REQUEST

Ensure that this User's Manual is handed over to the user before the product is used.

Copying or duplicating this User's Manual in part or in whole is forbidden. The information and specifications in this User's Manual are subject to change without notice.

Considerable effort has been made to ensure that this User's Manual is free from inaccuracies and omissions.

If you should find any inaccuracies or omissions, please contact Yamatake Corporation.

In no event is Yamatake Corporation liable to anyone for any indirect, special or consequential damages as a result of using this product.

©2001 Yamatake Corporation ALL RIGHTS RESERVED

The μ F logo is a trademark of Yamatake Corporation.

Micro Flow, CMS are trademark of Yamatake Corporation.

SAFETY PRECAUTIONS

■ About Icons

Safety precautions are for ensuring safe and correct use of this product, and for preventing injury to the operator and other people or damage to property. You must observe these safety precautions. The safety precautions described in this manual are indicated by various icons.

As the following describes the icons and their meanings, be sure to read and understand the descriptions before reading this manual:



WARNING

Warnings are indicated when mishandling this product might result in death or serious injury to the user.



CAUTION

Cautions are indicated when mishandling this product might result in minor injury to the user, or only physical damage to this product.

■ Examples

	<p>Triangles warn the user of a possible danger that may be caused by wrongful operation or misuse of this product.</p> <p>These icons graphically represent the actual danger. (The example on the left warns the user of the danger of electric shock.)</p>
	<p>White circles with a diagonal bar notify the user that specific actions are prohibited to prevent possible danger.</p> <p>These icons graphically represent the actual prohibited action. (The example on the left notifies the user that disassembly is prohibited.)</p>
	<p>Black filled-in circles instruct the user to carry out a specific obligatory action to prevent possible danger.</p> <p>These icons graphically represent the actual action to be carried out. (The example on the left instructs the user to remove the plug from the outlet.)</p>

WARNING



If this device is used for a flammable gas, mount it on the upstream side of the safety check valve. When air or oxygen gets in the piping and an explosive mixture is produced, if a sensor should make a spark due to lightning or other reason, the mixture may explode inside the piping.



Never allow gases that are within explosive limits to pass through this meter or device.
Doing so might result in explosion accidents.



If a model No. intended for use in oxygen gas has been used for other gases, never use it again for oxygen gas.
Doing so might result in a serious accident.



Do not use this device for oxygen gas when it has been purchased for applications other than for oxygen gas.
Doing so might result in a serious accident.

CAUTION



Prevent foreign matter from entering the device.
If the rust, water droplet, oil mist or dust in the piping flows into the device, measurement error might occur and result in damaging the device. If there is a possibility that any foreign matter flows into the device, provide a filter, strainer or mist trap capable of eliminating more than 0.1 μ m foreign matter at the upstream, and periodically inspect and replace the filter.



If this device is used for monitoring flowrate of the burner, consider the piping instrumentation lest the backfire damage this device.



This device is a precision instrument. Do not drop it nor subject it to shock. Doing so might damage the device.



Do not use this device outside of the operating pressure range. Also, do not subject this device to a pressure above the pressure resistance. Doing so might damage this device.



Do not peel off the pipe connector port seals until immediately before you connect the piping. Doing so might allow foreign objects to enter the connector port and cause defective operation.



When connecting piping, fasten the flange section of the pipe connector port, and turn the pipe side to connect.



When mounting the device, firmly fasten to prevent vibration.



In the case of Rc connections, take care not to coat with too much sealant. Dirt or burrs in the piping may also cause errors.

CAUTION



Before connecting pipes on Swagelok connection method and VCR connection method, check the precautions in the instruction manual provided by the connecting joint manufacturer.

When purchasing a separate connecting joint, use the following made by corresponding connection joint maker.

1/4Swagelok : Swagelok Co.,Ltd. SS-400-1-6STSC11

1/2Swagelok : Swagelok Co.,Ltd. SS-810-1-8STSC11

1/4VCR : Swagelok Co.,Ltd. SS-4-VCR-1-00032SC11

3/8VCR : Swagelok Co.,Ltd. SS-8-VCR-1-8STSC11 or equivalent product.



Carry out the following when using this device in oxygen gas:

- Piping must be carried out by an experienced engineer familiar with the handling of oxygen gas.
- Use pipes that are treated to be oil-inhibiting.
- Remove any dirt or burrs from inside the pipes before you attach this device.
- Attach a filter at the upstream of this device.



Do not hold a resin cover portion at the time of carrying or piping this device.

Doing so might damage the cover, or dropping the device due to slipping might result in getting hurt.



Do not install PBT resin models in the direct sunlight.

Doing so might damage the device.



Do not connect piping on PBT resin models in such a way that large force will be applied to the product.

Doing so might damage the device.



Mount this device horizontally. Do not mount so that the top surface is facing down.

Doing so might cause error or trouble.

If this device is mounted vertically, it may drift causing an error while the flowrate is zero.



When using a relay as the contact for integrated count reset input, use a relay (gold contact type) for trace currents.

Otherwise, detective, contact may cause the device to malfunction.



When wiring, take care not to tug the display.

The components inside might become damaged.



Be sure to check that the wiring is correct before you turn the power ON. Incorrect wiring might cause damage or malfunction.



Do not operate the keys with a propelling pencil or sharp-tipped object. Doing so might cause faulty operation.



Do not remove the case and disassemble pipe connections.

Doing so might cause malfunction.

Organization of This User's Manual

This manual is organized as follows:

Chapter 1. INTRODUCTION

This chapter briefly describes this device, its features and the model selection guide.

Chapter 2. NAMES AND FUNCTIONS OF PARTS

This chapter describes the NAMES AND FUNCTIONS OF PARTS on this device.

Chapter 3. MOUNTING AND WIRING

This chapter describes installation, mounting, wiring and initial settings on this device.

Chapter 4. METHOD OF OPERATION (Models with Display Meter)

This chapter describes how to set the functions and parameters on this device.

Chapter 5. TROUBLESHOOTING

This chapter describes how to investigate and remedy trouble that may occur during operation of this device.

Chapter 6. SPECIFICATIONS

This chapter describes the specifications, external dimensions and pressure loss of this device.

Contents

SAFETY PRECAUTIONS

Organization of This User's Manual

Conventions Used in This Manual

Chapter 1. INTRODUCTION

- Introduction..... 1
- Features 1
- List of applicable flowrates 1
- Model selection guide..... 2

Chapter 2. NAMES AND FUNCTIONS OF PARTS

Chapter 3. MOUNTING AND WIRING

- Mounting..... 8
- Wiring..... 11

Chapter 4. METHOD OF OPERATION (Models with Display Meter)

- Function setup..... 15
- Parameter setup..... 21
- State transition 25
- Integration 26
- Resetting the integrated value and reverse-integrated value 26
- What is "Event standby?" 26
- Event ON delay 26

Chapter 5. TROUBLESHOOTING





- Remediating trouble 27

Chapter 6. SPECIFICATIONS

- General specifications..... 28
- External dimensions..... 36
- Pressure loss..... 43

Conventions Used in This Manual

The following conventions are used in this manual:

-  **Handling Precautions** : Handling Precautions indicate items that the user should pay attention to when handling the CMS Series.
-  **Note** : Notes indicate useful information that the user might benefit by knowing.
-  : This indicates the item or page that the user is requested to refer to.
- (1), (2), (3) : The numbers with the parenthesis indicate steps in a sequence or indicate corresponding parts in an explanation.
- 03*, *04* : This indicates 7-segment indication on the setup display.
-  key : This indicates a key on the setup display.

Chapter 1. INTRODUCTION

■ Introduction

The CMS9500/0002/0005/0020/0050/0200/0500 Gas mass flow meter uses μ F (Micro Flow) sensor in the sensing section. The μ F sensor is a thermal flow speed sensor made using proprietary technology. Integrating this ultra-minute flow speed sensor with high-grade channel design technology has achieved high accuracy and wide rangeability.

■ Features

- Incorporates a μ F sensor made possible by silicon micro-machining technology and thin-film forming technology.
One side of the μ F sensor is a mere 1.7mm, and at a thickness of 0.5mm, this thermal flow speed sensor exhibits high sensitivity and response.
- As this device is a mass flow meter, it is not influenced by temperature nor pressure.
- Implements a high accuracy of $\pm 3\%$ RD* (this value varies depending on the model) and a high-range ability of 100:1.

Model	Range of measurement
CMS9500	5 to 500 mL/min (standard)
CMS0002	0.02 to 2 L/min (standard)
CMS0005	0.05 to 5 L/min (standard)
CMS0020	0.2 to 20 L/min (standard)
CMS0050	0.5 to 50 L/min (standard)
CMS0200	2 to 200 L/min (standard)
CMS0500	5 to 500 L/min (standard)

- Instantaneous flowrate values can be displayed remotely by combining with a multi-channel indicator (CMW100A101, sold separately).
- Models with display meter are provided with extensive functions to suit a wide range of applications: analog output, event output, integrating/reverse-integrating display, output scaling, gas type selection, integrated pulse output, external contact input (integrating reset input), flowrate data serial output.
- Straight pipe sections are not required before and after this device.

Note

* "RD" (Reading) indicates the accuracy of the read value. The accuracy varies depending on the model. For details, see "Chapter 6. SPECIFICATIONS".

■ List of applicable flowrates

Flowrate range	Resin model	SUS model	SUS316 model
9500		○	○
0002		○	○
0005		○	○
0020	○*	○*	○
0050	○*	○*	○
0200		○*	○
0500		○	○

*: A model without display available.

■ Model selection guide

The following shows the model Nos. for this flow meter:

● Resin model without display

Basic model No.	Flowrate range	Model type	Material	Connection method	Gas type	Out put	Optional function				Appended No.	Description
							1	2	3	4		
CMS												Gas Mass Flow Meter
	0020											Standard flowrate range 0 to 20L/min (standard) *1
	0050											Standard flowrate range 0 to 50L/min (standard) *1
		A										Model without display + Instantaneous flowrate output
			P									PBT resin
				R								Rc1/4
					N							Air/Nitrogen
					C							Carbon dioxide (CO ₂)
						0						Analog output 0 to 5Vdc
							0					Without optional function
								0				Without optional function
									0			Additional treatment not supported
										0		Without options
										D		Inspection Certificate provided
										Y		Complying with the traceability certification
											0	Product version

● Resin model with display

Basic model No.	Flowrate range	Model type	Material	Connection method	Gas type	Out put	Optional function				Appended No.	Description
							1	2	3	4		
CMS												Gas Mass Flow Meter
	0020											Standard flowrate range 0 to 20L/min (standard) *1
	0050											Standard flowrate range 0 to 50L/min (standard) *1
		B										Model with display/Instantaneous flowrate output + Event output + Integration pulse output + Integration reset input
			P									PBT resin
				R								Rc1/4
					N							Air/Nitrogen (Can be set and changed to carbon dioxide.)
						0						Analog output 0 to 5Vdc
							0					Without optional function
								0				Without optional function
									0			Additional treatment not supported
										0		Without options
										D		Inspection Certificate provided
										Y		Complying with the traceability certification
											0	Product version

● SUS model without display

Basic model No.	Flowrate range	Model type	Material	Connection method	Gas type	Out put	Optional function				Appended No.	Description
							1	2	3	4		
CMS												Gas Mass Flow Meter
	0020											Standard flowrate range 0 to 20L/min (standard) *1
	0050											Standard flowrate range 0 to 50L/min (standard) *1
	0200											Standard flowrate range 0 to 200L/min (standard) *1
		A										Model without display + Instantaneous flowrate output
			P									SUS (For details, refer to the specifications.)
				R								Rc1/2 (CMS0200) Rc1/4 (CMS0020/0050)
					N							Air/Nitrogen
					C							Carbon dioxide (CO ₂)
					S							Oxygen *2
					G							City gas 13A (LNG) *3
					L							Propane 100%
						0						Analog output 0 to 5Vdc
							0					Without optional function
								0				Without optional function
									0			Additional treatment not supported
										1		Gas-contacting parts treated to be oil-inhibiting
											0	Without options
											D	Inspection Certificate provided
											Y	Complying with the traceability certification
											0	Product version

● SUS model with display

Basic model No.	Flowrate range	Model type	Material	Connection method	Gas type	Out put	Optional function				Appended No.	Description
							1	2	3	4		
CMS												Gas Mass Flow Meter
	9500											Standard flowrate range 0 to 500mL/min (standard) *1
	0002											Standard flowrate range 0 to 2L/min (standard) *1
	0005											Standard flowrate range 0 to 5L/min (standard) *1
	0020											Standard flowrate range 0 to 20L/min (standard) *1
	0050											Standard flowrate range 0 to 50L/min (standard) *1
	0200											Standard flowrate range 0 to 200L/min (standard) *1
	0500											Standard flowrate range 0 to 500L/min (standard) *1
		B										Model with display + Instantaneous flowrate output + Event output + Integration pulse output + Integration reset input
			S									SUS (For details, refer to the specifications.)
				R								Rc1/2 (CMS0200/0500) Rc1/4 (CMS9500/0002/0005/0020/0050)
					N							Standard supported gas *4
					S							Oxygen *2
						0						Analog output 0 to 5Vdc
							0					Without optional function
								0				Without optional function
									0			Additional treatment not supported
										1		Gas-contacting parts treated to be oil-inhibiting
											0	Without options
											D	Inspection Certificate provided
											Y	Complying with the traceability certification
											0	Product version

● SUS 316 model

Basic model No.	Flowrate range	Model type	Material	Connection method	Gas type	Out put	Optional function				Appended No.	Description	
							1	2	3	4			
CMS												Gas Mass Flow Meter	
	9500											Standard flowrate range 0 to 500mL/min (standard) *1 *4	
	0002											Standard flowrate range 0 to 2L/min (standard) *1 *4	
	0005											Standard flowrate range 0 to 5L/min (standard) *1 *4	
	0020											Standard flowrate range 0 to 20L/min (standard) *1 *4	
	0050											Standard flowrate range 0 to 50L/min (standard) *1 *4	
	0200											Standard flowrate range 0 to 200L/min (standard) *1 *4	
	0500											Standard flowrate range 0 to 500L/min (standard) *1 *4	
		B										Model with display	
			T									Stainless SUS316	
				U								UNF connection CMS200/500: 3/4-16 UNF CMS9500/0002/0005/0020/0050: 9/16-18 UNF	
				T								Rc fitting connection CMS200/500: 1/2 Rc CMS9500/0002/0005/0020/0050: 1/4 Rc	
				S								Swl connection CMS0200/0500: 1/2 Swagelok CMS9500/0002/0005/0020/0050: 1/4 Swagelok	
				V								VCR connection CMS200/500: 3/8VCR or equivalent CMS9500/0002/0005/0020/0050: 1/4 VCR	
					N							Air/Nitrogen (Setting can be changed to standard supported gases *4)	
					S							Oxygen *2	
						0						Output 0 to 5Vdc	
							0					Without optional function	
								0				Without optional function	
									0			Without oil-inhibited treatment	
										1		Gas-contacting parts treated to be oil-inhibiting	
											0	Without optional function	
											D	Inspection Certificate provided	
											Y	Complying with the traceability certification	
												0	Product version

*1: "standard" refers to a flowrate after conversion to 20°C, 1atm.

*2: When oxygen (gas type: S) is selected, make sure to specify "1: Gas-contacting parts treated to be oil-inhibiting" of the optional function. Be aware that oxygen cannot be used in the model numbers other than that for oxygen.

*3: The conversion factor of city gas 13A is set to the gas (methane CH4 88%) produced from LNG. When the gas composition of 13A is different from usual 13A gas, contact Yamatake.

*4: The factory default setting is air/nitrogen.

You can change it to any of the gas types shown below. When you change the gas type, sometimes the flowrate range changes. Consequently, when selecting a gas type, make sure to check the "maximum measurement flowrate for each gas type" in the specifications of the corresponding model.

Applicable gas types: Air/nitrogen, argon, carbon dioxide (CO2), oxygen (gas type: S only), city gas 13A (a gas produced from LNG, of which 88% is methane), methane 100%, propane 100%, butane

Chapter 2. NAMES AND FUNCTIONS OF PARTS

The following describes the names and functions of parts:



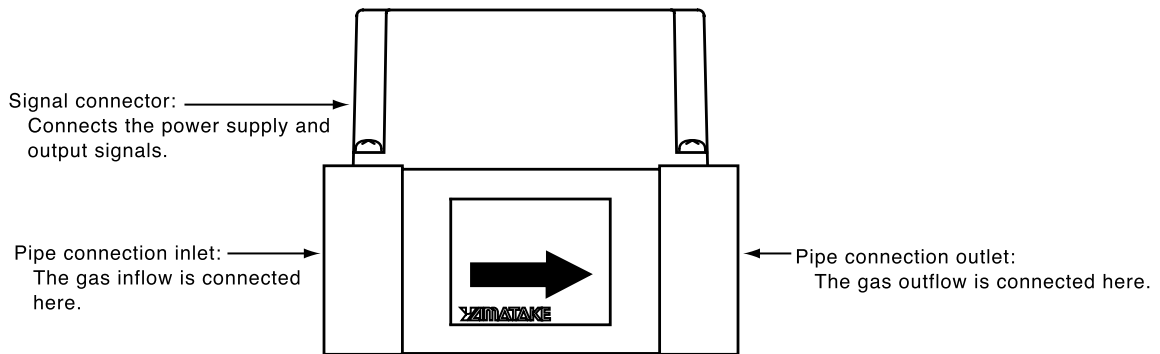
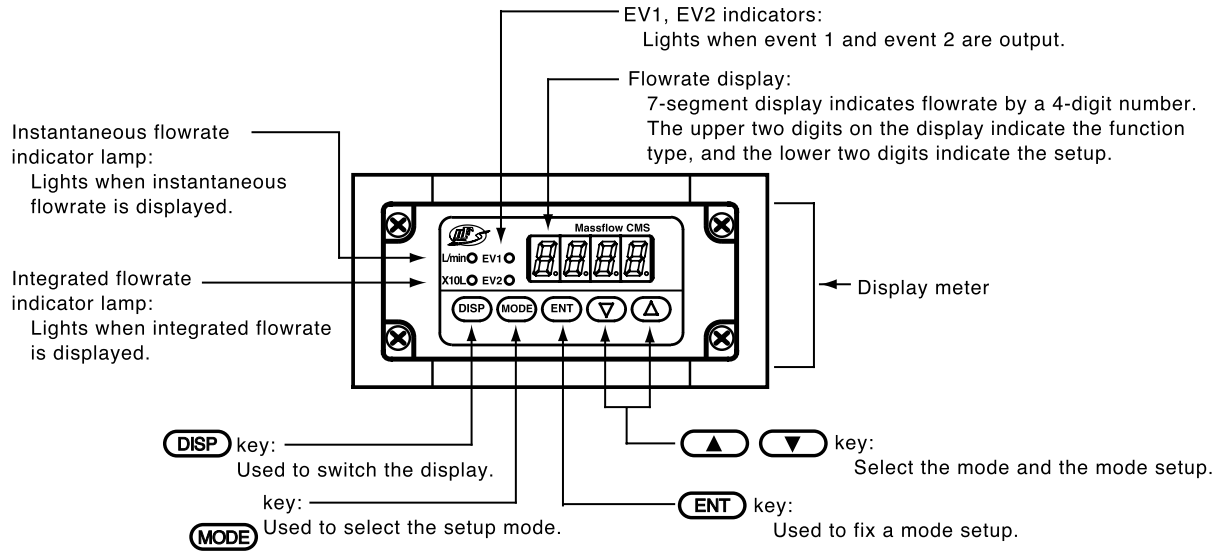

The diagram below shows a model with display meter.











MEMO

Chapter 3. MOUNTING AND WIRING

WARNING

-  If this device is used for a flammable gas, mount it on the upstream side of the safety check valve. When air or oxygen gets in the piping and an explosive mixture is produced, if a sensor should make a spark due to lightning or other reason, the mixture may explode inside the piping.
-  Never allow gases that are within explosive limits to pass through this meter or device.
Doing so might result in explosion accidents.
-  If a model No. intended for use in oxygen gas has been used for other gases, never use it again for oxygen gas.
Doing so might result in a serious accident.
-  Do not use this device for oxygen gas when it has been purchased for applications other than for oxygen gas.
Doing so might result in a serious accident.

CAUTION

-  Prevent foreign matter from entering the device.
If the rust, water droplet, oil mist or dust in the piping flows into the device, measurement error might occur and result in damaging the device.
If there is a possibility that any foreign matter flows into the device, provide a filter, strainer or mist trap capable of eliminating more than 0.1 μ m foreign matter at the upstream, and periodically inspect and replace the filter.
-  If this device is used for monitoring flowrate of the burner, consider the piping instrumentation lest the backfire damage this device.
-  Do not use this device outside of the operating pressure range. Also, do not subject this device to a pressure above the pressure resistance.
Doing so might damage this device.
-  Do not peel off the pipe connector port seals until immediately before you connect the piping. Doing so might allow foreign objects to enter the connector port and cause defective operation.
-  When connecting piping, fasten the flange section of the pipe connector port, and turn the pipe side to connect.
-  When mounting the device, firmly fasten to prevent vibration.
-  In the case of Rc connections, take care not to coat with too much sealant. Dirt or burrs in the piping may also cause errors.
-  Before connecting pipes on Swagelok connection method and VCR connection method, check the precautions in the instruction manual provided by the connecting joint manufacturer.
When purchasing a separate connecting joint, use the following made by corresponding connection joint maker.
1/4Swagelok : Swagelok Co.,Ltd. SS-400-1-6STSC11
1/2Swagelok : Swagelok Co.,Ltd. SS-810-1-8STSC11
1/4VCR : Swagelok Co.,Ltd. SS-4-VCR-1-00032SC11
3/8VCR : Swagelok Co.,Ltd. SS-8-VCR-1-8STSC11 or equivalent product.

⚠ CAUTION



Carry out the following when using this device in oxygen gas:

- Piping must be carried out by an experienced engineer familiar with the handling of oxygen gas.
- Use pipes that are treated to be oil-inhibiting.
- Remove any dirt or burrs from inside the pipes before you attach this device.
- Attach a filter at the upstream of this device.



Do not hold a resin cover portion at the time of carrying or piping this device. Doing so might damage the cover, or dropping the device due to slipping might result in getting hurt.



Do not install PBT resin models in the direct sunlight. Doing so might damage the device.



Do not connect piping on PBT resin models in such a way that large force will be applied to the product. Doing so might damage the device.

■ **Mounting**

● **Installation site**

Avoid mounting this device in the following locations:

1. Locations whose operating temperature falls below 0°C and rises above 50°C
2. Locations whose operating humidity exceeds 90%RH
3. Locations subject to sudden changes in temperature and condensation
4. Locations subject to corrosive gases and flammable gases
5. Locations where there are lots of conductive substances (e.g. dust, salt or iron dust), water droplets, oil mist or organic solvents
6. Locations subject to vibration or shock
7. Locations subject to direct sunlight
8. Locations splashed by water or rain
9. Locations subject to splashing by fluids (e.g. oil, chemicals.)
10. Locations where strong magnetic or electrical fields are generated

● **Rc connection**

- Coating sealant

Coat with an appropriate amount of sealant. Do not coat the top two threads of the screw. Remove any dirt or burrs from inside the pipes.

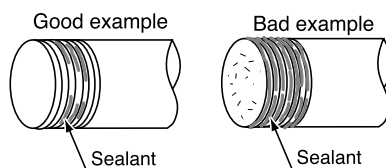

- **Connecting Pipes**
Connect pipes while gripping the hexagonal section of the pipe connection port in the case of resin models (or, flange on SUS models) with a spanner or wrench.

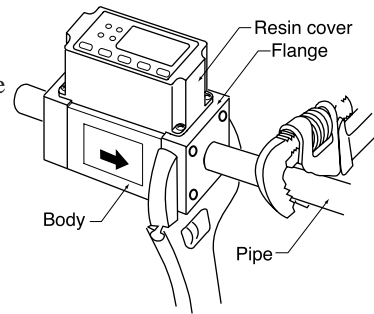

● UNF connection

- **Connecting Joints**
Connect joints while gripping the hexagonal section of the connection port pipe in the case of resin models (or, flange on SUS models) with a spanner or wrench.

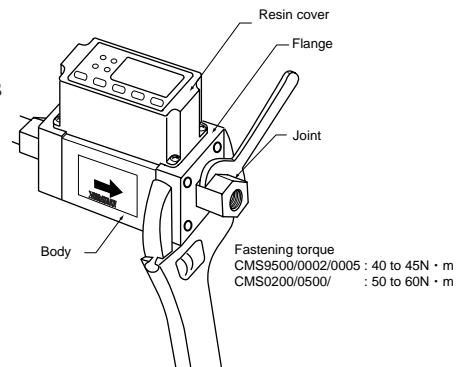

! **Handling Precautions**

- Do not grip and turn the body. Doing so might damage the body or cause leakage.
- When connecting pipes, do not grasp the resin cover. Doing so might damage the cover.
- Compliant with the specified fastening torque.

Fastening torque
CMS9500/0002/0005 : 40 to 45N · m
CMS0200/0500/ : 50 to 60N · m

● Gas flow

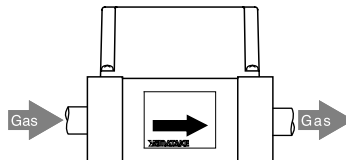

! **Handling Precautions**

When feeding gas into the meter, make it flow following the arrow on the side of the channel. If gas is fed in the opposite direction, the gas flow cannot be measured accurately.

● Mounting the body

CAUTION



Mount this device horizontally. Do not mount so that the top surface is facing down. Doing so might cause error or trouble. If this device is mounted vertically, it may drift causing an error while the flowrate is zero.

- **Mounting Position**

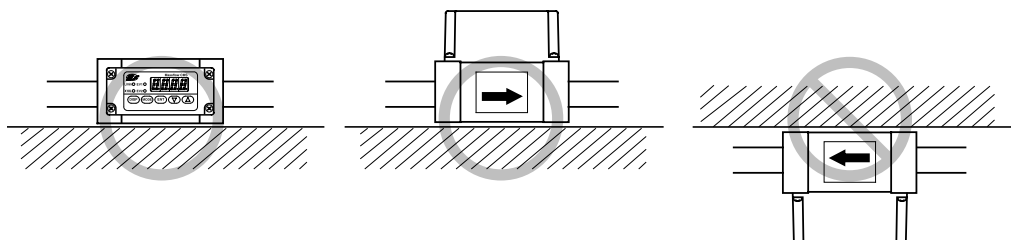

- Mounting

There are two ways of mounting the body:

1. Fasten the body with two or four screws (the number of screws depends on the model No.) from the rear side using the mounting screw holes on the bottom of the device.

Hole dimensions when mounted directly

• Resin model CMS0020/0050 unit : mm

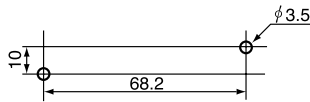

CMS9500/0002/0005/0020/0050

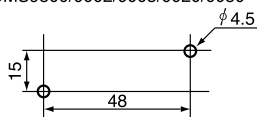

CMS0200

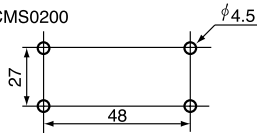

CMS0500

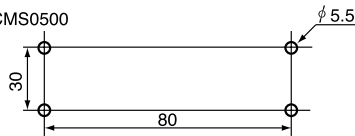

2. Attach the special mounting bracket (option), and fasten the mounting bracket from the front using four screws.

Mounting bracket Model No.:

for CMS9500/0002/0005/0020/0050 :81446628-001

for CMS0200 :81446721-001

for CMS0500 :81446856-001

Hole dimensions when mounting bracket is used

• CMS9500/0002/0005/0020/0050 unit : mm

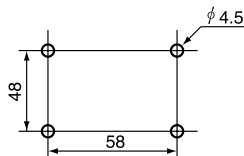

• CMS0200

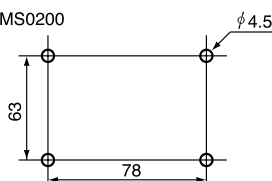

• CMS0500

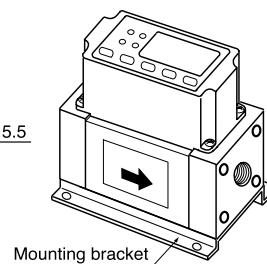
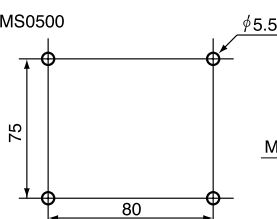

■ Wiring

⚠ CAUTION



When using a relay as the contact for integrated count reset input, use a relay (gold contact type) for trace currents. Otherwise, defective contact may cause the device to malfunction.



When wiring, take care not to tug the display. The components inside might become damaged.



Be sure to check that the wiring is correct before you turn the power ON. Incorrect wiring might cause damage or malfunction.

We recommend using a harness (sold separately) with special connector.

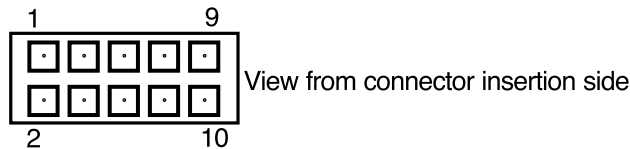

● Connector Pin Layout

The following shows the layout of the connector pins on this flow meter:

Compatible connector:

DF11-10DS-2C made by HIROSE ELECTRIC CO., LTD.

Harness with special connector:

- For models without display meter
Model number: 81446594-001 (harness length: 2m)
81446594-002 (harness length: 5m)
- For models with display meter
Model number: 81446594-005 (harness length: 2m)
81446594-006 (harness length: 5m)
- For connection models without display meter to multi channel indicator (CMW100A101)
Model number: 81446594-011 (harness length: 5m)

● Connector signal names

Pin No.	Signal name	Description	Remarks
1	DC OUT+	Instantaneous flowrate output +	
2	DC OUT -	Instantaneous flowrate output -	
3	V +	Power+(DC12 to 24V)	
4	GND	Power GND	
5		For connection to multi-channel indicator	Connect only when a multi-channel indicator is used
6			
7	DI	Integration count reset input	
8	EV 2	Event 2 output / Integration pulse output	
9	EV 1	Event 1 output / Serial data output	
10	EV COM	Event output common	

● Connection example

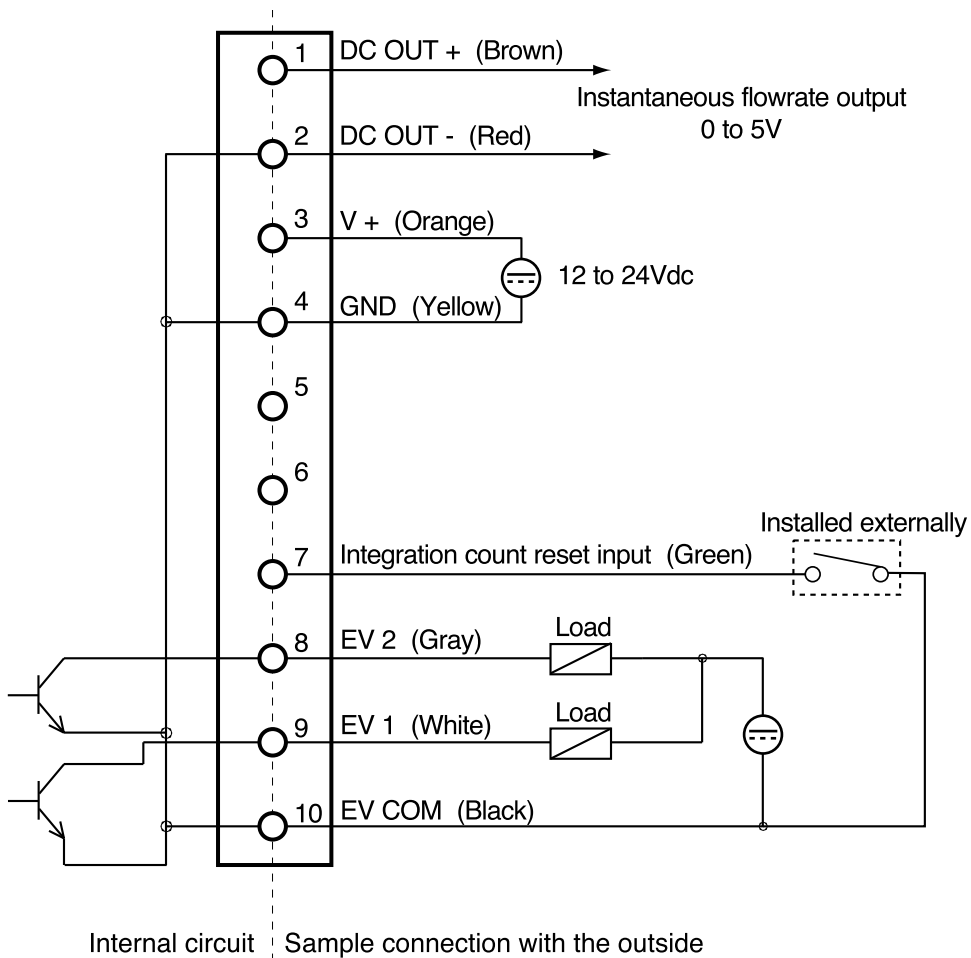

● When using flowrate data serial output

- Connection example

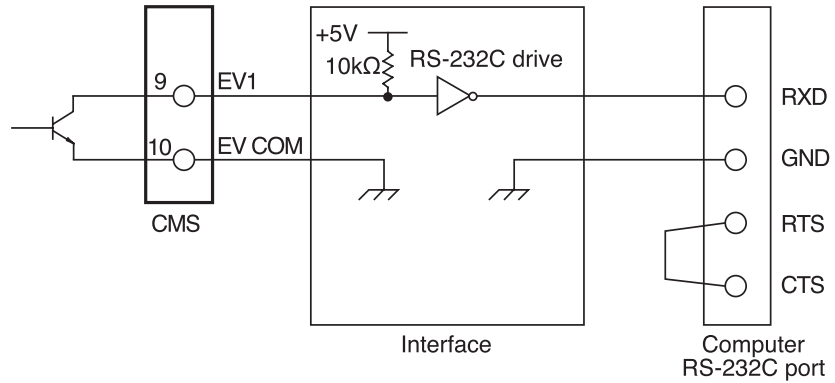

- Communications protocol

Currently displayed instantaneous flowrate data and integrated flowrate data is sent as ASCII code.

Data is sent in order instantaneous flowrate data followed by integrated flowrate data. Instantaneous flowrate data is prefixed with "F" and integrated flowrate data is prefixed with "T".

Example: When instantaneous flowrate is 100.L/min (standard), and integrated flowrate is 100 x 10L.

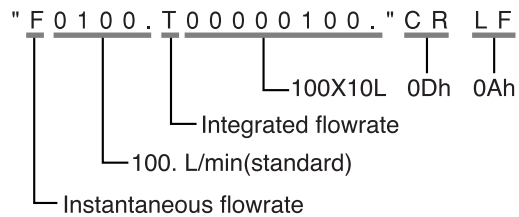

- Communications specifications

Item	Description
Communication system	Conform to RS-232C, Start-stop transmission
Transmission speed	2400bps
Character length	8 bits
Stop bit	1 bit
Parity	None
Data transmission cycle	100±10ms

MEMO

Chapter 4. METHOD OF OPERATION (Models with Display Meter)

⚠ CAUTION



Do not operate the keys with a propelling pencil or sharp-tipped object. Doing so might cause faulty operation

When the power is turned ON, the instantaneous flowrate value is displayed. If gas is not flowing, 0 is displayed. Leave the device for about 30min with the power supply applied to stabilize the device before use.

■ Function setup

The following describes how to set up each of the functions:

- To enter the setup mode, press the **MODE** key.
The upper two digits on the display blink. The upper two digits on the display indicate the function type, and the lower two digits indicate the setup.
- Pressing the **▼** key moves the setup to the next item. Pressing the **▲** key moves the setup item to the previous item.

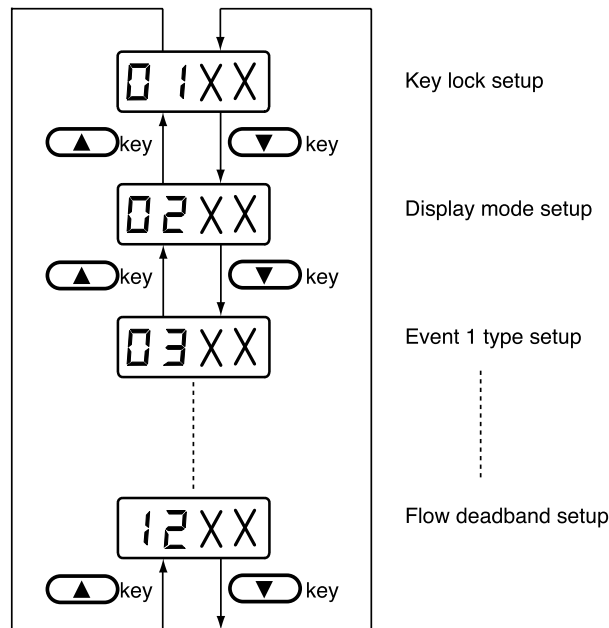

- Pressing the **▼** key again when **12** is displayed returns the display to **01**. Pressing the **▲** key again when **01** is displayed changes the display to **12**.
- When the upper two digits are the setup item that you want to set, press the **ENT** key while it is blinking.
This selects the setup item, and the lower two digits blink.
- Press the **▲** and **▼** keys to select the desired setting value, and press the **ENT** key.
All four digits light.
- Make sure that the items and the setups are correct.
- To continue setup, press the **MODE** key again and repeat the setup operation

The following table shows the function and the setup:

● CMS9500

Mode	Function	Setting value	Setup	Remarks
01	Key lock	00 01	Key lock disabled Lock ON	Other modes cannot be entered in a key lock state.
02	Display mode	00 01 02	Only instantaneous flowrate displayed Instantaneous flowrate/integrated flowrate displayed Instantaneous flowrate/reverse integrated flowrate displayed	Pressing the (DISP) key switches the display.
03	Event 1 type (EV1)	00 01 02 03 04 05	Not used Instantaneous flowrate upper limit value Instantaneous flowrate lower limit value Integrated flowrate count up Reverse integrated flowrate count down Flowrate data serial output	Same event types cannot be set to events 1 and 2 simultaneously. Also, integrating countup and reverse-integrating countdown cannot be set simultaneously.
04	Event 2 type (EV2)	00 01 02 03 04 05 06 07	Not used Instantaneous flowrate upper limit value Instantaneous flowrate lower limit value Integrated flowrate count up Reverse integrated flowrate count down Integration pulse output 10mL/pulse Integration pulse output 100mL/pulse Integration pulse output 1000mL/pulse	Integrated countup, reverse-integrated countdown, and the action of integration pulse output are effective only when the mode 02 is set to 01 or 02.
05	ON delay setting (EV1)	00 01	Not used Used	Displayed only when mode 03 is set to 01 or 02.
06	ON delay setting (EV2)	00 01	Not used Used	Displayed only when mode 04 is set to 01 or 02.
07	Event standby setting	00 01	Not used Used	Displayed only when mode 03 or 04 is set to 02.
08	Gas type selection	00 01 02 03 04 05 06 07 08	Air/Nitrogen Argon Carbon dioxide (CO2) Oxygen City gas 13A (LNG) Methane 100% Propane 100% Butane Gas type user setup function	You can select 03 only when gas type S (oxygen) is specified. When the other gas type is specified, you can select from among 00, 01, 02, 04, 05, 06, 07 and 08.
10	Analog output scaling	00 01 02 03	0 to 500mL/min (standard) 0 to 300mL/min (standard) 0 to 200mL/min (standard) 0 to 100mL/min (standard)	see page 20.
11	Flowrate conversion reference temperature	00 01 02	Referenced to 20°C in air (1.00) Referenced to 0°C in air (1.00) Referenced to 25°C in air (1.00)	
12	Flow deadband setting	00 01 02 03	No deadband Less than 2mL/min (standard) Less than 5mL/min (standard) Less than 10mL/min (standard)	When gas type 08 is selected, less approx. 2 X CF, approx.5 X CF, and approx.10 X CF mL/min (standard) become the deadband. CF refers to the conversion factor according to gas type, and its range is 0.10 to 8.00.

● CMS0002/0005

Mode	Function	Setting value	Setup	Remarks
01	Key lock	00 01	Key lock disabled Lock ON	Other modes cannot be entered in a key lock state.
02	Display mode	00 01 02	Only instantaneous flowrate displayed Instantaneous flowrate/integrated flowrate displayed Instantaneous flowrate/reverse integrated flowrate displayed	Pressing the (DISP) key switches the display.
03	Event 1 type (EV1)	00 01 02 03 04 05	Not used Instantaneous flowrate upper limit value Instantaneous flowrate lower limit value Integrated flowrate count up Reverse integrated flowrate count down Flowrate data serial output	Same event types cannot be set to events 1 and 2 simultaneously. Also, integrating countup and reverse-integrating countdown cannot be set simultaneously.
04	Event 2 type (EV2)	00 01 02 03 04 05 06 07	Not used Instantaneous flowrate upper limit value Instantaneous flowrate lower limit value Integrated flowrate count up Reverse integrated flowrate count down Integration pulse output 1L/pulse Integration pulse output 10L/pulse Integration pulse output 100L/pulse	Integrated countup, reverse-integrated countdown, and the action of integration pulse output are effective only when the mode 02 is set to 01 or 02.
05	ON delay setting (EV1)	00 01	Not used Used	Displayed only when mode 03 is set to 01 or 02.
06	ON delay setting (EV2)	00 01	Not used Used	Displayed only when mode 04 is set to 01 or 02.
07	Event standby setting	00 01	Not used Used	Displayed only when mode 03 or 04 is set to 02.
08	Gas type selection	00 01 02 03 04 05 06 07 08	Air/Nitrogen Argon Carbon dioxide (CO2) Oxygen City gas 13A (LNG) Methane 100% Propane 100% Butane Gas type user setup function	You can select 03 only when gas type S (oxygen) is specified. When the other gas type is specified, you can select from among 00, 01, 02, 04, 05, 06, 07 and 08.
09	Analog output scaling (CMS0002)	00 01 02 03	0 to 2 L/min (standard) 0 to 1 L/min (standard) 0 to 0.5 L/min (standard) 0 to 0.2 L/min (standard)	see page 20.
10	Analog output scaling (CMS0005)	00 01 02 03	0 to 5 L/min (standard) 0 to 3 L/min (standard) 0 to 2 L/min (standard) 0 to 1 L/min (standard)	see page 20.
11	Flowrate conversion reference temperature	00 01 02	Referenced to 20°C in air (1.00) Referenced to 0°C in air (1.00) Referenced to 25°C in air (1.00)	
12	Flow deadband setting	00 01 02 03	No deadband Less than 0.2L/min (standard) Less than 0.5L/min (standard) Less than 1.0L/min (standard)	When gas type 08 is selected, less approx.0.02 X CF, approx.0.05 X CF, and approx.0.1 X CF L/min (standard) become the deadband. CF refers to the conversion factor according to gas type, and its range is 0.10 to 8.00.

● CMS002/0005

Mode	Function	Setting value	Setup	Remarks
01	Key lock	00 01	Key lock disabled Lock ON	Other modes cannot be entered in a key lock state.
02	Display mode	00 01 02	Only instantaneous flowrate displayed Instantaneous flowrate/integrated flowrate displayed Instantaneous flowrate/reverse integrated flowrate displayed	Pressing the (DISP) key switches the display.
03	Event 1 type (EV1)	00 01 02 03 04 05	Not used Instantaneous flowrate upper limit value Instantaneous flowrate lower limit value Integrated flowrate count up Reverse integrated flowrate count down Flowrate data serial output	Same event types cannot be set to events 1 and 2 simultaneously. Also, integrating countup and reverse-integrating countdown cannot be set simultaneously.
04	Event 2 type (EV2)	00 01 02 03 04 05 06 07	Not used Instantaneous flowrate upper limit value Instantaneous flowrate lower limit value Integrated flowrate count up Reverse integrated flowrate count down Integration pulse output 1L/pulse Integration pulse output 10L/pulse Integration pulse output 100L/pulse	Integrated countup, reverse-integrated countdown, and the action of integration pulse output are effective only when the mode 02 is set to 01 or 02.
05	ON delay setting (EV1)	00 01	Not used Used	Displayed only when mode 03 is set to 01 or 02.
06	ON delay setting (EV2)	00 01	Not used Used	Displayed only when mode 04 is set to 01 or 02.
07	Event standby setting	00 01	Not used Used	Displayed only when mode 03 or 04 is set to 02.
08	Gas type selection	00 01 02 03 04 05 06 07 08	Air/Nitrogen Argon Carbon dioxide (CO2) Oxygen City gas 13A (LNG) Methane 100% Propane 100% Butane Gas type user setup function	You can select 00, 01 and 02 on the PBT resin model. On the SUS316 model, you can select 03 only when gas type S (oxygen) is specified. When the other gas type is specified, you can select from among 00, 01, 02, 04, 05, 06, 07 and 08.
09	Analog output scaling (CMS0020)	00 01 02 03	0 to 20 L/min (standard) 0 to 10 L/min (standard) 0 to 5 L/min (standard) 0 to 2 L/min (standard)	see page 20.
10	Analog output scaling (CMS0050)	00 01 02 03	0 to 50 L/min (standard) 0 to 30 L/min (standard) 0 to 20 L/min (standard) 0 to 10 L/min (standard)	see page 20.
11	Flowrate conversion reference temperature	00 01 02	Referenced to 20°C in air (1.00) Referenced to 0°C in air (1.00) Referenced to 25°C in air (1.00)	
12	Flow deadband setting	00 01 02 03	No deadband Less than 0.2L/min (standard) Less than 0.5L/min (standard) Less than 1.0L/min (standard)	When gas type 08 is selected, less approx.0.2 X CF, approx.0.5 X CF, and approx.1.0 X CF L/min (standard) become the deadband. CF refers to the conversion factor according to gas type, and its range is 0.10 to 8.00.

● CMS0200/0500

Mode	Function	Setting value	Setup	Remarks
01	Key lock	00 01	Key lock disabled Lock ON	Other modes cannot be entered in a key lock state.
02	Display mode	00 01 02	Only instantaneous flowrate displayed Instantaneous flowrate/integrated flowrate displayed Instantaneous flowrate/reverse integrated flowrate displayed	Pressing the (DISP) key switches the display.
03	Event 1 type (EV1)	00 01 02 03 04 05	Not used Instantaneous flowrate upper limit value Instantaneous flowrate lower limit value Integrated flowrate count up Reverse integrated flowrate count down Flowrate data serial output	Same event types cannot be set to events 1 and 2 simultaneously. Also, integrating countup and reverse-integrating countdown cannot be set simultaneously.
04	Event 2 type (EV2)	00 01 02 03 04 05 06 07	Not used Instantaneous flowrate upper limit value Instantaneous flowrate lower limit value Integrated flowrate count up Reverse integrated flowrate count down Integration pulse output 10L/pulse Integration pulse output 100L/pulse Integration pulse output 1000L/pulse	Integrated countup, reverse-integrated countdown, and the action of integration pulse output are effective only when the mode 02 is set to 01 or 02.
05	ON delay setting (EV1)	00 01	Not used Used	Displayed only when mode 03 is set to 01 or 02.
06	ON delay setting (EV2)	00 01	Not used Used	Displayed only when mode 04 is set to 01 or 02.
07	Event standby setting	00 01	Not used Used	Displayed only when mode 03 or 04 is set to 02.
08	Gas type selection	00 01 02 03 04 05 06 07 08	Air/Nitrogen Argon Carbon dioxide (CO2) Oxygen City gas 13A (LNG) Methane 100% Propane 100% Butane Gas type user setup function	You can select 03 only when gas type S (oxygen) is specified. When the other gas type is specified, you can select from among 00, 01, 02, 04, 05, 06, 07 and 08.
09	Analog output scaling (CMS0200)	00 01 02 03	0 to 200 L/min (standard) 0 to 100 L/min (standard) 0 to 50 L/min (standard) 0 to 20 L/min (standard)	see page 20.
10	Analog output scaling (CMS0500)	00 01 02 03	0 to 500 L/min (standard) 0 to 300 L/min (standard) 0 to 200 L/min (standard) 0 to 100 L/min (standard)	see page 20.
11	Flowrate conversion reference temperature	00 01 02	Referenced to 20°C in air (1.00) Referenced to 0°C in air (1.00) Referenced to 25°C in air (1.00)	
12	Flow deadband setting	00 01 02 03	No deadband Less than 2L/min (standard) Less than 5L/min (standard) Less than 10L/min (standard)	When gas type 08 is selected, less approx.2 X CF, approx.5 X CF, and approx.10 X CF L/min (standard) become the deadband. CF refers to the conversion factor according to gas type, and its range is 0.10 to 8.00.

*** Analog output scaling**

You can specify the scaling of the voltage output 0 through 5V.

When **08** Gas type selection is changed, the range of flowrate measurement changes as specified in "maximum measured flowrate for each gas type" on page 32. However, this function produces an output by the preset scaling regardless of what gas type has been selected.

Sample: In CMS0050, if **08** Gas type selection is changed to **02** (Carbon dioxide), the range of flowrate measurement changes to "0 to 25 L/min".

If you set the scaling to 01 (0 to 30 L/min), the 0 to 5V output is produced as shown in the figure below:

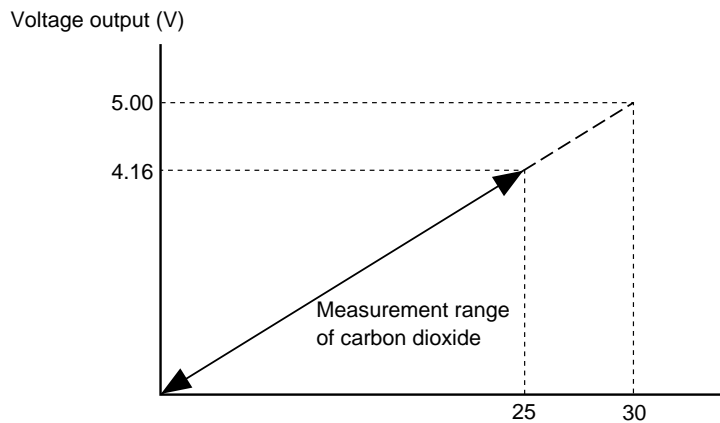

The maximum voltage output is calculated as follows when the output scaling has been set up:

- When gas types **00** to **07** are selected

$$\frac{\text{measured flowrate of preset gas}}{\text{scaling upper limit value}} \times 5V$$
- When gas type **08** is selected

$$\frac{\text{measured flowrate of preset gas}}{\text{scaling upper limit value}} \times \frac{1}{\text{gas type compensation coefficient}} \times 5V$$

For details on the preset gas measurement flowrate, see page 34.

The gas type compensation coefficient is the value preset in Parameter Setup on page 21.

! Handling Precautions

- Factory settings (excluding gas type) are **00**.
- Pressing the **MODE** key during operation, returns to the previous setting value, and enters the setup mode.

Note

For details of event standby, see page 26.

■ Parameter setup

Cancel the function setup key lock setting (key lock disabled).

Set the setting value of function setup modes 03 and 04 to other than 00.

To enter the parameter setup mode, hold down the **ENT** and **▼** keys simultaneously for at least three seconds.

In the parameter setup mode, *P-*** is displayed on the display. The lower two digits on flowrate display indicate the parameter item.

Pressing the **▼** key moves the setup to the next item. Pressing the **▲** key moves the setup item to the previous item.

Pressing the **▼** key again while *P-07* or *P-08* function is displayed returns the display to *P-01*. Alternately, pressing the **▲** key again while *P-01* is displayed returns the display to *P-07* or *P-08* function.

Press the **ENT** key at the item you want to set.

The current setting value is displayed.

If you press the **ENT** key again, the lowermost digit blinks.



If you press the **MODE** key, the blinking cursor moves to the left. To change the setting value at each of these digits, use the **▲** and **▼** keys.

When 03 or 04 has been set as the event type in the function setup, setup the 8-digit display at *P-01*, *02* and *07*.

To do this, switch between the upper 4-digit and lower 4-digit display as follows:

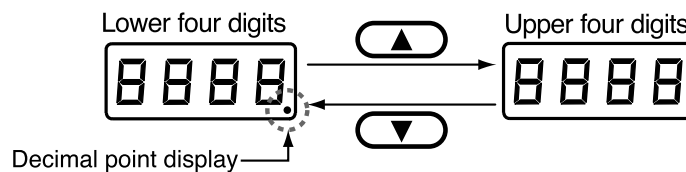

P-01 to *P-07* or *P-08* function is displayed according to the setting values of the function setup.

The following table shows available parameters and setting values:

● CMS9500

Parameter	Item	Factory setting	Setting range	The conditions of display (Setting mode of function)
P-01	Event 1 setting value (EV1)	0.	0 to 500 (mL/min(standard)) *1	when 03 is 01 or 02
		00000000	00000000 to 99999999 (X 10mL)	when 03 is 03 or 04
P-02	Event 2 setting value (EV2)	0.	0 to 500 (mL/min) (standard)) *1	when 04 is 01 or 02
		00000000	00000000 to 99999999 (X 10mL)	when 04 is 03 or 04
P-03	EV1 hysteresis	50.	0 to 100 (mL/min(standard))	when 03 is 01 or 02
P-04	EV2 hysteresis	50.	0 to 100 (mL/min(standard))	when 04 is 01 or 02
P-05	EV1 ON delay	0	0 to 60 (s)	when 03 is 01 or 02
P-06	EV2 ON delay	0	0 to 60 (s)	when 04 is 01 or 02
P-07	Reverse-integrated default	00000000	00000000 to 99999999 (X 10mL)	when 02 is 02
P-08	Gas type conversion factor	1.00	0.10 to 8.00	when 08 is 08

● CMS0002

Parameter	Item	Factory setting	Setting range	The conditions of display (Setting mode of function)
P-01	Event 1 setting value (EV1)	0.00	0 to 2.00 (L/min(standard)) *1 *2	when 03 is 01 or 02
		00000000	00000000 to 99999999 (L)	when 03 is 03 or 04
P-02	Event 2 setting value (EV2)	0.00	0 to 2.00 (L/min)(standard)) *1 *2	when 04 is 01 or 02
		00000000	00000000 to 99999999 (L)	when 04 is 03 or 04
P-03	EV1 hysteresis *3	0.50	0 to 1.00 (L/min(standard)) *3	when 03 is 01 or 02
P-04	EV2 hysteresis *3	0.50	0 to 1.00 (L/min(standard)) *3	when 04 is 01 or 02
P-05	EV1 ON delay	0	0 to 60 (s)	when 03 is 01 or 02
P-06	EV2 ON delay	0	0 to 60 (s)	when 04 is 01 or 02
P-07	Reverse-integrated default	00000000	00000000 to 99999999 (L)	when 02 is 02
P-08	Gas type conversion factor	1.00	0.10 to 8.00	when 08 is 08

● CMS0005

Parameter	Item	Factory setting	Setting range	The conditions of display (Setting mode of function)
P-01	Event 1 setting value (EV1)	0.00	0 to 5.00 (L/min(standard)) *1	when 03 is 01 or 02
		00000000	00000000 to 99999999 (L)	when 03 is 03 or 04
P-02	Event 2 setting value (EV2)	0.00	0 to 5.00 (L/min)(standard)) *1	when 04 is 01 or 02
		00000000	00000000 to 99999999 (L)	when 04 is 03 or 04
P-03	EV1 hysteresis *3	0.50	0 to 1.00 (L/min(standard))	when 03 is 01 or 02
P-04	EV2 hysteresis *3	0.50	0 to 1.00 (L/min(standard))	when 04 is 01 or 02
P-05	EV1 ON delay	0	0 to 60 (s)	when 03 is 01 or 02
P-06	EV2 ON delay	0	0 to 60 (s)	when 04 is 01 or 02
P-07	Reverse-integrated default	00000000	00000000 to 99999999 (L)	when 02 is 02
P-08	Gas type conversion factor	1.00	0.10 to 8.00	when 08 is 08

● CMS0020

Parameter	Item	Factory setting	Setting range	The conditions of display (Setting mode of function)
P-01	Event 1 setting value (EV1)	0.0	0 to 20.0 (L/min(standard)) *1 *2	when 03 is 01 or 02
		00000000	00000000 to 99999999 (L)	when 03 is 03 or 04
P-02	Event 2 setting value (EV2)	0.0	0 to 20.0 (L/min)(standard)) *1 *2	when 04 is 01 or 02
		00000000	00000000 to 99999999 (L)	when 04 is 03 or 04
P-03	EV1 hysteresis *3	5.0	0 to 10.0 (L/min(standard)) *3	when 03 is 01 or 02
P-04	EV2 hysteresis *3	5.0	0 to 10.0 (L/min(standard)) *3	when 04 is 01 or 02
P-05	EV1 ON delay	0	0 to 60 (s)	when 03 is 01 or 02
P-06	EV2 ON delay	0	0 to 60 (s)	when 04 is 01 or 02
P-07	Reverse-integrated default	00000000	00000000 to 99999999 (L)	when 02 is 02
P-08	Gas type conversion factor	1.00	0.10 to 8.00	when 08 is 08

● CMS0050

Parameter	Item	Factory setting	Setting range	The conditions of display (Setting mode of function)
P-01	Event 1 setting value (EV1)	0.0	0 to 50.0 (L/min(standard)) *1	when 03 is 01 or 02
		00000000	00000000 to 99999999 (L)	when 03 is 03 or 04
P-02	Event 2 setting value (EV2)	0.0	0 to 50.0 (L/min)(standard)) *1	when 04 is 01 or 02
		00000000	00000000 to 99999999 (L)	when 04 is 03 or 04
P-03	EV1 hysteresis *3	5.0	0 to 10.0 (L/min(standard))	when 03 is 01 or 02
P-04	EV2 hysteresis *3	5.0	0 to 10.0 (L/min(standard))	when 04 is 01 or 02
P-05	EV1 ON delay	0	0 to 60 (s)	when 03 is 01 or 02
P-06	EV2 ON delay	0	0 to 60 (s)	when 04 is 01 or 02
P-07	Reverse-integrated default	00000000	00000000 to 99999999 (L)	when 02 is 02
P-08	Gas type conversion factor	1.00	0.10 to 8.00	when 08 is 08

● CMS0200

Parameter	Item	Factory setting	Setting range	The conditions of display (Setting mode of function)
P-01	Event 1 setting value (EV1)	0.	0 to 200 (L/min(standard)) *1 *2	when 03 is 01 or 02
		00000000	00000000 to 99999999 (L)	when 03 is 03 or 04
P-02	Event 2 setting value (EV2)	0.	0 to 200 (L/min)(standard)) *1 *2	when 04 is 01 or 02
		00000000	00000000 to 99999999 (L)	when 04 is 03 or 04
P-03	EV1 hysteresis *3	50.	0 to 100 (L/min(standard)) *3	when 03 is 01 or 02
P-04	EV2 hysteresis *3	50.	0 to 100 (L/min(standard)) *3	when 04 is 01 or 02
P-05	EV1 ON delay	0	0 to 60 (s)	when 03 is 01 or 02
P-06	EV2 ON delay	0	0 to 60 (s)	when 04 is 01 or 02
P-07	Reverse-integrated default	00000000	00000000 to 99999999 (L)	when 02 is 02
P-08	Gas type conversion factor	1.00	0.10 to 8.00	when 08 is 08

● CMS0500

Parameter	Item	Factory setting	Setting range	The conditions of display (Setting mode of function)
P-01	Event 1 setting value (EV1)	0.	0 to 500 (L/min(standard)) *1	when 03 is 01 or 02
		00000000	00000000 to 99999999 (X 10L)	when 03 is 03 or 04
P-02	Event 2 setting value (EV2)	0.	0 to 500 (L/min) *1	when 04 is 01 or 02
		00000000	00000000 to 99999999 (X 10L)	when 04 is 03 or 04
P-03	EV1 hysteresis *3	50.	0 to 100 (L/min(standard))	when 03 is 01 or 02
P-04	EV2 hysteresis *3	50.	0 to 100 (L/min(standard))	when 04 is 01 or 02
P-05	EV1 ON delay	0	0 to 60 (s)	when 03 is 01 or 02
P-06	EV2 ON delay	0	0 to 60 (s)	when 04 is 01 or 02
P-07	Reverse-integrated default	00000000	00000000 to 99999999 (X 10L)	when 02 is 02
P-08	Gas type conversion factor	1.00	0.10 to 8.00	when 08 is 08

 Note

*1 In case of gas type 08 the range becomes:

CMS9500/0200/0500 0 to 999

CMS0002/0005 0.00 to 9.99

CMS0020/0050 0.0 to 99.9.

However, use at a set point within setting range.

*2 In case of gas type 08, and when P-08 (conversion factor) is set to 0.10 to 0.49, the range becomes:

CMS0002 0.000 to 0.995 (in 0.005 increments)

CMS0020 0.00 to 9.95 (in 0.05 increments)

CMS0200 0.0 to 99.5 (in 0.5 increments).

However, use at a set point within setting range.

*3 In case of gas type 08, and when P-08 (conversion factor) is set to 0.10 to 0.49, the range becomes:

	Factory setting	Setting range
CMS0002	0.05	0.000 to 0.100 (in 0.005 increments)
CMS0020	0.5	0.00 to 1.00 (in 0.05 increments)
CMS0200	5.0	0.0 to 10.0 (in 0.5 increments)

■ State transition

In the factory default settings, when the device is turned on, the instantaneous flowrate indicator lamp lights to indicate the instantaneous flowrate.

The diagram below shows the relationship between migration modes and display (the case of CMS0500).

If 0201 or 0202 has been set in the display mode setup, the low-order four digits of the integrated flowrate or reverse-integrated flowrate are displayed by pressing the **DISP** key while the instantaneous flowrate is displayed.

Pressing the **DISP** key again returns the display to the high-order four digits of the instantaneous flowrate or reverse-integrated flowrate are displayed. Pressing the **DISP** key again returns the display to the instantaneous flowrate display.

When the power is turned OFF then back ON again, the display state returns to that before the power was turned OFF.

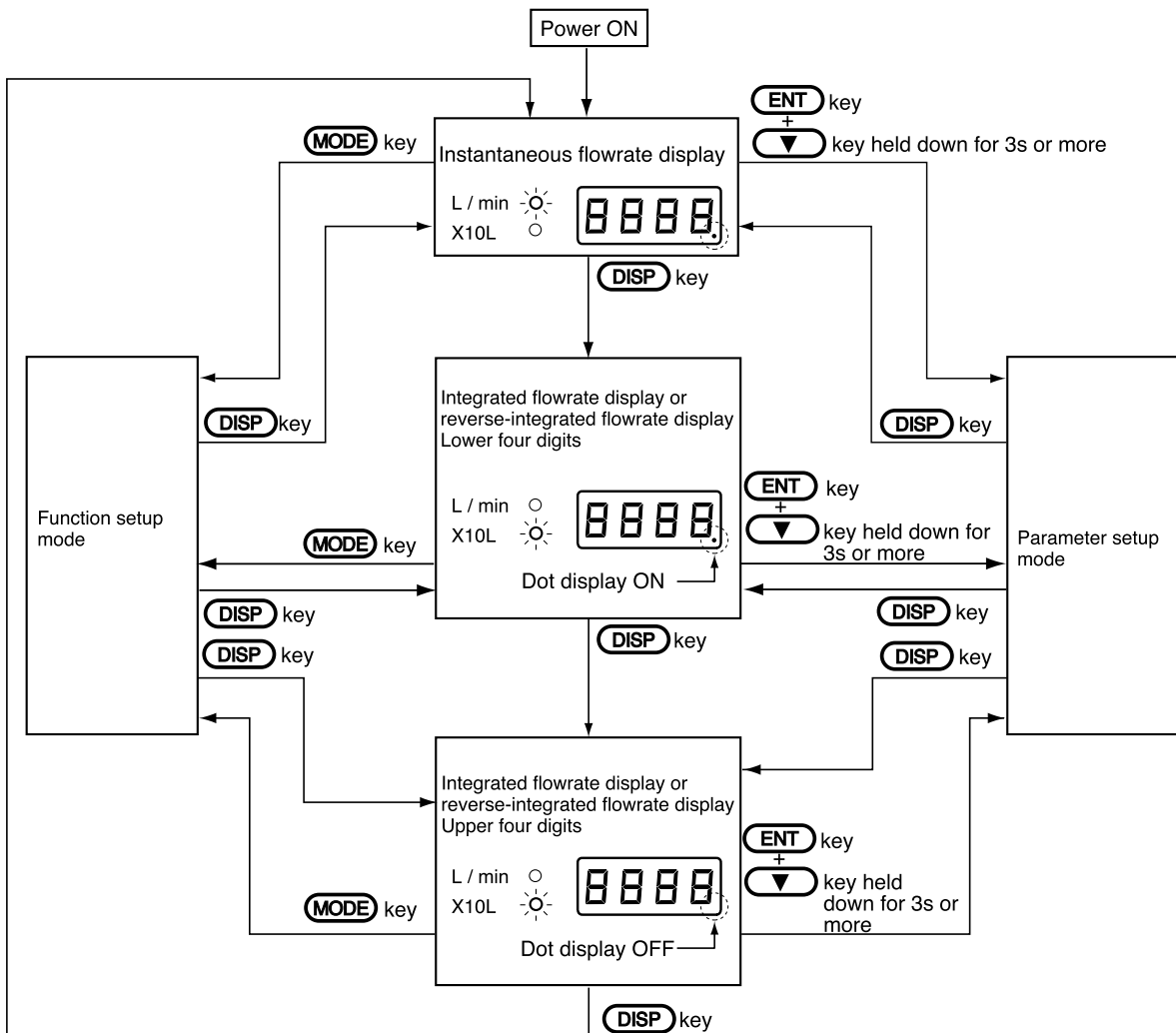

■ Integration

If the integrated value has exceeded 99999999, the value returns to 0 and the counting up operation continues. At this time, the event output of the integrated flowrate countup is kept OFF until the set value is reached again. Also, the countdown of the reverse-integrated value stops when 0 is reached.

■ Resetting the integrated value and reverse-integrated value

To reset the integrated/reverse-integrated value, hold down the ▲ and ▼ keys simultaneously for at least one second with the integrated/reverse-integrated value displayed.

The integrated value is reset to 0 and the reverse-integrated value is reset to the default, and integration/reverse-integration is resumed.

■ What is "Event standby?"

"Event standby" is enabled only on the instantaneous flowrate lower limit value. This function prevents erroneous operation of the lower limit alarm when there is no gas flowrate, for example, when the device is started up. There is no event action until the instantaneous flowrate value once exceeds the event lower limit setting value after the power is turned ON. Event action is normal after the event lower limit setting value has been exceeded once.

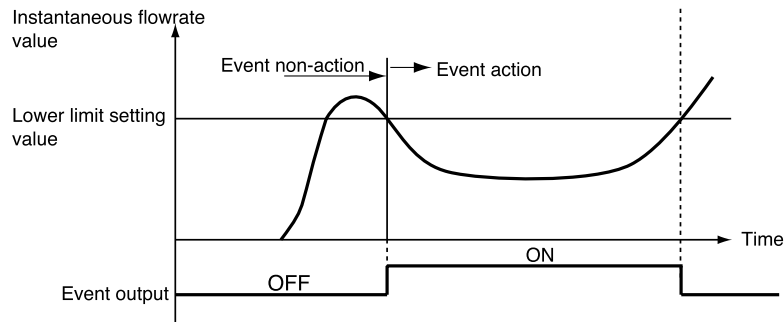

■ Event ON delay

ON delay times (0 to 60s) are set for each of events 1 and 2.

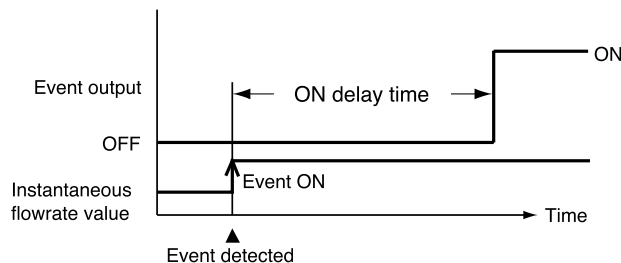

Chapter 5. TROUBLESHOOTING

■ Remediating trouble

In the case of models with display meter, refer to the following table if trouble occurs:

In the case of models without display meter, please contact Yamatake.

Phenomena	Countermeasure
Nothing on display	<ul style="list-style-type: none"> • Make sure that power of correct voltage and polarity is being supplied. • Make sure that connectors are correctly connected.
ALH1 displayed	<p>The instantaneous flowrate value has exceeded 20% of the upper flowrate range limit. Lower the instantaneous flowrate value so that it is within the flowrate range.</p>
Err1 displayed	<p>Sensor error Contact Yamatake Corporation and ask for repair.</p>
Err2 displayed	<p>Memory data error Contact Yamatake Corporation and ask for repair.</p>
Signal is output even though the flowrate should be zero	<ul style="list-style-type: none"> • Check the piping for any gas leaks. • Check the piping and connection ports for dirt, oil or other foreign matter. If oil is adhering to these parts, contact Yamatake.
Flowrate deviates	<ul style="list-style-type: none"> • Check the piping for any gas leaks. • Check the piping and connection ports for dirt, oil or other foreign matter. If oil is adhering to these parts, contact Yamatake. • Check the wiring to make sure that it is correct. • Check the flowrate to see that it does not deviate considerably within several seconds, or that it does not greatly exceed the measurement range.
Display is not zero even though the flowrate should be zero.	<ul style="list-style-type: none"> • Check the piping for any gas leaks or check if gas flow stops. • Even if the instantaneous flowrate display is 0, a minute flow smaller than the minimum display value of this device should be produced. In an integrating operation, even a flow under the minimum display value is counted. Set the flow deadband to remove the countup of integrated value (or countdown of reverse-integrated value). <p>(👉 See ■ Function setup, page 15)</p>

Chapter 6. SPECIFICATIONS

■ General specifications

● SUS/SUS316 model

Item		CMS9500	CMS0002	CMS0005	
Applicable gas		Air, Nitrogen, Argon, Oxygen, Carbon dioxide (CO ₂), City gas 13A (limited to LNG), Methane 100%, Propane 100%, Butane 100% However, gas must be a dry gas which does not contain any corrosive component (chlorine, sulfur, acid, etc.). It also must be a clean gas which does not contain dust nor oil mist.			
Air flowrate range *1		0 to 500 mL/min(standard)	0 to 2 L/min(standard)	0 to 5 L/min(standard)	
"standard" refers to a flowrate after conversion to 20°C, 1 atmosphere.					
Maximum measured flowrate for each gas type (1 atmosphere, 20°C conversion) *2	Air/Nitrogen	500 mL/min	2 L/min	5 L/min	
	Argon	500 mL/min	2 L/min	5 L/min	
	Carbon dioxide	250 mL/min	1 L/min	3.3 L/min	
	Oxygen	500 mL/min	2 L/min	5 L/min	
	City gas 13A *3	400 mL/min	1.5 L/min	4.5 L/min	
	Methane	500 mL/min	2 L/min	5 L/min	
	Propane	140 mL/min	0.5 L/min	1.7 L/min	
	Butane	100 mL/min	0.4 L/min	1.25 L/min	
Measurement accuracy at 20°C, 1 atmosphere (χ is the measured flowrate) *4		5≤χ<100mL/min ±1%FS±1digit 100≤χ≤500mL/min ±3%RD±1digit	0.02≤χ<0.4L/min ±1%FS±1digit 0.4≤χ≤2L/min 3%RD±1digit	0.05≤χ<1L/min 1%FS±1digit 1≤χ≤5L/min 3%RD±1digit	
Temperature characteristics at 0 to 50 *5		Flowrate range of 0 to 75% ±0.10%FS/°C ±1digit or less 75 to 100% ±0.15%FS/°C ±1digit or less			
Pressure characteristics *6	Applied pressure 0 to 1.0 MPa	±0.1%FS / 0.1MPa ±1digit or less		±0.25%FS / 0.1MPa ±1digit or less	
	Applied pressure (negative pressure) -0.07 to 0MPa	±0.2%FS / 0.01MPa ±1digit or less			
Operating temperature range		0 to 50°C			
Storage temperature range		-20 to +70°C			
Operating humidity range		10 to 90%RH (condensation not allowed)			
Operating pressure range		-0.07 to 1.0MPa			
Pressure resistance		1.5MPa			
Connection aperture/ Connection standard		SUS model:Rc 1/4 SUS316 model:9/16-18 UNF, Rc 1/4, 1/4 Swagelok, 1/4 VCR (Select one suitable for the model No.)			
Body material		SUS model:SUS303 and SUS316 SUS316 model:SUS316			
Case material		Polycarbonate			
Mounting position		Horizontal mounting. (Meter section must not face down.) If this device is mounted vertically, it may drift causing an error while the flowrate is zero. For details, contact Yamatake.			
Rated voltage		12 to 24Vdc			
Supply voltage range		10.8 to 26.4Vdc			
Current consumption		100mA max.			
Sampling cycle		100ms±10ms			
Display	Flowrate display		7-segment LED 4-digit/selectable between instantaneous and integrated flowrates		
	Instantaneous flowrate	Min. display	1 mL/min	0.01 L/min (0.005 L/min) *7	0.01 L/min
		Resolution	1 mL/min	0.01 L/min (0.005 L/min) *7	0.01 L/min
	Integrated flowrate	Display unit	10 mL	1 L	
		Display range	0 to 99999999		
Data storage		Data is written to memory every 10min. (Integrated value can be reset by operating the keys or external contact input.)			
	Status display	Instantaneous flowrate display LED/Integrated flowrate display LED/Event display LED			

CMS0020	CMS0050	CMS0200	CMS0500
Air, Nitrogen, Argon, Oxygen, Carbon dioxide (CO ₂), City gas 13A (limited to LNG), Methane 100%, Propane 100%, Butane 100% However, gas must be a dry gas which does not contain any corrosive component (chlorine, sulfur, acid, etc.). It also must be a clean gas which does not contain dust nor oil mist.			
0 to 20 L/min(standard)	0 to 50 L/min(standard)	0 to 200 L/min(standard)	0 to 500 L/min(standard)
"standard" refers to a flowrate after conversion to 20°C, 1 atmosphere.			
20 L/min	50 L/min	200 L/min	500 L/min
20 L/min	50 L/min	200 L/min	500 L/min
10 L/min	25 L/min	100 L/min	250 L/min
20 L/min	50 L/min	200 L/min	500 L/min
15 L/min	40 L/min	150 L/min	400 L/min
20 L/min	50 L/min	200 L/min	500 L/min
5 L/min	14 L/min	50 L/min	140 L/min
5 L/min	12 L/min	50 L/min	120 L/min
0.2≤χ<2L/min ±1%FS±1digit 2≤χ≤20L/min ±3%RD±1digit	0.5≤χ<5L/min ±1%FS±1digit 5≤χ≤50L/min ±3%RD±1digit	2≤χ<20L/min 1%FS±1digit 20≤χ≤200L/min ±3%RD±1digit	5≤χ<50L/min 1%FS±1digit 50≤χ≤500L/min ±3%RD±1digit
Flowrate range of 0 to 75% ±0.10%FS/°C ±1digit or less 75 to 100% ±0.15%FS/°C ±1digit or less			
±0.2%FS / 0.1MPa ±1digit or less	±0.1%FS / 0.1MPa ±1digit or less	±0.2%FS / 0.1MPa ±1digit or less	
±0.2%FS / 0.01MPa ±1digit or less			
0 to 50°C			
-20 to +70°C			
10 to 90%RH (condensation not allowed)			
-0.07 to +1.0MPa			
1.5MPa			
SUS model:Rc 1/4 SUS316 model:9/16-18 UNF, Rc 1/4, 1/4 Swagelok, 1/4 VCR (Select one suitable for the model No.)		SUS303:Rc 1/2 SUS316 model:3/4-16 UNF, Rc 1/4, 1/2 Swagelok, 3/8 VCR (Select one suitable for the model No.)	
SUS model:SUS303 and SUS316 SUS316 model:SUS316			
Polycarbonate			
Horizontal mounting. (Meter section must not face down.) If this device is mounted vertically, it may drift causing an error while the flowrate is zero. For details, contact Yamatake.			
12 to 24Vdc			
10.8 to 26.4Vdc			
100mA max.			
100ms±10ms			
7-segment LED 4-digit/selectable between instantaneous and integrated flowrates			
0.1 L/min (0.05 L/min) *7	0.1 L/min	1 L/min (0.5 L/min) *7	1 L/min
0.1 L/min (0.05 L/min) *7	0.1 L/min	1 L/min (0.5 L/min) *7	1 L/min
1 L		10 L	
0 to 99999999			
Data is written to memory every 10min. (Integrated value can be reset by operating the keys or external contact input.)			
Instantaneous flowrate display LED/Integrated flowrate display LED/Event display LED			

Chapter 6. SPECIFICATIONS

Item		CMS9500	CMS0002	CMS0005
Output signal (instantaneous flowrate output)		0 to 5Vdc (allowable load resistance 10kΩmin.) 5.7V or more is not output even if the output exceeds the output range.		
Output scaling function *8		Selectable from 0 to 100, 0 to 200, 0 to 300, 0 to 500mL/min. Factory setting: 0 to 500mL/min.	Selectable from 0 to 0.2, 0 to 0.5, 0 to 1, 0 to 2 L/min. Factory setting: 0 to 2 L/min.	Selectable from 0 to 1, 0 to 2, 0 to 3, 0 to 5 L/min. Factory setting: 0 to 5 L/min.
Event output	Number of points	2		
	Output	Open collector (absolute maximum ratings 30Vdc, 50mA)		
	Description of event functions	For details, see attached tables 1, 2, 3 and 4.		
		Specify from among instantaneous flowrate upper limit/lower limit, integrated flowrate countup, reverse-integrated flowrate countdown, integration pulse output (event 2 only), flowrate data serial output (event 1).		
	External input	Number of points 1 (input dedicated to reset of integrated count)		
Input specifications	Circuit type on other side: No-voltage contact or open collector Contact OFF terminal voltage: 4.5±1V Contact ON terminal current: approx. 0.5mA (current flowing to contact) Allowable ON contact resistance: 250Ω max. Allowable OFF contact resistance: 100Ω min. Allowable ON residual voltage: 0.8V max. (open collector on other side) Allowable OFF leakage current: 50μA max. (open collector on other side)			
Serial data output		Open collector (absolute maximum ratings 30Vdc, 50mA)		
Gas type switching function		Air/Nitrogen, Argon, Carbon dioxide (CO ₂), Oxygen (only gas type S), City gas 13A (limited to LNG), Methane 100%, Propane 100%, Butane Select the gas type using the keys on the body		
Gas type setup function		Gas type conversion factor; set in the range between 0.10 and 8.00 using the keys on the body		
Electrical connection		Harness with a special connector (optional) Applicable connector: Hirose DF-11-10DS-2C		
Applicable standards		EN61326-1:1997 A1:1998		
Mass		Approx. 800 g		

CMS0020	CMS0050	CMS0200	CMS0500
0 to 5Vdc (allowable load resistance 10kΩmin.) 5.7V or more is not output even if the output exceeds the output range.			
Selectable from 0 to 2, 0 to 5, 0 to 10, 0 to 20 L/min. Factory setting: 0 to 20 L/min.	Selectable from 0 to 10, 0 to 20, 0 to 30, 0 to 50 L/min. Factory setting: 0 to 50 L/min.	Selectable from 0 to 20, 0 to 50, 0 to 100, 0 to 200 L/min. Factory setting: 0 to 200 L/min.	Selectable from 0 to 100, 0 to 200, 0 to 300, 0 to 500 L/min. Factory setting: 0 to 500 L/min.
2			
Open collector (absolute maximum ratings 30Vdc, 50mA)			
For details, see attached tables 1, 2, 3 and 4.			
Specify from among instantaneous flowrate upper limit/lower limit, integrated flowrate countup, reverse-integrated flowrate countdown, integration pulse output (event 2 only), flowrate data serial output (event 1).			
1 (input dedicated to reset of integrated count)			
Circuit type on other side:		No-voltage contact or open collector	
Contact OFF terminal voltage:		4.5±1V	
Contact ON terminal current:		approx. 0.5mA (current flowing to contact)	
Allowable ON contact resistance:		250Ω max.	
Allowable OFF contact resistance:		100kΩ min.	
Allowable ON residual voltage:		0.8V max. (open collector on other side)	
Allowable OFF leakage current:		50μA max. (open collector on other side)	
Open collector (absolute maximum ratings 30Vdc, 50mA)			
Air/Nitrogen, Argon, Carbon dioxide (CO ₂), Oxygen (only gas type S), City gas 13A (limited to LNG), Methane 100%, Propane 100%, Butane Select the gas type using the keys on the body			
Gas type conversion factor; set in the range between 0.10 and 8.00 using the keys on the body			
Harness with a special connector (optional) Applicable connector: Hirose DF-11-10DS-2C			
EN61326-1:1997 A1:1998			
Approx. 800 g		Approx. 1400 g	Approx. 2000 g

- *1: A flowrate range used in air. This product is provided with a gas type selecting function which enables you to select the desired gas type using the keys on the body.
See "Maximum measured flowrate and output voltage for each gas type" on page 34.
Also a scaling changing function is provided enabling you to change the scaling of 0 to 5V output using the keys on the body.
- *2: For the gases not listed in this table, some of them are applicable using the gas type conversion factor function. For details, contact Yamatake.
- *3: City gas 13A is based on a gas produced from LNG, of which 88% is methane CH₄. If the gas composition of your 13A is different, contact Yamatake.
- *4: The ambient temperature during adjustment is 25°C.
- *5: Amount of change on a flowrate referenced to 20°C under atmospheric pressure.
- *6: Amount of change on a flowrate referenced to atmospheric pressure at 20°C.
- *7: When the gas type conversion factor has been set to 0.10 to 0.49.
- *8: The scaling of the 0 to 5V voltage output can be changed using the keys on the body. When the gas type is changed, the range of flowrate measurement changes as specified in "maximum measured flowrate for each gas type" in the table. However, this function produces an output by the preset scaling regardless of what gas type has been selected.

● Resin model

Item		CMS0020	CMS0050	
Applicable gas		Air, Nitrogen, Argon, Oxygen, Carbon dioxide (CO ₂), City gas 13A (limited to LNG), Methane 100%, Propane 100%, Butane 100% However, gas must be a dry gas which does not contain any corrosive component (chlorine, sulfur, acid, etc.). It also must be a clean gas which does not contain dust nor oil mist.		
Air flowrate range *1		0 to 20 L/min(standard)	0 to 50 L/min(standard)	
"standard" refers to a flowrate after conversion to 20°C, 1 atmosphere.				
Maximum measured flowrate for each gas type (1 atmosphere, 20°C conversion) *2	Air/Nitrogen	20 L/min	50 L/min	
	Argon	20 L/min	50 L/min	
	Carbon dioxide	10 L/min	25 L/min	
Measurement accuracy at 20°C, 1 atmosphere (χ is the measured flowrate) *3		0.2 $\leq\chi$ <4L/min $\pm 1\%FS\pm 1$ digit 4 $\leq\chi$ \leq 20L/min $\pm 5\%RD\pm 1$ digit	0.5 $\leq\chi$ <5L/min $\pm 1\%FS\pm 1$ digit 5 $\leq\chi$ \leq 50L/min $\pm 5\%RD\pm 1$ digit	
Temperature characteristics at 0 to 35°C *4		0.2 $\leq\chi$ <4L/min $\pm 1\%FS\pm 1$ digit 4 $\leq\chi$ \leq 20L/min $\pm 5\%RD\pm 1$ digit	0.5 $\leq\chi$ <5L/min $\pm 1\%FS\pm 1$ digit 5 $\leq\chi$ \leq 50L/min $\pm 5\%RD\pm 1$ digit	
Pressure characteristics 0 to 0.5 MPa *4		0.2 $\leq\chi$ <4L/min $\pm 1\%FS\pm 1$ digit 4 $\leq\chi$ \leq 20L/min $\pm 5\%RD\pm 1$ digit	0.5 $\leq\chi$ <5L/min $\pm 1\%FS\pm 1$ digit 5 $\leq\chi$ \leq 50L/min $\pm 5\%RD\pm 1$ digit	
Operating temperature range		0 to 50°C		
Storage temperature range		-20 to +50°C		
Operating humidity range		10 to 90%RH (condensation not allowed)		
Operating pressure range		0 to 0.5MPa		
Pressure resistance		0.7MPa		
Connection aperture		1/4 Rc		
Body material		PBT (polybutylene terephthalate)		
Case material		ABS		
Mounting position		Horizontal mounting. (Meter section must not face down.) If this device is mounted vertically, it may drift causing an error while the flowrate is zero. For details, contact Yamatake.		
Rated voltage		12 to 24Vdc		
Supply voltage range		10.8 to 26.4V		
Current consumption		100mA max.		
Sampling cycle		100ms \pm 10ms		
Display	Flowrate display	7-segment LED 4-digit/selectable between instantaneous and integrated flowrates		
	Instantaneous flowrate	Min. display	0.1 L/min (0.05 L/min) *6	0.1 L/min
		Resolution	0.1 L/min (0.05 L/min) *6	0.1 L/min
	Integrated flowrate	Display unit	1 L	
		Display range	0 to 99999999	
		Data storage	Data is written to memory every 10min. (Integrated value can be reset by operating the keys or external contact input.)	
Status display		Instantaneous flowrate display LED/Integrated flowrate display LED/Event display LED		
Output signal (instantaneous flowrate output)		0 to 5Vdc (allowable load resistance 10k Ω min.) 5.7V or more is not output even if the output exceeds the output range.		

Item		CMS0020	CMS0002
Output scaling function *7		Selectable from 0 to 2, 0 to 5, 0 to 20, 0 to 20L/min. Factory setting: 0 to 20L/min	Selectable from 0 to 10, 0 to 20, 0 to 30, 0 to 50L/min. Factory setting: 0 to 50L/min
Event output	Number of points	2	
	Output	Open collector (rated 30Vdc, 50mA)	
	Description of event functions	For details, see attached tables 1 and 2. Specify from among instantaneous flowrate upper limit/lower limit, integrated flowrate countup, reverse-integrated flowrate countdown, integration pulse output (event 2 only), flowrate data serial output (event 1).	
External input	Number of points	1 (input dedicated to reset of integrated count)	
	Input specifications	Circuit type on other side: No-voltage contact or open collector Contact OFF terminal voltage: 4.5±1V Contact ON terminal current: approx. 0.5mA (current flowing to contact) Allowable ON contact resistance: 250Ω max. Allowable OFF contact resistance: 100kΩ min. Allowable ON residual voltage: 0.8V max.(open collector on other side) Allowable OFF leakage current: 50μA max. (open collector on other side)	
Serial data output		Open collector (rated 30Vdc, 50mA)	
Gas type switching function		Air/Nitrogen, Argon, Carbon dioxide (CO ₂) Select the gas type using the keys on the body	
Gas type setup function		Gas type conversion factor; set in the range between 0.10 and 8.00 using the keys on the body	
Electrical connection		Harness with a special connector (optional)	
Applicable standards		Compliant with the CE marking EN61326-1:1997 A1:1998	
Mass		Approx. 280 g	

*1: A flowrate range used in air. This product is provided with a gas type selecting function which enables you to select the desired gas type using the keys on the body.

See "Maximum measured flowrate and output voltage for each gas type" on page 34.

Also a scaling changing function is provided enabling you to change the scaling of 0 to 5V output using the keys on the body.

*2: For the gases not listed in this table, some of them are applicable using the gas type conversion factor function. For details, contact Yamatake.

*3: The ambient temperature during adjustment is 25°C.

*4: Amount of change on a flowrate referenced to 20°C under atmospheric pressure.

*5: Amount of change on a flowrate referenced to atmospheric pressure at 20°C.

*6: When the gas type conversion factor has been set to 0.10 to 0.49.

*7: The scaling of the 0 to 5V voltage output can be changed using the keys on the body. When the gas type is changed, the range of flowrate measurement changes as specified in "maximum measured flowrate for each gas type" in the table. However, this function produces an output by the preset scaling regardless of what gas type has been selected.

- The following table shows the maximum measured flowrate and output voltage for each gas type: (The output at the maximum measured flowrate is indicated as the voltage.)

Gas type	CMS9500			CMS0002		
	Maximum measured flowrate [mL/min]	Output voltage [V]	Conversion factor	Maximum measured flowrate [L/min]	Output voltage [V]	Conversion factor
N (Air/Nitrogen)	500	5	1.0	2	5	1.0
A (Argon)	500	5	1.045	2	5	1.045
C (Carbon dioxide)	250	2.5	0.522	1	2.5	0.549
S (Oxygen)	500	5	1.0	2	5	1.0
G (City gas 13A)	400	4	0.822	1.5	3.75	0.814
M (Methane)	500	5	0.99	2	5	0.977
L (Propane)	140	1.4	0.284	0.5	1.25	0.284
B (Butane)	100	1	0.195	0.4	1	0.198
User setup	(Note 1)	5	(Note 2)	(Note 1)	5	(Note 2)

Gas type	CMS0005			CMS0020		
	Maximum measured flowrate [L/min]	Output voltage [V]	Conversion factor	Maximum measured flowrate [L/min]	Output voltage [V]	Conversion factor
N (Air/Nitrogen)	5	5	1.0	20	5	1.0
A (Argon)	5	5	1.182	20	5	1.0
C (Carbon dioxide)	3.3	3.3	0.668	10	2.5	0.555
S (Oxygen)	5	5	1.0	20	5	1.0
G (City gas 13A)	4.5	4.5	0.783	15	3.75	0.828
M (Methane)	5	5	0.925	20	5	1.0
L (Propane)	1.7	1.7	0.343	5	1.25	0.28
B (Butane)	1.25	1.25	0.25	5	1.25	0.255
User setup	(Note 1)	5	(Note 2)	(Note 1)	5	(Note 2)

Gas type	CMS0050			CMS0200		
	Maximum measured flowrate [L/min]	Output voltage [V]	Conversion factor	Maximum measured flowrate [L/min]	Output voltage [V]	Conversion factor
N (Air/Nitrogen)	50	5	1.0	200	5	1.0
A (Argon)	50	5	1.0	200	5	1.0
C (Carbon dioxide)	25	2.5	0.555	100	2.5	0.555
S (Oxygen)	50	5	1.0	200	5	1.0
G (City gas 13A)	40	4	0.828	150	3.75	0.828
M (Methane)	50	5	1.0	200	5	1.0
L (Propane)	14	1.4	0.28	50	1.25	0.28
B (Butane)	12	1.2	0.255	50	1.25	0.255
User setup	(Note 1)	5	(Note 2)	(Note 1)	5	(Note 2)

Gas type	CMS0050		
	Maximum measured flowrate [L/min]	Output voltage [V]	Conversion factor
N (Air/Nitrogen)	500	5	1.0
A (Argon)	500	5	1.0
C (Carbon dioxide)	250	2.5	0.555
S (Oxygen)	500	5	1.0
G (City gas 13A)	400	4	0.828
M (Methane)	500	5	1.0
L (Propane)	140	1.4	0.28
B (Butane)	120	1.2	0.255
User setup	(Note 1)	5	(Note 2)

(Note 1): Flowrate set by the user is as follows:

CMS9500: 500 X gas type conversion factor

CMS0002: 2 X gas type conversion factor

CMS0005: 5 X gas type conversion factor

CMS0020: 20 X gas type conversion factor

CMS0050: 50 X gas type conversion factor

CMS0200: 200 X gas type conversion factor

CMS0500: 500 X gas type conversion factor

However, the 7-segment indication cannot show a value greater than ~~2560~~.

(The position of the decimal point differs depending on the mode.)

(Note 2): The gas type conversion factor can be set by the user within the range 0.10 to 8.00.

■ External dimensions

- Resin model CMS0020/0050 with display

Unit: mm

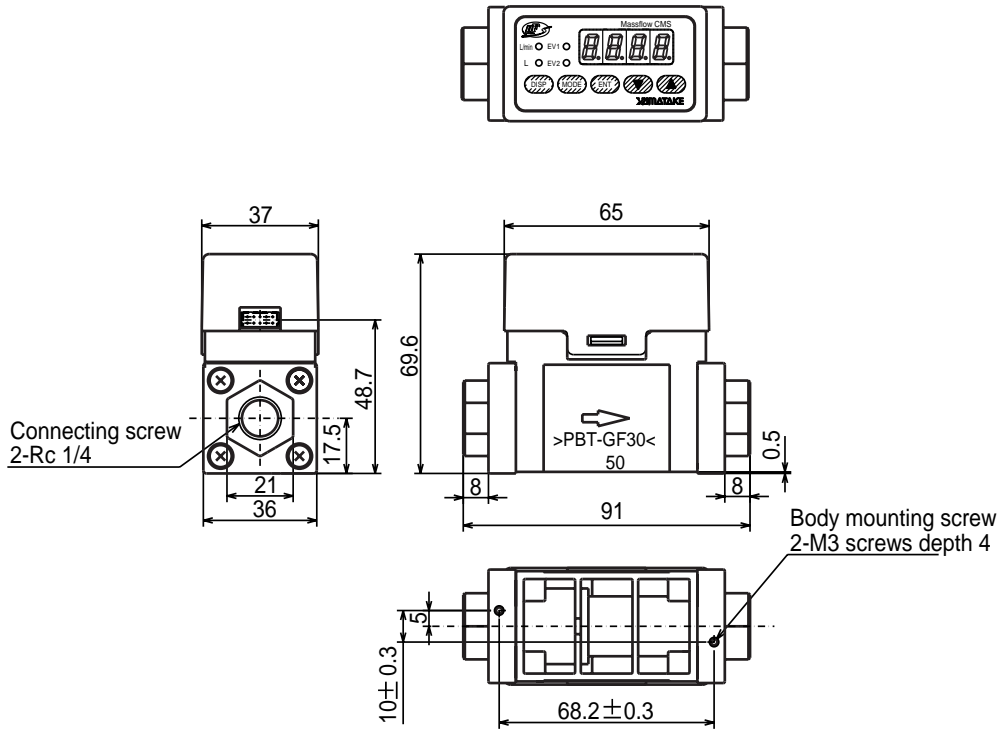

- Resin model CMS0020/0050 without display

Unit: mm

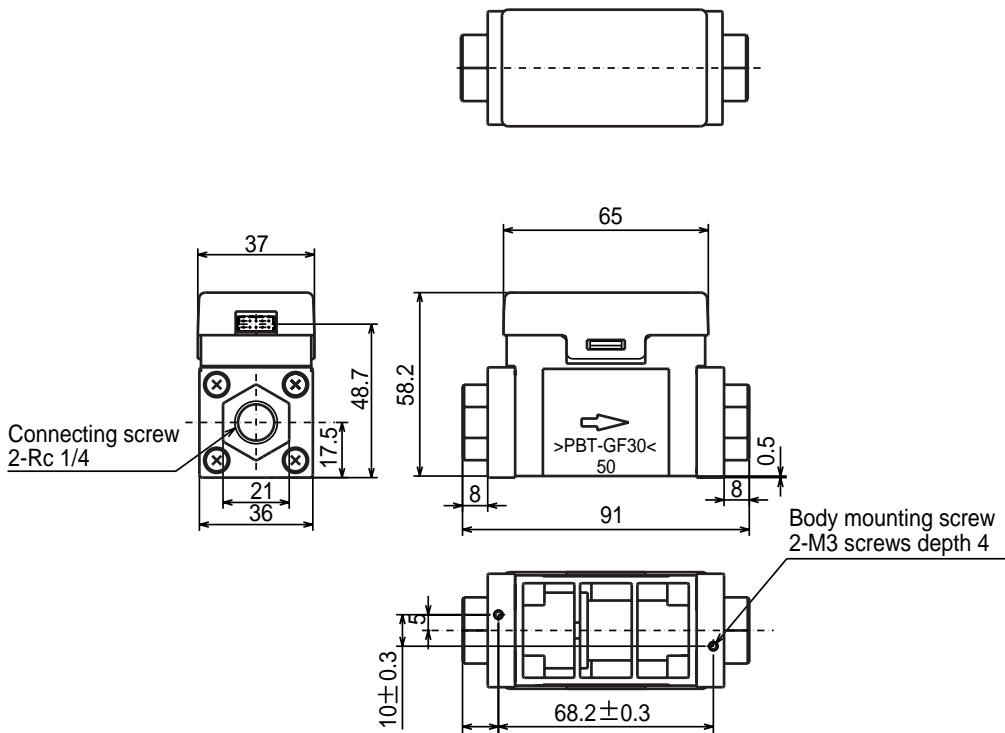

● SUS model CMS9500/0002/0005/0020/0050

Unit: mm

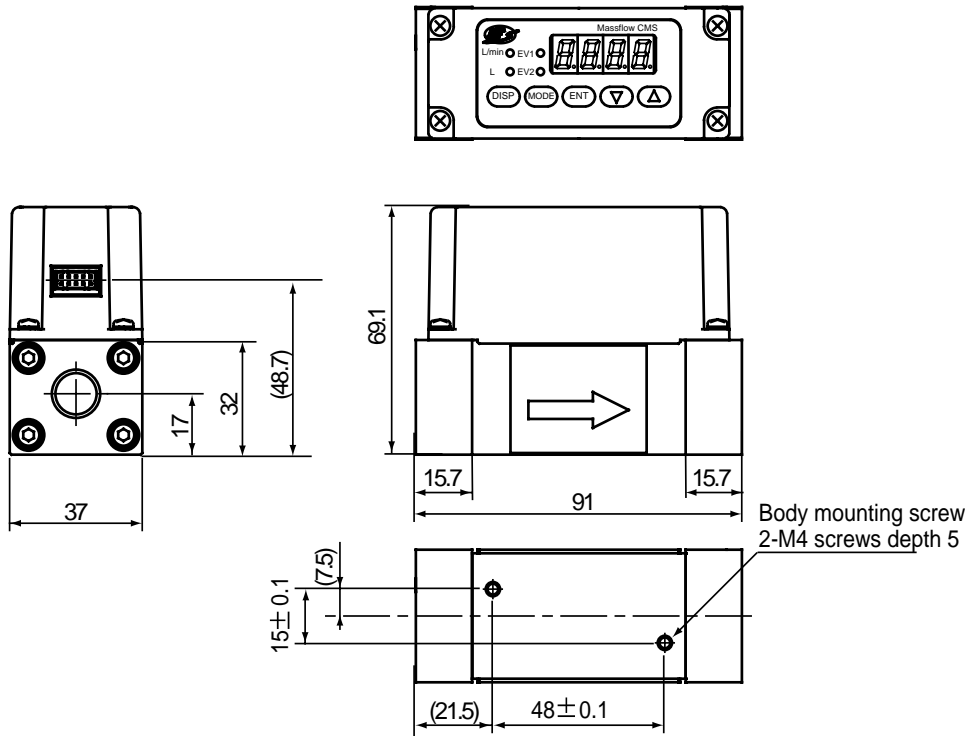

● SUS model CMS0200

Unit: mm

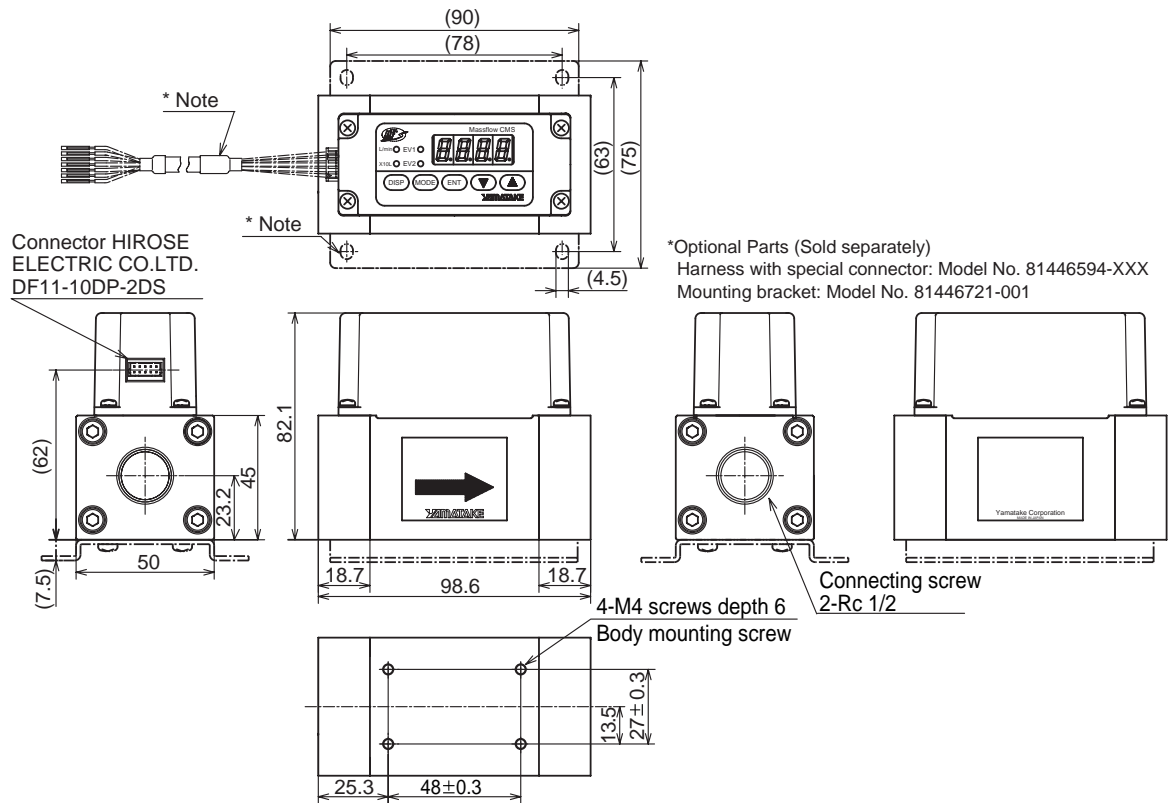

● SUS model CMS0500

Unit: mm

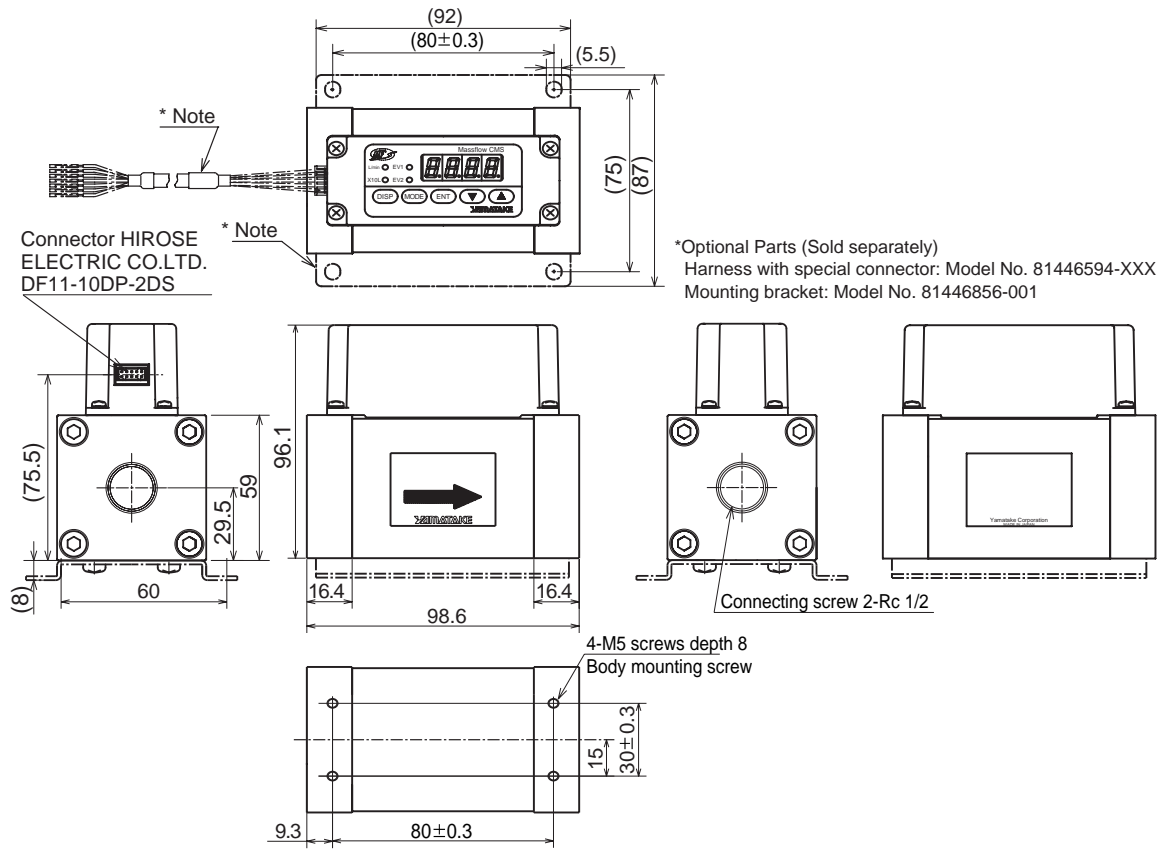

● SUS316 model CMS9500/0002/0005/0020/0050

Unit: mm

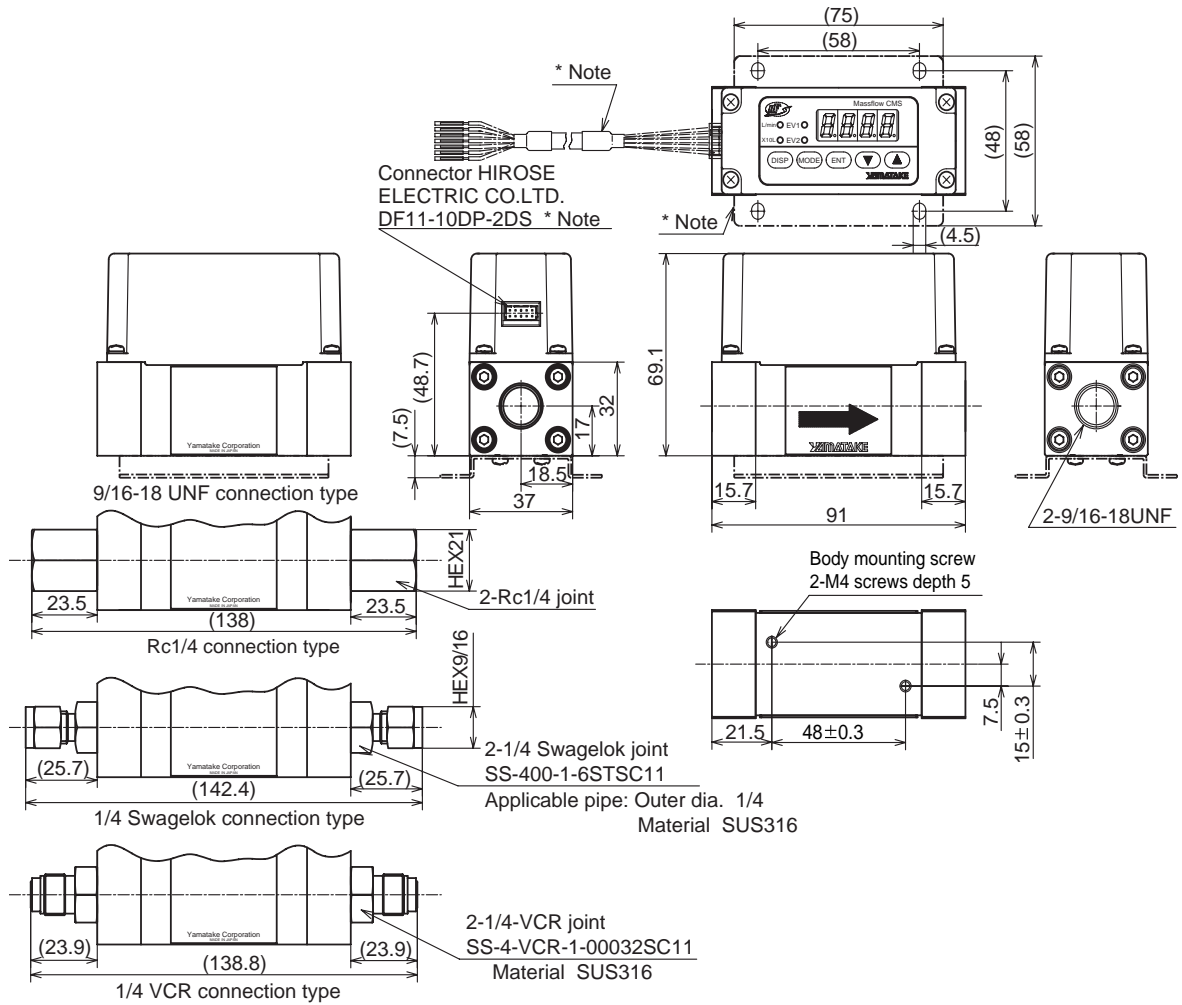

*Optional Parts (Sold separately)
 Harness with special connector: Model No. 81446594-XXX
 Mounting bracket: Model No. 81446628-001

● SUS316 model CMS0200

Unit: mm

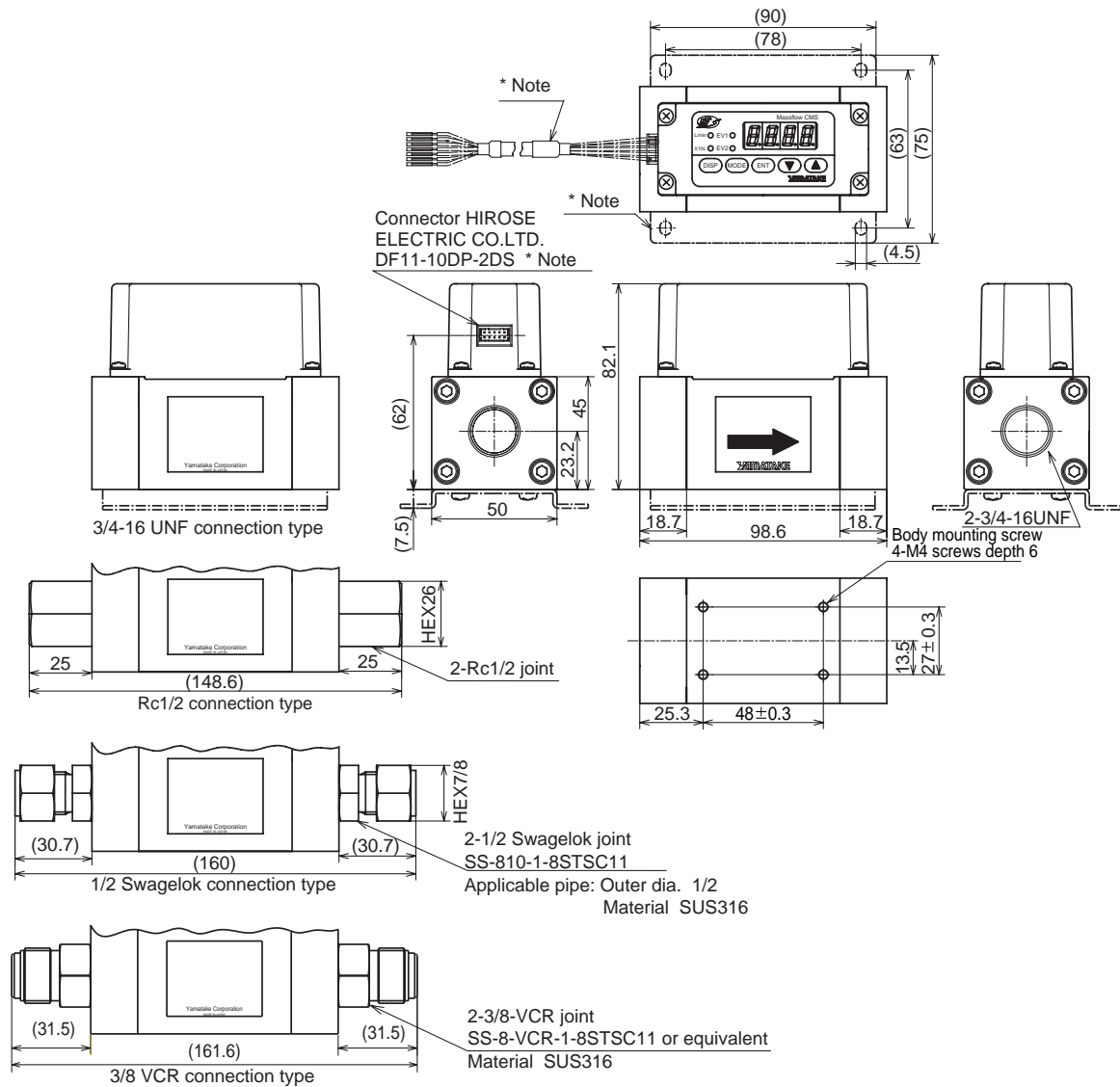

*Optional Parts (Sold separately)
 Harness with special connector: Model No. 81446594-XXX
 Mounting bracket: Model No. 81446721-001

● SUS316 model CMS0500

Unit: mm

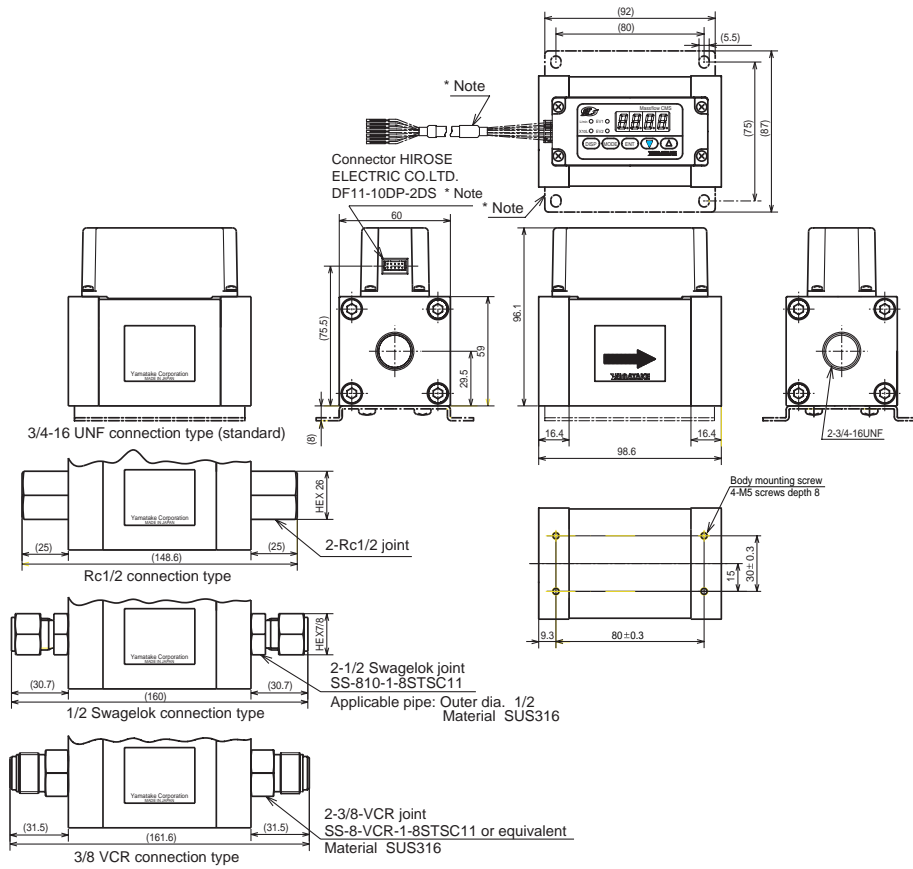

*Optional Parts (Sold separately)
 Harness with special connector: Model No. 81446594-XXX
 Mounting bracket: Model No. 81446856-001

● Mounting bracket 81446628-001 (CMS9500/0002/0005/0020/0050)

Unit: mm

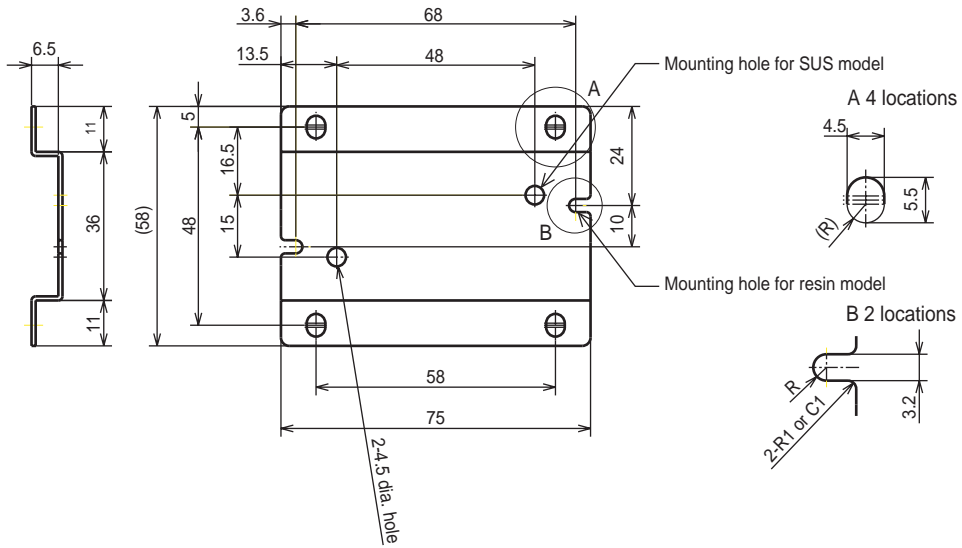

● Mounting bracket 81446721-001 (CMS0200)

Unit: mm

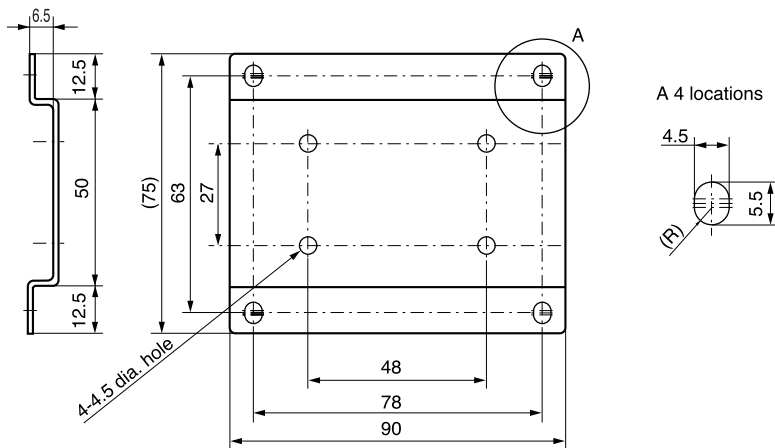

● Mounting bracket 81446856-001 (CMS0500)

Unit: mm

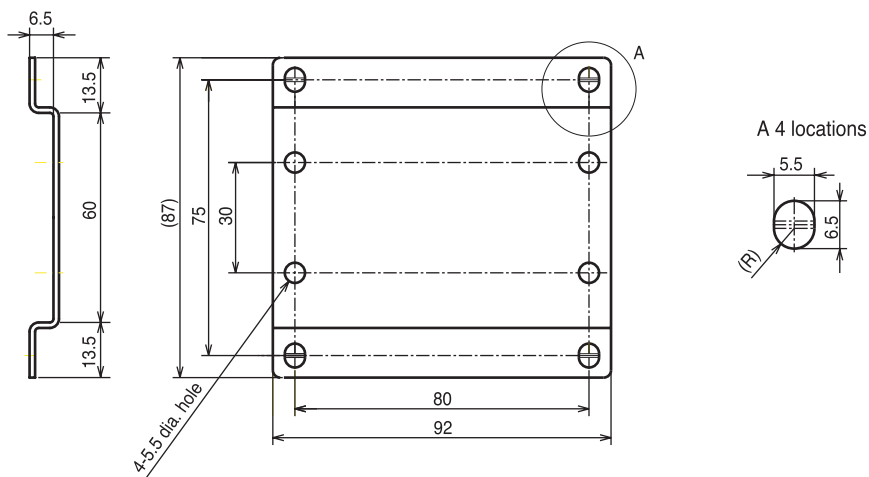

■ Pressure loss

The graph below shows the data in air.

The values for the gases other than air can be obtained by multiplying the specific gravities shown in the table below.

Specific gravity (with air as 1.0)	
Argon	1.38
Carbon dioxide	1.53
Oxygen	1.11
City gas 13A (limited to LNG)	0.64
Methane 100%	0.56
Propane 100%	1.56
Butane	2.08

Example: On the conditions that the model is CMS9500, the primary pressure is 100 kPa, and the flowrate is 500 mL/min, the pressure loss for argon is calculated as follows:

From the graph of CMS9500, you know the pressure loss is about 4.3 Pa when the primary pressure is 100 kPa and the flowrate is 500 mL/min.

Multiply this value by 1.38, the specific gravity of argon, and the result is $4.3 \times 1.38 = 5.934$ Pa.

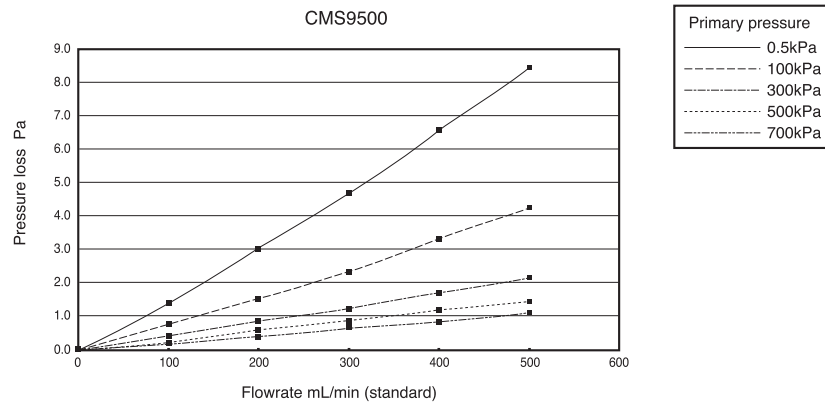

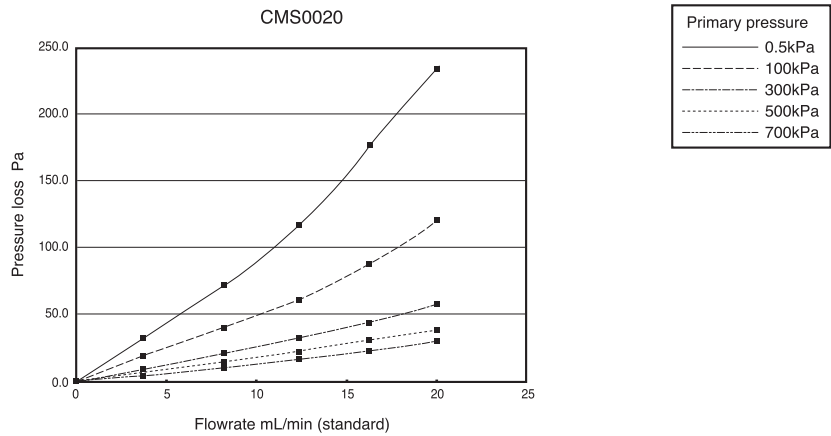
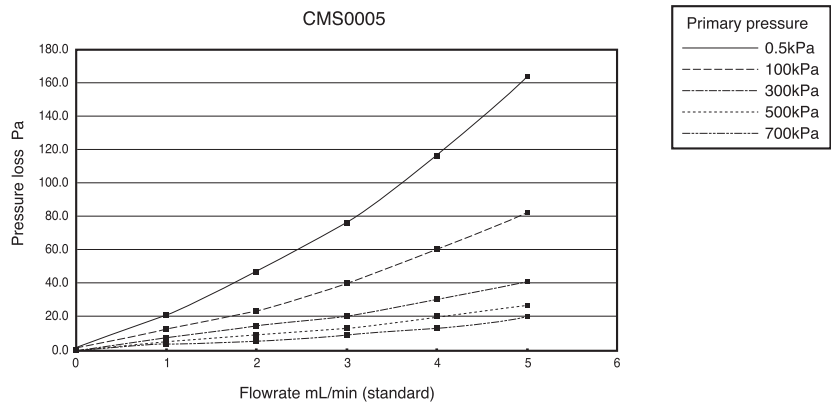
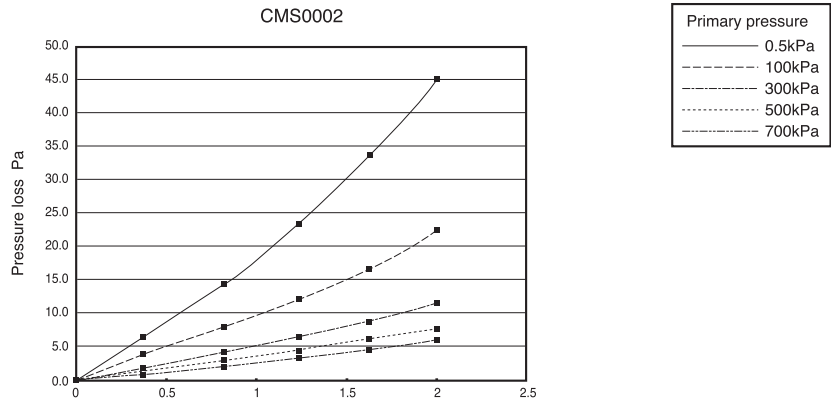

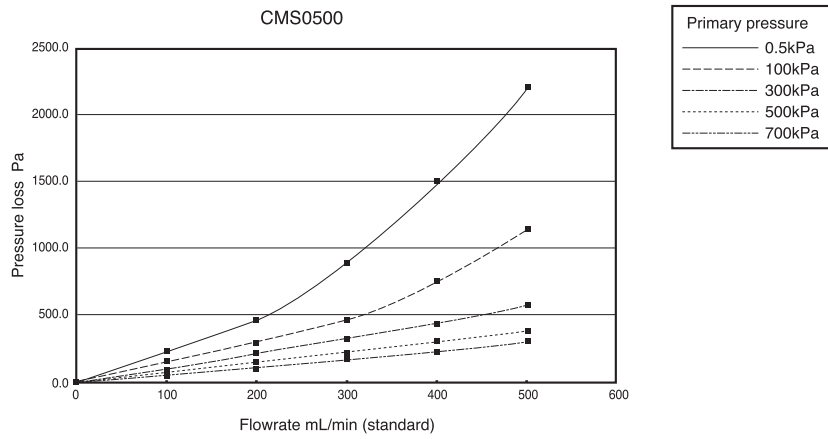
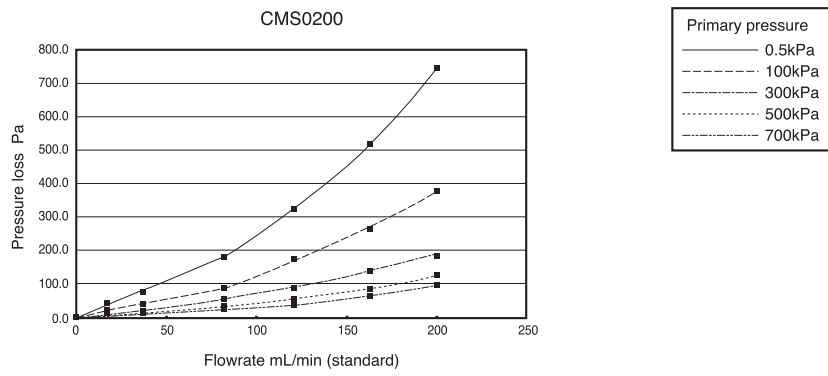
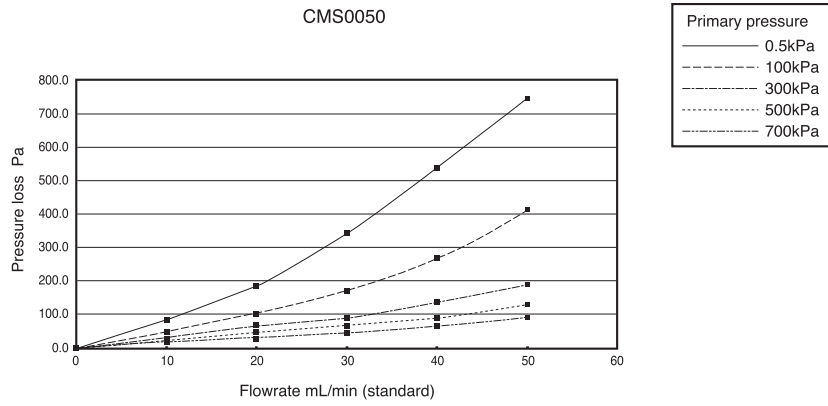

YAMATAKE

Yamatake Corporation
Advanced Automation Company
International Business Headquarters

Totate International Building

2-12-19 Shibuya Shibuya-ku

Tokyo 150-8316 Japan

URL: <http://www.yamatake.com>

This has been printed on recycled paper. (01)

Specifications are subject to change without notice.

Printed in Japan.

1st Edition: Issued in Nov., 2001(C)

2nd Edition: Issued in Oct., 2003(W)