



Digital Mass Flow Controller

CMQ9200 / 9500 / 0002 / 0005 / 0020 / 0050

User's Manual



Thank you for purchasing the Digital Mass Flow Controller CMQ Series. This manual contains information for ensuring correct use of the CMQ Series. It also provides necessary information for installation, maintenance, and troubleshooting. This manual should be read by those who design and maintain devices that use the CMQ Series. Be sure to keep this manual nearby for handy reference.

RESTRICTIONS ON USE

This product has been designed, developed and manufactured for general-purpose application in machinery and equipment.

Accordingly, when used in applications outlined below, special care should be taken to implement a fail-safe and/or redundant design concept as well as a periodic maintenance program.

- Safety devices for plant worker protection
- Start/stop control devices for transportation and material handling machines
- Aeronautical/aerospace machines
- Control devices for nuclear reactors

Never use this product in applications where human safety may be put at risk.

REQUEST

Ensure that this User's Manual is handed over to the user before the product is used.

Copying or duplicating this User's Manual in part or in whole is forbidden. The information and specifications in this User's Manual are subject to change without notice.

Considerable effort has been made to ensure that this User's Manual is free from inaccuracies and omissions.

If you should find any inaccuracies or omissions, please contact Yamatake Corporation.

In no event is Yamatake Corporation liable to anyone for any indirect, special or consequential damages as a result of using this product.

©2001 Yamatake Corporation ALL RIGHTS RESERVED

The μ F logo is a trademark of Yamatake Corporation.

Micro Flow Sensor, CMQ, SDC20/21, and WN790A are trademarks of Yamatake Corporation.

SAFETY PRECAUTIONS

■ About Icons

Safety precautions are for ensuring safe and correct use of this product, and for preventing injury to the operator and other people or damage to property. You must observe these safety precautions. The safety precautions described in this manual are indicated by various icons.

As the following describes the icons and their meanings, be sure to read and understand the descriptions before reading this manual:



WARNING

Warnings are indicated when mishandling this product might result in death or serious injury to the user.



CAUTION

Cautions are indicated when mishandling this product might result in minor injury to the user, or only physical damage to this product.

■ Examples

	<p>Triangles warn the user of a possible danger that may be caused by wrongful operation or misuse of this product.</p> <p>These icons graphically represent the actual danger. (The example on the left warns the user of the danger of electrical shock.)</p>
	<p>White circles with a diagonal bar notify the user that specific actions are prohibited to prevent possible danger.</p> <p>These icons graphically represent the actual prohibited action. (The example on the left notifies the user that disassembly is prohibited.)</p>
	<p>Black filled-in circles instruct the user to carry out a specific obligatory action to prevent possible danger.</p> <p>These icons graphically represent the actual action to be carried out. (The example on the left instructs the user to remove the plug from the outlet.)</p>

WARNING



Never allow gases that are within explosive limits to pass through this controller.

Doing so might result in explosion accidents.



Never use parts whose gas-contacting sections have not been treated (SUS-treated) to be oil-inhibiting for oxygen gas. Doing so might cause ignition. Even if gas-contacting sections have been treated to be oil-inhibiting and have been used for gases other than oxygen, never use them for oxygen gas.

CAUTION



Prevent foreign matter from entering the device.

If the rust, water droplet, oil mist or dust in the piping flows into the device, measurement error might occur and result in damaging the device. If there is a possibility that any foreign matter flows into the device, provide a filter, strainer or mist trap capable of eliminating more than 0.1 μ m foreign matter at the upstream, and periodically inspect and replace the filter.



When the device is used for air/fuel ratio control, take the necessary countermeasures with the instrumentation to prevent the occurrence of backfire and to avoid any influence to the device even if backfiring has occurred. Pressure increase in the piping or fire caused by the backfire of the burner could damage the device.



Measurement or control of hydrogen or helium gas cannot be done. Use a dedicated model for hydrogen and helium gases.



Use this device within the operating differential pressure range. Also, do not apply pressure outside the pressure resistance range. Doing so might damage this device.



This device is not provided with the capability of completely closing the valve. If the valve must be completely closed, provide a shutoff valve separately. When an external valve is closed, must make the valve stand by by fully closing with either of the following methods:

- Make the flowrate to zero.
- Set the operation mode to the fully closed mode.

If this valve is maintained in normal control condition despite of closing the external shutoff valve (zero flowrate), large excess flowrate will instantly flow when the external shutoff valve is opened. The AL81 alarm (sensor safety circuit activated) will be operated by this excess flowrate.

When the sensor safety circuit is activated, flowrate measurement and control cannot be performed unless the power is once turned off.

The Role of This Manual

In all, two manuals have been prepared for the CMQ9200 / 9500 / 0002 / 0005 / 0020 / 0050. Read the manual according to your specific requirements. The following lists all the manuals that accompany the CMQ series gives a brief outline of the manual:

If you do not have the required manual, contact Yamatake or your dealer.

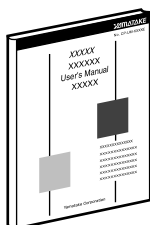

Digital Mass Flow Controller CMQ9200 / 9500 / 0002 / 0005 / 0020 / 0050 Manual No. CP-SP-112E

This manual.

First-time users of the CMQ9200 / 9500 / 0002 / 0005 / 0020 / 0050, and those in charge of maintenance and hardware design for assembling the CMQ9200 / 9500 / 0002 / 0005 / 0020 / 0050 in instrumentation should read this manual.

This manual describes an outline of the product, how to install and wire to assemble the product in instrumentation, operation methods, inspection and maintenance, how to remedy trouble, and the product's hardware specifications.

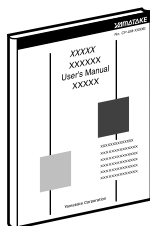

Digital Mass Flow Controller CMQ Series Communications Manual No. CP-SP-1071E

Those using the communications functions of the CMQ series should read this manual.

This manual describes an outline of communications, wiring, communications procedures, a list of CMQ series communications data, how to remedy trouble, and communications specifications.

Organization of This User's Manual

This manual is organized as follows:

Chapter 1. INTRODUCTION

This chapter briefly describes this device, its features and the model selection guide.

Chapter 2. NAMES AND FUNCTIONS OF PARTS

This chapter describes the NAMES AND FUNCTIONS OF PARTS on this device.

Chapter 3. MOUNTING AND WIRING

This chapter describes installation, mounting, wiring and initial settings on this device.

Chapter 4. BASIC OPERATION

This chapter describes the basic operations for using this device.

Chapter 5. APPLICATION OPERATION

This chapter describes how to set the functions and parameters on this device.

Chapter 6. MAINTENANCE AND TROUBLESHOOTING

This chapter describes how to investigate and remedy trouble that may occur during operation of this device.

Chapter 7. SPECIFICATIONS

This chapter describes the specifications and external dimensions of this device.

Contents

SAFETY PRECAUTIONS

The Role of This Manual

Organization of This User's Manual

Conventions Used in This Manual

Chapter 1. INTRODUCTION

- Introduction..... 1-1
- Features 1-1
- Functions 1-2
- Model selection guide..... 1-4

Chapter 2. NAMES AND FUNCTIONS OF PARTS

Chapter 3. MOUNTING AND WIRING

- Mounting..... 3-2
- Wiring..... 3-5

Chapter 4. BASIC OPERATION

- 4-1 Switching Displays 4-1
- 4-2 Selecting the Operating Mode 4-3
- 4-3 Setting the Flowrate 4-4
 - Procedure for changing digital instantaneous SP..... 4-4
 - Procedure for changing analog instantaneous SP..... 4-6

Chapter 5. APPLICATION OPERATION

- 5-1 Function Setup 5-1
- 5-2 Parameter Setup..... 5-6

Chapter 6. MAINTENANCE AND TROUBLESHOOTING



- Alarm code display 6-1
- Other trouble..... 6-1

Chapter 7. SPECIFICATIONS

- Specifications..... 7-1
- Relationship between flowrate when valve is fully open and 7-7
differential pressure
- Full scale flowrate and resolution at flowrate range change 7-8
- External dimensions..... 7-12

Conventions Used in This Manual

The following conventions are used in this manual:

-  **Handling Precautions** : Handling Precautions indicate items that the user should pay attention to when handling the **CMQ sereis**.
-  **Note** : Notes indicate useful information that the user might benefit by knowing.
- (1), (2), (3) : The numbers with the parenthesis indicate steps in a sequence or indicate corresponding parts in an explanation.
-  **FF** : This indicates 7-segment indication on the setup display.
- “OK” lamp** : This indicates an LED lamp on the setup display.
- RUN key** : This indicates a key on the setup display.

Chapter 1. INTRODUCTION

■ Introduction

The CMQ series high performance, low priced digital mass flow controller has been developed for the general industrial market and features high speed, wide range flowrate control. The CMQ series integrates three component technologies: an ultra high speed response thermal flow velocity sensor, the μF (Micro Flow) sensor made using Yamatake proprietary technology, a proportional solenoid valve and advanced actuator control technology. Integrating these technologies achieves high speed control and low differential pressure control.

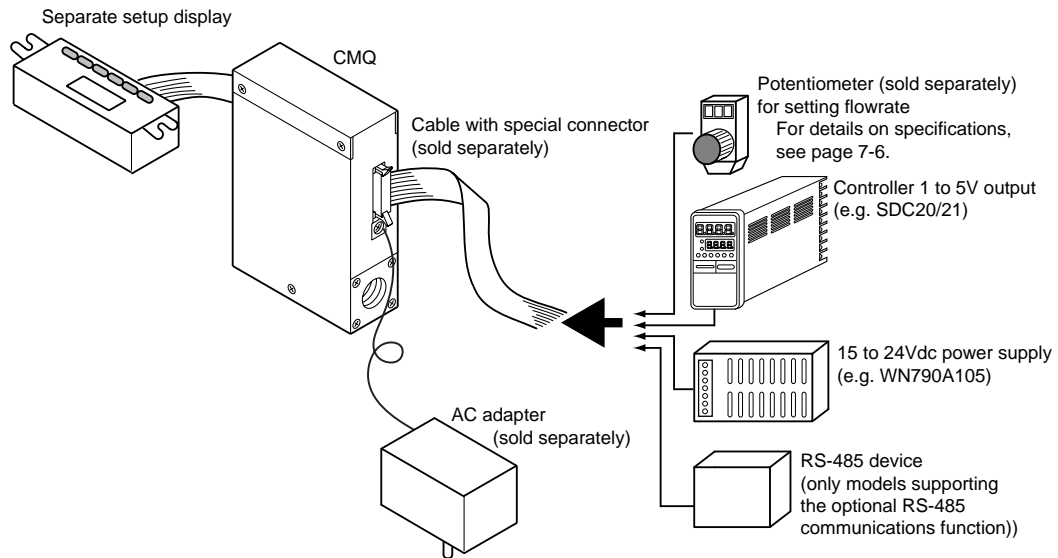

Device Configuration

■ Features

- High speed controllability
High speed response of 500ms or less
- Low differential pressure operation
The CMQ9500/0005 can be operated at a low differential pressure of 0.49 to 49kPa, and the CMQ9200/0002/0050/0020 can be operated at a low differential pressure of 0.98 to 294kPa.
- Wide control range
Wide control range of 1 to 100%FS
- Wide product line-up
Two models are provided: models with integrated display and models with separate display. On models with separate display, the display unit can be separated using a special 2m cable (provided) to enable remote display and operation.
- User-friendly
Runs on a general purpose single 15 to 24Vdc power supply. Also provided is a handy AC adapter for ensuring easy use in laboratory applications.
- Display orientation can be changed (models with integrated display only)
The orientation of the setup display can be rotated 180° to match the direction of gas flow, if the setup display faces the other way when it is mounted. It will result in the reading being upside-down.
- Wide range of functions
The functions given on the next page are standard functions.

■ Functions

The functions described on this page are provided as standard.

- **Multi-setup function**
Up to four preset flowrate settings can be instantaneously switched to by key operation or external switching input.
- **Gas type switching function**
The gas type to be used can be selected from the standard compatible gases by key operation.
- **Gas type setting function**
The user can set any gas type conversion factors to accommodate the gases other than standard compatible gases or mixed gases.
- **Valve forced open/close function**
The valve can be forcibly fully opened or fully closed by key operation or external switching input.
- **Control flowrate range setting function**
The setting and indication resolution can be improved by changing the control flowrate range to be 1/2 to 1/10 of the standard range (flowrate range at factory setting).
- **Slow start function**
Sudden changes in the control flowrate, when control is started or when the flowrate setting value is changed, can be suppressed.
The control speed can be changed in eight stages within the range from about 1 to 6 seconds.
- **Flowrate integration function**
CMQ9200/9500 : 0.01L in unit
CMQ0002/0005 : 0.1L in unit
CMQ0020/0050 : 1L in unit
The flowrate can be integrated up to eight digits (99,999,999 count).
(The display is switched in four digits at a time.)
The count can be reset by key operation or external switching input.
Integration start/stop/reset can be remote-controlled by external switching input.
After a reset by key operation, the integration calculation is started automatically. However, if a reset (contact ON) is carried out by external switching input, integration is resumed by the contact turning OFF.
- **“ALM”(alarm) lamp lighting/output/shut-off**
Alarm output can be set to upper and lower deviation of the setting flowrate and instantaneous flowrate. The alarm judgment delay time can also be set.
When a flowrate alarm occurs or when an alarm occurs during controller self-diagnostics, the valve can be forcibly fully closed or fully opened.

-
- **“EV1”, “EV2”(event) lamp lighting/output**
Two of the following event types can be output:
The output ON delay time can also be set (Delay cannot be set to integration pulse output).
 - Integration count up output (when the integration setting flowrate is exceeded.)
 - Integration pulse output (Pulse can be output for each integration display unit.)
 - OK output
 - Operating mode output (The four modes, control / fully open / control or fully open / fully closed, can be identified and output.)
 - **“OK” lamp lighting/output**
The **“OK” lamp** can be made to light when the control flowrate is within the “setting value \pm allowable range”. This function is very handy for verifying at a glance whether or not the new setting value is being followed properly when a setting value is changed. **“OK” lamp** output can also be used as an interlock signal for subsequent processes by assigning it to event output and loading it to a sequence program.
 - **Control dead zone setting function (valve operation stopping function)**
Valve operation can be stopped while the status of the instantaneous PV is within an OK judgment range. The user can set their own OK judgment range (dead zone width).
 - **Gas type external switching function**
Two types of gases set in advance (including one gas type conversion factor that is set by the user) can be switched by an external contact input.
 - **Control flowrate range external switching function**
Two types of control flowrate ranges set in advance can be switched by an external contact input.
 - **Automatic shut-off function**
The valve can be shut off automatically under the following conditions:
 - (1) When the integration count value reaches the setting value.
 - (2) When one of the alarms, including flowrate alarms, occurs.
 - ** Handling Precautions**
 - This device is not provided with the capability of completely closing the valve.
 - If the valve must be completely closed, provide a shut-off valve (sold separately).
 - **Automatic reset of integration count at start of control function**
Start of control and integration count reset can be carried out simultaneously by a single action (key operation or external switching input). Combining this function with the automatic shut-off function described above is handy for shutting the valve off when a fixed number of integration values have been counted repeatedly.

- Direct setup function

This function allows users to easily change the flowrate setup.

This function is useful when you frequently change setting values, for example, when you adjust the preset flowrate during trial operation.

- SP ramp control function

This function is used to set the set point change ramp level (the rate of change per second) to the constant value for the control start and flowrate set point change.

Two different types of ramps can be set, and there are the following 2 control modes:

- SP ramp control 1

In SP ramp-up: Ramp 1

In SP ramp-down: Ramp 2

- SP ramp control 2

In external contact OFF: Ramp 1

In external contact ON: Ramp 2

- Analog optional scaling function

This function is used to optionally change the flowrate at analog input/output 100% (5V) which was conventionally only full scale flowrate.

Model selection guide

Basic model No.	Standard control flow-rate range (nitrogen conversion value)	Display	Material of gas-contacting parts	Connection method	Gas type	Optional functions					Append- ed No.	Description	
						1	2	3	4	5			
CMQ												Digital mass flow controller	
	9200											2 to 200 mL/min (standard) Note 1	
	9500											0.004 to 0.500L/min (standard) Note 1	
	0002											0.02 to 2.00L/min (standard) Note 1	
	0005											0.04 to 5.00 L/min (standard) Note 1	
	0020											0.2 to 20.0 L/min (standard) Note 1	
	0050											0.4 to 50.0 L/min (standard) Note 1	
		B										Model with integrated display	
		C										Model with separate display	
			S									SUS316	
				U								9/16-18UNF (standard)	
				R								1/4Rc	
				S								1/4Swagelok	
				V								1/4VCR	
					N							Standard supported gas Note 2	
					S							Oxygen Note 2, 3	
						0						Without optional functions	
							0					Without optional functions	
								1				Models supporting RS-485 communications (CPL) function	
									0			Without optional functions	
										0		Without optional functions	
											1	Gas-contacting parts treated to be oil-inhibiting	
											0	Without optional functions	
											D	Inspection Certificate provided	
											Y	Complying with the traceability certification	
												0	Product version

Note 1: L/min (standard) indicates the volume flowrate (L/min) per minute converted to 20°C, one atmosphere.

The reference temperature can also be changed to 0°C and 25°C at **[- 1 9]** in the function setup.

Note 2: The air/nitrogen is set as a factory setting. The CMQ can be used for the following gases by changing the setting of the item **[- 1 8]** in the function setup:

(Argon, Carbon dioxide(CO₂), City gas 13A(LNG:Liquid Natural Gas), Methane100%, Propane100%, Butane100%)

The models for standard gases cannot be used for oxygen gas.

The controllable flowrate range varies according to the gas type. For details, see Chapter. 7 SPECIFICATIONS.

Note 3: When oxygen is selected as the gas type, oil-inhibiting on gas-contacting parts is standard (treatment costs are separate).

Chapter 2. NAMES AND FUNCTIONS OF PARTS

● Display

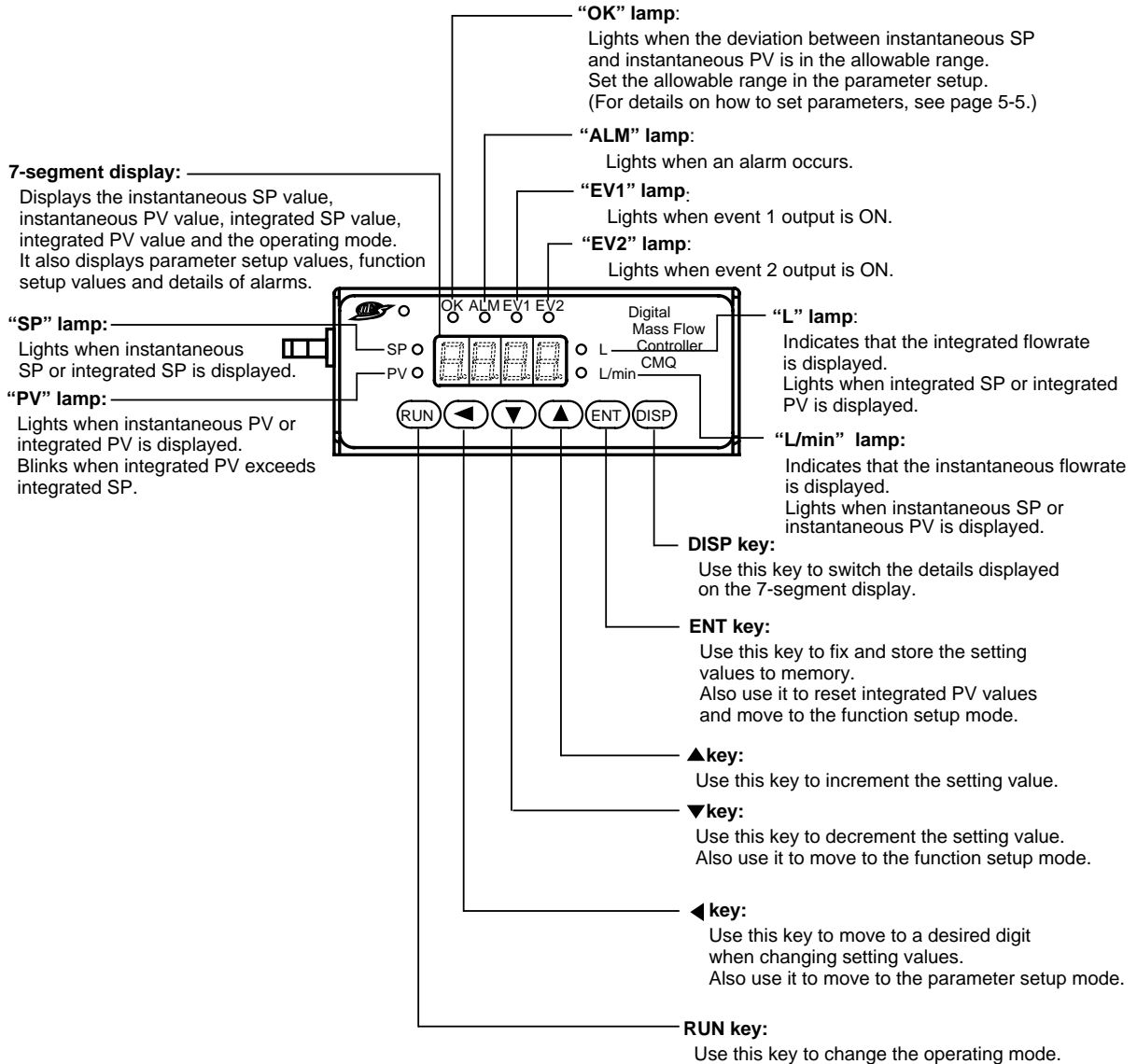

Note

Special terms used in this manual are defined as follows:

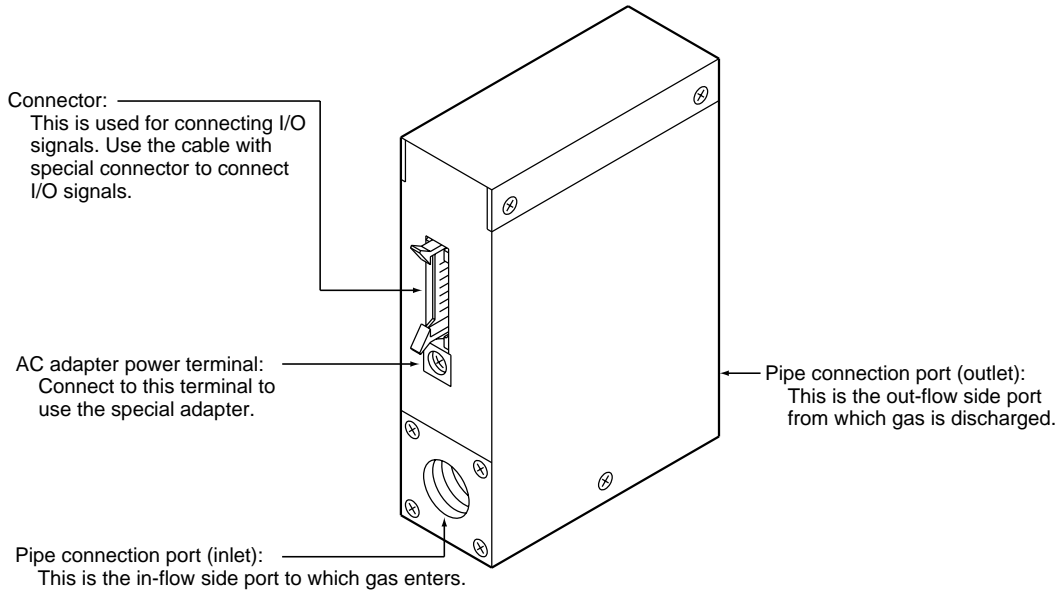

- SP : Set Point
- PV : Process Variable
- Instantaneous SP : Instantaneous setting flowrate
- Integrated SP : Integrated setting flowrate
- Instantaneous PV : Instantaneous flowrate
- Integrated PV : Integrated flowrate
- Operating mode : 3 modes (valve fully closed/valve control/valve fully open)

● Body











Chapter 3. MOUNTING AND WIRING

WARNING

-  Never allow gases that are within explosive limits to pass through this controller. Doing so might result in explosion accidents.
-  Never use parts whose gas-contacting sections have not been treated (SUS-treated) to be oil-inhibiting for oxygen gas. Doing so might cause ignition. Even if gas-contacting sections have been treated to be oil-inhibiting and have been used for gases other than oxygen, never use them for oxygen gas.

CAUTION

-  Prevent foreign matter from entering the device.
If the rust, water droplet, oil mist or dust in the piping flows into the device, measurement error might occur and result in damaging the device. If there is a possibility that any foreign matter flows into the device, provide a filter, strainer or mist trap capable of eliminating more than 0.1 μ m foreign matter at the upstream, and periodically inspect and replace the filter.
-  When the device is used for air/fuel ratio control, take the necessary countermeasures with the instrumentation to prevent the occurrence of backfire and to avoid any influence to the device even if backfiring has occurred. Pressure increase in the piping or fire caused by the backfire of the burner could damage the device.
-  Measurement or control of hydrogen or helium gas cannot be done. Use a dedicated model for hydrogen and helium gases.
-  Use this device within the operating differential pressure range. Also, do not apply pressure outside the pressure resistance range. Doing so might damage this device.
-  This device is not provided with the capability of completely closing the valve. If the valve must be completely closed, provide a shutoff valve separately. When an external valve is closed, must make the valve stand by by fully closing with either of the following methods:
 - Make the flowrate to zero.
 - Set the operation mode to the fully closed mode.If this valve is maintained in normal control condition despite of closing the external shutoff valve (zero flowrate), large excess flowrate will instantly flow when the external shutoff valve is opened. The AL81 alarm (sensor safety circuit activated) will be operated by this excess flowrate.
When the sensor safety circuit is activated, flowrate measurement and control cannot be performed unless the power is once turned off.
-  Before connecting pipes on Swagelok VCR connection types, check the precautions in the instruction manual provided by the connecting joint manufacturer.
When purchasing a separate connecting joint, use the following made by Swagelok Co., Ltd.

1/4Swagelok	: SS-400-1-6ST (standard)
	SS-400-1-6STSC11 (oil-inhibited)
1/4VCR	: SS-4-VCR-1-00032SC11
-  Pay attention to the following when using this flow meter (oil-inhibited part) in oxygen gas:
 - Piping should be carried out by a specialist skilled in handling oxygen gas.
 - Use oil-inhibited parts on this flow meter.
 - Be sure to remove dirt and burrs before you connect to this flow meter.
 - Install a filter at the upstream of this flow meter.
-  This device is a precision instrument. Do not drop it nor subject it to shock. Doing so might damage the device.

■ Mounting

● Installation site

Avoid mounting this device in the following locations:

- Locations subject to high and low temperature and humidity
- Locations whose atmospheres contain large amounts of dirt and dust, salt, conductive substances such as iron powder, water droplets, oil mist and organic solvents
- Locations subject to direct sunlight and rain
- Locations directly subject to mechanical vibration or shock
- Locations close to sources of electrical noise
- Locations where strong magnetic or electrical fields are generated

! Handling Precautions

- The device is not provided with the capability of complete closing the valve. If the valve must be completely closed, provide a shut-off valve (sold separately).

● Changing the display orientation (models with integrated display only)

The display can be turned 180°. If the setup display faces the other way when it is mounted, it will result in the reading being upside-down.

- Procedure
 - (1) Turn the power OFF.
 - (2) Temporarily remove the four countersunk screws for fastening the setup display.
 - (3) Lift up the setup display to remove it from the body, and turn it 180° counterclockwise.

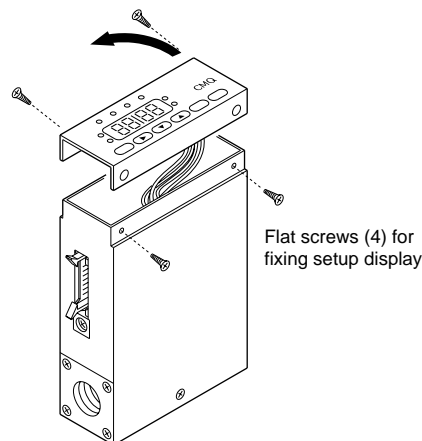

- (4) Return the setup display to the body, and fasten with the four countersunk screws removed in step (2).
- (5) To return the setup display to its original position on the body, turn it 180° clockwise.

! Handling Precautions

- Before changing the display orientation, be sure to turn the power OFF.
- Prevent foreign objects from falling inside the body when the setup display is removed. Failure to do so might cause trouble or malfunction.
- Do not remove the connectors used inside the body.

● Installing joints (UNF) connections

⚠ CAUTION

! When installing joints (UNF connections), fasten the bottom of the body in a vise gripped between rags to protect the finished surfaces, and turn the joint side to fasten in place.
This device may become damaged if the body bottom is not fastened.

When a standard type 9/16-18UNF connection is used, install the joint first (except when the pipe is directly connected).

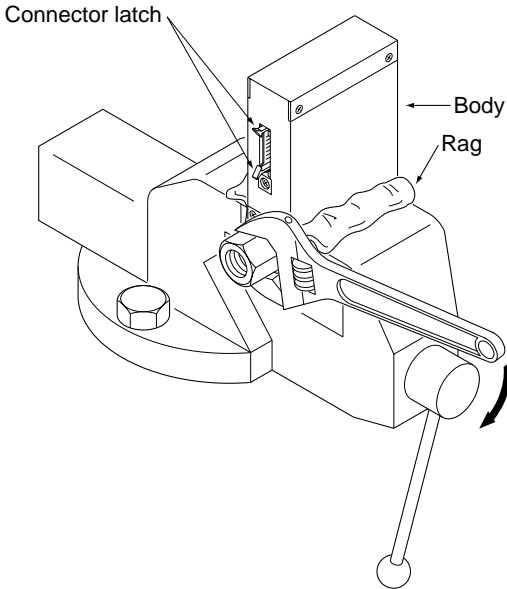

! Handling Precautions

- Do not hold the top part of the body with your hand. Doing so might deform the body.

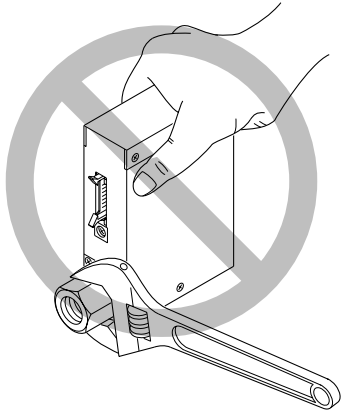

- Take special care not to damage the connector latch.

● Installation procedure

⚠ CAUTION



Firmly secure this device during installation to prevent vibration. Failure to do so might cause trouble.



Mount this device horizontally. Do not mount so that it is facing down. Doing so might cause error or trouble.

Install this device from the rear by the two M4 screws using the mounting holes on the base of the device.

Unit: mm

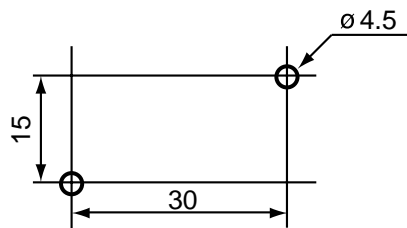

● Pipes

⚠ CAUTION



When connecting piping, fasten the hexagonal section of the joint, and turn the pipe side to connect. After connecting piping, check for any gas leaks.



In the case of 1/4Rc connections, take care not to coat with too much sealant. Dirt or burrs in the piping may also cause errors.

ⓘ Handling Precautions

- Make sure that the gas flows into the device in the direction indicated by the FLOW arrow on the body. Otherwise, the flowrate cannot be controlled correctly.
- Do not touch the pipe sections of oil-inhibited treated products with bare hands. Doing so will impair the treatment.
- Do not hold the top part of the body with your hand when connecting piping. Doing so might deform the body.

Make sure that the gas flows into the device in the direction indicated by the FLOW arrow on the body.

Fasten and connect pipes to the body using a spanner, wrench or similar tool on the hexagonal sections of the joints.

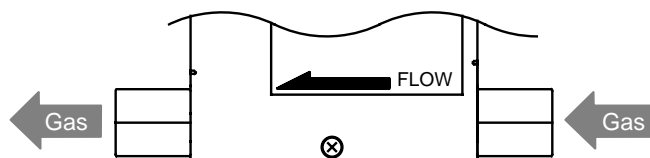

● Coating sealant (1/4Rc connection)

! Handling Precautions

Coat with an appropriate amount of sealant. Do not coat the top two threads of the screw. Remove any dirt or burrs from inside the pipes.

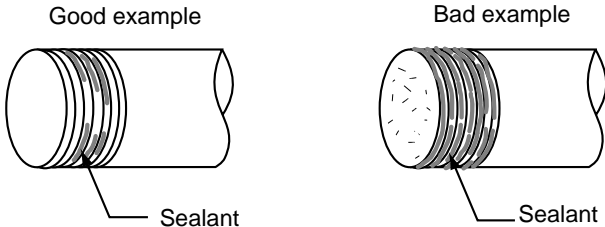

■ Wiring

! CAUTION

! Be sure to check that the wiring is correct before you turn the power ON. Incorrect wiring might cause damage or malfunction.

● Connector pin layout

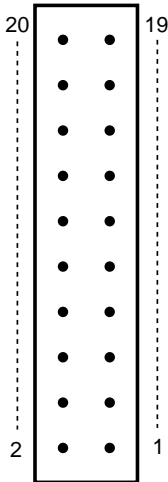

View from connector insertion side

Connector part No. (product side):
 HIF3BA-20PA-2.54DS
 Manufacturer: HIROSE ELECTRIC CO., LTD.

● Table of compatible connectors (all made by HIROSE ELECTRIC CO., LTD.)

Connector Type	Compatible Connector Part No.	Compatible Contact Part No	Compatible Lead
Contact pressure-connection type	HIF3BA-20D-2.54C	HIF3-2226SCC	AWG# 22 to # 26 (separate leads allowed)
Cable pressure-connection type	HIF3BA-20D-2.54R	Not required	AWG# 28 (flat cable only)

● Connector signal names

Pin number	Signal name	Description	Remarks
20	+5V (5mA max.)	5Vdc reference voltage output	5mA Max.
19	FLOW OUT	Instantaneous flow (PV) voltage output	0 to 5V or 1 to 5V output
18	A.GND	Analog ground	Analog signal common
17	FLOW SP INPUT	Instantaneous flow (SP) voltage input	0 to 5V or 1 to 5V input
16	MODE INPUT	External 3-stage switching input	3-stage switching input (OPEN/GND/5V)
15	DI3	External contact input 3	2-stage switching input (OPEN/GND)
14	DI2	External contact input 2	
13	DI1	External contact input 1	
12	EV2	Event output 2	Open collector non-insulated output
11	EV1	Event output 1	
10	ALM OUT	Alarm output	
9	D.GND	Digital ground	Digital signal common
8	RDB	RS-485 Communications RDB	Connect only on models with the communications function option. Do not connect on other models.
7	RDA	RS-485 Communications RDA	
6	SDB	RS-485 Communications SDB	
5	SDA	RS-485 Communications SDA	
4	POWER GND	Power supply ground	Connect two signals each in parallel to the power supply to reduce voltage drop caused by wiring resistance.
3	POWER GND	Power supply ground	
2	POWER (15 to 24V)	Power supply + (15 to 24Vdc)	
1	POWER (15 to 24V)	Power supply + (15 to 24Vdc)	

! Handling Precautions

POWER GND, Digital GND, Analog GND (pin Nos. 3, 4, 9 and 18) are all connected internally. (They are, however, not insulated.) Be sure to ground each of these individually. Malfunction may occur if they share the same ground lead.

Also, provide a power supply for the controller separate from the power supply for external devices (analog setup device, etc.), and insulate the power supplies from each other.

As each of the grounds on this device is not insulated as described above, wiring the grounds on a power supply that is shared with external devices might cause interference, resulting in trouble or malfunction.

● Wiring

- Power supply

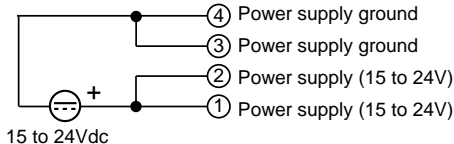

- External contact 3 input

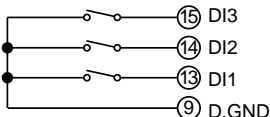

- External 3-stage switching input

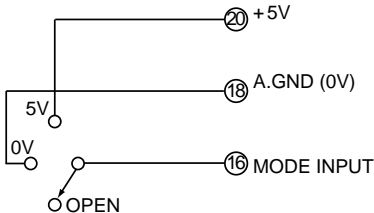

Operation of External 3-stage Switching Input

Input State of Pin No.16		OPEN	GND	5V
Assignment Function				
Switching of operating mode		Control	Fully closed	Fully open
Switching of SP No.		SP-0	SP-1	SP-2
Switching of integration operation		Continue count	Reset	Stop count
Switching of analog I/O voltage range	Input	Internal reference * 0 to 5V	External reference 0 to 5V	External reference 1 to 5V
	Output	0 to 5V	0 to 5V	1 to 5V

* " Internal reference" refers to use of the 5Vdc reference voltage pin (No.20) on this device, and is used when the setting value is used on an externally connected potentiometer.

Note

For details on how to assign external 3-stage switching input functions, see Chapter 5. APPLICATION OPERATION.

- Analog I/O

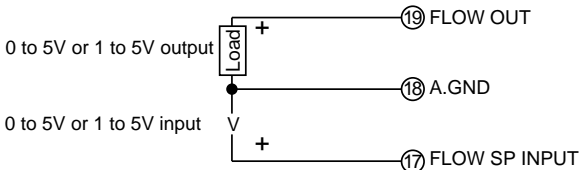

- Potentiometer

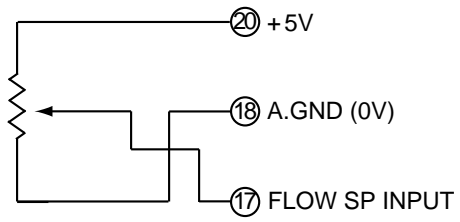

- Event output/Alarm output

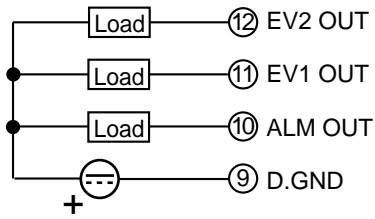

● Example of wiring

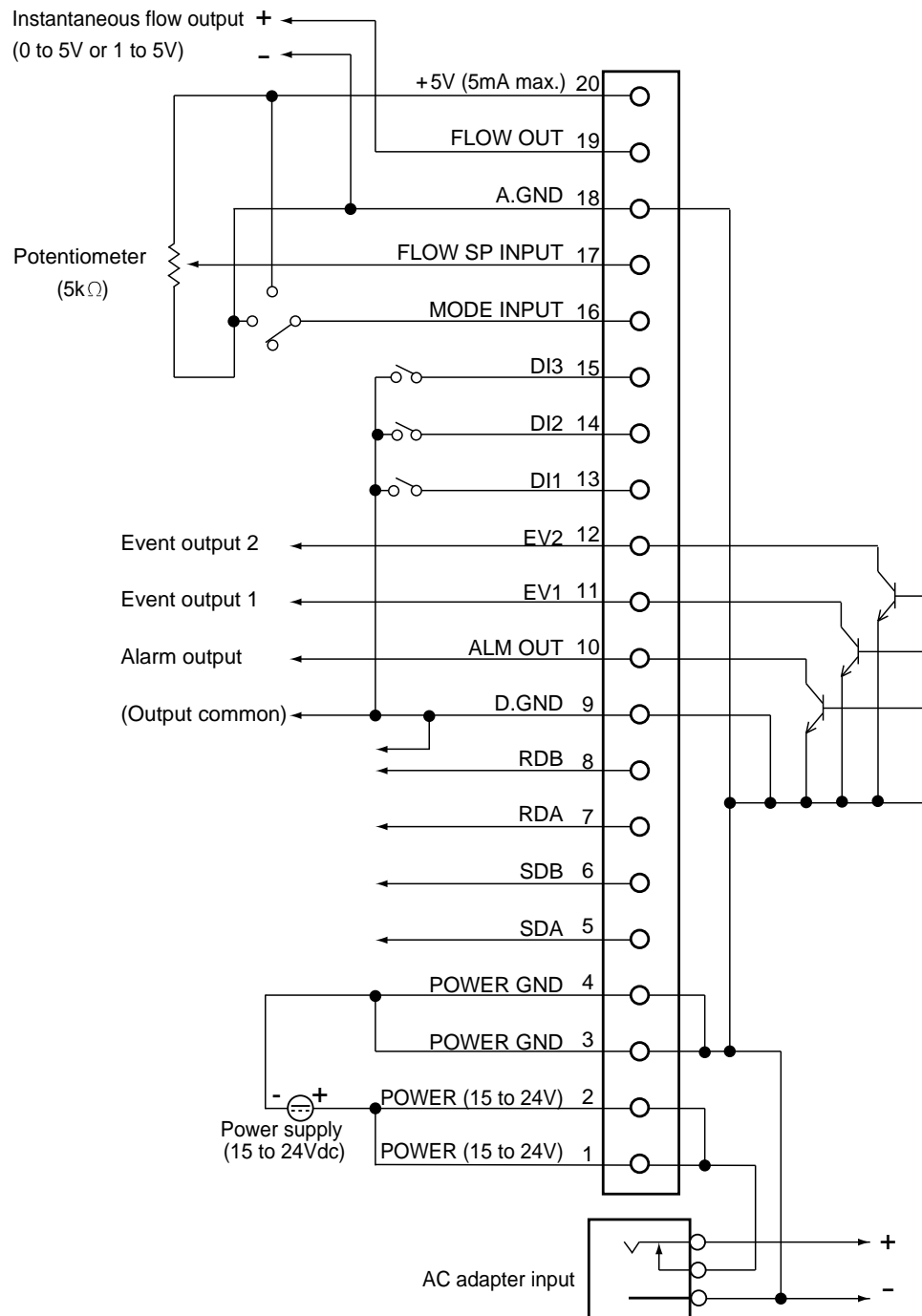

! Handling Precautions

- POWER GND, Digital GND, Analog GND are all connected internally. Though they are not insulated, be sure to ground each of these individually.
- Provide a power supply for the controller separate from the power supply for external devices (analog setup device, etc.), and insulate the power supplies from each other.
- Connect SDA, SDB, RDA and RDB only on models that support the communications function (optional). Do not connect on other models.
- When the AC adapter connector is inserted in the AC adapter power supply terminal, the power supply is automatically switched to the AC adapter side.

● **Connector terminal plate**

Sometimes two or more connections must be made to the same pin No. during wiring. In this case, use a connector terminal plate.

Note, however, that the user must prepare a 20-core cable for the connectors on the device and connector terminal plate.

Compatible connector: HIROSE ELECTRIC CO., LTD. HIF3BA-20D-2.54R

Recommended cable: Oki Electric Cable Company, Limited.

FLEX-S20-7/0.127-2651P or equivalent product

 **Note**

- Recommended Connector Terminal Plate

Manufacturer: Toyo Giken

Model: PCN-1H-20

Mounting connector

HIROSE ELECTRIC CO., LTD. HIF3BA-20PA-2.54DSA

Compatible connector (other side)

HIROSE ELECTRIC CO., LTD. HIF3BA-20D-2.54R

The following table shows the correspondence between connector pin Nos. and terminal plate Nos:

This terminal plate can be mounted directly on a DIN rail.

 **Handling Precautions**

The specifications of the recommended connector terminal plate are subject to change. Contact the manufacturer beforehand for details.

Pin No.	Terminal plate No.
20	B-10
19	A-10
18	B-9
17	A-9
16	B-8
15	A-8
14	B-7
13	A-7
12	B-6
11	A-6
10	B-5
9	A-5
8	B-4
7	A-4
6	B-3
5	A-3
4	B-2
3	A-2
2	B-1
1	A-1

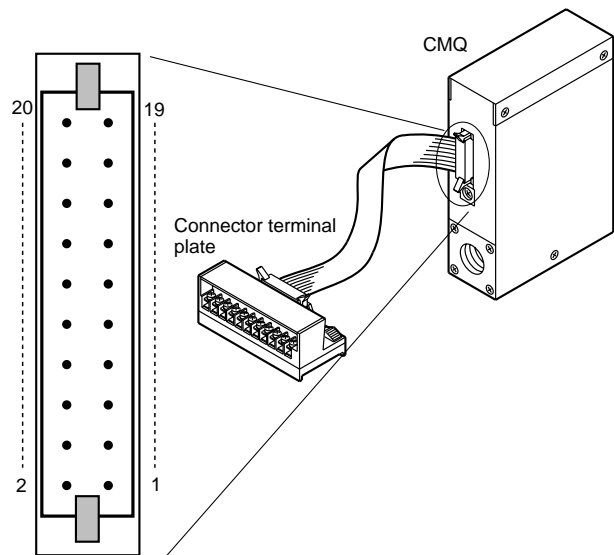

Chapter 4. BASIC OPERATION

4 - 1 Switching Displays

Each press of the **DISP** key switches the details indicated on the display.

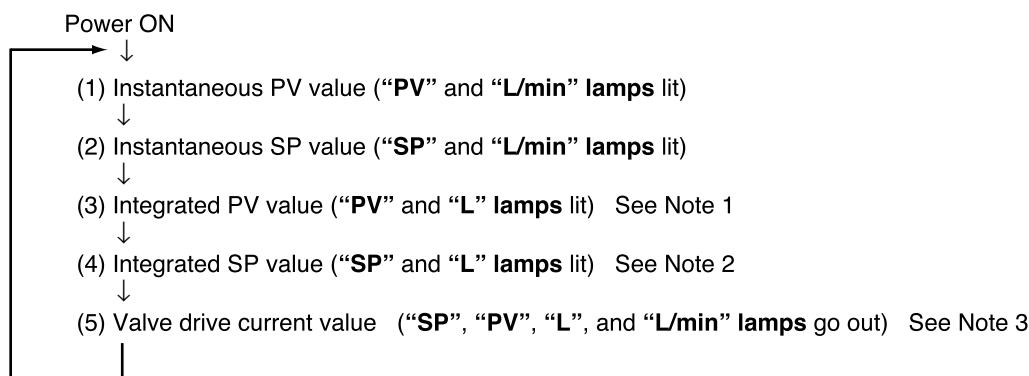

Note 1: The integrated PV value is reset to zero by holding down the **ENT** key for two seconds or more while the integrated PV value is displayed.

Note 2: The integrated SP value is displayed only when the event output assignment **[- 0 7** or “integration count up” **[- 0 8** are selected in the function setup, or when integration automatic shut-off selection **[- 1 3** is set to “ON” in the function setup. For details on how to set functions, see Chapter 5. APPLICATION OPERATION.

Note 3: This is displayed only when the valve drive current alarm ON (alarm used) is selected at valve drive current alarm setup type **[- 2 0** in the function setup. For details on how to set functions, see 5-1 Function Setup (page 5-1).

● Instantaneous PV display

When the power is turned ON, the “**PV**” and “**L/min**” lamps light, and the instantaneous PV is indicated on the display. When the operating mode is set to the fully closed mode, and the flowrate is zero, and when the operating mode is switched to the control mode or fully open mode, the operating mode (**0 F F / 0 0** / **F U L L**) is displayed for about one second. When an alarm occurs, the alarm code and the regular display are displayed alternately.

Note

- For details on operating modes, see 4-2 Selecting the Operating Mode (page 4-3).

● Instantaneous SP display

If the **DISP** key is pressed while the instantaneous PV is displayed, the “**PV**” lamp goes out, the “**SP**” lamp lights and the instantaneous SP value is indicated on the display. If the SP value is not changed while the instantaneous SP is displayed, the instantaneous PV is redisplayed automatically after about ten seconds.

When multi-SP (number of SPs 2 to 4) is selected at number of instantaneous SPs selection **[- 0 4** in the function setup, the instantaneous SP value is displayed for about one second, and then the display switches to the SP No.

Note

- For details on how to change the instantaneous SP, see 4-3 Setting the Flowrate (page 4-4).

● Integrated PV display

When the **DISP key** is pressed while the instantaneous SP value is displayed, the “**SP**” and “**L/min**” lamps go out, the “**PV**” and “**L**” lamps light, and the integrated PV value is indicated on the display.

- 4-digit or greater display

When the integrated PV value is 10,000 or higher, the value is displayed divided into two parts, the lower four digits, followed by the upper four digits. When the value is a four digit or smaller value, the decimal point on the display lights.

For example, when the integrated PV value is "123,456L", "3456." is displayed. Press the **DISP key** to display "12". To alternately display the upper and lower four digits, press the **◀ key**. When the integrated PV value reaches the integrated SP value, the “**PV**” lamp blinks. (It also blinks while the instantaneous PV is displayed.)

- Resetting integrated PV

The integrated PV value is reset to zero by holding down the **ENT key** for two seconds or more while the integrated PV value is displayed.

● Integrated SP display

If you press the **DISP key** while the integrated PV is displayed (while the upper four digits of the integrated PV value are displayed and when the integrated PV value is 10,000 or higher), the “**PV**” lamp goes out, the “**SP**” lamp lights and the integrated SP value is indicated on the 7-segment display.

Note, however, that the integrated SP value is displayed only when the event output assignment $\square - \square 7$ or “integration count up” $\square - \square 8$ are selected in the function setup, or when integration automatic shut-off selection $\square - 1 3$ is set to “ON” in the function setup. The integrated SP value is displayed divided into two parts, the lower four digits followed by the upper four digits, in the same way as the integrated PV value when the value is 10,000 or higher.

If the SP value is not changed while the instantaneous SP is displayed, the instantaneous PV is redisplayed automatically after ten seconds.



Note

For details on how to change the integrated SP, see ● Procedure for changing the integrated SP (only models with display) (page 4-7).

● Valve drive current display

If you press the **DISP key** while the integrated SP is displayed (on the model which does not support integrated SP display, when and the integrated PV is displayed), all of the “**PV**”, “**SP**”, “**L**” and “**L/min**” lamps go out, and the valve drive current value ($\square.\square$ to $100.\square$ [%]) is indicated on the 7-segment display.

Note, however, that the valve drive current value is displayed only when the valve drive current alarm setting $\square - 2 \square$ in the function setup is set to “alarm used” (1 to 3).

For details on how to set this function, see 5-1 Function Setup (page 5-1).

Set the valve drive current upper/lower alarm in the parameter setup mode. For details on how to set parameters, see 5-2 Parameter Setup (page 5-5).



Note

The valve drive current alarm can be used for monitoring valve drive current without the alarm being output. Select “alarm used” (1, 2 or 3) at valve drive current, alarm setup type $\square - 2 \square$, and leave the alarm current value setting at its factory setting. In the factory setting, the alarm is not output, and the alarm can be used for monitoring valve drive current.

4 - 2 Selecting the Operating Mode

Even when the power is turned ON for the first time, the valve remains fully closed, and the display indicates “**0 F F**” after instantaneous PV zero is displayed. (“**0 F F**” indicates that the operating mode is in the valve fully closed mode.)

Pressing the **RUN key** in this state starts control. “**0 0**” is displayed on the 7-segment display for about one second, followed by the instantaneous PV value. (“**0 0**” indicates that the operating mode is the valve control mode.)

Also, the “**OK**” lamp lights when the instantaneous PV is within the “instantaneous SP ± allowable range”.

If the **RUN key** is pressed again, the valve fully closed mode is returned to, and “**0 F F**” is displayed after instantaneous PV zero is confirmed. From here on, each press of the **RUN key** alternately switches between the valve control mode and the valve fully closed mode.

Note, however, that if the **RUN key** is held down for two or more seconds, the valve fully open mode is entered. Then, “**F U L L**” is indicated for one second on the display, followed by the instantaneous PV.

In the fully open mode, the “**OK**” lamp blinks.

● Table of operation mode displays

		Display	“OK” Lamp	Remarks
Operating mode	Fully closed mode	0 F F	Out	0 F F is displayed at all times after flowrate zero is confirmed.
	Control mode	0 0	Out or lit	0 0 is displayed for about 1 second when the control mode is entered.
	Fully open mode	F U L L	Blinking	F U L L is displayed for about 1 second when the fully open mode is entered.

Note 1: The operating mode is displayed only while the instantaneous PV is displayed.

Note 2: Once the power supply has been shut off, operation is resumed from the previous operation mode when the power supply is next turned ON.

Note 3: When “**RUN key disabled**” is selected by **RUN key** operation selection **[- 0 2]** in the function setup, use of the **RUN key** is disabled even if it is pressed.

When “operation mode switching” is selected at external 3-stage switching input assignment **[- 0 9]** in the function setup, forced fully closed/forced fully open input operations according to external switching input take precedence over **RUN key** operations.

In the same way, forced fully closed/forced fully open input operations according to external switching input take precedence over **RUN key** operations when “valve forced fully closed” or “valve forced fully open” is selected at external contact input assignments **[- 1 0]** to **[- 1 2]** in the function setup.

Note

For details on how to set up functions, see Chapter 5. APPLICATION OPERATION.

4 - 3 Setting the Flowrate

■ Procedure for changing digital instantaneous SP

● Single SP mode (number of SPs=1 according to function setup [- 0 4])

Follow the procedure below to change the SP value:

- (1) Press the **DISP key** to display the instantaneous SP.
- (2) Change the SP value by pressing the **▲** or **▼ keys**. You can move to the digit to be changed by pressing the **◀ key**. The digit currently being changed blinks while the SP value is being changed. At this point, the SP value is not updated.
- (3) When you have reached the target value, press the **ENT key** to fix the SP value. At this point, the SP value is updated.



Note (direct setup function)

Control can be executed using an SP value currently being changed (indicated by blinking display) when the direct setup function is enabled at instantaneous flowrate direct setup function switching [- 2 1] in the function setup. (The **ENT key** need not be pressed to fix the SP value. However, to switch the display by pressing the **DISP key**, press the **ENT key** to fix the SP value, and switch the display.)

This function is useful when changing the SP value a little at a time. (For details on how to set up functions, see Chapter 5. APPLICATION OPERATION.)

● Multiple-SP mode (number of SPs=2 to 4 according to function setup [- 0 4])

Up to four SP values can be switched by key operation on the display and by external contact input. Also, up to three SP values can be switched by external 3-stage switching input.

Follow the procedure below to change the SP No. and SP value:

- (1) Press the **DISP key** to display the instantaneous SP. (The display switches to SP No. $SP - 0$ to $SP - 3$ after about one second.)
- (2)-1 Press the **▲** or **▼ keys** to change the SP No., and press the **ENT key**.
- (2)-2 The SP value of the selected SP No. is displayed. If this SP value need not be changed, proceed to step (3).
Change the SP value by pressing the **▲** or **▼ keys**. You can move to the digit to be changed by pressing the **◀ key**. The digit currently being changed blinks while the SP value is being changed. At this point, the SP value is not updated.
- (3) When you have reached the target value, press the **ENT key** to fix the SP value. At this point, the SP value and SP No. are updated, and the SP value of the selected SP No. is switched to. (The display switches to the SP after about one second.)



Note (direct setup function)

Control can be executed using an SP No. or SP value currently being changed (indicated by blinking display) when the direct setup function is enabled at instantaneous flowrate direct setup function switching [- 2 1] in the function setup. (The **ENT key** need not be pressed to fix the SP value. However, to switch the display by pressing the **DISP key**, press the **ENT key** to fix the SP value, and switch the display.)

This function is useful when frequently changing the SP No. or when changing the SP value a little at a time. (For details on how to set up functions, see Chapter 5. APPLICATION OPERATION.)

Handling Precautions

- If you do not press any key after performing the operation in step (1), the instantaneous PV is automatically returned to after about 10 seconds.
- If you press the **DISP key** without pressing the **ENT key** after performing the operation in step (2), the SP value and SP No. are not updated, and the previous value remains.
- When the SP value is updated after performing the operation in step (3), the instantaneous PV value is automatically returned to after about two seconds.
- When "analog setting" is selected in instantaneous flowrate setup mode selection $\left[- \square \right]$ in the function setup, and operation is carried out using the SP value according to the analog setup voltage, changing of the SP value and SP No. using the **▲** or **▼ keys** is not accepted.
- Up to three SP values can be switched when "SP No. switching" is selected at external 3-stage switching input function assignment $\left[- \square \right]$ **9** in the function setup. Note, however, that the SP No. cannot be updated using the **▲** or **▼ keys**. (The SP value can be updated.)

Note

- For details on wiring and operation, see ● Wiring (page 3-7).
 - For details on how to set up functions, see Chapter 5. APPLICATION OPERATION.
- Up to four SP values can be switched as shown in the following table, according to the ON/OFF state of the external contact inputs, by assigning two of inputs 1 to 3 at external contact input function assignments $\left[- \square \right]$ to $\left[- \square \right]$ in the function setup to "SP No. switching." (1) to (3) in the table below show the possible combinations. For example, if the two inputs; input 1 (DI1) and input 2 (DI2) are used as shown in (1) in the table below, the SP can be selected according to the states of each of these inputs. Note, however, that the SP No. cannot be updated using the **▲** or **▼ keys**. (Only the SP value can be updated.)

Contact Input Assignment Combinations			SP to be Selected
(1)	Input (DI1)	Input (DI2)	
(2)	Input (DI1)	Input (DI3)	
(3)	Input (DI2)	Input (DI3)	
Contact input state	OFF	OFF	SP - 0
	ON	OFF	SP - 1
	OFF	ON	SP - 2
	ON	ON	SP - 3

Note

- For details on wiring and operations, see ● Wiring (page 3-7).
- For details on how to set up functions, see Chapter 5. APPLICATION OPERATION.

■ Procedure for changing analog instantaneous SP (models without display)

The instantaneous SP value can be changed by analog voltage by selecting the analog setting at instantaneous flowrate setting method selection $\boxed{[- 0]}$ in the function setup.

The analog voltage range for setup can be selected at instantaneous flowrate analog input voltage range selection $\boxed{[- 0]}$ in the function setup. The analog setting voltage value for the setting flowrate (instantaneous SP) can be calculated from the calculation formulas in the following table:

Voltage Range for Setting	How to Calculate Voltage for Setting
Internal reference 0 to 5V	Set voltage (V) = Set flowrate ÷ full-scale flowrate X Reference output voltage
External reference 0 to 5V	Set voltage (V) = Set flowrate ÷ full-scale flowrate X 5.00
External reference 1 to 5V	Set voltage (V) = Set flowrate ÷ full-scale flowrate X 4.00 + 1.00



Note

For details on how to set up functions, see Chapter 5. APPLICATION OPERATION.

! Handling Precautions

- When internal reference 0 to 5V is selected, the 5V reference voltage output from this device is used. The 5V reference voltage can be set easily without using a special setup device by using a potentiometer to divide this reference voltage before input.

Note, however, that the resultant 5V is not accurate, so to actually measure and calculate the reference voltage output from this device, use a voltage tester for the setup voltage calculation.

- The instantaneous SP value according to the analog setting can be verified without using the above calculation formula by pressing the **DISP key** to display the instantaneous SP. If the setting according to the analog voltage cannot be changed while the instantaneous SP is displayed, the instantaneous PV is redisplayed automatically after about 10 seconds.

● Procedure for changing the integrated SP

The integrated SP is used to generate an event (e.g. external output or automatic valve shut-off) when the integrated PV value reaches the SP value.

Pressing the **DISP key** will not display the integrated SP value except when “integration count up” is selected at event output assignments $\left[- \square \right]$ or $\left[- \square \right]$ **B** in the function setup, or when “automatic shut-off function ON” is selected at automatic integration shut-off function setting $\left[- ! \right]$ **B** in the function setup.



Note

For details on how to set up functions, see Chapter 5. APPLICATION OPERATION.

Follow the procedure below to change the SP value:

- (1) Press the **DISP key** to display the integrated SP. (The “**SP**” and “**L**” lamps light.)
- (2) Press the **▲** or **▼ keys** to change the SP value.
 You can move to the digit to be changed by pressing the **◀ key**. If you move by pressing the **◀ key** while the lower four digits of the SP value are displayed, the display changes to the upper four digits and the upper four digits can be changed.
 Likewise, if you move by pressing the **◀ key** while the upper four digits are displayed, the display changes to the lower four digits and the lower four digits can be changed.
 While the SP value is being changed, the digit being changed blinks. At this point, the SP value is not updated.
- (3) When you have reached the target value, press the **ENT key** to fix the SP value. At this point, the SP value is updated.

! Handling Precautions

- If you do not press any key after performing the operation in step (1), the integrated PV is automatically returned to after about 10 seconds.
- If you press the **DISP key** without pressing the **ENT key** after performing the operation in step (2), the SP value is not updated, and the previous value remains.
- When the SP value is updated after performing the operation in step (3), the integrated PV value is automatically returned to after about two seconds.

Chapter 5. APPLICATION OPERATION

5 - 1 Function Setup

● Setup method

Follow the procedure below to set functions such as event output type and external contact input assignments.

- (1) Press the **DISP key** to display the instantaneous PV. (The “**PV**” and “**L/min**” lamps light.)
- (2) If you simultaneously hold down the **▼** and the **ENT keys** for three seconds, item No. **[- 0]** is displayed on the 7-segment display and the function setup mode is entered.
- (3) Press the **▲** or **▼ key** to select the desired setup item No., and press the **ENT key**.
- (4) The current setting blinks on the 7-segment display. Press the **▲** or **▼ key** to select the desired setting.
- (5) When you have selected the desired setting, press the **ENT key** to fix the setting. At this point, the setting is updated. (After about one second, the item No. is redisplayed.)
- (6) If you want to set up other items, return to step (3) and repeat the procedure. Otherwise, proceed to step (7).
- (7) Press the **DISP key** to move from the function setup mode to the instantaneous PV display.

! Handling Precautions

- If you do nothing for one minute after entering the function setup mode, the display automatically returns to the regular (instantaneous PV) display.
- If you press the **DISP key** without pressing the **ENT key** after carrying out the operation in step (4), the setting remains at the previous value without being updated.

● Function setup item table

Display Item	Item Description	Setup Item and Description	Factory Setting	Remarks
[- 0 1	Key lock Run	0: Key lock disabled 1: Settings other than instantaneous SP and integrated SP are key-locked 2: All settings key-locked	0	The key lock can be disabled even while it is enabled. When an attempt is made to change a key-locked setting, LOC is indicated on the display.
[- 0 2	RUN key operation selection	0: RUN key disabled 1: RUN key enabled	1	
[- 0 3 Note 1	Instantaneous flow-rate setup method (instantaneous SP setup method selection)	0: Digital setup (set by key operation or communications) 1: Analog setup (set by external analog input voltage)	0	
[- 0 4	Number of instantaneous flowrate setups selection (number of instantaneous SPs selection)	0: Number of SPs = 1 (SP - 0 only) 1: Number of SPs = 2 (SP - 0, SP - 1) 2: Number of SPs = 3 (SP - 0 to SP - 2) 3: Number of SPs = 4 (SP - 0 to SP - 3)	0	
[- 0 5 Note 1	Instantaneous flowrate analog input voltage range selection (instantaneous SP)	0: Internal reference 0 to 5V input 1: External reference 0 to 5V input 2: External reference 1 to 5V input	0	Instantaneous flowrate analog input voltage range selection.(instantaneous SP analog input voltage range input by the potentiometer selection) Setting " 0" is for using the 5V reference voltage from the CMQ body when voltage is input by the potentiometer (variable resistor with dial, sold separately). (The external power supply for the setup is not required.) For details on wiring, see page 3-7.
[- 0 6 Note 1	Instantaneous flowrate analog output voltage range selection (instantaneous PV)	0: 0 to 5V output 1: 1 to 5V output	0	
[- 0 7	Event output 1 type assignment	0: Not used (OFF at all times) 1: Integration flowrate count up ON	0	The event output delay time is set in the parameter setup mode (see page 5-5). Note, however, that delay cannot be set to integration pulse output. For details on wiring, see page 3-7. 9: Events are outputted even in fully closed operation mode. 10:Events are not outputted in fully closed operation mode.
[- 0 8	Event output 2 type assignment	2: Integration pulse output 3: Instantaneous PV OK ON 4: ON in control mode 5: ON in fully open mode 6: ON in control or fully open mode 7: ON in fully closed mode 8: Instantaneous PV upper limit event 9: Instantaneous PV lower limit event 1 10:Instantaneous PV lower limit event 2	0	

Display Item	Item Description	Setup Item and Description	Factory Setting	Remarks
┌ - 09	External 3-stage switching function	0: Not used 1: Switching of operating 1 2: Switching of instantaneous SP No. 3: Switching of integration operation 4: Switching of analog I/O voltage range (simultaneous external switching of C-05 and C-06) 5: Switching of operating 2	1	External inputs OPEN/GND/5V are switched as follows: For details on wiring, see page 3-7. 1: Control/fully closed/fully open 2: SP-0/SP-1/SP-2 3: Continue count/reset count/stop count 4: (Input) Internal reference 0 to 5V / External reference 0 to 5V / External reference 1 to 5V (Output) 0 to 5V/0 to 5V/1 to 5V 5: fully closed/control/fully open
┌ - 10	External contact 1 input function assignment (2-stage switching)	0: Not used 1: Reset integration 2: Stop integration count operation 3: Switching of instantaneous SP No.	0	3: To select an SP No. of 3 or more setting, assign 4: The ┌ - 03 (analog/digital) setting is reflected when the contact is ON.
┌ - 11	External contact 2 input function assignment (2-stage switching)	4: Switching of instantaneous flowrate setup method 5: Valve forced fully closed 6: Valve forced fully open	0	7: "Slow start ON" must be selected in ┌ - 17. (Slow start when the contact is ON) Similarly, in case of SP ramp control, "SP ramp control 1 or 2" must be selected in ┌ - 27. (Ramp control when the contact is ON.)
┌ - 12	External contact 3 input function assignment (2-stage switching)	7: Switching of slow start operation or switching of instantaneous SP ramp control operation 8: Switching of operating mode (Control by contact ON, forced fully closed by contact OFF) 9: Flowrate zero conversion 10: Switching of gas type setup 11: Switching of flowrate range	0	9: Set the operation mode to full close or set the flowrate to zero and perform the contact ON operation for a minimum of 10 seconds. See page 6-2 for the details. 10: ┌ - 18 becomes active by contact OFF and ┌ - 26 becomes active by contact ON. 11: ┌ - 24 becomes active by contact OFF and ┌ - 25 becomes active by contact ON. 12: Parameter setup ramp 1 is selected when the contact is OFF. The ramp 2 is selected when the contact is ON.
┌ - 13	Switching of automatic integration shut-off function	0: Function disabled 1: Function enabled	0	When the integrated PV reaches the integrated SP, the value is fully closed.
┌ - 14	Switching of integrated reset function at start of control	0: Function disabled 1: Function enabled	0	When control is resumed from the fully closed operating mode, the integrated PV is automatically reset.
┌ - 15	Flowrate alarm setup type	0: Function disabled 1: Only upper limit alarm used 2: Only lower limit alarm used 3: Upper / lower limit alarm used	3	Set the alarm flowrate in the parameter setup mode. See page 5-5.

Display Item	Item Description	Setup Item and Description	Factory Setting	Remarks
[- 16	Operation selection at alarm occurrence	0: Control continued (alarm ignored) 1: Forced fully closed 2: Forced fully open	1	Alarm output turns ON even if "0" is selected.
[- 17	Slow start setup	0: Slow start OFF 1 to 8: Slow start ON (equivalent to approx. 1 to 6 seconds settling time)	0	Slow start is adopted when the external contact input turns ON when slow start operation switching is selected at [- 10 to [- 12.
[- 18	Gas type selection 1	0: Conversion factor for each gas type set by the user 1: Air, nitrogen 2: Oxygen 3: Argon 4: Carbon dioxide (CO ₂) 5: City gas 13A (LNG) 6: Propane 100% 7: Methane 100% 8: Butane 100%	-	The gas type of the model number is set as a factory setting. "2" cannot be selected for the models other than the oxygen model. The factory setting conforms to the gas type selected for the model No. If the flowrate range changes due to a change in the gas type, the flowrate OK range and flowrate alarm range in the parameter setup must be changed. When "0" is selected, set the conversion factor (CF) in the parameter setup mode. If "10" is selected for any of the [- 10 to [- 12 (external contact input function assignment) and only when an objective contact is turned ON, the gas type is the one selected by [- 26 (Gas type selection 2)
[- 19	Flowrate display	0: 20°C, referenced to 1 atmosphere 1: 0°C, referenced to 1 atmosphere 2: 25°C, referenced to 1 atmosphere	0	
[- 20	Valve drive current alarm setup type	0: Valve drive current alarm not used 1: Only upper alarm used 2: Only lower limit alarm used 3: Upper / lower limit alarm used	0	Set up the alarm current value in the parameter setup See page 5-5.
[- 21	Instantaneous flowrate direct setup function switching	0: Function disabled 1: Function enabled	0	Can be controlled by instantaneous SP being change (flashing).
[- 22	Control dead zone setting	0: Function disabled 1: Function enabled	0	Valve operation stops while the instantaneous PV is within the OK judgment range. The OK judgment range can be set in the parameter setting mode.
[- 22	Control dead zone setting	0: Function disabled 1: Function enabled	0	Valve operation stops while the instantaneous PV is within the OK judgment range. The OK judgment range can be set in the parameter setting mode.

Display Item	Item Description	Setup Item and Description	Factory Setting	Remarks
┌ - 23	Instantaneous PV filter (process for filtering)	0: Without filter 1: Sampling 2 times moving-average 2: Sampling 4 times moving-average 3: Sampling 8 times moving-average	0	If the PV filter is used in a " 2" or " 3" setting, the operation differential pressure must be lower than the standard differential pressure. Do not change the setting while controlling.
┌ - 24	Flowrate range setup 1	0: Standard range 1 to 9:1/2 to 1/10 of Standard range	0	Setting and indication resolution can be improved adjusting by the control flowrate range to be 1/2 to 1/10 of the standard range (flowrate range at factory setting). See page 7-7 for details.
┌ - 25	Flowrate range setup 2	Standard range	0	This setting becomes active if " 11" is selected for assignments ┌ - 10 to ┌ - 12 (external contact input function assignment) and only when the objective contact is turned ON. However, the range selected by ┌ - 24 becomes active other than the above. See the remarks column for ┌ - 10 to ┌ - 12 for details.
┌ - 26	Gas type selection 2	0: Conversion factor for each gas type set by the user 1: Air, nitrogen 2: Oxygen 3: Argon 4: Carbon dioxide (CO ₂) 5: City gas 13A (LNG) 6: Propane 100% 7: Methane 100% 8: Butane 100%	-	The gas type of the model number is factory set. This setting becomes active if " 10" is selected for assignments ┌ - 10 to ┌ - 12 (external contact input function assignment) and only when an objective contact is turned ON. See the remarks column for ┌ - 10 to ┌ - 12 and ┌ - 18 for details.
┌ - 27	Instantaneous SP ramp control function	0: Function disabled 1: SP ramp control 1 (In SP ramp-up: Ramp 1 In SP ramp-down: Ramp 2) 2: SP ramp control 2 (In external contact OFF: Ramp 1 In external contact ON: Ramp 2)	0	The SP change ramp level (the rate of change per second) can be set to the constant value for the control start and flowrate set point change. The ramp 1 and 2 settings are performed in parameter setup mode. See  page 5-7 for details. In case of SP ramp control 2, the operation is performed by the ramp 2 when " 12" is selected in either one of ┌ - 10 to ┌ - 12 (external contact input function assignment) and also when the target contact is ON, the operation other than the above conditions is performed by the ramp 1. If " 7" is selected in either one of ┌ - 10 to ┌ - 12, SP ramp control is performed only when the target contact is ON.

Display Item	Item Description	Setup Item and Description	Factory Setting	Remarks
[- 2 8	Analog optional scaling function	0: Function disabled 1: Function enabled	0	The flowrate at analog input / output 100% (5V) can be optionally set. The flowrate is set in parameter setup mode. See  page 5-7 for details.
[- 3 0 Note 2	Communications address setting	0: Communications function disabled 1 to 127: Communications address	0	
[- 3 1 Note 2	Transfer speed selection	0: 9600bps 1: 4800bps 2: 2400bps 3: 1200bps	0	
[- 3 2 Note 2	Communications conditions selection	0: 8 data bits, even parity, 1 stop bit 1: 8 data bits, no parity, 2 stop bits	0	

Note 1: When external switching by external 3-stage switching input [- 0 9 or external contact inputs [- 1 0 to [- 1 2 is selected, switching according to external input takes precedence.

Note 2: These items can be set only on models with display and communications function option.

5 - 2 Parameter Setup

● Setup method

Follow the procedure below to set constants such as flowrate deviation alarm upper and lower limit setting values and event output delay times :

- (1) Press the **DISP key** to display the instantaneous PV. (The “PV” and “L/min” lamps light.)
- (2) If you hold down the **◀ key** for three seconds, item No. **0. r 7 9** is displayed on the 7-segment display and the parameter setup mode is entered.
- (3) Press the **▲** or **▼ key** to select the desired setup item No., and press the **ENT key**.
- (4) The current setting blinks on the 7-segment display. Press the **▲** or **▼ key** to change the setting to the desired setting. You can move to the digit to be changed by pressing the **◀ key**.
- (5) When you have finished changing the setting, press the **ENT key** to fix the setting. At this point, the setting is updated. (After about one second, the item No. is redisplayed.)
- (6) If you want to set up other items, return to step (3) and repeat the procedure. Otherwise, proceed to step (7).
- (7) Press the **DISP key** to redisplay the instantaneous PV mode from the parameter setup mode.

! Handling Precautions

- If you do nothing for one minute after entering the parameter setup mode, the display automatically returns to the regular (instantaneous PV) display.
- If you press the **DISP key** without pressing the **ENT key** after carrying out the operation in step (4), the setting remains at the previous value without being updated.

● Parameter setup item list

No.	Display	Description	Factory Setting	Setting Range	Remarks
1	Q . r n 9 Note 1	Instantaneous flowrate OK judgment range	(2%FS) L/min(standard)	(0.5 to 100%FS) L/min(standard)	The result becomes the flowrate (L/min(standard))obtained by multiplying the full-scale flowrate by the percentage in parentheses. (The factory setting and setting vary according to the gas type)
2	Q . H Y 5 Note 1	Instantaneous flowrate OK judgment hysteresis	(1%FS) L/min(standard)	(0.5 to 100%FS) L/min(standard)	
3	A . H I Note 2	Instantaneous flowrate deviation upper limit alarm	(10%FS) L/min(standard)	(0.5 to 100%FS)	
4	A . H . H Y Note 2	Instantaneous flowrate deviation upper limit alarm hysteresis	(2%FS) L/min(standard)	(0.5 to 100%FS) L/min(standard)	
5	A . L 0 Note 2	Instantaneous flowrate deviation lower limit alarm	(10%FS) L/min(standard)	(0.5 to 100%FS) L/min(standard)	
6	A . L . H Y Note 2	Instantaneous flowrate deviation lower limit alarm hysteresis	(2%FS) L/min(standard)	(0.5 to 100%FS) L/min(standard)	
7	A . d L Y	Instantaneous flowrate deviation alarm judgment delay time	10s	0.5 to 999.9s	
8	E . 1 . d L	Event 1 output delay time	0.0s	0.0 to 999.9s	Even if the delay time is set, it is disabled during selection of integration pulse output.
9	E . 2 . d L	Event 2 output delay time	0.0s	0.0 to 999.9s	
10	C . F . Note 3	User setup conversion factor	1.000	0.100 to 9.999	
11	A . I . H I Note 4	Valve drive current upper limit alarm	100.0%	0.1 to 100.0%	At the factory setting, alarms are not detected. See Handling Precautions on page 5-7.
12	A . I . L 0 Note 4	Valve drive current lower limit alarm	0.0%	0.0 to 99.9%	
13	E . 1 . 5 P Note 5	Event 1 output upper/lower limit flowrate setup	(0%FS) L/min(standard)	(0 to 100%FS) L/min(standard)	The result becomes the flowrate (L/min(standard))obtained by multiplying the full-scale flowrate by the percentage in parentheses. (The factory setting and setting vary according to the gas type)
14	E . 2 . 5 P Note 5	Event 2 output upper/lower limit flowrate setup	(0%FS) L/min(standard)	(0 to 100%FS) L/min(standard)	
15	r A P . 1 Note 6	Instantaneous SP ramp control Ramp 1	CMQ9200/9500 : 0.0 CMQ0002/0005 : 0.000	CMQ9200/9500 : 0.0 to 999.9 CMQ0002/0005 : 0.000 to 9.999	The flowrate to change per second is set. Flowrate unit:L/min(standard) (However, the unit is mL/min (standard)for the CMQ9200 / 9500.) Ramp control does not function if the value remains at initial value (ramp zero). (Immediately the value becomes the SP to come after change.)
16	r A P . 2 Note 6	Instantaneous SP ramp control Ramp 2	CMQ0020/0050 : 0.00	CMQ0020/0050 : 0.00 to 99.99	
17	A . 5 C L Note 7	Analog optional scaling	(100%FS) Note 8	CMQ9200/9500 : 10.0 to (100%FS) CMQ0002/0005 : 0.100 to (100%FS) CMQ0020/0050 : 1.00 to (100%FS) Note 9	The flowrate of analog input / output 100%(5V) is set. (The 2 digits of lower position cannot be reflected even if it is set. Unit: L/min(standard) (However, the unit is mL/min (standard) for the CMQ9200 / 9500.)

Note 1: Operation during judgment of instantaneous flowrate OK.

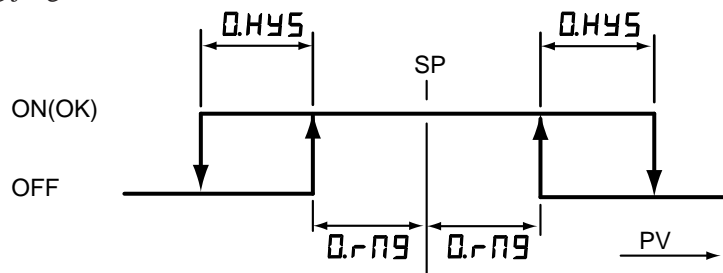

Note 2: Operation during judgment of instantaneous flowrate deviation upper and lower limit alarms.

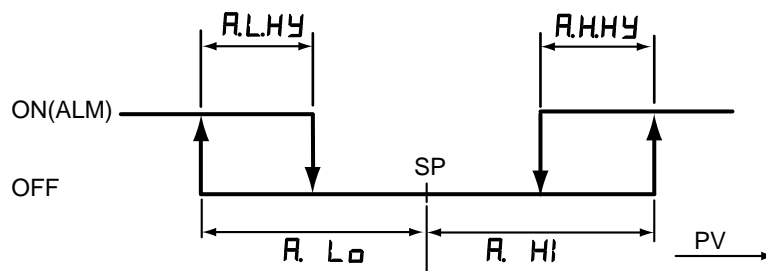

Note 3: This can be set only when "User setting" is selected at gas type selection $\text{C} - 1 \text{B}$ in the function setup. If "0: User setting" is selected for both $\text{C} - 1 \text{B}$ and $\text{C} - 2 \text{B}$, the conversion factor will remain the same.

Note 4: These alarms can be set only when valve drive current "alarm used" (1 to 3) is set at valve drive current alarm setup type $\text{C} - 2 \text{D}$ in the function setup.

Note 5: This can be set only when "8 to 10: Instantaneous PV upper / lower limit event 1, 2" has been selected for the $\text{C} - 0 \text{7}$ and $\text{C} - 0 \text{8}$ event output type assignment in the function setup.

Note 6: This can be set only when "1 and 2: SP ramp control" has been selected for the $\text{C} - 2 \text{7}$ instantaneous SP ramp control function in the function setup.

Note 7: This can be set only when "1: Function enabled" has been selected for the $\text{C} - 2 \text{8}$ analog optional scaling function in the function setup.

Note 8: The result of the factory setting and setting range becomes the flowrate obtained by multiplying the full scale flowrate by the percentage in parentheses. (The factory setting and setting range vary according to the gas type.)

Note 9: The result of upper limit value of setting range becomes the flowrate obtained by multiplying the full scale flowrate by the percentage in the parenthesis. (The upper limit value varies according to the gas type.)

! Handling Precautions

The valve drive current changes greatly according to the differential pressure even if the flowrate is the same. For this reason, the valve drive current alarm function cannot be used under unstable differential pressure conditions.

Even under stable differential pressure conditions, hysteresis characteristics (drive current differs even if the flowrate is the same) are applied to the relationship between the valve drive current and the flowrate. So, to use the valve drive current alarm function, first sufficiently test in the operating conditions to check the valve drive current range, and then determine the alarm current setting value.

Chapter 6. MAINTENANCE AND TROUBLESHOOTING

■ Alarm code display

When a flowrate alarm occurs or when an alarm occurs during controller self-diagnostics, alarm output turns ON, and the operating mode currently selected to “Operation selection at alarm occurrence” $\bar{C} - 1\bar{B}$ in the function setup is forcibly switched to.

The “**ALM**” (alarm) lamp lights, and the 7-segment display alternately indicates the alarm codes shown in the table below and the regular display.

The alarm code is displayed only when the instantaneous PV or integrated PV is displayed.

! Handling Precautions

If a sensor error ($\bar{A} \bar{L} \bar{B} \bar{1}$) occurs, the flowrate measurement value will become indefinite.

Therefore, the control flowrate becomes indefinite even if "0:Control continued (alarm ignored)" was selected for $\bar{C} - 1\bar{B}$ in the function setup.

Alarm Code	Description	Cause	Remedy
$\bar{A} \bar{L} \bar{0} \bar{1}$	Instantaneous flowrate deviation lower limit alarm	Insufficient alarm judgment delay time, power voltage, inlet pressure, etc.	Otherwise, ask for repair.
$\bar{A} \bar{L} \bar{0} \bar{2}$	Instantaneous flowrate deviation upper limit alarm	Insufficient alarm judgment delay time, valve trouble, sensor trouble	Ask for repair if the delay time is not a problem.
$\bar{A} \bar{L} \bar{1} \bar{1}$	Valve drive current lower limit alarm	Insufficient alarm judgment delay time, alarm setting current value too high, excessive inlet pressure, etc.	Review setting value.
$\bar{A} \bar{L} \bar{1} \bar{2}$	Valve drive current upper limit alarm	Insufficient alarm judgment delay time, alarm setting current value too low, insufficient power voltage, insufficient inlet pressure, etc.	Review setting value.
$\bar{A} \bar{L} \bar{B} \bar{1}$	Sensor error	Sensor trouble, foreign object on sensor, excessive flowrate (sensor safety circuit activated), entering of hydrogen or helium gas	If sensor is not restored after turning power OFF then ON again, ask for repair.
$\bar{A} \bar{L} \bar{9} \bar{1}$	I/O correction data error	Data corrupted due to electrical noise.	Ask for repair
$\bar{A} \bar{L} \bar{9} \bar{2}$	Sensor calibration data error	Data corrupted due to electrical noise.	Ask for repair.
$\bar{A} \bar{L} \bar{9} \bar{3}$	User setup data error	Power shut-off during writing of data	Set data again.

■ Other trouble

Symptom	Cause	Remedy
Flowrate display does not become zero even in spite of an actual zero flowrate (Display does not become 0 F F even if the valve is fully closed.)	<ul style="list-style-type: none"> The body is installed vertically. Condensation on sensor Zero point of sensor deviated. 	<ul style="list-style-type: none"> Install horizontally. Insert a mist trap upstream. Compensate the flowrate zero
Flowrate does not stabilize.	<ul style="list-style-type: none"> Operation differential pressure range is exceeded. Large primary size pressure fluctuations Regulator interference Large pressure loss between regulator and CMQ (Primary pressure is fluctuating greatly according to flowrate.) 	<ul style="list-style-type: none"> Lower the primary pressure. Insert a regulator upstream. Change the regulator pressure setting or apply the instantaneous PV filter (Function setup [- 2 3]). Increase the pipe diameter.
Poor precision	<ul style="list-style-type: none"> Temperature reference does not match the reference flow meter. Regulator is vibrating slightly. Foreign object attached to sensor 	<ul style="list-style-type: none"> Match the temperature reference. (Can be changed in the function setup.) Change the regulator pressure setting. Ask for repair.

● Flowrate zero compensation

If a probable cause of the flowrate not becoming zero in spite of an actual zero flowrate is that the sensor's zero point has deviated, compensate the flowrate zero point as follows:

- Press the **DISP key** to display the instantaneous PV.
(The “PV” and “L/min” lamps light.)
- Set the operating mode to the fully closed mode, or set the setting flowrate to zero, and fully close the valve.
- Continue pressing the **ENT key** in this state.
- After about 10 seconds, **0 . C A L** is indicated on the display. After about one second, release the ENT key.
- The display changes to **0 F F**. (This completes flowrate zero compensation.)

Handling Precautions

Perform flowrate zero compensation with the actual flowrate stabilized to zero after completely replacing the inside of the flow channel with the actually used gas.

Note

Flowrate zero conversion operation can be performed by an external contact input by selecting “flowrate zero conversion” for **[- 1 0]** to **[- 1 2]** in the function setup. For details on how to set up functions, See Chapter 5. APPLICATION OPERATION.

Chapter 7. SPECIFICATIONS

■ Specifications

Specifications are given on the next page.

Chapter 7. SPECIFICATIONS

Item		Model No.	CMQ9200	CMQ9500	CMQ0002
Valve type		Proportional solenoid valve			
Valve operation		Normally closed when de-energized (N.C.)			
Standard full-scale flowrate (nitrogen conversionvalue) Note 1		200 mL/min(standard)	0.500 L/min(standard)	2.00 L/min(standard)	
Standard compatible gas types Note 2		Nitrogen, air, oxygen, argon, carbon dioxide (CO ₂), city gas 13A (LNG), methane 100%, propane 100%, Butane 100% Note, however, that gas must be a dry gas not containing corrosive components (chlorine, sulfur, acid). The gas must also be a clean gas not containing dust or oil mist.			
Control	Range	1 to 100%FS (See Table in Note 1.)			
	Response	Within 0.5s at setting $\pm 2\%$ FS (typ.)			
	Valve output update cycle	10ms			
	Accuracy (at standard temperature and differential temperature)	(1) Flowrate of 0 to 50% of full scale: Within $\pm 0.5\%$ FS (2) Flowrate of 51 to 100% of full scale: Within $\pm 1\%$ FS	Within $\pm 2\%$ FS	Within $\pm 1\%$ FS	
	Repeatability	(1) Flowrate of 0 to 50% of full scale: Within $\pm 0.25\%$ FS (2) Flowrate of 51 to 100% of full scale: Within $\pm 0.5\%$ FS	Within $\pm 1\%$ FS	Within $\pm 0.5\%$ FS	
	Temperature influence	(1) Flowrate of 0 to 75% of full scale	:0.10%FS max. per1°C	(2) Flowrate of 76 to100% of full scale :0.15%FS max. per1°C	
	Pressure influence	0.2%FS max. per 98kPa			
Pressure	Standard differential pressure Note 3	98kPa	9.8kPa	98kPa	
	Required differential pressure Note 4	49kPa	4.9kPa	49kPa	
	Operating differential pressure range Note 4	0.98 to 294kPa	0.49 to 49kPa	0.98 to 294kPa	
	Pressure resistance	980kPa			
Temperature	Standard operating temperature Note 3	+25°C			
	Allowable operating temperature range	-10 to +60°C			
	Allowable storage temperature range	-20 to +70°C			
Humidity	Allowable operating humidity range	10 to 90%RH (condensation not allowed)			
External leaks	Helium leak rate (only models 1/4VCR connection type)	Within 1×10^{-6} Pa·m ³ /s			
Flowrate setup	Setup method	(1) Key operation (2) External setup voltage input (3) Communications (only models supporting a communications function)			
	Setup resolution	See Table in Note 1.			
	Setup input voltage range	0 to 5Vdc/1 to 5Vdc (selectable by function setup and external input)			

CMQ0005	CMQ0020	CMQ0050
Proportional solenoid valve		
Normally closed when de-energized (N.C.)		
5.00 L/min(standard)	20.0 L/min(standard)	50.0 L/min(standard)
Nitrogen, air, oxygen, argon, carbon dioxide (CO ₂), city gas 13A (LNG), methane 100%, propane 100%, Butane 100% Note, however, that gas must be a dry gas not containing corrosive components (chlorine, sulfur, acid). The gas must also be a clean gas not containing dust or oil mist.		
1 to 100%FS (See Table in Note 1.)		
Within 0.5s at setting $\pm 2\%$ FS (typ.)		
10ms		
Within $\pm 2\%$ FS	Within $\pm 1\%$ FS	Within $\pm 1\%$ FS
Within $\pm 1\%$ FS	Within $\pm 0.5\%$ FS	Within $\pm 0.5\%$ FS
0.10%FS max. per 1°C		
0.2%FS max. per 98kPa		
9.8kPa	98kPa	196kPa
4.9kPa	49kPa	98kPa
0.49 to 49kPa	0.98kPa to 294kPa	0.98kPa to 294kPa
980kPa		
+25°C		
-10 to +60°C		
-20 to +70°C		
10 to 90%RH (condensation not allowed)		
Within $1 \times 10^{-6} \text{Pa} \cdot \text{m}^3/\text{s}$		
(1) Key operation (2) External setup voltage input (3) Communications (only models supporting a communications function)		
See Table in Note 1.		
0 to 5Vdc/1 to 5Vdc (selectable by function setup and external input)		

Chapter 7. SPECIFICATIONS

Item		Model No.	CMQ9200	CMQ9500	CMQ0002
Flowrate display	Display method	7-segment LED 4 digits			
	Setup resolution	See Table in Note 1.			
	Indication accuracy (at standard temperature and differential temperature)	±1%FS ±1 digit	±2%FS ±1 digit	±1%FS ±1 digit	
Integration function	Display/setup range	0.01 to 999,999.99L	0.01 to 999,999.99L	0.1 to 999,999.9L	
	Display/setup resolution	0.01L	0.01L	0.1L	
	Integration backup timing	(1) At each 2L count (2) At each hour (time) from the previous backup (3) When the RUN key is pressed	(1) At each 5L count	(1) At each 20L count	
Flowrate output	Output scale	0 to full-scale flowrate			
	Standard output voltage range	0 to 5Vdc/1 to 5Vdc (selectable by function setup and external input)			
	Max. output voltage	7Vdc max. (max. output when flowrate exceeds range)			
	Accuracy	±0.5%FS (The input impedance of the connected device must be at least 100kΩ.) Overall output accuracy: Indication accuracy ±0.5%FS			
Alarm/event output	Number of outputs	Alarm output: 1, Event output: 2			
	Output rating	30Vdc, 30mA (open collector non-insulated output)			
	Integration pulse output width	100ms ±10% (when pulse output is selected in the function setup)			
	Integration pulse output rate	0.01L/1 pulse	0.01L/1 pulse	0.1L/1 pulse	
External switching input	Input type, number of inputs	External 3-stage switching input (OPEN/GND/5V): 1 External contact input (2-stage switching): 3			
	Other party circuit type	Non-voltage contact, or open collector			
	Contact OFF terminal voltage	External 3-stage switching input: 2.5 ±0.5V External contact input: 2.8 ±0.5V			
	Contact ON terminal current	Approx. 0.5mA (current flowing to contact)			
	Allowable ON contact resistance	Max. 250Ω			
	Allowable OFF contact resistance	Min. 100kΩ			
	Allowable ON residual voltage	Max. 1.0V (open collector at other party)			
	Allowable OFF leakage current	Max. 50μA (open collector at other party)			
Reference voltage output	Output rating	5.0Vdc ±5% 5mA max.			
	Application	Reference voltage of flowrate setting voltage and 5V input of external 3-stage switching input			
Power	Rating	15 to 24Vdc, max. current consumption: 300mA			
	Allowable power voltage range	13.5 to 26.4V (ripple 5% max.)			
	Yamatake recommended power supply	Model No.: WN790A105 (up to 2 CMQs can be connected)			
Material of gas-contacting parts		SUS316, Teflon, Viton			
Connection method		9/16-18UNF, 1/4Rc, 1/4Swagelok, 1/4VCR			
Mounting orientation		Horizontal. Note that display surface must not face down.			
Mass		Approx. 1.2kg			
Applicable standard		EN61326 : 1997 / Amendment A1 : 1998			

CMQ0005	CMQ0020	CMQ0050
7-segment LED 4 digits		
See Table in Note 1.		
±2%FS ±1 digit	±1%FS ±1 digit	±1%FS ±1 digit
0.1 to 9,999,999.9L	1 to 99,999,999L	1 to 99,999,999L
0.1L	1L	1L
(1) At each 50L count	(1) At each 200L count	(1) At each 500L count
(2) At each hour (time) from the previous backup (3) When the RUN key is pressed		
0 to full-scale flowrate		
0 to 5Vdc/1 to 5Vdc (selectable by function setup and external input)		
7Vdc max. (max. output when flowrate exceeds range)		
±0.5%FS (The input impedance of the connected device must be at least 100kΩ.) Overall output accuracy: Indication accuracy ±0.5%FS		
Alarm output: 1, Event output: 2		
30Vdc, 30mA (open collector non-insulated output)		
100ms ±10% (when pulse output is selected in the function setup)		
0.1L/1 pulse	1L/1 pulse	1L/1 pulse
External 3-stage switching input (OPEN/GND/5V): 1 External contact input (2-stage switching): 3		
Non-voltage contact, or open collector		
External 3-stage switching input: 2.5 ±0.5V External contact input: 2.8 ±0.5V		
Approx. 0.5mA (current flowing to contact)		
Max. 250Ω		
Min. 100kΩ		
Max. 1.0V (open collector at other party)		
Max. 50μA (open collector at other party)		
5.0Vdc ±5% 5mA max.		
Reference voltage of flowrate setting voltage and 5V input of external 3-stage switching input		
15 to 24Vdc, max. current consumption: 300mA		
13.5 to 26.4V (ripple 5% max.)		
Model No.: WN790A105 (up to 2 CMQs can be connected)		
SUS316, Teflon, Viton		
9/16-18UNF, 1/4Rc, 1/4Swagelok, 1/4VCR		
Horizontal. Note that display surface must not face down.		
Approx. 1.2kg		
EN61326 : 1997 / Amendment A1 : 1998		

Note 1: L/min (standard) indicates the volumetric flow rate (L/min) per minute after conversion to 20°C , 1 atmosphere.

On models with display, the reference temperature can also be changed to 0°C or 25°C in display item $\square - 19$ flowrate display unit selection.

The controllable flowrate range varies according to the gas type. The table below shows the flowrate ranges for each of the gas types.

Specifications Gas type	CMQ9200		CMQ9500		CMQ0002	
	Control flowrate range mL/min(standard)	Setup/display resolution mL/min(standard)	Control flowrate range L/min(standard)	Setup/display resolution L/min(standard)	Control flowrate range L/min(standard)	Setup/display resolution L/min(standard)
Air, nitrogen	2 to 200	1	0.004 to 0.500	0.002	0.02 to 2.00	0.01
Argon	2 to 200	1	0.004 to 0.500	0.002	0.02 to 2.00	0.01
Carbon dioxide	1.0 to 120.0	0.5	0.003 to 0.300	0.001	0.010 to 1.200	0.005
Oxygen	2 to 200	1	0.004 to 0.500	0.002	0.02 to 2.00	0.01
City gas 13A (LNG)	2 to 200	1	0.004 to 0.500	0.002	0.02 to 1.60	0.01
Methane 100%	2 to 200	1	0.004 to 0.500	0.002	0.02 to 2.00	0.01
Propane 100%	0.6 to 60.0	0.2	0.002 to 0.160	0.001	0.006 to 0.600	0.002
Butane 100%	0.4 to 50.0	0.2	0.001 to 0.120	0.001	0.004 to 0.400	0.002

Specifications Gas type	CMQ0005		CMQ0020		CMQ0050	
	Control flowrate range L/min(standard)	Setup/display resolution L/min(standard)	Control flowrate range L/min(standard)	Setup/display resolution L/min(standard)	Control flowrate range L/min(standard)	Setup/display resolution L/min(standard)
Air, nitrogen	0.04 to 5.00	0.02	0.2 to 20.0	0.1	0.4 to 50.0	0.2
Argon	0.04 to 5.00	0.02	0.2 to 20.0	0.1	0.4 to 50.0	0.2
Carbon dioxide	0.03 to 3.00	0.01	0.10 to 12.00	0.05	0.3 to 30.0	0.1
Oxygen	0.04 to 5.00	0.02	0.2 to 20.0	0.1	0.4 to 50.0	0.2
City gas 13A (LNG)	0.04 to 5.00	0.02	0.2 to 20.0	0.1	0.4 to 50.0	0.2
Methane 100%	0.04 to 5.00	0.02	0.2 to 20.0	0.1	0.4 to 50.0	0.2
Propane 100%	0.02 to 1.60	0.01	0.06 to 6.00	0.02	0.2 to 16.0	0.1
Butane 100%	0.010 to 1.200	0.005	0.04 to 4.00	0.02	0.10 to 10.00	0.05

Note 2: For details on use in gases other than standard compatible gas types, mixed gases or gases containing hydrogen or helium, contact Yamatake.

Note 3: Target temperature and pressure during calibration.

Note 4: Differential pressure required for obtaining full-scale flowrate.

Note 5: Operation is possible even under required differential pressure. (Note, however, that the controllable flowrate range becomes narrower.)

● **Optional parts (sold separately)**

Item	Part No.	Remarks
Cable with special connector	81446681-001	20-core flat cable 2m (AWG#24)
AC adapter	81446682-001	Rating: 15Vdc, 350mA 15Vdc 350mA
Potentiometer for setting flowrate	81446683-001	Digital dial type, 5kΩ, 10 turns

■ Relationship between flowrate when valve is fully open and differential pressure

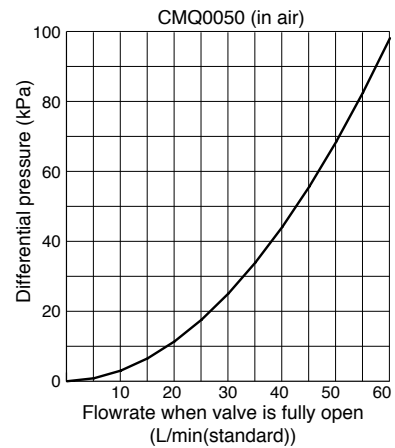
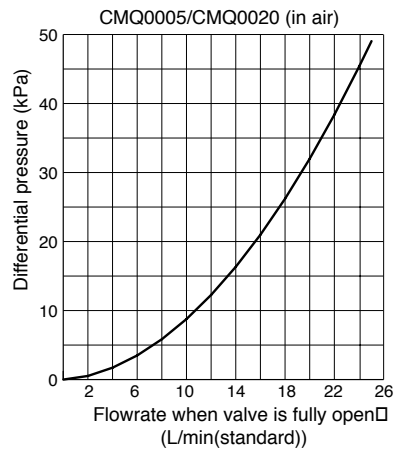
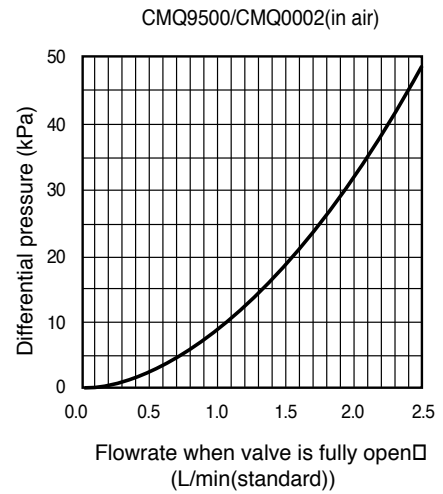
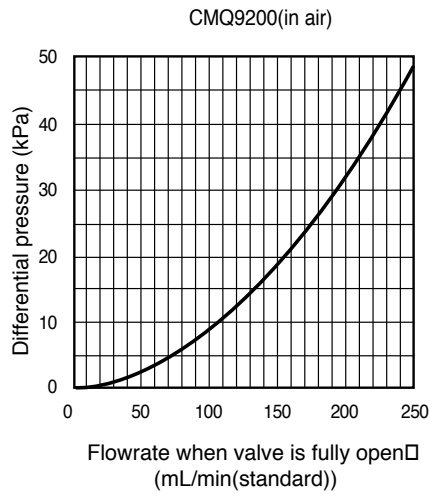

! Handling Precautions

Calculate the differential pressure from the following formula when a gas other than air is used:

Differential pressure
= differential pressure in air X specific gravity of gas to be controlled

Example) The differential pressure when 13A gas flows at 1.0L/min (standard) is (CMQ0002):

$$9\text{kPa} \times 0.64 = 5.76\text{kPa}$$

Specific Gravity of Standard Compatible Gas (air is taken as 1.0)	
Argon	1.38
Carbon dioxide	1.53
Oxygen	1.11
City gas 13A (LNG)	0.64
Methane 100%	0.56
Propane 100%	1.56
Butane 100%	2.08

■ Full scale flowrate and resolution at flowrate range change

The range can be reduced to a value 1/2 to 1/10 of the standard range for each model number by using flowrate range setup functions $\text{C} - 24$ and $\text{C} - 25$.

The full-scale flowrate and resolution at flowrate range change are given for each model number in the followed pages.

! Handling precautions

- The specifications for accuracy are the same as those for standard range even if the flowrate range has been changed. (%FS full-scale refers to the value of the standard range).

However, the repeatability is improved as described below.

(1)CMQ9500 to 0050

If the range is set to more than 1/5 of the standard range, the value of repeatability where a newly set flowrate range is full-scale is given.

Example :

If a range of 1/4 is set to the CMQ0020 when argon gas is used:

$$\pm 0.5\% \times 5.00\text{L/min} = \pm 0.025\text{L/min}$$

If the range is set to less than 1/5, the value of repeatability where 1/5 flowrate range is full-scale is given.

Example :

If a range of 1/10 is set to the CMQ0020 when argon gas is used:

$$\pm 0.5\% \times 4.00\text{L/min} = \pm 0.02\text{L/min}$$

(2)CMQ9200

If the range is set to 1/2 of the standard range, the value of repeatability where a 1/2 flowrate range is full-scale is given. If the range is set to less than 1/2, the value of repeatability where 1/2 flowrate range is full-scale is given.

- Even if the flowrate range is changed, the minimum control value remains the same as that of the standard range. Although a lower value than this may be set, control defaults to the minimum value in the standard range.

● CMQ9200

	Range setup=0		Range setup=1		Range setup=2		Range setup=3		Range setup=4	
	Full-scale (mL/min)	Resolution (mL/min)	Full-scale (mL/min)	Resolution (mL/min)	Full-scale (mL/min)	Resolution (mL/min)	Full-scale (mL/min)	Resolution (mL/min)	Full-scale (mL/min)	Resolution (mL/min)
Air, nitrogen	200	1	100.0	0.5	80.0	0.5	50.0	0.2	40.0	0.2
Argon	200	1	100.0	0.5	80.0	0.5	50.0	0.2	40.0	0.2
Carbon dioxide	120.0	0.5	60.0	0.2	50.0	0.2	30.0	0.1	30.0	0.1
Oxygen	200	1	100.0	0.5	80.0	0.5	50.0	0.2	40.0	0.2
City gas 13A (LNG)	200	1	100.0	0.5	80.0	0.5	50.0	0.2	40.0	0.2
Methane 100%	200	1	100.0	0.5	80.0	0.5	50.0	0.2	40.0	0.2
Propane 100%	60.0	0.2	30.0	0.1	30.0	0.1	20.0	0.1	20.0	0.1
Butane 100%	50.0	0.2	30.0	0.1	20.0	0.1	20.0	0.1	10.0	0.1
	Range setup=5		Range setup=6		Range setup=7		Range setup=8		Range setup=9	
	Full-scale (mL/min)	Resolution (mL/min)	Full-scale (mL/min)	Resolution (mL/min)	Full-scale (mL/min)	Resolution (mL/min)	Full-scale (mL/min)	Resolution (mL/min)	Full-scale (mL/min)	Resolution (mL/min)
Air, nitrogen	40.0	0.2	30.0	0.1	30.0	0.1	30.0	0.1	20.0	0.1
Argon	40.0	0.2	30.0	0.1	30.0	0.1	30.0	0.1	20.0	0.1
Carbon dioxide	30.0	0.1	20.0	0.1	20.0	0.1	20.0	0.1	20.0	0.1
Oxygen	40.0	0.2	30.0	0.1	30.0	0.1	30.0	0.1	20.0	0.1
City gas 13A (LNG)	40.0	0.2	30.0	0.1	30.0	0.1	30.0	0.1	20.0	0.1
Methane 100%	40.0	0.2	30.0	0.1	30.0	0.1	30.0	0.1	20.0	0.1
Propane 100%	20.0	0.1	10.0	0.1	10.0	0.1	10.0	0.1	10.0	0.1
Butane 100%	10.0	0.1	10.0	0.1	10.0	0.1	10.0	0.1	10.0	0.1

● CMQ9500

	Range setup=0		Range setup=1		Range setup=2		Range setup=3		Range setup=4	
	Full-scale (L/min)	Resolution (L/min)	Full-scale (L/min)	Resolution (L/min)	Full-scale (L/min)	Resolution (L/min)	Full-scale (L/min)	Resolution (L/min)	Full-scale (L/min)	Resolution (L/min)
Air, nitrogen	0.500	0.002	0.250	0.001	0.200	0.001	0.160	0.001	(100.0)	(0.5)
Argon	0.500	0.002	0.250	0.001	0.200	0.001	0.160	0.001	(100.0)	(0.5)
Carbon dioxide	0.300	0.001	0.160	0.001	0.120	0.001	(100.0)	(0.5)	(60.0)	(0.2)
Oxygen	0.500	0.002	0.250	0.001	0.200	0.001	0.160	0.001	(100.0)	(0.5)
City gas 13A (LNG)	0.500	0.002	0.250	0.001	0.200	0.001	0.160	0.001	(100.0)	(0.5)
Methane 100%	0.500	0.002	0.250	0.001	0.200	0.001	0.160	0.001	(100.0)	(0.5)
Propane 100%	0.160	0.001	(80.0)	(0.5)	(60.0)	(0.2)	(50.0)	(0.2)	(30.0)	(0.1)
Butane 100%	0.120	0.001	(60.0)	(0.2)	(50.0)	(0.2)	(40.0)	(0.2)	(30.0)	(0.1)
	Range setup=5		Range setup=6		Range setup=7		Range setup=8		Range setup=9	
	Full-scale (L/min)	Resolution (L/min)	Full-scale (L/min)	Resolution (L/min)	Full-scale (L/min)	Resolution (L/min)	Full-scale (L/min)	Resolution (L/min)	Full-scale (L/min)	Resolution (L/min)
Air, nitrogen	(100.0)	(0.5)	(80.0)	(0.5)	(80.0)	(0.5)	(60.0)	(0.2)	(50.0)	(0.2)
Argon	(100.0)	(0.5)	(80.0)	(0.5)	(80.0)	(0.5)	(60.0)	(0.2)	(50.0)	(0.2)
Carbon dioxide	(60.0)	(0.2)	(50.0)	(0.2)	(50.0)	(0.2)	(40.0)	(0.2)	(30.0)	(0.2)
Oxygen	(100.0)	(0.5)	(80.0)	(0.5)	(80.0)	(0.5)	(60.0)	(0.2)	(50.0)	(0.2)
City gas 13A (LNG)	(100.0)	(0.5)	(80.0)	(0.5)	(80.0)	(0.5)	(50.0)	(0.2)	(50.0)	(0.2)
Methane 100%	(100.0)	(0.5)	(80.0)	(0.5)	(80.0)	(0.5)	(60.0)	(0.2)	(50.0)	(0.2)
Propane 100%	(30.0)	(0.1)	(30.0)	(0.1)	(30.0)	(0.1)	(20.0)	(0.1)	(20.0)	(0.1)
Butane 100%	(30.0)	(0.1)	(20.0)	(0.1)	(20.0)	(0.1)	(20.0)	(0.1)	(20.0)	(0.1)

Note) The unit for indication is mL/min for the flowrate given in parenthesis.

● CMQ0002

	Range setup=0		Range setup=1		Range setup=2		Range setup=3		Range setup=4	
	Full-scale (L/min)	Resolution (L/min)	Full-scale (L/min)	Resolution (L/min)	Full-scale (L/min)	Resolution (L/min)	Full-scale (L/min)	Resolution (L/min)	Full-scale (L/min)	Resolution (L/min)
Air, nitrogen	2.00	0.01	1.000	0.005	0.800	0.005	0.500	0.002	0.400	0.002
Argon	2.00	0.01	1.000	0.005	0.800	0.005	0.500	0.002	0.400	0.002
Carbon dioxide	1.200	0.005	0.600	0.002	0.500	0.002	0.300	0.001	0.300	0.001
Oxygen	2.00	0.01	1.000	0.005	0.800	0.005	0.500	0.002	0.400	0.002
City gas 13A (LNG)	1.60	0.01	0.800	0.005	0.800	0.005	0.400	0.002	0.400	0.002
Methane 100%	2.00	0.01	1.000	0.005	0.800	0.005	0.500	0.002	0.400	0.002
Propane 100%	0.600	0.002	0.300	0.001	0.300	0.001	0.200	0.001	0.200	0.001
Butane 100%	0.400	0.002	0.200	0.001	0.200	0.001	0.100	0.001	0.100	0.001
	Range setup=5		Range setup=6		Range setup=7		Range setup=8		Range setup=9	
	Full-scale (L/min)	Resolution (L/min)	Full-scale (L/min)	Resolution (L/min)	Full-scale (L/min)	Resolution (L/min)	Full-scale (L/min)	Resolution (L/min)	Full-scale (L/min)	Resolution (L/min)
Air, nitrogen	0.400	0.002	0.300	0.001	0.300	0.001	0.300	0.001	0.200	0.001
Argon	0.400	0.002	0.300	0.001	0.300	0.001	0.300	0.001	0.200	0.001
Carbon dioxide	0.300	0.001	0.200	0.001	0.200	0.001	0.200	0.001	0.200	0.001
Oxygen	0.400	0.002	0.300	0.001	0.300	0.001	0.300	0.001	0.200	0.001
City gas 13A (LNG)	0.400	0.002	0.300	0.001	0.300	0.001	0.300	0.001	0.200	0.001
Methane 100%	0.400	0.002	0.300	0.001	0.300	0.001	0.300	0.001	0.200	0.001
Propane 100%	0.200	0.001	0.100	0.001	0.100	0.001	0.100	0.001	0.100	0.001
Butane 100%	0.100	0.001	0.100	0.001	0.100	0.001	0.100	0.001	0.100	0.001

● CMQ0005

	Range setup=0		Range setup=1		Range setup=2		Range setup=3		Range setup=4	
	Full-scale (L/min)	Resolution (L/min)	Full-scale (L/min)	Resolution (L/min)	Full-scale (L/min)	Resolution (L/min)	Full-scale (L/min)	Resolution (L/min)	Full-scale (L/min)	Resolution (L/min)
Air, nitrogen	5.00	0.02	2.50	0.01	2.00	0.01	1.60	0.01	1.000	0.005
Argon	5.00	0.02	2.50	0.01	2.00	0.01	1.60	0.01	1.000	0.005
Carbon dioxide	3.00	0.01	1.60	0.01	1.200	0.005	1.000	0.005	0.600	0.002
Oxygen	5.00	0.02	2.50	0.01	2.00	0.01	1.60	0.01	1.000	0.005
City gas 13A (LNG)	5.00	0.02	2.50	0.01	2.00	0.01	1.60	0.01	1.000	0.005
Methane 100%	5.00	0.02	2.50	0.01	2.00	0.01	1.60	0.01	1.000	0.005
Propane 100%	1.60	0.01	0.800	0.005	0.600	0.002	0.500	0.002	0.300	0.001
Butane 100%	1.200	0.005	0.600	0.002	0.500	0.002	0.400	0.00	0.300	0.001
	Range setup=5		Range setup=6		Range setup=7		Range setup=8		Range setup=9	
	Full-scale (L/min)	Resolution (L/min)	Full-scale (L/min)	Resolution (L/min)	Full-scale (L/min)	Resolution (L/min)	Full-scale (L/min)	Resolution (L/min)	Full-scale (L/min)	Resolution (L/min)
Air, nitrogen	1.000	0.005	0.800	0.005	0.800	0.005	0.600	0.002	0.500	0.002
Argon	1.000	0.005	0.800	0.005	0.800	0.005	0.600	0.002	0.500	0.002
Carbon dioxide	0.600	0.002	0.500	0.002	0.500	0.002	0.400	0.002	0.300	0.001
Oxygen	1.000	0.005	0.800	0.005	0.800	0.005	0.600	0.002	0.500	0.002
City gas 13A (LNG)	1.000	0.005	0.800	0.005	0.800	0.005	0.600	0.002	0.500	0.002
Methane 100%	1.000	0.005	0.800	0.005	0.800	0.005	0.600	0.002	0.500	0.002
Propane 100%	0.300	0.001	0.300	0.001	0.300	0.001	0.200	0.001	0.200	0.001
Butane 100%%	0.300	0.001	0.200	0.001	0.200	0.001	0.200	0.001	0.200	0.001

● CMQ0020

	Range setup=0		Range setup=1		Range setup=2		Range setup=3		Range setup=4	
	Full-scale (L/min)	Resolution (L/min)	Full-scale (L/min)	Resolution (L/min)	Full-scale (L/min)	Resolution (L/min)	Full-scale (L/min)	Resolution (L/min)	Full-scale (L/min)	Resolution (L/min)
Air, nitrogen	20.0	0.1	10.00	0.05	8.00	0.05	5.00	0.02	4.00	0.02
Argon	20.0	0.1	10.00	0.05	8.00	0.05	5.00	0.02	4.00	0.02
Carbon dioxide	12.00	0.05	6.00	0.02	5.00	0.02	3.00	0.01	3.00	0.01
Oxygen	20.0	0.1	10.00	0.05	8.00	0.05	5.00	0.02	4.00	0.02
City gas 13A (LNG)	20.0	0.1	10.00	0.05	8.00	0.05	5.00	0.02	4.00	0.02
Methane 100%	20.0	0.1	10.00	0.05	8.00	0.05	5.00	0.02	4.00	0.02
Propane 100%	6.00	0.02	3.00	0.01	3.00	0.01	2.00	0.01	2.00	0.01
Butane 100%	4.00	0.02	2.00	0.01	2.00	0.01	1.00	0.01	1.00	0.01
	Range setup=5		Range setup=6		Range setup=7		Range setup=8		Range setup=9	
	Full-scale (L/min)	Resolution (L/min)	Full-scale (L/min)	Resolution (L/min)	Full-scale (L/min)	Resolution (L/min)	Full-scale (L/min)	Resolution (L/min)	Full-scale (L/min)	Resolution (L/min)
Air, nitrogen	4.00	0.02	3.00	0.01	3.00	0.01	3.00	0.01	2.00	0.01
Argon	4.00	0.02	3.00	0.01	3.00	0.01	3.00	0.01	2.00	0.01
Carbon dioxide	3.00	0.01	2.00	0.01	2.00	0.01	2.00	0.01	2.00	0.01
Oxygen	4.00	0.02	3.00	0.01	3.00	0.01	3.00	0.01	2.00	0.01
City gas 13A (LNG)	4.00	0.02	3.00	0.01	3.00	0.01	3.00	0.01	2.00	0.01
Methane 100%	4.00	0.02	3.00	0.01	3.00	0.01	3.00	0.01	2.00	0.01
Propane 100%	2.00	0.01	1.00	0.01	1.00	0.01	1.00	0.01	1.00	0.01
Butane 100%	1.00	0.01	1.00	0.01	1.00	0.01	1.00	0.01	1.00	0.01

● CMQ0050

	Range setup=0		Range setup=1		Range setup=2		Range setup=3		Range setup=4	
	Full-scale (L/min)	Resolution (L/min)	Full-scale (L/min)	Resolution (L/min)	Full-scale (L/min)	Resolution (L/min)	Full-scale (L/min)	Resolution (L/min)	Full-scale (L/min)	Resolution (L/min)
Air, nitrogen	50.0	0.2	25.0	0.1	20.0	0.1	16.0	0.1	10.00	0.05
Argon	50.0	0.2	25.0	0.1	20.0	0.1	16.0	0.1	10.00	0.05
Carbon dioxide	30.0	0.1	16.0	0.1	12.0	0.05	10.0	0.05	6.00	0.02
Oxygen	50.0	0.2	25.0	0.1	20.0	0.1	16.0	0.1	10.00	0.05
City gas 13A (LNG)	50.0	0.2	25.0	0.1	20.0	0.1	16.0	0.1	10.00	0.05
Methane 100%	50.0	0.2	25.0	0.1	20.0	0.1	16.0	0.1	10.00	0.05
Propane 100%	16.0	0.1	8.00	0.05	6.00	0.02	5.00	0.02	3.00	0.01
Butane 100%	10.00	0.05	5.00	0.02	4.00	0.02	4.00	0.02	2.00	0.01
	Range setup=5		Range setup=6		Range setup=7		Range setup=8		Range setup=9	
	Full-scale (L/min)	Resolution (L/min)	Full-scale (L/min)	Resolution (L/min)	Full-scale (L/min)	Resolution (L/min)	Full-scale (L/min)	Resolution (L/min)	Full-scale (L/min)	Resolution (L/min)
Air, nitrogen	10.00	0.05	8.00	0.05	8.00	0.05	6.00	0.02	5.00	0.02
Argon	10.00	0.05	8.00	0.05	8.00	0.05	6.00	0.02	5.00	0.02
Carbon dioxide	6.00	0.02	5.00	0.02	5.00	0.02	4.00	0.02	3.00	0.01
Oxygen	10.00	0.05	8.00	0.05	8.00	0.05	6.00	0.02	5.00	0.02
City gas 13A (LNG)	10.00	0.05	8.00	0.05	8.00	0.05	6.00	0.02	5.00	0.02
Methane 100%	10.00	0.05	8.00	0.05	8.00	0.05	6.00	0.02	5.00	0.02
Propane 100%	3.00	0.01	3.00	0.01	3.00	0.01	2.00	0.01	2.00	0.01
Butane 100%	2.00	0.01	2.00	0.01	2.00	0.01	2.00	0.01	1.00	0.01

External dimensions

Models with integrated display

Unit: mm

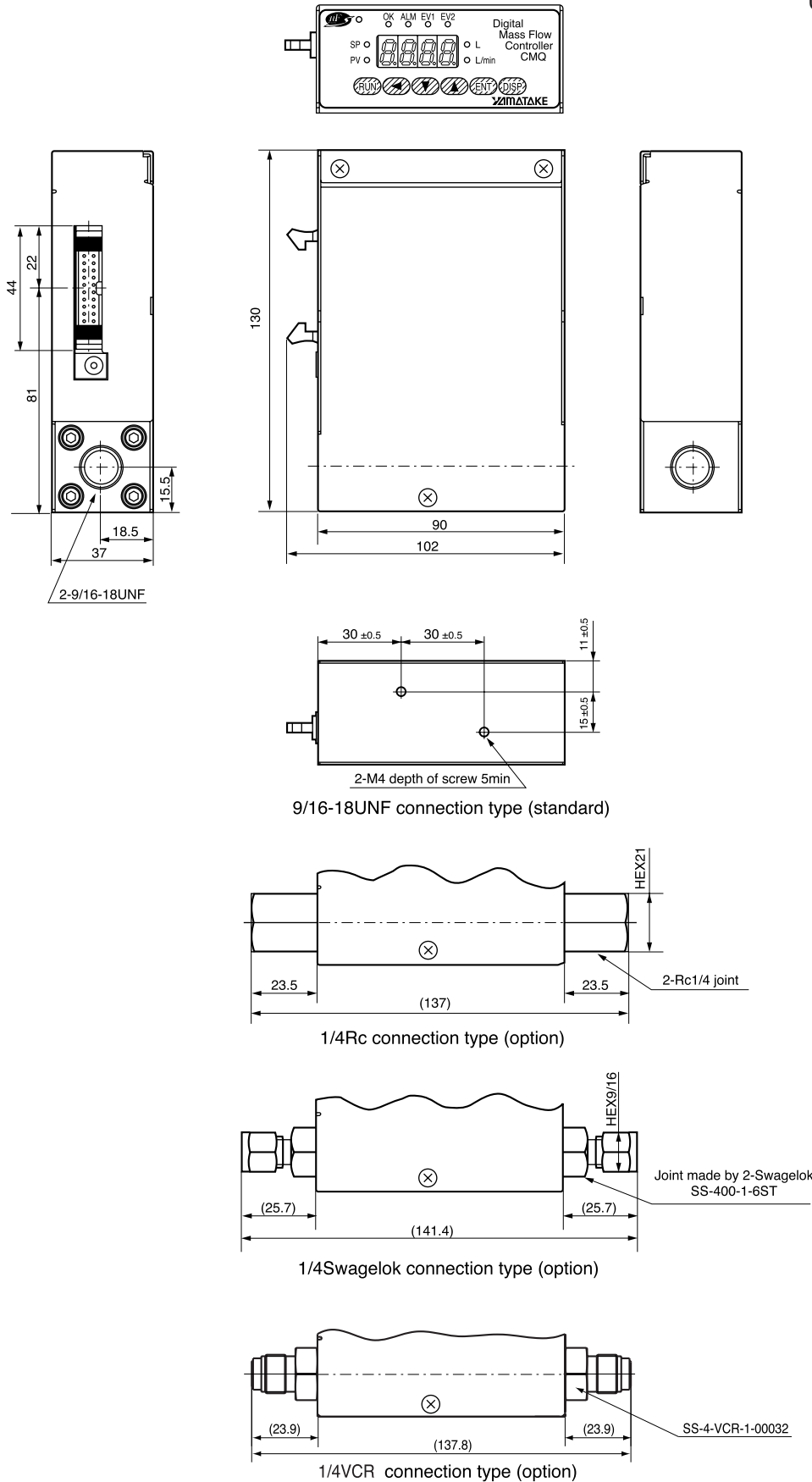

● Model with separate display

Unit: mm

• Body

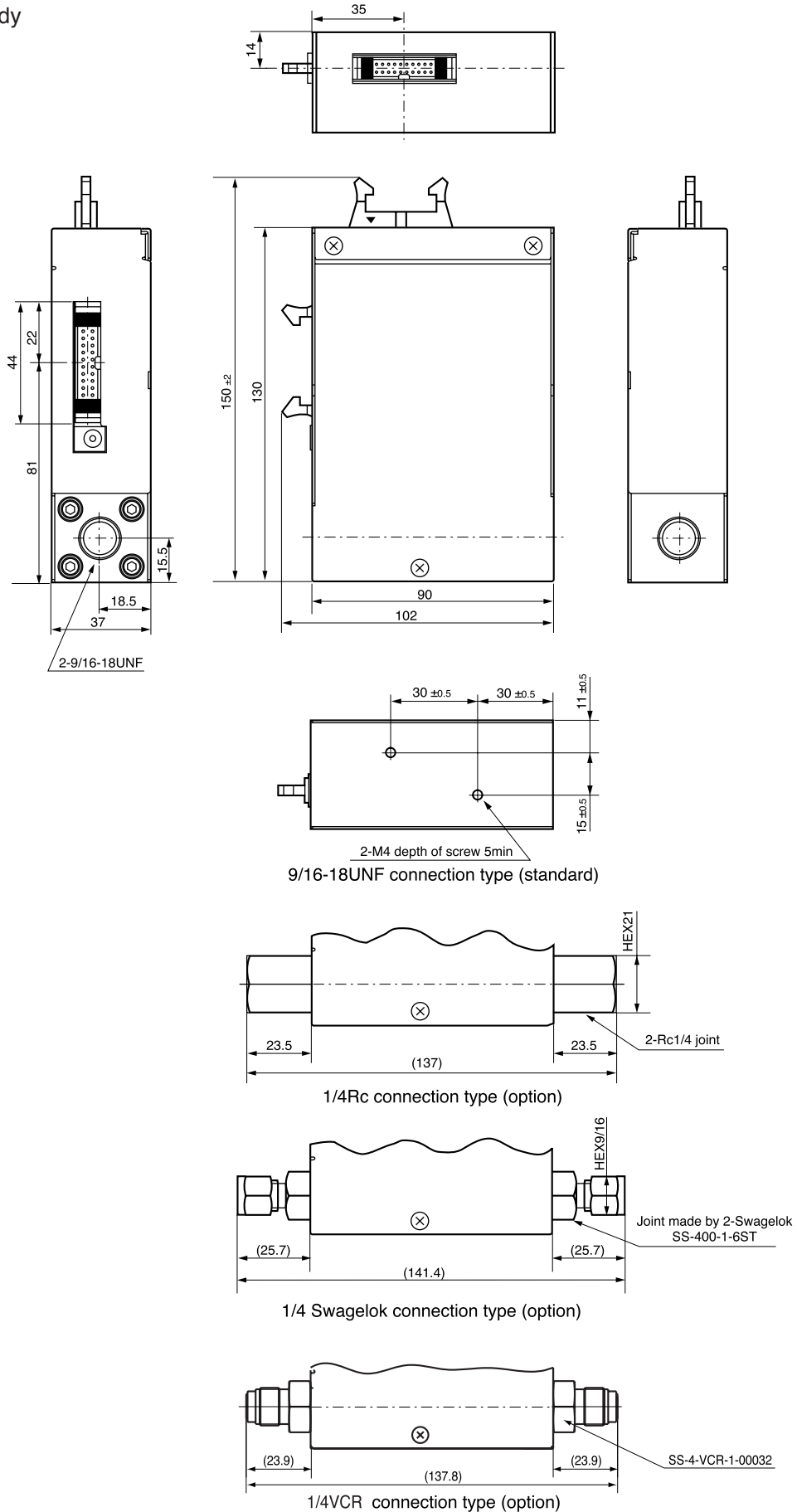

• Display

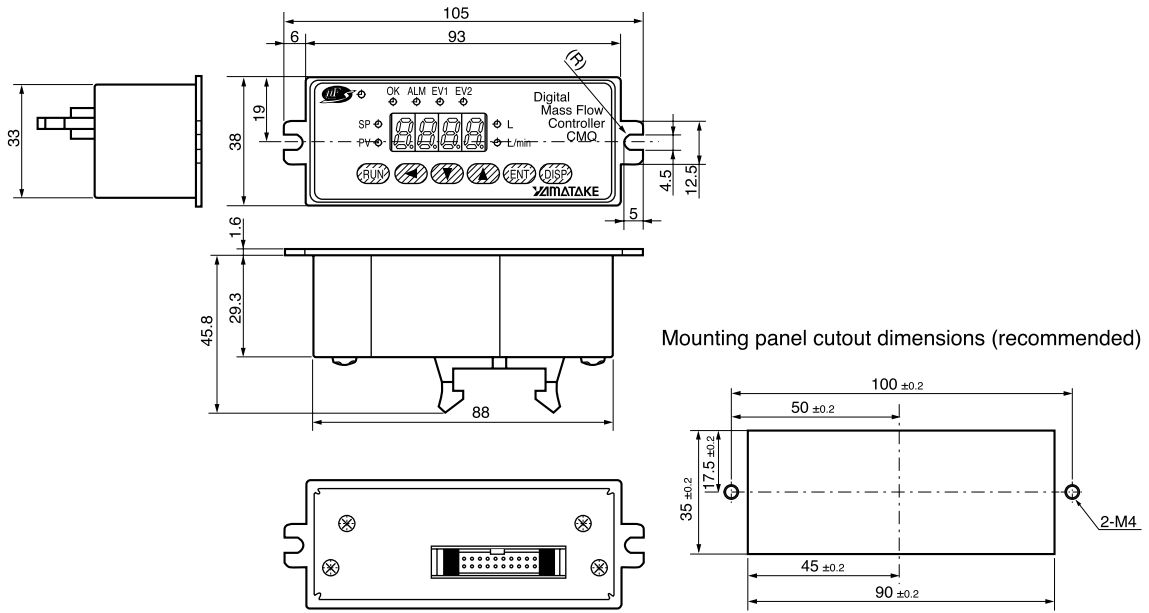

● Cable for connecting display to body

Unit: mm

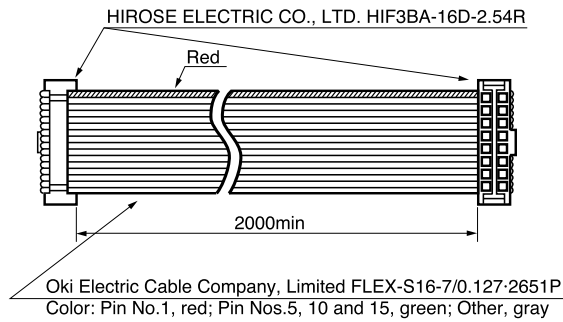

● Cable with special connector 81446681-001

Unit: mm

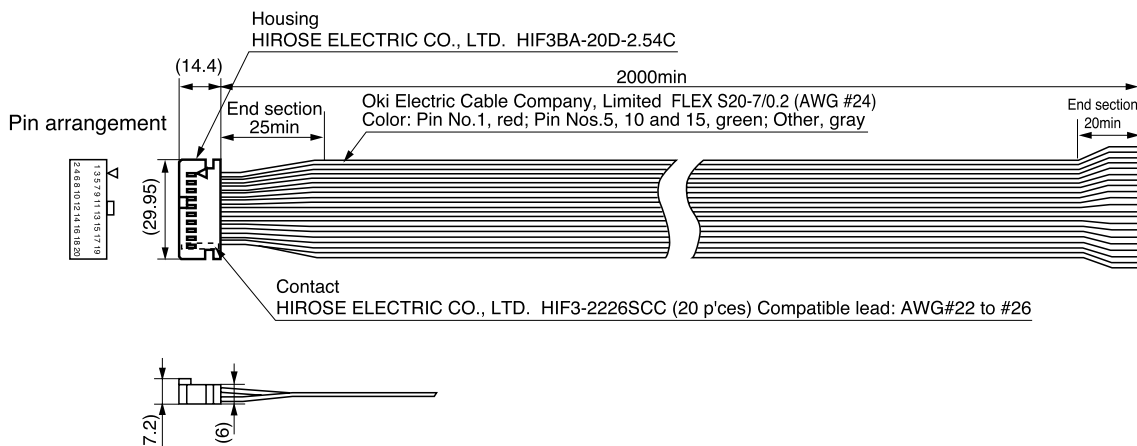

● Potentiometer for setting flowrate 81446683-001

Unit: mm

• Digital dial

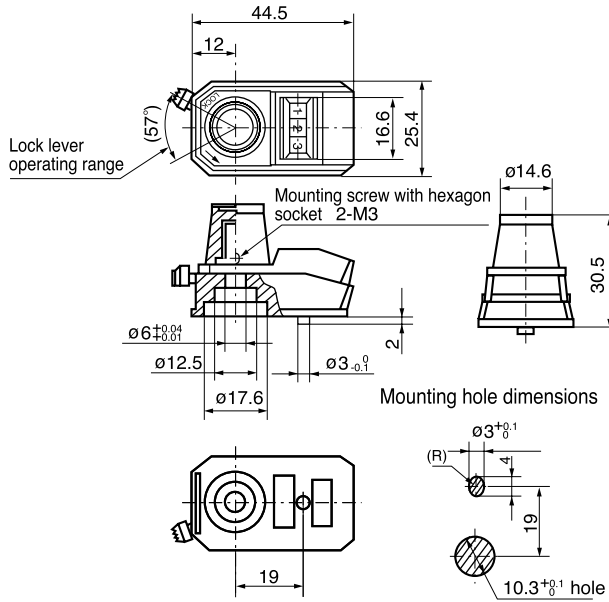

• Potentiometer

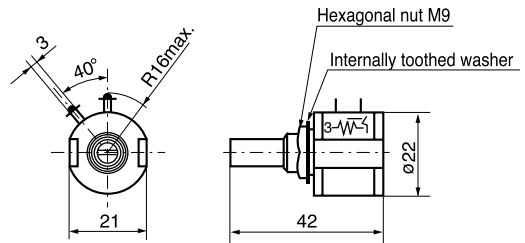

● AC adapter 81446682-001

Unit: mm

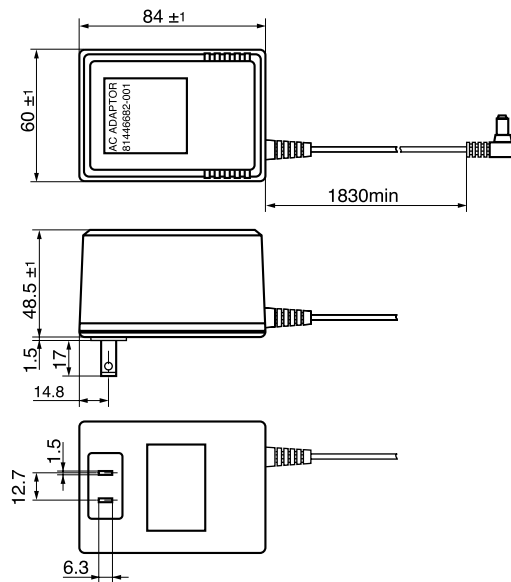

Revision History

Printed Date	Manual Number	Edition	Revised pages	Description
01-07	CP-SP-1112E	1st Edition		
01-10		2nd Edition	Cover, v, 1-1, 1-4 1-5 ii, 3-1 1-4, 1-5 3-5 4-1 5-2 7-2	Changed by model number addition. Adds about shutoff valve. "Traceability Certificate provided" was changed to "Complying with the traceability certification". Contact type name changed. "(5) Valve drive current value" and Note 3 was added. C05, C06 Remarks corrected. External switching input specification corrected. Allowable ON residual voltage Max. 0V to 1.0V Allowable ON leakage current to Allowable <u>OFF</u> leakage current.
02-11		3rd Edition	ii, iii 1-1 1-2 to 1-3 1-4 3-1 4-4 to 4-7 5-2 5-3 5-4 5-5 5-6 5-7 5-8 6-1 6-2 Chapter7.	Model No. (CMQ9200/9500/0002) added. RESTRICTIONS ON USE changed. WARNING and CAUTION changed and added. Description of Features changed. Description of Functions changed and added. Model selection guide changed, old 1-4page deleted. WARNING and CAUTION changed and added. Old 4-4 page deleted because all models without display have been deleted, Old 4-5 to 4-8 page. 4 setup items added in C-08, 7 to 10. 1 setup item added in C-09, 5. 4 setup items added in C-10 to C-12, 8 to 11. 1 setup item changed in C-18, 1. C-22 to C-26 added. Old 5-5 page. Parameter setup item list No.13 and 14 added, Old 5-6 page. Description of Note3 added, Note 5 added, Old 5-7 page. Handling Precautions added. Description added to the Alarm Code AL81 Cause column. Description added to item (2). Node added. Model number added. Overall layout changed due to the addition of "Full scale flowrate and resolution at flowrate range change".
03-06		4th Edition	iii 1-3 1-4 3-1	RESTRICTIONS ON USE changed. Item 1 of CAUTION SS-400-VCR-1-00032SC11 to SS-4-VCR-1-00032SC11 changed. Item 5 of "EV1", "EV2"(event) lamp lighting / output: The number of modes changed to 4 by adding "control or fully open". SP ramp control function and analog optional scaling function added. Item 6 of CAUTION SS-400-VCR-1-00032SC11 to SS-4-VCR-1-00032SC11 changed.

Printed Date	Manual Number	Edition	Revised pages	Description
03-06	CP-SP-1112E	4th Edition	3-8 3-9 5-3 5-5 5-6 5-7 5-8 5-9 6-2 7-4, 7-5 7-5	Event output/Alarm output wiring drawing: Signal name added. The power supply for ALM OUT and D.GND changed to the model complying with CE. The power supply for POWER GND and POWER(15 to 24V) changed to the model complying with CE. Description added to the Setup No.7 of C-12 and the Remarks Item 7. C27 added. C28 added, Old 5-5 page. Old 5-6 page. No.15 to 17 added, Old 5-6 page. Note 5: "9 to 10" changed to "8 to 10". Note 6 to Note 9 added, Old 5-8 page. The item of "Flowrate does not stabilize " in the table of "Other trouble": Description added to the item 3 in "Remedy" column. Applicable standard added. Indication accuracy of CMQ0005 and CMQ0020 changed.

YAMATAKE

Yamatake Corporation
Advanced Automation Company
International Business Headquarters

Totate International Building

2-12-19 Shibuya Shibuya-ku

Tokyo 150-8316 Japan

URL: <http://www.yamatake.com>

This has been printed on recycled paper. (01)

Specifications are subject to change without notice.

Printed in J apan.

1st Edition: Issued in J uly, 2001(W)

4th Edition: Issued in J une, 2003(W)