



CMG Series Gas Flow Monitor User's Manual



Thank you for purchasing the CMG Series Gas Flow Monitor.

This manual contains information for ensuring the correct use of the CMG Series. It also provides necessary information for installation, maintenance, and troubleshooting.

This manual should be read by those who design and maintain equipment that uses the CMG Series. Be sure to keep this manual nearby for handy reference.

Yamatake Corporation

RESTRICTIONS ON USE

This product has been designed, developed and manufactured for general-purpose application in machinery and equipment.

Accordingly, when used in applications outlined below, special care should be taken to implement a fail-safe and/or redundant design concept as well as a periodic maintenance program.

- Safety devices for plant worker protection
- Start/stop control devices for transportation and material handling machines
- Aeronautical/aerospace machines
- Control devices for nuclear reactors

Never use this product in applications where human safety may be put at risk.

NOTICE

Be sure that the user receives this manual before the product is used.

Copying or duplicating this user's manual in part or in whole is forbidden. The information and specifications in this manual are subject to change without notice.

Considerable effort has been made to ensure that this manual is free from inaccuracies and omissions. If you should find an error or omission, please contact Yamatake Corporation.

In no event is Yamatake Corporation liable to anyone for any indirect, special or consequential damages as a result of using this product.

©2005 Yamatake Corporation ALL RIGHTS RESERVED

The μF^{TM} , CMG^{TM} are trademark of Yamatake Corporation in Japan.

SAFETY PRECAUTIONS

■ About Icons

The safety precautions described in this manual are indicated by various icons. Please be sure you read and understand the icons and their meanings described below before reading the rest of the manual.

Safety precautions are intended to ensure the safe and correct use of this product, to prevent injury to the operator and others, and to prevent damage to property. Be sure to observe these safety precautions.



 **WARNING**

Warnings are indicated when mishandling this product might result in death or serious injury.







 **CAUTION**

Cautions are indicated when mishandling this product might result in minor injury to the user, or only physical damage to the product.









■ Examples

	Use caution when handling the product.
	The indicated action is prohibited.
	Be sure to follow the indicated instructions.

WARNING

	When using combustible gas, install the device upstream of the safety shut off valve. If air somehow enters the piping, and the sensor makes a spark due to some cause like a lightning strike when an explosive mixture is present, an explosion could occur inside the pipe.
	On flanged models, do not use the device or installed pipes as a footrest. Doing so might damage the device or piping, or cause a slip which might result in injury.
	Flanged models are heavy. Dropping them on your feet may cause injury.
	The device is intended for use with city gas 13A, air, propane, and butane. Do not use the device for other types of gases. Use of the gases having an ignition temperature lower than 365°C may cause an internal pipe explosion. A heater incorporated in a sensor could act as an ignition source if air has entered the piping and explosive mixed gas is produced.
	Use the analog outputs and alarm contact outputs on the device for monitoring the gas flow rate of a burner or other equipment. Do not use these outputs in applications where safety will be impaired when an analog output abnormality or alarm contact output malfunction occurs.
	Before wiring the device, be sure to turn the power OFF. Failure to do so might cause electric shock.

CAUTION

	This device is a precision instrument. Do not drop it nor subject it to shock. Doing so might damage the device.
	Do not peel off the pipe connection port seals until immediately before you connect the piping. Doing so might allow foreign objects to enter the connector port and cause defective operation.
	If pipes may contain rust, welding fumes, slag, water droplets, oil mist or dust, install a filter upstream to prevent foreign matter from entering the device. Foreign matter may cause faulty operation.
	When wiring, take care not to tug on the display. The components inside might become damaged.
	When replacing a fuse, be sure the replacement fuse has the correct amperage rating. Use of a fuse with the wrong rating will prevent the safety circuit from functioning properly.
	Be sure to check that the wiring is correct before you turn the power ON. Incorrect wiring may cause damage or malfunction.
	Connect the power supply last. Otherwise touching terminals by mistake may cause electric shock or damage the device.
	Make sure that the load to be connected to terminals does not exceed the rating indicated in the specifications.

CAUTION



Supply power at the voltage indicated on the model number label on the device.



Take the necessary countermeasures with the instrumentation to prevent the occurrence of backfire and to avoid any influence to the device even if backfiring occurs. Pressure increase in the piping or fire caused by backfire of the burner could damage the device.



When disposing of the device, observe local regulations.

Conventions Used in This Manual

The following conventions are used in this manual:



Handling Precautions:

Handling Precautions indicate items that the user should pay attention to when handling the CMG Series.



Note:

Notes indicate information that might benefit the user.

(1), (2), (3):

Numbers in parentheses indicate steps in a sequence or parts of an explanation.

Contents

SAFETY PRECAUTIONS Conventions Used in This Manual

Chapter 1. INTRODUCTION

- Introduction..... 1
- Features 1
- Model selection guide..... 2

Chapter 2. NAMES AND FUNCTIONS OF PARTS

Chapter 3. MOUNTING AND WIRING

- Mounting..... 6
- Pipes..... 7
- Wiring..... 12

Chapter 4. OPERATION

- Displaying the flow rate..... 15
- Resetting alarms..... 16
- Resetting the integrated flow rate 16
- Displaying the total flow rate 17

Chapter 5. APPLICATION OPERATION

- 5-1 Function Setup 18
 - Setting operation 18
 - Function setup item list..... 19
- 5-2 Parameter Setup..... 20
 - Setting operation 20
 - Parameter setup item list..... 21

Chapter 6. MAINTENANCE AND TROUBLESHOOTING

- Remedying trouble 23
- How to replace the fuse..... 24

Chapter 7. SPECIFICATIONS

- CMG Series specifications..... 25
- Individual CMG model specifications..... 26
- Pressure loss..... 28
- External dimensions..... 30

Chapter 1. INTRODUCTION

■ Introduction

The CMG Gas Flow Monitor is a flowmeter for measuring the fuel flow rate of gas burners. It uses the Micro Flow sensor chip, a thermal mass flow sensor made using Yamatake proprietary technology.

The CMG measures and displays the instantaneous and integrated flow rate in normal standard state* without the need for temperature and pressure conversion. Other functions include alarm contact output, analog output of instantaneous flow rate, and open collector output of totalizer pulse or event output.

These functions enable fine-grained air-fuel ratio management of individual burners and flow rate management of combustion equipment.

* Factory setting is 0°C, 101.325kPa (1 atmosphere). (The reference temperature can be selected from 5°C, 10°C, 15°C, 20°C and 25°C according to the function settings.)

■ Features

- Installation of the compact and high-precision CMG is simple. It can be mounted in any direction, as the direction of the display can be changed.
- Gas flow rate can be measured and managed easily on the digital flow rate display and Hi, Lo, OVER and ALARM LED displays.
- Output of the gas flow rate upper/lower limit settings and analog output of instantaneous flow rate are convenient for panel display or flow rate management purposes.
- Fuel usage can be easily understood because the instantaneous flow rate and integrated flow rate displays can be switched by one-touch operation. The total flow rate since this device was installed can be displayed.
- Compensation of display values is not needed even if temperature and pressure change as the measurement method used is mass flow.
- A bypass structure using an orifice enables low pressure loss, and prevents the influence of mist, etc.
- Self-diagnostic functions simplify remedies during troubleshooting.

■ Model selection guide

Model selection guide

CMG I II III IV V VI VII VIII IX

● Air model

Basic model No.	I	II	III	IV	V	VI	VII	VII	IX	Description
	Pipe size	Pipe shape	Gas type	Flow range	Output	Pressure	Comm- nication	Power supply	Additional processing	
CMG										Gas flow monitor
	15									15A (1/2B)
	25									25A (1B)
	40									40A (1 1/2B)
	50									50A (2B)
		0								Rc thread
		1								JIS 10K flange (40A, 50A only)
			A							Air
				004						4m ³ /h (normal) (CMG15) *1
				010						10m ³ /h (normal) (CMG25) *1
				030						30m ³ /h (normal) (CMG25) *1
				080						80m ³ /h (normal) (CMG40, 50) *1
				150						150m ³ /h (normal) (CMG40, 50) *1
					0					1 to 5V output (4, 10, 30m ³ /h only) *3
					1					4 to 20mA + event output
						0				Low pressure (Rc screw only) *2
						1				Medium pressure (CMG25,40,50 of Rc screw) Medium pressure (CMG40,80 of JIS 10K flange) *2
							0			Not available
								0		24Vdc
								1		100Vac (50/60Hz)
								2		200Vac (50/60Hz)
									00	None
									D0	Inspection certificate provided
									Y0	Traceability certificate provided

● Natural gas (13A) model (LNG CH₄: 88%)

Basic model No.	I	II	III	IV	V	VI	VII	VII	IX	Description
	Pipe size	Pipe shape	Gas type	Flow range	Output	Pressure	Comm- nication	Power supply	Additional processing	
CMG										Gas flow monitor
	15									15A (1/2B)
	25									25A (1B)
	40									40A (1 1/2B)
	50									50A (2B)
		0								Rc thread
		1								JIS 10K flange (40A, 50A only)
			N							Natural gas 13A
				004						4m ³ /h (normal) (CMG15) *1
				010						10m ³ /h (normal) (CMG25) *1
				030						30m ³ /h (normal) (CMG25) *1
				080						80m ³ /h (normal) (CMG40, 50) *1
				150						150m ³ /h (normal) (CMG40, 50) *1
					0					1 to 5V output (4, 10, 30m ³ /h (norm.) only)*3
					1					4 to 20mA + event output
						0				Low pressure (Rc screw only) *2
						1				Medium pressure (JIS 10K flange only) *2
							0			Not available
								0		24Vdc
								1		100Vac (50/60Hz)
								2		200Vac (50/60Hz)
									00	None
									D0	Inspection certificate provided
									Y0	Traceability certificate provided

● Propane model

Basic model No.	I Pipe size	II Pipe shape	III Gas type	IV Flow range	V Output	VI Pressure	VII Comm- nication	VIII Power supply	IX Additional processing	Description
CMG										Gas flow monitor
	15									15A (1/2B)
	25									25A (1B)
	40									40A (1 1/2B)
	50									50A (2B)
		0								Rc thread
			P							Propane
				002						2m ³ /h (normal) (CMG15) *1
				004						4m ³ /h (normal) (CMG25) *1
				010						10m ³ /h (normal) (CMG25) *1
				025						25m ³ /h (normal) (CMG40, 50) *1
				050						50m ³ /h (normal) (CMG40, 50) *1
					0					1 to 5V output (2, 4, 10m ³ /h(normal) only)*3
					1					4 to 20mA + event output
						0				Low pressure *2
							0			Not available
								0		24Vdc
								1		100Vac (50/60Hz)
								2		200Vac (50/60Hz)
									00	None
									D0	Inspection certificate provided
									Y0	Traceability certificate provided

● Butane model

Basic model No.	I Pipe size	II Pipe shape	III Gas type	IV Flow range	V Output	VI Pressure	VII Comm- nication	VIII Power supply	IX Additional processing	Description
CMG										Gas flow monitor
	15									15A (1/2B)
	25									25A (1 B)
	40									40A (1 1/2B)
	50									50A (2 B)
		0								Rc thread
			B							Butane (butane 75%, propane 25%)
				001						1m ³ /h (normal) (CMG15) *1
				003						3m ³ /h (normal) (CMG25) *1
				008						8m ³ /h (normal) (CMG25) *1
				020						20m ³ /h (normal) (CMG40, 50) *1
				040						40m ³ /h (normal) (CMG40, 50) *1
					0					1 to 5V output (1, 3, 8m ³ /h(norm.) only) *3
					1					4 to 20mA + event output
						0				Low pressure *2
							0			Not available
								0		24Vdc
								1		100Vac (50/60Hz)
								2		200Vac (50/60Hz)
									00	None
									D0	Inspection certificate provided
									Y0	Traceability certificate provided

*1 "Normal" refers to the volumetric flow rate (m³/h) after converting to 0°C, 101.325kPa (1 atmosphere).

*2 For the selection of a medium pressure model, refer to "When selecting a medium pressure model for air and natural gas (13A)" on page 27.

*3 The 1-5V output model does not have an event output. For use of the integrated pulse output, integrated event output and upper/lower limit alarm, select a 4-20mA model.

Chapter 2. NAMES AND FUNCTIONS OF PARTS

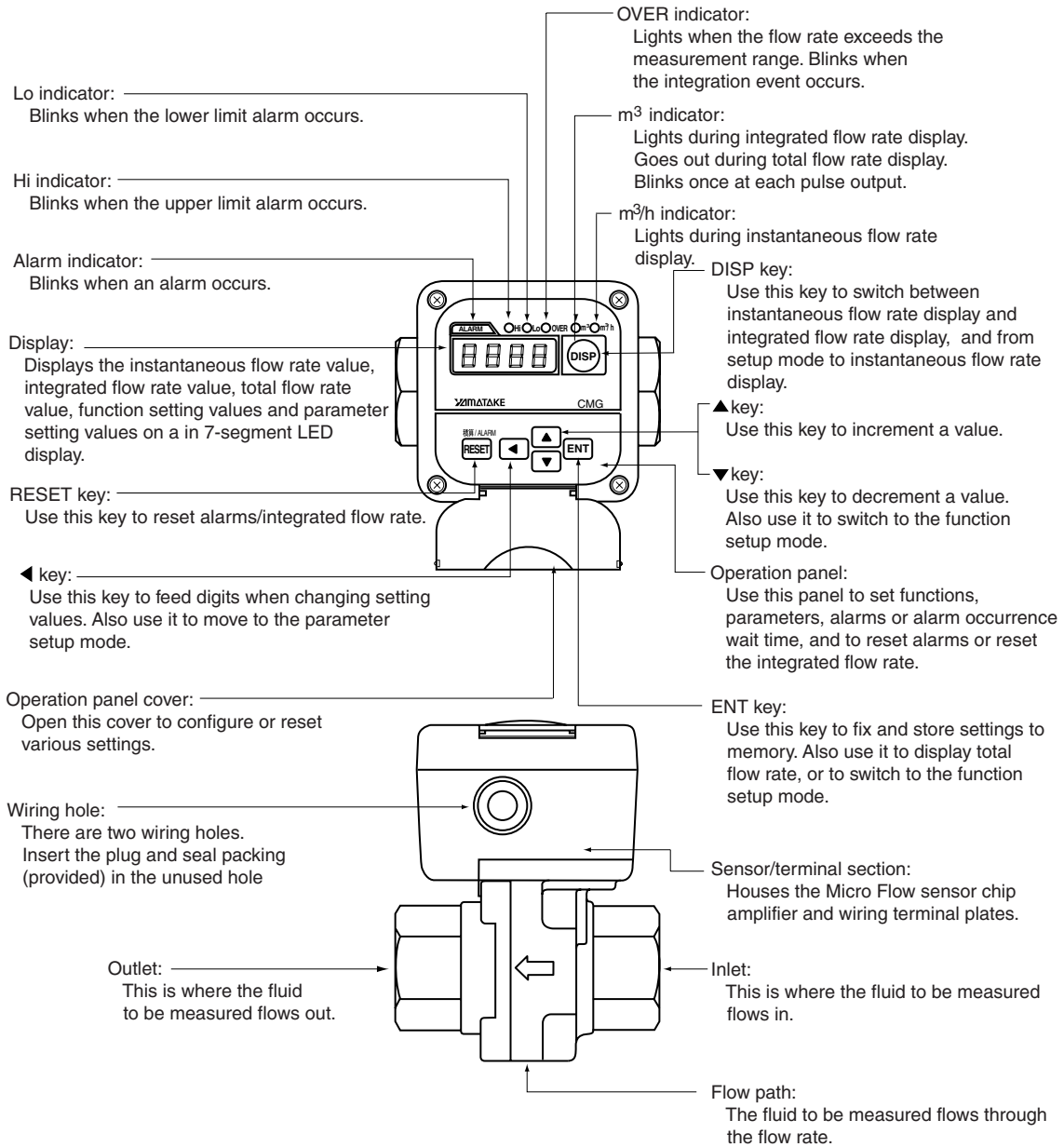

Fuse position

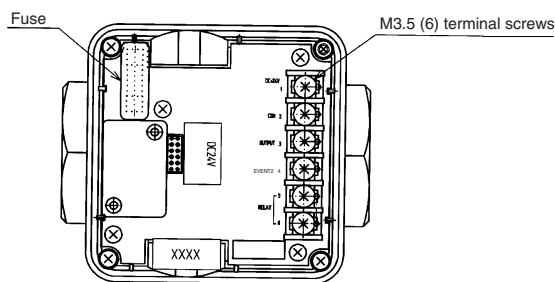

24Vdc power supply model

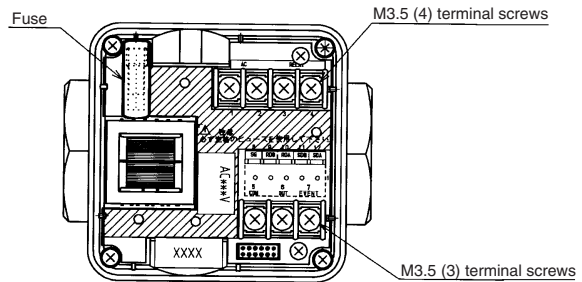

AC power supply model

Chapter 3. MOUNTING AND WIRING

WARNING



When using combustible gas, install the device upstream of the safety shut off valve. If air somehow enters the piping, and the sensor makes a spark due to some cause like a lightning strike when an explosive mixture is present, an explosion could occur inside the pipe.



On flanged models, do not use the device or installed pipes as a footrest. Doing so might damage the device or piping, or cause a slip which might result in injury.



Flanged models are heavy. Dropping them on your feet may cause injury.

Handling Precautions

- When carrying the device, hold it by the flow path section. Holding it by the sensor/terminal section may damage the device.
- This device is a precision instrument. Do not drop it or subject it to shock. Doing so might damage the device.
- If the CMG model has a threaded pipe connection, when connecting the piping fasten the flow inlet/outlet section, and then screw in the pipe side to connect the piping.
- When connecting a flanged device, first check that the piping is not tilted or off center before installing. Failure to do so might cause leakage.
- To prevent vibration of the device, attach the pipe securely.
- Do not peel the protective seals from the display before use. When performing work on the device, tools may accidentally bump against the display and scratch it.
- When using the device outdoors, mount it out of the direct sunlight and in a location where it is not splashed directly by rain.
- If the piping may contain rust, oil mist, dust, or powder, be sure to provide a strainer or filter upstream to prevent foreign matter from entering the device. Foreign matter flowing into the device might result in faulty operation.
- When wiring the device, take care not to tug on the display. The internal connections might become damaged.
- Wire 1-5V output, 4-20mA output, open collector output, and communications separately from the power line and power supply leads. Do not wire these outputs in the same conduit as the power line and power supply leads. Doing so might cause malfunction.
- Install a switch for shutting off the main power to the device within reach of the person operating the device.
- The common mode voltage between output and ground should be less than 33V RMS, 46.7V at peak or 70Vdc, excluding power supply and relay contact output.

■ Mounting

● Installation site

Avoid mounting the CMG in locations characterized by the following:

1. Operating temperatures that fall below -10°C and rise above 60°C
2. Operating humidity that exceeds 90%RH
3. Sudden changes in temperature and condensation
4. Corrosive gases and flammable gases
5. Abundant conductive substances (e.g., dust, salt or iron dust) or organic solvents
6. Vibration or shock
7. Direct sunlight
8. Direct splashing by rain or water
9. Splashing by fluids (e.g., oil, chemicals)
10. Where it is near the electrical noise source.
11. Strong magnetic or electrical fields
12. Where there is a pulsating flow.
 - 1) One cause is flexible piping (regardless of the material) with an accordion-shape inner surface and a length of 500mm or more. Flexible piping (such as a rubber hose) with a flat inner surface does not cause pulsation.
 - 2) Another cause is a reciprocating or rotary type gas booster or a flow meter having rotary motion like a Roots meter.
13. Where soot or moisture generation in the piping is expected due to fluctuation in gas composition, etc.

● Gas flow

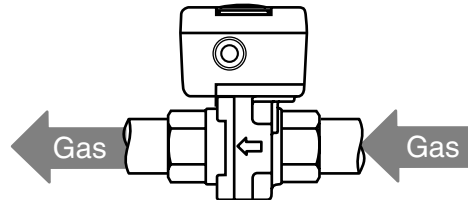

! Handling Precautions

Make sure that the gas flows into the device in the direction indicated by the FLOW arrow on the side of the flow path. Otherwise, the flow rate cannot be measured correctly.

■ Pipes

● Precautions for piping installation

This device is a precision instrument. If foreign matter such as dust, oil mist or water enters the device, it may cause measurement error or faulty operation. When installing piping, be sure to follow the procedures below to prevent foreign matter from entering the device.

1. Before installing the device, be sure to flush the upstream and downstream piping thoroughly to remove welding fume particulate and dust.

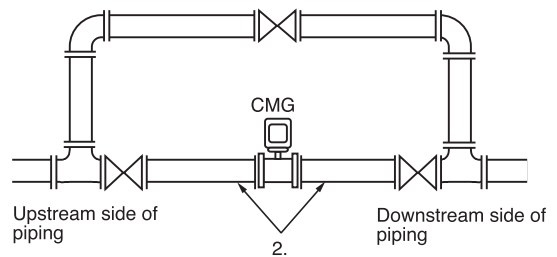

2. Be sure to wipe the inside of the pipe to be directly connected to this device.

3. After the above two operations are complete, check to be sure that there is no welding fume particulate or dust, and then install the device.

! Handling Precautions

If foreign matter cannot be fully eliminated by flushing or wiping, or if the regular presence of foreign matter can be expected, be sure to install a filter. If dust, oil or moisture adheres to the Micro Flow sensor chip, measurement error or faulty operation may result.

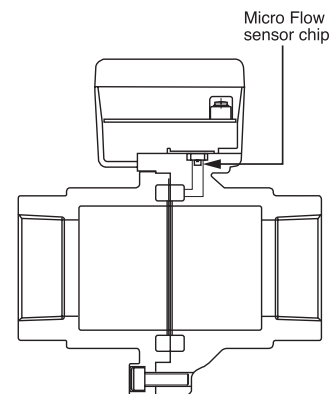

● Filter installation

For applications with propane or butane gas, which regularly contain oil mist, or applications where rust in the piping is expected, be sure to install a filter. Recommended type:

Name: Mist separator

Model No.: MFF100 series

Specifications: For details, refer to;

Yamatake's Specification seat (Japanese)
CP-SS-1824.



● Straight pipe section

To be sure the straight pipe section is long enough, refer to pages 26-27.

● Mounting position

⚠ CAUTION



- Do not mount so that the display is facing down. Doing so might cause error or other malfunction.
- This device can be used with the display facing up $\pm 90^\circ$.

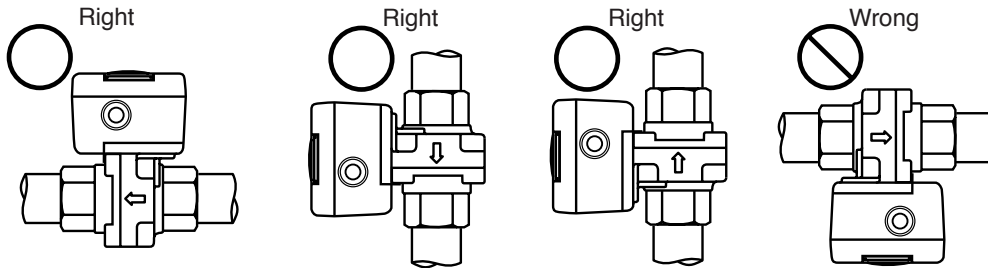

! Handling Precautions

The length of the required straight pipe connection varies according to the model number. For details, see ■ Individual specifications (page 26).

● Screw connection

● Coating sealant

Coat with an appropriate amount of sealant. Do not coat the top two threads of the screw.

Remove any dirt, burrs or piping cutting oil from inside the pipes.

! Handling Precautions

Do not overdo the sealant, and do not allow dirt, burrs or piping cutting oil to enter the pipes, as this might cause measurement error.

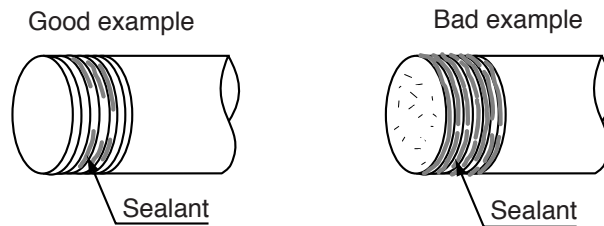

● **Connecting pipes**

Connect pipes while gripping the hexagonal section of the pipe connection port on the body with a wrench.

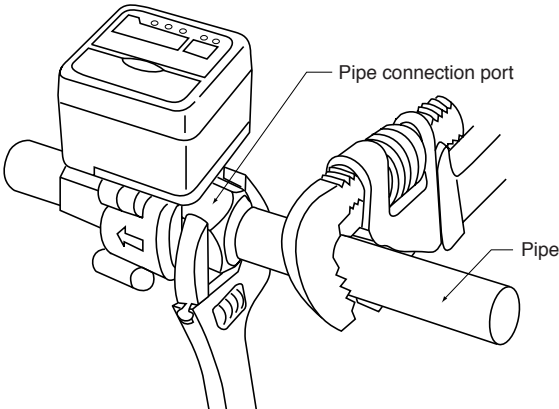

❗ **Handling Precautions**

- Do not grip the display or sensor/terminal section. Doing so might damage the body or cause leakage.
- Do not tighten the pipe at a torque that exceeds the maximum tightening torque.

Model No.	Max. Tightening Torque
CMG150	50N·m
CMG250	125N·m
CMG400	200N·m
CMG500	250N·m

● **Flange connection**

● **Gasket**

A gasket is required for connecting the flange.
The following table shows the internal diameter dimensions of the gasket:

Pipe Size (mm)	Internal Dimensions (mm)
40	37 ± 1
50	49 ± 1

❗ **Handling Precautions**

- If the gasket inner diameter is too small, the flow speed distribution may be disturbed and adversely influence accuracy.
- If the gasket inner diameter is too large, leakage may occur.
- Align the inner diameters of the piping and the flowmeter, and attach so that the gasket does not protrude into the inside of the piping. If it does, leakage might result.

● **Flange Shape**

Use a flange that ensures a large contact area with the gasket.

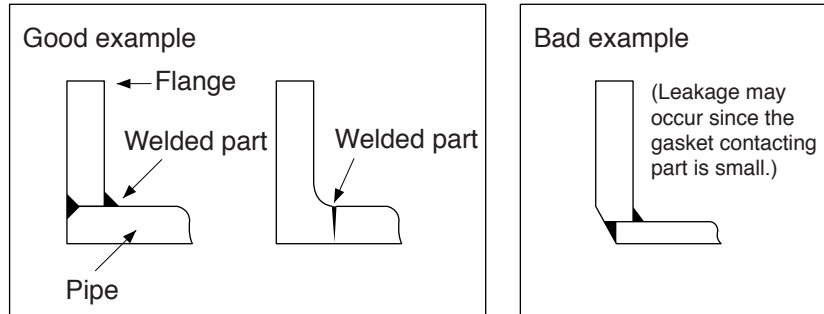

● **Mounting**

The figure below shows how to actually mount the flowmeter. Before installing the flowmeter, be sure to flush the piping to remove any foreign objects inside.

! **Handling Precautions**

Do not flush the piping with the flowmeter attached. Doing so might cause foreign objects to enter the flowmeter and cause error.

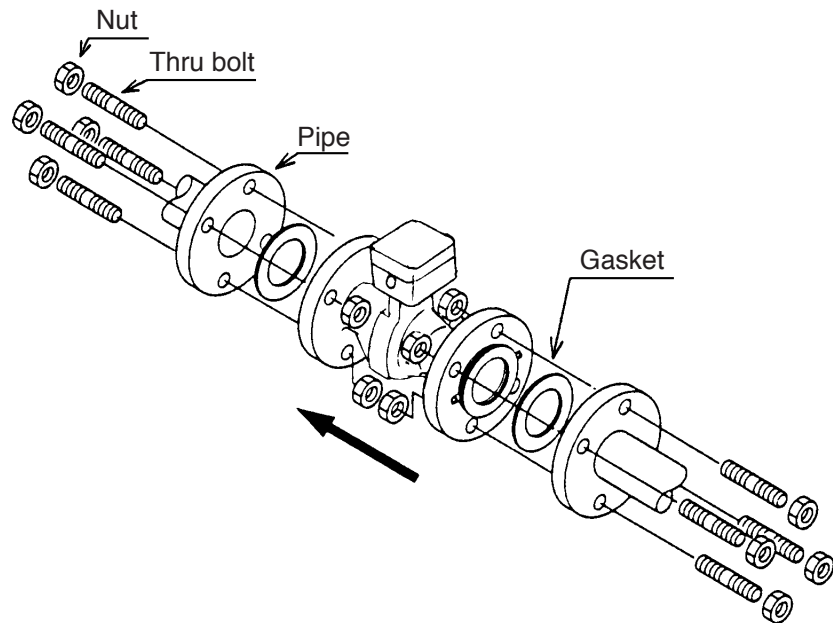

Tighten according to the torque in the following table:

Aperture/Flange Rating		Torque (N•m)
40mm	JIS10K	22 to 32
50mm	JIS10K	24 to 34

! Handling Precautions

- Tighten bolts so that they are uniformly tight. If leakage does not stop after tightening bolts, gradually tighten the bolts more a little at a time.
- Tighten bolts within the specified tightening torque. Otherwise, the bolts may be damaged.
- Do not mount as shown in the following figure. Doing so might cause leakage.

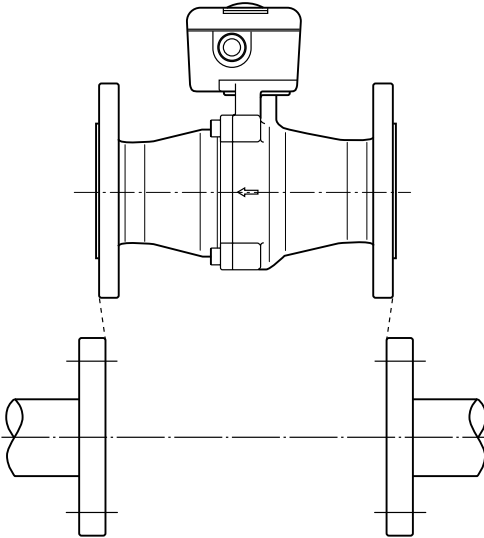

- Do not exert unnecessary force on the narrow section between flange surfaces. Doing so might damage the device.

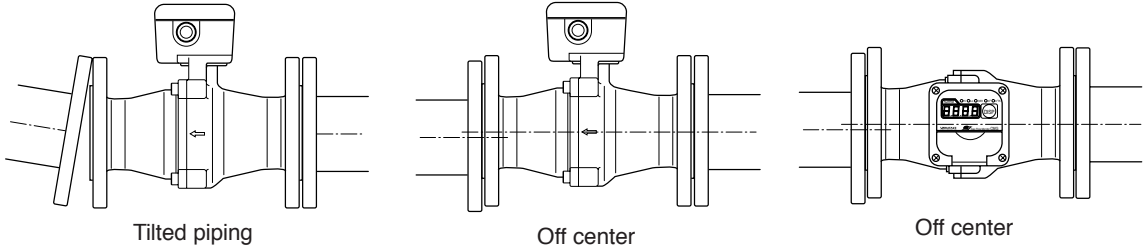

■ Wiring

⚠ CAUTION



Prevent the load connected to the output terminal from exceeding the rating indicated in the specifications. Failure to do so might cause damage.



Be sure to check that the wiring is correct before you turn the power ON. Incorrect wiring might cause damage or malfunction.

The following table describes the meaning of symbols indicated on the terminal layout label on the CMG:

Symbol	Meaning
---	Direct current

● **Removing the operation panel/display**

Required tool: Phillips screwdriver

- (1) Loosen the four screws on the operation panel/display using the Phillips screwdriver.
- (2) Gently lift up the operation panel/display, and disconnect its power lead connectors.

● **Wiring the 24Vdc power supply model**

The following shows wiring of the 24Vdc power supply model and connection names:

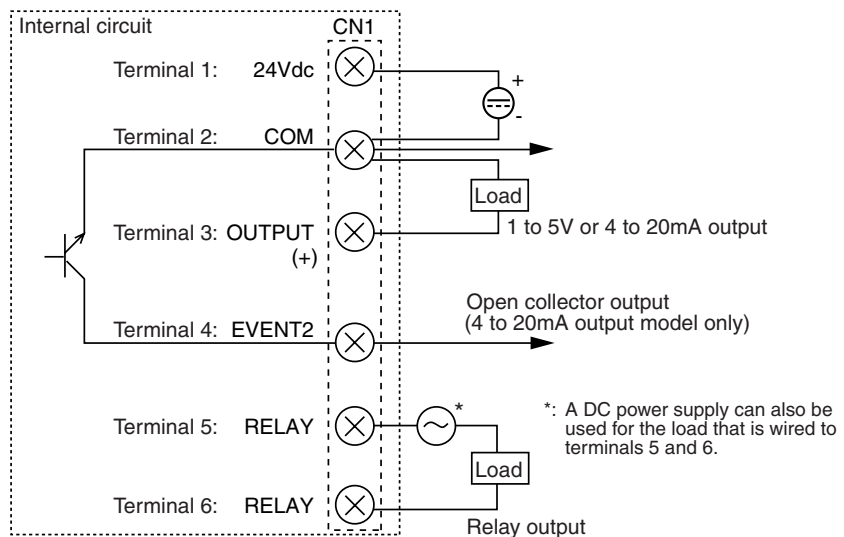

Terminal No.	Connection Name	Description
1	24Vdc	Power supply
2	COM	Common
3	OUTPUT	Analog output (+)
4	EVENT2	Event output 2 NPN open collector, integrated pulse
5	RELAY	Event output 1 contact output (relay output)
6	RELAY	Event output 1 contact output (relay output)

● Wiring the AC power supply model

The following shows wiring of the AC power supply model and connection names:

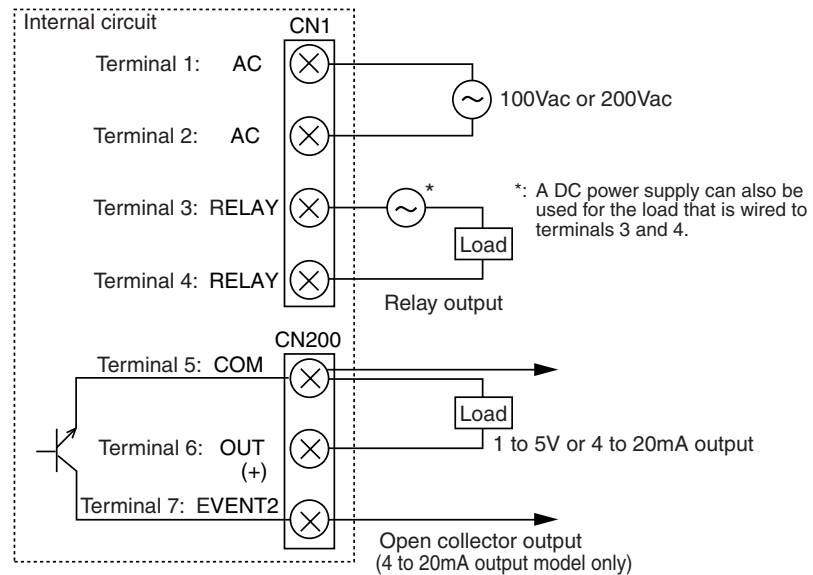

Terminal No.	Connection Name	Description
1	AC	Power supply
2	AC	Power supply
3	RELAY	Event output 1 contact output (relay output)
4	RELAY	Event output 1 contact output (relay output)
5	COM	Common
6	OUT	Analog output (+)
7	EVENT2	Event output 2 NPN open collector, integrated pulse

! Handling Precautions

- Use crimped terminal lugs, which enable a reliable connection to terminals.
- Use crimped terminal lugs that are compatible with M3.5 screws.
- Limit the terminal screw tightening torque to 0.8N•m.
- Use a JIS C 3401 control cable (CVV, etc.) of maximum outer diameter of 2.2mm for wiring.
- If waterproofing is required, be sure to use the seal connector (Yamatake model: PA4-N2, PA4-N4 or equivalent product) for reliable sealing.
- When wiring to terminal 2 (COM) on a 24Vdc power supply type, wire the analog output lead separately from the power lead. Otherwise, a voltage drop caused by the power current may influence the accuracy of the analog output.
- Take care that event output 2 (the open collector output) does not exceed the output rating of this device. When driving a relay, be sure to use one with a built-in coil surge absorption diode. Failure to do so might cause faulty operation.

● **Mounting the operation panel/display**

On this device, the operation panel/display can be rotated up to $\pm 180^\circ$ to an easy-to-view position. Follow the procedure below to mount the operation panel/display:

1. Connect the connectors of the leads from the operation panel/display to the sensor/terminal section.
2. Rotate the display to the most easily visible position.
3. Fasten the operation panel/display onto the sensor/terminal section with screws.

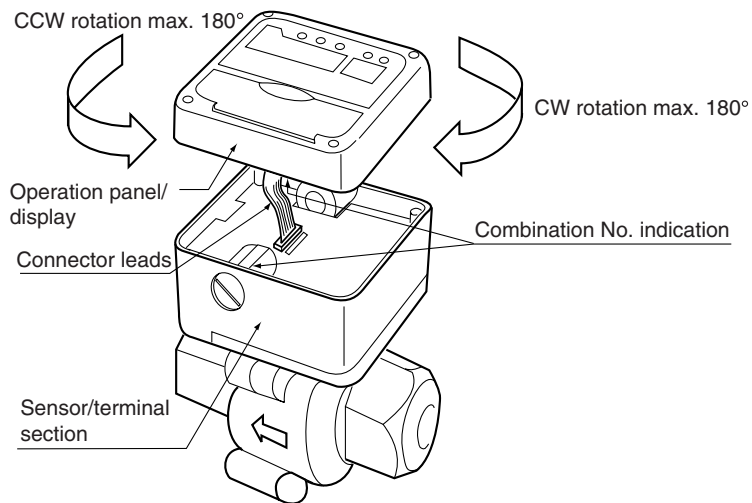

❗ **Handling Precautions**

- The maximum screw tightening torque is 1.0N•m. The IP54 seal might be impaired if screws are too tight or too loose.
- Arrange the leads connecting the sensor/terminal section and the operation panel/display so they are not unnecessarily twisted or pinched when fitting the sections together.
- Prevent the leads connecting the sensor/terminal section and the operation panel/display from being damaged.
- Do not rotate the operation panel/display beyond 180° to the left or right. This section may be rotated to the left or right if it is mounted upside down.
- Use an operation panel/display and a sensor/terminal section with the same combination of combination numbers.

Combination numbers differ from device to device as each device is adjusted individually. If different combination numbers are combined, accuracy can no longer be guaranteed. The combination numbers are each displayed on the operation panel/display and sensor/terminal section.

Chapter 4. OPERATION

⚠ CAUTION



Do not operate the keys with a mechanical pencil, screwdriver or other sharp-tipped object. Doing so might damage the keys.

■ Displaying the flow rate

The following values can be alternated on the 4-digit, 7-segment LED display:

1. Instantaneous flow rate
2. Integrated flow rate

The following shows the operation flow for displaying the flow rate:

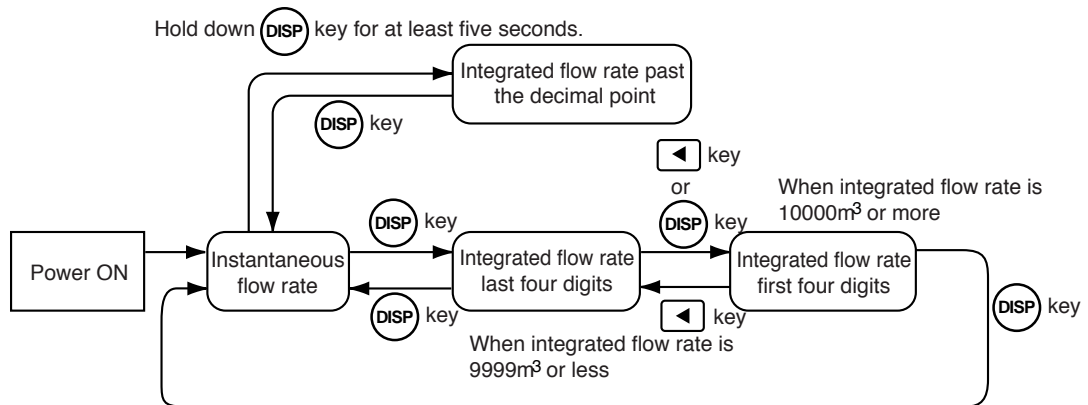

● Displaying the instantaneous flow rate and integrated flow rate

When the power is turned ON, the m^3/h indicator lights to indicate the instantaneous flow rate. To display the integrated flow rate, press the **DISP** key.

- ▶ • The m^3 indicator lights to indicate the integrated flow rate.
- The display is a 4-digit display. However, the integrated flow rate is displayed as eight digits, divided into the first four digits and the last four digits. In all, an integrated flow rate up to **99999999** can be displayed.
- When the last four digits are displayed, the decimal point lights to the right of the last digit.

When the integrated flow rate is **9999** m^3 or less, pressing the **DISP** key again returns the display to the instantaneous flow rate display. When the integrated flow rate is **10000** m^3 or more, pressing the **DISP** key displays the first four digits of the integrated flow rate.

You can also alternately display the first four digits and the last four digits by repeatedly pressing the **Left arrow** key.

For example, if initial reading is **1234** and the 2nd reading is **__56**, the integrated flow rate is **__561234** m^3 .

If the **DISP** key is held down for at least five seconds when switching to the integrated flow rate display from the instantaneous flow rate display, digits past the decimal point for the integrated flow rate are displayed.

Handling Precautions

- When the flow rate exceeds the upper limit of the measurement range, the OVER indicator light, and goes out after the flow rate returns to within the measurement range.
- The integrated flow rate factory setting is 0.
- The integrated flow rate indication returns to 0 after 99999999 is exceeded.
- The flow rate is integrated even if the flow rate is outside of the measurement range. Regard integrated values as a means for grasping the whole quantity of flow.

■ Resetting alarms

When a flow rate alarm detection condition is selected (an item from 1 to 5 in function setup item $\zeta-02$; see page 19), an alarm is set.

To reset the alarm, press the  key.

- ▶ The alarm indicator goes out, and the alarm output relay turns OFF.

Handling Precautions

Alarms are also reset by turning the power OFF.



The alarm recurs after the alarm occurrence wait time when the flow rate exceeds the preset alarm value after the flow monitor is re-energized.

■ Resetting the integrated flow rate

Hold the  key down for at least two seconds while the integrated flow rate is displayed.

- ▶ The integrated value becomes 0.

Handling Precautions

Holding down the  key for two seconds or more while an alarm is occurring merely stops the alarm; it does not reset integrated values. In this case, reset the alarm after the flow rate has returned to within the preset alarm range, and then hold down the  key again for two seconds or more.

■ Displaying the total flow rate

This function displays the total flow rate since the device was installed. Reset cannot be performed by the same reset operation used for integrated flow rate.

(1) Press the key until the integrated flow rate is displayed.

▶ The m³ indicator lights.

(2) Hold the  key for one second or more.

▶ The m³ indicator goes out, and the total flow rate is displayed for 5 seconds.

The total flow, like the integrated flow rate, is displayed in the divided upper four digits and lower four digits, in total 8 digits capable of displaying the maximum m³.

After that, the m³ indicator automatically lights, and the display returns to the integrated flow rate display.

(3) Press the  key again within five seconds while it is displayed.

▶ The first four digit display.

You can also alternately display the first four digits and the last four digits by using the  key repeatedly.

Handling Precautions

- The total flow rate indication returns to 0 after 99999999 is exceeded.
- Integrated flow rate and total flow rate values are held in memory even if the power is turned OFF.
 - On models that display values down to two digits past the decimal point, data is written into memory when the ones digit changes or one hour after the previous writing.
 - On models that display values down to one digit past the decimal point, data is written into memory when the tens digit changes or one hour after the previous writing.
 Integrated values that have not been written to memory are discarded when the power is turned OFF.
- The total flow rate reset setting can be configured to either the enabled or disabled condition using the function setup.
- If the "Reset is performed by key switch" setting has been selected, press the  key for 2 seconds or more while displaying the total flow rate.











The total flow rate and integrated flow rate will be reset and initialized to "0."

Chapter 5. APPLICATION OPERATION



5 - 1 Function Setup

■ Setting operation

Follow the procedure below to set functions such as alarm detection and event output assignments.

- (1) Press the  key to display the instantaneous flow rate.
 - ▶ The m³/h indicator lights.
- (2) Hold the  and  keys down simultaneously for 3 seconds.
 - ▶ Item No. C-01 is displayed on the 7-segment display, and the mode changes to function setup mode.
- (3) Press the  or  key to select the desired setup item, and press the  key.
 - ▶ The current setting blinks on the 7-segment display.
- (4) Press the  or  key to select the desired setting.
- (5) When the desired setting has been selected, press the  key to finalize the setting.
 - ▶ After approx. one second, the item number is redisplayed, and the setting is updated.
- (6) If there are other required setup items, return to step (3) above to repeat the procedure. If there are no other setup items, proceed to step (7).
- (7) Press the  key.
 - ▶ The display changes from the function setup mode to the instantaneous flow rate display.

Handling Precautions

- If you do nothing for one minute after entering the function setup mode, the display automatically returns to the instantaneous flow rate display.
- If you press the  key without pressing the  key after carrying out the operation in step (4), the setting remains at the previous value without being updated.











■ Function setup item list

Item Displayed	Item Description	Settings and Description	Factory Setting	Remarks										
└-01	Key lock	0: Key lock disabled 1: All settings key-locked	0	The key lock can be disabled even while it is enabled.										
└-02	Flow rate alarm detection condition selection	0: Alarm detection is not performed. 1: Only the upper limit alarm is detected. 2: Only lower limit alarm 1 is detected. 3: Upper limit alarm and lower limit alarm 1 are detected. 4: Only lower limit alarm 2 is detected. 5: Upper limit alarm and lower limit alarm 2 are detected.	0	The alarm detection flow rate is set in the parameter setup mode. Lower limit alarm 1: A flow rate less than the lower limit of the measurement range is not judged to be an alarm. Lower limit alarm 2: A flow rate less than the lower limit of the measurement range is judged to be an alarm.										
└-03	Event output 1 (relay) function assignment	0: Not used (OFF at all times) 1: ON when upper limit alarm occurs 2: ON when lower limit alarm occurs 3: ON when upper limit alarm or lower limit alarm occurs 4: ON when integration event occurs	3											
└-04	Event output 2 (open collector) function assignment	0: Not used (OFF at all times) 1: ON when upper limit alarm occurs 2: ON when lower limit alarm occurs 3: ON when upper limit alarm or lower limit alarm occurs 4: ON when integration event occurs 5: Integrated pulse output	5	This item is enabled only for models having the optional event output function.										
└-05	Flow rate alarm reset method selection	0: Only reset by key switch 1: Reset by key switch or automatic reset by normal recovery of flow rate	0											
└-06	Integrated flow rate reset method selection	0: Reset disabled. 1: Reset by key switch only 2: Only automatic reset after the integration reset delay time when the integration event occurs 3: Reset by key switch or automatic reset after the integration reset delay time when the integration event occurs	1											
└-07	Total flow rate reset method selection	0: Reset disabled. 1: Reset by key switch	0	The integrated flow rate is also reset when the total flow rate is reset.										
└-08	Reference temperature selection	0: 0°C 101.325kPa (1 atmosphere) 1: 5°C 101.325kPa (1 atmosphere) 2: 10°C 101.325kPa (1 atmosphere) 3: 15°C 101.325kPa (1 atmosphere) 4: 20°C 101.325kPa (1 atmosphere) 5: 25°C 101.325kPa (1 atmosphere)	0	The reference temperature of the flow rate output can be switched.										
└-09	Pulse rate selection	<table border="1"> <thead> <tr> <th>Decimal point 2digits</th> <th>Decimal point 1digit</th> </tr> </thead> <tbody> <tr> <td>0: 0.001m³/1 pulse</td> <td>0: 0.01m³/1 pulse</td> </tr> <tr> <td>1: 0.01m³/1 pulse</td> <td>1: 0.01m³/1 pulse</td> </tr> <tr> <td>2: 0.1m³/1 pulse</td> <td>2: 0.1m³/1 pulse</td> </tr> <tr> <td>3: 0.1m³/1 pulse</td> <td>3: 1m³/1 pulse</td> </tr> </tbody> </table>	Decimal point 2digits	Decimal point 1digit	0: 0.001m ³ /1 pulse	0: 0.01m ³ /1 pulse	1: 0.01m ³ /1 pulse	1: 0.01m ³ /1 pulse	2: 0.1m ³ /1 pulse	2: 0.1m ³ /1 pulse	3: 0.1m ³ /1 pulse	3: 1m ³ /1 pulse	1	The pulse rate may differ depending on whether measurement is to 2 decimal places or to 1 decimal place.
Decimal point 2digits	Decimal point 1digit													
0: 0.001m ³ /1 pulse	0: 0.01m ³ /1 pulse													
1: 0.01m ³ /1 pulse	1: 0.01m ³ /1 pulse													
2: 0.1m ³ /1 pulse	2: 0.1m ³ /1 pulse													
3: 0.1m ³ /1 pulse	3: 1m ³ /1 pulse													



5 - 2 Parameter Setup

■ Setting operation

Follow the procedure below to set parameters such as the flow rate alarm upper and lower limit values and alarm detection delay times.

- (1) Press the  key to display the instantaneous flow rate.
 - ▶ The m³/h indicator lights.
- (2) Hold the  key down for 3 seconds.
 - ▶ Item [A,HI] is displayed on the 7-segment display, and the mode changes to parameter setup mode.
- (3) Press the  or  key to select the desired setup item, and press the  key.
 - ▶ The current setting blinks on the segment display.
- (4) Press the  or  key to change to the desired value. The digit to be changed can be moved by using the  key.
 - ▶ After approx. one second, the item number is redisplayed, and the setting is updated.
- (5) When the desired setting has been selected, press the  key to finalize the setting.
 - ▶ After approx. one second, the item number is redisplayed, and the setting is updated.
- (6) If there are other required setup items, return to step (3) above to repeat the procedure. If there are no other setup items, proceed to step (7).
- (7) Press the  key.
 - ▶ The display changes from the parameter setup mode to the instantaneous flow rate display.

Handling Precautions

- If there is no input for one minute after the parameter setup mode begins, the display automatically returns to the instantaneous flow rate display.
- If you press the  key without pressing the  key after carrying out the operation in step (4), the setting remains at the previous value without being updated.

■ Parameter setup item list

No.	Item displayed	Item Description	Factory Setting	Setting Range	Remarks
1	<i>R. H</i> (*1)	Instantaneous flow rate upper limit alarm	(Upper limit of measurement range) m ³ /h (normal)	(0 to 400% of measurement upper limit) m ³ /h (normal)	Selection of an alarm detection condition is required in function setup $\zeta - 02$.
2	<i>R. H. HY</i>	Hysteresis for instantaneous flow rate upper limit alarm	(Within 2% of measurement upper limit) m ³ /h (normal)	(0 to 200% of measurement upper limit) m ³ /h (normal)	
3	<i>R. Lo</i> *2	Instantaneous flow rate lower limit alarm	(Lower limit of measure range) m ³ /h (normal)	(0 to 200% of measurement upper limit) m ³ /h (normal)	
4	<i>R. L. HY</i>	Hysteresis for instantaneous flow rate lower limit alarm	(Within 2% of measurement upper limit) m ³ /h(normal)	(0 to 200% of measurement upper limit) m ³ /h (normal)	
5	<i>R. dLY</i>	Delay timing for instantaneous flow rate alarm judgment	60.0s	0.0 to 999.9s	
6	<i>E. SP. L</i>	Integration event setup (lower four digits)	0m ³	0 to 99,999,999m ³	Value set is valid only when selecting integration event output in either $\zeta - 03$ or $\zeta - 04$ of function setup.
7	<i>E. SP. H</i>	Integration event setup (upper four digits)			
8	<i>E. C. dL</i>	Integration reset delay time	10.0s	0.0 to 999.9s	Value set is valid only when selecting automatic reset by integration reset delay in $\zeta - 05$ of function setup.
9	<i>bIAS</i>	Instantaneous flow rate bias (PV bias)	0m ³ /h	(-20 to +20% of measurement upper limit) m ³ /h (normal)	
10	<i>out. H</i>	Instantaneous flow rate output 5V (20mA) scaling	(Upper limit of measurement range) m ³ /h (normal)	(0 to 400% of measurement upper limit) m ³ /h (normal)	
11	<i>out. L</i>	Instantaneous flow rate output 1V (4mA) scaling	0m ³ /h	(0 to 200% of measurement upper limit) m ³ /h (normal)	
12	<i>GRS. C</i>	Gas composition compensation coefficient	1.000	0.100 to 4.000	

Note) "Normal" refers to the volumetric flow rate (m³/h) after converting to 0°C, 101.325kPa (1 atmosphere).

! Handling Precautions

- *1 Be certain to set a flow rate that is less than the display upper limit. Alarm detection will not operate if flow rate is set above the display upper limit.
- *2 If "lower limit alarm1" has been selected in function setup $\zeta - 02$, alarm detection will not operate when the flow rate is less than the lower limit of the measurement range, even if the flow rate is below the lower limit alarm value.

● Instantaneous flow rate upper limit alarm operation

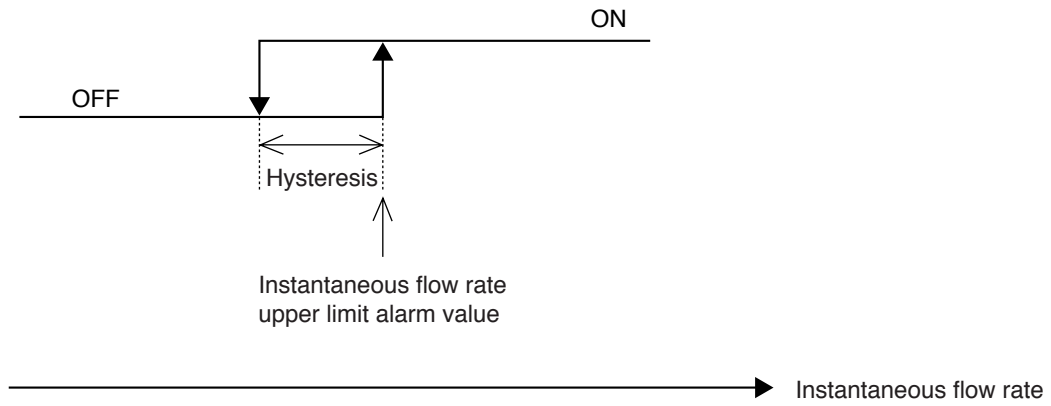

● Instantaneous flow rate lower limit alarm operation

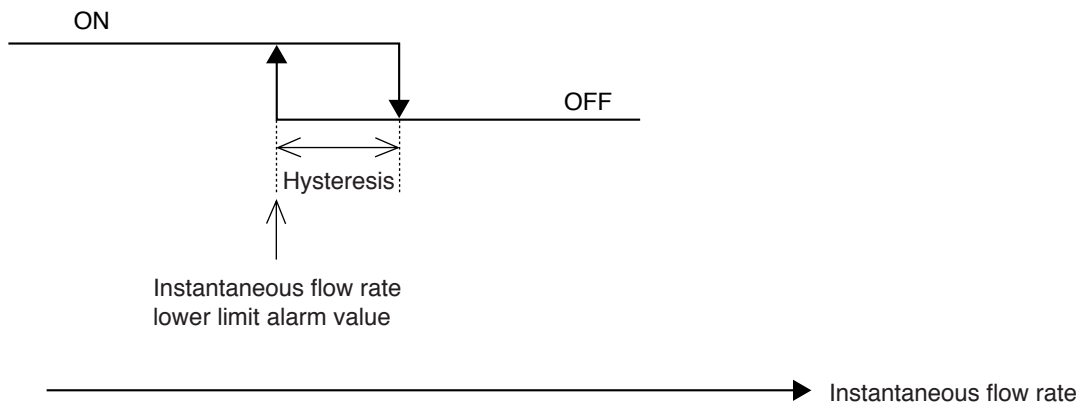

Chapter 6. MAINTENANCE AND TROUBLESHOOTING

■ Remediating trouble

When trouble occurs, refer to the following table:

Problem	Remedy
Nothing is displayed.	<ul style="list-style-type: none"> • Make sure that the power supply voltage and polarity are correct. • Check the connectors connecting the display to the sensor/terminal section for disconnection or faulty contact. • Check the fuse to see if it has blown. If so replace it. For details on how to replace the fuse, see the next item ■ How to replace the fuse.
Err 1 is displayed alternately with the flow rate value.	<ul style="list-style-type: none"> • Check the connectors connecting the display to the sensor/terminal section for disconnection and faulty contact. • If the connectors are free of abnormalities, a probable cause is sensor error. Contact your Yamatake agent as repair by Yamatake is necessary.
Err 2 is displayed alternately with the flow rate value.	<ul style="list-style-type: none"> • The probable cause is an error in the memory, which is individually adjusted for each sensor. Err 2 is displayed, but the operation continues with provisional data in spite of the error. Readjustment by Yamatake is necessary.
The display is other than 0.00 (including a minus display) even though the instantaneous flow rate should be zero.	Check the shut-off valve and piping for any leaks. If the valve and piping are free of leaks, a probable cause is that the device's characteristics have changed. Contact your Yamatake agent as repair by Yamatake is necessary.
A minus is displayed for the instantaneous flow rate.	Make sure that the arrow marked on the flow path matches the direction of gas flow. Correct the directions if it is reversed.
Indicated flow rate varies significantly.	<ul style="list-style-type: none"> • Check that the straight pipe section is long enough. • If the problem seems to be foreign matter stuck to the sensor or the effects of a pulsating flow, contact Yamatake Corporation.

! Handling Precautions

Err 2 (memory error) indicates that the individual adjustment data for the flowmeter's internal sensor has been lost. Accuracy cannot be guaranteed if use of the flowmeter is continued in this state. Ask for repair.

■ How to replace the fuse

⚠ CAUTION

- ⚠ When touching internal parts, touch a grounded metal part to discharge static electricity from the body. Otherwise, static electricity may damage components.
- ⚠ Before replacing the fuse, be sure to turn the power OFF. Failure to do so might cause electric shock.
- ⚠ Be sure to use a fuse having an electrical rating of 250V, and 0.5A for replacement on the 24Vdc power supply type, and a fuse having an electrical rating of 250V, and 2.0A for replacement on the AC power supply type. Use of a non-rated fuse prevents the safety circuit from functioning properly.

● Needed items

Phillips screwdriver

Fuse: 24Vdc power supply type:

Made by Cooper Bussmann U K Ltd: Model No. S504 500mA (250V, 0.5A)

Made by Littelfuse: Model No. 218.500 (250V, 0.5A)

Standard	IEC127
Fuse blowout speed	Time-lag
Rated voltage	250V
Rated current	0.5A

AC power supply type:

Made by Toyo Fuse: Model No. MF51NR250V2.0A (250V, 2.0A)

● Replacement procedure

- (1) Loosen the four screws on the operation panel/display.
- (2) Gently lift up the operation panel/display.
- (3) Remove the fuse cover.
For details, see Chapter 2. NAMES AND FUNCTIONS OF PARTS.
- (4) Remove the fuse.
- (5) Attach the new fuse.
- (6) Attach the fuse cover.
- (7) Attach the operation panel/display in its original position on the sensor/terminal section.

⚠ Handling Precautions

When a fuse blows, check for abnormal power voltage, miswiring, or other causes of the fuse having blown.

Replacement of parts is precision work. Take sufficient care not to lose or damage removed components.

Chapter 7. SPECIFICATIONS

■ CMG Series specifications

Item		Specifications
Applicable gas		Natural gas (13A)(*1), air (according to model No.), propane (*2), butane (*3)
Material		Flow path section: aluminum alloy (Rc thread), SCS13 (flange) Display section: PBT (GF 30%)
Instantaneous flow rate display accuracy	Natural gas (13A), air	Measurement range Accuracy: $\pm 4\%RD \pm 1$ digit (10 to 40°C) $\pm 6\%RD \pm 1$ digit (-10 to +60°C)
	Propane, butane	Measurement range Accuracy: $\pm 6\%RD \pm 1$ digit (10 to 40°C)
Pressure range		Low-pressure model: less than 100kPa Medium-pressure model: less than 1.0MPa
Pressure resistance		Low-pressure model: 150kPa. Medium-pressure model: 1.5MPa
Allowable ambient temperature, gas temperature		-10 to +60°C (no freezing allowed)
Storage ambient temperature		-20 to +70°C (no freezing allowed)
Allowable ambient humidity		40°C, 90%RH or less (no condensation allowed)
Rated voltage		24Vdc, 100Vac, 200Vac
Allowable voltage		24Vdc: $\pm 10\%$ of rated voltage. 100Vac, 200Vac: 85% to 110%
Power consumption		24Vdc: 5.5W or less. AC model: 2W or less
Flow rate display method		Flow quantity adjusted for 0°C and 101.325kPa (1 atmospheric pressure)
Instantaneous flow rate repeatability		$\pm 1\%RD \pm 1$ digit (20°C)
Response speed		Sampling cycle 100ms, 0→100% step response 1.6s
Instantaneous flow rate output	1 to 5Vdc voltage output	Output range: 0 to 400% of measurement range upper limit (scalable) Accuracy: $\pm 0.5\%FS$ Wiring distance: within 10m External load resistance: 10kΩ or more
	4 to 20mA current output	Output range: 0 to 400% of measurement range upper limit (scalable) Accuracy: $\pm 0.5\%FS$ Load resistance: 300Ω max.
Event output 1		1a contact (closes at event generation) Contact rating: 250Vac, 30Vdc, 5A (resistance load) Mechanical life: 20 million cycles Electrical life: 70,000 cycles
Event output 2 (4 to 20mA output model only)		Output configuration: NPN open collector output Output rated: 30V 50mA max. When integrated pulse output is selected: Pulse width: 100ms $\pm 20\%$ For measurement to 2 digits after the decimal point range: Select either a 0.001m ³ /pulse, 0.01m ³ /pulse or 0.1m ³ /pulse For measurement to 1 digit after the decimal point range: Select either a 0.01m ³ /pulse, 0.1m ³ /pulse or 1m ³ /pulse
Conduit size		G 1/2, 2 pieces
Vibration resistance		5m/s ² or less, 10 to 60Hz, for 2 hours each in X, Y and Z directions
Shock resistance		500m/s ² or less, 3 times each in X, Y and Z directions
Voltage resistance	24Vdc power supply model	Between terminal 5 and flow path, and between terminal 6 and flow path: 1500Vac for 1min or 1800Vac for 1s
	AC power supply model	Between terminals 1/2 and flow path: 1500Vac for 1min or 1800Vac for 1s Between terminals 3/4 and flow path: 1500Vac for 1min or 1800Vac for 1s
Insulation resistance		Between each terminal and flow path metal parts: min. 50MΩ (500Vmegger dc)
Protection		IP54 (JIS C 0920) splash-proof and dustproof structure
Applicable standards		EN61326-1:1997 A1:1998, EN61010-1:2001
Over-voltage category		Category II
Pollution degree		Pollution degree 2
Altitude		2000m or less

*1: Natural gas composition: LNG, methane 88%, 46MJ/m³ *2: Propane gas composition: propane 98%, (class B)
*3: Butane gas composition: butane 75%, propane 25%

■ Individual CMG model specifications

Item		Specifications						
Model No.		CMG15	CMG25		CMG40		CMG50	
Piping size	Thread connection	Rc 1/2"	Rc 1"		Rc 1 1/2"		Rc 2"	
	Flange connection	-	-		40A JIS 10K RF		50A JIS 10K RF	
Flow rate range *1 m ³ /h (normal) *2	Natural gas(13A)	0.50 to 4.00	1.00 to 10.00	3.0 to 30.0	8.0 to 80.0	15.0 to 150.0	8.0 to 80.0	15.0 to 150.0
	Air	0.00 to 7.00	0.00 to 16.00	0.0 to 35.0	0.0 to 100.0	0.0 to 170.0	0.0 to 100.0	0.0 to 170.0
Measurement range (top) Display range (bottom)	Propane *3	0.20 to 2.00	0.40 to 4.00	1.00 to 10.0	0 2.5 to 25.0	5.0 to 50.0	2.5 to 25.0	5.0 to 50.0
	Butane	0.10 to 1.00	0.30 to 3.00	0.80 to 8.00	2.0 to 20.0	4.0 to 40.0	2.0 to 20.0	4.0 to 40.0
Straight pipe connection length for pipe with 90° bent	Upstream side *4	Not required	Not required	15cm or more	10cm or more	40cm or more	10cm or more	40cm or more
	Downstream side	Not required	Not required	10cm or more	5cm or more	20cm or more	5cm or more	20cm or more
Pressure loss upper limit value for air	Thread connection	140Pa	215Pa	210Pa	500Pa	1300Pa	285Pa	550Pa
	Flange connection	-	-	-	390Pa	840Pa	250Pa	430Pa
Mass	Rc thread	Approx. 850g	Approx. 800g		Approx. 2100g		Approx. 2000g	
	Flange	-	-		Approx. 9 kg		Approx. 10 kg	

- *1: The number of digits displayed after the decimal point for m³/h is the same as that shown in the table.
- *2: "Normal" refers to the volumetric flow rate (m³/h) after converting to 0°C, 101.325 kPa (1 atmosphere).
- *3: The measurement range is the flow rate range in which instantaneous flow rate display accuracy is stipulated.
- *4: Straight pipe longer than the length specified above may be required depending on the pipe shape or other devices mounted on the piping. The length of downstream straight pipe section is a standard value.

Straight pipe section (rough guidelines)

- Same diameter pipe (diameters A and B are the same)

Upstream elbow

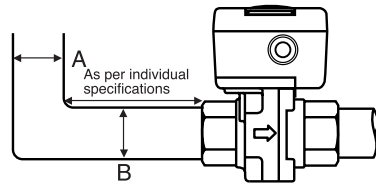

Downstream elbow

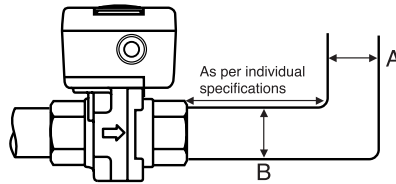

- Different diameter pipe (diameter A is different from diameter B) D: inner dia. connecting pipe

Upstream side enlarged (Different diameter socket)

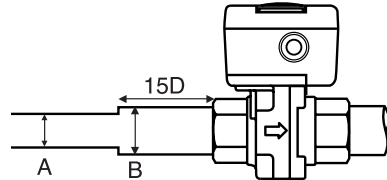

Downstream side reduced (Different diameter socket)

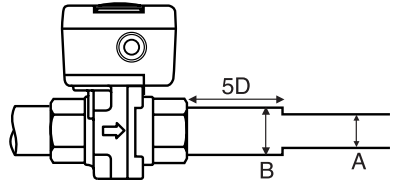

Upstream side reduced (Different diameter socket)

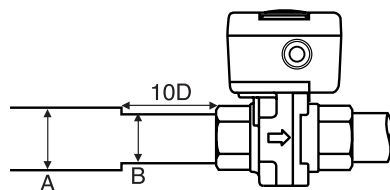

Downstream side enlarged (Different diameter socket)

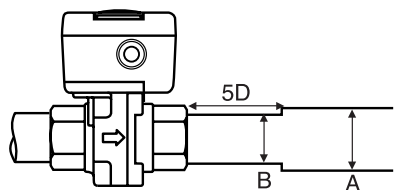

Upstream side enlarged
(Enlarging pipe is used)

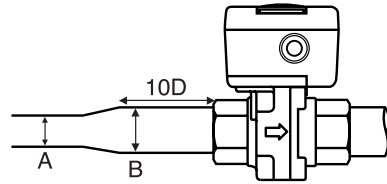

Downstream side reduced
(Reducing pipe is used)

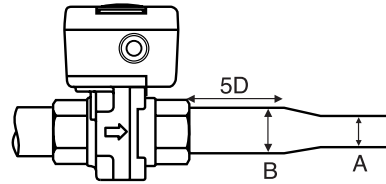

Upstream side reduced
(Reducing pipe is used)

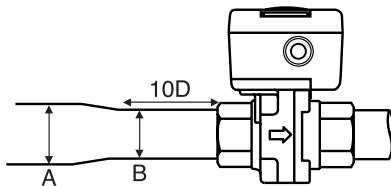

Downstream side enlarged
(Enlarging pipe is used)

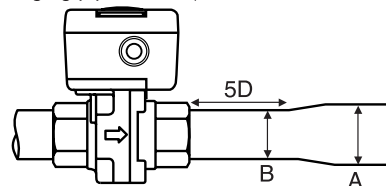

• Valves (fully open) D: inner dia. of connecting pipe

Upstream

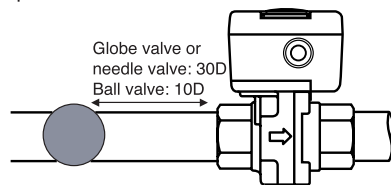

Downstream

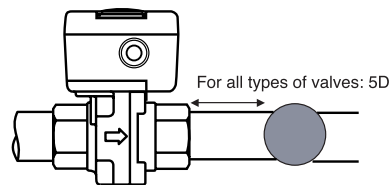

! Handling Precautions

- In case of globe, butterfly or needle valves, which cause disturbance or fluctuations to the flow, a straight pipe length of more than 30D is required. Install a flow-adjusting valve as far downstream of the CMG as possible.

Contact Yamatake Corporation for valves other than the above.

● When selecting a medium pressure model for air and natural gas (13A)

On a medium pressure model for air and natural gas (13A), only the following combinations can be selected:

Pipe size	Pipe shape	Gas type	Flow rate range	Output	Power supply
25	Rc thread	Air	30m ³ /h	4 to 20mA + event output	100/200Vac
40, 50			80, 150m ³ /h		
40, 50	JIS 10K flange	Air Natural gas (13A)	80, 150m ³ /h	4 to 20mA + event output	24Vdc 100/200Vac

■ Pressure loss

- For Rc thread, the data shows pressure loss for air.

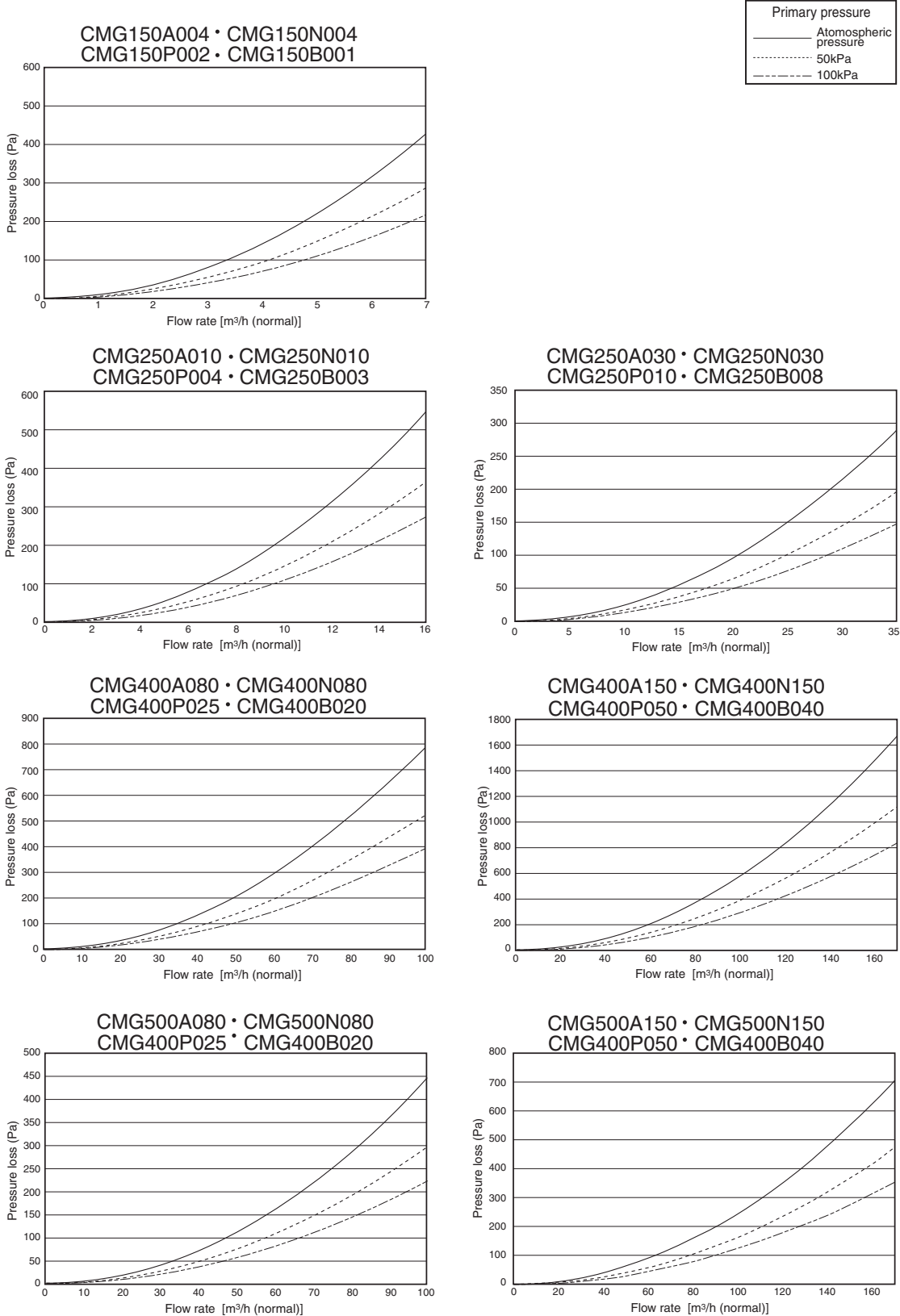

- For air and city gas (13A) models with JIS10K flange, the data shows pressure loss for air.

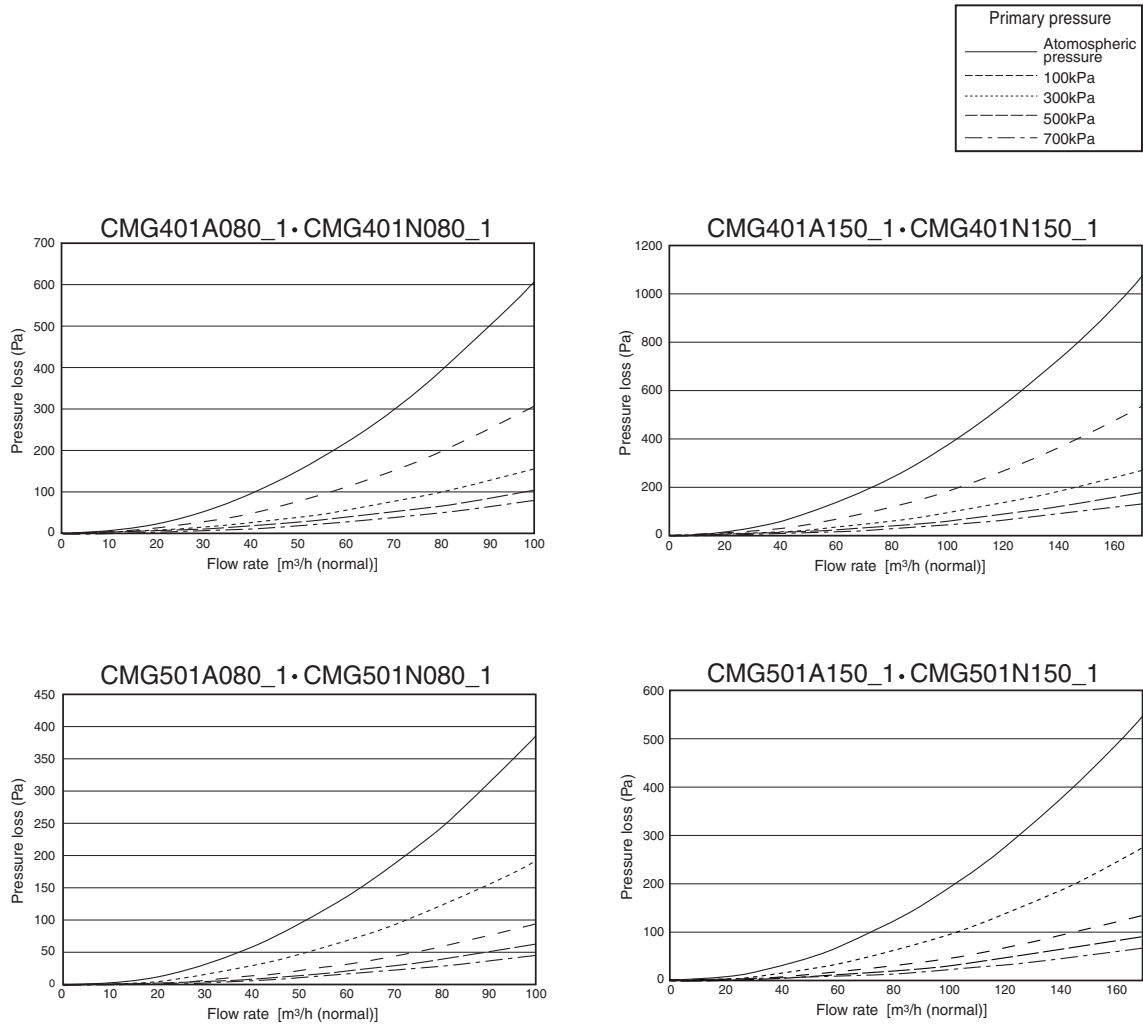

The values for the gases other than air can be obtained by multiplying the specific gravities shown in the table below.

Applicable gas	The specific gravity
City gas 13A (methane 88%)	0.64
Propane (class B)	1.57
Butane (butane 75%, propane 25%)	1.93

External dimensions

Unit: mm

● CMG150/250

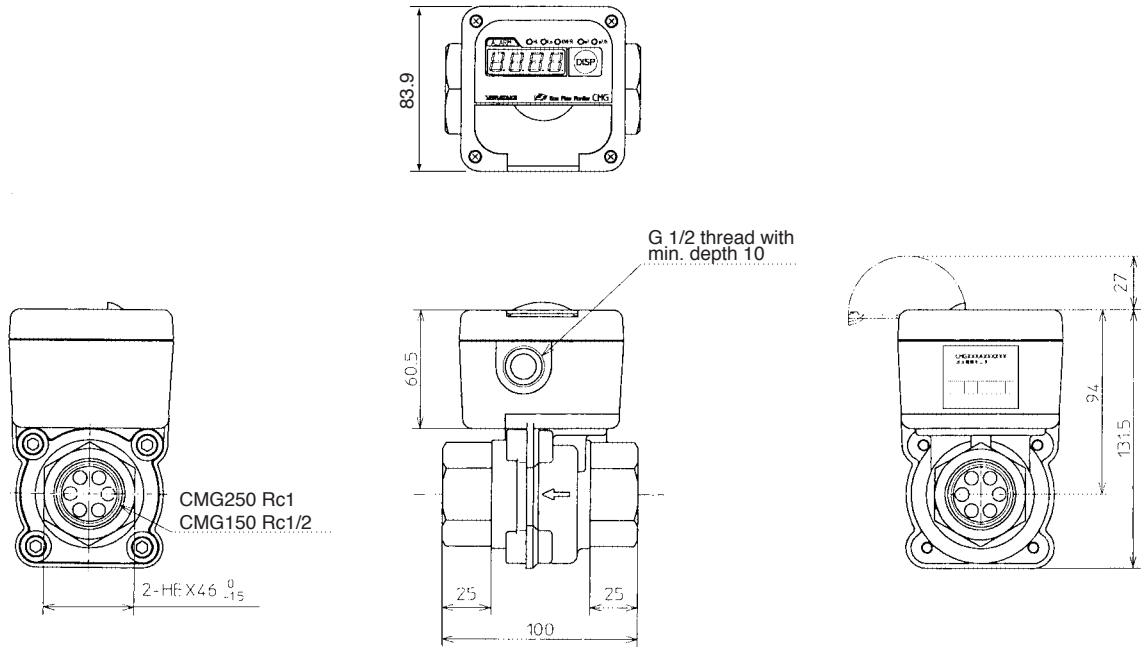

● CMG400/500

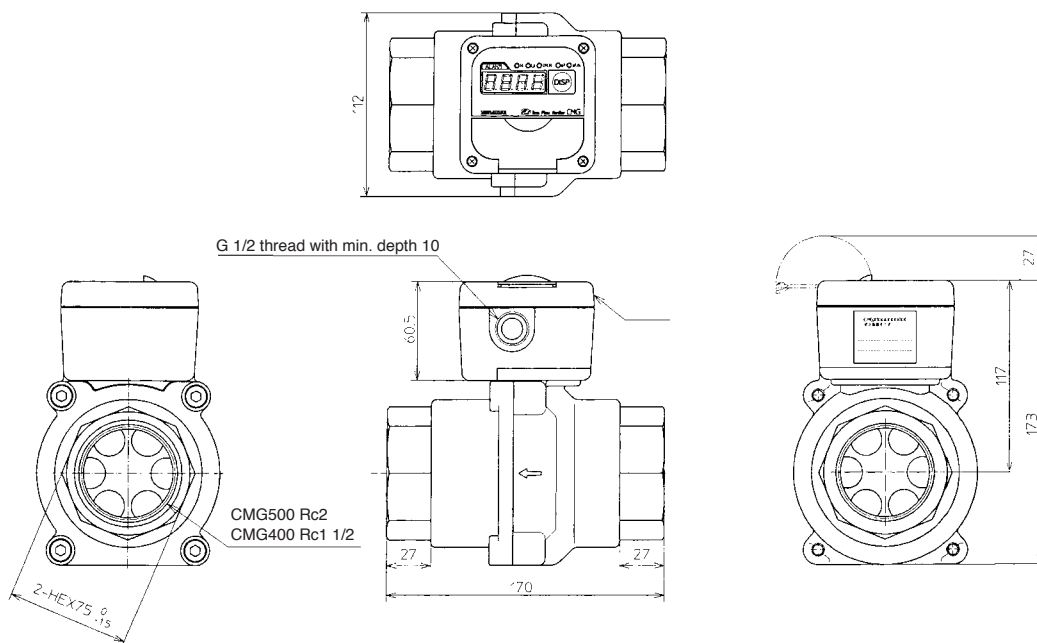

● CMG401

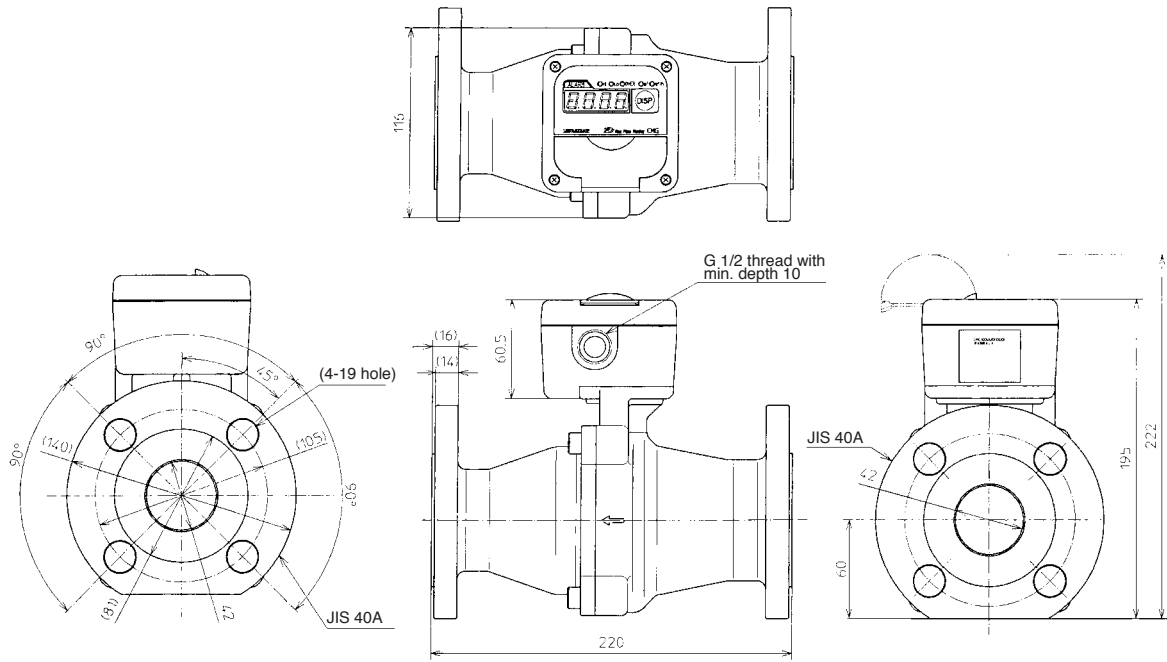

● CMG501

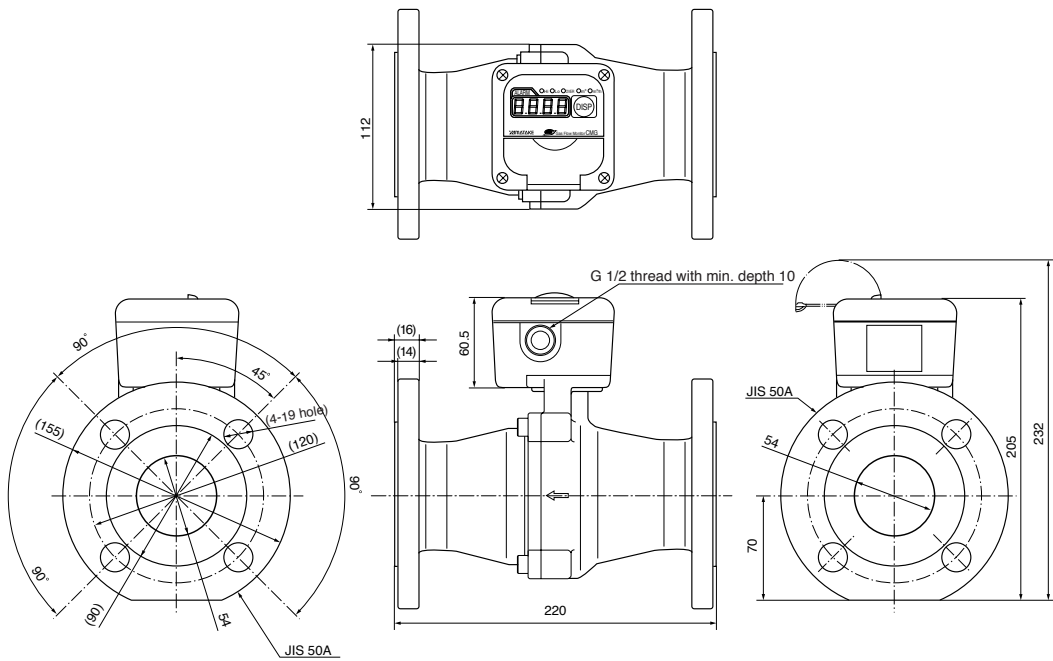

Revision History

Printed Date	Manual Number	Edition	Revised pages	Description
July 2001	CP-SP-1113E	1st Edition		
Apr. 2003		2nd Edition	ii iii iv, v 2 3 11 23 25 26 27, 28	Description changed on the 2nd item in WARNING. Item added in CAUTION. Old iii, iv pages. *3 added to the medium pressure model. *3 description added. Symbol table added. Fuse model No. for 24Vdc type changed. *3 description changed. Item of "When selecting a medium pressure model for air and city gas (13A)" added. Old pages 26 and 27.
Dec. 2003		3rd Edition	2, 3 11 18 20 24 25 26, 27	*3 changed. Symbol of direct current changed. The power supply symbol changed to the one of a model complying with CE. C-09 the description on "setup item and description " and "remarks" changed. Setup range of No.1, 10 : 0 to 200% changed to 0 to 400%. Setup range of No.2 to 4, 11 : 0 to 100% changed to 0 to 200%. Setup range of No.9 : -10 to +10% changed to -20 to +20%. Setup range of No.12 : 0.600 to 1.400 changed to 0.100 to 4.000. Output range of instantaneous flowrate output : 200% changed to 400%. Decimal point 2 digits of event output 2 : 0.1m ³ /pulse added. Decimal point 1 digit 1m ³ /pulse added. Applicable standards added. "Measurement range *2", "display range" changed to "Flowrate range m ³ /h(normal) *1", "measurement range(upper) *2", "display range (lower)". 13A(N) changed to City gas (13A). Moved from 26 page. Old 27, 28 page.
Apr. 2004		4th Edition	1 7 16 18 20 25 26 27, 28	Description added to the 4th item in Features. Description added in CAUTION. Description added to the 2nd line from the top. Description added to the 3rd item in Handling Precautions, also the 4th item added. Description on C-04 changed in Remarks column. No.9 and 11 factory setting values changed from 0m ³ to 0m ³ /h. Specifications table changed on the item of "Upstream straight pipe connection". Item of " Straight pipe section (guide line)" added. Item of ●When selecting a medium pressure model for..... moved from page 25. Old 26 and 27 page.
Sep. 2004		5th Edition	25	*3 : Description added.

Printed Date	Manual Number	Edition	Revised pages	Description
Dec. 2005		6th Edition	25, 26	D: Connection piping size added.
May 2005		7th Edition	All page 4 5 7 8-10 13 14 16 17 18, 20 24 25 26, 27	"Flowrate" to "Flow rate" changed. "Zero adjustment" removed from the description of RESET key and ENT key. Description clarified. Item of ■Pipes added. Pages changed from 7–28. One item added to Handling Precautions. Two sections of Handling Precautions combined. Description clarified on ■Resetting alarms. Description clarified on ■Displaying the total flowrate. Description clarified on ■Setting operation. Description clarified on replacing the fuse in CAUTION. Order of specifications changed. Event output 1: Electrical life changed from 100,000 to 70,000 cycles. Event output 2: "Load" changed to "Output rated." Straight pipe section: Illustration changed.
Oct. 2005		8th Edition	All page 4 12	"City gas" to "Natural gas" changed. Description of operation panel changed. Note added to figure of ●Wiring 24Vdc power supply model.
Dec. 2005		9th Edition	7 12 13	Model No. of mist separator added. Description of terminal 5,6 added. Note added to figure of ●Wiring the AC power supply model. Terminal 7 "EVENT" to "EVENT2" changed. Description of terminal 3,4 added.
Apr. 2006		10th Edition	ii iii 5 6 12, 13 23 25 26 28, 29 30, 31	Item added in WARNING. Description changed on the 3rd item in CAUTION. Item added in CAUTION. The common mode voltage between output and ground are changed. Item of 11. and 12. added. Description on the Terminal: EVENT2 added. Item added on the table. Items of ■Common specifications added. Note *1 added. ■Pressure loss added. Old 28, 29 page
July 2006		11th Edition	29	Description of pressure loss for the gas other than air added.
June 2007		12th Edition	ii iv, 25 iv, 26 1 5 6	Description changed on the 3rd item and 5th item in CAUTION. ■Common specifications changed to ■CMG Series specifications. ■Individual specifications changed to ■Individual CMG model specifications. Description changed in ■Introduction. Description changed on 3rd item in ■Features. Description changed on 8th item in Handling Precautions. Item of ●installation site added.

azbil

Yamatake Corporation
Advanced Automation Company

1-12-2 Kawana, Fujisawa
Kanagawa 251-8522 Japan

URL: <http://www.azbil.com>

Printed on recycled paper. (07)

Specifications are subject to change without notice.

Printed in Japan.
1st Edition: Issued in July 2001 (W)
12th Edition: Issued in June 2007 (A)