

SP.NO.

Yamatake Corporation

製品仕様書 SPECIFICATIONS

1. Scope

This document covers specifications for a Mass Flow Meter used for household fuel cells.

This device is a Mass Flow Meter that uses the Yamatake μ F (Micro Flow) thermal mass flow sensor as its sensing element.

Integrating the μ F sensor with advanced channel design technology has achieved high accuracy and high rangeability.

2. Model Selection Table

Basic No.	Meas. Range	Type	Mat'l	Piping connection	Gas type	Power	Option 1	Option 2	Design code	Description
MRG	0002									0 to 2 L/min (NTP)
		G								For fuel gases
			A							Die-cast aluminum
				Q						Quick Fastener (O-ring size = P10)
					P					Propane 100%-composition
						0				5 Vdc
							0			Standard specifications
								0		Standard specifications
									1	Product version (Improved)

Note: Cable, electric connector, fitting or piping connection coupler is not attached.

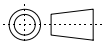
作成 DR. K.Niikawa		尺度 SCALE ~	記入のない公差 TOL.UNLESS NOTED ~
---------------------	--------------------------------------------------------------------------------------	---------------	-------------------------------

検図 CHK. H.Inagaki	形番 MODEL	MRG0002GAQP0001
----------------------	-------------	-----------------

認可 APPD K.Harada	名称 NAME	Mass Flow Meter used for household fuel cells
---------------------	------------	--------------------------------------------------

頁 改番	改番 REV.	来歴 RECORD	日付 DATE	担当 BY	認可 APPD.	日付 DATE 8th Sep. 2010	図番 NO.	AD16231E	改番 REV 00	1 / 11
---------	------------	--------------	------------	----------	-------------	-----------------------------	-----------	----------	--------------	--------

SP.NO.

Yamatake Corporation

**製品仕様書
SPECIFICATIONS**

3. Specifications

3.1 General specifications

Operating pressure 0 to 50kPa (gauge)
 Pressure resistance (positive pressure) 100kPa (gauge)
 Pressure resistance (negative pressure) -50kPa (gauge)
 Compatible gases Propane 100%-composition

Notes1:

Do not allow dust or mist 1 μm or more in diameter to enter the MRG.

Measurement flow range 0 to 2L/min (NTP)
 Minimum flow rate 0.05L/min (NTP)
 Guaranteed accuracy range 0.1 to 2.0L/min (NTP)
 Accuracy ± 3.5 % FS
 Total accuracy including temperature and pressure characteristics,
 in the -10 to +60 °C operating temperature range and 0 to 50 kPa (gauge)
 operating pressure range
 Repeatability ± 1 % FS
 Repeatability error at the same temperature and pressure with continuous
 power on .
 Piping connection method Quick fastener
 Applicable O-ring size : P10 (defined by JIS B2401)
 Protective structure IP40
 Material Compliant with EU RoHS Directive 2002/95/EC
 Allowable maximum flow rate Under twice flow rate of the measurement flow range
 Leakage tightness 20mL/h max., 100kPa inlet pressure applied condition
 (EN 161-compliant)
 Pressure loss 0.2kPa at 5.0L/min. (NTP) (with air flow)

NTP : Stands for normal temperature and pressure, and indicates
 the volume converted to conditions of 0 °C and 101.325kPa (abs)
 % FS : Percentage of full-scale output

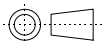
作成 DR. K.Nirikawa		尺度 SCALE ~	記入のない公差 TOL.UNLESS NOTED ~
----------------------	--------------------------------------------------------------------------------------	---------------	-------------------------------

検図 CHK. H.Inagaki	形番 MODEL	MRG0002GAQP0001
----------------------	-------------	-----------------

認可 APPD K.Harada	名称 NAME	Mass Flow Meter used for household fuel cells
---------------------	------------	--------------------------------------------------

頁 改番	改番 REV.	来歴 RECORD	日付 DATE	担当 BY	認可 APPD.	日付 DATE 8th Sep. 2010	図番 NO.	AD16231E	改番 REV 00	2 / 11
---------	------------	--------------	------------	----------	-------------	-----------------------------	-----------	----------	--------------	--------

SP.NO.

3.2 Electrical specifications

Supply power 5Vdc ± 10 %
 Ripple voltage 2.5 % max.
 Output signal 1 to 5Vdc
 Output voltage at flow 0L/min : 1.0 +/- 0.14Vdc
 Maximum output voltage : 5.4Vdc max.
 Required external load resistance 500kΩ min.

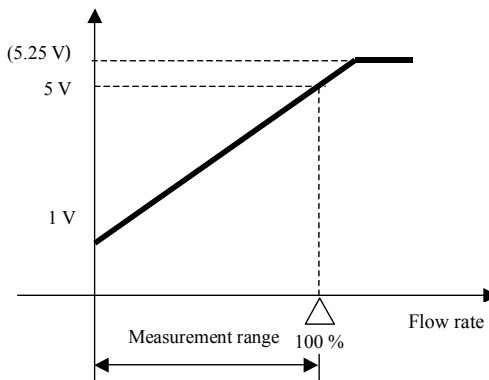

Note1:

Because the MRG's electric circuit has been not stabilized immediately after the power has been turned on, there may be an unexpected temporary voltage output.

For safe operation, wait for about 3 seconds after power-on before use.

Note2:

Either of output voltage at flow 0L/min and maximum output voltage is just electric specification, not including measurement accuracy.

Note3:

When external load resistance is under 500kΩ, output signal has the possibility not to reach to the stated voltage value.
 (The output signal does not correspond to the actual flow rate)

Note4:

MRG can not measure the reverse flow.
 Concerning of the behavior at reverse flow, refer "5. Handling Precautions 18) Behavior during reverse flow" on page 8/11.

Signal resolution Approx. 4mV
 Response time Time until the output reaches ±5 % of the final output during step input:
 2s max.
 Power consumption 0.1W max.
 Insulation resistance 20MΩ min. at 500Vdc
 (between all external connector terminals and the flow channel body)
 Dielectric strength Leakage current is 1mA max. at 500Vac for 1 minute
 (between all external connector terminals and the flow channel body).
 Note:
 MRG cannot withstand 600Vac for 1 second, so do not use those conditions as an alternative test.
 Warm-up time 5min min.
 Accuracy is determined 5 min or more after the power has been turned on.

作成 DR. K.Nikawa		尺度 SCALE ~	記入のない公差 TOL.UNLESS NOTED ~
--------------------	--	---------------	-------------------------------

検図 CHK. H.Inagaki	形番 MODEL	MRG0002GAQP0001
----------------------	-------------	-----------------

認可 APPD K.Harada	名称 NAME	Mass Flow Meter used for household fuel cells
---------------------	------------	--------------------------------------------------

日付 DATE 8th Sep. 2010	図番 NO.	AD16231E	改番 REV. 00	3 / 11
-----------------------------	-----------	----------	---------------	--------

頁	改番	改番 REV.	来歴 RECORD	日付 DATE	担当 BY	認可 APPD.
---	----	---------	--------------	------------	----------	-------------

SP.NO.

Yamatake Corporation

製品仕様書
SPECIFICATIONS

4. Wiring

Connector No.	Meaning	Description
4	Vcc: Power supply	Rating 5 V \pm 10 %
3	OUT: Flow output	1 to 5 V output (required external load resistance: 500 k Ω min.)
2		Not used
1	GND	

Notes1:

- 1) There is no isolation between any inputs and outputs.
- 2) Do not use connector pin 2, which is a communication terminal for device adjustment during manufacturing.

Note2:

Connectors between the MRG and other device are shown below.

Connector at MRG side: XA connector, model No. BM04B-XASS-TF
(2.5 mm pitch/with lock), made by J.S.T. Mfg. Co., Ltd.Other end of connection: XA connectors, model Nos. XARP-04V (retainer mountable type)
or XAP-04V-1 (standard type), made by J.S.T. Mfg. Co., Ltd.

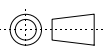
作成 DR. K.Niikawa		尺度 SCALE ~	記入のない公差 TOL.UNLESS NOTED ~
検図 CHK. H.Inagaki	形番 MODEL	MRG0002GAQP0001	
認可 APPD K.Harada	名称 NAME	Mass Flow Meter used for household fuel cells	
日付 DATE 8th Sep. 2010	図番 NO.	AD16231E	改番 REV 00
頁 改番	改番 REV.	来歴 RECORD	日付 DATE
担当 BY	認可 APPD.		5 / 11

SP.NO.

Yamatake Corporation

製品仕様書
SPECIFICATIONS

5. Handling Precautions

- 1) The MRG is a precision instrument. Do not drop it or subject it to shock. Doing so might damage the device. Excessive voltage or current, or incorrect wiring, can also damage the device.
- 2) Check that there are no safety problems before use.
- 3) The MRG0002GA is designed exclusively for Propane. Do not use it for a fluid other than Propane. Doing so could cause a serious accident.
Never allow a gas that is within explosive limits to pass through this device. Doing so might result in an explosion. To ensure that gas is not within explosive limits, design the piping layout and instrumentation so that air cannot enter the gas.
- 4) Prevent foreign matter from entering the MRG. If rust, water droplets, oil mist, or dust in the pipes enters the device, measurement error or damage to the device might occur.
If there is a possibility of foreign matter entering the device, install a filter, strainer or mist trap capable of eliminating foreign matter 1 μ m or greater in diameter on upstream side of the device. Be sure to maintain and replace the filter at regular intervals. Notice, too, that foreign matter might enter the device from the outlet side due to reverse flow. If reverse flow is a possibility, provide a reverse flow protection unit, filter or the like on the outlet side. Recommended filter characteristics are shown below.

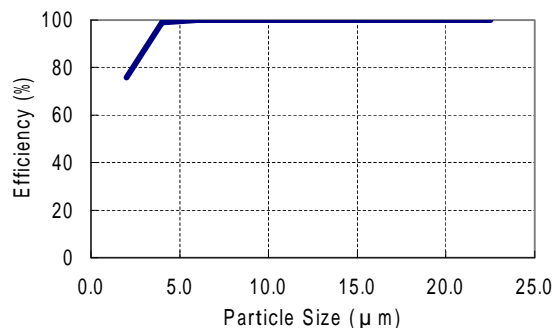

Particle Size (μ m)	Efficiency (%)
2	75.91
4	99.07
6	99.92
8.5	99.93
12.5	>99.99
17.5	>99.99
22.5	>99.99

This evaluation test is conducted with water.

If the fluid is a gas, it is best to convert the particle size to 1/10. (e.g.: Water=12.5 μ m to Gas=1.25 μ m)

- 5) Be sure to use within the flow-rate range stipulated in the product specifications.
Design the piping layout and instrumentation carefully to prevent excessive flow. If the flow rate exceeds the upper limit, the output value may indicate a considerably lower flow rate than the actual one.
- 6) Do not use the MRG out of the operating pressure range, or subject it to pressure above its pressure resistance. Doing so might damage it.
- 7) If damage and injury could result from the abnormal functioning of the MRG, take appropriate redundancy design in the system. Since the output voltage may fluctuate in the event of a device failure, it may indicate a flow rate that varies considerably from the actual flow rate.
- 8) Do not peel seals off until immediately before piping connecting. If a seal is removed prematurely, foreign matter can enter the MRG and cause faulty operation.
- 9) Take care not to damage sealing surfaces during installation. Damage may cause leaks.

作成 DR. K.Niikawa		尺度 SCALE ~	記入のない公差 TOL.UNLESS NOTED ~
---------------------	--	---------------	-------------------------------

検図 CHK. H.Inagaki	形番 MODEL	MRG0002GAQP0001
----------------------	-------------	-----------------

認可 APPD K.Harada	名称 NAME	Mass Flow Meter used for household fuel cells
---------------------	------------	--------------------------------------------------

頁	改番	改番 REV.	来歴 RECORD	日付 DATE	担当 BY	認可 APPD.	日付 DATE 8th Sep. 2010	図番 NO.	AD16231E	改番 REV. 00	6 / 11
---	----	---------	--------------	------------	----------	-------------	-----------------------------	-----------	----------	---------------	--------

SP.NO.

Yamatake Corporation

製品仕様書
SPECIFICATIONS

10) Installation site

Avoid mounting the MRG in locations where:

- Ambient temperature falls below -10 °C or rises above +60 °C.
- Ambient humidity exceeds 95 % RH.
- Device is exposed to sudden temperature fluctuations and dew condensation.
- Device is exposed in corrosive or flammable gas atmospheres.
- Device is exposed to large amounts of dust, salt, iron powder or other conductive substances, water droplets, oil mist, or organic solvents.
- Device receives direct vibration or shock.
- Device is exposed to direct sunlight.
- Device is exposed to water or rain.
- Device is splashed by liquid (e.g. oil, chemicals).
- Device is exposed to strong electric or magnetic fields.

11) Mount the MRG horizontally. However, do not mount with the electric connector facing down. Doing so might cause measurement error or device failure.

Because the MRG is neither waterproof nor drip-proof, take countermeasures if there is possibility of water drops falling onto the device. Under circumstances prone to cause condensation, pay attention to cabling to prevent water drops from entering the device by running along the cable.

12) Wiring

During wiring, do not apply excessive force to the connector, or it might be damaged. Pay attention to the cable length and layout to be sure that the connector cable will not be continuously pulled. Check that the wiring is correct before turning the power on. Wiring error could cause damage or faulty operation.

The I/O signal wires should be well away from power lines and power cords. Also, do not run these kinds of wires through the same conduit or duct.

13) Do not remove the case and disassemble the components inside. Doing so could cause damage.

14) Pay attention to pipe layout so that it will not continuously apply excessive force on the MRG.

A damaged flowmeter could cause a serious accident like a fluid leak.

15) Mount the MRG securely using the mounting screws. Tighten the screws to the specified torque.

If they are tightened with excessive torque, the attachment section could be damaged.

MRG has asymmetrical mounting screw positions in order to prevent reverse mounting.

To prevent a wrong installation, the MRG0002GA has distinctive mounting dimensions from other MRG models. To prevent a wrong installation (e.g. reverse mounting or installation of wrong flowmeter), do not create any new hole for securing the MRG other than the screw holes in the attachment section.

For details of the screw torque and dimensions, refer to External Dimensions on page 10/11.

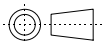
作成 DR. K.Nirikawa		尺度 SCALE ~	記入のない公差 TOL.UNLESS NOTED ~
検図 CHK. H.Inagaki	形番 MODEL	MRG0002GAQP0001	
認可 APPD K.Harada	名称 NAME	Mass Flow Meter used for household fuel cells	
日付 DATE 8th Sep. 2010	図番 NO.	AD16231E	改番 REV 00
頁 改番	改番 REV.	来歴 RECORD	日付 DATE
			担当 BY
			認可 APPD.
			7/11

SP. NO.

Yamatake Corporation

製品仕様書
SPECIFICATIONS

- 16) Do not allow fingers or foreign matter to enter the flow path when handling the MRG.
Doing so could cause impaired operation or faulty operation due to damaged parts in the flow path.
Also, do not blow with an air gun to clean the flow path. Doing so could damage the sensor and make flow measurement impossible.
- 17) Behavior when the flow rate exceeds the measurement range.
If the flow rate exceeds the high limit of measurement, the correct value may not be output.
Be sure to use the MRG within the measurement range specified in the specifications.
Even if the actual flow rate exceeds the measurement range, the output will not increase beyond 5.25V.
In addition, if the flow rate exceeds 4 times (400%) the measurement range, the output may decrease and a normal voltage could be output as if the flow rate were within the measurement range. Furthermore, if the flow rate rapidly exceeds 4 times the measurement range, the output may suddenly show the value within the measurement range, without the prior output of 5.25V.
- 18) Behavior during reverse flow
Since MRG does not have flow rectification structure inside, if there is a reverse flow, the output may be 1V or more. And MRG is not designed for reverse flow measurement, so that take countermeasures such as installation of check valve to prevent reverse flow.

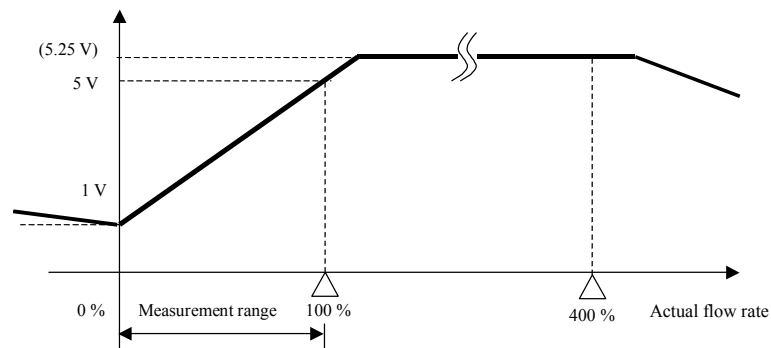

- 19) Since the MRG is not resistant to power surge cause by lightning, take external countermeasures against power surge.
- 20) When disposing of the device, observe local regulations.
- 21) However the MRG is designed to prevent the influence of the disorder caused by piping layout, measurement error may become large under the conditions noted below. Therefore, do an operational check under the actual installation conditions. If any effect is found, add a straight pipe section around 5 times longer than the internal pipe diameter on the upstream or downstream side of the MRG.
- * In the case that there is a step or a difference in inner diameter of the piping layout.
 - * In the case that there is an uneven flow due to sharply curved piping or a valve installed before or after the MRG.

Since a measurement error may become large if there is a pulsating flow caused by a pressure booster pump or blower, use a buffer tank or the like to prevent a pulsating flow.

作成 DR. K.Nirikawa		尺度 SCALE ~	記入のない公差 TOL.UNLESS NOTED ~
検図 CHK. H.Inagaki	形番 MODEL	MRG0002GAQP0001	
認可 APPD K.Harada	名称 NAME	Mass Flow Meter used for household fuel cells	
日付 DATE 8th Sep. 2010	図番 NO.	AD16231E	改番 REV 00 / 8 / 11

頁 改番

改番
REV.来歴
RECORD日付
DATE担当
BY認可
APPD.日付 DATE
8th Sep.
2010図番
NO.

AD16231E

改番 REV
00

8 / 11

SP.NO.

Yamatake Corporation

製品仕様書
SPECIFICATIONS

6. Maintenance and Troubleshooting

Phenomenon	Remedy
No output signal.	<ul style="list-style-type: none"> • Check that the supplied power and polarity are correct. • Check that the connector is connected correctly and firmly.
There is an output signal when actual flow rate is zero.	<ul style="list-style-type: none"> • Check for gas leaks from the piping. • Check that the wiring is correct.
The output signal does not correspond to the actual flow rate.	<ul style="list-style-type: none"> • Check for gas leaks from the piping. • Check that the fluid does not contain dust or mist. If it does, the sensor may have been damaged. If the sensor is damaged, replace the flowmeter and install an appropriate filter or the like. • Check that the wiring is correct. • Check that the flow does not pulsate and that the flow rate does not fluctuate widely or greatly exceed the measurement range. • Check that the external load resistance is not more than 500 kΩ.

Because the MRG has high detection sensitivity, the output may be shifted from the zero point due to ambient air currents, in the condition that it is turned on and the inlet and outlet port are open. When monitoring the output of the MRG without piping for an easy check of whether it is damaged, first cover the inlet and outlet with tape, etc.

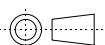
作成 DR. K.Niikawa		尺度 SCALE ~	記入のない公差 TOL.UNLESS NOTED ~
検図 CHK. H.Inagaki	形番 MODEL	MRG0002GAQP0001	
認可 APPD K.Harada	名称 NAME	Mass Flow Meter used for household fuel cells	
日付 DATE 8th Sep. 2010	図番 NO.	AD16231E	改番 REV 00 / 9 / 11

頁

改番

改番
REV.来歴
RECORD日付
DATE担当
BY認可
APPD.日付 DATE
8th Sep.
2010図番
NO.

AD16231E

改番 REV
00

9 / 11

Model No. label
(model No./date manufactured, etc.)

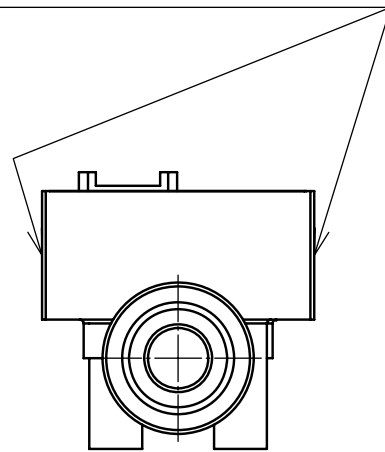

Connector
made by J.S.T. Mfg. Co., Ltd.
BM04B-XASS-TF

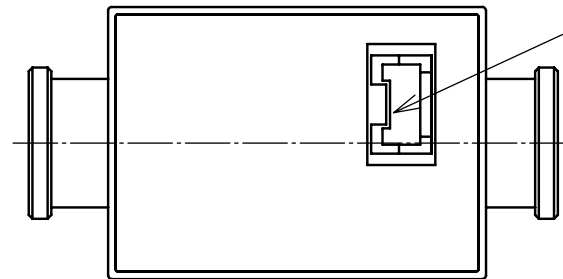

Coupler for Quick Fastener piping
in the case of P10 O-ring
(prepared by user)

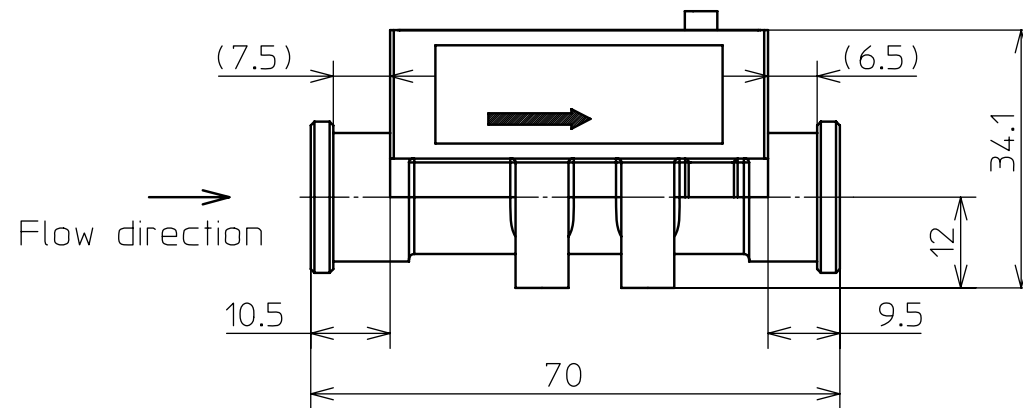
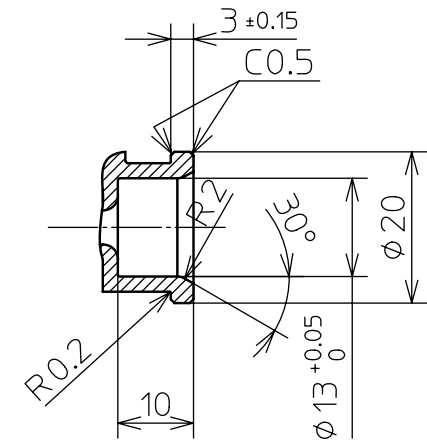

M screws (3), 5 mm min.
(recommended tightening torque: 0.6 N·m)

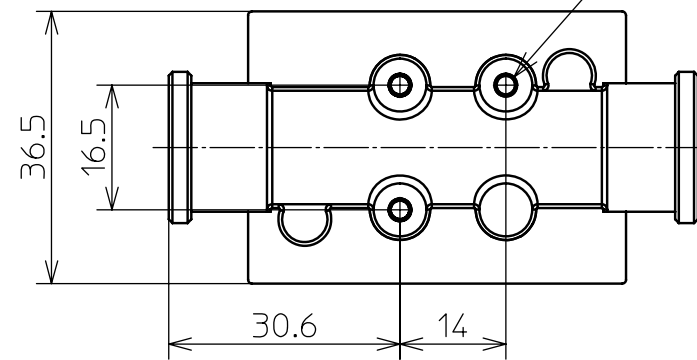

作成DR. K.Niikawa		尺度SCALE UN	記入のない公差 TOL. UNLESS NOTED ±0.5
検図CHK. H.Inagaki	形番 MODEL	MRG0002GAQP0001	
認可APPD K.Harada	名称 NAME	Mass Flow Meter used for household fuel cells	
改番 REV.	来歴 RECORD	日付 DATE	担当 BY
8th Sep. 2010			検閲 APPD.
	図番 NO.	改番REV.	10/11
	AD16231E	00	

S.P. No.

Yamatake Corporation

製品仕様書
SPECIFICATIONS

10 units/box
Separately packed in plastic bag

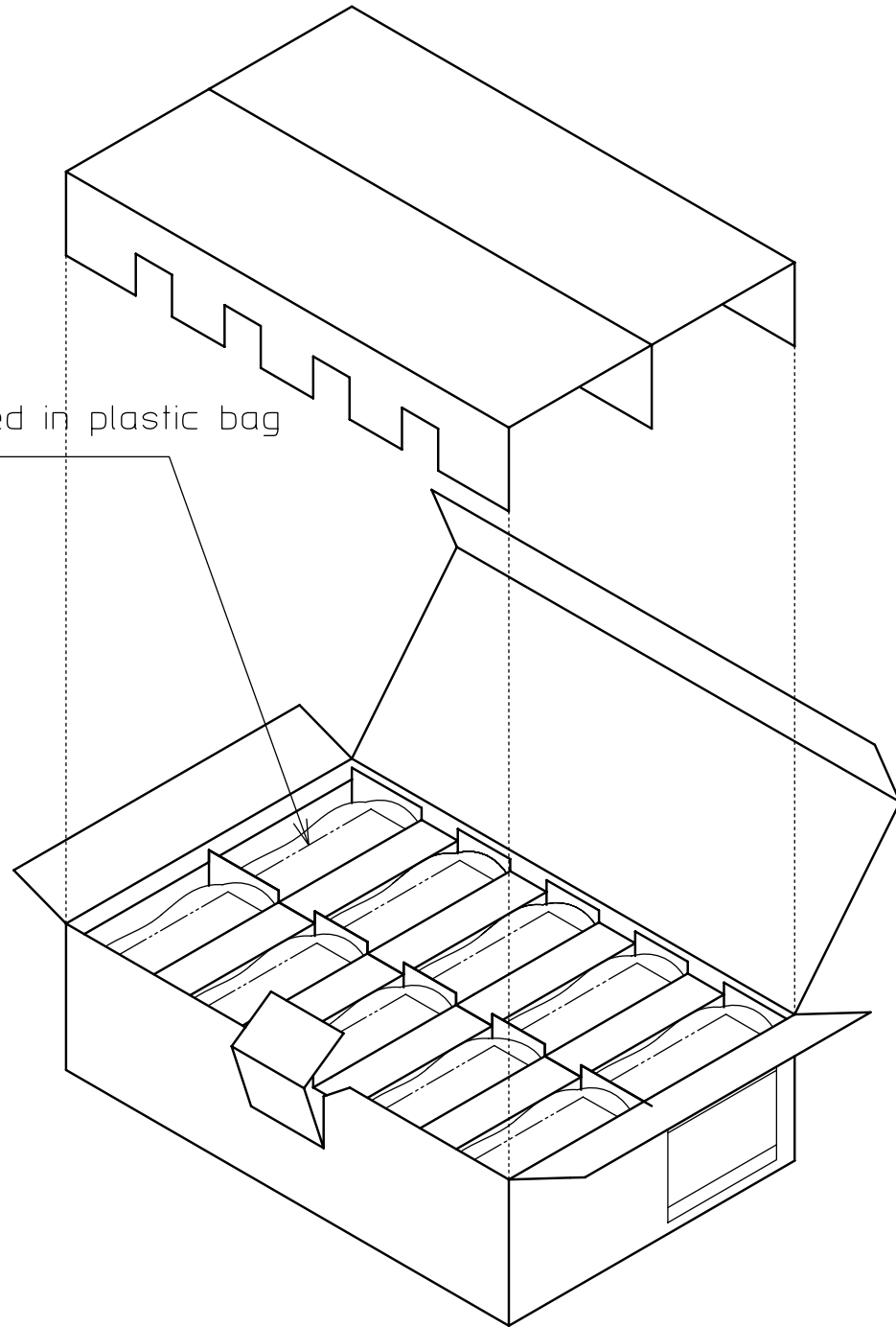

Model No. label
(model No./Q'ty etc.)

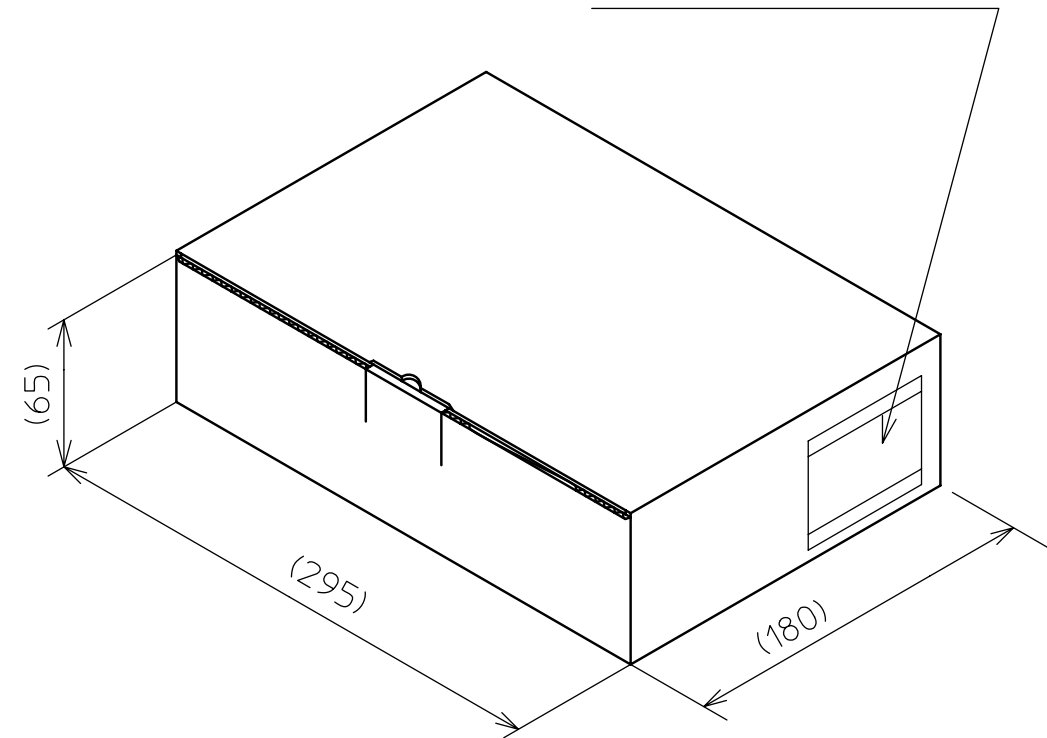

作成DR. K.Niikawa		尺度SCALE UN	記入のない公差 TOL. UNLESS NOTED
検図CHK. H.Inagaki	形番 MODEL	MRG0002GAQP0001	
認可APPD. K.Harada	名称 NAME	Mass Flow Meter used for household fuel cells	
日付DATE 8th Sep. 2010	図番 NO.	AD16231E	改番REV. 11/11 00

改番 REV.	来歴 RECORD	: 日付 DATE	担当 BY	検閲 APPD.
------------	--------------	--------------	----------	-------------

SP. NO.	Yamatake Corporation		製品仕様書 SPECIFICATIONS			
	Terms and Conditions					
	<p>We would like to express our appreciation for your purchase and use of Yamatake products. You are required to acknowledge and agree upon the following terms and conditions for your purchase of Yamatake products (field instruments, control valves, and control products), unless otherwise stated in any separate document, including, without limitation, estimation sheets, written agreements, catalogs, specifications and instruction manuals.</p>					
	<p>1 Warranty period and warranty scope</p>					
	<p>1.1 Warranty period Yamatake products shall be warranted for one (1) year from the date of your purchase of the said products or the delivery of the said products to a place designated by you.</p>					
	<p>1.2 Warranty scope In the event that Yamatake product has any failure attributable to Yamatake during the aforementioned warranty period, Yamatake shall, without charge, deliver a replacement for the said product to the place where you purchased, or repair the said product and deliver it to the aforementioned place. Notwithstanding the foregoing, any failure falling under one of the following shall not be covered under this warranty:</p>					
	<p>(1) Failure caused by your improper use of Yamatake product (noncompliance with conditions, environment of use, precautions, etc. set forth in catalogs, specifications, instruction manuals, etc.);</p>					
	<p>(2) Failure caused for other reasons than Yamatake product;</p>					
	<p>(3) Failure caused by any modification or repair made by any person other than Yamatake or Yamatake's subcontractors;</p>					
	<p>(4) Failure caused by your use of Yamatake product in a manner not conforming to the intended usage of that product;</p>					
	<p>(5) Failure that the state-of-the-art at the time of Yamatake's shipment did not allow Yamatake to predict; or</p>					
	<p>(6) Failure that arose from any reason not attributable to Yamatake, including, without limitation, acts of God, disasters, and actions taken by a third party.</p>					
	<p>Please note that the term "warranty" as used herein refers to equipment-only-warranty, and Yamatake shall not be liable for any damages, including direct, indirect, special, incidental or consequential damages in connection with or arising out of Yamatake products.</p>					
	<p>2 Ascertainment of suitability</p>					
	<p>You are required to ascertain the suitability of Yamatake product in case of your use of the same with your machinery, equipment, etc. (hereinafter referred to as "Equipment") on your own responsibility, taking the following matters into consideration:</p>					
	<p>(1) Regulations and standards or laws that your Equipment is to comply with.</p>					
	<p>(2) Examples of application described in any documents provided by Yamatake are for your reference purpose only, and you are required to check the functions and safety of your Equipment prior to your use.</p>					
	<p>(3) Measures to be taken to secure the required level of the reliability and safety of your Equipment in your use</p>					
	<p>Although Yamatake is constantly making efforts to improve the quality and reliability of Yamatake products, there exists a possibility that parts and machinery may break down. You are required to provide your Equipment with fool-proof design, fail-safe design, anti-flame propagation design, safety design, or the like so that the said Equipment may satisfy the level of the reliability and safety required in your use, whereby preventing any occurrence of physical injuries, fires, significant damage, and so forth.</p>					
	<p>3 Precautions and restrictions on application</p>					
	<p>Yamatake products other than those explicitly specified as applicable (e.g. Yamatake Limit Switch For Nuclear Energy) shall not be used in a nuclear energy controlled area (radiation controlled area). Any Yamatake products shall not be used for/with medical equipment. In addition, you are required to conduct a consultation with our sales representative and understand detail specifications, cautions for operation, and so forth by reference to catalogs, specifications, instruction manual, etc. in case that you intend to use Yamatake product for any purposes specified in (1) through (6) below. Moreover, you are required to provide your Equipment with fool-proof design, fail-safe design, anti-flame propagation design and other designs of protection/safety circuit on your own responsibility to ensure the reliability and safety, whereby preventing problems caused by failure or nonconformity.</p>					
	<p>(1) For use under such conditions or in such environments as not stated in technical documents, including catalogs, specification, and instruction manuals</p>					
	<p>(2) For use of specific purposes, such as:</p>					
	<p>* Nuclear energy/radiation related facilities [For use outside nuclear energy controlled areas] [For use of Yamatake Limit Switch For Nuclear Energy]</p>					
	<p>* Machinery or equipment for space/sea bottom</p>					
	<p>* Transportation equipment [Railway, aircraft, vessels, vehicle equipment, etc.]</p>					
	<p>* Antidisaster/crime-prevention equipment</p>					
	<p>* Burning appliances</p>					
	<p>* Electrothermal equipment</p>					
	<p>* Amusement facilities</p>					
頁	改番	改番	来歴	日付	担当	検閲
		REV.	RECORD	DATE	BY	APPD.

