

Compact Operation Unit SDU10

for Modular Controller DMC10

User's Manual

Thank you for purchasing the Compact Operation Unit SDU10 for Modular Controller DMC10.

This manual contains information for ensuring correct use of the SDU10. It also provides necessary information for installation, maintenance, and troubleshooting. This manual should be read by those who design and maintain devices that use the SDU10.

Be sure to keep this manual nearby for handy reference.

Contents

1. INTRODUCTION & SYSTEM CONFIGURATION ...	1
2. NAMES & FUNCTIONS OF PARTS.....	2
3. MOUNTING.....	2
4. WIRING.....	4
5. OPERATION PROCEDURES.....	6
6. RECIPE FUNCTION.....	18
7. HOST COMMUNICATIONS FUNCTION.....	19
8. ALARM CODES.....	20
9. SPECIFICATIONS.....	21
Appendix 1.USER-DEFINED ITEM NAMES.....	22
Appendix 2.USE OF AN SDU10 AS A SLAVE.....	23
Appendix 3.SDU10 INTERNAL SETUP DATA	
BATCH COPY FUNCTION.....	24
Appendix 4.SDU10 COMMUNICATIONS	
PARAMETER TABLES.....	26

Yamatake Corporation

RESTRICTIONS ON USE

When using this product in applications that require particular safety or when using this product in important facilities, pay attention to the safety of the overall system and equipment. For example, install fail-safe mechanisms, carry out redundancy checks and periodic inspections, and adopt other appropriate safety measures as required.

REQUEST

Make sure that this Instruction Manual is handed over to the user before the product is used.

Copying or duplicating this User's Manual in part or in whole is forbidden. The information and specifications in this User's Manual are subject to change without notice.

Considerable effort has been made to ensure that this User's Manual is free from inaccuracies and omissions.

If you should find any inaccuracies or omissions, please contact Yamatake Corporation.

In no event is Yamatake Corporation liable to anyone for any indirect, special or consequential damages as a result of using this product.

This manual uses the following symbols to ensure safe operation of this device.



WARNING

Warnings are indicated when mishandling this product might result in death or serious injury to the user.



CAUTION

Cautions are indicated when mishandling this product might result in minor injury to the user, or only physical damage to this product.



WARNING



Note that incorrect wiring of the SDU10 can damage the SDU10 and lead to other hazards. Check that the SDU10 has been correctly wired before turning the power ON.



**Before wiring, or removing/mounting the SDU10, be sure to turn the power OFF.
Failure to do so might cause faulty operation.**



**Do not disassemble the SDU10.
Doing so might cause faulty operation.**



CAUTION



**Do not operate the keys with a propelling pencil or sharp-tipped object.
Doing so might cause faulty operation.**



**Use the SDU10 within the operating ranges recommended in the specifications (temperature, humidity, voltage, vibration, shock, mounting direction, atmosphere, etc.).
Failure to do so might cause fire or faulty operation.**



**The SDU10 used with the rubber packing enclosed in the package satisfies the requirements equivalent to IP65. Use the rubber packing for the high humidity or much dust environment.
Failure to do so might cause fire or faulty operation.**



**Do not block ventilation holes.
Doing so might cause fire or faulty operation.**



**Wire the SDU10 properly according to predetermined standards. Also wire the SDU10 using specified power leads according to recognized installation methods.
Failure to do so might cause fire or faulty operation.**



**Do not allow leads clippings, chips or water to enter the controller case.
Doing so might cause fire or faulty operation.**



**Firmly tighten the terminal screws at the torque listed in the specifications.
Insufficient tightening of terminal screws might cause fire.**



**Do not use unused terminals on the SDU10 as relay terminals.
Doing so might cause fire or faulty operation.**



**Use Yamatake Corporation's SurgeNon if there is the risk of power surges caused by lightning.
Failure to do so might cause fire or faulty operation.**

Unpacking

Check the following items when removing the **SDU10** from its package.

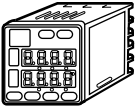
Name	Model No.	Q'ty	Remarks
Body 	SDU10T0100	1	
Mounting bracket	81446403-001	1	
User's Manual	CP-SP-1096E	1	This manual
Unit indicator seal		1	
Rubber packing		1	

After unpacking, handle the **SDU10** and its accessories taking care to prevent damage or loss of parts. If an inconsistency is found or the package contents are not in order, immediately contact your dealer.

Conventions Used in This Manual

The following conventions are used in this manual.

Handling Precautions

: Handling Precautions indicate items that the user should pay attention to when handling the **SDU10**.

Note

: Notes indicate useful information that the user might benefit by knowing.

1. INTRODUCTION & SYSTEM CONFIGURATION

■ Introduction

The SDU10 is a compact operation display unit for the Modular Controller DMC10. The features of the SDU10 are as follows:

- The compact size of the SDU10 enables it to be installed in restricted spaces.
- Only the necessary number of locations can be monitored and operated.
- The SDU10 can be used as a monitor/operation device especially for on-site use in addition to use as a communications device with a personal computer, touch panel or other host device.
- The recipe function enables DMC setup parameters (SP, P, I, D, etc.) that differ according to product lot to be stored internally on the SDU10 so that they can be batch changed by key operation, external switch input and communications.

■ System Configuration

● Instrumentation example 1: When there is no host device

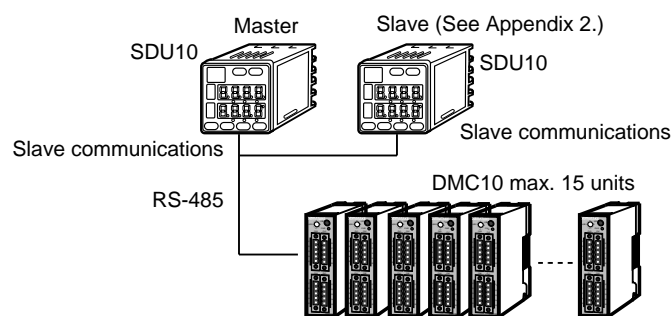

● Instrumentation example 2: When there is a host device

For details on the host communications function, see “7. HOST COMMUNICATIONS FUNCTION” (page 19).

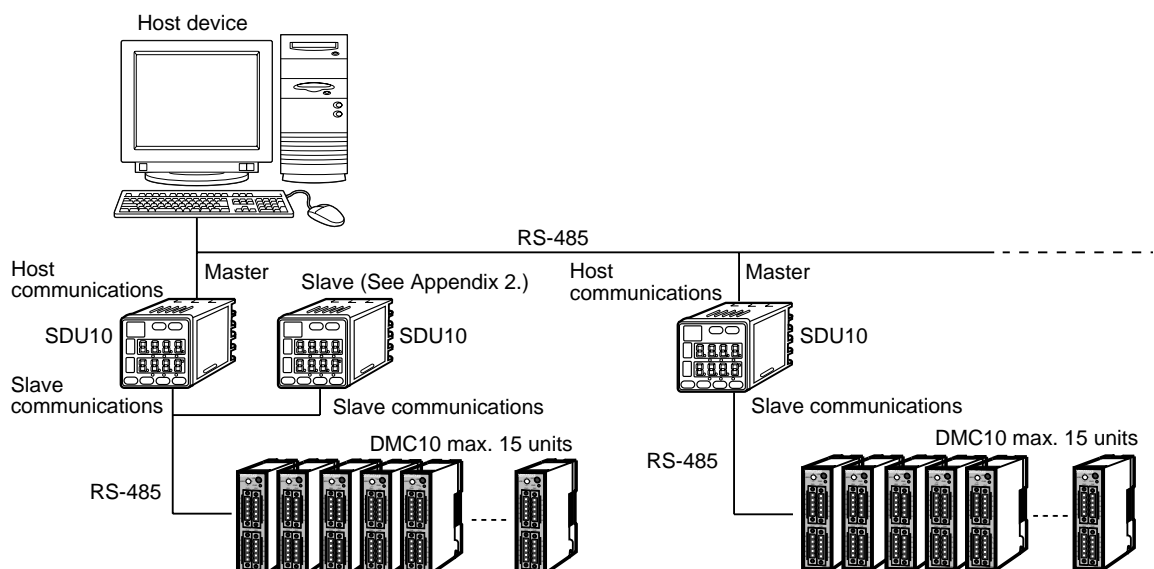

! Handling Precautions

- The RS-232C↔RS-485 converter is needed when performing communications with the host device (including the EST240Z touch panel) on the RS-232C interface. The Yamatake Corporation CMC10L can also be used.
- When accessing the DMC10 from the host device via the SDU10, pay attention to the following time-out setting condition. Accessing of SDU10 data is determined by SDU10 setup C04.
Condition: Set the time-out for when there is no response to at least one second.
- The SDU10 cannot be used together with the CMC10A or B.

2. NAMES & FUNCTIONS OF PARTS

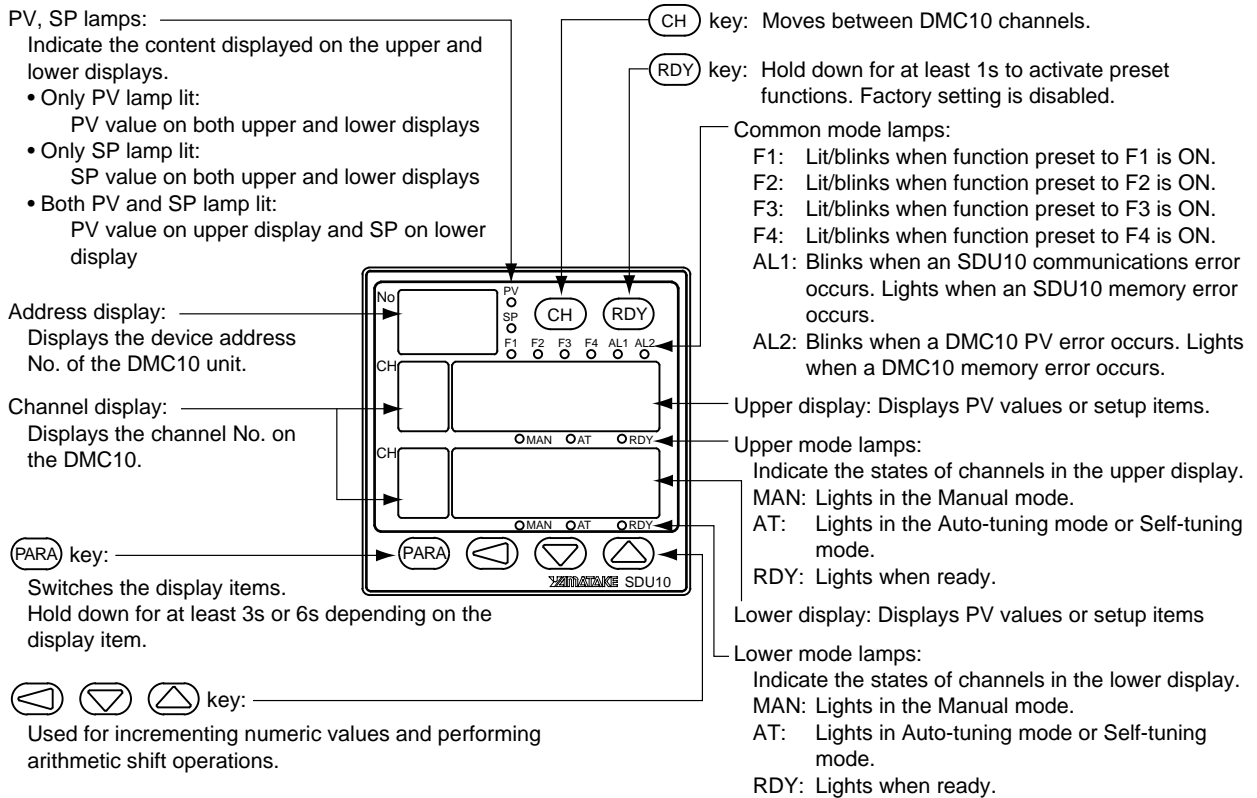

3. MOUNTING

External Dimensions

Unit: mm

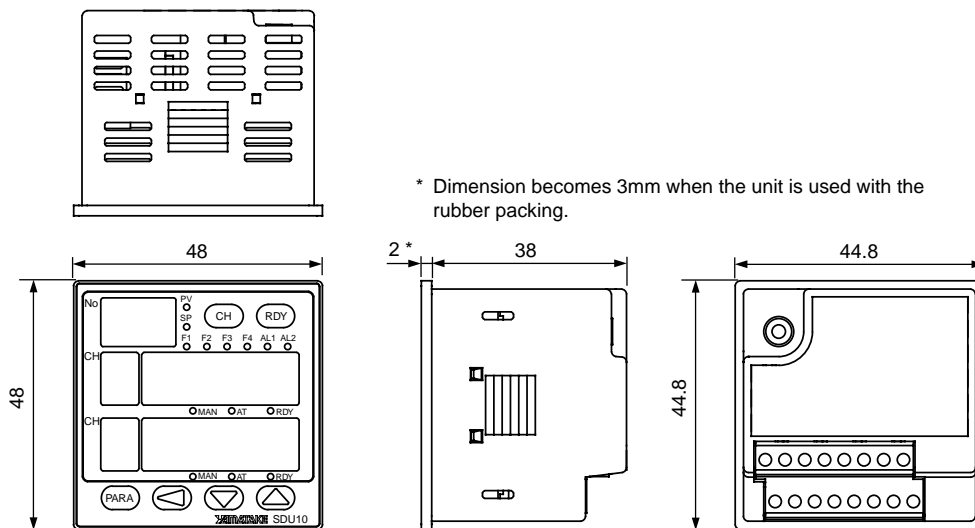

Panel Cutout

Unit: mm

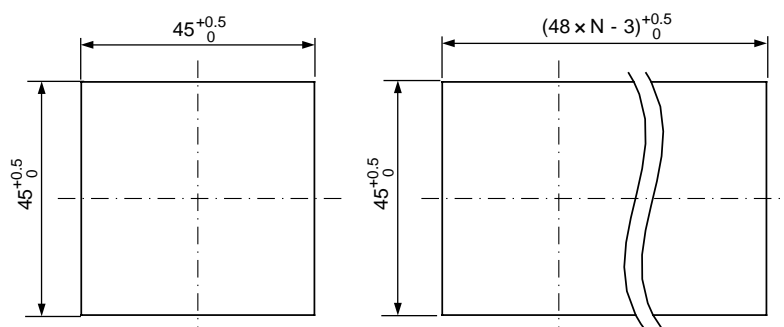

■ Mounting Locations

Do not install the SDU10 in locations where it is:

- subject to extreme temperature and humidity
- subject to sulfuric or corrosive gases
- subject to dust or oil smoke
- subject to direct sunlight, or splashing by rain or water
- subject to mechanical vibrations and shock
- subject to high-voltage lines, welding machines and sources of electric noise
- less than 15m from high-voltage ignition devices
- subject to electromagnetic fields
- subject to flammable liquids or vapor

❗ Handling Precautions

The inside of the SDU10 cannot be drawn out of its case.

■ Mounting Method

⚠ CAUTION



Use the SDU10 within the operating ranges recommended in the specifications (temperature, humidity, voltage, vibration, shock, mounting direction, atmosphere, etc.).

Failure to do so might cause fire or faulty operation.



The SDU10 used with the rubber packing enclosed in the package satisfies the requirements equivalent to IP65. Use the rubber packing for the high humidity or much dust environment.

Failure to do so might cause fire or faulty operation.



Do not block ventilation holes.

Doing so might cause fire or faulty operation.

● Required tools

Phillips screwdriver for turning
M2.5 screws

● Procedure

- ① Insert the SDU10 into the opening on the front side of the panel.
- ② Attach the mounting bracket at the rear side of the panel.
- ③ Press the SDU10 against the mounting bracket to make sure that the bracket claws enter the grooves of the controller.
- ④ Tighten the top and bottom screws. (When the screws touch the panel, turn the screws another half turn.)

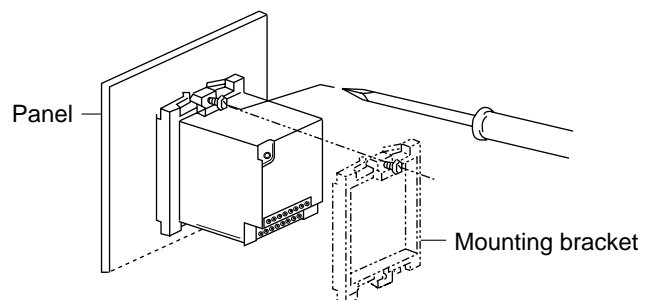

❗ Handling Precautions

- Do not operate the keys with a propelling pencil or sharp tipped object. Be sure to mount this SDU10 on a panel.
- Do not overtighten the screws to prevent deformation of the front panel.

4. WIRING

■ Terminal Array and Wiring

⚠ WARNING



Before wiring, or removing/mounting the SDU10, be sure to turn the power OFF. Failure to do so might cause faulty operation.



Do not touch electrically charged parts such as the power terminals. Doing so might cause electric shock.

⚠ CAUTION



Wire the SDU10 properly according to predetermined standards. Also wire the SDU10 using specified power leads according to recognized installation methods.

Failure to do so might cause fire or faulty operation.



Do not allow leads clippings, chips or water to enter the controller case. Doing so might cause fire or faulty operation.



Firmly tighten the terminal screws at the torque listed in the specifications. Insufficient tightening of terminal screws might cause fire.



Do not use unused terminals on the SDU10 as relay terminals. Doing so might cause fire or faulty operation.



Use Yamatake Corporation's SurgeNon if there is the risk of power surges caused by lightning.

Failure to do so might cause fire or faulty operation.



Make sure all wiring is correct. Incorrect wiring may damage connected equipment.



The SDU10 does not operate for 15s after the power has been turned ON. Special arrangements must be made when the device signals are to be used as an interlock signal.

● Wiring diagrams

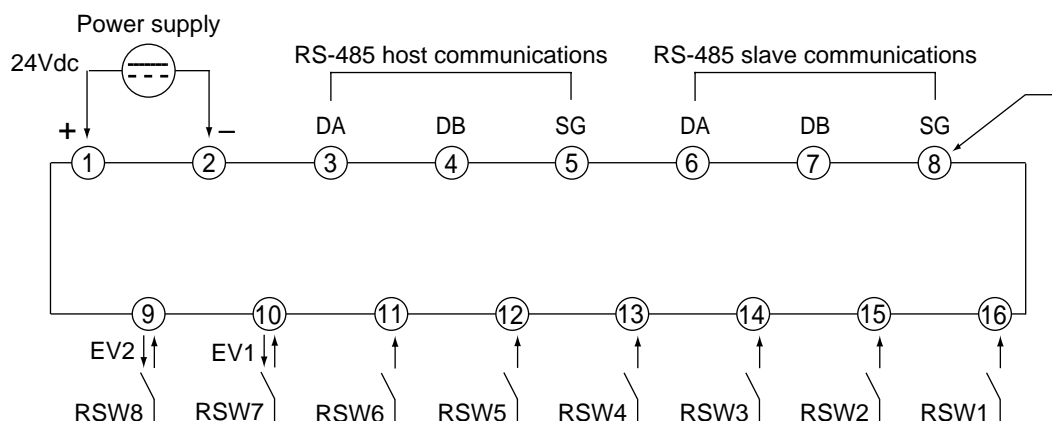

! Handling Precautions

- Check the model number of the display unit and terminal numbers on the label on the side of the display unit to prevent any wiring errors.
- When wiring, take care to prevent leads from contacting adjacent terminals.
- Do not use unused terminals as relay terminals.
- Two or more SDU10 display units can be connected in parallel by external switch input.
- The display unit can be connected with the Yamatake Corporation SDC10/20/30/40 series in parallel by external switch input.
- Before connecting in parallel to other equipment, first check the conditions of the other equipment.
- A common terminals is used for external switch input (RSW7, 8) and event output (EV1, 2). To use only external switch input, do not set event output. Alternately, do not set external switch input when only event output is to be used. The following figure shows the circuit configuration of this terminal.

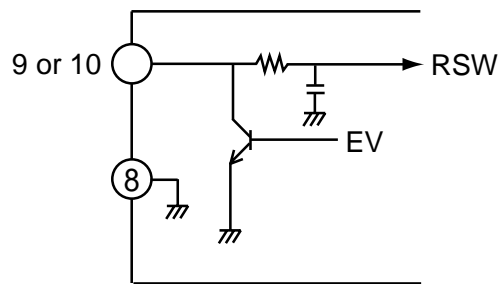

■ Meaning of Symbols in the Terminal Wiring Label

The following table shows the meanings of symbols in the terminal wiring label on the side of the instrument.

Symbol	Description
---	Direct current
⚠	CAUTION

● Cable specifications

- Wire type: Single wire and twisted wire both acceptable
- Wire type: 0.13 to 1.31mm² (AWG26 to 16)
- Recommended length of bare wire at wire terminal: 4mm

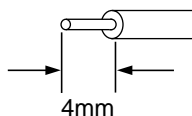

5. OPERATION PROCEDURES

Complete the setup for slave DMC10s before setting up the SDU10.

See Page
8

Step 1 Set SDU10 setup items. (Move by holding down **PARA** key for 6s from DMC10 monitor.)
Make the initial settings on the SDU10 itself.



Step 2 Execute C27 (execute automatic detection).

13



Step 3 Set recipe items. (Move by holding down **PARA** key for 3s in state in Step 2.)
Set the recipe items only when the recipe functions are used. For details, see "6. RECIPE FUNCTION."

14



Step 4 Read DMC10 parameters for recipes. (Move by holding down **PARA** key for 3s in state in Step 3.)
Perform this operation only when the recipe functions are used.

14

How to Set up Data

Procedure

- Enter numeric values with the **▲** **▼** **◀** keys.

- ▶ Numeric values blink for about 2s. During blinking, the **PARA** key cannot be used.

Blinking stops to indicate that the data has been set.

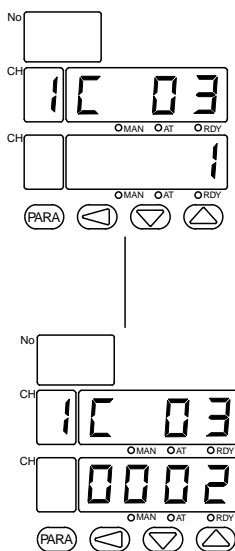

(Note)

"Loc" is displayed in the lower display for about 2s to indicate that an incorrect key or data entry was made. Such entries are ignored.

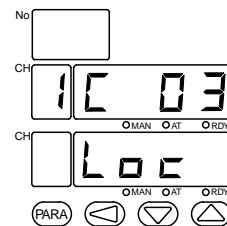

Overall Operation Flow

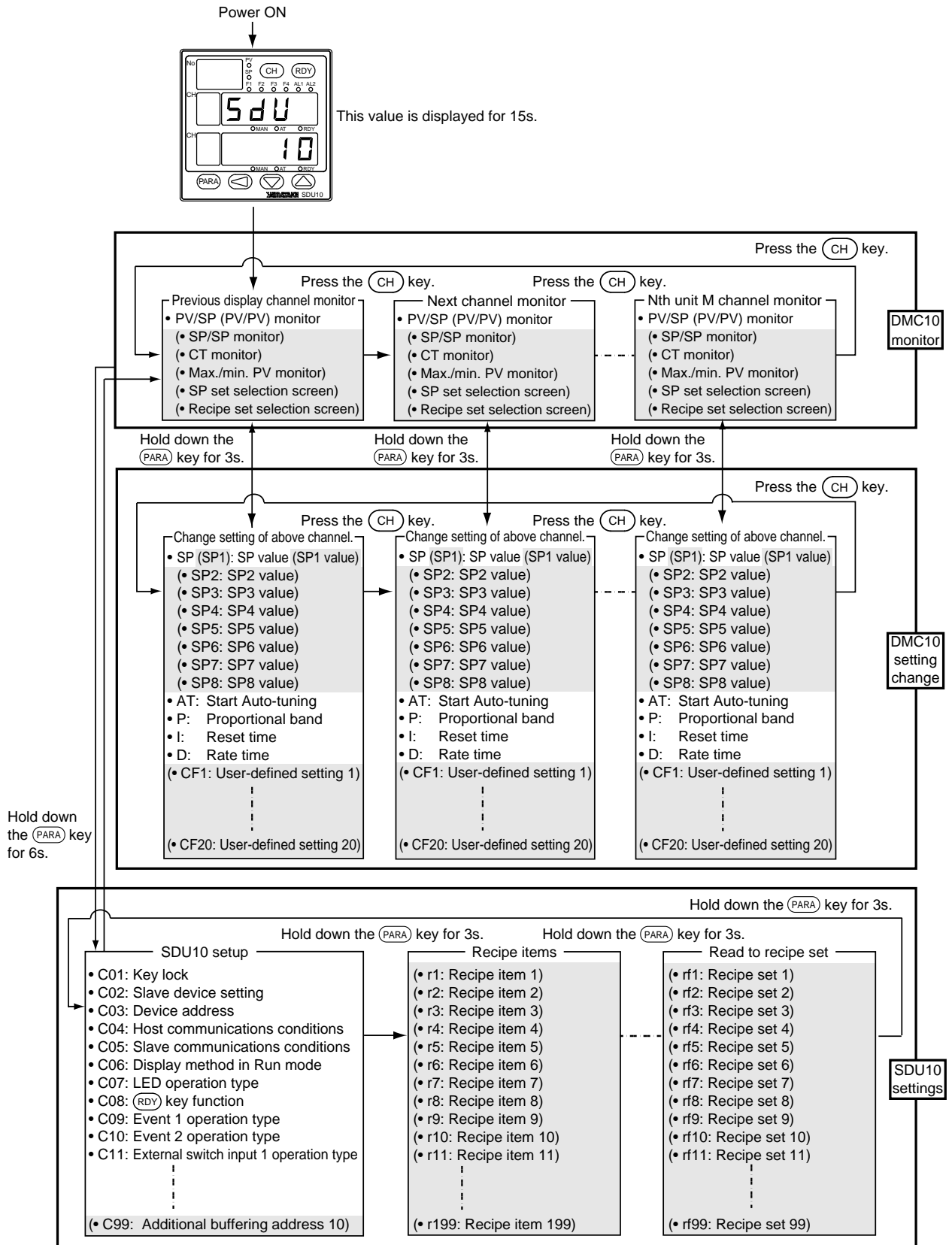

Note

- The “previous displayed channel” refers to the device address and channel of the DMC10 that was last monitored, and monitoring starts from that address and channel. The hatched section are sometimes not displayed depending on the SDU10 setup details. The next parameter is moved to within each group by pressing the (PARA) key as normal.
- For details of actual displays, refer to **DMC10 Monitoring** (page 14).

■ List of SDU10 Setup Items

M: Setting enabled when in the Master mode

M, S: Setting enabled when in either the Master or Slave mode

*: Use DMC10 version 7.XX onwards.

Function Prompt	Item	Description	Factory Setting	Master/Slave
C01	Key lock	0: Key lock not engaged 1: All setup item parameters excluding key lock cannot be set. 2: Key lock and DMC10 cannot be set. 3: All parameters excluding key lock cannot be set.	0	M, S
C02	Slave device setting	0: Master 1: Slave	0	M, S
C03	Device address	0 to 127: Address conversion OFF	0	M, S
C04	Host communications settings	1st digit: Transmission speed 0: 4800bps 1: 9600bps 2: 19200bps 2nd digit: Communication format 0: 8bits, even parity, 1 stop bit 1: 8bits, no parity, 2 stop bits 2: 7bits, even parity, 1 stop bit 3: 7bits, no parity, 2 stop bits 3rd digit: Min. communications response time 0: 1ms 1: 10ms 2: 100ms 3: 200ms 4th digit: Communications protocol 0: CPL 1: MOD BUS (ASCII) 2: MOD BUS (binary)	0002	M, S
C05	Slave communications settings	1st digit: Transmission speed 0: 4800bps 1: 9600bps 2: 19200bps 2nd digit: Communication format 0: 8bits, even parity, 1 stop bit 1: 8bits, no parity, 2 stop bits 2: 7bits, even parity, 1 stop bit 3: 7bits, no parity, 2 stop bits 3rd digit: Communications time-out 0: 500ms 1: 1000ms 2: 2000ms	0002	M, S
C06	Display method in Run mode	1st digit: Basic display (upper/lower) 0: PV/SP display 1: PV/PV display 2: PV/PV display + SP/SP display 3: PV/SP display + CT display 4: PV/PV display + CT display 5: PV/PV display + SP/SP display + CT display 2nd digit: Min./max. CT/PV value display 0: Does not display 1: Min./Max. PV value display 2: Min./Max. PV value display (peak hold) 3rd digit: SP set change/recipe set change screen display 0: Does not display 1: SP set selection screen only 2: Recipe set selection screen only 3: SP set selection screen + recipe set selection screen 4th digit: Fixed/scan display mode selection 0: Fixed display 1: Scan display	0000	M

Function Prompt	Item	Description	Factory Setting	Master/Slave
C39	User-defined item 10 address	256 to 9999: Set the address of items to be added in the DMC10 Setup screen.	256	M
C40	User-defined item 11 address			
C41	User-defined item 12 address			
C42	User-defined item 13 address			
C43	User-defined item 14 address			
C44	User-defined item 15 address			
C45	User-defined item 16 address			
C46	User-defined item 17 address			
C47	User-defined item 18 address			
C48	User-defined item 19 address			
C49	User-defined item 20 address			
C50	User-defined item 1 name	Can be entered using the characters in Appendix 1.	CF1	M
C51	User-defined item 2 name		CF2	M
C52	User-defined item 3 name		CF3	M
C53	User-defined item 4 name		CF4	M
C54	User-defined item 5 name		CF5	M
C55	User-defined item 6 name		CF6	M
C56	User-defined item 7 name		CF7	M
C57	User-defined item 8 name		CF8	M
C58	User-defined item 9 name		CF9	M
C59	User-defined item 10 name		CF10	M
C60	User-defined item 11 name		CF11	M
C61	User-defined item 12 name		CF12	M
C62	User-defined item 13 name		CF13	M
C63	User-defined item 14 name		CF14	M
C64	User-defined item 15 name		CF15	M
C65	User-defined item 16 name		CF16	M
C66	User-defined item 17 name		CF17	M
C67	User-defined item 18 name		CF18	M
C68	User-defined item 19 name		CF19	M
C69	User-defined item 20 name		CF20	M
C70	User-defined item 1 decimal point	0: No decimal point 1: Decimal point No.1 2: Decimal point No.2 3: Decimal point No.3	0	M
C71	User-defined item 2 decimal point			
C72	User-defined item 3 decimal point			
C73	User-defined item 4 decimal point			
C74	User-defined item 5 decimal point			
C75	User-defined item 6 decimal point			
C76	User-defined item 7 decimal point			
C77	User-defined item 8 decimal point			
C78	User-defined item 9 decimal point			
C79	User-defined item 10 decimal point			
C80	User-defined item 11 decimal point			
C81	User-defined item 12 decimal point			
C82	User-defined item 13 decimal point			
C83	User-defined item 14 decimal point			
C84	User-defined item 15 decimal point			
C85	User-defined item 16 decimal point			
C86	User-defined item 17 decimal point			
C87	User-defined item 18 decimal point			
C88	User-defined item 19 decimal point			
C89	User-defined item 20 decimal point			
C90	Additional buffering address 1	256 to 9999: Sets the address of items to be additionally buffered.	256	M
C91	Additional buffering address 2			
C92	Additional buffering address 3			
C93	Additional buffering address 4			
C94	Additional buffering address 5			
C95	Additional buffering address 6			
C96	Additional buffering address 7			
C97	Additional buffering address 8			
C98	Additional buffering address 9			
C99	Additional buffering address 10			

■ Item Descriptions

● C02 (slave device setting)

This item enables the display of data in the master device on a specified slave device. This item is mainly used for monitoring all PV values simultaneously on a 4-channel model. PV values are only displayed on the slave device, and key operations are disabled except for setup items.

● C03 (device address)

This item need not be set when host communications is not performed.

For details, see “7. HOST COMMUNICATIONS FUNCTION” (page 19).

When adding an SDU10 to instrumentation that was communicating directly with a DMC10, set this item to “0”.

The device address must be specified, for example, when there are 16 or more DMC10s.

When MODBUS is set for the host communication conditions, the host communications cannot be performed for the 16 to 127 setting.

● C06 (display method in Run mode)

“Min./max. value display” refers to display of the minimum value (lower display) and maximum value (upper display) of all PV values of all DMC10s currently connected to the SDU10.

“Scan display” is a function for automatically switching and displaying channels at 4-second intervals. The values of all channels can be monitored even from a remote locations as key operation is not required.

● C07 (LED operation type)

This item is for setting the operation conditions for LEDs F1 to F4 on the front panel.

For setting “3: DMC10 communications DI input state,” use DMC10 version 7.XX onwards.

● C08 (RDY key function)

1st digit 1: RUN/READY (all modules, all channels):

RUN/READY operation is executed on all channels based upon the RUN/READY state of the channel currently displayed on the upper display.

Use DMC10 version 7.XX onwards.

1st digit 3: Auto-tuning (all modules, all channels):

Auto-tuning is executed on all channels based upon the auto-tuning state of the channel currently displayed on the upper display.

Use DMC10 version 7.XX onwards.

1st digit 2: RUN/READY (indicated module, upper display channel),

4: Auto-tuning (indicated module, upper display channel)

Auto-tuning is executed on the channel currently displayed on the upper display.

1st digit For “5: SP set switching”, use DMC10 version 7.XX onwards.

The 3rd digit is enabled only when “5: SP set switching” and “6: Recipe set switching” is set at the 1st digit.

● **C11 to 18 (external switch input operation type)**

Input is performed in binary in the case of SP set and recipe set switching.

Example: When RSW 3 to 5 are used when switching eight sets

	RSW5	RSW4	RSW3
SP1	OFF	OFF	OFF
SP2	OFF	OFF	ON
SP3	OFF	ON	OFF
SP4	OFF	ON	ON
SP5	ON	OFF	OFF
SP6	ON	OFF	ON
SP7	ON	ON	OFF
SP8	ON	ON	ON

1: RUN/READY (all channels)

2: Auto-tuning start/stop (all channels)

Use DMC10 version 7.XX onwards.

● **C19 (number of user-defined items)**

This item allows you to add up to 20 parameters from the entire DMC10 parameters in addition to existing items on the DMC10 setting change screen.

No additions are made when this item is set to “0”.

When “1” or more is set, set the desired items as related parameters are displayed from C30 onwards.

● **C20 (number of additional buffers)**

This item allows you to add up to ten data items on currently connected DMC10s in addition to currently buffered data. No additions are made when this item is set to “0”.

When “1” or more is set, set the desired items as related parameters are displayed from C90 onwards.

● **C21 (number of recipe items)**

This item is for setting the number of parameter types on the DMC10s per recipe. Up to 199 parameters can be set.

When the parameter items are different on each DMC10, execute this item by the total number of parameters in question for all DMC10s.

Example: If SP only is set for the 1st DMC10 and P, I and D are set for the 2nd DMC10, the number of recipe items to set here in this item is four (SP, P, I and D).

● **C22 (number of recipe sets)**

This item is for setting the number of recipe sets (maximum 99). Set so that the following restriction is satisfied:

Number of recipe items (C21) x number of recipe sets (C22) x number of DMC10 units ≤ 2860

● **C27 (execute automatic detection)**

When setting this item, it is presumed that all DMC10s have finished being set up, and that setup items *C01 to C22* on the SDU10 have been completed.

Executing this item stores the information of DMC10s currently connected to the SDU10 internally on the SDU10. Execute this item again when the settings of the DMC10s have been changed after this item has been executed.

During execution of this item, the display blinks, and blinking stops within 2min at most after execution is completed.

● **C28 (automatic detection results)**

This item allows you to check the number of currently connected DMC10s after execution of automatic detection (*C27*) is completed.

● **C30 to C49 (user-defined item addresses)**

This item is for setting the item address Nos. to be added.

For a list of addresses, see Modular Controller DMC10 User's Manual Description of Functions CP-UM-5143E.

● **C50 to C69 (user-defined item name)**

This item is for setting the names of items actually displayed in setting screen.

The characters and symbols in "Appendix 1. USER-DEFINED ITEM NAMES" (page 22) can be used.

● **C70 to C89 (user-defined item decimal point)**

This item is for setting a decimal point if decimal point information is required for numbers in screens that are set by setup items *C50 to C69*.

The information set here is for display only.

● **C90 to C99 (additional buffering addresses)**

"Additional buffering addressing" is a handy function for reading required parameters by host communications.

SDU10 is provided with memory area for storing the latest data. Data required for running of the SDU10 is stored on the SDU10 at all times. This data is called "buffered parameters."

In addition to already determined parameter types (PV, SP, alarm states, etc.), up to ten extra types of parameters can be defined as desired as buffered parameters for each DMC10 unit.

As the parameters that are handled by host communications are arranged continuously on SDU10 internal memory, these buffered parameters can be read from the host device using the minimum number of commands.

Normally, buffered parameters are read from the DMC10 at roughly 15-second cycles and are updated. However, it sometimes takes 30 seconds or more to read buffered parameters, for example, during writing of recipes.

For a list of addresses, see Modular Controller DMC10 User's Manual Description of Functions CP-UM-5143E.

■ List of SDU10 Recipe Items

M: Setting enabled when in the Master mode

Function Prompt	Item	Description	Factory Setting	Master/Slave
<i>r1</i>	Recipe item 1	Refer to the DMC10 User's Manual.	256	M
<i>r2</i>	Recipe item 2			
<i>r3</i>	Recipe item 3			
<i>r4</i>	Recipe item 4			
<i>r5</i>	Recipe item 5			
⋮	⋮			
<i>r199</i>	Recipe item 199			

Set the parameter addresses of the connected DMC10 for *r1* to *r199* (recipe items).

■ List of SDU10 Recipe Sets

M: Setting enabled when in the Master mode

Function Prompt	Item	Description	Factory Setting	Master/Slave
<i>rf1</i>	Recipe set 1	0: Disabled 1: Start reading of parameters <i>rf1</i> to <i>rf99</i> from the connected DMC10.	0	M
<i>rf2</i>	Recipe set 2			
<i>rf3</i>	Recipe set 3			
<i>rf4</i>	Recipe set 4			
<i>rf5</i>	Recipe set 5			
⋮	⋮			
<i>rf99</i>	Recipe set 99			

Start reading of the recipe items from the DMC10 connected here for *rf1* to *rf199* (recipe sets).

Execute reading at the set No. of the recipe in question.

Setting “1” starts reading, and the display blinks. When reading ends, blinking stops.

Setting “0” disables that recipe set No.

■ DMC10 Monitoring

Function Prompt	Item	Description	Factory Setting	Remarks
Upper display: PV value Lower display: SP value or PV value	Basic display	Display details can also be displayed by setting C06 on SDU10. Can also be displayed on slave units.	—	
Upper display: SP value Lower display: SP value	SP display	Displays only when basic display is PV (upper display) and PV (lower display). Can also be displayed on slave units.	—	C06: XXX2
Upper display: $\bar{E} \bar{E} 1$ Lower display: CT1 value	CT1 current value	Displayed only on model Nos. with CT. Can also be displayed on slave units.	—	C06: XX1X or C06: XX3X
Upper display: $\bar{E} \bar{E} 2$ Lower display: CT 2 value	CT2 current value	Displayed only on model Nos. with CT.	—	C06: XX1X or C06: XX3X
Upper display: \bar{M} Max. PV value Lower display: \bar{m} Min. PV value	Min./max. PV values of all DMCs		—	C06: XX2X or C06: XX3X
Upper display: $\bar{5} \bar{P} \bar{n}$ Lower display: SP set value	SP set switching display	Enabled by multi-SP use on DMC10	1	C06: XX1X or C06: XX3X
Upper display: $\bar{r} \bar{E} \bar{P} \bar{n}$ Lower display: Recipe set value	Recipe set switching display	Enabled by setting C22 on SDU10	1	C06: XX2X or C06: XX3X

■ Item Descriptions

● Basic display

“— — —” is displayed on both the upper and lower displays when the SDU10 is turned ON for the first time.

As the SDU10 does not have any information on currently connected DMC10s, execute automatic detection (C27) after SDU10 setup is completed.

When the SDU10 is turned ON again after monitoring of DMC10s is enabled, the current values of the modules and channels that were last displayed are displayed.

For the PV values of currently monitored DMC10s, the PV value and PV alarm are displayed alternately if a sensor line break or other malfunction occurs.

To shift between the basic display displays in DMC10 address order (ascending order), press the  key.

● SP display

Display of SP on the upper and lower displays is enabled only when PV is set for the upper and lower displays in the basic display. Press the  key in the PV value display mode.

Set the basic display in the Run mode (C06).

To shift between the basic display displays in DMC10 address order (ascending order), press the  key.

● CT1, CT2 current value

This screen can be displayed by setting the Run mode (C06).

To shift between the CT displays in DMC10 address order (ascending order), press the  key.

If, during display, there is a DMC10 that does not support CT input, that DMC10 is skipped.

● Min./max. PV value display

This screen can be displayed by setting the Run mode (C06).

The “min./max. PV value display” is a function for simultaneously displaying the minimum and maximum values from among the PV value of all channels on all DMC10s currently connected to the SDU10.

This function can be used, for example, to check whether or not the temperature distribution width of control targets such as chambers or glass substrates that are heated at multiple locations is within predetermined values.

The current minimum and maximum values are displayed. This item can be set to hold peak values after the SDU10 is turned ON. Minimum and maximum values can be cleared either by pressing the  key or external switch inputs.

● SP set switching display

On 2-channel DMC10 models, the SP sets can be changed within the range 1 to 8, and on 4-channel models within the range 1 to 4.

● Recipe switching display

Recipes can be switched up to the value set at number of recipe sets (C22).



Note

For details on the slave functions, see “Appendix 2. USE OF AN SDU10 AS A SLAVE” (page 23).

■ Changing DMC10 Settings

Function Prompt	Item	Description	Factory Setting	Remarks
<i>SP</i> or <i>SP1</i>	SP value or SP1 value	Differs according to setting of single-/multi-SP on DMC10.	–	
<i>SP2</i>	SP2 value		–	
<i>SP3</i>	SP3 value		–	
<i>SP4</i>	SP4 value		–	
<i>SP5</i>	SP5 value		–	Displayed only on 2-channels DMC10 models.
<i>SP6</i>	SP6 value		–	
<i>SP7</i>	SP7 value		–	
<i>SP8</i>	SP8 value		–	
<i>AT</i>	Auto-tuning start/stop	Starts/stops auto-tuning of currently displayed channel.	–	
<i>P</i>	Proportional band	Changes setting of P (proportional band) of currently displayed channel.	–	
<i>I</i>	Reset time	Changes setting of I (reset time) of currently displayed channel.	–	
<i>D</i>	Rate time	Changes setting of D (rate time) of currently displayed channel.	–	
<i>CF1</i>	Number of user-defined items 1	Enabled by setting of number of user-defined items (C19)	–	C30, C50, C70 must be set.
<i>CF2</i>	Number of user-defined items 2		–	C31, C51, C71 must be set.
<i>CF3</i>	Number of user-defined items 3		–	C32, C52, C72 must be set.
<i>CF4</i>	Number of user-defined items 4		–	C33, C53, C73 must be set.
<i>CF5</i>	Number of user-defined items 5		–	C34, C54, C74 must be set.
<i>CF6</i>	Number of user-defined items 6		–	C35, C55, C75 must be set.
<i>CF7</i>	Number of user-defined items 7		–	C36, C56, C76 must be set.
<i>CF8</i>	Number of user-defined items 8		–	C37, C57, C77 must be set.
<i>CF9</i>	Number of user-defined items 9		–	C38, C58, C78 must be set.
<i>CF10</i>	Number of user-defined items10		–	C39, C59, C79 must be set.
<i>CF11</i>	Number of user-defined items 11		–	C40, C60, C80 must be set.
<i>CF12</i>	Number of user-defined items 12		–	C41, C61, C81 must be set.
<i>CF13</i>	Number of user-defined items 13		–	C42, C62, C82 must be set.
<i>CF14</i>	Number of user-defined items 14		–	C43, C63, C83 must be set.
<i>CF15</i>	Number of user-defined items 15		–	C44, C64, C84 must be set.
<i>CF16</i>	Number of user-defined items 16		–	C45, C65, C85 must be set.
<i>CF17</i>	Number of user-defined items 17		–	C46, C66, C86 must be set.
<i>CF18</i>	Number of user-defined items 18		–	C47, C67, C87 must be set.
<i>CF19</i>	Number of user-defined items 19		–	C48, C68, C88 must be set.
<i>CF20</i>	Number of user-defined items 20		–	C49, C69, C89 must be set.

■ Item Descriptions

● **SP (SP1 to 8)**

The SP is only displayed when single-SP use is set on the DMC10s.
When multi-SP use is enabled, SP1 to 8 are displayed on 2-channel DMC10 models, and SP1 to 4 are displayed on 4-channel DMC10 models.

● **AT (auto-tuning start/stop)**

This item is for starting/stopping auto-tuning on the currently displayed channel.

● **P (proportional band)**

This item is for changing the P (proportional band) setting of the currently displayed channel.

● **I (reset time)**

This item is for changing the I (reset time) setting of the currently displayed channel.

● **D (rate time)**

This item is for changing the D (rate time) setting of the currently displayed channel.

● **CF1 to CF20 (user-defined items)**

These items are enabled by setting SDU10 setup *C19*.
To use these functions, set setups *C19* and *C30 to C89*.

6. RECIPE FUNCTION

■ Introduction

On the SDU10, each of the setup parameters can be provided with up to 99 files called “recipes.” Recipes can be used to change the setup parameters (temperature setting, alarm values, control parameters, etc.) by a single batch operation on multiple DMC10 by individual model. Recipes can be switched to by the front panel keys on the SDU10, by external switch input from the SDU10, and by host communications.

■ Specifications

Max. number of recipes: 99

Max. number of parameter types/recipes: 199

Note, however, that the following restriction applies:

Number of recipes x parameter types x number of DMC10 units \leq 2860

■ Setup Procedure

● Setting the parameter type (*r1 to r199*)

Set the DMC10 parameter types to be saved to recipes. Specify the parameter type by the DMC10’s internal word address No.

● Reading and saving parameters

DMC10 internal parameter values are read to SDU10 for each recipe (1 to 99), and read parameters are saved within recipes.

! Handling Precautions

Recipe parameters can be set only when they have been read from a DMC10. To change data in recipes, change the parameters held internally on the DMC10, and read the parameters again.

■ Method of Use

Setup recipe parameters are written in a single operation to the target DMC10 by specifying the recipe No. on the keys on the front panel of the SDU10, external switch input or by communications.

Use the following formula to calculate the approximate time it takes to complete writing of recipe parameters to each DMC10:

$$\{30 \times (\text{number of parameter items per recipe}) + 40\} \times (\text{number of DMC10 units})$$

Unit: ms

! Handling Precautions

- The above figure is merely a guideline, and may increase depending on the operation circumstances of the SDU10. In particular, the communications time increases when the external switch input function is used and slave devices are used. When recipes are written by operating the keys on the front panel of the SDU10, the recipe set No. blinks during writing. For this reason, when writing recipes by external switch input or communications, measure the time it takes to write the recipes by operating the keys on the front panel of the SDU10, and use this value as reference.
- The communications time increases if wiring trouble, for example, prevents successful communications between the DMC10 and SDU10. Make sure that communications errors are not occurring.

7. HOST COMMUNICATIONS FUNCTION

The SDU10 is equipped with an RS-485 host communications function as part of the standard specification. This function allows the user to communicate with a host device such as a personal computer, PLC or Yamatake Corporation EST240Z touch panel using a program created by the user.

■ Features

- Up to 31 SDU10s can be connected to a single host device. (For the MODBUS, maximum 15 units)
 - When 16 or more DMC10s are to be used, DMC10s can be added on by using the SDU10.
 - The CMC10L (sold separately) is required when the communications specifications of the host device conforms to the RS-232C interface.
 - For details on the communications parameters of SDU10, see “Appendix 4. SDU10 COMMUNICATIONS PARAMETER TABLES” (page 26).
 - A wide range of communications commands are available to enable accessing of remote parameters by a single command. The same commands as those for the DMC10 are supported.
 - Some of the data of currently connected DMC10s is buffered. For this reason, DMC10 data can be easily accessed by accessing SDU10 internal parameters. Also, up to ten extra parameters can be buffered.
- SDU10 setups *C20* and *C90 to C99* must be set.

■ Specifications

SDU10 host communications is the same as DMC10 communications specifications except the cautions for the device address described as follows. (These are two ways of specifying the device address on the SDU10.)

For details, refer to Modular Controller DMC10 User’s Manual Description of Functions CP-UM-5143E, Chapter 10. Communications Functions.

• Example 1: When sub-addresses are not used

Features: - Common communications software from the host device is used regardless of whether or not an SDU10 is included in the configuration. 15 or fewer DMC10s are used.

Specifications: - DMC10 device addresses shall be unique.
 - The device address of the SDU10 shall be “0”.
 - The addresses of commands from the host device shall be as follows:
 Device address: Device address of DMC10
 Sub address: “00”

Note: - The addresses of commands from the host device shall be as follows. Note, however, that a multi-drop configuration such as that shown in figure below is not allowed.
 Device address: “FE”
 Sub address: “00”
 - For the MODBUS, set the DMC10 address to the device address.

• Example 2: When sub-addresses are used

Feature: - 16 or more DMC10 units can be used.
 Specifications: - The same DMC10 device address can be used on different SDU10s.
 - The addresses of commands from the host device shall be as follows:
 Device address: Address of SDU10
 Sub address: Device address of DMC10

Note: - The addresses for accessing SDU10 internal data shall be as follows:
 Device address: Address of SDU10
 Sub address: “00”
 - For the MODBUS, the one group of upper 4 bits in the device address is the SDU10 address. Another group of lower 4 bits is the DMC10 address.

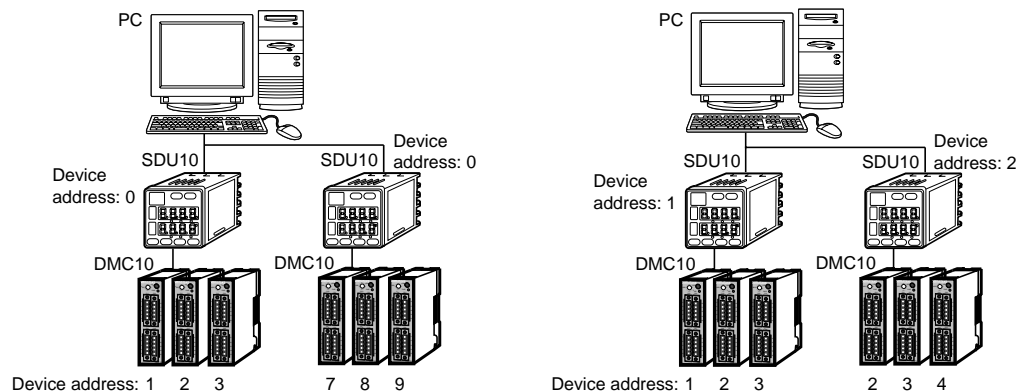

! Handling Precautions

- When accessing the DMC10 from the host device via the SDU10, pay attention to the following time-out setting condition. Accessing of SDU10 data is determined by SDU10 setup *C04*.

Condition: Set the time-out for when there is no response to at least 1s.

- Use example 1 above when using the EST240Z DMC10 package.

8. ALARM CODES

Alarms on the SDU10 can be identified by alarm lamps when an error occurs on connected DMC10s and on the SDU10.

DMC10 alarm codes can also be viewed on the upper and lower displays.

■ Alarm Lamp Indications

Lamps	State	Cause	Countermeasure	Remarks
AL1	Blinking	Display unit communications error <ul style="list-style-type: none"> • A DMC10 is not responding. • A DMC10 returns the abnormal end code. 	<ul style="list-style-type: none"> • Check for miswiring or broken communications line. • Check communications conditions. • Check for changes to DMC10 settings after automatic detection. • Slave response time is longer than time-out. (Check setup C08.) • Check additional setting items or recipe addresses. 	
	Lit	Display unit memory error <ul style="list-style-type: none"> • SDU10 memory is damaged. 	Request SDU10 repair.	
AL2	Blinking	DMC10 PV error <ul style="list-style-type: none"> • A PV-related alarm is established on a DMC10. 	<ul style="list-style-type: none"> • Operate the [CH] key to check for any DMC10s for which ALXX is alternately displayed. • Follow the description in the DMC10 User's Manual. 	For details of ALXX, see table below.
	Lit	DMC10 memory error <ul style="list-style-type: none"> • A DMC10 memory error is occurring 	<ul style="list-style-type: none"> • Operate the [CH] key to check for any DMC10s for which ALXX is alternately displayed. • Follow the description in the DMC10 User's Manual. 	For details of ALXX, see table below.

■ DMC10 Alarm Codes

Lamps	Cause	Countermeasure	Remarks
AL01	PV upper limit alarm has occurred on currently displayed DMC10 channel.	Follow the description in the DMC10 User's Manual.	
AL02	PV lower limit alarm has occurred on currently displayed DMC10 channel.		
AL03	CJ error/BC line alarm has occurred on currently displayed DMC10 channel.		
AL70	A/D alarm has occurred on currently displayed DMC10 channel.		
AL96	EEPROM error has occurred on currently displayed DMC10.		
AL97	Adjustment RAM error has occurred on currently displayed DMC10.		
AL98	Setting RAM error has occurred on currently displayed DMC10.		

■ Other Error Indications

Lamps	State	Cause	Countermeasure	Remarks
Loc	Lit for 1s	Key lock is set.	Set setup C01 to "0: Key lock not engaged."	
Err	Lit for 1s	Settings could not be written on the DMC10 Setting screen because of a communications error.	<ul style="list-style-type: none"> • When DMC10 additional setting items are being implemented, check the set addresses. • Check the DMC10 mode and other settings. 	
----	Lit	There is no display data as a communications error has occurred. (no-response/abnormal end code)	<ul style="list-style-type: none"> • Make sure that automatic detection is being executed. • Check for changes to DMC10 settings after automatic detection. • Check the DMC10 power supply. • Check for miswiring and broken lines. • Check the communications conditions of the SDU10 and DMC10. • Set a larger value to setup C08 (slave time-out) 	
...	Lit	PV value and SP value cannot be displayed.	<p>The PV and SP values are not displayed for channels that fall under the following categories:</p> <ul style="list-style-type: none"> • Channels to which the PV input type of the DMC10 is "0" • Channels that are used as RSP • Channels that are used for feeding back the motor drive 	

9. SPECIFICATIONS

Category	Item		Specifications
General Specifications	Model No.		SDU10T0100
	Memory backup		Non-volatile semiconductor memory
	Rated power supply voltage		24Vdc
	Power consumption		Max. 3W
	Insulation resistance		Across power terminal and secondary terminals: Max. 20M Ω (by 500Vdc megger)
	Dielectric strength		Across power terminal and secondary terminals: 500Vac, 1min.
	Inrush current (power ON)		Max. 10A
	Isolation		<ul style="list-style-type: none"> • Across power circuit and secondary side circuit • Across host communications and slave communications • Non-isolation across slave communications and RSW/EVENT
	Operating conditions	Ambient temperature	0 to 50°C
		Ambient humidity	10 to 90%RH
		Power voltage	21.6 to 26.4Vdc
		Vibration resistance	0 to 2m/s ²
		Impact resistance	0 to 10m/s ²
	Transport/storage conditions	Ambient temperature	-20 to +70°C
		Ambient humidity	10 to 95%RH
		Package drop	60cm
Weight		Max. 200g	
Terminal screw tightening torque		Max. 0.25N·m	
Applicable standards		EN50081-2, EN61000-6-2, IP65 equivalent	
Case material / color		PC resin / Light gray (Muncell: 2.5Y7.5/1 equivalent)	
Additional Specifications	External switch input	No. of points	8 (2 of which are shared with events)
		Functions	See SDU10 setups C11 to C18.
		Allowable ON contact resistance	Max. 250 Ω
		Allowable OFF contact resistance	Min. 100k Ω
		Allowable ON residual voltage	Max. 1V
		Open terminal voltage	5Vdc
		ON terminal current	Approx. 4mA
	Event output	No. of points	2 (shared use with external switch input)
		Functions	See SDU10 setups C09 and C10.
		Output type	Open-collector
		OFF leakage current	Max. 100 μ A
		ON output voltage	Max. 1V
		Output rating	30Vdc, Max. 70mA
	Host/slave communications	Signal level	RS-485 compliant
		Transmission path connection	Multi-point (host: max. 31 units, slave: max. 15 DMC10s)
		Communication system	Half duplex, asynchronous
		Max. line length	Max. 500m
		Terminator	External terminator must not be attached as equivalent terminating resistance is built-in.



Appendix 1. USER-DEFINED ITEM NAMES

In addition to the existing setup items, up to 20 extra items can be added on to the DMC10's setting items.

These items are set in SDU10 setups C50 to C69 (user-defined item name). (For details, see page 13.)

After a setting item has been added, it can be assigned a name (symbol) up to four character long.

The symbols can be used for the name and displayed are as follows.

Pressing the  or  keys in SDU10 setups C50 to C69 (user-defined item name) moves the selection cyclically as follows. (When a symbol stops blinking and stays lit, this indicates that the symbol has been applied.)

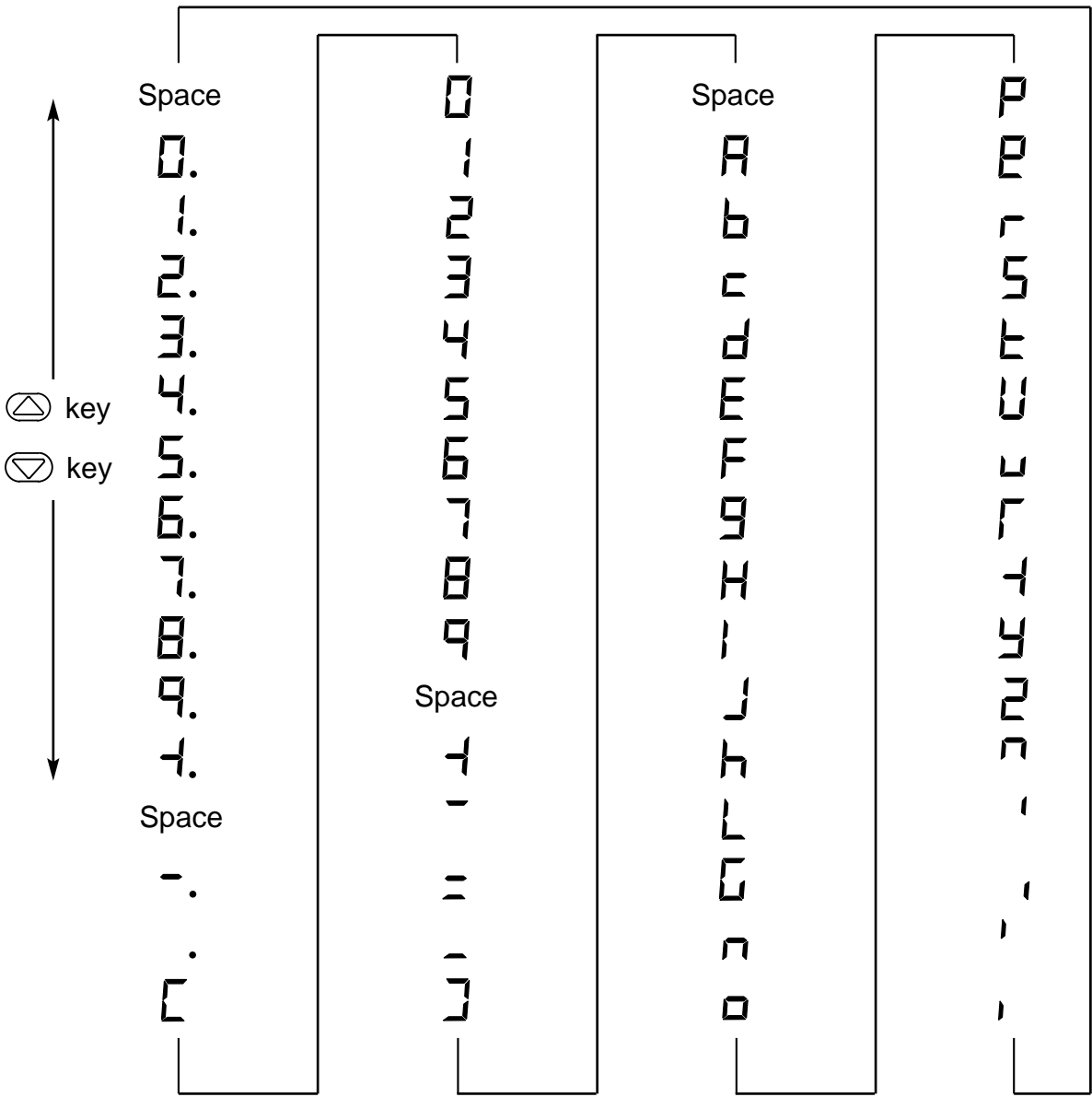

Appendix 2. USE OF AN SDU10 AS A SLAVE

■ Purpose

The PV value for up to two channels can be displayed as the SDU10 has two displays, an upper and lower display.

Adding on another SDU10 as a slave enables the PV values for four channels to be monitored simultaneously (when DMC10s on four channels are used).

The number of points can also be extended by adding on another SDU10 as a slave when there are not enough external switch inputs or event terminals.

■ Connection

Connect the SDU10 for the slave to the same line as the DMC10.

Host communications on the SDU10 for the slave is disabled.

■ Setup

Before the SDU10 is to be used as a slave, the SDU10 setup C02 must be set to "1: Slave".

■ Specifications

Items displayed on the slave are automatically matched with the items that are displayed on the master.

Only the items shown below are displayed. Other items are not displayed.

Also, DMC10 settings cannot be changed on the slave.

The external switch inputs and events provided on the slave can be used in the same way on the master.

- Basic display
- SP display
- CT display

Appendix 3. SDU10 INTERNAL SETUP DATA BATCH COPY FUNCTION

This function is for transferring all setup data from the SDU10 to another SDU10.

This function comes in useful for copying all setup data to a spare SDU10 instead of storage media for saving all SDU10 settings or setting up a new SDU10 unit.

■ Download

Perform this procedure to batch-transfer all setting data already saved on a spare SDU10 to an SDU10 newly added to the configuration.

- ① Connect the receiving SDU10 and sending SDU10 for host communications.
Note: Disable host communications on the SDU10 newly added to the configuration if host communications is already enabled.
- ② Turn ON the receiving SDU10.
- ③ Turn the sending SDU10 ON with its **CH** key held down.
If the following does not appear on the display on the sending SDU10, perform this step again.

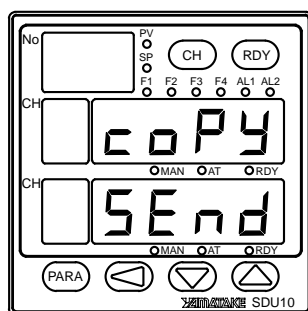

- ④ Press the **PARA** key to start the batch transfer.
During the transfer, *SEnd* blinks on the lower display on the sending SDU10, and *rEcv* is displayed on the receiving SDU10.
If the transfer ends successfully, *Fin* is lit on the lower display on the sending SDU10, and the display on the receiving SDU10 changes to the regular display.
If the transfer ends in error, *err* is lit on the lower display on the sending SDU10, and the display on the receiving SDU10 changes to the regular display.
- ⑤ When the transfer ends successfully, turn ON the receiving SDU10 again.

■ Upload

Perform this procedure to save all SDU10 setting data to a spare SDU10.

- ① Connect the receiving SDU10 and sending SDU10 for host communications.
Note: Disable host communications on the SDU10 newly added to the configuration if host communications is already enabled.
- ② Turn ON the sending SDU10.
- ③ Turn the receiving SDU10 ON with its **CH** key held down.
If the following does not appear on the display on the receiving SDU10, perform this step again.

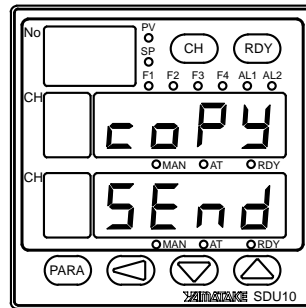

- ④ Press the **△** key to set the display as follows on the receiving SDU10.

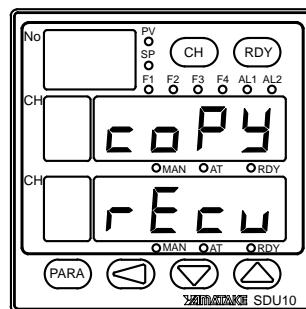

- ⑤ Press the **PARA** key to start the batch transfer.
During the transfer, *rECv* blinks on the lower display on the receiving SDU10, and *SEnd* is displayed on the sending SDU10.
If the transfer ends successfully, *Fin* is lit on the lower display on the receiving SDU10, and the display on the sending SDU10 changes to the regular display.
If the transfer ends in error, *err* is lit on the lower display on the receiving SDU10, and the display on the sending SDU10 changes to the regular display.

Appendix 4. SDU10 COMMUNICATIONS PARAMETER TABLES

■ SDU10 Setup Items

R: Read, W: Write

Function Prompt	Item	Address		RAM		ROM	
		RAM	ROM	R	W	R	W
C01	Key lock	1001	5001	○	○	○	○
C02	Slave device setting	1002	5002	○	○	○	○
C03	Device address	1003	5003	○	○	○	○
C04	Host communications settings	1004	5004	○	○	○	○
C05	Slave communications settings	1005	5005	○	○	○	○
C06	Display method in Run mode	1006	5006	○	○	○	○
C07	LED operation type	1007	5007	○	○	○	○
C08	RDY key function	1008	5008	○	○	○	○
C09	Event 1 operation type	1009	5009	○	○	○	○
C10	Event 2 operation type	1010	5010	○	○	○	○
C11	External switch input 1 operation type	1011	5011	○	○	○	○
C12	External switch input 2 operation type	1012	5012	○	○	○	○
C13	External switch input 3 operation type	1013	5013	○	○	○	○
C14	External switch input 4 operation type	1014	5014	○	○	○	○
C15	External switch input 5 operation type	1015	5015	○	○	○	○
C16	External switch input 6 operation type	1016	5016	○	○	○	○
C17	External switch input 7 operation type	1017	5017	○	○	○	○
C18	External switch input 8 operation type	1018	5018	○	○	○	○
C19	Number of user-defined items	1019	5019	○	○	○	○
C20	Number of additional buffers	1020	5020	○	○	○	○
C21	Number of recipe items	1021	5021	○	○	○	○
C22	Number of recipe sets	1022	5022	○	○	○	○
C27	Execute automatic detection	1027	5023	○	○	×	×
C28	Automatic detection results	1028	5024	○	×	×	×
C30	User-defined item 1 address	1101	5101	○	○	○	○
C31	User-defined item 2 address	1102	5102	○	○	○	○
C32	User-defined item 3 address	1103	5103	○	○	○	○
C33	User-defined item 4 address	1104	5104	○	○	○	○
C34	User-defined item 5 address	1105	5105	○	○	○	○
C35	User-defined item 6 address	1106	5106	○	○	○	○
C36	User-defined item 7 address	1107	5107	○	○	○	○
C37	User-defined item 8 address	1108	5108	○	○	○	○
C38	User-defined item 9 address	1109	5109	○	○	○	○
C39	User-defined item 10 address	1110	5110	○	○	○	○
C40	User-defined item 11 address	1111	5111	○	○	○	○
C41	User-defined item 12 address	1112	5112	○	○	○	○
C42	User-defined item 13 address	1113	5113	○	○	○	○
C43	User-defined item 14 address	1114	5114	○	○	○	○
C44	User-defined item 15 address	1115	5115	○	○	○	○
C45	User-defined item 16 address	1116	5116	○	○	○	○
C46	User-defined item 17 address	1117	5117	○	○	○	○
C47	User-defined item 18 address	1118	5118	○	○	○	○
C48	User-defined item 19 address	1119	5119	○	○	○	○
C49	User-defined item 20 address	1120	5120	○	○	○	○
C50	User-defined item 1 name	1201	5201	○	○	○	○
C51	User-defined item 2 name	1203	5203	○	○	○	○
C52	User-defined item 3 name	1205	5205	○	○	○	○

Function Prompt	Item	Address		RAM		ROM	
		RAM	ROM	R	W	R	W
C53	User-defined item 4 name	1207	5207	○	○	○	○
C54	User-defined item 5 name	1209	5209	○	○	○	○
C55	User-defined item 6 name	1211	5211	○	○	○	○
C56	User-defined item 7 name	1213	5213	○	○	○	○
C57	User-defined item 8 name	1215	5215	○	○	○	○
C58	User-defined item 9 name	1217	5217	○	○	○	○
C59	User-defined item 10 name	1219	5219	○	○	○	○
C60	User-defined item 11 name	1221	5221	○	○	○	○
C61	User-defined item 12 name	1223	5223	○	○	○	○
C62	User-defined item 13 name	1225	5225	○	○	○	○
C63	User-defined item 14 name	1227	5227	○	○	○	○
C64	User-defined item 15 name	1229	5229	○	○	○	○
C65	User-defined item 16 name	1231	5231	○	○	○	○
C66	User-defined item 17 name	1233	5233	○	○	○	○
C67	User-defined item 18 name	1235	5235	○	○	○	○
C68	User-defined item 19 name	1237	5237	○	○	○	○
C69	User-defined item 20 name	1239	5239	○	○	○	○
C70	User-defined item 1 decimal point	1301	5301	○	○	○	○
C71	User-defined item 2 decimal point	1302	5302	○	○	○	○
C72	User-defined item 3 decimal point	1303	5303	○	○	○	○
C73	User-defined item 4 decimal point	1304	5304	○	○	○	○
C74	User-defined item 5 decimal point	1305	5305	○	○	○	○
C75	User-defined item 6 decimal point	1306	5306	○	○	○	○
C76	User-defined item 7 decimal point	1307	5307	○	○	○	○
C77	User-defined item 8 decimal point	1308	5308	○	○	○	○
C78	User-defined item 9 decimal point	1309	5309	○	○	○	○
C79	User-defined item 10 decimal point	1310	5310	○	○	○	○
C80	User-defined item 11 decimal point	1311	5311	○	○	○	○
C81	User-defined item 12 decimal point	1312	5312	○	○	○	○
C82	User-defined item 13 decimal point	1313	5313	○	○	○	○
C83	User-defined item 14 decimal point	1314	5314	○	○	○	○
C84	User-defined item 15 decimal point	1315	5315	○	○	○	○
C85	User-defined item 16 decimal point	1316	5316	○	○	○	○
C86	User-defined item 17 decimal point	1317	5317	○	○	○	○
C87	User-defined item 18 decimal point	1318	5318	○	○	○	○
C88	User-defined item 19 decimal point	1319	5319	○	○	○	○
C89	User-defined item 20 decimal point	1320	5320	○	○	○	○
C90	Additional buffering address 1	1401	5401	○	○	○	○
C91	Additional buffering address 2	1402	5402	○	○	○	○
C92	Additional buffering address 3	1403	5403	○	○	○	○
C93	Additional buffering address 4	1404	5404	○	○	○	○
C94	Additional buffering address 5	1405	5405	○	○	○	○
C95	Additional buffering address 6	1406	5406	○	○	○	○
C96	Additional buffering address 7	1407	5407	○	○	○	○
C97	Additional buffering address 8	1408	5408	○	○	○	○
C98	Additional buffering address 9	1409	5409	○	○	○	○
C99	Additional buffering address 10	1410	5410	○	○	○	○

■ SDU10 Recipe Items

R: Read, W: Write

Function Prompt	Item	Address		RAM		ROM	
		RAM	ROM	R	W	R	W
r1	Recipe item 1	1501	5501	○	○	○	○
r2	Recipe item 2	1502	5502	○	○	○	○
r3	Recipe item 3	1503	5503	○	○	○	○
r4	Recipe item 4	1504	5504	○	○	○	○
r5	Recipe item 5	1505	5505	○	○	○	○
r6	Recipe item 6	1506	5506	○	○	○	○
r7	Recipe item 7	1507	5507	○	○	○	○
r8	Recipe item 8	1508	5508	○	○	○	○
r9	Recipe item 9	1509	5509	○	○	○	○
r10	Recipe item 10	1510	5510	○	○	○	○
r11	Recipe item 11	1511	5511	○	○	○	○
r12	Recipe item 12	1512	5512	○	○	○	○
r13	Recipe item 13	1513	5513	○	○	○	○
r14	Recipe item 14	1514	5514	○	○	○	○
r15	Recipe item 15	1515	5515	○	○	○	○
r16	Recipe item 16	1516	5516	○	○	○	○
r17	Recipe item 17	1517	5517	○	○	○	○
r18	Recipe item 18	1518	5518	○	○	○	○
r19	Recipe item 19	1519	5519	○	○	○	○
r20	Recipe item 20	1520	5520	○	○	○	○
r21	Recipe item 21	1521	5521	○	○	○	○
r22	Recipe item 22	1522	5522	○	○	○	○
r23	Recipe item 23	1523	5523	○	○	○	○
r24	Recipe item 24	1524	5524	○	○	○	○
r25	Recipe item 25	1525	5525	○	○	○	○
r26	Recipe item 26	1526	5526	○	○	○	○
r27	Recipe item 27	1527	5527	○	○	○	○
r28	Recipe item 28	1528	5528	○	○	○	○
r29	Recipe item 29	1529	5529	○	○	○	○
r30	Recipe item 30	1530	5530	○	○	○	○
r31	Recipe item 31	1531	5531	○	○	○	○
r32	Recipe item 32	1532	5532	○	○	○	○
r33	Recipe item 33	1533	5533	○	○	○	○
r34	Recipe item 34	1534	5534	○	○	○	○
r35	Recipe item 35	1535	5535	○	○	○	○
r36	Recipe item 36	1536	5536	○	○	○	○
r37	Recipe item 37	1537	5537	○	○	○	○
r38	Recipe item 38	1538	5538	○	○	○	○
r39	Recipe item 39	1539	5539	○	○	○	○
r40	Recipe item 40	1540	5540	○	○	○	○
r41	Recipe item 41	1541	5541	○	○	○	○
r42	Recipe item 42	1542	5542	○	○	○	○
r43	Recipe item 43	1543	5543	○	○	○	○
r44	Recipe item 44	1544	5544	○	○	○	○
r45	Recipe item 45	1545	5545	○	○	○	○
r46	Recipe item 46	1546	5546	○	○	○	○
r47	Recipe item 47	1547	5547	○	○	○	○
r48	Recipe item 48	1548	5548	○	○	○	○
r49	Recipe item 49	1549	5549	○	○	○	○
r50	Recipe item 50	1550	5550	○	○	○	○

Function Prompt	Item	Address		RAM		ROM	
		RAM	ROM	R	W	R	W
r51	Recipe item 51	1551	5551	○	○	○	○
r52	Recipe item 52	1552	5552	○	○	○	○
r53	Recipe item 53	1553	5553	○	○	○	○
r54	Recipe item 54	1554	5554	○	○	○	○
r55	Recipe item 55	1555	5555	○	○	○	○
r56	Recipe item 56	1556	5556	○	○	○	○
r57	Recipe item 57	1557	5557	○	○	○	○
r58	Recipe item 58	1558	5558	○	○	○	○
r59	Recipe item 59	1559	5559	○	○	○	○
r60	Recipe item 60	1560	5560	○	○	○	○
r61	Recipe item 61	1561	5561	○	○	○	○
r62	Recipe item 62	1562	5562	○	○	○	○
r63	Recipe item 63	1563	5563	○	○	○	○
r64	Recipe item 64	1564	5564	○	○	○	○
r65	Recipe item 65	1565	5565	○	○	○	○
r66	Recipe item 66	1566	5566	○	○	○	○
r67	Recipe item 67	1567	5567	○	○	○	○
r68	Recipe item 68	1568	5568	○	○	○	○
r69	Recipe item 69	1569	5569	○	○	○	○
r70	Recipe item 70	1570	5570	○	○	○	○
r71	Recipe item 71	1571	5571	○	○	○	○
r72	Recipe item 72	1572	5572	○	○	○	○
r73	Recipe item 73	1573	5573	○	○	○	○
r74	Recipe item 74	1574	5574	○	○	○	○
r75	Recipe item 75	1575	5575	○	○	○	○
r76	Recipe item 76	1576	5576	○	○	○	○
r77	Recipe item 77	1577	5577	○	○	○	○
r78	Recipe item 78	1578	5578	○	○	○	○
r79	Recipe item 79	1579	5579	○	○	○	○
r80	Recipe item 80	1580	5580	○	○	○	○
r81	Recipe item 81	1581	5581	○	○	○	○
r82	Recipe item 82	1582	5582	○	○	○	○
r83	Recipe item 83	1583	5583	○	○	○	○
r84	Recipe item 84	1584	5584	○	○	○	○
r85	Recipe item 85	1585	5585	○	○	○	○
r86	Recipe item 86	1586	5586	○	○	○	○
r87	Recipe item 87	1587	5587	○	○	○	○
r88	Recipe item 88	1588	5588	○	○	○	○
r89	Recipe item 89	1589	5589	○	○	○	○
r90	Recipe item 90	1590	5590	○	○	○	○
r91	Recipe item 91	1591	5591	○	○	○	○
r92	Recipe item 92	1592	5592	○	○	○	○
r93	Recipe item 93	1593	5593	○	○	○	○
r94	Recipe item 94	1594	5594	○	○	○	○
r95	Recipe item 95	1595	5595	○	○	○	○
r96	Recipe item 96	1596	5596	○	○	○	○
r97	Recipe item 97	1597	5597	○	○	○	○
r98	Recipe item 98	1598	5598	○	○	○	○
r99	Recipe item 99	1599	5599	○	○	○	○
r100	Recipe item 100	1600	5600	○	○	○	○

Function Prompt	Item	Address		RAM		ROM	
		RAM	ROM	R	W	R	W
r101	Recipe item 101	1601	5601	○	○	○	○
r102	Recipe item 102	1602	5602	○	○	○	○
r103	Recipe item 103	1603	5603	○	○	○	○
r104	Recipe item 104	1604	5604	○	○	○	○
r105	Recipe item 105	1605	5605	○	○	○	○
r106	Recipe item 106	1606	5606	○	○	○	○
r107	Recipe item 107	1607	5607	○	○	○	○
r108	Recipe item 108	1608	5608	○	○	○	○
r109	Recipe item 109	1609	5609	○	○	○	○
r110	Recipe item 110	1610	5610	○	○	○	○
r111	Recipe item 111	1611	5611	○	○	○	○
r112	Recipe item 112	1612	5612	○	○	○	○
r113	Recipe item 113	1613	5613	○	○	○	○
r114	Recipe item 114	1614	5614	○	○	○	○
r115	Recipe item 115	1615	5615	○	○	○	○
r116	Recipe item 116	1616	5616	○	○	○	○
r117	Recipe item 117	1617	5617	○	○	○	○
r118	Recipe item 118	1618	5618	○	○	○	○
r119	Recipe item 119	1619	5619	○	○	○	○
r120	Recipe item 120	1620	5620	○	○	○	○
r121	Recipe item 121	1621	5621	○	○	○	○
r122	Recipe item 122	1622	5622	○	○	○	○
r123	Recipe item 123	1623	5623	○	○	○	○
r124	Recipe item 124	1624	5624	○	○	○	○
r125	Recipe item 125	1625	5625	○	○	○	○
r126	Recipe item 126	1626	5626	○	○	○	○
r127	Recipe item 127	1627	5627	○	○	○	○
r128	Recipe item 128	1628	5628	○	○	○	○
r129	Recipe item 129	1629	5629	○	○	○	○
r130	Recipe item 130	1630	5630	○	○	○	○
r131	Recipe item 131	1631	5631	○	○	○	○
r132	Recipe item 132	1632	5632	○	○	○	○
r133	Recipe item 133	1633	5633	○	○	○	○
r134	Recipe item 134	1634	5634	○	○	○	○
r135	Recipe item 135	1635	5635	○	○	○	○
r136	Recipe item 136	1636	5636	○	○	○	○
r137	Recipe item 137	1637	5637	○	○	○	○
r138	Recipe item 138	1638	5638	○	○	○	○
r139	Recipe item 139	1639	5639	○	○	○	○
r140	Recipe item 140	1640	5640	○	○	○	○
r141	Recipe item 141	1641	5641	○	○	○	○
r142	Recipe item 142	1642	5642	○	○	○	○
r143	Recipe item 143	1643	5643	○	○	○	○
r144	Recipe item 144	1644	5644	○	○	○	○
r145	Recipe item 145	1645	5645	○	○	○	○
r146	Recipe item 146	1646	5646	○	○	○	○
r147	Recipe item 147	1647	5647	○	○	○	○
r148	Recipe item 148	1648	5648	○	○	○	○
r149	Recipe item 149	1649	5649	○	○	○	○
r150	Recipe item 150	1650	5650	○	○	○	○

Function Prompt	Item	Address		RAM		ROM	
		RAM	ROM	R	W	R	W
r151	Recipe item 151	1651	5651	○	○	○	○
r152	Recipe item 152	1652	5652	○	○	○	○
r153	Recipe item 153	1653	5653	○	○	○	○
r154	Recipe item 154	1654	5654	○	○	○	○
r155	Recipe item 155	1655	5655	○	○	○	○
r156	Recipe item 156	1656	5656	○	○	○	○
r157	Recipe item 157	1657	5657	○	○	○	○
r158	Recipe item 158	1658	5658	○	○	○	○
r159	Recipe item 159	1659	5659	○	○	○	○
r160	Recipe item 160	1660	5660	○	○	○	○
r161	Recipe item 161	1661	5661	○	○	○	○
r162	Recipe item 162	1662	5662	○	○	○	○
r163	Recipe item 163	1663	5663	○	○	○	○
r164	Recipe item 164	1664	5664	○	○	○	○
r165	Recipe item 165	1665	5665	○	○	○	○
r166	Recipe item 166	1666	5666	○	○	○	○
r167	Recipe item 167	1667	5667	○	○	○	○
r168	Recipe item 168	1668	5668	○	○	○	○
r169	Recipe item 169	1669	5669	○	○	○	○
r170	Recipe item 170	1670	5670	○	○	○	○
r171	Recipe item 171	1671	5671	○	○	○	○
r172	Recipe item 172	1672	5672	○	○	○	○
r173	Recipe item 173	1673	5673	○	○	○	○
r174	Recipe item 174	1674	5674	○	○	○	○
r175	Recipe item 175	1675	5675	○	○	○	○
r176	Recipe item 176	1676	5676	○	○	○	○
r177	Recipe item 177	1677	5677	○	○	○	○
r178	Recipe item 178	1678	5678	○	○	○	○
r179	Recipe item 179	1679	5679	○	○	○	○
r180	Recipe item 180	1680	5680	○	○	○	○
r181	Recipe item 181	1681	5681	○	○	○	○
r182	Recipe item 182	1682	5682	○	○	○	○
r183	Recipe item 183	1683	5683	○	○	○	○
r184	Recipe item 184	1684	5684	○	○	○	○
r185	Recipe item 185	1685	5685	○	○	○	○
r186	Recipe item 186	1686	5686	○	○	○	○
r187	Recipe item 187	1687	5687	○	○	○	○
r188	Recipe item 188	1688	5688	○	○	○	○
r189	Recipe item 189	1689	5689	○	○	○	○
r190	Recipe item 190	1690	5690	○	○	○	○
r191	Recipe item 191	1691	5691	○	○	○	○
r192	Recipe item 192	1692	5692	○	○	○	○
r193	Recipe item 193	1693	5693	○	○	○	○
r194	Recipe item 194	1694	5694	○	○	○	○
r195	Recipe item 195	1695	5695	○	○	○	○
r196	Recipe item 196	1696	5696	○	○	○	○
r197	Recipe item 197	1697	5697	○	○	○	○
r198	Recipe item 198	1698	5698	○	○	○	○
r199	Recipe item 199	1699	5699	○	○	○	○

■ SDU10 Recipe Sets

R: Read, W: Write

Function Prompt	Item	Address		RAM		ROM	
		RAM	ROM	R	W	R	W
rf1	Recipe set 1	1701	5701	○	○	○	○
rf2	Recipe set 2	1702	5702	○	○	○	○
rf3	Recipe set 3	1703	5703	○	○	○	○
rf4	Recipe set 4	1704	5704	○	○	○	○
rf5	Recipe set 5	1705	5705	○	○	○	○
rf6	Recipe set 6	1706	5706	○	○	○	○
rf7	Recipe set 7	1707	5707	○	○	○	○
rf8	Recipe set 8	1708	5708	○	○	○	○
rf9	Recipe set 9	1709	5709	○	○	○	○
rf10	Recipe set 10	1710	5710	○	○	○	○
rf11	Recipe set 11	1711	5711	○	○	○	○
rf12	Recipe set 12	1712	5712	○	○	○	○
rf13	Recipe set 13	1713	5713	○	○	○	○
rf14	Recipe set 14	1714	5714	○	○	○	○
rf15	Recipe set 15	1715	5715	○	○	○	○
rf16	Recipe set 16	1716	5716	○	○	○	○
rf17	Recipe set 17	1717	5717	○	○	○	○
rf18	Recipe set 18	1718	5718	○	○	○	○
rf19	Recipe set 19	1719	5719	○	○	○	○
rf20	Recipe set 20	1720	5720	○	○	○	○
rf21	Recipe set 21	1721	5721	○	○	○	○
rf22	Recipe set 22	1722	5722	○	○	○	○
rf23	Recipe set 23	1723	5723	○	○	○	○
rf24	Recipe set 24	1724	5724	○	○	○	○
rf25	Recipe set 25	1725	5725	○	○	○	○
rf26	Recipe set 26	1726	5726	○	○	○	○
rf27	Recipe set 27	1727	5727	○	○	○	○
rf28	Recipe set 28	1728	5728	○	○	○	○
rf29	Recipe set 29	1729	5729	○	○	○	○
rf30	Recipe set 30	1730	5730	○	○	○	○
rf31	Recipe set 31	1731	5731	○	○	○	○
rf32	Recipe set 32	1732	5732	○	○	○	○
rf33	Recipe set 33	1733	5733	○	○	○	○
rf34	Recipe set 34	1734	5734	○	○	○	○
rf35	Recipe set 35	1735	5735	○	○	○	○
rf36	Recipe set 36	1736	5736	○	○	○	○
rf37	Recipe set 37	1737	5737	○	○	○	○
rf38	Recipe set 38	1738	5738	○	○	○	○
rf39	Recipe set 39	1739	5739	○	○	○	○
rf40	Recipe set 40	1740	5740	○	○	○	○
rf41	Recipe set 41	1741	5741	○	○	○	○
rf42	Recipe set 42	1742	5742	○	○	○	○
rf43	Recipe set 43	1743	5743	○	○	○	○
rf44	Recipe set 44	1744	5744	○	○	○	○
rf45	Recipe set 45	1745	5745	○	○	○	○
rf46	Recipe set 46	1746	5746	○	○	○	○
rf47	Recipe set 47	1747	5747	○	○	○	○
rf48	Recipe set 48	1748	5748	○	○	○	○
rf49	Recipe set 49	1749	5749	○	○	○	○
rf50	Recipe set 50	1750	5750	○	○	○	○

Function Prompt	Item	Address		RAM		ROM	
		RAM	ROM	R	W	R	W
rf51	Recipe set 51	1751	5751	○	○	○	○
rf52	Recipe set 52	1752	5752	○	○	○	○
rf53	Recipe set 53	1753	5753	○	○	○	○
rf54	Recipe set 54	1754	5754	○	○	○	○
rf55	Recipe set 55	1755	5755	○	○	○	○
rf56	Recipe set 56	1756	5756	○	○	○	○
rf57	Recipe set 57	1757	5757	○	○	○	○
rf58	Recipe set 58	1758	5758	○	○	○	○
rf59	Recipe set 59	1759	5759	○	○	○	○
rf60	Recipe set 60	1760	5760	○	○	○	○
rf61	Recipe set 61	1761	5761	○	○	○	○
rf62	Recipe set 62	1762	5762	○	○	○	○
rf63	Recipe set 63	1763	5763	○	○	○	○
rf64	Recipe set 64	1764	5764	○	○	○	○
rf65	Recipe set 65	1765	5765	○	○	○	○
rf66	Recipe set 66	1766	5766	○	○	○	○
rf67	Recipe set 67	1767	5767	○	○	○	○
rf68	Recipe set 68	1768	5768	○	○	○	○
rf69	Recipe set 69	1769	5769	○	○	○	○
rf70	Recipe set 70	1770	5770	○	○	○	○
rf71	Recipe set 71	1771	5771	○	○	○	○
rf72	Recipe set 72	1772	5772	○	○	○	○
rf73	Recipe set 73	1773	5773	○	○	○	○
rf74	Recipe set 74	1774	5774	○	○	○	○
rf75	Recipe set 75	1775	5775	○	○	○	○
rf76	Recipe set 76	1776	5776	○	○	○	○
rf77	Recipe set 77	1777	5777	○	○	○	○
rf78	Recipe set 78	1778	5778	○	○	○	○
rf79	Recipe set 79	1779	5779	○	○	○	○
rf80	Recipe set 80	1780	5780	○	○	○	○
rf81	Recipe set 81	1781	5781	○	○	○	○
rf82	Recipe set 82	1782	5782	○	○	○	○
rf83	Recipe set 83	1783	5783	○	○	○	○
rf84	Recipe set 84	1784	5784	○	○	○	○
rf85	Recipe set 85	1785	5785	○	○	○	○
rf86	Recipe set 86	1786	5786	○	○	○	○
rf87	Recipe set 87	1787	5787	○	○	○	○
rf88	Recipe set 88	1788	5788	○	○	○	○
rf89	Recipe set 89	1789	5789	○	○	○	○
rf90	Recipe set 90	1790	5790	○	○	○	○
rf91	Recipe set 91	1791	5791	○	○	○	○
rf92	Recipe set 92	1792	5792	○	○	○	○
rf93	Recipe set 93	1793	5793	○	○	○	○
rf94	Recipe set 94	1794	5794	○	○	○	○
rf95	Recipe set 95	1795	5795	○	○	○	○
rf96	Recipe set 96	1796	5796	○	○	○	○
rf97	Recipe set 97	1797	5797	○	○	○	○
rf98	Recipe set 98	1798	5798	○	○	○	○
rf99	Recipe set 99	1799	5799	○	○	○	○

■ State Monitoring Data

R: Read, W: Write

DMC10	Item	Address		RAM		ROM	
		RAM	ROM	R	W	R	W
	SDU alarm monitor	1801	----	○	×	×	×
	DMC communications state	1802	----	○	×	×	×

* SDU alarm monitor (1801W)

Bit	Item	Value	Remarks
Bit 0	Reserved	0 at all times	
Bit 1	EEPROM checksum error	At error = 1	
Bit 2	Reserved	0 at all times	
Bit 3	Reserved	0 at all times	
Bit 4	Reserved	0 at all times	
Bit 5	Reserved	0 at all times	
Bit 6	Reserved	0 at all times	
Bit 7	Reserved	0 at all times	
Bit 8	Alarm lamp 1 information 1	Blinking = 1	
Bit 9	Alarm lamp 1 information 2	Lit, blinking = 1	
Bit 10	Alarm lamp 2 information 1	Blinking = 1	
Bit 11	Alarm lamp 2 information 2	Lit, blinking = 1	
Bit 12	Reserved	0 at all times	
Bit 13	Reserved	0 at all times	
Bit 14	Reserved	0 at all times	
Bit 15	Reserved	0 at all times	

* DMC communications state (1802W)

Bit	Item	Value	Remarks
Bit 0	Reserved	0 at all times	
Bit 1	Device address 1DMC	At no-response = 1	
Bit 2	Device address 2DMC	At no-response = 1	
Bit 3	Device address 3DMC	At no-response = 1	
Bit 4	Device address 4DMC	At no-response = 1	
Bit 5	Device address 5DMC	At no-response = 1	
Bit 6	Device address 6DMC	At no-response = 1	
Bit 7	Device address 7DMC	At no-response = 1	
Bit 8	Device address 8DMC	At no-response = 1	
Bit 9	Device address 9DMC	At no-response = 1	
Bit 10	Device address 10DMC	At no-response = 1	
Bit 11	Device address 11DMC	At no-response = 1	
Bit 12	Device address 12DMC	At no-response = 1	
Bit 13	Device address 13DMC	At no-response = 1	
Bit 14	Device address 14DMC	At no-response = 1	
Bit 15	Device address 15DMC	At no-response = 1	

■ DMC10 Buffering Data

Nos. 1, 2, 3 and so on are temporary numbers assigned to currently connected DMC10s that are resorted in ascending order as a result of automatic detection. These Nos. are not the device address of detected DCM10s.

R: Read, W: Write

DMC10	Item	Address		RAM		ROM	
		RAM	ROM	R	W	R	W
No.1	PV value CH1	1901	----	○	×	×	×
	PV value CH2	1902	----	○	×	×	×
	PV value CH3	1903	----	○	×	×	×
	PV value CH4	1904	----	○	×	×	×
	SP value CH1	1905	----	○	×	×	×
	SP value CH2	1906	----	○	×	×	×
	SP value CH3	1907	----	○	×	×	×
	SP value CH4	1908	----	○	×	×	×
	CT value CH1	1909	----	○	×	×	×
	CT value CH2	1910	----	○	×	×	×
	All alarm representative	1911	----	○	×	×	×
	PV alarm details	1912	----	○	×	×	×
	Control-related information *1	1913	----	○	×	×	×
	Results of internal operation on event output/external switch input	1914	----	○	×	×	×
	External switch input state	1915	----	○	×	×	×
	Event output/control output state	1916	----	○	×	×	×
	Communications DI *2	1917	----	○	×	×	×
	Control-related status	1918	----	○	×	×	×
	Additional buffering data 1	1919	----	○	×	×	×
	Additional buffering data 2	1920	----	○	×	×	×
	Additional buffering data 3	1921	----	○	×	×	×
	Additional buffering data 4	1922	----	○	×	×	×
	Additional buffering data 5	1923	----	○	×	×	×
	Additional buffering data 6	1924	----	○	×	×	×
	Additional buffering data 7	1925	----	○	×	×	×
	Additional buffering data 8	1926	----	○	×	×	×
	Additional buffering data 9	1927	----	○	×	×	×
	Additional buffering data 10	1928	----	○	×	×	×
No.2	PV value CH1	1929	----	○	×	×	×
	PV value CH2	1930	----	○	×	×	×
	PV value CH3	1931	----	○	×	×	×
	PV value CH4	1932	----	○	×	×	×
	SP value CH1	1933	----	○	×	×	×
	SP value CH2	1934	----	○	×	×	×
	SP value CH3	1935	----	○	×	×	×
	SP value CH4	1936	----	○	×	×	×
	CT value CH	1937	----	○	×	×	×
	CT value CH2	1938	----	○	×	×	×
	All alarm representative	1939	----	○	×	×	×
	PV alarm details	1940	----	○	×	×	×
	Control-related information *1	1941	----	○	×	×	×
	Results of internal operation on event output/external switch input	1942	----	○	×	×	×
	External switch input state	1943	----	○	×	×	×
	Event output/control output state	1944	----	○	×	×	×
	Communications DI *2	1945	----	○	×	×	×
	Control-related status	1946	----	○	×	×	×
	Additional buffering data 1	1947	----	○	×	×	×
	Additional buffering data 2	1948	----	○	×	×	×
	Additional buffering data 3	1949	----	○	×	×	×
	Additional buffering data 4	1950	----	○	×	×	×
	Additional buffering data 5	1951	----	○	×	×	×
	Additional buffering data 6	1952	----	○	×	×	×
	Additional buffering data 7	1953	----	○	×	×	×
	Additional buffering data 8	1954	----	○	×	×	×
	Additional buffering data 9	1955	----	○	×	×	×
	Additional buffering data 10	1956	----	○	×	×	×

DMC10	Item	Address		RAM		ROM	
		RAM	ROM	R	W	R	W
No.3	PV value CH1	1957	----	○	×	×	×
	PV value CH2	1958	----	○	×	×	×
	PV value CH3	1959	----	○	×	×	×
	PV value CH4	1960	----	○	×	×	×
	SP value CH1	1961	----	○	×	×	×
	SP value CH2	1962	----	○	×	×	×
	SP value CH3	1963	----	○	×	×	×
	SP value CH4	1964	----	○	×	×	×
	CT value CH1	1965	----	○	×	×	×
	CT value CH2	1966	----	○	×	×	×
	All alarm representative	1967	----	○	×	×	×
	PV alarm details	1968	----	○	×	×	×
	Control-related information *1	1969	----	○	×	×	×
	Results of internal operation on event output/external switch input	1970	----	○	×	×	×
	External switch input state	1971	----	○	×	×	×
	Event output/control output state	1972	----	○	×	×	×
	Communications DI *2	1973	----	○	×	×	×
	Control-related status	1974	----	○	×	×	×
	Additional buffering data 1	1975	----	○	×	×	×
	Additional buffering data 2	1976	----	○	×	×	×
	Additional buffering data 3	1977	----	○	×	×	×
	Additional buffering data 4	1978	----	○	×	×	×
	Additional buffering data 5	1979	----	○	×	×	×
	Additional buffering data 6	1980	----	○	×	×	×
	Additional buffering data 7	1981	----	○	×	×	×
	Additional buffering data 8	1982	----	○	×	×	×
	Additional buffering data 9	1983	----	○	×	×	×
	Additional buffering data 10	1984	----	○	×	×	×
No.4	PV value CH1	1985	----	○	×	×	×
	PV value CH2	1986	----	○	×	×	×
	PV value CH3	1987	----	○	×	×	×
	PV value CH4	1988	----	○	×	×	×
	SP value CH1	1989	----	○	×	×	×
	SP value CH2	1990	----	○	×	×	×
	SP value CH3	1991	----	○	×	×	×
	SP value CH4	1992	----	○	×	×	×
	CT value CH1	1993	----	○	×	×	×
	CT value CH2	1994	----	○	×	×	×
	All alarm representative	1995	----	○	×	×	×
	PV alarm details	1996	----	○	×	×	×
	Control-related information *1	1997	----	○	×	×	×
	Results of internal operation on event output/external switch input	1998	----	○	×	×	×
	External switch input state	1999	----	○	×	×	×
	Event output/control output state	2000	----	○	×	×	×
	Communications DI *2	2001	----	○	×	×	×
	Control-related status	2002	----	○	×	×	×
	Additional buffering data 1	2003	----	○	×	×	×
	Additional buffering data 2	2004	----	○	×	×	×
	Additional buffering data 3	2005	----	○	×	×	×
	Additional buffering data 4	2006	----	○	×	×	×
	Additional buffering data 5	2007	----	○	×	×	×
	Additional buffering data 6	2008	----	○	×	×	×
	Additional buffering data 7	2009	----	○	×	×	×
	Additional buffering data 8	2010	----	○	×	×	×
	Additional buffering data 9	2011	----	○	×	×	×
	Additional buffering data 10	2012	----	○	×	×	×

*1, 2: For details on control-related information and communications DI, see page 35.

DMC10	Item	Address		RAM		ROM	
		RAM	ROM	R	W	R	W
No.5	PV value CH1	2013	----	○	×	×	×
	PV value CH2	2014	----	○	×	×	×
	PV value CH3	2015	----	○	×	×	×
	PV value CH4	2016	----	○	×	×	×
	SP value CH1	2017	----	○	×	×	×
	SP value CH2	2018	----	○	×	×	×
	SP value CH3	2019	----	○	×	×	×
	SP value CH4	2020	----	○	×	×	×
	CT value CH1	2021	----	○	×	×	×
	CT value CH2	2022	----	○	×	×	×
	All alarm representative	2023	----	○	×	×	×
	PV alarm details	2024	----	○	×	×	×
	Control-related information *1	2025	----	○	×	×	×
	Results of internal operation on event output/external switch input	2026	----	○	×	×	×
	External switch input state	2027	----	○	×	×	×
	Event output/control output state	2028	----	○	×	×	×
	Communications DI *2	2029	----	○	×	×	×
	Control-related status	2030	----	○	×	×	×
	Additional buffering data 1	2031	----	○	×	×	×
	Additional buffering data 2	2032	----	○	×	×	×
Additional buffering data 3	2033	----	○	×	×	×	
Additional buffering data 4	2034	----	○	×	×	×	
Additional buffering data 5	2035	----	○	×	×	×	
Additional buffering data 6	2036	----	○	×	×	×	
Additional buffering data 7	2037	----	○	×	×	×	
Additional buffering data 8	2038	----	○	×	×	×	
Additional buffering data 9	2039	----	○	×	×	×	
Additional buffering data 10	2040	----	○	×	×	×	
No.6	PV value CH1	2041	----	○	×	×	×
	PV value CH2	2042	----	○	×	×	×
	PV value CH3	2043	----	○	×	×	×
	PV value CH4	2044	----	○	×	×	×
	SP value CH1	2045	----	○	×	×	×
	SP value CH2	2046	----	○	×	×	×
	SP value CH3	2047	----	○	×	×	×
	SP value CH4	2048	----	○	×	×	×
	CT value CH1	2049	----	○	×	×	×
	CT value CH2	2050	----	○	×	×	×
	All alarm representative	2051	----	○	×	×	×
	PV alarm details	2052	----	○	×	×	×
	Control-related information *1	2053	----	○	×	×	×
	Results of internal operation on event output/external switch input	2054	----	○	×	×	×
	External switch input state	2055	----	○	×	×	×
	Event output/control output state	2056	----	○	×	×	×
	Communications DI *2	2057	----	○	×	×	×
	Control-related status	2058	----	○	×	×	×
	Additional buffering data 1	2059	----	○	×	×	×
	Additional buffering data 2	2060	----	○	×	×	×
Additional buffering data 3	2061	----	○	×	×	×	
Additional buffering data 4	2062	----	○	×	×	×	
Additional buffering data 5	2063	----	○	×	×	×	
Additional buffering data 6	2064	----	○	×	×	×	
Additional buffering data 7	2065	----	○	×	×	×	
Additional buffering data 8	2066	----	○	×	×	×	
Additional buffering data 9	2067	----	○	×	×	×	
Additional buffering data 10	2068	----	○	×	×	×	

DMC10	Item	Address		RAM		ROM	
		RAM	ROM	R	W	R	W
No.7	PV value CH1	2069	----	○	×	×	×
	PV value CH2	2070	----	○	×	×	×
	PV value CH3	2071	----	○	×	×	×
	PV value CH4	2072	----	○	×	×	×
	SP value CH1	2073	----	○	×	×	×
	SP value CH2	2074	----	○	×	×	×
	SP value CH3	2075	----	○	×	×	×
	SP value CH4	2076	----	○	×	×	×
	CT value CH1	2077	----	○	×	×	×
	CT value CH2	2078	----	○	×	×	×
	All alarm representative	2079	----	○	×	×	×
	PV alarm details	2080	----	○	×	×	×
	Control-related information *1	2081	----	○	×	×	×
	Results of internal operation on event output/external switch input	2082	----	○	×	×	×
	External switch input state	2083	----	○	×	×	×
	Event output/control output state	2084	----	○	×	×	×
	Communications DI *2	2085	----	○	×	×	×
	Control-related status	2086	----	○	×	×	×
	Additional buffering data 1	2087	----	○	×	×	×
	Additional buffering data 2	2088	----	○	×	×	×
Additional buffering data 3	2089	----	○	×	×	×	
Additional buffering data 4	2090	----	○	×	×	×	
Additional buffering data 5	2091	----	○	×	×	×	
Additional buffering data 6	2092	----	○	×	×	×	
Additional buffering data 7	2093	----	○	×	×	×	
Additional buffering data 8	2094	----	○	×	×	×	
Additional buffering data 9	2095	----	○	×	×	×	
Additional buffering data 10	2096	----	○	×	×	×	
No.8	PV value CH1	2097	----	○	×	×	×
	PV value CH2	2098	----	○	×	×	×
	PV value CH3	2099	----	○	×	×	×
	PV value CH4	2100	----	○	×	×	×
	SP value CH1	2101	----	○	×	×	×
	SP value CH2	2102	----	○	×	×	×
	SP value CH3	2103	----	○	×	×	×
	SP value CH4	2104	----	○	×	×	×
	CT value CH1	2105	----	○	×	×	×
	CT value CH2	2106	----	○	×	×	×
	All alarm representative	2107	----	○	×	×	×
	PV alarm details	2108	----	○	×	×	×
	Control-related information *1	2109	----	○	×	×	×
	Results of internal operation on event output/external switch input	2110	----	○	×	×	×
	External switch input state	2111	----	○	×	×	×
	Event output/control output state	2112	----	○	×	×	×
	Communications DI *2	2113	----	○	×	×	×
	Control-related status	2114	----	○	×	×	×
	Additional buffering data 1	2115	----	○	×	×	×
	Additional buffering data 2	2116	----	○	×	×	×
Additional buffering data 3	2117	----	○	×	×	×	
Additional buffering data 4	2118	----	○	×	×	×	
Additional buffering data 5	2119	----	○	×	×	×	
Additional buffering data 6	2120	----	○	×	×	×	
Additional buffering data 7	2121	----	○	×	×	×	
Additional buffering data 8	2122	----	○	×	×	×	
Additional buffering data 9	2123	----	○	×	×	×	
Additional buffering data 10	2124	----	○	×	×	×	

*1, 2: For details on control-related information and communications DI, see page 35.

DMC10	Item	Address		RAM		ROM	
		RAM	ROM	R	W	R	W
No.9	PV value CH1	2125	----	○	×	×	×
	PV value CH2	2126	----	○	×	×	×
	PV value CH3	2127	----	○	×	×	×
	PV value CH4	2128	----	○	×	×	×
	SP value CH1	2129	----	○	×	×	×
	SP value CH2	2130	----	○	×	×	×
	SP value CH3	2131	----	○	×	×	×
	SP value CH4	2132	----	○	×	×	×
	CT value CH1	2133	----	○	×	×	×
	CT value CH2	2134	----	○	×	×	×
	All alarm representative	2135	----	○	×	×	×
	PV alarm details	2136	----	○	×	×	×
	Control-related information *1	2137	----	○	×	×	×
	Results of internal operation on event output/external switch input	2138	----	○	×	×	×
	External switch input state	2139	----	○	×	×	×
	Event output/control output state	2140	----	○	×	×	×
	Communications DI *2	2141	----	○	×	×	×
	Control-related status	2142	----	○	×	×	×
	Additional buffering data 1	2143	----	○	×	×	×
	Additional buffering data 2	2144	----	○	×	×	×
	Additional buffering data 3	2145	----	○	×	×	×
	Additional buffering data 4	2146	----	○	×	×	×
Additional buffering data 5	2147	----	○	×	×	×	
Additional buffering data 6	2148	----	○	×	×	×	
Additional buffering data 7	2149	----	○	×	×	×	
Additional buffering data 8	2150	----	○	×	×	×	
Additional buffering data 9	2151	----	○	×	×	×	
Additional buffering data 10	2152	----	○	×	×	×	
No.10	PV value CH1	2153	----	○	×	×	×
	PV value CH2	2154	----	○	×	×	×
	PV value CH3	2155	----	○	×	×	×
	PV value CH4	2156	----	○	×	×	×
	SP value CH1	2157	----	○	×	×	×
	SP value CH2	2158	----	○	×	×	×
	SP value CH3	2159	----	○	×	×	×
	SP value CH4	2160	----	○	×	×	×
	CT value CH1	2161	----	○	×	×	×
	CT value CH2	2162	----	○	×	×	×
	All alarm representative	2163	----	○	×	×	×
	PV alarm details	2164	----	○	×	×	×
	Control-related information *1	2165	----	○	×	×	×
	Results of internal operation on event output/external switch input	2166	----	○	×	×	×
	External switch input state	2167	----	○	×	×	×
	Event output/control output state	2168	----	○	×	×	×
	Communications DI *2	2169	----	○	×	×	×
	Control-related status	2170	----	○	×	×	×
	Additional buffering data 1	2171	----	○	×	×	×
	Additional buffering data 2	2172	----	○	×	×	×
	Additional buffering data 3	2173	----	○	×	×	×
	Additional buffering data 4	2174	----	○	×	×	×
Additional buffering data 5	2175	----	○	×	×	×	
Additional buffering data 6	2176	----	○	×	×	×	
Additional buffering data 7	2177	----	○	×	×	×	
Additional buffering data 8	2178	----	○	×	×	×	
Additional buffering data 9	2179	----	○	×	×	×	
Additional buffering data 10	2180	----	○	×	×	×	

DMC10	Item	Address		RAM		ROM	
		RAM	ROM	R	W	R	W
No.11	PV value CH1	2181	----	○	×	×	×
	PV value CH2	2182	----	○	×	×	×
	PV value CH3	2183	----	○	×	×	×
	PV value CH4	2184	----	○	×	×	×
	SP value CH1	2185	----	○	×	×	×
	SP value CH2	2186	----	○	×	×	×
	SP value CH3	2187	----	○	×	×	×
	SP value CH4	2188	----	○	×	×	×
	CT value CH1	2189	----	○	×	×	×
	CT value CH2	2190	----	○	×	×	×
	All alarm representative	2191	----	○	×	×	×
	PV alarm details	2192	----	○	×	×	×
	Control-related information *1	2193	----	○	×	×	×
	Results of internal operation on event output/external switch input	2194	----	○	×	×	×
	External switch input state	2195	----	○	×	×	×
	Event output/control output state	2196	----	○	×	×	×
	Communications DI *2	2197	----	○	×	×	×
	Control-related status	2198	----	○	×	×	×
	Additional buffering data 1	2199	----	○	×	×	×
	Additional buffering data 2	2200	----	○	×	×	×
	Additional buffering data 3	2201	----	○	×	×	×
	Additional buffering data 4	2202	----	○	×	×	×
Additional buffering data 5	2203	----	○	×	×	×	
Additional buffering data 6	2204	----	○	×	×	×	
Additional buffering data 7	2205	----	○	×	×	×	
Additional buffering data 8	2206	----	○	×	×	×	
Additional buffering data 9	2207	----	○	×	×	×	
Additional buffering data 10	2208	----	○	×	×	×	
No.12	PV value CH1	2209	----	○	×	×	×
	PV value CH2	2210	----	○	×	×	×
	PV value CH3	2211	----	○	×	×	×
	PV value CH4	2212	----	○	×	×	×
	SP value CH1	2213	----	○	×	×	×
	SP value CH2	2214	----	○	×	×	×
	SP value CH3	2215	----	○	×	×	×
	SP value CH4	2216	----	○	×	×	×
	CT value CH1	2217	----	○	×	×	×
	CT value CH2	2218	----	○	×	×	×
	All alarm representative	2219	----	○	×	×	×
	PV alarm details	2220	----	○	×	×	×
	Control-related information *1	2221	----	○	×	×	×
	Results of internal operation on event output/external switch input	2222	----	○	×	×	×
	External switch input state	2223	----	○	×	×	×
	Event output/control output state	2224	----	○	×	×	×
	Communications DI *2	2225	----	○	×	×	×
	Control-related status	2226	----	○	×	×	×
	Additional buffering data 1	2227	----	○	×	×	×
	Additional buffering data 2	2228	----	○	×	×	×
	Additional buffering data 3	2229	----	○	×	×	×
	Additional buffering data 4	2230	----	○	×	×	×
Additional buffering data 5	2231	----	○	×	×	×	
Additional buffering data 6	2232	----	○	×	×	×	
Additional buffering data 7	2233	----	○	×	×	×	
Additional buffering data 8	2234	----	○	×	×	×	
Additional buffering data 9	2235	----	○	×	×	×	
Additional buffering data 10	2236	----	○	×	×	×	

*1, 2: For details on control-related information and communications DI, see page 35.

DMC10	Item	Address		RAM		ROM	
		RAM	ROM	R	W	R	W
No.13	PV value CH1	2237	----	○	×	×	×
	PV value CH2	2238	----	○	×	×	×
	PV value CH3	2239	----	○	×	×	×
	PV value CH4	2240	----	○	×	×	×
	SP value CH1	2241	----	○	×	×	×
	SP value CH2	2242	----	○	×	×	×
	SP value CH3	2243	----	○	×	×	×
	SP value CH4	2244	----	○	×	×	×
	CT value CH1	2245	----	○	×	×	×
	CT value CH2	2246	----	○	×	×	×
	All alarm representative	2247	----	○	×	×	×
	PV alarm details	2248	----	○	×	×	×
	Control-related information *1	2249	----	○	×	×	×
	Results of internal operation on event output/external switch input	2250	----	○	×	×	×
	External switch input state	2251	----	○	×	×	×
	Event output/control output state	2252	----	○	×	×	×
	Communications DI *2	2253	----	○	×	×	×
	Control-related status	2254	----	○	×	×	×
	Additional buffering data 1	2255	----	○	×	×	×
	Additional buffering data 2	2256	----	○	×	×	×
	Additional buffering data 3	2257	----	○	×	×	×
	Additional buffering data 4	2258	----	○	×	×	×
	Additional buffering data 5	2259	----	○	×	×	×
	Additional buffering data 6	2260	----	○	×	×	×
Additional buffering data 7	2261	----	○	×	×	×	
Additional buffering data 8	2262	----	○	×	×	×	
Additional buffering data 9	2263	----	○	×	×	×	
Additional buffering data 10	2264	----	○	×	×	×	
No.14	PV value CH1	2265	----	○	×	×	×
	PV value CH2	2266	----	○	×	×	×
	PV value CH3	2267	----	○	×	×	×
	PV value CH4	2268	----	○	×	×	×
	SP value CH1	2269	----	○	×	×	×
	SP value CH2	2270	----	○	×	×	×
	SP value CH3	2271	----	○	×	×	×
	SP value CH4	2272	----	○	×	×	×
	CT value CH1	2273	----	○	×	×	×
	CT value CH2	2274	----	○	×	×	×
	All alarm representative	2275	----	○	×	×	×
	PV alarm details	2276	----	○	×	×	×
	Control-related information *1	2277	----	○	×	×	×
	Results of internal operation on event output/external switch input	2278	----	○	×	×	×
	External switch input state	2279	----	○	×	×	×
	Event output/control output state	2280	----	○	×	×	×
	Communications DI *2	2281	----	○	×	×	×
	Control-related status	2282	----	○	×	×	×
	Additional buffering data 1	2283	----	○	×	×	×
	Additional buffering data 2	2284	----	○	×	×	×
	Additional buffering data 3	2285	----	○	×	×	×
	Additional buffering data 4	2286	----	○	×	×	×
	Additional buffering data 5	2287	----	○	×	×	×
	Additional buffering data 6	2288	----	○	×	×	×
Additional buffering data 7	2289	----	○	×	×	×	
Additional buffering data 8	2290	----	○	×	×	×	
Additional buffering data 9	2291	----	○	×	×	×	
Additional buffering data 10	2292	----	○	×	×	×	

DMC10	Item	Address		RAM		ROM	
		RAM	ROM	R	W	R	W
No.15	PV value CH1	2293	----	○	×	×	×
	PV value CH2	2294	----	○	×	×	×
	PV value CH3	2295	----	○	×	×	×
	PV value CH4	2296	----	○	×	×	×
	SP value CH1	2297	----	○	×	×	×
	SP value CH2	2298	----	○	×	×	×
	SP value CH3	2299	----	○	×	×	×
	SP value CH4	2300	----	○	×	×	×
	CT value CH1	2301	----	○	×	×	×
	CT value CH2	2302	----	○	×	×	×
	All alarm representative	2303	----	○	×	×	×
	PV alarm details	2304	----	○	×	×	×
	Control-related information *1	2305	----	○	×	×	×
	Results of internal operation on event output/external switch input	2306	----	○	×	×	×
	External switch input state	2307	----	○	×	×	×
	Event output/control output state	2308	----	○	×	×	×
	Communications DI *2	2309	----	○	×	×	×
	Control-related status	2310	----	○	×	×	×
	Additional buffering data 1	2311	----	○	×	×	×
	Additional buffering data 2	2312	----	○	×	×	×
	Additional buffering data 3	2313	----	○	×	×	×
	Additional buffering data 4	2314	----	○	×	×	×
	Additional buffering data 5	2315	----	○	×	×	×
	Additional buffering data 6	2316	----	○	×	×	×
Additional buffering data 7	2317	----	○	×	×	×	
Additional buffering data 8	2318	----	○	×	×	×	
Additional buffering data 9	2319	----	○	×	×	×	
Additional buffering data 10	2320	----	○	×	×	×	

*1, 2: For details on control-related information and communications DI, see page 35.

*1: Control-related information (data not on DMC10s)

Bit	Item	Value	Remarks
Bit 0	When CH1 is in Auto/ManualManual mode = 1		
Bit 1	When CH1 is in Run/ReadyReady mode = 1		
Bit 2	When CH1 is in Local/RemoteRemote mode = 1		
Bit 3	When auto-tuning is stopped/in progress on CH1	Auto-tuning in progress on CH1 = 1	
Bit 4	When CH2 is in Auto/ManualManual mode = 1		
Bit 5	When CH2 is in Run/ReadyReady mode = 1		
Bit 6	When CH2 is in Local/RemoteRemote mode = 1		
Bit 7	When auto-tuning is stopped/in progress on CH2	Auto-tuning in progress on CH1 = 1	
Bit 8	When CH3 is in Auto/ManualManual mode = 1		
Bit 9	When CH3 is in Run/ReadyReady mode = 1		
Bit 10	When CH3 is in Local/RemoteRemote mode = 1		
Bit 11	When auto-tuning is stopped/in progress on CH3	Auto-tuning in progress on CH1 = 1	
Bit 12	When CH4 is in Auto/ManualManual mode = 1		
Bit 13	When CH4 is in Run/ReadyReady mode = 1		
Bit 14	When CH4 is in Local/RemoteRemote mode = 1		
Bit 15	When auto-tuning is stopped/in progress on CH4	Auto-tuning in progress on CH1 = 1	

*2: Communications DI (data not on DMC10s)

Bit	Item	Value	Remarks
Bit 0	Communications DI1	0, 1	
Bit 1	Communications DI2	0, 1	
Bit 2	Communications DI3	0, 1	
Bit 3	Communications DI4	0, 1	
Bit 4	Reserved	0 at all times	
Bit 5	Reserved	0 at all times	
Bit 6	Reserved	0 at all times	
Bit 7	Reserved	0 at all times	
Bit 8	Reserved	0 at all times	
Bit 9	Reserved	0 at all times	
Bit 10	Reserved	0 at all times	
Bit 11	Reserved	0 at all times	
Bit 12	Reserved	0 at all times	
Bit 13	Reserved	0 at all times	
Bit 14	Reserved	0 at all times	
Bit 15	Reserved	0 at all times	

■ SDU10 Work Sheet

● SDU10 setup

Person in charge	Model No.	
	Drawn Up	/ / (Y/M/D)

Function Prompt	Item	Value
C01	Key lock	
C02	Slave device setting	
C03	Device address	
C04	Host communications settings	
C05	Slave communications settings	
C06	Display method in Run mode	
C07	LED operation type	
C08	RDY key function	
C09	Event 1 operation type	
C10	Event 2 operation type	
C11	External switch input 1 operation type	
C12	External switch input 2 operation type	
C13	External switch input 3 operation type	
C14	External switch input 4 operation type	
C15	External switch input 5 operation type	
C16	External switch input 6 operation type	
C17	External switch input 7 operation type	
C18	External switch input 8 operation type	
C19	Number of user-defined items	
C20	Number of additional buffers	
C21	Number of recipe items	
C22	Number of recipe sets	
C27	Execute automatic detection	
C28	Automatic detection results	
C30	User-defined item 1 address	
C31	User-defined item 2 address	
C32	User-defined item 3 address	
C33	User-defined item 4 address	
C34	User-defined item 5 address	
C35	User-defined item 6 address	
C36	User-defined item 7 address	
C37	User-defined item 8 address	
C38	User-defined item 9 address	
C39	User-defined item 10 address	
C40	User-defined item 11 address	
C41	User-defined item 12 address	
C42	User-defined item 13 address	
C43	User-defined item 14 address	
C44	User-defined item 15 address	
C45	User-defined item 16 address	
C46	User-defined item 17 address	
C47	User-defined item 18 address	
C48	User-defined item 19 address	
C49	User-defined item 20 address	
C50	User-defined item 1 name	
C51	User-defined item 2 name	
C52	User-defined item 3 name	

Function Prompt	Item	Value
C53	User-defined item 4 name	
C54	User-defined item 5 name	
C55	User-defined item 6 name	
C56	User-defined item 7 name	
C57	User-defined item 8 name	
C58	User-defined item 9 name	
C59	User-defined item 10 name	
C60	User-defined item 11 name	
C61	User-defined item 12 name	
C62	User-defined item 13 name	
C63	User-defined item 14 name	
C64	User-defined item 15 name	
C65	User-defined item 16 name	
C66	User-defined item 17 name	
C67	User-defined item 18 name	
C68	User-defined item 19 name	
C69	User-defined item 20 name	
C70	User-defined item 1 decimal point	
C71	User-defined item 2 decimal point	
C72	User-defined item 3 decimal point	
C73	User-defined item 4 decimal point	
C74	User-defined item 5 decimal point	
C75	User-defined item 6 decimal point	
C76	User-defined item 7 decimal point	
C77	User-defined item 8 decimal point	
C78	User-defined item 9 decimal point	
C79	User-defined item 10 decimal point	
C80	User-defined item 11 decimal point	
C81	User-defined item 12 decimal point	
C82	User-defined item 13 decimal point	
C83	User-defined item 14 decimal point	
C84	User-defined item 15 decimal point	
C85	User-defined item 16 decimal point	
C86	User-defined item 17 decimal point	
C87	User-defined item 18 decimal point	
C88	User-defined item 19 decimal point	
C89	User-defined item 20 decimal point	
C90	Additional buffering address 1	
C91	Additional buffering address 2	
C92	Additional buffering address 3	
C93	Additional buffering address 4	
C94	Additional buffering address 5	
C95	Additional buffering address 6	
C96	Additional buffering address 7	
C97	Additional buffering address 8	
C98	Additional buffering address 9	
C99	Additional buffering address 10	

● SDU10 recipe items

Function Prompt	Item	Value
r1	Recipe item 1	
r2	Recipe item 2	
r3	Recipe item 3	
r4	Recipe item 4	
r5	Recipe item 5	
r6	Recipe item 6	
r7	Recipe item 7	
r8	Recipe item 8	
r9	Recipe item 9	
r10	Recipe item 10	
r11	Recipe item 11	
r12	Recipe item 12	
r13	Recipe item 13	
r14	Recipe item 14	
r15	Recipe item 15	
r16	Recipe item 16	
r17	Recipe item 17	
r18	Recipe item 18	
r19	Recipe item 19	
r20	Recipe item 20	
r21	Recipe item 21	
r22	Recipe item 22	
r23	Recipe item 23	
r24	Recipe item 24	
r25	Recipe item 25	
r26	Recipe item 26	
r27	Recipe item 27	
r28	Recipe item 28	
r29	Recipe item 29	
r30	Recipe item 30	
r31	Recipe item 31	
r32	Recipe item 32	
r33	Recipe item 33	
r34	Recipe item 34	
r35	Recipe item 35	
r36	Recipe item 36	
r37	Recipe item 37	
r38	Recipe item 38	
r39	Recipe item 39	
r40	Recipe item 40	
r41	Recipe item 41	
r42	Recipe item 42	
r43	Recipe item 43	
r44	Recipe item 44	
r45	Recipe item 45	
r46	Recipe item 46	
r47	Recipe item 47	
r48	Recipe item 48	
r49	Recipe item 49	
r50	Recipe item 50	

Function Prompt	Item	Value
r51	Recipe item 51	
r52	Recipe item 52	
r53	Recipe item 53	
r54	Recipe item 54	
r55	Recipe item 55	
r56	Recipe item 56	
r57	Recipe item 57	
r58	Recipe item 58	
r59	Recipe item 59	
r60	Recipe item 60	
r61	Recipe item 61	
r62	Recipe item 62	
r63	Recipe item 63	
r64	Recipe item 64	
r65	Recipe item 65	
r66	Recipe item 66	
r67	Recipe item 67	
r68	Recipe item 68	
r69	Recipe item 69	
r70	Recipe item 70	
r71	Recipe item 71	
r72	Recipe item 72	
r73	Recipe item 73	
r74	Recipe item 74	
r75	Recipe item 75	
r76	Recipe item 76	
r77	Recipe item 77	
r78	Recipe item 78	
r79	Recipe item 79	
r80	Recipe item 80	
r81	Recipe item 81	
r82	Recipe item 82	
r83	Recipe item 83	
r84	Recipe item 84	
r85	Recipe item 85	
r86	Recipe item 86	
r87	Recipe item 87	
r88	Recipe item 88	
r89	Recipe item 89	
r90	Recipe item 90	
r91	Recipe item 91	
r92	Recipe item 92	
r93	Recipe item 93	
r94	Recipe item 94	
r95	Recipe item 95	
r96	Recipe item 96	
r97	Recipe item 97	
r98	Recipe item 98	
r99	Recipe item 99	
r100	Recipe item 100	

● SDU10 recipe sets

Function Prompt	Item	Value
r101	Recipe item 101	
r102	Recipe item 102	
r103	Recipe item 103	
r104	Recipe item 104	
r105	Recipe item 105	
r106	Recipe item 106	
r107	Recipe item 107	
r108	Recipe item 108	
r109	Recipe item 109	
r110	Recipe item 110	
r111	Recipe item 111	
r112	Recipe item 112	
r113	Recipe item 113	
r114	Recipe item 114	
r115	Recipe item 115	
r116	Recipe item 116	
r117	Recipe item 117	
r118	Recipe item 118	
r119	Recipe item 119	
r120	Recipe item 120	
r121	Recipe item 121	
r122	Recipe item 122	
r123	Recipe item 123	
r124	Recipe item 124	
r125	Recipe item 125	
r126	Recipe item 126	
r127	Recipe item 127	
r128	Recipe item 128	
r129	Recipe item 129	
r130	Recipe item 130	
r131	Recipe item 131	
r132	Recipe item 132	
r133	Recipe item 133	
r134	Recipe item 134	
r135	Recipe item 135	
r136	Recipe item 136	
r137	Recipe item 137	
r138	Recipe item 138	
r139	Recipe item 139	
r140	Recipe item 140	
r141	Recipe item 141	
r142	Recipe item 142	
r143	Recipe item 143	
r144	Recipe item 144	
r145	Recipe item 145	
r146	Recipe item 146	
r147	Recipe item 147	
r148	Recipe item 148	
r149	Recipe item 149	
r150	Recipe item 150	

Function Prompt	Item	Value
r151	Recipe item 151	
r152	Recipe item 152	
r153	Recipe item 153	
r154	Recipe item 154	
r155	Recipe item 155	
r156	Recipe item 156	
r157	Recipe item 157	
r158	Recipe item 158	
r159	Recipe item 159	
r160	Recipe item 160	
r161	Recipe item 161	
r162	Recipe item 162	
r163	Recipe item 163	
r164	Recipe item 164	
r165	Recipe item 165	
r166	Recipe item 166	
r167	Recipe item 167	
r168	Recipe item 168	
r169	Recipe item 169	
r170	Recipe item 170	
r171	Recipe item 171	
r172	Recipe item 172	
r173	Recipe item 173	
r174	Recipe item 174	
r175	Recipe item 175	
r176	Recipe item 176	
r177	Recipe item 177	
r178	Recipe item 178	
r179	Recipe item 179	
r180	Recipe item 180	
r181	Recipe item 181	
r182	Recipe item 182	
r183	Recipe item 183	
r184	Recipe item 184	
r185	Recipe item 185	
r186	Recipe item 186	
r187	Recipe item 187	
r188	Recipe item 188	
r189	Recipe item 189	
r190	Recipe item 190	
r191	Recipe item 191	
r192	Recipe item 192	
r193	Recipe item 193	
r194	Recipe item 194	
r195	Recipe item 195	
r196	Recipe item 196	
r197	Recipe item 197	
r198	Recipe item 198	
r199	Recipe item 199	

Function Prompt	Item	Value
rf1	Recipe set 1	
rf2	Recipe set 2	
rf3	Recipe set 3	
rf4	Recipe set 4	
rf5	Recipe set 5	
rf6	Recipe set 6	
rf7	Recipe set 7	
rf8	Recipe set 8	
rf9	Recipe set 9	
rf10	Recipe set 10	
rf11	Recipe set 11	
rf12	Recipe set 12	
rf13	Recipe set 13	
rf14	Recipe set 14	
rf15	Recipe set 15	
rf16	Recipe set 16	
rf17	Recipe set 17	
rf18	Recipe set 18	
rf19	Recipe set 19	
rf20	Recipe set 20	
rf21	Recipe set 21	
rf22	Recipe set 22	
rf23	Recipe set 23	
rf24	Recipe set 24	
rf25	Recipe set 25	
rf26	Recipe set 26	
rf27	Recipe set 27	
rf28	Recipe set 28	
rf29	Recipe set 29	
rf30	Recipe set 30	
rf31	Recipe set 31	
rf32	Recipe set 32	
rf33	Recipe set 33	
rf34	Recipe set 34	
rf35	Recipe set 35	
rf36	Recipe set 36	
rf37	Recipe set 37	
rf38	Recipe set 38	
rf39	Recipe set 39	
rf40	Recipe set 40	
rf41	Recipe set 41	
rf42	Recipe set 42	
rf43	Recipe set 43	
rf44	Recipe set 44	
rf45	Recipe set 45	
rf46	Recipe set 46	
rf47	Recipe set 47	
rf48	Recipe set 48	
rf49	Recipe set 49	
rf50	Recipe set 50	

Function Prompt	Item	Value
rf51	Recipe set 51	
rf52	Recipe set 52	
rf53	Recipe set 53	
rf54	Recipe set 54	
rf55	Recipe set 55	
rf56	Recipe set 56	
rf57	Recipe set 57	
rf58	Recipe set 58	
rf59	Recipe set 59	
rf60	Recipe set 60	
rf61	Recipe set 61	
rf62	Recipe set 62	
rf63	Recipe set 63	
rf64	Recipe set 64	
rf65	Recipe set 65	
rf66	Recipe set 66	
rf67	Recipe set 67	
rf68	Recipe set 68	
rf69	Recipe set 69	
rf70	Recipe set 70	
rf71	Recipe set 71	
rf72	Recipe set 72	
rf73	Recipe set 73	
rf74	Recipe set 74	
rf75	Recipe set 75	
rf76	Recipe set 76	
rf77	Recipe set 77	
rf78	Recipe set 78	
rf79	Recipe set 79	
rf80	Recipe set 80	
rf81	Recipe set 81	
rf82	Recipe set 82	
rf83	Recipe set 83	
rf84	Recipe set 84	
rf85	Recipe set 85	
rf86	Recipe set 86	
rf87	Recipe set 87	
rf88	Recipe set 88	
rf89	Recipe set 89	
rf90	Recipe set 90	
rf91	Recipe set 91	
rf92	Recipe set 92	
rf93	Recipe set 93	
rf94	Recipe set 94	
rf95	Recipe set 95	
rf96	Recipe set 96	
rf97	Recipe set 97	
rf98	Recipe set 98	
rf99	Recipe set 99	

Specifications are subject to change without notice.

YAMATAKE

Yamatake Corporation

Control Product Division

Sales contact: Yamatake Corporation,
IBD Sensing and Control Department

Totate International Building

2-12-19 Shibuya Shibuya-ku Tokyo 150-8316 Japan

Phone: 81-3-3486-2380

Fax: 81-3-3486-2300

This has been printed on recycled paper.

Printed in Japan.
1st Edition: Issued in Dec., 2000(R)