

# Large size Color Programmable Display Smart Terminal EST555Z

The EST555Z Smart Terminal is a next-generation large size programmable display adopting the multi-channel communication and memory card. This Smart Terminal uses a high-precision TFT device.

It has the capability of producing vividly 256-color display with drawings of bit-mapped images, etc., and the application creation can be simply worked out with a new AP editor coping with Windows 98/Me/XP.

Smart objects (pictures + operating settings) can be selected from the library like the feeling of pasting them. Several interfaces to external devices are provided, such as serial communication port, infrared ray transmission port (IrDA), and memory card (compact flash memory card).

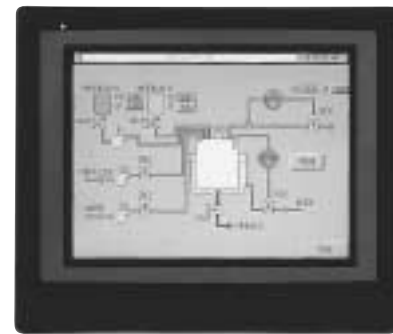

## ■ Features

- Multi-channel structure with RS-232C (one channel), RS-485 (3-channel) and infrared ray transmission port provided on the front side. It can also cope with the same applications to support simultaneously programmable logic controllers (PLCs) and controllers.
- Instrumentation objects are available that allow long-term storage of up to 64-channel data. (The data can be stored for approximately 3 months assuming that the interval is 30 sec.)
- The DMC10 package is available to realize the loader and the monitoring functions of module type controllers without programming.
- Realized 256-color display with vivid image drawings. It can clearly draw the images taken by a digital camera.
- The software of the AP editor for picture creation is considerably enhanced in its maneuverability to cope with Windows 98/Me/XP. Furthermore, it can gently support the creation of application data by utilizing smart objects.
- Easy to replace the components such as the display unit from front side, thus, providing the easiness in maintenance.
- The protective structure of IP64 is assured despite of the provision for the infrared ray transmission port. The installation location is not restricted.
- The memory card (compact flash memory card) is provided on the front. Use of this memory card makes it possible to save or transmit applications and to save the trend data using the instrumentation objects.

## ■ System Configuration

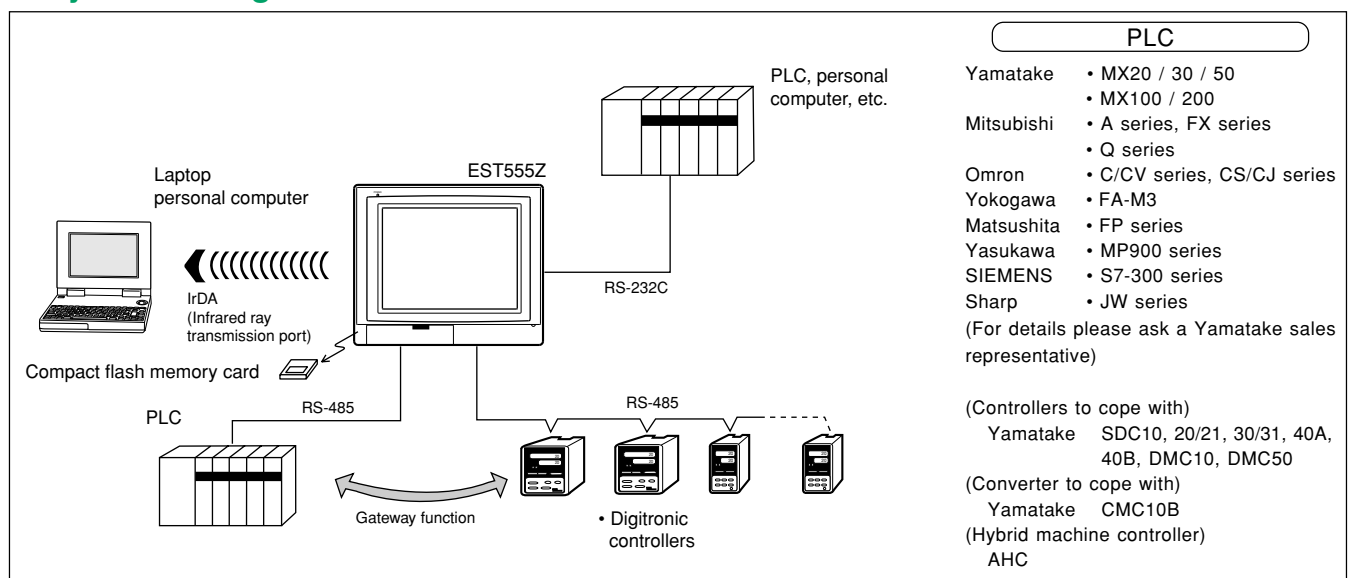

## ■ Name of Each Component

### ● The front

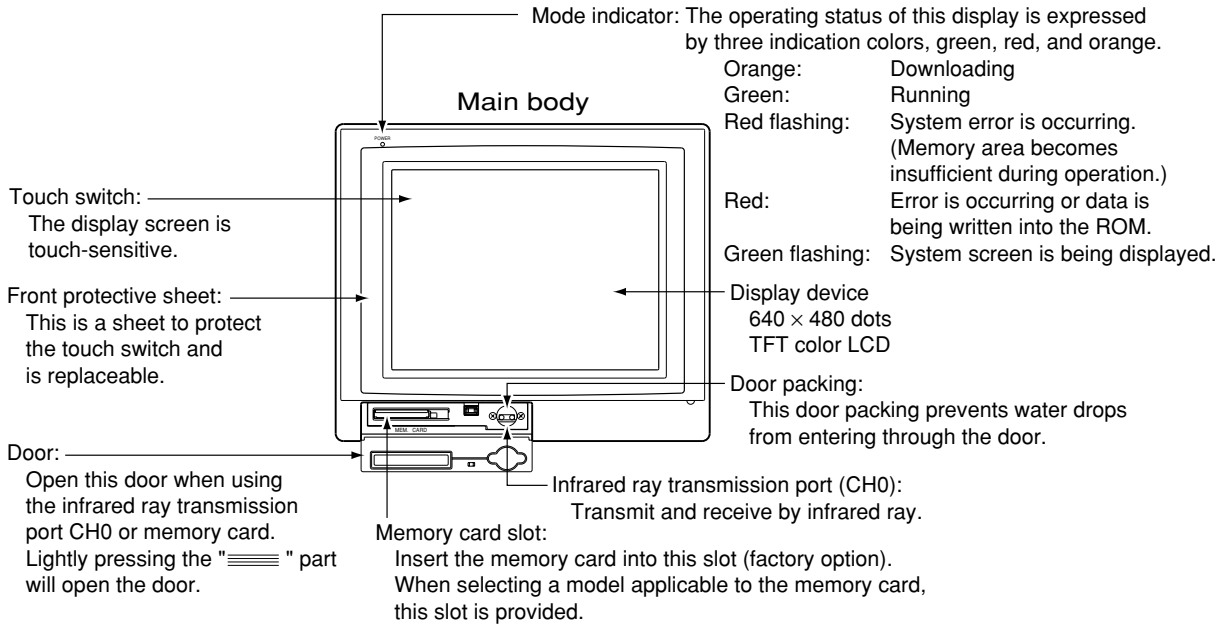

### ● The rear

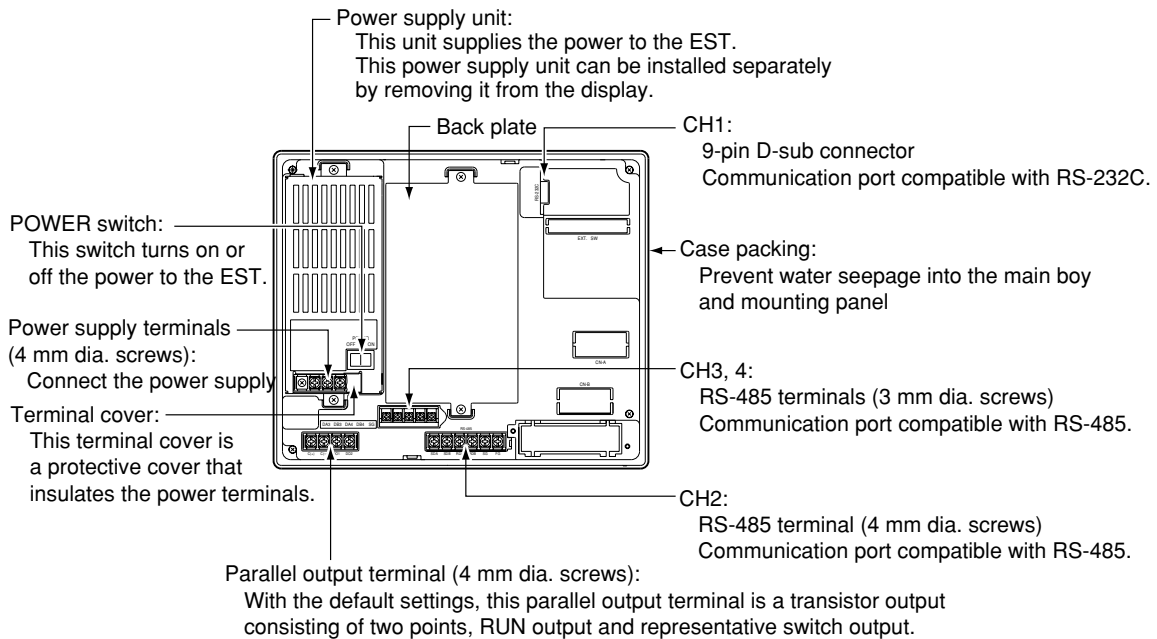



## ■ Part material and environment resistance

Part	Material	
Case display unit chassis	PC/ABS	Rather being resistant to water, alcohol, oil, salt and weak acid but has effects of swelling and dissolution by alkaline, aromatic hydrocarbon and halogen acid.
Touch switch front protective sheet	PET (polyethylene terephthalate)	PET is susceptible to damage by strong acid, alkaline, boiling water and water and water vapor but has extremely high resistance to organic solvent and oily substances.
Door packing	EPDM (Ethylene propylene rubber)	The surface material is a continuous foaming type flexible foam material that the mixture, in which the flame retardant is mixed with EPDM, is foamed General mineral oil may adversely affect this rubber. The ozone resistance is excellent, and the heat resistance and heat aging resistance are good, ensuring the good resistance to the over-heated steam.
Case packing	CR (Chloroprene rubber)	The raw material is a flexible foam material having the independent foaming structure that CR is foamed. The ozone resistance is excellent next to EPDM, and the heat resistance and oil resistance are good. This material also has the autolysis ability.
Back plate	Incombustible/heat-resistant vinyl chloride sheet	Material has rigidity insulation resistance, excellent weatherability, water resistance and chemical resistance. It has low resistance to hydro-carbon, ester, ketone, aldehyde, uric acid, chlorinated solvent and rosin.

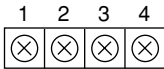
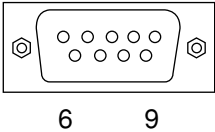
## ■ Specifications

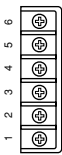
<b>Display unit</b>	<b>Display element</b>	TFT color LCD																																																										
	<b>Display color</b>	256 colors (bitmap display) / 64 colors (object display)																																																										
	<b>Resolution</b>	640 × 480 dots																																																										
	<b>Dot pitch</b>	0.33 mm																																																										
	<b>Display unit life (at room temperature)</b>	50,000 hrs.																																																										
	<b>Back-light life (at room temperature)</b>	Approx. 30,000 hrs. at room temperature in a half brightness (before date code 0208), Approx. 50,000 hrs. (after date code 0212)																																																										
	<b>Back light</b>	Turning-off is possible by time setting																																																										
	<b>Display attribute</b>	Blinking and color change																																																										
	<b>Display character type</b>	ANK: 158, kanji character: 6349 (including 453 symbols, JIS level 1 and 2 kanji sets)																																																										
	<b>Display character number</b>	80-character × 60-line (8 × 8 dots)																																																										
		80-character × 30-line (8 × 16 dots)																																																										
		40-character × 30-line (16 × 16 dots)																																																										
	<b>Display character size</b>	1 to 8 integers in vertical and horizontal directions																																																										
	<b>Graphic element</b>	Straight line, rectangle, circle, circular arc, ellipse, optional patterns, etc.																																																										
	<b>Graphic display</b>	Bar graph and line graph																																																										
<b>Display unit function</b>	Numeric, lamp display, character string, sub-screen display, etc.																																																											
<b>Screen memory</b>	<b>Memory capacity</b>	2 M bytes																																																										
	<b>No. of registered screens</b>	999 panels (maximum number changes depending applications)																																																										
	<b>Panel display</b>	Simultaneously up to 8 panels																																																										
<b>Touch switch</b>	<b>Switching method</b>	Transparent resistance membrane																																																										
	<b>Life</b>	1 million times (by finger inputting)																																																										
<b>DC input/output interface</b>	<b>Point number</b>	Output: 2																																																										
	<b>Output form</b>	NPN transistor																																																										
	<b>Dielectric strength</b>	30 Vdc																																																										
	<b>Leak current</b>	0.3 mA max.																																																										
	<b>Load voltage range</b>	4.5 to 27.6 Vdc, 10mA																																																										
	<b>Connector</b>	4 mm dia. terminal block																																																										
		 <table border="1" data-bbox="785 1122 1331 1276"> <thead> <tr> <th>Pin No.</th> <th>Signal name</th> <th>Contents</th> </tr> </thead> <tbody> <tr> <td>1</td> <td>C (+)</td> <td>Power supply input for output signal</td> </tr> <tr> <td>2</td> <td>C (-)</td> <td>Output signal ground</td> </tr> <tr> <td>3</td> <td>DO1</td> <td>Output signal 1</td> </tr> <tr> <td>4</td> <td>DO2</td> <td>Output signal 2</td> </tr> </tbody> </table>				Pin No.	Signal name	Contents	1	C (+)	Power supply input for output signal	2	C (-)	Output signal ground	3	DO1	Output signal 1	4	DO2	Output signal 2																																								
Pin No.	Signal name	Contents																																																										
1	C (+)	Power supply input for output signal																																																										
2	C (-)	Output signal ground																																																										
3	DO1	Output signal 1																																																										
4	DO2	Output signal 2																																																										
<b>Communications (CH0) Interface</b>	<b>Communications standard</b>	Infrared ray communications (IrDA 1.0 equipment)																																																										
	<b>Transmission distance</b>	0.4 to 1 m																																																										
	<b>Unit connection number</b>	1 unit																																																										
	<b>Transmission speed</b>	9600, 19200, 38400, 57600 and 115200 bps																																																										
<b>Communications (CH1) Interface</b>	<b>Communication standard</b>	RS-232C equipment																																																										
	<b>Transmission distance</b>	15 m																																																										
	<b>Unit connection number</b>	1 unit																																																										
	<b>Transmission speed</b>	9600, 19200, 38400, 57600, and 11520 bps																																																										
	<b>Connector</b>	Applicable connector: Daiich Denshi Kogyo Co. 17JE-13090-02 (D8C2) or equivalent D - sub 9 pin																																																										
		 <table border="1" data-bbox="785 1738 1485 2092"> <thead> <tr> <th>Pin No.</th> <th>Signal name</th> <th>Contents</th> <th>Channel</th> <th>Input/Output</th> </tr> </thead> <tbody> <tr> <td>1</td> <td>NC</td> <td>No connection</td> <td></td> <td></td> </tr> <tr> <td>2</td> <td>RD1</td> <td>Receive data</td> <td>CH1</td> <td>Input</td> </tr> <tr> <td>3</td> <td>SD1</td> <td>Send data</td> <td>CH1</td> <td>Output</td> </tr> <tr> <td>4</td> <td>ER1</td> <td>DR (6-pin) and internal connection</td> <td>CH1</td> <td></td> </tr> <tr> <td>5</td> <td>SG</td> <td>Signal ground</td> <td></td> <td></td> </tr> <tr> <td>6</td> <td>DR1</td> <td>ER (4-pin) and internal connection</td> <td>CH1</td> <td></td> </tr> <tr> <td>7</td> <td>RS1</td> <td>Request to send</td> <td>CH1</td> <td>Output</td> </tr> <tr> <td>8</td> <td>CS1</td> <td>Transmission enable</td> <td>CH1</td> <td>Input</td> </tr> <tr> <td>9</td> <td>NC</td> <td>No connection</td> <td></td> <td></td> </tr> <tr> <td>Shell</td> <td>-</td> <td>No connection</td> <td></td> <td></td> </tr> </tbody> </table>				Pin No.	Signal name	Contents	Channel	Input/Output	1	NC	No connection			2	RD1	Receive data	CH1	Input	3	SD1	Send data	CH1	Output	4	ER1	DR (6-pin) and internal connection	CH1		5	SG	Signal ground			6	DR1	ER (4-pin) and internal connection	CH1		7	RS1	Request to send	CH1	Output	8	CS1	Transmission enable	CH1	Input	9	NC	No connection			Shell	-	No connection		
Pin No.	Signal name	Contents	Channel	Input/Output																																																								
1	NC	No connection																																																										
2	RD1	Receive data	CH1	Input																																																								
3	SD1	Send data	CH1	Output																																																								
4	ER1	DR (6-pin) and internal connection	CH1																																																									
5	SG	Signal ground																																																										
6	DR1	ER (4-pin) and internal connection	CH1																																																									
7	RS1	Request to send	CH1	Output																																																								
8	CS1	Transmission enable	CH1	Input																																																								
9	NC	No connection																																																										
Shell	-	No connection																																																										

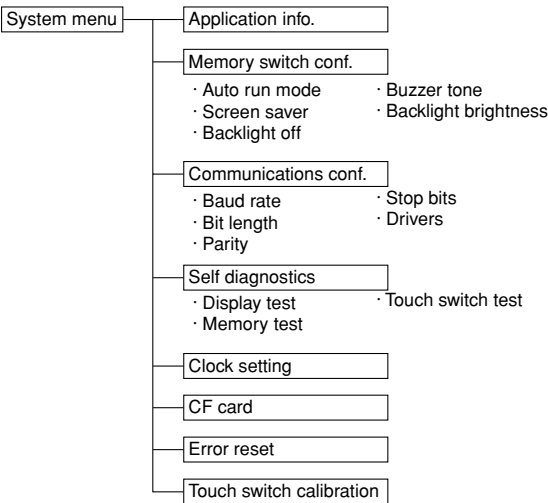
<b>Communications (CH2) Interface</b>	<b>Communication standard</b>	RS-485 equivalent (full duplex/half duplex)																																						
	<b>Transmission distance</b>	1000 m																																						
	<b>Unit connection number</b>	31 units																																						
	<b>Transmission speed</b>	4800, 9600, 19200, 38400, 57600 and 115200 bps																																						
	<b>Connector</b>	4 mm dia. terminal block																																						
		<table border="1"> <thead> <tr> <th>Pin No.</th> <th>Signal name</th> <th>Contents</th> <th>Channel</th> <th>Input/Output</th> </tr> </thead> <tbody> <tr> <td>1</td> <td>SDA2</td> <td>Send data (+)</td> <td>CH2</td> <td>Output</td> </tr> <tr> <td>2</td> <td>SDB2</td> <td>Send data (-)</td> <td>CH2</td> <td>Output</td> </tr> <tr> <td>3</td> <td>RDA2</td> <td>Receive data (+)</td> <td>CH2</td> <td>Input</td> </tr> <tr> <td>4</td> <td>RDB2</td> <td>Receive data (-)</td> <td>CH2</td> <td>Input</td> </tr> <tr> <td>5</td> <td>SG</td> <td>Signal ground</td> <td></td> <td></td> </tr> <tr> <td>6</td> <td>FG</td> <td>For frame ground relay</td> <td></td> <td></td> </tr> </tbody> </table>	Pin No.	Signal name	Contents	Channel	Input/Output	1	SDA2	Send data (+)	CH2	Output	2	SDB2	Send data (-)	CH2	Output	3	RDA2	Receive data (+)	CH2	Input	4	RDB2	Receive data (-)	CH2	Input	5	SG	Signal ground			6	FG	For frame ground relay					
Pin No.	Signal name	Contents	Channel	Input/Output																																				
1	SDA2	Send data (+)	CH2	Output																																				
2	SDB2	Send data (-)	CH2	Output																																				
3	RDA2	Receive data (+)	CH2	Input																																				
4	RDB2	Receive data (-)	CH2	Input																																				
5	SG	Signal ground																																						
6	FG	For frame ground relay																																						
<b>Communications (CH3, CH4) Interface</b>	<b>Communication standard</b>	RS-485 equivalent (half duplex)																																						
	<b>Transmission distance</b>	1000 m																																						
	<b>Unit connection number</b>	31 units																																						
	<b>Transmission speed</b>	4800, 9600, 19200, 38400 bps																																						
	<b>Connector</b>	3 mm dia. terminal block																																						
		<table border="1"> <thead> <tr> <th>Pin No.</th> <th>Signal name</th> <th>Contents</th> <th>Channel</th> <th>Input/Output</th> </tr> </thead> <tbody> <tr> <td>1</td> <td>DA3</td> <td>Send/receive data (+)</td> <td>CH3</td> <td>Input/Output</td> </tr> <tr> <td>2</td> <td>DB3</td> <td>Send/receive data (-)</td> <td>CH3</td> <td>Input/Output</td> </tr> <tr> <td>3</td> <td>DA4</td> <td>Send/receive data (+)</td> <td>CH4</td> <td>Input/Output</td> </tr> <tr> <td>4</td> <td>DB4</td> <td>Send/receive data (-)</td> <td>CH4</td> <td>Input/Output</td> </tr> <tr> <td>5</td> <td>SG</td> <td>Signal ground</td> <td></td> <td></td> </tr> </tbody> </table>	Pin No.	Signal name	Contents	Channel	Input/Output	1	DA3	Send/receive data (+)	CH3	Input/Output	2	DB3	Send/receive data (-)	CH3	Input/Output	3	DA4	Send/receive data (+)	CH4	Input/Output	4	DB4	Send/receive data (-)	CH4	Input/Output	5	SG	Signal ground										
Pin No.	Signal name	Contents	Channel	Input/Output																																				
1	DA3	Send/receive data (+)	CH3	Input/Output																																				
2	DB3	Send/receive data (-)	CH3	Input/Output																																				
3	DA4	Send/receive data (+)	CH4	Input/Output																																				
4	DB4	Send/receive data (-)	CH4	Input/Output																																				
5	SG	Signal ground																																						
		<p><b>ⓘ Precautions in Handling</b>            CH3 and CH4 are for RS-485 duplex communication. Dedicated output terminals (RSA and RSB) are required when the Mitsubishi CPU direct communication mode is designated.</p>																																						
<b>System menu</b>	Basically an application can make each setting but the setting can be changed by the Smart terminal.																																							
																																								
<b>Application info.</b>	Display built-in application file names and down-load dates																																							
<b>Memory switch conf.</b>	Automatic run start	Wait time till starting is set to find if the automatic run starts at power input																																						
	Screen saver start	Wait time till starting is set to find is screen saver starts to run																																						
	Automatic back light off	Wait time till starting is set to find if the back-light is automatically turned off.																																						
	Buzzer tone	Selection of high, medium and low is possible.																																						
	LCD backlight brightness adjustment	Adjust the brightness of the LCD backlight.																																						
<b>Communications conf.</b>	Set the transmission speed for communication port.																																							
<b>Self-diagnostics</b>	Display test	To confirm if LCD is damaged.																																						
	Memory test	Conduct test for internal memory.																																						
	Touch switch test	Conduct test for touch switch.																																						
<b>Clock setting</b>	Adjust the built-in clock.																																							
<b>CF card</b>	To format the CF card and copy the application data.																																							
<b>Error reset</b>	To clear the system error.																																							
<b>Touch switch calib.</b>	To adjust the EST touch switches.																																							

<b>General specifications</b>	<b>Electrical specifications</b>	<b>Supply voltage</b>	85 to 132Vac 50/60Hz 24Vdc $\pm$ 10%		
		<b>Current consumption</b>	AC power supply: 50VA or less DC power supply: 2A or less		
		<b>Allowable instantaneous shut-down</b>	20ms. or less (AC power supply)		
		<b>Dielectric strength</b>	AC power supply: 500Vac for 1 min. (between each signal wire and power input/FG terminal), 1500Vac for 1 min. (between power input and FG terminal) DC power supply: 500Vac for 1 min. (between each signal wire and power input/FG terminal), 500Vac for 1 min. (between power input and FG terminal)		
		<b>Insulation resistance</b>	10M $\Omega$ min. at 500Vdc between power input and FG terminals, and between each signal wire and power input/FG terminals		
		<b>Grounding</b>	Class 3 grounding		
	<b>Environmental specifications</b>	<b>Ambient store temperature</b>	-20 to +60°C		
		<b>Ambient operating temperature</b>	0 to 50°C		
		<b>Store operating humidity range</b>	30 to 85%RH (No condensation allowed) (However, the condition is the same as absolute humidity of 85% at 40°C under above 40°C temperature.		
		<b>Ambient gas</b>	No presence of corrosive gases		
		<b>Vibration resistance</b>	Conform to JIS C 0911. Subjected to 10 to 55 Hz vibrations in X, Y and Z axis directions at 9.8 m/s <sup>2</sup> for 6 minutes of signal sweep and 2 hours in each axis direction		
		<b>Shock resistance</b>	Conform to JIS 0912: Acceleration 98 m/s <sup>2</sup> for 20 ms max.		
		<b>Noise resistance</b>	AC power supply: $\pm$ 1200V DC power supply: $\pm$ 1000V	50 ns to 1 $\mu$ s (by power input and impulse noise simulator)	
	<b>Mechanical specifications</b>	<b>Protective structure</b>	IP64 (dust and drip-proof)		
		<b>External dimensions</b>	250 (H) $\times$ 295 (V) $\times$ 99 (D) mm		
		<b>Weight</b>	2.7 kg		
		<b>Mounting</b>	Vertical panel mounting by fixing from the rear side with metal fittings.		
		<b>Cooling method</b>	Natural cooling		
		<b>Screw tightening torque</b>	0.5N·m (recommended)	CH3, CH4, and 3 mm dia. terminal block	
		<b>Screw tightening torque</b>	1.2N·m (recommended)	Power supply, CH2, DO, 4 mm dia. terminal block, and back plate	
	<b>Metal fittings tightening</b>	From no loose condition of metal fittings in place, make 1/2 to 1 turn further.			

Item	Name	Model No.	Qty	Item	Name	Model No.	Qty
<b>Accessories</b>	Instruction sheet	<b>CP-UM-5229E</b>	1	<b>Replacement part</b>	Backlight (before date code 0208)	<b>ESTX955BL11</b>	1
	Metal fittings	<b>ESTX939FB00</b>	4		Backlight (after date code 0212)	<b>ESTX955BL12</b>	1
<b>Application software (separate order)</b>	AP editor (CD-ROM) coping with Windows 98/Me/XP	<b>ESTX240SWWEC000</b>	1		Protective sheet (For white body)	<b>ESTX955SS10</b>	1
	DMC10 package (3.5 in. FD)	<b>ESX220D5AE 3001</b>	1		(For black body)	<b>ESTX955SS20</b>	1
<b>Separate instruction sheet (separate order)</b>	Instruction sheet hardware edition	<b>CP-SP-1103E</b>	1	<b>Accessories</b>	RS-232C cable (2 m) 9-9 pin	<b>CBL232FFT02</b>	1
					Battery	<b>81446345-001</b>	1
					Compact flash memory card 64 M bytes	<b>SCF0640</b>	1
					Adaptor for PC card conversion	<b>SCFADP000</b>	1

## Model No. Configuration

Model No.	Specifications	Power supply	Memory card	CE marking
EST0555Z01 * EX00	TFT programmable display 10.4"-LCD, 256 colors, 640 x 480 dots	AV100V	Not provided.	Not provided.
EST0555Z01 * ES00		AV100V	Provided.	Not provided.
EST0555Z05 * EX00		DC24V	Not provided.	Not provided.
EST0555Z05 * ES00		DC24V	Provided.	Not provided.
EST0555Z05BEX0M		DC24V	Not provided.	Provided.
EST0555Z05BES0M		DC24V	Provided.	Provided.

\* B: Black case W: White case

The model applicable to the CE marking is only a model having black case and 24Vdc specifications.

## External Dimensions

(Unit: mm)

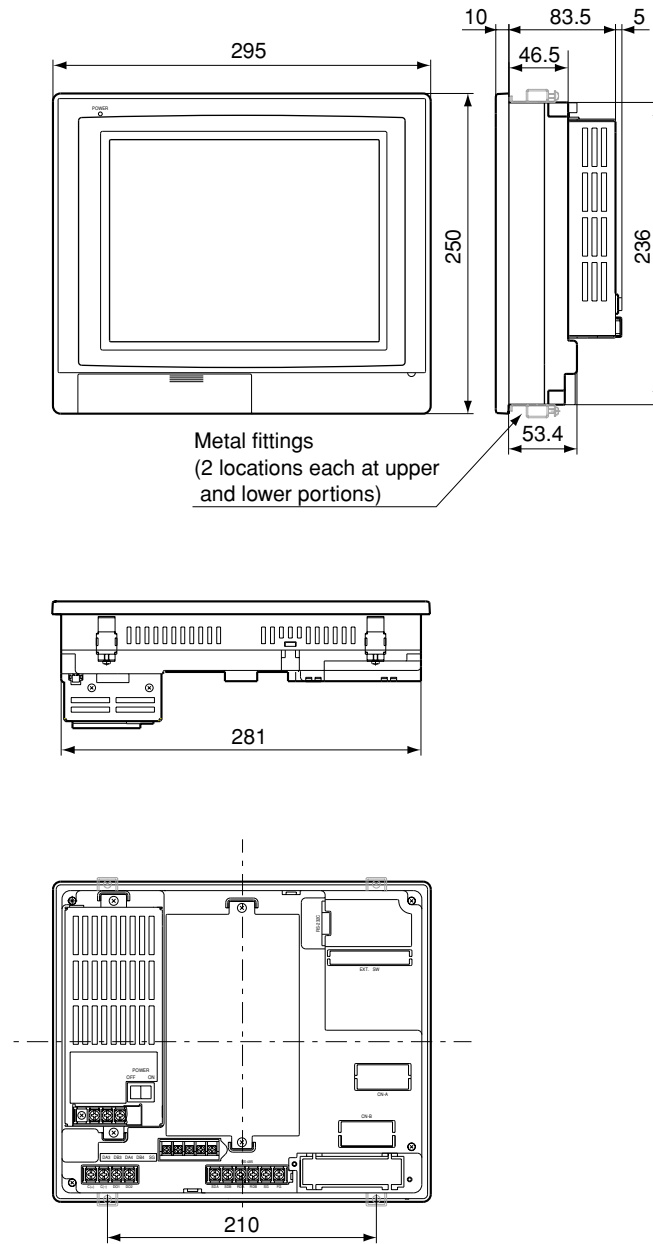

## ■ Panel Cut Dimensions

Cut the panel per the following dimensions and make the panel thickness as  $t =$  a minimum of 1.6.

(Unit: mm)

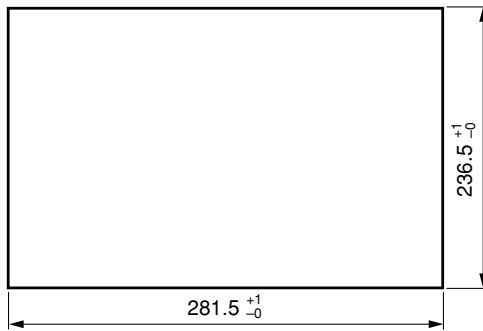

## ■ Mounting

The Smart Terminal is positioned in place from the panel front. Fasten the screws by inserting the mounting metal fittings into the upper and lower body holes. Fix the body by turning additionally a half to one turn from the condition of the fittings being firmly in place.

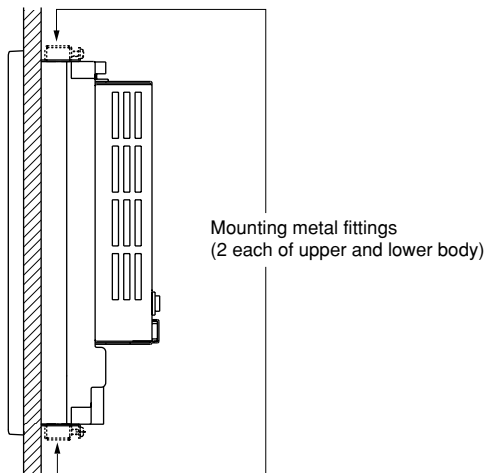

## ! Precautions in Handling

The body case may be deformed or damaged in the excessive tightening of the mounting screws.

\* Windows98/Me/XP are the registered trademarks of Microsoft Corporation in the United States.



## RESTRICTIONS ON USE

This product has been designed, developed and manufactured for general-purpose application in machinery and equipment. Accordingly, when used in applications outlined below, special care should be taken to implement a fail-safe and/or redundant design concept as well as a periodic maintenance program.

- **Units for concerning to control and safety of transportation vehicles (automobiles, trains and ships, etc.)**
- **Traffic control systems**
- **Safety equipment**
- **Anti-disaster systems, anti-crime systems**
- **Medical equipment (not specifically designed for life support)**

Never use this product in applications which require extremely high reliability, such as those outlined below.

- **Aeronautical machines**
- **Submersible repeaters**
- **Life support systems (medical equipment, etc.)**
- **Aerospace machines**
- **Nuclear reactor control systems**

Never use this product in applications where human safety may be put at risk.

Never use this product as a safety switch or as an emergency stop switch.

Special care should be taken to implement a fail-safe and/or redundant design which takes into account the possibility of operational delay, unit damage and malfunction of this product.

*Specifications are subject to change without notice.*

**YAMATAKE**

**Yamatake Corporation**  
**Advanced Automation Company**  
**International Business Headquarters**

Totate International Building  
2-12-19 Shibuya Shibuya-ku  
Tokyo 150-8316 Japan  
URL:<http://www.yamatake.com>

*This has been printed on recycled paper.* (01)

Printed in Japan. (H)  
1st Edition: Issued in Aug., 2003