

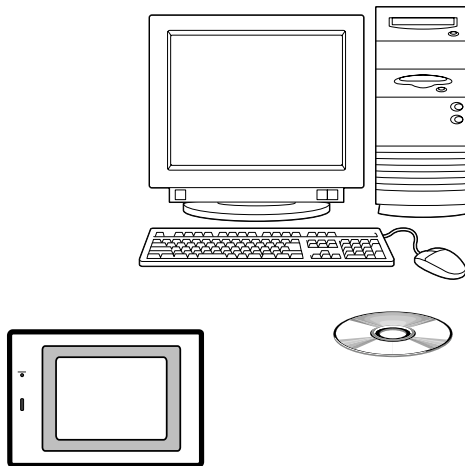

SMART TERMINAL EST240Z

User's Manual

Smart Object Library



Thank you for purchasing the AP Editor for Smart Terminal EST240Z.

This manual describes the smart objects which can be used with the AP Editor to prepare application data for the EST240Z.

This manual should be read by those who use AP Editor to design EST240Z display screens and those responsible for determining operation of the application.

RESTRICTIONS ON USE

When using this product in applications that require particular safety or when using this product in important facilities, pay attention to the safety of the overall system and equipment. For example, install fail-safe mechanisms, carry out redundancy checks and periodic inspections, and adopt other appropriate safety measures as required.

REQUEST

Ensure that this User's Manual is handed over to the user before the product is used.

Copying or duplicating this User's Manual in part or in whole is forbidden. The information and specifications in this User's Manual are subject to change without notice.

Considerable effort has been made to ensure that this User's Manual is free from inaccuracies and omissions.

If you should find any inaccuracies or omissions, please contact Yamatake Corporation.

In no event is Yamatake Corporation liable to anyone for any indirect, special or consequential damages as a result of using this product.

© 2001 Yamatake Corporation ALL RIGHTS RESERVED

The smart terminal ® is a registered trademark of Yamatake Corporation. Other company names and product names listed in this manual are registered trademarks or trademarks of respective companies.

The Role of This Manual

In all, six manuals have been prepared for the **EST240Z**. Read the manual according to your specific requirements. The following lists all the manuals that accompany the **EST240Z** and gives a brief outline of the manual. If you do not have the required manual, contact Yamatake Corporation or your dealer.

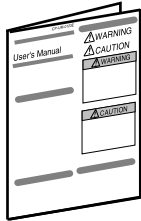

Smart Terminal EST240Z User's Manual Manual No. CP-UM-5145E

This manual is packaged with the EST240Z body.

This manual should be read by those who produce units that use the Smart Terminal.

This manual contains safety precautions when using the Smart Terminal, installation methods, and descriptions for wiring the power supply and signal lines.

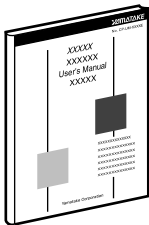

Smart Terminal EST240Z User's Manual Installation Manual No. CP-SP-1065E

This manual should be read by those who use the EST240Z to design units and those in charge of maintenance.

This manual describes safety cautions when using the Smart Terminal, how to install for incorporating into units, wiring methods, maintenance and inspection, troubleshooting, and hardware specifications.

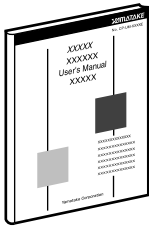

Smart Terminal EST240Z User's Manual Application Preparation Manual No. CP-SP-1088E

This manual should be read by those who design screens that are displayed on the EST240Z and operations.

This manual describes the environment of the personal computer on which AP Editor can be used, installation methods, startup, system settings, file operations, printing, how to paste smart objects, and other AP Editor operations.

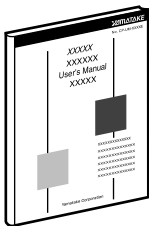

Smart Terminal EST240Z User's Manual Smart Object Library Manual No. CP-SP-1089E

This manual.

Graphic elements that have functions for displaying on the EST240Z are called "smart objects."

This manual describes the concept of smart objects and the functions of each smart object.

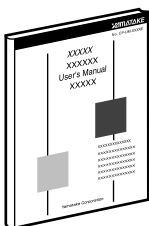

Smart Terminal EST240Z User's Manual Communications Connection Manual No. CP-SP-1090E

This manual should be read by those who combine the EST240Z with PLCs made by other manufacturers and dedicated board computers to build systems. This manual describes how to connect to PLCs, address maps that correspond to PLCs, how to paste smart objects, drawing, and other operations and settings required for making applications using PLCs.

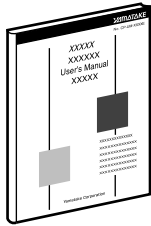

**Smart Terminal EST240Z User's Manual
DMC10 Package**

Manual No. CP-SP-1091E

This package is used when constructing systems by connecting the EST240Z to Yamatake's Distributed Multi-channel Controller DMC10.

This manual describes the specifications of the software package, how to use the package, how to install the software, and how to operate the software.

Organization of This User's Manual

This manual is organized as follows.

Chapter 1. SMART OBJECT LIBRARY CONFIGURATION

This chapter describes what a “smart object” is, the configuration of the smart object library, categories and lists of smart objects, a list of panels already provided in the system and their functions. Before using smart objects, understand the concept of smart objects.

Chapter 2. SMART OBJECT SPECIFICATIONS

This chapter describes the conventions used in the smart object specifications in chapters 3, 4 and 5, and the main setting items of smart objects.

Chapter 3. BASIC SMART OBJECTS

This chapter describes the functions, parameters and cautions when using each of the smart objects.
Use this chapter to reference the specifications of relevant smart objects when using smart objects.

Chapter 4. INSTRUMENTATION SMART OBJECTS

This chapter describes the functions, parameters and cautions when using each of the instrumentation smart objects.
Use this chapter to reference the specifications of relevant smart objects when using instrumentation smart objects.

Chapter 5. SYSTEM PANELS

General-purpose frequently used screens such as numeric keypads and keyboards are already provided in the system as system panels.
This chapter describes the functions of each system panel, examples of how system panels are used, and the external dimensions of system panels.

Appendix LIST OF SMART OBJECT GRAPHICS

This Appendix lists the graphic elements that are included in the smart object library.
Use this list as an index when you need to search a smart object.

Contents

The Role of This Manual	
Organization of This User's Manual	
Conventions Used in This Manual	

Chapter 1. SMART OBJECT LIBRARY CONFIGURATION

1-1 Library Configuration.....	1-1
■ Smart Objects.....	1-1
■ Smart Object Library.....	1-2
1-2 Classification of Smart Object Types.....	1-3
■ Basic Smart Objects.....	1-3
■ Instrumentation Smart Objects.....	1-4
1-3 List of Smart Objects.....	1-5
■ List of Basic Smart Objects.....	1-5
■ List of Instrumentation Smart Objects.....	1-6
1-4 List of Smart Object Sizes.....	1-7
■ Basic Smart Objects.....	1-7
■ Instrumentation Smart Objects.....	1-9

Chapter 2. SMART OBJECT SPECIFICATIONS

2-1 Conventions Used in Smart Object Specifications.....	2-1
■ Basic Layout of Specification Descriptions.....	2-1
■ Name and Attributes of Smart Object.....	2-2
■ Function.....	2-2
■ Settings.....	2-2
■ Examples.....	2-2
■ Smart Object Parameters.....	2-3
■ Supplementary Explanation.....	2-4
2-2 Main Configuration Items for Smart Objects.....	2-5
■ Smart Object Properties.....	2-5
■ Basic.....	2-6
■ Graphic.....	2-7
■ Text.....	2-9
■ Interlock.....	2-10
■ Switch Communications.....	2-13

Chapter 3. BASIC SMART OBJECTS

3-1 Switches.....	3-1
Switch.....	3-1
3-2 Function Switches.....	3-5
Radio switch.....	3-5
Inching.....	3-8
Clock setting call.....	3-11
Alarm silence.....	3-14
3-3 Word Type Switches.....	3-17
Word data write.....	3-17
Constant write.....	3-20
Data calculation.....	3-23

3-4	Panel Change Switches	3-27
	Panel change switch, panel selector	3-27
	Panel change switch, panel overlay	3-29
	Panel change switch, open pop-up	3-31
	Panel change switch, special package selector	3-34
	Panel change switch, multi-panel selector (others)	3-36
	Panel change switch, multi-panel overlay (others)	3-39
	Panel change switch, background panel selector (others)	3-42
	Panel change switch, background panel close (others)	3-44
	Panel change switch, panel selector (background change menu) (others)	3-46
	Panel change switch, panel selector (background close) (others)	3-48
	Panel change switch, panel close (others)	3-50
	Panel change switch, panel replace (others)	3-52
	Panel change switch, panel to front (others)	3-54
	External, panel selector	3-56
	External, panel overlay	3-59
	External, open pop-up	3-62
	External, special package selector	3-64
	External, multi-panel selector (others)	3-66
	External, multi-panel overlay (others)	3-68
	External, background panel selector (others)	3-7
	External, background panel close (others)	3-72
	External, panel selector (background change menu) (others)	3-74
	External, panel selector (background close) (others)	3-76
	External, panel close (others)	3-78
3-5	Lamps	3-81
	Bit type 2-state lamp	3-81
	Bit type 3-state lamp	3-83
	Bit type multi-value state lamp	3-86
	Word type 2-state lamp	3-88
	Word type 3-state lamp	3-91
	Word type multi-value state lamp	3-94
3-6	Numeric Indicators	3-97
	Basic	3-97
	With calculation	3-104
3-7	Graphs/Meters	3-113
	Bar graph	3-113
	Meter	3-117
	Slide meter	3-120
	Pie-chart	3-123
	Line graph	3-125
3-8	Text Display	3-129
	Registered string data	3-129
	Variable string data	3-132
	Message call	3-138
3-9	Keyboard Call	3-141
	Numeric keypad	3-141
	Keyboard	3-147

3-10 Data Setter	3-151
Password numeric keypad	3-151
UP/DOWN setter	3-153
Bit pattern setter	3-156
3-11 Alarm Monitor	3-159
Aggregation lamp (alarm lamp)	3-159
Representative lamp (alarm lamp)	3-163
Alarm buzzer	3-166
Monitor start/stop	3-168
Summary display (alarm information display)	3-171
History display (alarm information display)	3-174
Number of occurrence display (alarm information display)	3-177
Alarm information clear	3-180
3-12 Clock	3-183
Digital clock	3-183
Analog clock	3-185
Digital calendar	3-187
External clock adjustment	3-189
3-13 State Control	3-191
External backlight control	3-191
External backlight ON	3-193
External buzzer control	3-195
External buzzer OFF	3-197
Battery alarm notification	3-199
Data write when opening the panel	3-201

Chapter 4. INSTRUMENTATION SMART OBJECTS

4-1 PID controller	4-1
SDC10	4-1
SDC20/21	4-4
SDC30/31	4-7
SDC40A (standard/remote SP type)	4-10
DMC10 (2 channel model)	4-13
DMC10 (4 channel model)	4-17
CB508	4-21
4-2 Recipe	4-2
■ Recipe Write Methods	4-26
■ Recipe Settings	4-27
■ Area Required for Recipe Functions	4-27
■ Recipe Data	4-28
■ Recipe Smart Objects	4-28
■ Recipe Selection Panel	4-30
■ Recipe Edit Panel	4-31
■ Operation of Manual Write Smart Objects	4-32
■ Operation of Auto Write Smart Objects	4-33
Manual write	4-34
Auto write	4-38
4-3 Trend	4-43

■ Trend Buffers	4-43
■ Trend Displays	4-44
■ Trend Menu Panel	4-45
■ Variable Trend Menu Panels	4-46
Trend	4-48
Variable trend	4-56
4-4 Graphic Display	4-65
Rail movement	4-65
Free movement	4-67

Chapter 5. SYSTEM PANELS

5-1 Conventions Used In System Panel Specifications	5-1
■ System Panels	5-1
■ List of System Panels	5-1
■ Basic Layout of Specification Descriptions	5-2
■ Names of System Panel Types	5-3
■ Function	5-3
■ Example	5-3
■ Supplementary Explanation	5-3
■ Panel Shapes	5-3
5-2 Numeric Keypad	5-4
5-3 Keyboard	5-8
5-4 Clock Correction	5-10
5-5 Messages	5-12
5-6 Alarm Messages	5-14
5-7 Trend Menus	5-16
5-8 Recipe Menus	5-21
Recipe read panel	5-21
Recipe edit panel	5-23

Appendix LIST OF SMART OBJECT GRAPHICS

■ Switch and Lamp Graphics	A-2
■ Seesaw Switch Graphics	A-4
■ Slide Switch Graphics	A-5
■ Inching Switch Graphics	A-6
■ Border Graphics	A-7
■ Piping Graphics	A-11
■ Tank Graphics	A-11
■ Meter Graphics	A-11
■ Analog Clock Graphics	A-12
■ Numeric Keypad Graphic for Password Entry	A-12
■ UP/DOWN Setter Graphics	A-12
■ Alarm History Graphics	A-13
■ Alarm Summary Graphics	A-14
■ Alarm Count Display Graphics	A-15
■ SDC10 Graphics	A-16
■ SDC20/21 Graphics	A-16
■ SDC30/31 Graphics	A-16

■ SDC40A Graphics	A-17
■ DMC10 (2 channel model)	A-17
■ DMC10 (4 channel model)	A-18
■ CB508 Graphics	A-19
■ Trend Graphics	A-20
■ Recipe Graphics	A-28

Conventions Used in This Manual

The following conventions are used in this manual.



Handling Precautions

: Handling Precautions indicate items that the user should pay attention to when handling the **EST240Z**.



Note

: Notes indicate useful information that the user might benefit by knowing.

Chapter 1. SMART OBJECT LIBRARY CONFIGURATION

1 - 1 Library Configuration

■ Smart Objects

The application data is the data created to operate the smart terminal EST series. The panel data in the application data consists of the following elements:

- Points
- Straight lines
- Rectangles
- Circles and ellipses
- Circle and ellipse arcs
- Strings
- Paint
- Background color
- Bitmaps, JPEG image data
- Smart objects

Screens (panels) can be designed by using smart objects in a similar manner to the way conventional switches and meters are installed and wired in an instrumentation panel. Graphics and software including switch functions, operations, and communications functions are encapsulated in smart objects. This greatly reduces the number of design man-hours.

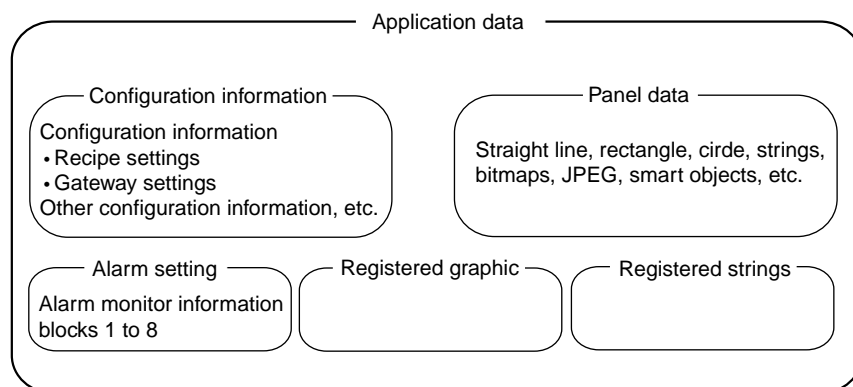

■ Smart Object Library

The smart object library is like a catalog that shows the list of the smart objects. When creating panel data, create a still image first in the panel, and then select the desired parts from the smart object library, and paste them in the panel. The smart object library is divided into a basic smart object library and an instrumentation smart object library according to your specific requirements.

● Basic smart object library

These smart objects are required for creating basic operation panels.

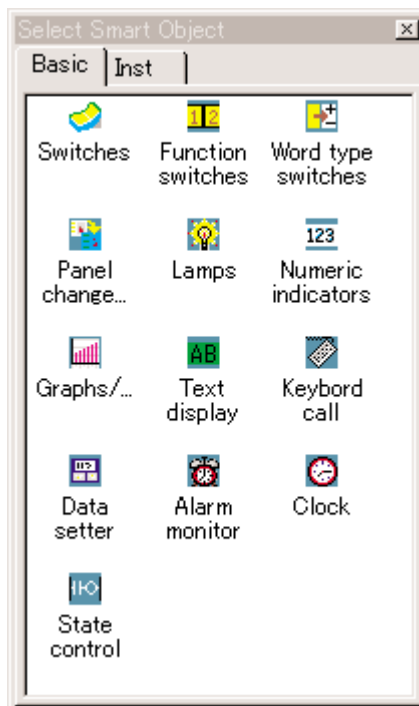

● Instrumentation smart object library

This library groups together smart objects required for creating various instrumentation applications.

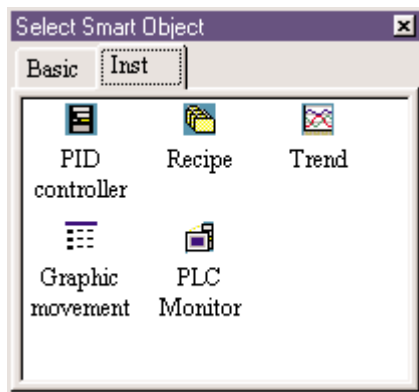

1 - 2 Classification of Smart Object Types

There are two types of smart objects, basic smart objects and instrumentation smart objects.

■ Basic Smart Objects

The basic smart object library contains the following smart objects:

- **Switches**

These smart objects turn the bits of the PLC ON and OFF.

- **Function switches**

These smart objects are radio switches and switch smart objects with functions such as buzzer stop.

- **Word type switches**

These switch smart objects have functions for setting data to the register area.

- **Panel change switches**

These switch smart objects switch panel displays.

- **Lamps**

These smart objects display the ON/OFF state of the PLC bits.

- **Numeric indicators**

These smart objects display the numeric values of the PLC register data.

These smart objects also have functions for calling up numeric keypads when a numeric value field is touched.

- **Graphs/meters**

These smart objects display the PLC data as graphs or meters.

Graphs/meters include bar graphs, trend graphs, broken line graphs, and meters.

- **Text display**

These smart objects display names of nameplates and messages.

- **Keyboard call**

These switch smart objects call up numeric keypads or keyboards.

- **Data setter**

These smart objects change the PLC data.

Data setters include smart objects for setting numeric values by the UP/DOWN keys, bit setters, and numeric keypads for entering passwords.

- **Alarm monitor**

These smart objects display the state of the alarm contacts defined in the alarm monitor information.

Alarm monitors include aggregate displays and history displays.

- **Clock**

These smart objects display the date/time of the EST's internal clock.

- **State control**

These smart objects include smart objects for controlling the EST backlight and buzzer, notifying the battery alarm, and writing constants to the PLC when the panel is opened.

■ Instrumentation Smart Objects

The instrumentation smart object library contains the following smart objects:

- **PID controller**

These smart objects enable monitoring of the SP and PV, etc. of the Yamatake temperature controllers.

- **Recipe**

These smart objects are for batch management and changing data to be set to the PLC or Yamatake temperature controllers.

- **Trend**

These smart objects are for sampling and saving the data of up 55 channels (8-trend channels x 5, 3-event channels x 5) and displays the sampled data as trends. The device on which trends are to be sampled and the sampling cycle can be also be changed on the EST.

- **Graphic movement**

These smart objects are for displaying movement of registered graphics.

1 - 3 List of Smart Objects

■ List of Basic Smart Objects

Smart object type	Smart object name	See page
Switches	Switch	3-1
Function switches	Radio switch	3-5
	Inching	3-8
	Clock adjustment	3-11
	Alarm silence	3-14
Word type switches	Word data write	3-17
	Constant write	3-20
	Data calculation	3-23
Panel change switches	Panel change switch, panel selector	3-27
	Panel change switch, panel overlay	3-29
	Panel change switch, open pop-up	3-31
	Panel change switch, special package selector	3-34
	Panel change switch, multi-panel selector [others]	3-36
	Panel change switch, multi-panel overlay [others]	3-39
	Panel change switch, background panel selector [others]	3-42
	Panel change switch, background panel close [others]	3-44
	Panel change switch, panel selector (background change menu) [others]	3-46
	Panel change switch, panel selector (background close) [others]	3-48
	Panel change switch, panel close [others]	3-50
	Panel change switch, panel replace [others]	3-52
	Panel change switch, panel to front [others]	3-54
	External, panel selector	3-56
	External, panel overlay	3-59
	External, open pop-up	3-62
	External, special package selector	3-64
	External, multi-panel selector [others]	3-66
	External, multi-panel overlay [others]	3-68
	External, background panel selector [others]	3-70
External, background panel close [others]	3-72	
External, panel selector (background change menu) [others]	3-74	
External, panel selector (background close) [others]	3-76	
External, panel close [others]	3-78	
Lamps	Bit type 2-state lamp	3-81
	Bit type 3-state lamp	3-83
	Bit type multi-value state lamp	3-86
	Word type 2-state lamp	3-88
	Word type 3-state lamp	3-91
	Word type multi-value state lamp	3-94
Numeric indicators	Basic	3-97
	With calculation	3-104
Graphs/meters	Bar graph	3-113
	Meter	3-117
	Slide meter	3-120
	Pie-chart	3-123
	Line graph	3-125
Text display	Registered string data	3-129
	Variable string data	3-132
	Message call	3-138
Keyboard call	Numeric keypad	3-141
	Keyboard	3-147
Data setter	Password numeric keypad	3-151
	UP/DOWN setter	3-153
	Bit pattern setter	3-156

Smart object type	Smart object name	See page
Alarm monitor	Aggregation display [alarm lamp]	3-159
	Representative lamp [alarm lamp]	3-163
	Alarm buzzer	3-166
	Monitor start/stop	3-168
	Summary display [alarm information display]	3-171
	History display [alarm information display]	3-174
	Number of occurrence display [alarm information display]	3-177
	Alarm information clear	3-180
Clock	Digital clock	3-183
	Analog clock	3-185
	Digital calendar	3-187
	External clock adjustment	3-189
State control	External backlight control	3-191
	External backlight ON	3-193
	External buzzer control	3-195
	External buzzer OFF	3-197
	Battery alarm notification	3-199
	Data write when opening the panel	3-201

■ List of Instrumentation Smart Objects

Smart object type	Smart object name	See page
PID controller	SDC10	4-1
	SDC20/21	4-4
	SDC30/31	4-7
	SDC40A (standard/remote SP type)	4-10
	DMC10 (2 channel model)	4-13
	DMC10 (4 channel model)	4-17
	CB508	4-21
Recipe	Manual write	4-34
	Auto write	4-38
Trend	Trend	4-48
	Variable trend	4-56
Graphic movement	Rail movement	4-65
	Free movement	4-67

1 - 4 List of Smart Object Sizes

This list indicates the basic size of each smart object.

When a smart object is pasted on a panel, the smart object is pasted at its basic size.

The size of scalable smart objects can be changed after they have been pasted at their basic size.

■ Basic Smart Objects

Smart object type	Smart object name	Basic size (dots)	Scaling
Switches	Switch	40 x 40	○
Function switches	Radio switch: 2 items	80 x 40	○
	Radio switch: 3 items	120 x 40	○
	Radio switch: 4 items	160 x 40	○
	Inching: Horizontal	80 x 40	
	Inching: Vertical	40 x 80	
	Inching: 4-way	120 x 120	
	Inching: 8-way	120 x 120	
	Clock adjustment	40 x 40	○
	Alarm silence	40 x 40	○
Word type switches	Word data write	40 x 40	○
	Constant write	40 x 40	○
	Data calculation	40 x 40	○
Panel change switches	Panel change switch, panel selector	40 x 40	○
	Panel change switch, panel overlay	40 x 40	○
	Panel change switch, open pop-up	40 x 40	○
	Panel change switch, special package selector	40 x 40	○
	Panel change switch, multi-panel selector [others]	40 x 40	○
	Panel change switch, multi-panel overlay [others]	40 x 40	○
	Panel change switch, background panel selector [others]	40 x 40	○
	Panel change switch, background panel close [others]	40 x 40	○
	Panel change switch, panel selector (background change menu) [others]	40 x 40	○
	Panel change switch, panel selector (background close) [others]	40 x 40	○
	Panel change switch, panel close [others]	40 x 40	○
	Panel change switch, panel replace [others]	40 x 40	○
	Panel change switch, panel to front [others]	40 x 40	○
	External, panel selector	40 x 40	
	External, panel overlay	40 x 40	
	External, open pop-up	40 x 40	
	External, special package selector	40 x 40	
	External, multi-panel selector [others]	40 x 40	
	External, multi-panel overlay [others]	40 x 40	
	External, background panel selector [others]	40 x 40	
	External, background panel close [others]	40 x 40	
	External, panel selector (background change menu) [others]	40 x 40	
	External, panel selector (background close) [others]	40 x 40	
External, panel close [others]	40 x 40		
Lamps	Bit type 2-state lamp	40 x 40	○
	Bit type 3-state lamp	40 x 40	○
	Bit type multi-value state lamp	40 x 40	
	Word type 2-state lamp	40 x 40	○
	Word type 3-state lamp	40 x 40	○
	Word type multi-value state lamp	40 x 40	

Chapter 1. SMART OBJECT LIBRARY CONFIGURATION

Smart object type	Smart object name	Basic size (dots)	Scaling
Numeric indicators	Basic: 1-digit	20 x 20	○
	Basic: 2-digit	28 x 20	○
	Basic: 3-digit	36 x 20	○
	Basic: 4-digit	44 x 20	○
	Basic: 5-digit	52 x 20	○
	Basic: 6-digit	60 x 20	○
	Basic: 7-digit	68 x 20	○
	Basic: 8-digit	76 x 20	○
	Basic: 9-digit	84 x 20	○
	Basic: 10-digit	92 x 20	○
	Basic: 11-digit	100 x 20	○
	With calculation: 1-digit	20 x 20	○
	With calculation: 2-digit	28 x 20	○
	With calculation: 3-digit	36 x 20	○
	With calculation: 4-digit	44 x 20	○
	With calculation: 5-digit	52 x 20	○
	With calculation: 6-digit	60 x 20	○
	With calculation: 7-digit	68 x 20	○
	With calculation: 8-digit	76 x 20	○
	With calculation: 9-digit	84 x 20	○
With calculation: 10-digit	92 x 20	○	
With calculation: 11-digit	100 x 20	○	
Graphs/meters	Bar graph: Vertical	20 x 40	○
	Bar graph: Horizontal	40 x 20	○
	Bar graph: Tank type	30 x 30	○
	Meter: Upwards	180 x 100	○
	Meter: Downwards	180 x 100	○
	Meter: Rightwards	100 x 180	○
	Meter: Leftwards	100 x 180	○
	Slide meter: Vertical	1 x 100	○
	Slide meter: Horizontal	100 x 1	○
	Pie-chart	40 x 40	○
	Line graph	80 x 80	○
Text display	Registered string data	68 x 20	○
	Variable string data	68 x 20	○
	Message call	40 x 40	○
Keyboard call	Numeric keypad	40 x 40	○
	Keyboard	40 x 40	○
Data setter	Password numeric keypad	160 x 200	○
	UP/DOWN setter	80 x 40	○
	Bit pattern setter	320 x 40	○
Alarm monitor	Aggregation display [alarm lamp]: 8-point	320 x 40	○
	Aggregation display [alarm lamp]: 5-point	200 x 40	○
	Aggregation display [alarm lamp]: 4-point	160 x 40	○
	Aggregation display [alarm lamp]: 1-point	40 x 40	○
	Representative lamp [alarm lamp]	40 x 40	○
	Alarm buzzer	40 x 40	○
	Monitor start/stop	40 x 40	○
	Summary display [alarm information display]	320 x 180	○
	History display [alarm information display]	320 x 160	○
	Number of occurrence display [alarm information display]	320 x 160	○
Alarm information clear	40 x 40	○	

Smart object type	Smart object name	Basic size (dots)	Scaling
Clock	Digital clock: 24hours	76 x 20	○
	Digital clock: 12hours	92 x 20	○
	Analog clock	80 x 80	○
	Digital calendar	116 x 20	○
	External clock adjustment	40 x 40	
State control	External backlight control	40 x 40	
	External backlight ON	40 x 40	
	External buzzer control	40 x 40	
	External buzzer OFF	40 x 40	
	Battery alarm notification	40 x 40	
	Data write when opening the panel	40 x 40	

■ Instrumentation Smart Objects

Smart object type	Smart object name	Basic size (dots)	Scaling
PID controller	SDC10	80 x 160	
	SDC20/21	80 x 200	
	SDC30/31	80 x 200	
	SDC40A (standard/remote SP type)	80 x 200	
	DMC10 (2 channel model)	320 x 200	
	DMC10 (4 channel model)	320 x 200	
	CB508	320 x 200	
Recipe	Manual write	320 x 200	
	Manual write (with message)	320 x 220	
	Auto write	320 x 200	
	Auto write (with message)	320 x 200	
Trend	Trend	320 x 240	
	Variable trend	320 x 240	
Graphic movement	Rail movement: Vertical	1 x 221	○
	Rail movement: Horizontal	221 x 1	○
	Free movement	40 x 40	

Chapter 2. SMART OBJECT SPECIFICATIONS

2 - 1 Conventions Used in Smart Object Specifications

Basic Layout of Specification Descriptions

The conventions shown below are used in descriptions of specifications of each smart object.

The following pages describe each of the items in these specification descriptions:

Chapter 3. BASIC SMART OBJECTS

3 - 1 Switches

Smart object name	Switch
Type	Switches

Scaling					Paste coordinates
Enlarge	Reduce	Reshape	Scaling factor	Text size	
<input type="radio"/>	<input type="radio"/>	<input type="radio"/>	Any	Fixed	Any

Function

- This smart object manipulates switch devices in the PLC via the touch switches.

Configuration

- Basic

Example

[Momentary switch]
Switch device = M000, lamp device = M001

Smart Object Parameters

Parameter type	Parameter name	Selection/setting item	Remarks
Basic	Switch operation	Select switch action from momentary/alternate/bit set/bit reset.	
	Switch device	Enter the communications channel, the station address, and the bit device.	
	Lamp device	Enter the communications channel, the station address, and the bit device.	
	Hide device	Enter the communications channel, the station address, and the bit device.	When lamp devices are used
	SW comm	Select when using switch communications.	
	Interlock	Select when using interlocked operation.	

3-1

Name and attributes of the smart object

Functions

Configuration

Example

Smart object parameters

Supplementary Explanation

- Select OFF Graphic for the graphic selection when a lamp device is used. OFF Graphic is paired with ON Graphic and is automatically selected. Note, however, that OFF Graphic/ON Graphic can be freely selected when "User" has been selected at Graphic type.

Handling Precautions

- Enter the bit device on the PLC for the Switch/Lamp/Hide device. Do not enter word devices such as registers.

Supplementary explanation

■ Name and Properties of Smart Objects

● Smart object name

This shows the name of the smart object.

● Type

This shows the group to which the smart object belongs.

● Scaling

This shows whether or not smart objects can be scaled (enlarged/reduced) and scaling limits when pasting the smart objects.

[Enlarge] → When a smart object can be enlarged, this is indicated by ○. The indication is blank when the smart object cannot be enlarged.

[Reduce] → When a smart object can be reduced, this is indicated by ○. The indication is blank when the smart object cannot be reduced.

[Reshape] → When a smart object can be scaled in the horizontal and vertical directions independently, this is indicated by ○. This indication is blank when the smart object cannot be transformed.

[Scaling factor] → The scaling factor indicates the limits to which a smart object can be scaled. Smart objects that cannot be scaled are indicated by a “—”.

[Integer multiple]Scaling of smart objects is limited to enlargement in integer multiples.

[Any]Smart objects can be scaled using any scaling factor.

● Text size

There are two text size options, “Interlocked” and “Fixed”.

Smart objects that do not have text or numeric values are indicated by “—”.

[Interlocked] → The size of text or numeric values is also scaled when the smart object is scaled.

[Fixed] → The size of text or numeric values is fixed when the smart object is scaled.

● Paste coordinates

[Any] → Smart objects can be pasted to any position.

■ Function

This item describes the functions of the smart object.

■ Configuration

This item describes the setting unique to the smart object.

■ Examples

This item provides examples of how the smart object operates using certain settings as an example.

Smart Object Parameters

Smart object parameters are setting items that are required for operating the smart object. For example, parameters include the device address of the PLC to which a switch is assigned, and the text that is to be displayed on the switch. Smart object parameters are set when pasting smart objects.

This section describes the contents of each smart object parameter and its setting ranges.

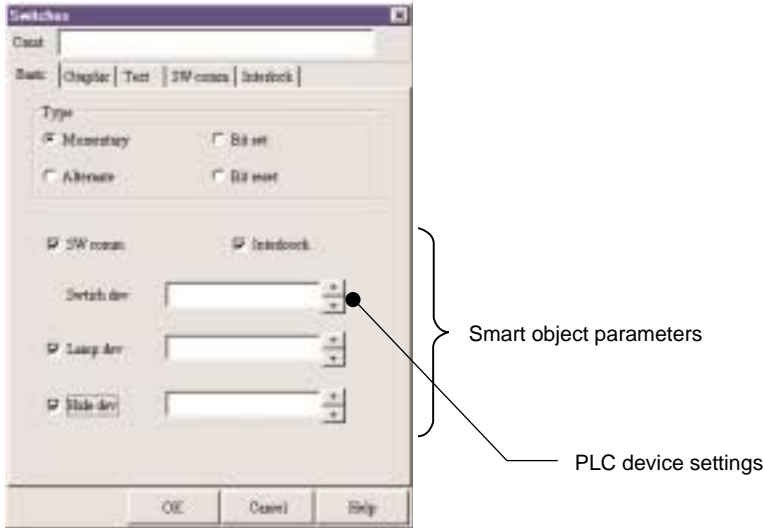

Setting of the PLC device

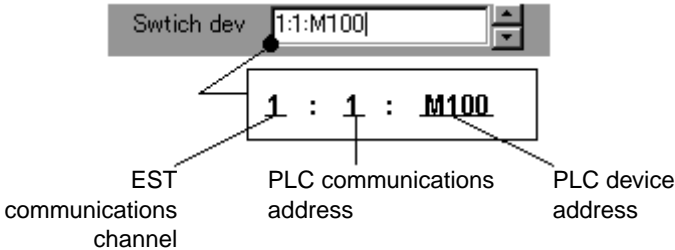

EST communications channel

Specify which channel, from channels 0 to 4, to use for executing communications. The communications settings in the basic settings in the setup information must be set in AP Editor.

When only one target communications channel is set, the channel can be omitted and the device set as follows:

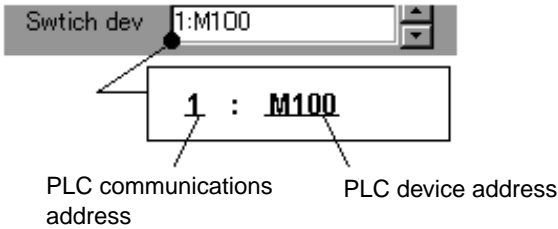

For details on the EST communications channel, refer to the Smart Terminal EST240Z User's Manual Communications Connection Manual No.CP-SP-1090E.

- **PLC communications address**
Set the communications address of the destination PLC in decimal. Setting ranges and other information differ according to the PLC. Be sure to set the same communications address as that of the PLC.
- **PLC device**
Specify the word device or bit device of the PLC.
Conventions used differ according to PLC type and device.
For details, refer to the Smart Terminal EST240Z User's Manual Communications Connection Manual No.CP-SP-1090E. If the PLC type is not set in the communications settings, an input error will occur, and the PLC device cannot be entered.

■ **Supplementary Explanation**

This item provides supplementary explanations regarding functions and smart object parameters.

Handling Precautions

Handling Precautions indicate items that the user should pay attention to when handling the Smart Terminal.

2 - 2 Main Configuration Items for Smart Objects

■ Smart Object Properties

Smart object properties are ocnfiguration items that are required for operation of the smart object.

Smart objects operate according to the parameters that are set to the smart object properties.

Smart object properties are categorized by tab according to their content.

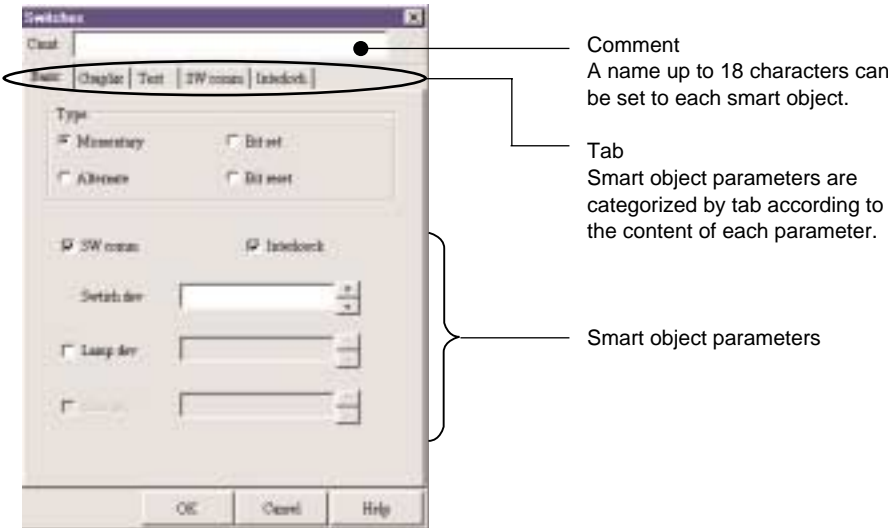

■ Basic

This sheet is for setting basic operation of each smart object.
 The content of smart object parameters that are set on the Basic sheet differs according to the smart object. Settings are described in detail for each smart object.

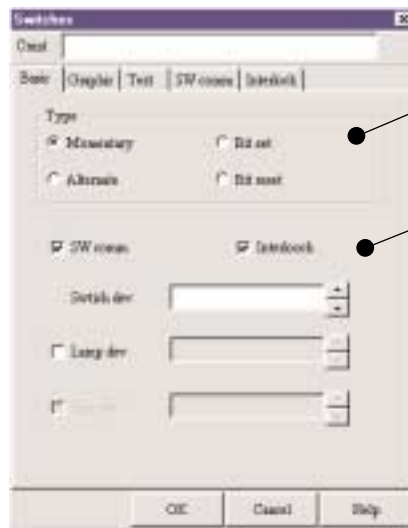

- [Type]
This item is for selecting the operation type of the smart object.
- [Functions]
This item is for adding smart object functions. By selecting a selection item, the selected item is enabled, and a tab for setting that function is added.
- [Device settings]
This item is for setting the PLC device that is to be targeted for operation of the smart object.

● Setting of the PLC device

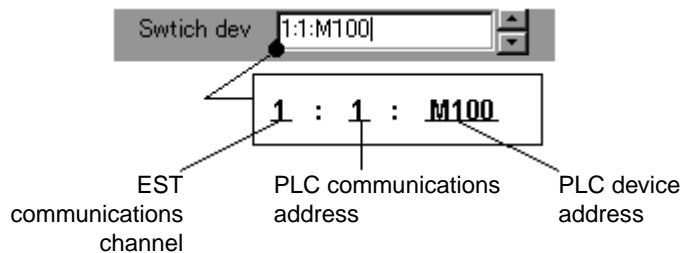

- EST communications channel
Specify which channel, from channels 0 to 4, to use for executing communications. The communications settings in the basic settings in the setup information must be set in AP Editor.
When only one target communications channel is set, the channel can be omitted and the device set as follows:

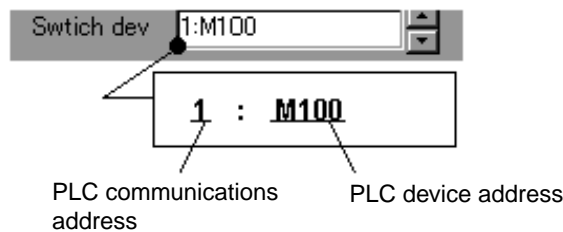

For details on the EST communications channel, refer to the Smart Terminal EST240Z User's Manual Communications Connection Manual No.CP-SP-1090E.

■ Graphic

This sheet is for selecting graphics to be displayed on the smart object.

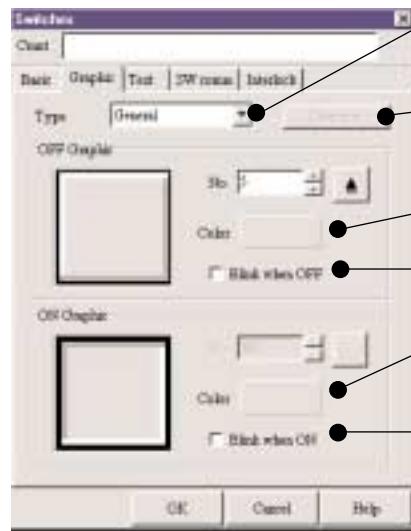

[Type]

This item is for selecting the type of graphic to be displayed on the smart object.

[Common]

This item is for setting graphic at ON to the same graphic as graphic at OFF.

[OFF Graphic]

This item is for setting the display graphic at the OFF state.
The fill color of the graphic can also be set here.

[ON Graphic]

This item is for setting the display graphic at the ON state.
The ON graphic setting is not available for smart objects that do not have a graphic switching function for when the ON/OFF state changes.

[Blink]

You can specify blinking at the ON/OFF states on smart objects that have a graphic switching function for when the ON/OFF state changes.

● Type

Select the type of graphic to be displayed on the smart object from the following options:

- General: This is the basic graphic that is already provided in the library.
- Rocker: This is the graphic of a rocker switch.
- Slide: This is the graphic of a slide switch.
- Piping lamp: This is the graphic for displaying piping.
- User: Select this to use a graphic that has been registered to a registered graphic.

● Common

Set the ON graphic to the same graphic as the OFF graphic.

The Common button can be used only when 3-state lamp smart objects, or graphic type has been set to "User".

● Graphic

Select the graphic to be displayed.

The number of graphics that can be selected differs according to the smart object to be used.

- Graphic: Sets the display graphic of the smart object.
- OFF/ON Graphic: Set the graphic in the OFF or ON states for smart objects that have a function for switching the graphic for the smart object according to the lamp bit or smart object state.
- States 1/2/3: The graphic of each state can be specified for 3-state lamp smart objects.

● **Color**

Change the display color of the graphic.

Note, however, that the fill color cannot be changed when the graphic type has been selected to "User".

● **Blink**

Specify the blink operation.

Blink operation can be specified on smart objects that have a graphic switching function.

When blink is selected, the ON and OFF graphics are alternately displayed.

The blink interval setting can be changed in the General Configuration Information using the AP Editor and with the System screen of the EST unit.

■ Text

● Display format

This sheet is for configuration strings that are to be displayed on smart objects.

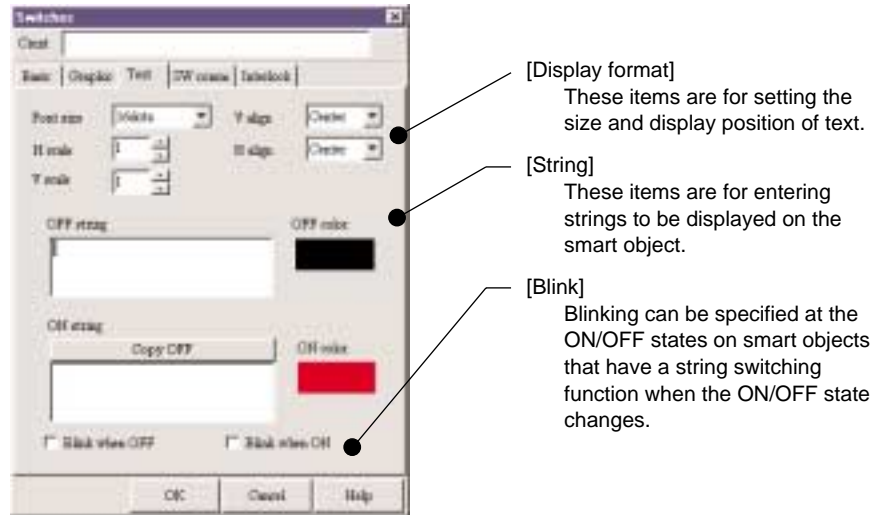

[Display format]

These items are for setting the size and display position of text.

[String]

These items are for entering strings to be displayed on the smart object.

[Blink]

Blinking can be specified at the ON/OFF states on smart objects that have a string switching function when the ON/OFF state changes.

Set the size and display position of the string to be displayed.

- Font size: Select from 8 dots/16 dots.
- H/V scale: Select the display scale of the string from 1 to 8X.
- V alignment: Select the vertical display position of the string from Top /Center/Bottom alignment.
- H alignment: Select the horizontal display position of the string from Left alignment/Center/Right alignment.

● String

Set the string and string color to be displayed on the smart object.

The number of setting items in the string setting changes according to the function of the smart object.

● Blink

Specify the blink operation.

Blink operation can be specified on smart objects that have a string display switching function.

When blink is selected, the ON and OFF string colors are alternately displayed.

The blink interval setting can be changed in the General Configuration Information using the AP Editor and with the System screen of the EST unit.

■ Interlock

Select “Use interlock” when assigning conditions to touch switch input.
Two interlock conditions are available, “Bit state” and “Range” judgment.

[Bit state]

Input on touch switches is controlled (enabled/disabled) by the ON/OFF state of the bit device that is specified as the interlock device.

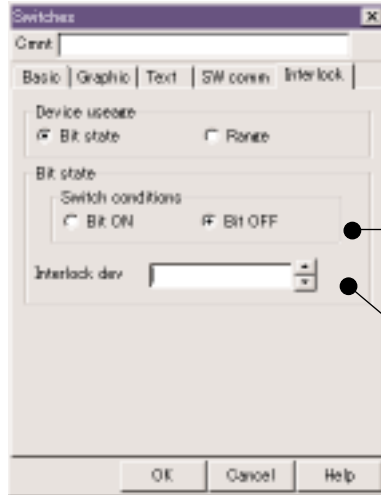

[Switch enable conditions]
This item is for selecting the conditions (ON/OFF state of the interlock device) for enabling input on touch switches.

[Interlock device]
This item is for entering the bit device.

● Switch enable condition

Select the condition for enabling touch switch input conditions inside the smart object:

- Bit ON: Enables input on touch switches when the state of the bit device that is specified as the interlock device is ON.
- Bit OFF: Enables input on touch switches when the state of the bit device that is specified as the interlock device is OFF.

● Interlock device

Enter the bit device on the PLC by which interlock control is to be controlled.

[Range]

Input on touch switches is controlled (enabled/disabled) by the data value of the word device that is specified as the interlock device.

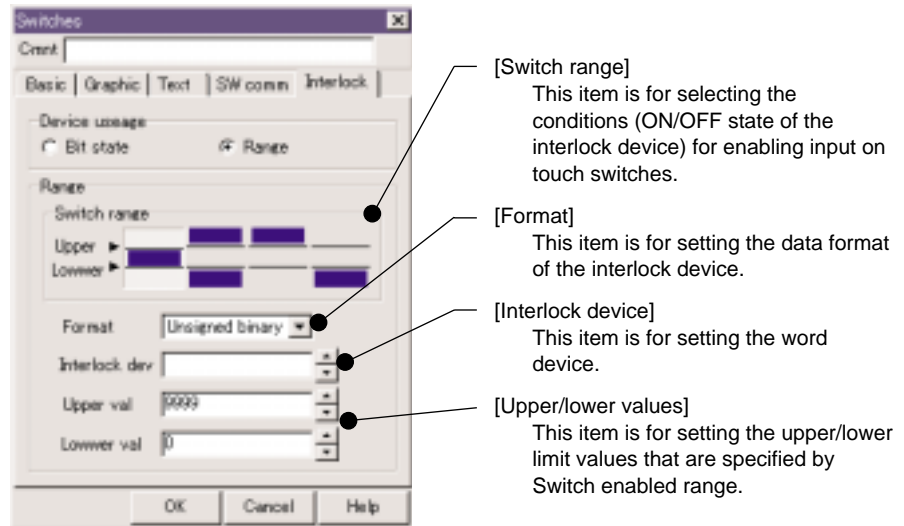

● **Switch range**

Select the conditions (data range of the interlock device) for enabling touch switch input conditions inside the smart object:

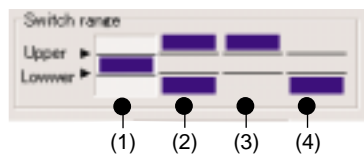

Switch enabled ranges

- (1) Upper limit value ≥ Data of interlock device ≥ Lower limit value
- (2) Data of interlock device ≥ Upper limit value
or Data of interlock device ≤ Lower limit value
- (3) Data of interlock device ≥ Upper limit value
- (4) Data of interlock device ≤ Lower limit value

● **Format**

Select the data format of the interlock device from Unsigned binary/Signed binary/Hex/BCD.

● **Interlock device**

Enter the word device on the PLC by which interlock control is to be controlled.

● **Upper/lower values**

Enter the upper/lower limit values of the data that is specified by Switch enabled range.

The PLC device can also be entered to the upper/lower limit values.

● Example

Case: Momentary switch, switch device = M000, bit state judgment, switch enabled condition = bit ON, interlock device = M100

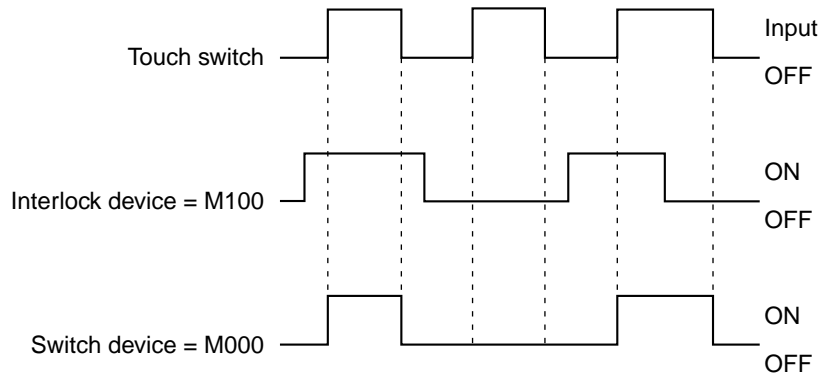

When the interlock device is enabled at touch switch input, the switch device is turned ON. However, the switch device will not turn ON when the interlock device is disabled.

In the case of a momentary switch, the switch device is reset to OFF if the interlock device is enabled at touch switch input even if the interlock device is disabled when the touch switch is deactivated.

■ Switch Communications

This sheet is for setting the switch communications functions when switch communications is used.

Switch communications is a function for notifying an external device (host computer, etc.) that an input operation was performed on a switch on the EST. In switch communications, the EST functions as a slave device. An advantage of switch communications is that it reduces the program load on the external device. Switch communications is not used when the device to which the EST is connected is a PLC.

There are two types of switch communications functions, input notification and completion notification. With input notification, notification is executed at input on a touch switch such as a smart object. With completion notification, notification is executed when setting of data is completed, for example, on a numeric keypad call smart object.

[Input notification]

This item executes switch notification operation at input on a touch switch.



[Switch code]
This item is for setting data within the range -32768 to +32767.

[Switch functions]
This item is for setting the operation functions in switch communications.

● Switch code

Set the switch code to be notified.
Set the data within the range -32768 to +32767.

● **Switch functions**

Set the function of switch communications from the following options:

- **Send at ON**

The switch code is issued by the serial command **Switch Notify (response only)[sw]** when the switch turns ON. The issued command is sent from the EST communications port currently set to “Serial slave station communications.”

- **Send at ON/OFF**

The switch code is issued by the serial command **Switch Notify (response only)[sw]** when the switch turns ON or OFF. The issued command is sent from the EST communications port currently set to “Serial slave station communications.”

- **Buffer at ON**

The switch code is written to the switch communications buffer when the switch turns ON.

When the switch code is written to the switch communications buffer, the switch output on the EST turns ON. For this reason, use the **Switch Communications Buffer Read[SW]** command to read the currently stored switch code when switch output has turned ON on the external device.

- **Buffer at ON/OFF**

The switch code is written to the switch communications buffer when the switch turns ON or OFF.

When the switch code is written to the switch communications buffer, the switch output on the EST turns ON. For this reason, use the **Switch Communications Buffer Read[SW]** command to read the currently stored switch code when switch output has turned ON on the external device.

For details on switch communications command, refer to the **Smart Terminal EST240Z User’s Manual Communications Connection Manual No.CP-SP-1090E**.

 **Handling Precautions**

Send at ON/OFF and Buffer at ON/OFF settings are not available for panel change smart objects.

[Completion notification]

This item executes switch notification operation at completion of a data setting operation.

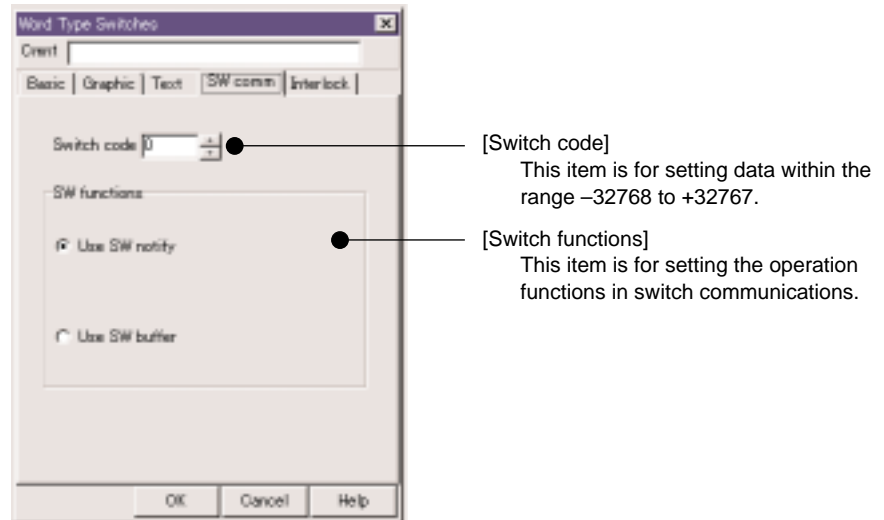

[Switch code]

This item is for setting data within the range -32768 to $+32767$.

[Switch functions]

This item is for setting the operation functions in switch communications.

- **Switch code**

Set the switch code to be notified.

Set the data within the range -32768 to $+32767$.

- **Switch functions**

Set the function of switch communications from the following options:

- **Use SW notify**

The switch code is issued by the serial command **Switch Notify (response only)[sw]** at completion of data setting. The issued command is sent from the EST communications port currently set to “Serial slave station communications.”

The event to be notified becomes “N”.

- **Use switch buffer**

The switch code is written to the switch communications buffer at completion of data setting.

When the switch code is written to the switch communications buffer, the switch output on the EST turns ON. For this reason, use the **Switch Communications Buffer Read[SW]** command to read the currently stored switch code when switch output has turned ON on the external device.

The event to be notified is “N”.

For details on switch communications command, refer to the **Smart Terminal EST240Z User’s Manual Communications Connection Manual No.CP-SP-1090E**.

Chapter 3. BASIC SMART OBJECTS

3 - 1 Switches

Smart object name	Switch				
Type	Switches				
Scaling					Paste coordinates
Enlarge	Reduce	Reshape	Scaling factor	Text size	
○	○	○	Any	Fixed	Any

■ Function

- This smart object manipulates switch devices in the PLC via the touch switches.
- Switch graphics are changed according to the ON/OFF state of the lamp device in the PLC.

■ Configuration

● Basic

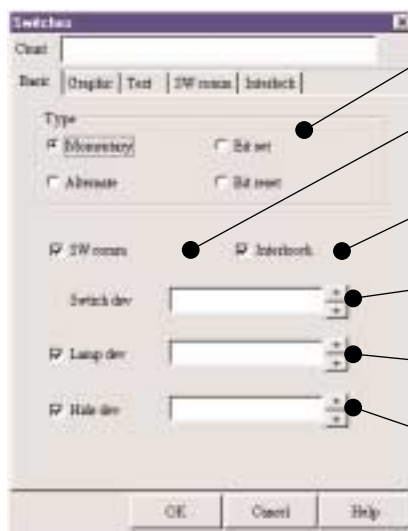

- [Type] This item is for selecting switch operation.
- [SW comm] Select this item when using switch communications functions.
- [Interlock] Select this item when using the interlock function.
- [Switch device] This item is for entering the bit device that is to be manipulated when a switch is touched.
- [Lamp device] This item is for entering the bit device to be monitored for switching graphic or text display.
- [Hide device] This item is for entering the bit device used to hide the graphic or text display.

- Type Select the operation of the switch when it is touched.

Momentary	PLC switch device turns ON for the time that this switch is held down.
Alternate	Each press of this switch switches the ON/OFF state of the PLC switch device.
Bit set	Pressing this switch sets the PLC switch device.
Bit reset	Pressing this switch resets the PLC switch device.

● Graphic

Set the switch graphic to be displayed on the smart object and the display color of the graphic.
When a lamp device is used, the graphic setting becomes OFF Graphic and ON Graphic.

● Text

Set the string to be displayed on the smart object and the display text color.
When a lamp device is used, the string setting becomes OFF String and ON String.

● **Switch Communications**

Set the operation of switch communications functions.

● **Interlock**

Set the entry enabled conditions for the switch.

■ **Example**

[Momentary switch]

Switch device = M000, lamp device = M001

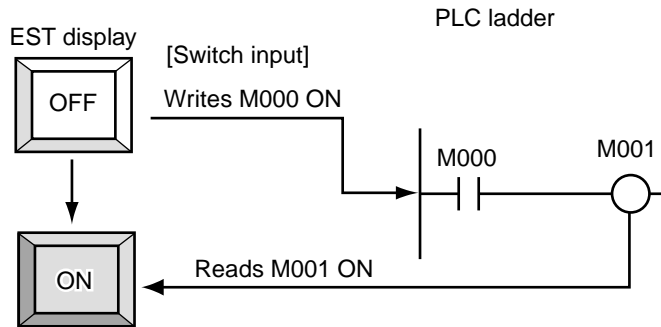

■ **Smart Object Parameters**

Parameter type	Parameter name	Selection/setting item	Remarks
Basic	Switch operation	Select switch action from momentary/alternate/bit set/bit reset.	
	Switch device	Enter the communications channel, the station address, and the bit device.	
	Lamp device	Enter the communications channel, the station address, and the bit device.	
	Hide device	Enter the communications channel, the station address, and the bit device.	When lamp devices are used
	SW comm	Select when using switch communications.	
	Interlock	Select when using interlocked operation.	
Graphic	Graphic type	Select the graphic type from general/rocker/slide/user.	
	OFF Graphic	Select the graphic displayed when OFF.	
	Color when OFF	Select the display color of the graphic when OFF.	
	Blink when OFF	Select to cause blinking when OFF.	
	ON Graphic	Select the display graphic when the lamp is ON.	When lamp devices are used
	Color when ON	Select the display color of the graphic when the lamp is ON.	When lamp devices are used
Text	Blink when ON	Select to cause blinking when the lamp is ON.	When lamp devices are used
	Font size	Select the font size from 8 and 16 dots.	
	V alignment	Select vertical alignment from top/center/bottom.	
	H alignment	Select horizontal alignment from left/center/right.	
	Horizontal scale	Enter the horizontal scale of the string.	1 to 8
	Vertical scale	Enter the vertical scale of the string.	1 to 8
	OFF string	Enter the display text when OFF.	
	OFF color	Enter the display text color when OFF.	
	Blink when OFF	Select to cause blinking when OFF.	When lamp devices are used
	ON string	Select the display text when the lamp is ON.	When lamp devices are used
	ON color	Select the display text color when the lamp is ON.	When lamp devices are used
Switch communications	Blink when ON	Select to cause blinking when the lamp is ON.	When lamp devices are used
	Switch code	Enter the switch code.	-32768 to +32767
Interlock	Switch communications function	Select the switch communications function.	
	Bit state	Interlock action according to ON/OFF state of bit device	
	Range	Interlock action according to bit device range	

■ Supplementary Explanation

- Select OFF Graphic for the graphic selection when a lamp device is used. OFF Graphic is paired with ON Graphic and is automatically selected. Note, however, that OFF Graphic/ON Graphic can be freely selected when “User” has been selected at Graphic type.
- The switch device and the lamp device may be the same.
- The hide device can be set when a lamp device is used.
- When the hide device is ON, the display of the switch graphic and the string will be hidden.
- For details on smart object settings, see “2-2 Main Configuration Items for Smart Objects” (page 2-5).

! Handling Precautions

- Enter the bit device on the PLC for the Switch/Lamp/Hide device. Do not enter word devices such as registers.
- When “User” is selected at Graphic type and registered graphics are used for the switch graphic, the OFF graphic and ON graphic to be displayed must be created at the same size.
- When “User” is selected at Graphic type and registered graphics are used for the switch graphic, the smart object size becomes the size of the graphic, and the smart object cannot be scaled.

3 - 2 Function Switches

Smart object name	Radio switch				
Type	Function switches				
Scaling					Paste coordinates
Enlarge	Reduce	Reshape	Scaling factor	Text size	
○	○	○	Any	Fixed	Any

■ Function

- With these smart objects, when one switch is touched only that switch turns ON; other switches turn OFF.
- Switch graphics are changed according to the ON/OFF state of the switch device in the PLC.

■ Configuration

● Basic

The screenshot shows the 'Function Switches' dialog box with the following settings and callouts:

- [Type]:** Points to the 'Radio switch' option in the 'Type' section.
- [SW comm]:** Points to the 'SW comm' checkbox, which is checked.
- [Interlock]:** Points to the 'Interlock' checkbox, which is checked.
- [Switch dev]:** Points to the 'Switch dev' text input field.
- [Used items]:** Points to the 'Used items' dropdown menu, which is set to '1 item'.

● Switch device

Enter the start bit device to be manipulated when a switch is touched. The smart object manipulates the number of bits set to Number of used items continuous from the start bit device.

● Graphic

Set the switch graphic to be displayed on the smart object and the display color of the graphic. The graphic setting becomes OFF Graphic and ON Graphic.

● Text

Set the string to be displayed on the smart object and the display text color. Set strings for the number of switches selected at "Used items."

● SW Communications

Set the operation of switch communications functions.

● Interlock

Set the entry enabled conditions for the switch.

■ Example

[3 radio switch array]

Switch device = M000, number of items used = 3

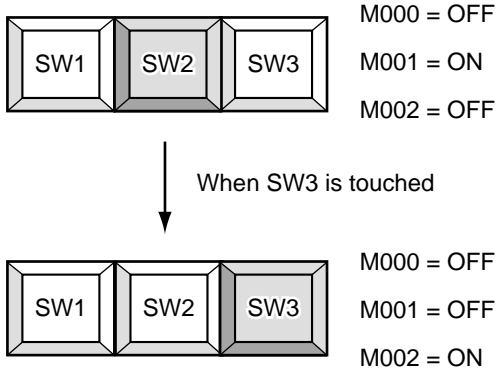

■ Smart Object Parameters

Tab name	Parameter name	Selection/setting item	Remarks
Basic	Switch device	Enter the communications channel, device address and bit device.	
	Used items	Select the number of radio switches.	2 to 4 items
	SW comm	Select when using switch communications.	
	Interlock	Select when using interlocked operation.	
Graphic	Type	Select general.	
	OFF Graphic	Select the graphic displayed at OFF.	
	Color when OFF	Select the display color of the OFF Graphic.	
	ON Graphic	Select the display ON Graphic.	
	Color when ON	Select the graphic display color when ON.	
Text	Font size	Select the font size from 8 and 16 dots.	
	V alignment	Select vertical alignment from top/center/bottom.	
	H alignment	Select horizontal alignment from left/center/right.	
	Horizontal scale	Enter the horizontal scale of the string.	1 to 8
	Vertical scale	Enter the vertical scale of the string.	1 to 8
	Item 1	Enter the display text of switch item 1.	
	Item 2	Enter the display text of switch item 2.	
	Item 3	Enter the display text of switch item 3.	When number of items used is set to 3 or 4
	Item 4	Enter the display text of switch item 4.	When number of items used is set to 4
	Color when OFF	Select the display text color when the switch device is OFF.	
ON color	Select the display text color when the switch device is ON.		
Switch communications	Code 1	Enter the switch code of switch item 1.	-32768 to +32767
	Code 2	Enter the switch code of switch item 2.	-32768 to +32767
	Code 3	Enter the switch code of switch item 3.	When number of items used is set to 3 or 4 -32768 to +32767
	Code 4	Enter the switch code of switch item 4.	When number of items used is set to 4 -32768 to +32767
	Switch communications function	Select the switch communications function.	
Interlock	Bit state	Interlock action according to ON/OFF state of bit device	
	Range	Interlock action according to bit device range	

■ Supplementary Explanation

- Switch items are arranged in order item 1, item 2, item 3 and item 4 from the left switch.
- The code setting in switch communications becomes code 1, code 2, code 3 and code 4 from the left switch.
- Select the OFF graphic for the graphic selection. The OFF graphic is paired with the ON graphic and is automatically selected.
- For details on smart object settings, see “2-2 Main Configuration Items for Smart Objects” (page 2-5).

❗ Handling Precautions

- Enter the bit device on the PLC for the Switch device. Do not enter word devices such as registers.
- “User” cannot be selected at Graphic type.

Smart object name	Inching				
Type	Function switches				
	Scaling				Paste coordinates
	Enlarge	Reduce	Reshape	Scaling factor	Text size
	—	—	—	—	—
					Any

■ Function

- This smart object manipulates inching.

■ Configuration

● Basic

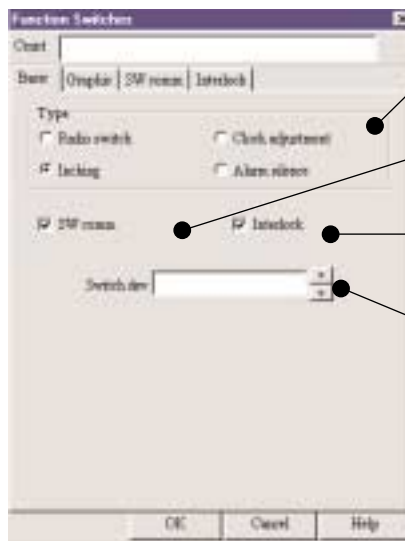

- [Type] This item is for selecting the type of function switch smart object.
- [SW comm] Select this item when using switch communications functions.
- [Interlock] Select this item when using the interlock function.
- [Switch device] This item is for entering the start bit device to be manipulated when a switch is touched.

- Switch device
Enter the start bit device of the inching switch.
Smart objects use continuous bit devices for the number of selected switches from the switch device.

● Graphic

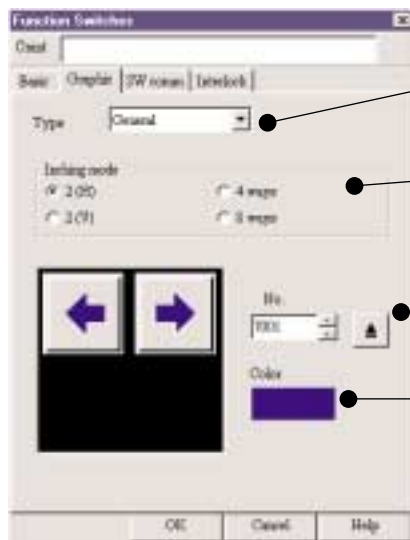

- [Type] This item is for selecting the graphic type.
- [Inching mode] This item is for selecting the inching switch mode.
- [No.] This item is for selecting the switch graphic.
- [Color] This item is for selecting the display color of the switch graphic.

● **Switch Communications**

Set the operation of switch communications functions.

● **Interlock**

Set the entry enabled conditions for the switch.

■ **Example [Inching switch]**

Switch device = M000

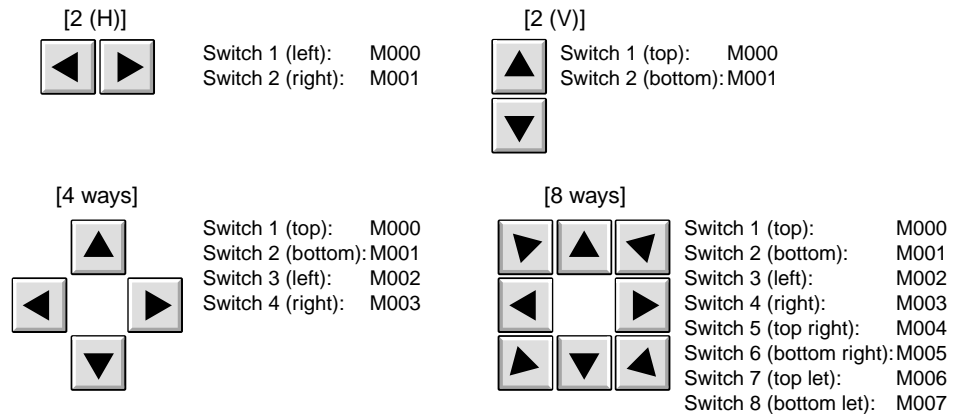

■ **Smart Object Parameters**

Tab name	Parameter name	Selection/setting item	Remarks
Basic	Switch device	Enter the communications channel, device address and bit device.	
	SW comm	Select when switch communications is used.	
	Interlock	Select when using interlocked operation.	
Graphic	Type	Select general.	
	Inching mode	Select the inching switch shape.	
	No.	Select the inching graphic.	
	Color	Select the graphic display color.	
Switch communications	Code 1	Enter the switch code of switch 1.	-32768 to +32767
	Code 2	Enter the switch code of switch 2.	-32768 to +32767
	Code 3	Enter the switch code of switch 3.	When inching mode: 4/8 ways mode is selected
	Code 4	Enter the switch code of switch 4.	
	Code 5	Enter the switch code of switch 5.	When inching mode: 8 ways mode is selected
	Code 6	Enter the switch code of switch 6.	
	Code 7	Enter the switch code of switch 7.	
	Code 8	Enter the switch code of switch 8.	
		Switch communications function	Select the switch communications function.
Interlock	Bit state	Interlock action according to ON/OFF state of bit device	
	Range	Interlock action according to bit device range	

■ Supplementary Explanation

- Multiple switches cannot be touched simultaneously.
- Lamp display functions are not available.
- For details on smart object settings, see “2-2 Main Configuration Items for Smart Objects” (page 2-5).

! Handling Precautions

- Enter the bit device on the PLC for the Switch device. Do not enter word devices such as registers.
- “User” cannot be selected at Type.
- To perform inching operation that requires one-shout output, create a program for executing the desired processing on the PLC.
- The response speed varies depending on the number and types of smart objects used.

Smart object name	Clock Adjustment					
Type	Function switches					
					Scaling	
Enlarge	Reduce	Reshape	Scaling factor	Text size	Paste coordinates	
○	○	○	Any	Fixed	Any	

■ Function

- This smart object calls up clock adjustment panels, and closes the startup source panel and closes other active panels.
- On the clock correction panel, the date (year, month, day) and time (hours, minutes, seconds) of the EST's internal clock can be adjusted.
- When clock adjustments have been completed the clock adjustment panel closes, and the state before the clock adjustment panel was called is returned to.
- The date/time data set by clock adjustment can be written to the PLC using the PLC write function.

■ Configuration

● Basic

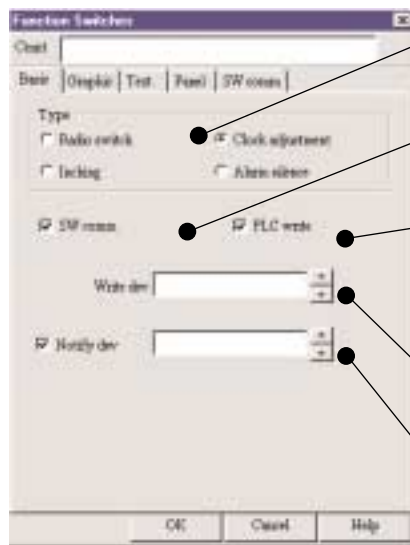

- [Type]
This item is for selecting the type of function switch smart object.
- [SW comm]
Select this item when using switch communications functions.
- [PLC write]
Mark this checkbox to write date/time data that has been changed on the clock setting panel to the PLC.
- Two settings [Write device] and [Notify device] are displayed.
- [Write device]
This item is for entering the start word device on the PLC to which the date/time data is be written.
- [Notify device]
This item is for entering the bit device on the PLC to be notified of completion of writing of the date/time data.

• Write device

Enter the PLC address to which the date/time data is to be written when the with PLC write function is used.
The date/time data is in a 7-word data structure.

Year	(19) 50 to 99 (20) 00 to 35: BCD
Month	01 to 12 : BCD
Day	01 to 31 : BCD
Day of week	0: Sunday, 1:Monday, 2:Tuesday, 3:Tursday, 5:Friday, 6:Saturday
Hour	00 to 23: BCD
Minute	00 to 59: BCD
Second	00 to 59: BCD

• Notify device

When the date/time data is written to the PLC, the bit device entered at Notify device is set, and the PLC is notified that writing of the date/time data has been executed.

● **Graphic**

Set the switch graphic to be displayed on the smart object and the display color of the graphic.

● **Text**

Set the string to be displayed on the smart object and the display text color.

● **Panel**

Set the clock adjustment panel to be used and its call coordinates.

● **Switch Communications**

Set the operation of switch communications functions.

■ **Example [PLC write]**

Write device = D000, notify device = M000

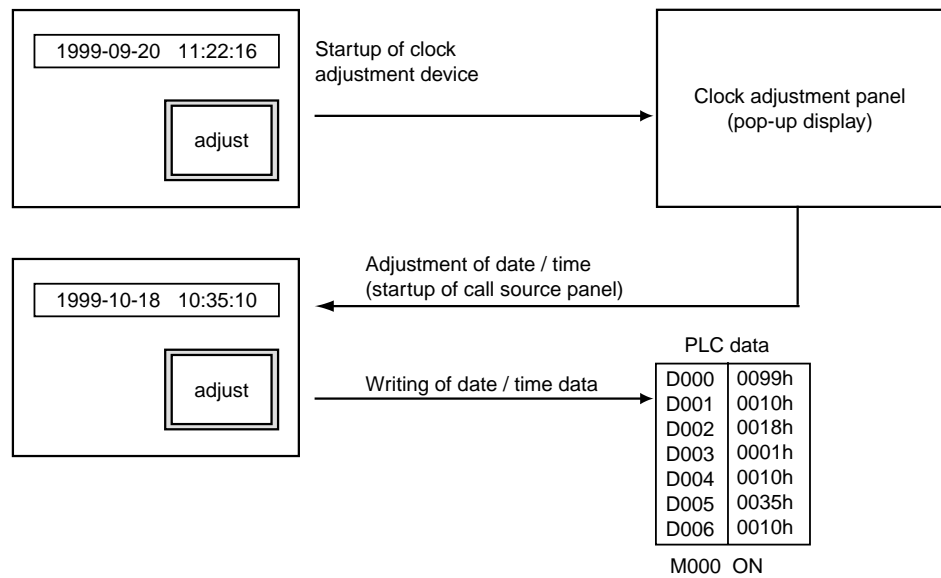

■ Smart Object Parameters

Tab name	Parameter name	Selection/setting item	Remarks
Basic	PLC write	Select when writing the clock setting to the PLC.	
	Write device	Enter the communications channel, device address and bit device.	When function with PLC write is selected
	Notify device	Enter the communications channel, device address and bit device.	When function with PLC write is selected
	SW comm	Select when using switch communications.	
Graphic	Type	Select general.	
	No.	Select the display graphic.	
	Color	Select the display color of the graphic.	
Text	Font size	Select the font size from 8 and 16 dots.	
	V alignment	Select vertical alignment from top/center/bottom.	
	H alignment	Select horizontal alignment from left/center/right.	
	Horizontal scale	Enter the horizontal scale of the string.	1 to 8
	Vertical scale	Enter the vertical scale of the string.	1 to 8
	String	Enter the display text.	
	Text color	Select the display text color.	
Panel	Panel	Enter the clock adjustment panel No. to call up.	1200 to 1202
	Coordinates	Enter the call coordinates of the clock adjustment panel.	
Switch communications	Switch code	Enter the switch code.	-32768 to +32767
	Switch communications function	Select the switch communications function.	

■ Supplementary Explanation

- Timing of writing of date/time data to the PLC is as follows:
The current date/time data is written to the PLC if the clock data has been corrected when the call source panel is returned to from the clock correction panel.
- The EST sets the notification device after the date/time data is written. The EST does not reset the device. Reset the device on the PLC after confirming the ON state of the bit.
- For details on the clock correction panel, see “5-4 Clock Correction” (page 5-10).
- For details on smart object settings, see “2-2 Main Configuration Items for Smart Objects” (page 2-5).

! Handling Precautions

- Be sure to enter a multiple of 16 when entering the bit device on the PLC to write devices.
- Enter the bit device on the PLC for the Notify device. Do not enter word devices such as registers.
- “User” cannot be selected at Graphic type.
- The clock correction panel cannot be called when an opened pop-up panel is active.

Smart object name	Alarm silence					
Type	Function switches					
	Scaling				Paste coordinates	
	Enlarge	Reduce	Reshape	Scaling factor		Text size
	○	○	○	Any	Fixed	Any

■ **Function**

- This smart object turns the EST buzzer output OFF when the switch is touched.

■ **Configuration**

● **Basic**



[Type]
This item is for selecting the type of function switch smart object.

[SW comm]
Select this item when using switch communications functions.

● **Graphic**

Set the switch graphic to be displayed on the smart object and the display color of the graphic.

● **Text**

Set the string to be displayed on the smart object and the display text color.

● **Switch Communications**

Set the operation of switch communications functions.

■ **Smart Object Parameters**

Tab name	Parameter name	Selection/setting item	Remarks
Basic	SW comm	Select when using switch communications.	
Graphic	Type	Select general.	
	No.	Select the display graphic.	
	Color	Select the display color of the graphic.	
Text	Font size	Select the font size from 8 and 16 dots.	
	V alignment	Select vertical alignment from top/center/bottom.	
	H alignment	Select horizontal alignment from left/center/right.	
	Horizontal scale	Enter the horizontal scale of the string.	1 to 8
	Vertical scale	Enter the vertical scale of the string.	1 to 8
	String	Enter the display text.	
	Text color	Enter the display text color.	
Switch communications	Switch code	Enter the switch code.	-32768 to +32767
	Switch communications function	Select the switch communications function.	

■ Supplementary Explanation

- This smart object is used to turn OFF the buzzer sound output that is initiated by an alarm buzzer smart object used in alarm monitoring.
- For details on smart object settings, see “2-2 Main Configuration Items for Smart Objects” (page 2-5).

! Handling Precautions

- “User” cannot be selected at Graphic type.

3 - 3 Word Type Switches

Smart object name	Word data write						
Type	Word type switches						
					Scaling		Paste coordinates
Enlarge		Reduce		Reshape	Scaling factor	Text size	
○		○		○	Any	Fixed	Any

■ Function

- This smart object writes up to 64 words of data to the write destination device starting from the device specified as the write source device by touching a switch.
- These smart objects can also be used between devices having different EST connection channels and communications address, for example, when IMEC data is written to the PLC or PLC data is written to the IMEC.
- Switch graphics are changed according to the ON/OFF state of the lamp device on the PLC.
- The display of the graphic and text can be cleared by setting the Hide device to ON.

■ Configuration

● Basic

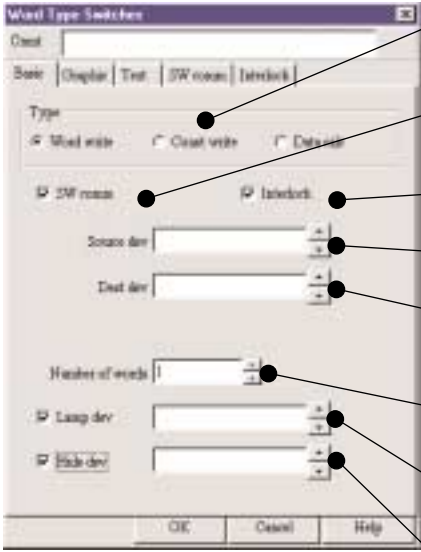

The screenshot shows the 'Word Type Switches' dialog box with the following settings and callouts:

- [Type]**: This item is for selecting the type of function switch smart object. (Callout points to the 'Type' dropdown menu)
- [SW comm]**: Select this item when using switch communications functions. (Callout points to the 'SW comm' radio button)
- [Interlock]**: Select this item when using the interlock function. (Callout points to the 'Interlock' radio button)
- [Source device]**: This item is for entering the write source device. (Callout points to the 'Source dev' text box)
- [Destination device]**: This item is for entering the write destination device of the write data. (Callout points to the 'Dest dev' text box)
- [Number of words]**: This item is for entering the number of data words to be written. (Callout points to the 'Number of words' spinner box)
- [Lamp device]**: This item is for entering the bit device to be monitored for switching graphic and text display. (Callout points to the 'Lamp dev' text box)
- [Hide device]**: This item is for entering the bit device for clearing the graphic and text display. (Callout points to the 'Hide dev' text box)

● Graphic

Set the switch graphic to be displayed on the smart object and the display color of the graphic.

When a lamp device is used, the graphic setting becomes OFF Graphic and ON Graphic.

● Text

Set the string to be displayed on the smart object and the display text color.

When a lamp device is used, the string setting becomes OFF string and ON string.

● Switch Communications

Set the operation of switch communications functions.

● Interlock

Set the entry enabled conditions for the switch.

■ Example

Write source device = D000, write destination device = D100, number of words = 3

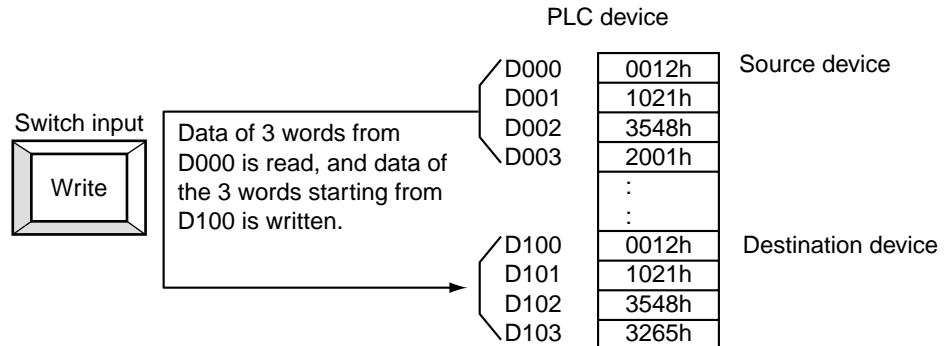

■ Smart Object Parameters

Tab name	Parameter name	Selection/setting item	Remarks
Basic	Source device	Enter the communications channel, the device address, and the word device.	
	Destination device	Enter the communications channel, the device address, and the word device.	
	Number of words	Enter the number of write words.	1 to 64
	Lamp device	Enter the communications channel, the device address, and the bit device.	
	Hide device	Enter the communications channel, the device address, and the bit device.	
	SW comm	Select when using switch communications.	
	Interlock	Select when using interlocked operation.	
Graphic	Type	Select the graphic type from general/user.	
	OFF Graphic	Select the graphic displayed at OFF.	
	Color when OFF	Select the display color of the OFF Graphic.	
	Blink when OFF	Select to cause blinking at OFF.	When lamp devices are used
	ON Graphic	Select the display graphic when the lamp is ON.	When lamp devices are used
	Color when ON	Select the display color of the graphic when the lamp is ON.	When lamp devices are used
Text	Blink when ON	Select to cause blinking when the lamp is ON.	When lamp devices are used
	Font size	Select the font size from 8 and 16 dots.	
	V alignment	Select vertical alignment from top/center/bottom.	
	H alignment	Select horizontal alignment from left/center/right.	
	Horizontal scale	Enter the horizontal scale of the string.	1 to 8
	Vertical scale	Enter the vertical scale of the string.	1 to 8
	OFF string	Enter the display text at OFF.	
	OFF color	Enter the display text color when OFF.	
	Blink when OFF	Select to cause blinking at OFF.	When lamp devices are used
	ON string	Select the display text when the lamp is ON.	When lamp devices are used
ON color	Select the display text color when the lamp is ON.	When lamp devices are used	
Blink when ON	Select to cause blinking when the lamp is ON.	When lamp devices are used	
Switch communications	Switch code	Enter the switch code.	-32768 to +32767
	Switch communications function	Select the switch communications function.	
Interlock	Bit state	Interlock action according to ON/OFF state of bit device	
	Range	Interlock action according to bit device range	

■ Supplementary Explanation

- Select OFF Graphic for the graphic selection when a lamp device is used. OFF Graphic is paired with ON Graphic and is automatically selected. Note, however, that OFF Graphic/ON Graphic can be freely selected from registered graphics when “User” has been selected at Graphic type.
- The data area of the write destination functions properly even if its addresses are the same as those of the data area at the data area of the write source.

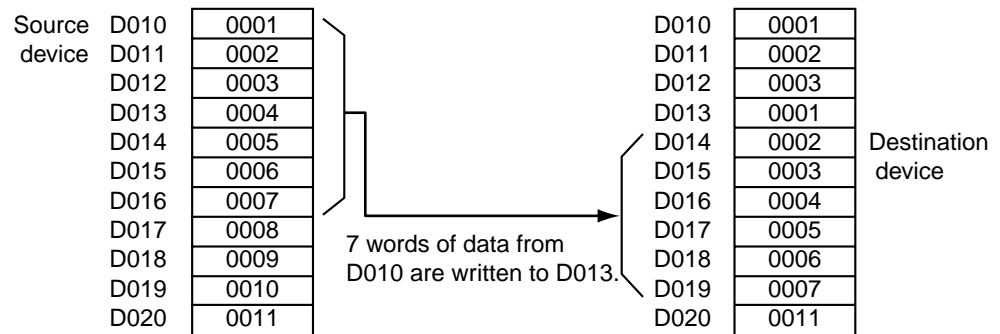

- For details on smart object settings, see “2-2 Main Configuration Items for Smart Objects” (page 2-5).

! Handling Precautions

- Enter the bit device on the PLC for Lamp/Hide device. Do not enter word devices such as registers.
- Enter the word device on the PLC as the write source/write destination device. Do not enter bit devices such as relays.
- When a registered graphic is used for the switch graphic, the OFF graphic and ON graphic to be displayed must be created at the same size.
- When a registered graphic is used for the switch graphic, the smart object size becomes the size of the graphic, and the smart object cannot be scaled.

Smart object name	Constant write					
Type	Word type switches					
	Scaling					Paste coordinates
	Enlarge	Reduce	Reshape	Scaling factor	Text size	
	<input type="radio"/>	<input type="radio"/>	<input type="radio"/>	Any	Fixed	Any

■ Function

- This smart object writes up to 64 words of constants entered to write data starting from the write device by touching a switch.
- Switch graphics are changed according to the ON/OFF state of the lamp device on the PLC.
- The display of the graphic and text can be cleared by setting the Hide device to ON.

■ Configuration

● Basic

The screenshot shows the 'Word Type Switches' dialog box with the following settings and callouts:

- [Type]**: This item is for selecting the type of function switch smart object. (Callout points to the 'Type' dropdown menu)
- [SW comm]**: Select this item when using switch communications functions. (Callout points to the 'SW comm' radio button)
- [Interlock]**: Select this item when using the interlock function. (Callout points to the 'Interlock' radio button)
- [Format]**: This item is for selecting the data format of constants to be entered to the write data. (Callout points to the 'Format' dropdown menu)
- [Write device]**: This item is for entering the write destination device for the data. (Callout points to the 'Write dev' text box)
- [Write data]**: This item is for entering the constants to be written to the PLC. (Callout points to the 'Write data' text box)
- [Number of words]**: This item is for entering the number of data (constant) words to be written. (Callout points to the 'Number of words' text box)
- [Lamp device]**: This item is for entering the bit device to be monitored for switching graphic or text display. (Callout points to the 'Lamp dev' text box)
- [Hide device]**: This item is for entering the bit device for clearing the graphic or text display. (Callout points to the 'Hide dev' text box)

● Graphic

Set the switch graphic to be displayed on the smart object and the display color of the graphic.

When a lamp device is used, the graphic setting becomes OFF Graphic and ON Graphic.

● Text

Set the string to be displayed on the smart object and the display text color.

When a lamp device is used, the string setting becomes OFF string and ON string.

● Switch Communications

Set the operation of switch communications functions.

● Interlock

Set the entry enabled conditions for the switch.

■ Example

Write device = D000, write data = 0, number of words = 5

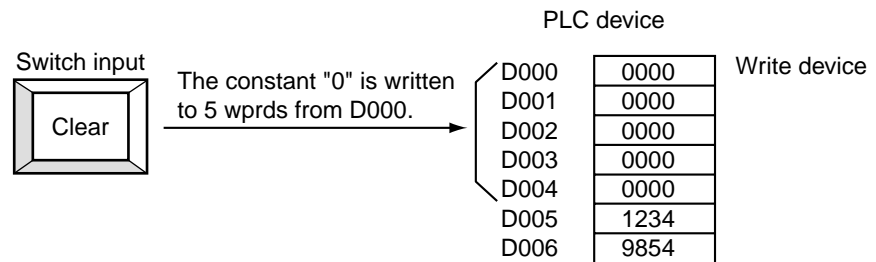

■ Smart Object Parameters

Tab name	Parameter name	Selection/setting item	Remarks
Basic	Write device	Enter the communications channel, the device address, and the word device.	
	Format	Select the write data format from unsigned binary/signed binary/Hex/BCD.	
	Write data	Enter the constant of 1 word.	Unsigned binary: 0 to 65535 Signed binary: -32768 to +32767 Hex: 0000 to FFFF BCD: 0000 to 9999
	Number of words	Enter the number of write words.	1 to 64
	Lamp device	Enter the communications channel, the device address, and the bit device.	
	Hide device	Enter the communications channel, the device address, and the bit device.	
	SW comm	Select when using switch communications.	
	Interlock	Select when using interlocked operation.	
Graphic	Type	Select the graphic type from general/user.	
	OFF Graphic	Select the graphic displayed at OFF.	
	Color when OFF	Select the display color of the OFF Graphic.	
	Blink when OFF	Select to cause blinking at OFF.	When lamp devices are used
	ON Graphic	Select the display graphic when the lamp is ON.	When lamp devices are used
	Color when ON	Select the display color of the graphic when the lamp is ON.	When lamp devices are used
Text	Blink when ON	Select to cause blinking when the lamp is ON.	When lamp devices are used
	Font size	Select the font size from 8 and 16 dots.	
	V alignment	Select vertical alignment from top/center/bottom.	
	H alignment	Select horizontal alignment from left/center/right.	
	Horizontal scale	Enter the horizontal scale of the string.	1 to 8
	Vertical scale	Enter the vertical scale of the string.	1 to 8
	OFF string	Enter the display text at OFF.	
	OFF color	Enter the display text color when OFF.	
	Blink when OFF	Select to cause blinking at OFF.	When lamp devices are used
	ON string	Select the display text when the lamp is ON.	When lamp devices are used
ON color	Select the display text color when the lamp is ON.	When lamp devices are used	
Switch communications	Blink when ON	Select to cause blinking when the lamp is ON.	When lamp devices are used
	Switch code	Enter the switch code.	-32768 to +32767
Interlock	Switch communications function	Select the switch communications function.	
	Bit state	Interlock action according to ON/OFF state of bit device	
	Range	Interlock action according to bit device range	

■ Supplementary Explanation

- Select OFF Graphic for the graphic selection when a lamp device is used. OFF Graphic is paired with ON Graphic and is automatically selected. Note, however, that OFF Graphic/ON Graphic can be freely selected from registered graphics when “User” has been selected at Graphic type.
- For details on smart object settings, see “2-2 Main Configuration Items for Smart Objects” (page 2-5).

! Handling Precautions

- Enter the bit device on the PLC for Lamp/Hide device. Do not enter word devices such as registers.
- Enter the word device on the PLC as the write device. Do not enter bit devices such as relays.
- When a registered graphic is used for the switch graphic, the OFF graphic and ON graphic to be displayed must be created at the same size.
- When a registered graphic is used for the switch graphic, the smart object size becomes the size of the graphic, and the smart object cannot be scaled.

Smart object name	Data calculation					
Type	Word type switches					
	Scaling					Paste coordinates
	Enlarge	Reduce	Reshape	Scaling factor	Text size	Any
	<input type="radio"/>	<input type="radio"/>	<input type="radio"/>	Any	Fixed	Any

■ **Function**

- This smart object adds/subtracts calculation data before writing to the numeric device on the PLC when a switch is touched.
- When the calculation result exceeds the upper limit value/lower limit value settings, the setting values of the upper limit value/lower limit value are written to the numeric device.
- Combinations of data add switches and data subtract switches can be used as a data UP/DOWN setter.
- The display of the graphic and text can be cleared by setting the Hide device to ON.

■ **Configuration**

● **Basic**

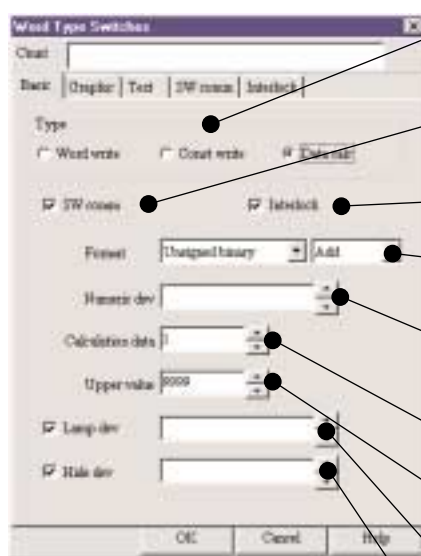

- [Type]
This item is for selecting the type of function switch smart object.
- [SW comm]
Select this item when using switch communications functions.
- [Interlock]
Select this item when using the interlock function.
- [Format]
This item is for selecting the calculation data format and calculation type.
- [Numeric device]
This item is for entering the word device to be targeted for calculation.
- [Calculation data]
This item is for entering calculation data (constants).
- [Upper/lower value]
This item is for entering the upper limit value/lower limit value of the data.
- [Lamp device]
This item is for entering the bit device to be monitored for switching graphic or text display.
- [Hide device]
This item is for entering the bit device for clearing the graphic or text display.

● **Graphic**

Set the switch graphic to be displayed on the smart object and the display color of the graphic.

When a lamp device is used, the graphic setting becomes OFF Graphic and ON Graphic.

● **Text**

Set the string to be displayed on the smart object and the display text color.

When a lamp device is used, the string setting becomes OFF string and ON string.

● **Switch Communications**

Set the operation of switch communications functions.

● **Interlock**

Set the entry enabled conditions for the switch.

■ **Example**

Numeric device = D010, calculation data = 5, data format = unsigned binary/addition

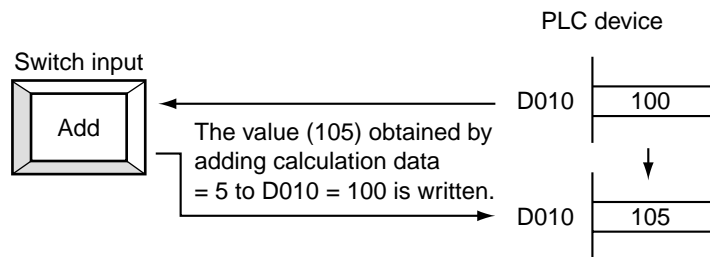

■ **Smart Object Parameters**

Tab name	Parameter name	Selection/setting item	Remarks
Basic	Numeric device	Enter the communications channel, the device address, and the word device.	
	Format	Select the write data format from unsigned binary/signed binary/Hex/BCD. Select the calculation type from addition/subtraction.	
	Calculation data	Enter the calculation data.	Unsigned binary: 0 to 65535 Signed binary: -32768 to +32767 Hex: 0000 to FFFF BCD: 0000 to 9999
	Upper value	Enter the upper limit value of the addition.	When addition is selected
	Lower value	Enter the lower limit value of the subtraction.	When subtraction is selected
	Lamp device	Enter the communications channel, the device address, and the bit device.	
	Hide device	Enter the communications channel, the device address, and the bit device.	
	SW comm	Select when using switch communications.	
Graphic	Interlock	Select when using interlocked operation.	
	Type	Select the graphic type from general/user.	
	OFF Graphic	Select the graphic displayed at OFF.	
	Color when OFF	Select the display color of the OFF Graphic.	
	Blink when OFF	Select to cause blinking at OFF.	When lamp devices are used
	ON Graphic	Select the display graphic when the lamp is ON.	When lamp devices are used
	Color when ON	Select the display color of the graphic when the lamp is ON.	When lamp devices are used
Text	Blink when ON	Select to cause blinking when the lamp is ON.	When lamp devices are used
	Font size	Select the font size from 8 and 16 dots.	
	V alignment	Select vertical alignment from top/center/bottom.	
	H alignment	Select horizontal alignment from left/center/right.	
	Horizontal scale	Enter the horizontal scale of the string.	1 to 8
	Vertical scale	Enter the vertical scale of the string.	1 to 8
	OFF string	Enter the display text at OFF.	
	OFF color	Enter the display text color when OFF.	
	Blink when OFF	Select to cause blinking at OFF.	When lamp devices are used
	ON string	Select the display text when the lamp is ON.	When lamp devices are used
Switch communications	ON color	Select the display text color when the lamp is ON.	When lamp devices are used
	Blink when ON	Select to cause blinking when the lamp is ON.	When lamp devices are used
Interlock	Switch code	Enter the switch code.	-32768 to +32767
	Switch communications function	Select the switch communications function.	
	Bit state	Interlock action according to ON/OFF state of bit device	
	Range	Interlock action according to bit device range	

■ Supplementary Explanation

- Select OFF Graphic for the graphic selection when a lamp device is used. OFF Graphic is paired with ON Graphic and is automatically selected. Note, however, that OFF Graphic/ON Graphic can be freely selected from registered graphics when “User” has been selected at Graphic type.
- When “Add” has been set at Format, the upper/lower value setting becomes the upper value setting, and the lower value setting is not available. When “Sub” has been set, the upper/lower value setting becomes the lower value setting, and the lower value setting is not available.
- For details on smart object settings, see “2-2 Main Configuration Items for Smart Objects” (page 2-5).

! Handling Precautions

- Enter the bit device on the PLC for Lamp/Hide device. Do not enter word devices such as registers.
- Be sure to enter a multiple of 16 when entering the bit device on the numeric devices.
- When the data of the numeric device is not BCD data in calculations on BCD format data, the upper/lower limit setting values are written to the numeric device.
- When a registered graphic is used for the switch graphic, the OFF graphic and ON graphic to be displayed must be created at the same size.
- When a registered graphic is used for the switch graphic, the smart object size becomes the size of the graphic, and the smart object cannot be scaled.

3 - 4 Panel Change Switches

Smart object name	Panel change switch, panel selector						
Type	Panel change switches						
					Scaling		Paste coordinates
		Enlarge	Reduce	Reshape	Scaling factor	Text size	
		<input type="radio"/>	<input type="radio"/>	<input type="radio"/>	Any	Fixed	Any

■ Function

- This smart object opens the specified panel, and closes the startup source panel and closes other active panels when a switch is touched.
- The call coordinates of the panel to be started up can be specified.

■ Configuration

● Basic

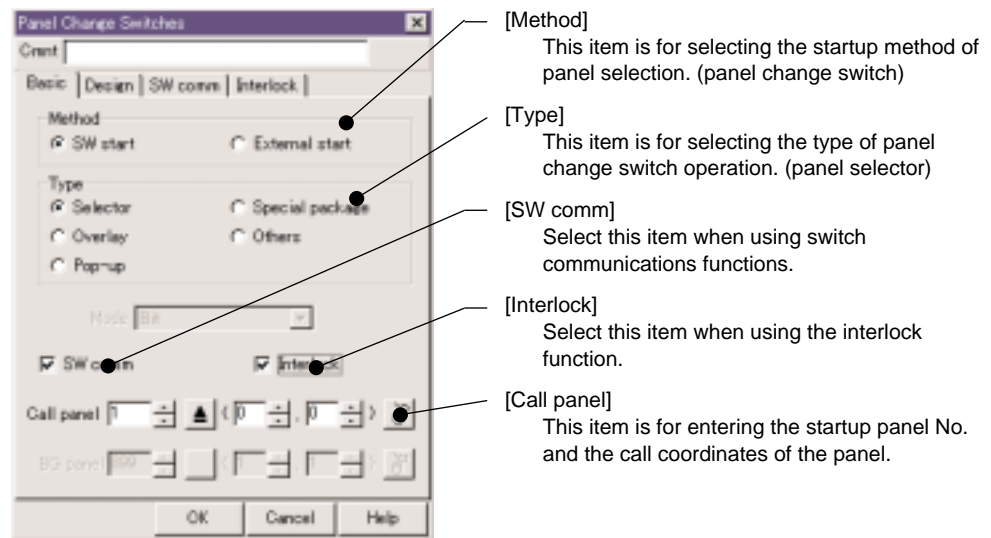

● Design

Set the switch graphic and the display string.

● Switch Communications

Set the operation of switch communications functions.

● Interlock

Set the entry enabled conditions for the switch.

■ Example

Call panel = 10, call coordinates = (20, 10)

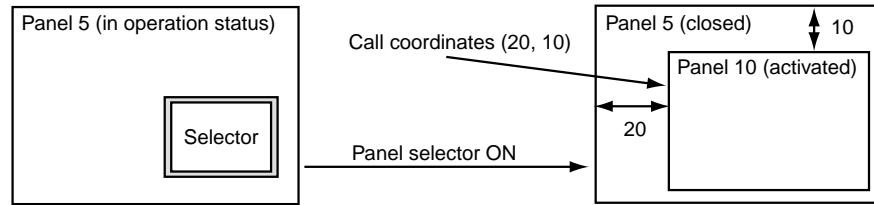

■ Smart Object Parameters

Tab name	Parameter name	Selection/setting item	Remarks
Basic	Call panel	Enter the panel No. to be started up.	1 to 899
	Coordinates	Enter the call coordinates of the panel to be started up.	
	SW comm	Select when using switch communications.	
	Interlock	Select when using interlocked operation.	
Design	Type	Select the graphic type from general/user.	
	No.	Select the display graphic.	
	Color	Select the display color of the graphic.	
	Font size	Select the font size from 8 and 16 dots.	
	V alignment	Select vertical alignment from top/center/bottom.	
	H alignment	Select horizontal alignment from left/center/right.	
	Horizontal scale	Enter the horizontal scale of the string.	1 to 8
	Vertical scale	Enter the vertical scale of the string.	1 to 8
	Display string	Enter the display color.	
	Text color	Enter the display text color.	
Switch communications	Switch code	Enter the switch code.	-32768 to +32767
	Switch communications function	Select the switch communications function.	
Interlock	Bit state	Interlock action according to ON/OFF state of bit device	
	Range	Interlock action according to bit device range	

■ Supplementary Explanation

- Screens other than the newly started up panel stay displayed, however their operations are suspended.
- There is no change to operation of the background panel.
- For details on smart object settings, see “2-2 Main Configuration Items for Smart Objects” (page 2-5).

! Handling Precautions

- When an unregistered panel No. is entered, the panel is not opened even if the switch is touched.
- When an opened pop-up panel is active, other panels cannot be started by this smart object.
- When “User” is selected at Graphic type and registered graphics are used for the switch graphic, the smart object size becomes the size of the graphic, and the smart object cannot be scaled.

Smart object name	Panel change switch, panel overlay						
Type	Panel change switches						
					Scaling		
		Enlarge	Reduce	Reshape	Scaling factor	Text size	Paste coordinates
		<input type="radio"/>	<input type="radio"/>	<input type="radio"/>	Any	Fixed	Any

■ **Function**

- This smart object starts up the specified panel. The startup source panel and other active panels remain active.
- The call coordinates of the panel to be started up can be specified.

■ **Configuration**

● **Basic**

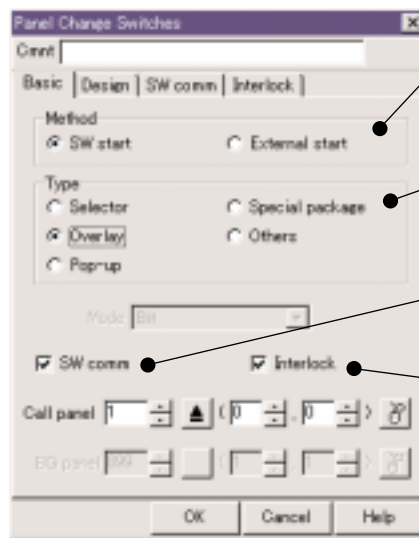

[Method]
This item is for selecting the startup method of panel selection. (panel change switch)

[Type]
This item is for selecting the type of panel change switch operation. (cascade)

[SW comm]
Select this item when using switch communications functions.

[Interlock]
Select this item when using the interlock function.

[Call panel]
This item is for entering the startup panel No. and the call coordinates of the panel.

● **Design**

Set the switch graphic and the display string.

● **Switch Communications**

Set the operation of switch communications functions.

● **Interlock**

Set the entry enabled conditions for the switch.

■ Example

Call panel = 10, call coordinates = (20, 10)

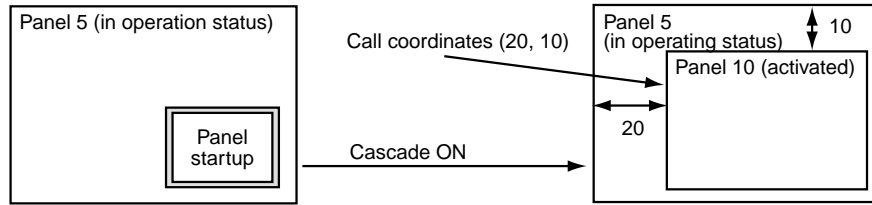

■ Smart Object Parameters

Tab name	Parameter name	Selection/setting item	Remarks
Basic	Call panel	Enter the panel No. to be started up.	1 to 899
	Coordinates	Enter the call coordinates of the panel to be started up.	
	SW comm	Select when using switch communications.	
	Interlock	Select when using interlocked operation.	
Design	Type	Select the graphic type from general/user.	
	No.	Select the display graphic.	
	Color	Select the display color of the graphic.	
	Font size	Select the font size from 8 and 16 dots.	
	V alignment	Select vertical alignment from top/center/bottom.	
	H alignment	Select horizontal alignment from left/center/right.	
	Horizontal scale	Enter the horizontal scale of the string.	1 to 8
	Vertical scale	Enter the vertical scale of the string.	1 to 8
	Display string	Enter the display color.	
	Text color	Enter the display text color.	
Switch communications	Switch code	Enter the switch code.	-32768 to +32767
	Switch communications function	Select the switch communications function.	
Interlock	Bit state	Interlock action according to ON/OFF state of bit device	
	Range	Interlock action according to bit device range	

■ Supplementary Explanation

- The following smart objects are used for closing opened panels.

Smart object type	Smart object name	Function
Panel change switches	Switch start, panel selector	Starts up the specified panels, and stops all other currently active panels.
	External start, panel selector	Executes the panel selector by the PLC device.
	Switch start, panel close	Stops the own panel.
	External start, panel close	Stops the specified panel by the PLC device.

- There is no change to operation of the background panel.
- For details on smart object settings, see "2-2 Main Configuration Items for Smart Objects" (page 2-5).

! Handling Precautions

- When an unregistered panel No. is entered, the panel is not opened even if the switch is touched.
- Up to eight panels including the background panel can be started up simultaneously.
- When an opened pop-up panel is active, other panels cannot be started by this smart object.
- When "User" is selected at Graphic type and registered graphics are used for the switch graphic, the smart object size becomes the size of the graphic, and the smart object cannot be scaled.

Smart object name	Panel change switch, open pop-up						
Type	Panel change switches						
					Scaling		
		Enlarge	Reduce	Reshape	Scaling factor	Text size	Paste coordinates
		<input type="radio"/>	<input type="radio"/>	<input type="radio"/>	Any	Fixed	Any

■ **Function**

● **Startup**

- This smart object causes the specified panel to pop up and start, and closes the startup source panel and closes other active panels.
- The call coordinates of the panel to be started up can be specified.

● **Return**

- This smart object clears the active pop-up panel, and returns to the state before the panel was activated.
- This smart object is pasted to the panel to be started up.

■ **Configuration**

● **Basic**

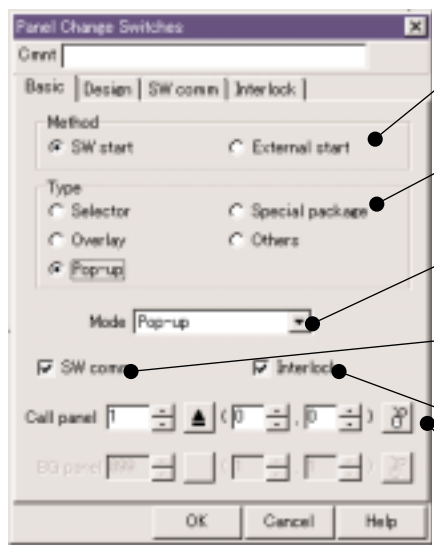

[Method]
This item is for selecting the startup method of panel selection. (panel change switch)

[Type]
This item is for selecting the type of panel change switch operation. (pop-up)

[Mode]
This item is for selecting the operation mode of the smart object from Pop-up/Return.

[SW comm]
Select this item when using switch communications functions.

[Interlock]
Select this item when using the interlock function.

[Call panel]
This item is for entering the startup panel No. and the call coordinates of the panel.

● **Design**

Set the switch graphic and the display string.

● **Switch Communications**

Set the operation of switch communications functions.

● **Interlock**

Set the entry enabled conditions for the switch.

■ Example

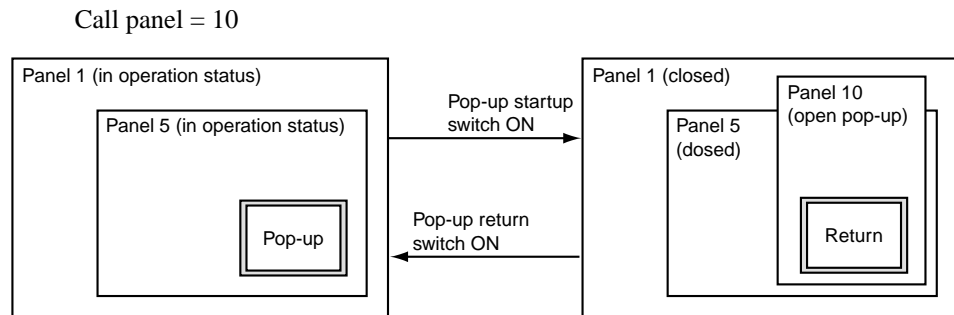

■ Smart Object Parameters

Tab name	Parameter name	Selection/setting item	Remarks
Basic	Mode	Select the pop-up action from pop-up/return.	
	Call panel	Enter the panel No. to be started up.	When open pop-up is selected
	Coordinates	Enter the call coordinates of the panel to be started up.	1 to 899
	SW comm	Select when using switch communications.	
	Interlock	Select when using interlocked operation.	
Design	Type	Select the graphic type from general/user.	
	No.	Select the display graphic.	
	Color	Select the display color of the graphic.	
	Font size	Select the font size from 8 and 16 dots.	
	V alignment	Select vertical alignment from top/center/bottom.	
	H alignment	Select horizontal alignment from left/center/right.	
	Horizontal scale	Enter the horizontal scale of the string.	1 to 8
	Vertical scale	Enter the vertical scale of the string.	1 to 8
Switch communications	Display string	Enter the display color.	
	Text color	Enter the display text color.	
Switch communications	Switch code	Enter the switch code.	-32768 to +32767
	Switch communications function	Select the switch communications function.	
Interlock	Bit state	Interlock action according to ON/OFF state of bit device	
	Range	Interlock action according to bit device range	

■ Supplementary Explanation

- Pop-up return is used only to close an active pop-up panel.
- The call panel setting is not available when pop-up return is selected.
- There is no change to operation of the background panel.
- For details on smart object settings, see “2-2 Main Configuration Items for Smart Objects” (page 2-5).

! Handling Precautions

- If an unregistered panel No. is entered to the call panel when pop-up startup is selected, nothing happens by touching this switch.
- This smart object does not function when an open pop-up panel is active.
- Set pop-up return smart objects to the panel to be pop-up started up. Open active pop-up panels cannot be cleared by other smart objects.
- When "User" is selected at Graphic type and registered graphics are used for the switch graphic, the smart object size becomes the size of the graphic, and the smart object cannot be scaled.

Smart object name	Panel change switch, special package selector					
Type	Panel change switches					
	Scaling				Paste coordinates	
	Enlarge	Reduce	Reshape	Scaling factor		Text size
	<input type="radio"/>	<input type="radio"/>	<input type="radio"/>	Any	Fixed	Any

■ **Function**

- This smart object starts up the special package when a switch is touched, and closes the startup source panel and other active panels.

■ **Configuration**

● **Basic**

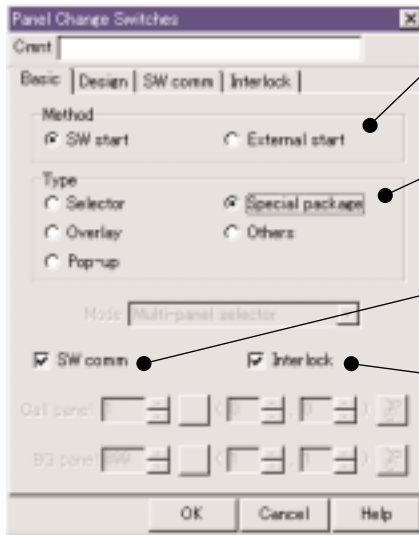

- [Method] This item is for selecting the startup method of panel selection. (panel change switch)
- [Type] This item is for selecting the type of panel change switch operation. (special package)
- [SW comm] Select this item when using switch communications functions.
- [Interlock] Select this item when using the interlock function.

● **Design**

Set the switch graphic and the display string.

● **Switch Communications**

Set the operation of switch communications functions.

● **Interlock**

Set the entry enabled conditions for the switch.

■ Example

When the DMC10 is being downloaded

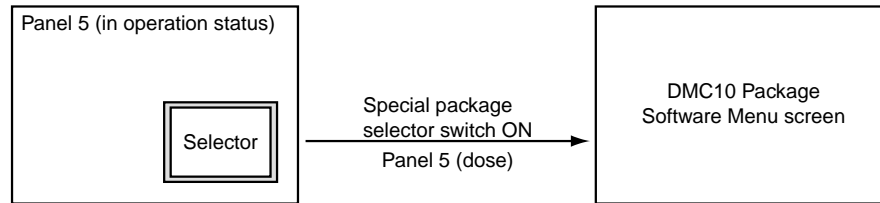

■ Smart Object Parameters

Tab name	Parameter name	Selection/setting item	Remarks
Basic	SW comm	Select when using switch communications.	
	Interlock	Select when using interlocked operation.	
Design	Type	Select the graphic type from general/user.	
	No.	Select the display graphic.	
	Color	Select the display color of the graphic.	
	Font size	Select the font size from 8 and 16 dots.	
	V alignment	Select vertical alignment from top/center/bottom.	
	H alignment	Select horizontal alignment from left/center/right.	
	Horizontal scale	Enter the horizontal scale of the string.	1 to 8
	Vertical scale	Enter the vertical scale of the string.	1 to 8
	Display string	Enter the display color.	
Text color	Enter the display text color.		
Switch communications	Switch code	Enter the switch code.	-32768 to +32767
	Switch communications function	Select the switch communications function.	
Interlock	Bit state	Interlock action according to ON/OFF state of bit device	
	Range	Interlock action according to bit device range	

■ Supplementary Explanation

- “Special packages” are library software packages such as the DMC10 package prepared by Yamatake. They cannot be created nor modified.
For details on special packages, refer to Smart Terminal EST240Z User's Manual Application Preparation Manual No.CP-SP-1088E.”
For details on the DMC10 package, refer to Smart Terminal EST240Z User's Manual DMC10 Package Manual No.CP-SP-1091E.
- There is no change to operation of the background panel.
- For details on smart object settings, see “2-2 Main Configuration Items for Smart Objects” (page 2-5).

! Handling Precautions

- Touching the switch will not select the special package when the special package is not being downloaded to the EST.
- When an opened pop-up panel is active, other panels cannot be started by this smart object.
- When “User” is selected at Graphic type and registered graphics are used for the switch graphic, the smart object size becomes the size of the graphic, and the smart object cannot be scaled.

Smart object name	Panel change switch, multi-panel selector [others]					
Type	Panel change switches					
	Scaling				Paste coordinates	
	Enlarge	Reduce	Reshape	Scaling factor		Text size
	○	○	○	Any	Fixed	Any

■ **Function**

- This smart object starts up a maximum of three panels simultaneously. It also closes the startup source panel and other active panels.
- Each of the call coordinates of the panels to be started up can be specified.

■ **Configuration**

● **Basic**

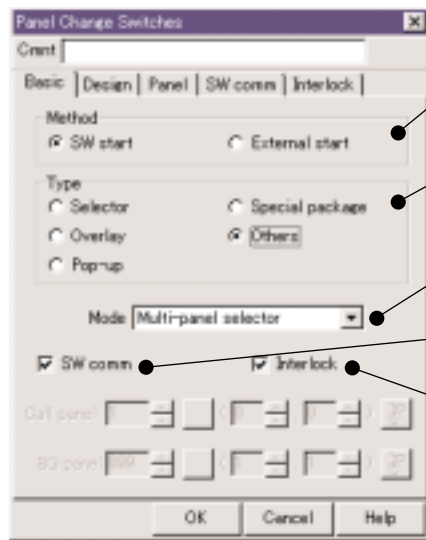

- [Method]
This item is for selecting the startup method of panel selection. (panel change switch)
- [Type]
This item is for selecting the type of panel change switch operation. (others)
- [Mode]
This item is for selecting the operation mode of the smart object. (multi-panel selector)
- [SW comm]
Select this item when using switch communications functions.
- [Interlock]
Select this item when using the interlock function.

● **Panel**

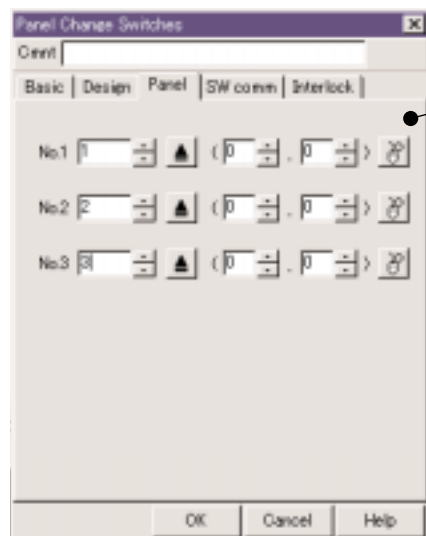

- [Startup panels No.1/2/3]
This item is for selecting up to three panels to be started up.

● **Design**

Set the switch graphic and the display string.

● **Switch Communications**

Set the operation of switch communications functions.

● **Interlock**

Set the entry enabled conditions for the switch.

■ **Example**

Call panel: No.1 = 10, No.2 = 20, No.3 = 30

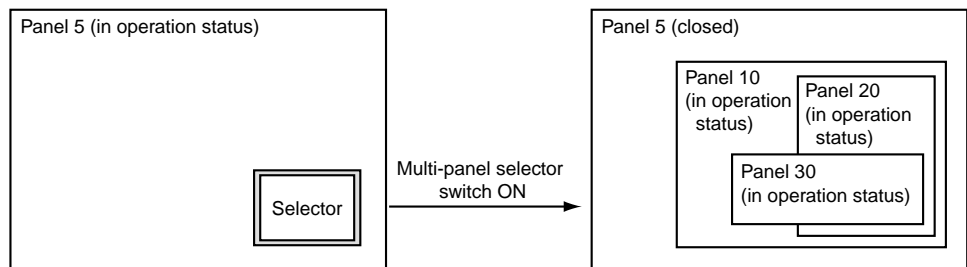

■ **Smart Object Parameters**

Tab name	Parameter name	Selection/setting item	Remarks
Basic	Mode	Select multi-panel selector.	
	SW comm	Select when using switch communications.	
	Interlock	Select when using interlocked operation.	
Design	Graphic Type	Select the graphic type from general/user.	
	Graphic No.	Select the display graphic.	
	Fill color	Select the display color of the graphic.	
	Font size	Select the font size from 8 and 16 dots.	
	V alignment	Select vertical alignment from top/center/bottom.	
	H alignment	Select horizontal alignment from left/center/right.	
	Horizontal scale	Enter the horizontal scale of the string.	1 to 8
	Vertical scale	Enter the vertical scale of the string.	1 to 8
	Display string	Enter the display color.	
Panel	No.1 call panel	Enter the panel No. to be started up.	1 to 899
	No.1 coordinates	Enter the call coordinates of the panel to be started up.	
	No.2 call panel	Enter the panel No. to be started up.	0 to 899
	No.2 coordinates	Enter the call coordinates of the panel to be started up.	
	No.3 call panel	Enter the panel No. to be started up.	0 to 899
Switch communications	No.3 coordinates	Enter the call coordinates of the panel to be started up.	
	Switch code	Enter the switch code.	-32768 to +32767
Interlock	Switch communications function	Select the switch communications function.	
	Bit state	Interlock action according to ON/OFF state of bit device	
	Range	Interlock action according to bit device range	

■ Supplementary Explanation

- Panels other than the newly started up panel stay displayed, however their operations are suspended.
- To start up two panels, specify “0” as the panel No. of No.3.
- Panels are started up in order from the No.1 specified panel. Accordingly, the last started up panel is displayed on top when the panel display areas are overlapping.
- There is no change to operation of the background panel.
- For details on smart object settings, see “2-2 Main Configuration Items for Smart Objects” (page 2-5).

❗ Handling Precautions

- When an opened pop-up panel is active, other panels cannot be started by this smart object.
- If the panels specified by panel No.1, 2 and 3 do not exist, all panel operations other than the background panel are suspended.
- When “User” is selected at Graphic type and registered graphics are used for the switch graphic, the smart object size becomes the size of the graphic, and the smart object cannot be scaled.

Smart object name	Panel change switch, multi-panel overlay [others]					
Type	Panel change switches					
	Scaling					Paste coordinates
	Enlarge	Reduce	Reshape	Scaling factor	Text size	
	<input type="radio"/>	<input type="radio"/>	<input type="radio"/>	Any	Fixed	Any

■ **Function**

- This smart object starts up a maximum of three panels simultaneously. The startup source panel and other active panels remain active.
- Each of the call coordinates of the panels to be started up can be specified.

■ **Configuration**

● **Basic**

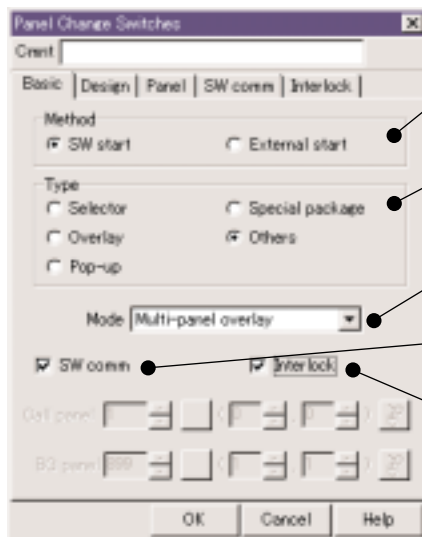

- [Method]
This item is for selecting the startup method of panel selection. (panel change switch)
- [Type]
This item is for selecting the type of panel change switch operation. (others)
- [Mode]
This item is for selecting the operation mode of the smart object. (multi-panel overlay)
- [SW comm]
Select this item when using switch communications functions.
- [Interlock]
Select this item when using the interlock function.

● **Panel**

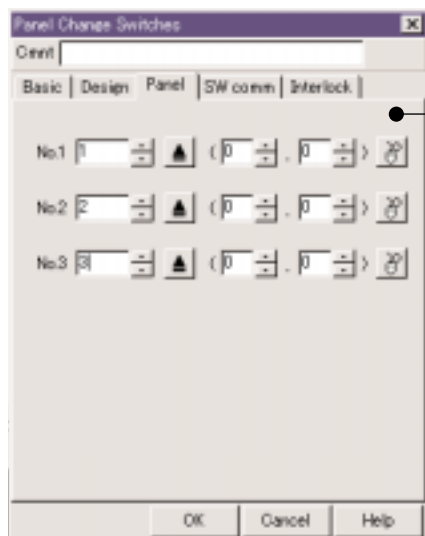

- [Startup panels No.1/2/3]
This item is for selecting up to three panels to be started up.

● **Design**

Set the switch graphic and the display string.

● **Switch Communications**

Set the operation of switch communications functions.

● **Interlock**

Set the entry enabled conditions for the switch.

■ **Example**

Call panel: No.1 = 10, No.2 = 20, No.3 = 30

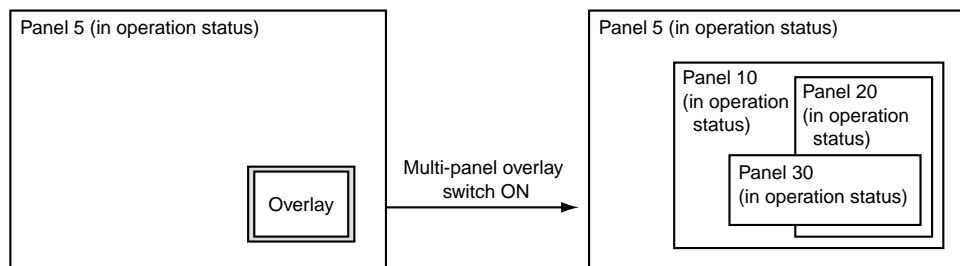

■ **Smart Object Parameters**

Tab name	Parameter name	Selection/setting item	Remarks
Basic	Mode	Select multi-panel overlay.	
	SW comm	Select when using switch communications.	
	Interlock	Select when using interlocked operation.	
Design	Type	Select the graphic type from general/user.	
	No.	Select the display graphic.	
	Color	Select the display color of the graphic.	
	Font size	Select the font size from 8 and 16 dots.	
	V alignment	Select vertical alignment from top/center/bottom.	
	H alignment	Select horizontal alignment from left/center/right.	
	Horizontal scale	Enter the horizontal scale of the string.	1 to 8
	Vertical scale	Enter the vertical scale of the string.	1 to 8
	Display string	Enter the display color.	
Text color	Enter the display text color.		
Panel	No.1 call panel	Enter the panel No. to be started up.	1 to 899
	No.1 coordinates	Enter the call coordinates of the panel to be started up.	
	No.2 call panel	Enter the panel No. to be started up.	0 to 899
	No.2 coordinates	Enter the call coordinates of the panel to be started up.	
	No.3 call panel	Enter the panel No. to be started up.	0 to 899
	No.3 coordinates	Enter the call coordinates of the panel to be started up.	
Switch communications	Switch code	Enter the switch code.	-32768 to +32767
	Switch communications function	Select the switch communications function.	
Interlock	Bit state	Interlock action according to ON/OFF state of bit device	
	Range	Interlock action according to bit device range	

■ Supplementary Explanation

- To start up two panels, specify “0” as the panel No. of No.3.
- Panels are started up in order from the No.1 specified panel. Accordingly, the last started up panel is displayed on top when the panel display areas are overlapping.
- There is no change to operation of the background panel.
- For details on smart object settings, see “2-2 Main Configuration Items for Smart Objects” (page 2-5).

! Handling Precautions

- Up to eight panels including the background panel can be started up simultaneously.
- When an opened pop-up panel is active, other panels cannot be started by this smart object.
- When “User” is selected at Graphic type and registered graphics are used for the switch graphic, the smart object size becomes the size of the graphic, and the smart object cannot be scaled.

Smart object name	Panel change switch, background panel selector [others]					
Type	Panel change switches					
	Scaling				Paste coordinates	
	Enlarge	Reduce	Reshape	Scaling factor		Text size
	○	○	○	Any	Fixed	Any

■ **Function**

- This smart object starts up the specified panel as the background panel, and closes the currently active background panel when a switch is touched.
- Each of the call coordinates of the panels to be started up can be specified.

■ **Configuration**

● **Basic**

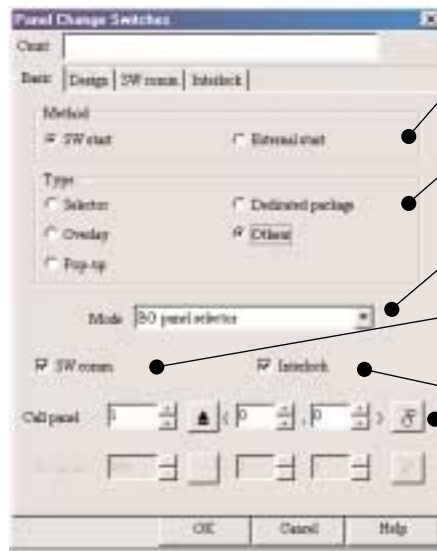

- [Method]**
This item is for selecting the startup method of panel selection. (panel change switch)
- [Type]**
This item is for selecting the type of panel change switch operation. (others)
- [Mode]**
This item is for selecting the operation mode of the smart object. (background panel selector)
- [SW comm]**
Select this item when using switch communications functions.
- [Interlock]**
Select this item when using the interlock function.
- [Call panel]**
This item is for entering the startup panel No. and the panel call coordinates.

● **Design**

Set the switch graphic and the display string.

● **Switch Communications**

Set the operation of switch communications functions.

● **Interlock**

Set the entry enabled conditions for the switch.

■ Example

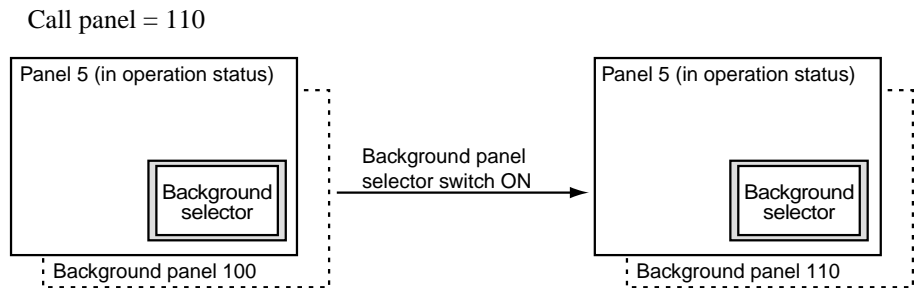

■ Smart Object Parameters

Tab name	Parameter name	Selection/setting item	Remarks
Basic	Mode	Select background selector.	
	Call panel	Enter the background panel No. to be started up.	1 to 899
	Coordinates	Enter the call coordinates of the background panel No. to be started up.	
	SW comm	Select when using switch communications.	
	Interlock	Select when using interlocked operation.	
Design	Type	Select the graphic type from general/user.	
	No.	Select the display graphic.	
	Color	Select the display color of the graphic.	
	Font size	Select the font size from 8 and 16 dots.	
	V alignment	Select vertical alignment from top/center/bottom.	
	H alignment	Select horizontal alignment from left/center/right.	
	Horizontal scale	Enter the horizontal scale of the string.	1 to 8
	Vertical scale	Enter the vertical scale of the string.	1 to 8
	Display string	Enter the display color.	
Text color	Enter the display text color.		
Switch communications	Switch code	Enter the switch code.	-32768 to +32767
	Switch communications function	Select the switch communications function.	
Interlock	Bit state	Interlock action according to ON/OFF state of bit device	
	Range	Interlock action according to bit device range	

■ Supplementary Explanation

- When selection of the background panel is executed, all active panels are restarted.
- For details on smart object settings, see “2-2 Main Configuration Items for Smart Objects” (page 2-5).

! Handling Precautions

- When an unregistered panel No. is entered, the panel is not opened even if the switch is touched.
- When an opened pop-up panel is active, other panels cannot be started by this smart object.
- This smart object does not function even if pasted to a background panel.
- When “User” is selected at Graphic type and registered graphics are used for the switch graphic, the smart object size becomes the size of the graphic, and the smart object cannot be scaled.

Smart object name	Panel change switch, background panel close [others]					
Type	Panel change switches					
	Scaling				Paste coordinates	
	Enlarge	Reduce	Reshape	Scaling factor		Text size
	<input type="radio"/>	<input type="radio"/>	<input type="radio"/>	Any	Fixed	Any

■ **Function**

- This smart panel stops operation of currently active background panels when a switch is touched.

■ **Configuration**

● **Basic**

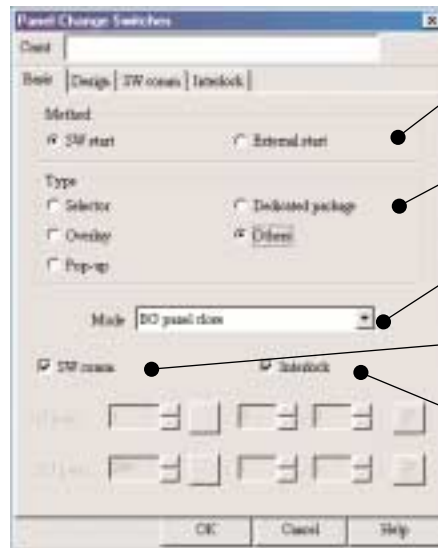

- [Method] This item is for selecting the startup method of panel selection. (panel change switch)
- [Type] This item is for selecting the type of panel change switch operation. (others)
- [Mode] This item is for selecting the operation mode of the smart object. (background panel close)
- [SW comm] Select this item when using switch communications functions.
- [Interlock] Select this item when using the interlock function.

● **Design**

Set the switch graphic and the display string.

● **Switch Communications**

Set the operation of switch communications functions.

● **Interlock**

Set the entry enabled conditions for the switch.

■ Example

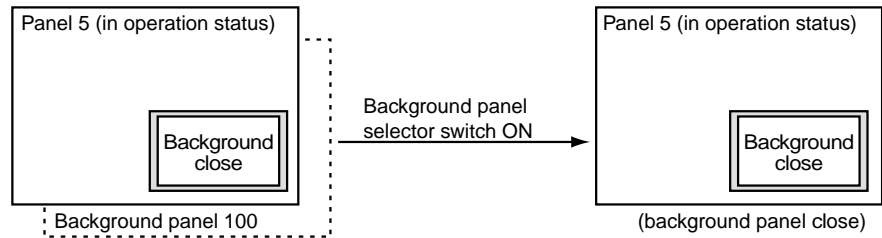

■ Smart Object Parameters

Tab name	Parameter name	Selection/setting item	Remarks
Basic	Mode	Select background panel close.	
	SW comm	Select when using switch communications.	
	Interlock	Select when using interlocked operation.	
Design	Type	Select the graphic type from general/user.	
	No.	Select the display graphic.	
	Color	Select the display color of the graphic.	
	Font size	Select the font size from 8 and 16 dots.	
	V alignment	Select vertical alignment from top/center/bottom.	
	H alignment	Select horizontal alignment from left/center/right.	
	Horizontal scale	Enter the horizontal scale of the string.	1 to 8
	Vertical scale	Enter the vertical scale of the string.	1 to 8
	Display string	Enter the display color.	
Switch communications	Text color	Enter the display text color.	
	Switch code	Enter the switch code.	-32768 to +32767
Interlock	Switch communications function	Select the switch communications function.	
	Bit state	Interlock action according to ON/OFF state of bit device	
	Range	Interlock action according to bit device range	

■ Supplementary Explanation

- When closing of the background panel is executed, all active panels are restarted.
- For details on smart object settings, see “2-2 Main Configuration Items for Smart Objects” (page 2-5).

! Handling Precautions

- There is no operation when background panels are not active.
- Background panels cannot be closed when a started up pop-up panel is currently active.
- This smart object does not function even if pasted to a background panel.
- When “User” is selected at Graphic type and registered graphics are used for the switch graphic, the smart object size becomes the size of the graphic, and the smart object cannot be scaled.

Smart object name	Panel change switch, panel selector (background change menu) [others]					
Type	Panel change switches					
	Scaling				Paste coordinates	
	Enlarge	Reduce	Reshape	Scaling factor		Text size
	○	○	○	Any	Fixed	Any

■ **Function**

- This smart object starts up the specified panel, and closes the startup source panel and other active panels.
- It also starts up the specified background panel, and closes the currently active background panel.
- Each of the call coordinates of the panels to be started up can be specified.

■ **Configuration**

● **Basic**

The screenshot shows the 'Panel Change Switches' dialog box with the following settings and callouts:

- [Method]**: Points to the 'SW start' radio button. Description: This item is for selecting the startup method of panel selection. (panel change switch)
- [Type]**: Points to the 'Selector' radio button. Description: This item is for selecting the type of panel change switch operation. (others)
- [Mode]**: Points to the 'Mode' dropdown menu, which is set to 'Panel selector (BG change)'. Description: This item is for selecting the operation mode of the smart object. (panel selector (BG change))
- [SW comm]**: Points to the 'SW comm' checkbox. Description: Select this item when using switch communications functions.
- [Interlock]**: Points to the 'Interlock' checkbox. Description: Select this item when using the interlock function.
- [Call panel]**: Points to the 'Call panel' input fields. Description: This item is for entering the startup panel No. and the panel call coordinates.
- [Background panel]**: Points to the 'BG panel' input fields. Description: This item is for entering the startup background panel No. and the call coordinates of the panel.

● **Design**

Set the switch graphic and the display string.

● **Switch Communications**

Set the operation of switch communications functions.

● **Interlock**

Set the entry enabled conditions for the switch.

■ Example

Call panel = 10, background panel = 110

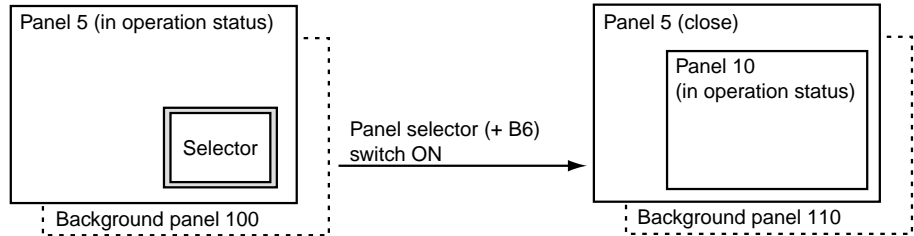

■ Smart Object Parameters

Tab name	Parameter name	Selection/setting item	Remarks
Basic	Mode	Select panel selector (+BG).	
	Call panel	Enter the panel No. to be started up.	1 to 899
	Coordinates	Enter the call coordinates of the panel to be started up.	
	Background panel	Enter the background panel No. to be started up.	1 to 899
	Coordinates	Enter the call coordinates of the background panel No. to be started up.	
	SW comm	Select when using switch communications.	
	Interlock	Select when using interlocked operation.	
Design	Type	Select the graphic type from general/user.	
	No.	Select the display graphic.	
	Color	Select the display color of the graphic.	
	Font size	Select the font size from 8 and 16 dots.	
	V alignment	Select vertical alignment from top/center/bottom.	
	H alignment	Select horizontal alignment from left/center/right.	
	Horizontal scale	Enter the horizontal scale of the string.	1 to 8
	Vertical scale	Enter the vertical scale of the string.	1 to 8
	Display string	Enter the display color.	
Text color	Enter the display text color.		
Switch communications	Switch code	Enter the switch code.	-32768 to +32767
	Switch communications function	Select the switch communications function.	
Interlock	Bit state	Interlock action according to ON/OFF state of bit device	
	Range	Interlock action according to bit device range	

■ Supplementary Explanation

- When selection of the background panel is executed, all active panels are restarted.
- For details on smart object settings, see “2-2 Main Configuration Items for Smart Objects” (page 2-5).

! Handling Precautions

- When an unregistered panel No. is entered, the panel is not opened even if the switch is touched.
- When an opened pop-up panel is active, other panels cannot be started by this smart object.
- This smart object does not function even if pasted to a background panel.
- When “User” is selected at Graphic type and registered graphics are used for the switch graphic, the smart object size becomes the size of the graphic, and the smart object cannot be scaled.

Smart object name	Panel change switch, panel selector (background close) [others]					
Type	Panel change switches					
	Scaling				Paste coordinates	
	Enlarge	Reduce	Reshape	Scaling factor		Text size
	○	○	○	Any	Fixed	Any

Function

- This smart object starts up the specified panel, and closes the startup source panel and other active panels.
- It also closes the currently active background panel.
- Each of the call coordinates of the panels to be started up can be specified.

Configuration

● **Basic**

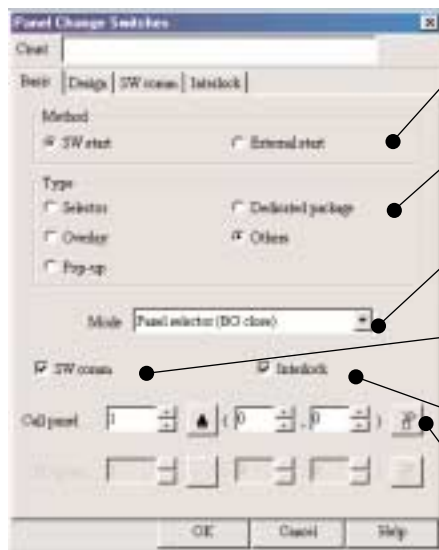

- [Method]**
This item is for selecting the startup method of panel selection. (panel change switch)
- [Type]**
This item is for selecting the type of panel change switch operation. (others)
- [Mode]**
This item is for selecting the operation mode of the smart object. (panel selector (BG close))
- [SW comm]**
Select this item when using switch communications functions.
- [Interlock]**
Select this item when using the interlock function.
- [Call panel]**
This item is for entering the startup panel No. and the panel call coordinates.

● **Design**

Set the switch graphic and the display string.

● **Switch Communications**

Set the operation of switch communications functions.

● **Interlock**

Set the entry enabled conditions for the switch.

■ Example

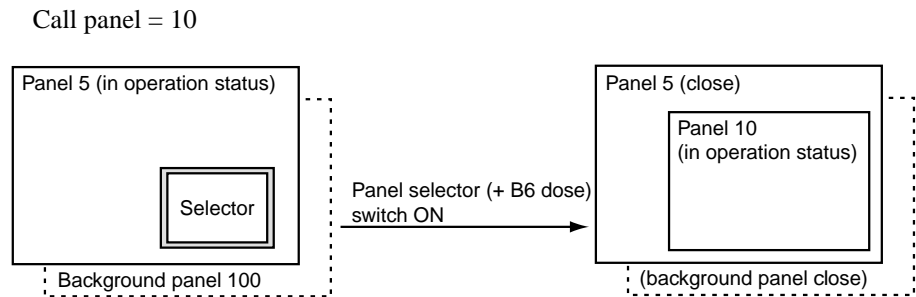

■ Smart Object Parameters

Tab name	Parameter name	Selection/setting item	Remarks
Basic	Mode	Select panel selector (+BG close).	
	Call panel	Enter the panel No. to be started up.	1 to 899
	Coordinates	Enter the call coordinates of the panel to be started up.	
	SW comm	Select when using switch communications.	
	Interlock	Select when using interlocked operation.	
Design	Type	Select the graphic type from general/user.	
	No.	Select the display graphic.	
	Color	Select the display color of the graphic.	
	Font size	Select the font size from 8 and 16 dots.	
	V alignment	Select vertical alignment from top/center/bottom.	
	H alignment	Select horizontal alignment from left/center/right.	
	Horizontal scale	Enter the horizontal scale of the string.	1 to 8
	Vertical scale	Enter the vertical scale of the string.	1 to 8
	Display string	Enter the display color.	
Text color	Enter the display text color.		
Switch communications	Switch code	Enter the switch code.	-32768 to +32767
	Switch communications function	Select the switch communications function.	
Interlock	Bit state	Interlock action according to ON/OFF state of bit device	
	Range	Interlock action according to bit device range	

■ Supplementary Explanation

- When closing of the background panel is executed, all active panels are restarted.
- For details on smart object settings, see “2-2 Main Configuration Items for Smart Objects” (page 2-5).

! Handling Precautions

- When an unregistered panel No. is entered, the panel is not opened even if the switch is touched.
- When an opened pop-up panel is active, other panels cannot be started by this smart object.
- This smart object does not function even if pasted to a background panel.
- When “User” is selected at Graphic type and registered graphics are used for the switch graphic, the smart object size becomes the size of the graphic, and the smart object cannot be scaled.

Smart object name	Panel change switch, panel close [others]					
Type	Panel change switches					
	Scaling					Paste coordinates
	Enlarge	Reduce	Reshape	Scaling factor	Text size	
	<input type="radio"/>	<input type="radio"/>	<input type="radio"/>	Any	Fixed	Any

■ **Function**

- This smart object stops the self panel, and closes the panel display.
- Other active panels stay active.

■ **Configuration**

● **Basic**

[Method]
This item is for selecting the startup method of panel selection. (panel change switch)

[Type]
This item is for selecting the type of panel change switch operation. (others)

[Mode]
This item is for selecting the operation mode of the smart object. (panel close)

[SW comm]
Select this item when using switch communications functions.

[Interlock]
Select this item when using the interlock function.

● **Design**

Set the switch graphic and the display string.

● **Switch Communications**

Set the operation of switch communications functions.

● **Interlock**

Set the entry enabled conditions for the switch.

■ Example

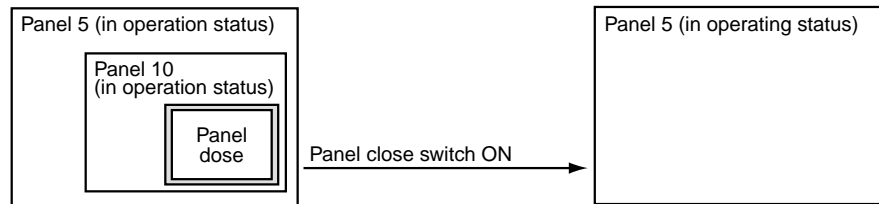

■ Smart Object Parameters

Tab name	Parameter name	Selection/setting item	Remarks
Basic	Mode	Select panel close.	
	SW comm	Select when using switch communications.	
	Interlock	Select when using interlocked operation.	
Design	Type	Select the graphic type from general/rocker/slide/user.	
	No.	Select the display graphic.	
	Color	Select the display color of the graphic.	
	Font size	Select the font size from 8 and 16 dots.	
	V alignment	Select vertical alignment from top/center/bottom.	
	H alignment	Select horizontal alignment from left/center/right.	
	Horizontal scale	Enter the horizontal scale of the string.	1 to 8
	Vertical scale	Enter the vertical scale of the string.	1 to 8
	Display string	Enter the display color.	
	Text color	Enter the display text color.	
Switch communications	Switch code	Enter the switch code.	-32768 to +32767
	Switch communications function	Select the switch communications function.	
Interlock	Bit state	Interlock action according to ON/OFF state of bit device	
	Range	Interlock action according to bit device range	

■ Supplementary Explanation

- This smart object is used to close multiple panels opened by overlay, for example.
- There is no change to operation of the background panel.
- For details on smart object settings, see “2-2 Main Configuration Items for Smart Objects” (page 2-5).

! Handling Precautions

- Active pop-up panels cannot be closed by this smart object.
- This smart object does not function when a started up pop-up panel is currently active.
- Panels cannot be closed by this smart object when there is only one active panel.
- When “User” is selected at Graphic type and registered graphics are used for the switch graphic, the smart object size becomes the size of the graphic, and the smart object cannot be scaled.

Smart object name	Panel change switch, panel replace [others]					
Type	Panel change switches					
	Scaling				Paste coordinates	
	Enlarge	Reduce	Reshape	Scaling factor		Text size
	○	○	○	Any	Fixed	Any

■ **Function**

- This smart object closes the startup source panel, and starts up the specified panel. Other active panels remain active.
- Each of the call coordinates of the panels to be started up can be specified.

■ **Configuration**

● **Basic**

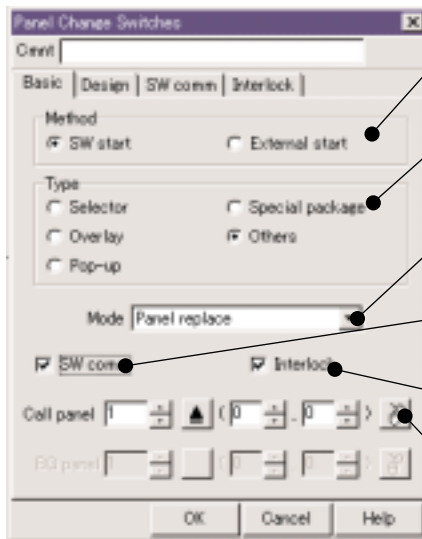

- [Method]**
This item is for selecting the startup method of panel selection. (panel change switch)
- [Type]**
This item is for selecting the type of panel change switch operation. (others)
- [Mode]**
This item is for selecting the operation mode of the smart object. (panel replace)
- [SW comm]**
Select this item when using switch communications functions.
- [Interlock]**
Select this item when using the interlock function.
- [Call panel]**
This item is for entering the startup panel No. and the panel call coordinates.

● **Design**

Set the switch graphic and the display string.

● **Switch Communications**

Set the operation of switch communications functions.

● **Interlock**

Set the entry enabled conditions for the switch.

■ Example

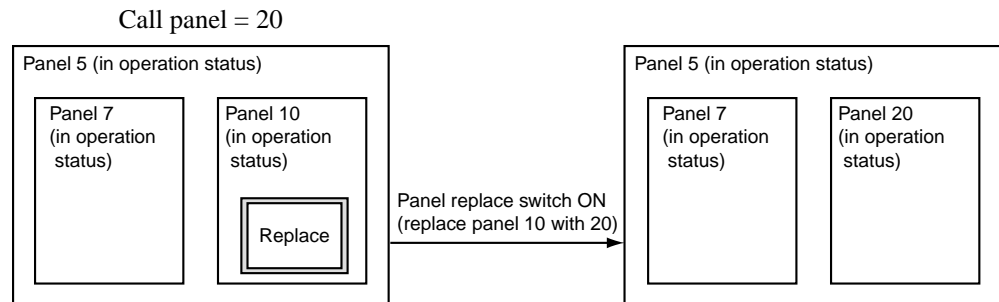

■ Smart Object Parameters

Tab name	Parameter name	Selection/setting item	Remarks
Basic	Mode	Select panel replace.	
	Call panel	Enter the panel No. to be started up.	1 to 899
	Coordinates	Enter the call coordinates of the panel to be started up.	
	SW comm	Select when using switch communications.	
	Interlock	Select when using interlocked operation.	
Design	Type	Select the graphic type from general/user.	
	No.	Select the display graphic.	
	Color	Select the display color of the graphic.	
	Font size	Select the font size from 8 and 16 dots.	
	V alignment	Select vertical alignment from top/center/bottom.	
	H alignment	Select horizontal alignment from left/center/right.	
	Horizontal scale	Enter the horizontal scale of the string.	1 to 8
	Vertical scale	Enter the vertical scale of the string.	1 to 8
	Display string	Enter the display color.	
Text color	Enter the display text color.		
Switch communications	Switch code	Enter the switch code.	-32768 to +32767
	Switch communications function	Select the switch communications function.	
Interlock	Bit state	Interlock action according to ON/OFF state of bit device	
	Range	Interlock action according to bit device range	

■ Supplementary Explanation

- Screens other than the newly started up panel stay displayed, however their operations are suspended.
- There is no change to operation of the background panel.
- For details on smart object settings, see “2-2 Main Configuration Items for Smart Objects” (page 2-5).

! Handling Precautions

- When an unregistered panel No. is entered, there is no operation.
- When an opened pop-up panel is active, other panels cannot be started by this smart object.
- This smart object does not function even if pasted to a background panel.
- When “User” is selected at Graphic type and registered graphics are used for the switch graphic, the smart object size becomes the size of the graphic, and the smart object cannot be scaled.

Smart object name	Panel change switch, panel to front [others]					
Type	Panel change switches					
	Scaling				Paste coordinates	
	Enlarge	Reduce	Reshape	Scaling factor		Text size
	<input type="radio"/>	<input type="radio"/>	<input type="radio"/>	Any	Fixed	Any

■ **Function**

- This smart object displays the self panel at the front. Other active panels remain active.

■ **Configuration**

● **Basic**

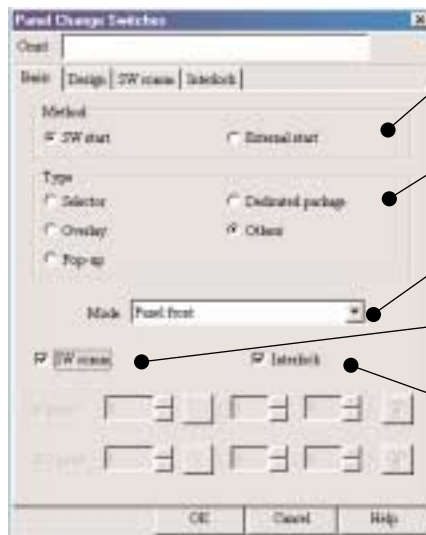

[Method]
This item is for selecting the startup method of panel selection. (panel change switch)

[Type]
This item is for selecting the type of panel change switch operation. (others)

[Mode]
This item is for selecting the operation mode of the smart object. (panel front)

[SW comm]
Select this item when using switch communications functions.

[Interlock]
Select this item when using the interlock function.

● **Design**

Set the switch graphic and the display string.

● **Switch Communications**

Set the operation of switch communications functions.

● **Interlock**

Set the entry enabled conditions for the switch.

■ Example

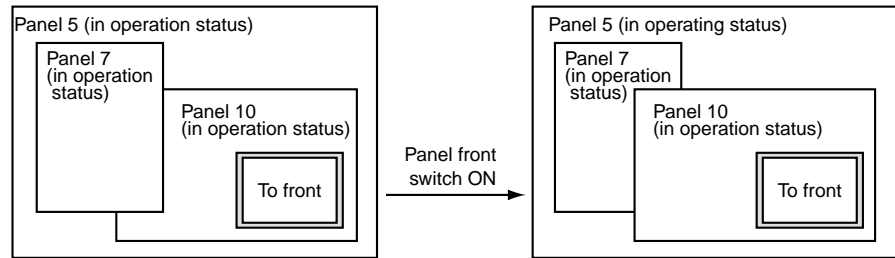

■ Smart Object Parameters

Tab name	Parameter name	Selection/setting item	Remarks
Basic	Mode	Select panel to front.	
	SW comm	Select when using switch communications.	
	Interlock	Select when using interlocked operation.	
Design	Type	Select the graphic type from general/user.	
	No.	Select the display graphic.	
	Color	Select the display color of the graphic.	
	Font size	Select the font size from 8 and 16 dots.	
	V alignment	Select vertical alignment from top/center/bottom.	
	H alignment	Select horizontal alignment from left/center/right.	
	Horizontal scale	Enter the horizontal scale of the string.	1 to 8
	Vertical scale	Enter the vertical scale of the string.	1 to 8
	Display string	Enter the display color.	
	Text color	Enter the display text color.	
Switch communications	Switch code	Enter the switch code.	-32768 to +32767
	Switch communications function	Select the switch communications function.	
Interlock	Bit state	Interlock action according to ON/OFF state of bit device	
	Range	Interlock action according to bit device range	

■ Supplementary Explanation

- There is no change to operation of the background panel.
- For details on smart object settings, see “2-2 Main Configuration Items for Smart Objects” (page 2-5).

! Handling Precautions

- When an opened pop-up panel is active, panels cannot be started by this smart object.
- When “User” is selected at Graphic type and registered graphics are used for the switch graphic, the smart object size becomes the size of the graphic, and the smart object cannot be scaled.

Smart object name	External, panel selector				
Type	Panel change switches				
	Scaling				Paste coordinates
	Enlarge	Reduce	Reshape	Scaling factor	Text size
				—	—
					Any

■ Function

- This smart object enables panels to be forcibly selected from the PLC.
- It also starts up the specified panel, and closes the startup source panel and other active panels.
- The call coordinates of the panel to be started up can be specified.

■ Configuration

● Basic

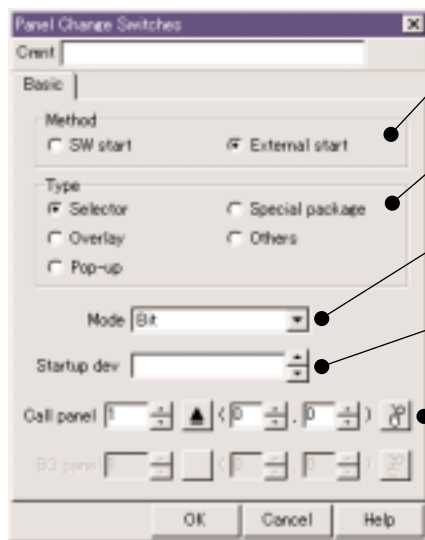

- [Method]
This item is for selecting the startup method of panel selection. (external)
- [Type]
This item is for selecting the type of panel change switch operation. (panel selector)
- [Mode]
This item is for selecting the operation mode of the smart object.
- [Startup device]
This item is for entering the PLC device for starting up the panel selector when "Bit" has been selected at Mode.
- [Call panel]
This item is for entering the startup panel No. and call coordinates of the panel when "Bit" has been selected at Mode.

- Mode
Select the operation mode of the panel selector from "Bit" type and "Word" type.
[Bit]
The specified panel is started up, and the startup source panel and other active panels are closed when the bit device on the PLC is activated.
When a panel is selected, the EST turns the bits of the startup device to OFF.
[Word]
By entering the panel No. to panel device on the PLC, that specified panel is started up, and the startup source panel and other active panels are closed.
When a panel is selected, the EST resets the panel device to "0".
- Startup device
Enter the bit device on the PLC that is to be used as the panel selector trigger when "Bit type" has been selected at Mode.
- Call panel
Enter the No. of the panel to be started up and its call coordinates when the startup device is activated.

● Panel

This sheet is for setting the word device on the PLC to which panel data is stored and the call coordinates of the panel when “Word” is selected at Mode.

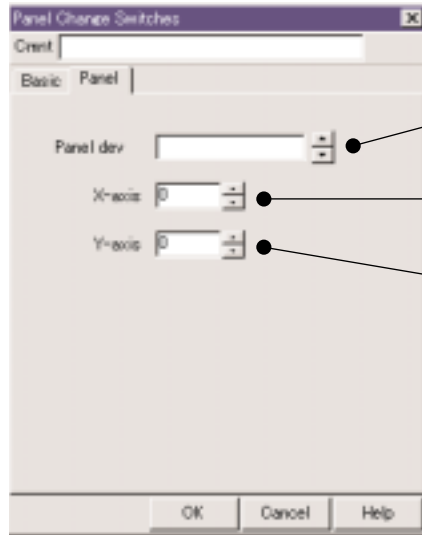

- [Panel device]
This item is for entering the panel selector device when “Word type” is selected at Mode.
- [X-axis]
This item is for entering the X coordinates of the call panel.
- [Y-axis]
This item is for entering the Y coordinates of the call panel.

■ Example
● Bit type

Startup device = M010, call panel = 10, call coordinates = (20, 20)

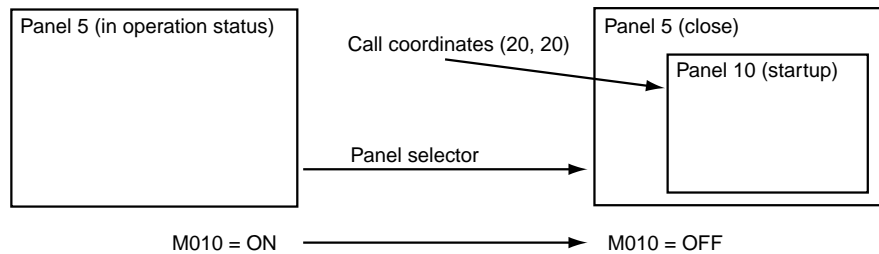

● Word type

Panel device = D100, call coordinates = (40, 40)

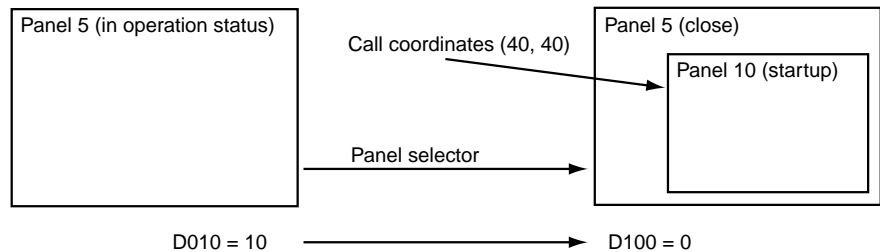

■ Smart Object Parameters

Tab name	Parameter name	Selection/setting item	Remarks
Basic	Mode	Select the operation mode from bit type/word type.	
	Startup device	Enter the communications channel, the device address, and the bit device.	When bit type is selected
	Call panel	Enter the panel No. to be started up.	When bit type is selected: 1 to 899
	Coordinates	Enter the call coordinates of the panel to be started up.	When bit type is selected
Panel	Panel device	Enter the communications channel, the device address, and the word device.	When word type is selected
	X-axis	Enter the X coordinates of the panel to be started up.	When word type is selected: 0 to 319
	Y-axis	Enter the Y coordinates of the panel to be started up.	When word type is selected: 0 to 239

■ Supplementary Explanation

- Screens other than the newly started up panel stay displayed, however their operations are suspended.
- There is no change to operation of the background panel.
- This is a transparent smart object, and may be pasted anywhere.
- When “Word type” is selected at Mode, set the data to be set to the panel device within the binary data range 1 to 899.

! Handling Precautions

- When “Bit” is selected at Mode, the panel is not selected if an unregistered panel No. is entered. The EST, however, turns the startup device OFF.
- When “Word” is selected at Mode, the panel is not selected if a panel No. not registered to the panel device is entered. The EST, however, resets the panel device to “0”. Note, however, that when panel No.0 or 900 or above has been specified, the data of the panel device is not set to “0”.
- When an opened pop-up panel is active, other panels cannot be started by this smart object.
- To execute panel selection by this smart object, execute setting of the data to the startup device or panel device by one-shot instructions. One-shot instructions may not function properly on circuits that are executed at all times.

[Bit type]

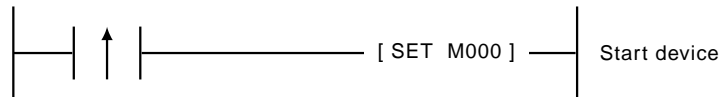

[Word type]

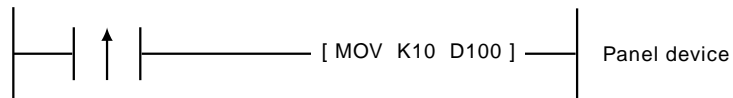

Smart object name	External, panel overlay					
Type	Panel change switches					
	Scaling				Paste coordinates	
	Enlarge	Reduce	Reshape	Scaling factor		Text size
				—	—	Any

■ Function

- This smart object enables panels to be forcibly overlaid from the PLC.
- It also starts up the specified panel. The startup source panel and other active panels stay active.
- The call coordinates of the panel to be started up can be specified.

■ Configuration

● Basic

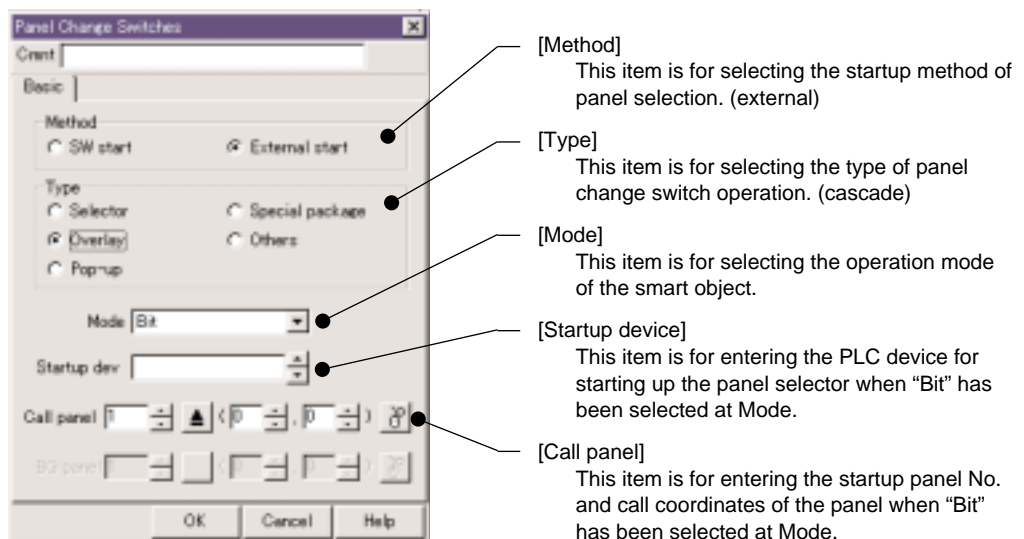

- **Mode**
Select the operation mode of the panel selector from "Bit" type and "Word" type.
[Bit]
The specified panel is started up, when the bit device on the PLC is activated. The startup source panel and other active panels stay active. When a panel is selected, the EST turns the bits of the startup device to OFF.
[Word]
By entering the panel No. to panel device on the PLC, that specified panel is started up. The startup source panel and other active panels stay active. When a panel is selected, the EST resets the panel device to "0".
- **Startup device**
Enter the bit device on the PLC that is to be used as the panel selector trigger when "Bit" has been selected at Mode.

● Panel

This sheet is for setting the word device on the PLC to which panel data is stored and the call coordinates of the panel when “Word” is selected at Mode.

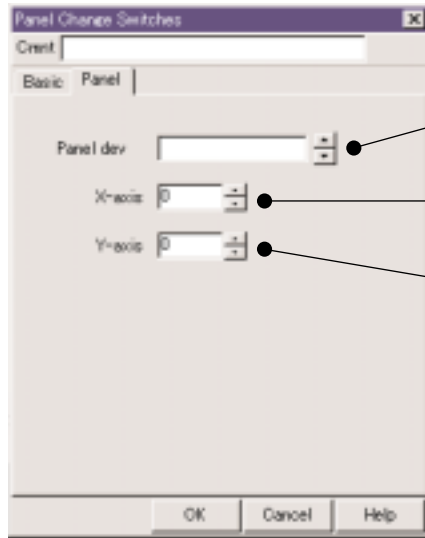

- [Panel device]
This item is for entering the panel selector device when “Word type” is selected at Mode.
- [X-axis]
This item is for entering the X coordinates of the call panel.
- [Y-axis]
This item is for entering the Y coordinates of the call panel.

■ Example
● Bit type

Startup device = M010, call panel = 10, call coordinates = (20, 20)

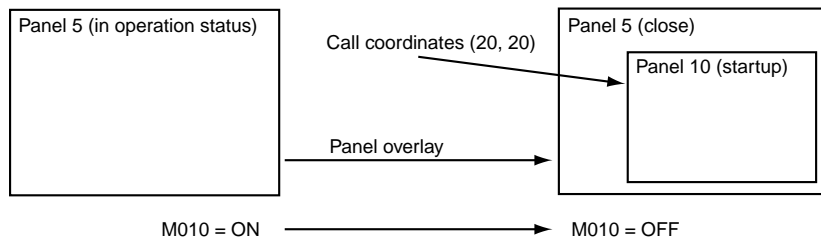

● Word type

Panel device = D100, call coordinates = (40, 40)

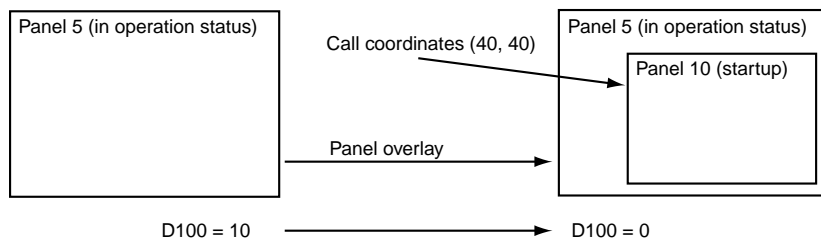

■ Smart Object Parameters

Tab name	Parameter name	Selection/setting item	Remarks
Basic	Mode	Select the operation mode from bit type/word type.	
	Startup device	Enter the communications channel, the device address, and the bit device.	When bit type is selected
	Call panel	Enter the panel No. to be started up.	When bit type is selected: 1 to 899
	Coordinates	Enter the call coordinates of the panel to be started up.	When bit type is selected
Panel	Panel device	Enter the communications channel, the device address, and the word device.	When word type is selected
	X-axis	Enter the X coordinates of the panel to be started up.	When word type is selected: 0 to 319
	Y-axis	Enter the Y coordinates of the panel to be started up.	When word type is selected: 0 to 239

■ Supplementary Explanation

- Use the following smart objects to close a started panel.

Smart object type	Smart object name	Function
Panel change switches	Switch start, panel selector	Starts up the specified panels, and stops all other currently active panels.
	External start, panel selector	Executes the panel selector by the PLC device.
	Switch start, panel close	Stops the own panel.
	External start, panel close	Stops the specified panel by the PLC device.

- There is no change to operation of the background panel.
- This is a transparent smart object, and may be pasted anywhere.
- When “Word type” is selected at Mode, set the data to be set to the panel device within the binary data range 1 to 899.

! Handling Precautions

- When “Bit” is selected at Mode, the panel is not selected if an unregistered panel No. is entered. The EST, however, turns the startup device OFF.
- When “Word” is selected at Mode, the panel is not selected if a panel No. not registered to the panel device is entered. The EST, however, resets the panel device to “0”. Note, however, that when panel No.0 or 900 or above has been specified, the data of the panel device is not set to “0”.
- When an opened pop-up panel is active, other panels cannot be started by this smart object.
- To execute panel selection by this smart object, execute setting of the data to the startup device or panel device by one-shot instructions. One-shot instructions may not function properly on circuits that are executed at all times.

[Bit type]

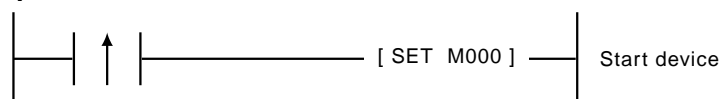

[Word type]

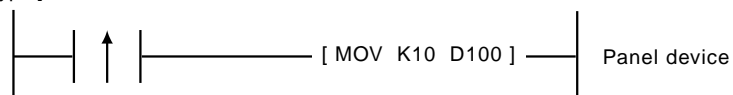

Smart object name	External, open pop-up				
Type	Panel change switches				
	Scaling				Paste coordinates
	Enlarge	Reduce	Reshape	Scaling factor	Text size
				—	—
					Any

■ **Function**

● **Startup**

- This smart object forcibly causes the specified panel to pop up and start from the PLC.
- It also causes the specified panel to pop up when the startup device is activated, and closes the startup source panel and closes other active panels. Note, however, that when this smart object is started up from a background panel, the background panel does not close.
- The call coordinates of the panel to be started up can be specified.

● **Return**

- This smart object forcibly clears the active pop-up panel from the PLC.
- It also clears the active pop-up panel when the startup device is activated, and returns to the state before the panel was activated.
- This smart object is pasted to the panel to be started up.

■ **Configuration**

● **Basic**

[Method]
This item is for selecting the startup method of panel selection. (external)

[Type]
This item is for selecting the type of panel change switch operation. (pop-up)

[Mode]
This item is for selecting the operation mode of the smart object from Pop-up /Return.

[Startup device]
This item is for entering the PLC device for starting up the panel selector.

[Call panel]
This item is for entering the startup panel No. and call coordinates of the panel.

■ Example

Call panel = 10, startup device: startup = M000/Return = M001

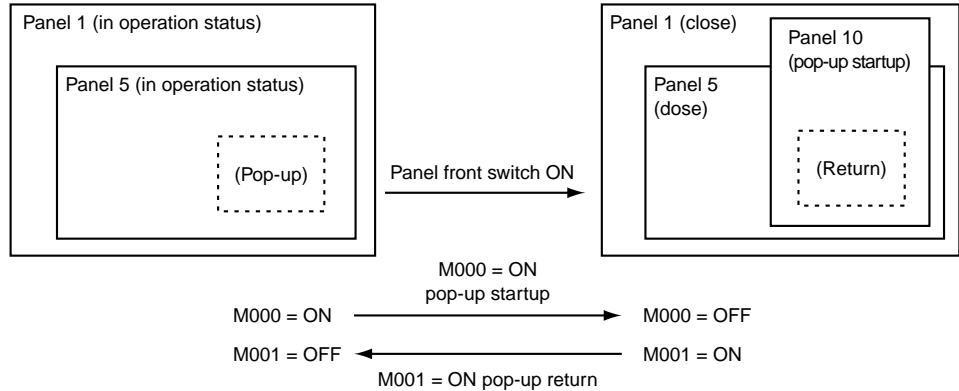

■ Smart Object Parameters

Tab name	Parameter name	Selection/setting item	Remarks
Basic	Mode	Select the pop-up action from pop-up/return.	
	Startup device	Enter the communications channel, the device address, and the bit device.	
	Call panel	Enter the panel No. to be started up.	When open pop-up is selected 1 to 899
	Coordinates	Enter the call coordinates of the panel to be started up.	

■ Supplementary Explanation

- The EST turns the startup device OFF at pop-up startup/return.
- Pop-up return is used only to close an active pop-up panel.
- The panel setting is not available when pop-up return is selected.
- There is no change to operation of the background panel.
- This is a transparent smart object, and may be pasted anywhere.

! Handling Precautions

- If an unregistered panel No. is entered to the call panel when pop-up startup is selected, nothing happens. The EST, however, turns the startup device OFF.
- If there is no active pop-up panel when pop-up return is selected, nothing happens. The EST, however, turns the startup device OFF.
- This smart object does not function when an open pop-up panel is active.
- Set pop-up return smart objects to the panel to be started up. Open active pop-up panels cannot be cleared by other smart objects.
- Execute setting of the startup device bits by one-shot instructions. One-shot instructions may not function properly on circuits that set bits to ON at all times.

[Ladder circuit example]

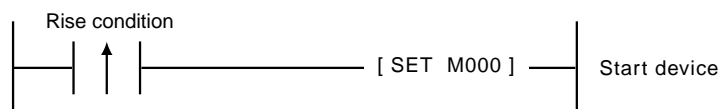

3-4 Panel Change Switches

Smart object name	External, special package selector					
Type	Panel change switches					
	Scaling				Paste coordinates	
	Enlarge	Reduce	Reshape	Scaling factor		Text size
				—	—	Any

■ Function

- This smart object forcibly switches the panel to the special package from the PLC.
- It also starts up the special package, and closes the startup source panel and other active panels.

■ Configuration

● Basic

[Method]
This item is for selecting the startup method of panel selection. (external start)

[Type]
This item is for selecting the type of panel change switch operation. (special package)

[Startup device]
This item is for entering the PLC device for starting up the panel selector.

■ Example

Startup device = M000



■ Smart Object Parameters

Tab name	Parameter name	Selection/setting item	Remarks
Basic	Startup device	Enter the communications channel, the device address, and the bit device.	

■ Supplementary Explanation

- “Special packages” are library software packages such as the DMC10 package prepared by Yamatake. They cannot be created nor modified.
For details on special packages, refer to Smart Terminal EST240Z User's Manual Application Preparation Manual No.CP-SP-1088E.
For details on the DMC10 package, refer to Smart Terminal EST240Z User's Manual DMC10 Package Manual No.CP-SP-1091E.
- The EST turns the startup device OFF at panel selection.
- This is a transparent smart object, and may be pasted anywhere.
- There is no change to operation of the background panel.

! Handling Precautions

- When the special package is not being downloaded to the EST, nothing happens. The EST, however, turns the startup device OFF.
- Panels cannot be started up when a started up pop-up panel is currently active.
- Execute setting of the startup device bits by one-shot instructions. One-shot instructions may not function properly on circuits that set bits to ON at all times.

[Ladder circuit example]

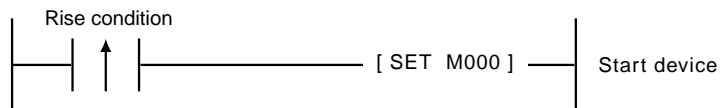

Smart object name	External, multi-panel selector [others]					
Type	Panel change switches					
	Scaling				Paste coordinates	
	Enlarge	Reduce	Reshape	Scaling factor		Text size
				—	—	Any

■ **Function**

- This smart object forcibly selects panels from the PLC.
- This smart object starts up a maximum of three panels simultaneously. It also closes the startup source panel and other active panels.
- Each of the call coordinates of the panels to be started up can be specified.

■ **Configuration**

● **Basic**

[Method]
This item is for selecting the startup method of panel selection. (external)

[Type]
This item is for selecting the type of panel change switch operation. (others)

[Mode]
This item is for selecting the operation mode of the smart object. (multi-panel selector)

[Startup device]
This item is for entering the PLC device for starting up the panel selector.

● **Panel**

[Startup panels No.1/2/3]
This item is for selecting up to three panels to be started up.

■ Example

Startup device = M000, call panel: No.1 = 10, No.2 = 20, No.3 = 30

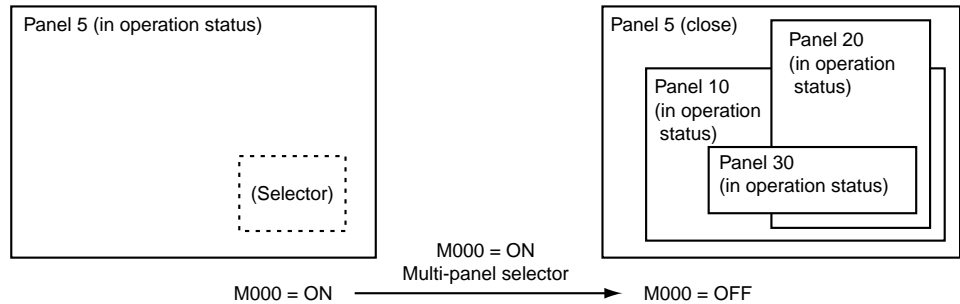

■ Smart Object Parameters

Tab name	Parameter name	Selection/setting item	Remarks
Basic	Mode	Select multi-panel selector.	
	Startup device	Enter the communications channel, the device address, and the bit device.	
Panel	No.1 call panel	Enter the panel No. to be started up.	1 to 899
	No.1 coordinates	Enter the call coordinates of the panel to be started up.	
	No.2 call panel	Enter the panel No. to be started up.	0 to 899
	No.2 coordinates	Enter the call coordinates of the panel to be started up.	
	No.3 call panel	Enter the panel No. to be started up.	0 to 899
	No.3 coordinates	Enter the call coordinates of the panel to be started up.	

■ Supplementary Explanation

- The EST turns the startup device OFF at panel selection.
- Screens other than the newly started up panel stay displayed, however their operations are suspended.
- To start up two panels, specify “0” as the panel No. of No.3.
- Panels are started up in order from the No.1 specified panel. Accordingly, the last started up panel is displayed on top when the panel display areas are overlapping.
- This is a transparent smart object, and may be pasted anywhere.
- There is no change to operation of the background panel.

! Handling Precautions

- When an unregistered panel No. is entered, the panel does not change. The EST, however, turns the startup device OFF.
- If the panels specified by panel No.1, 2 and 3 do not exist, all panel operations other than the background panel are suspended.
- Panels cannot be started up when a started up pop-up panel is currently active.
- Execute setting of the startup device bits by one-shot instructions. One-shot instructions may not function properly on circuits that set bits to ON at all times.

[Ladder circuit example]

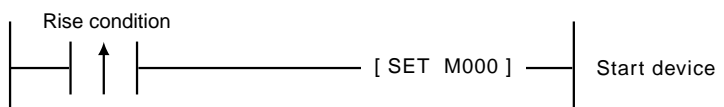

Smart object name	External, multi-panel overlay [others]					
Type	Panel change switches					
	Scaling				Paste coordinates	
	Enlarge	Reduce	Reshape	Scaling factor		Text size
				—	—	Any

■ **Function**

- This smart object forcibly selects panels from the PLC.
- This smart object starts up a maximum of three panels simultaneously. It also closes the startup source panel and other active panels.
- Each of the call coordinates of the panels to be started up can be specified.

■ **Configuration**

● **Basic**

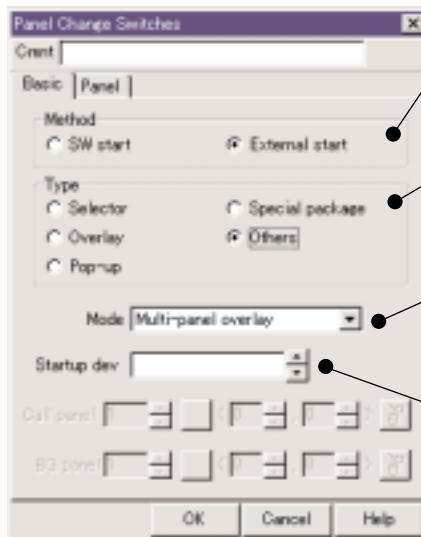

- [Method]
This item is for selecting the startup method of panel selection. (external start)
- [Type]
This item is for selecting the type of panel change switch operation. (others)
- [Mode]
This item is for selecting the operation mode of the smart object. (multi-panel overlay)
- [Startup device]
This item is for entering the device for starting up the panel selector.

● **Panel**

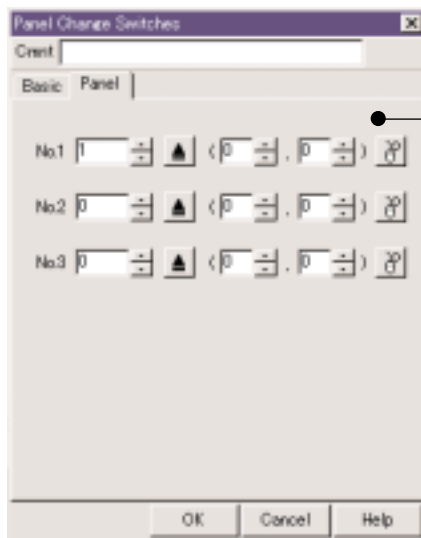

- [Startup panels No.1/2/3]
This item is for selecting up to three panels to be started up.

■ Example

Startup device = M000, call panel: No.1 = 10, No.2 = 20, No.3 = 30

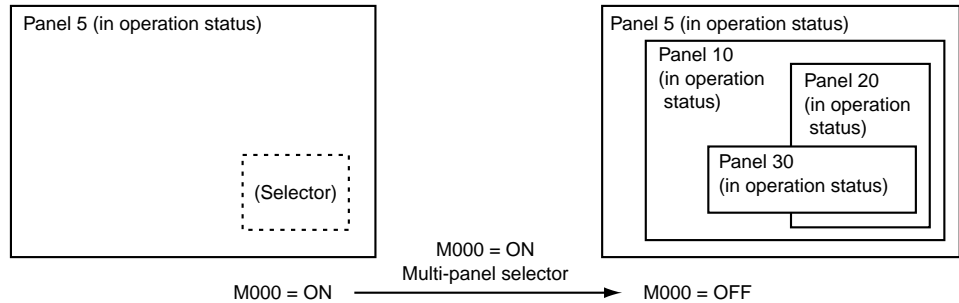

■ Smart Object Parameters

Tab name	Parameter name	Selection/setting item	Remarks
Basic	Mode	Select multi-panel overlay.	
	Startup device	Enter the communications channel, the device address, and the bit device.	
Panel	No.1 call panel	Enter the panel No. to be started up.	1 to 899
	No.1 coordinates	Enter the call coordinates of the panel to be started up.	
	No.2 call panel	Enter the panel No. to be started up.	0 to 899
	No.2 coordinates	Enter the call coordinates of the panel to be started up.	
	No.3 call panel	Enter the panel No. to be started up.	0 to 899
	No.3 coordinates	Enter the call coordinates of the panel to be started up.	

■ Supplementary Explanation

- The EST turns the startup device OFF at panel selection.
- To start up two panels, specify “0” as the panel No. of No.3.
- Panels are started up in order from the No.1 specified panel. Accordingly, the last started up panel is displayed on top when the panel display areas are overlapping.
- This is a transparent smart object, and may be pasted anywhere.
- There is no change to operation of the background panel.

! Handling Precautions

- When an unregistered panel No. is entered, the panel is not started up. The EST, however, turns the startup device OFF.
- Panels cannot be started up when a started up pop-up panel is currently active.
- Execute setting of the startup device bits by one-shot instructions. One-shot instructions may not function properly on circuits that set bits to ON at all times.

[Ladder circuit example]

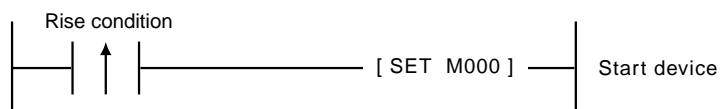

3-4 Panel Change Switches

Smart object name	External, background panel selector [others]					
Type	Panel change switches					
	Scaling				Paste coordinates	
	Enlarge	Reduce	Reshape	Scaling factor		Text size
				—	—	Any

■ Function

- This smart object forcibly selects the background panel from the PLC.
- It also starts up the specified panel as the background panel, and closes the currently active background panel.
- Each of the call coordinates of the panels to be started up can be specified.

■ Configuration

● Basic

The screenshot shows the 'Panel Change Switches' dialog box with the following callouts:

- [Method]**: This item is for selecting the startup method of panel selection. (external start)
- [Type]**: This item is for selecting the type of panel change switch operation. (other)
- [Mode]**: This item is for selecting the operation mode of the smart object. (BG panel selector)
- [Startup device]**: This item is for entering the PLC device for starting up selection of the background panel.
- [Call panel]**: This item is for entering the startup panel No. and the panel call coordinates.

■ Example

Startup device = M000, call panel = 110

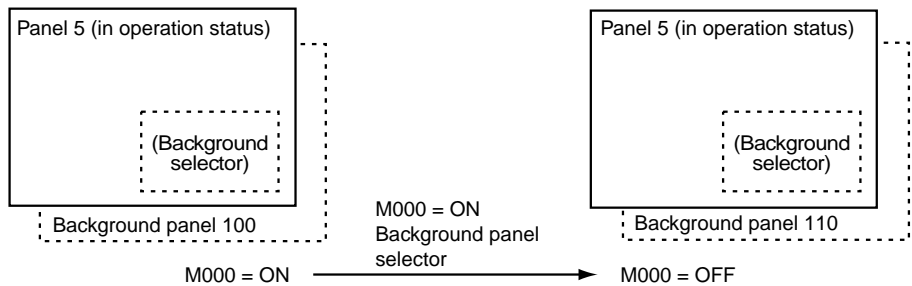

■ Smart Object Parameters

Tab name	Parameter name	Selection/setting item	Remarks
Basic	Mode	Select background selector.	
	Startup device	Enter the communications channel, the device address, and the bit device.	
	Call panel	Enter the background panel No. to be started up.	1 to 899
	Coordinates	Enter the call coordinates of the background panel No. to be started up.	

■ Supplementary Explanation

- The EST turns the startup device OFF at panel selection.
- This is a transparent smart object, and may be pasted anywhere.
- When selection of the background panel is executed, all active panels are restarted.

! Handling Precautions

- When an unregistered panel No. is entered, the panel startup is ignored. The EST, however, turns the startup device OFF.
- Panels cannot be started up when a started up pop-up panel is currently active.
- Execute setting of the startup device bits by one-shot instructions. One-shot instructions may not function properly on circuits that set bits to ON at all times.

[Ladder circuit example]

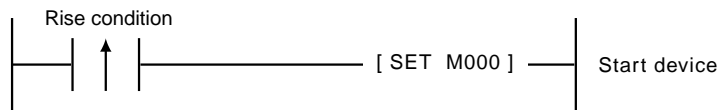

3-4 Panel Change Switches

Smart object name	External, background panel close [others]					
Type	Panel change switches					
	Scaling				Paste coordinates	
	Enlarge	Reduce	Reshape	Scaling factor		Text size
				—	—	Any

■ Function

- This smart object forcibly closes the background panel from the PLC.
- It also stops operation of currently active background panels.

■ Configuration

● Basic

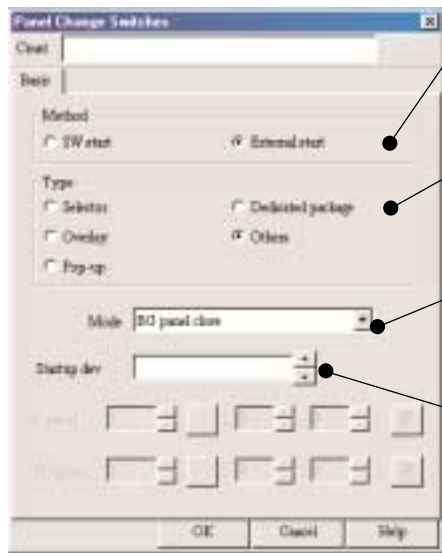

[Method]
This item is for selecting the startup method of panel selection. (external start)

[Type]
This item is for selecting the type of panel change switch operation. (others)

[Mode]
This item is for selecting the operation mode of the smart object. (BG panel close)

[Startup device]
This item is for entering the PLC device for stopping background panel operation.

■ Example

Startup device = M000

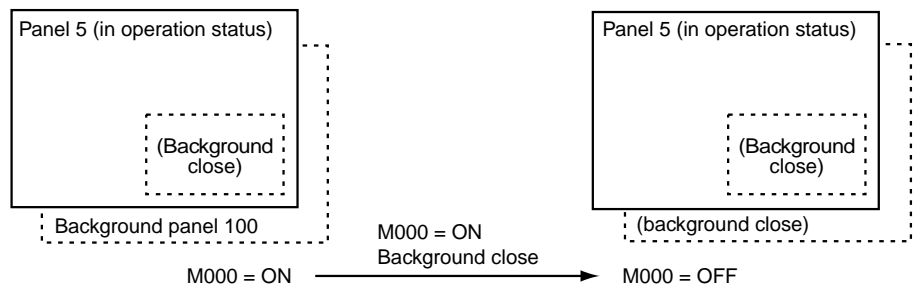

■ Smart Object Parameters

Tab name	Parameter name	Selection/setting item	Remarks
Basic	Mode	Select background panel close.	
	Startup device	Enter the communications channel, the device address, and the bit device.	

■ Supplementary Explanation

- The EST turns the startup device OFF at panel selection.
- This is a transparent smart object, and may be pasted anywhere.
- When closing of the background panel is executed, all active panels are restarted.

! Handling Precautions

- There is no operation when background panels are not active. The EST, however, turns OFF the startup device.
- Background panels cannot be closed when a started up pop-up panel is currently active.
- This smart object does not function even if pasted to a background panel.
- Execute setting of the startup device bits by one-shot instructions. One-shot instructions may not function properly on circuits that set bits to ON at all times.

[Ladder circuit example]

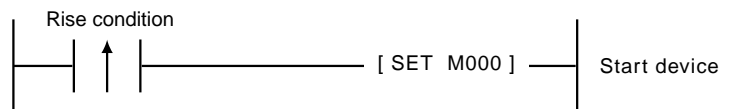

Smart object name	External, panel selector (background change menu) [others]					
Type	Panel change switches					
	Scaling				Paste coordinates	
	Enlarge	Reduce	Reshape	Scaling factor		Text size
				—	—	Any

■ **Function**

- This smart object forcibly selects the panel from the PLC.
- It also starts up the specified panel, and closes the startup source panel and other active panels.
- It also starts up the specified background panel, and closes currently active background panels.
- Each of the call coordinates of the panels to be started up can be specified.

■ **Configuration**

● **Basic**

The screenshot shows the 'Panel Change Switches' dialog box with the following settings and callouts:

- [Method]:** Points to the 'Method' section where 'IF External start' is selected.
- [Type]:** Points to the 'Type' section where 'Others' is selected.
- [Mode]:** Points to the 'Mode' dropdown menu set to 'Panel selector (BG change)'.
- [Startup dev]:** Points to the 'Startup dev' text box.
- [Call panel]:** Points to the 'Call panel' input fields.
- [Background panel]:** Points to the 'BG panel' input fields.

■ **Example**

Startup device = M000, call panel = 10, background panel = 110

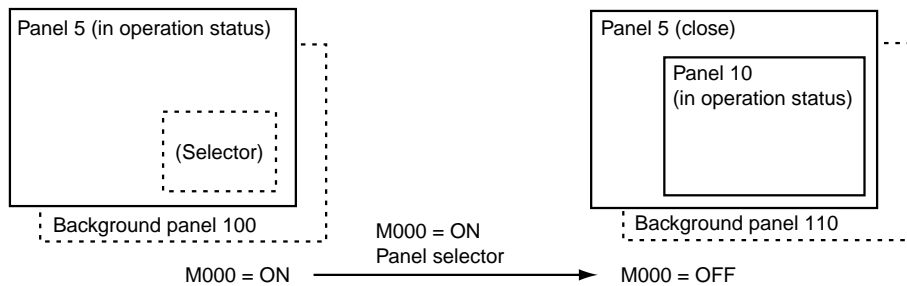

■ Smart Object Parameters

Tab name	Parameter name	Selection/setting item	Remarks
Basic	Mode	Select panel selector (BG change).	
	Startup device	Enter the communications channel, the device address, and the bit device.	
	Call panel	Enter the panel No. to be started up.	1 to 899
	Coordinates	Enter the call coordinates of the panel to be started up.	
	Background panel	Enter the background panel No. to be started up.	1 to 899
	Coordinates	Enter the call coordinates of the background panel No. to be started up.	

■ Supplementary Explanation

- The EST turns the startup device OFF at panel selection.
- When selection of the background panel is executed, all active panels are restarted.
- This is a transparent smart object, and may be pasted anywhere.

! Handling Precautions

- When an unregistered panel No. is entered, the panel startup is ignored. The EST, however, turns the startup device OFF.
- Panels cannot be started up when a started up pop-up panel is currently active.
- This smart object does not function even if pasted to a background panel.
- Execute setting of the startup device bits by one-shot instructions. One-shot instructions may not function properly on circuits that set bits to ON at all times.

[Ladder circuit example]

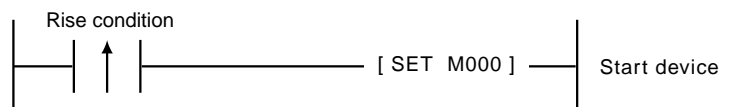

Smart object name	External, panel selector (background close) [others]					
Type	Panel change switches					
	Scaling				Paste coordinates	
	Enlarge	Reduce	Reshape	Scaling factor		Text size
				—	—	Any

■ **Function**

- This smart object forcibly selects the panel from the PLC.
- It also starts up the specified panel, and closes the startup source panel and other active panels.
- It also stops operation of currently active background panels.
- Each of the call coordinates of the panels to be started up can be specified.

■ **Configuration**

● **Basic**

The screenshot shows the 'Panel Change Switches' dialog box with the following settings and callouts:

- [Method]:** Points to the 'External start' radio button. Description: This item is for selecting the startup method of panel selection. (external start)
- [Type]:** Points to the 'Others' radio button. Description: This item is for selecting the type of panel change switch operation. (others)
- [Mode]:** Points to the 'Mode' dropdown menu, which is set to 'Panel selector (BG close)'. Description: This item is for selecting the operation mode of the smart object. (panel selector (BG close))
- [Startup device]:** Points to the 'Startup dev' text box. Description: This item is for entering the PLC device for starting up the panel.
- [Call panel]:** Points to the 'Call panel' text box. Description: This item is for entering the startup panel No. and the panel call coordinates.

■ **Example**

Startup device = M000, call panel = 10

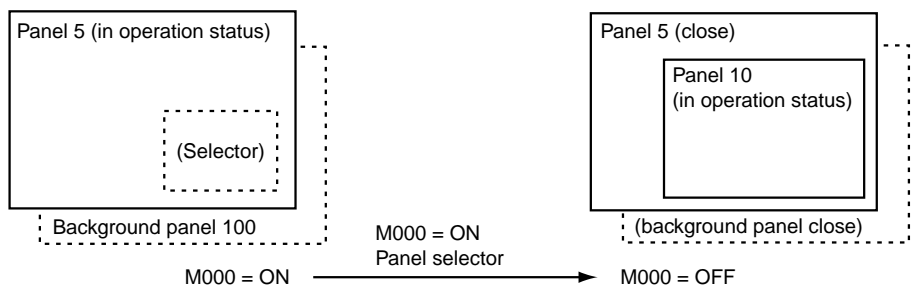

■ Smart Object Parameters

Tab name	Parameter name	Selection/setting item	Remarks
Basic	Mode	Select panel selector (BG close).	
	Startup device	Enter the communications channel, the device address, and the bit device.	
	Call panel	Enter the panel No. to be started up.	1 to 899
	Coordinates	Enter the call coordinates of the panel to be started up.	

■ Supplementary Explanation

- The EST turns the startup device OFF at panel selection.
- When selection of the background panel is executed, all active panels are restarted.
- This is a transparent smart object, and may be pasted anywhere.

! Handling Precautions

- When an unregistered panel No. is entered, the panel startup is ignored. The EST, however, turns the startup device OFF.
- Panels cannot be started up when a started up pop-up panel is currently active.
- This smart object does not function even if pasted to a background panel.
- Execute setting of the startup device bits by one-shot instructions. One-shot instructions may not function properly on circuits that set bits to ON at all times.

[Ladder circuit example]

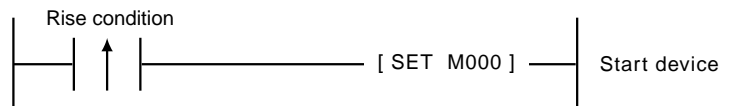

Smart object name	External, panel close [others]					
Type	Panel change switches					
	Scaling				Paste coordinates	
	Enlarge	Reduce	Reshape	Scaling factor		Text size
				—	—	Any

■ **Function**

- This smart object forcibly closes the panel from the PLC.
- This smart object stops the specified panel, and closes the panel display.
- Other active panels stay active.

■ **Configuration**

● **Basic**

[Method]
This item is for selecting the startup method of panel selection. (external start)

[Type]
This item is for selecting the type of panel change switch operation. (others)

[Mode]
This item is for selecting the operation mode of the smart object. (panel close)

[Startup device]
This item is for entering the PLC device for starting up smart object operation.

[Clear panel]
This item is for entering the clear panel No.

■ **Example**

Startup device = M000, clear panel = 20

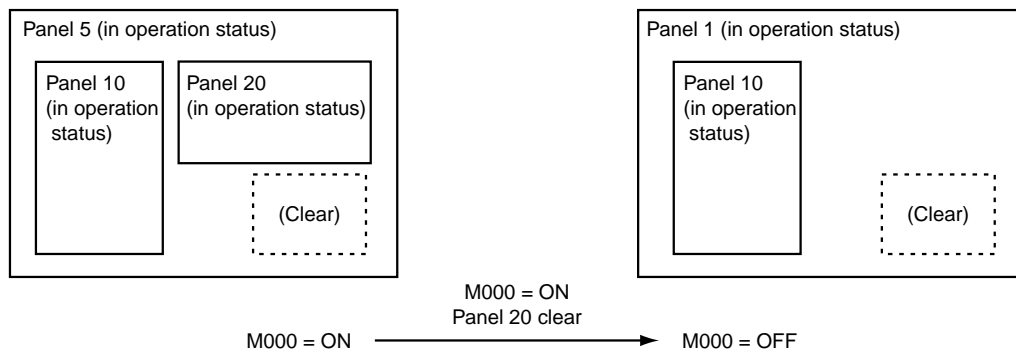

■ Smart Object Parameters

Tab name	Parameter name	Selection/setting item	Remarks
Basic	Mode	Select panel close.	
	Startup device	Enter the communications channel, the station address, and the bit device.	
	Clear panel	Enter the panel No. to be started up.	1 to 899

■ Supplementary Explanation

- The EST turns the startup device OFF at panel selection.
- This smart object is used to close multiple panels opened by overlay, for example.
- There is no change to operation of the background panel.
- This is a transparent smart object, and may be pasted anywhere.

❗ Handling Precautions

- Panels cannot be closed by this smart object when there is only one active panel.
- When an unregistered panel No. is entered, the panel clear is ignored. The EST, however, turns the startup device OFF.
- Panels cannot be closed by this smart object when there is only one active panel.
- This smart object does not function when an open pop-up panel is active.
- Execute setting of the startup device bits by one-shot instructions. One-shot instructions may not function properly on circuits that set bits to ON at all times.

[Ladder circuit example]

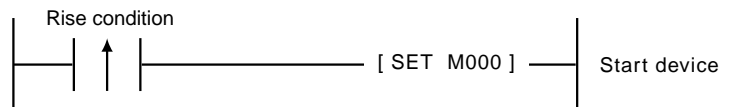



3 - 5 Lamps

Smart object name	Bit type 2-state lamp				
Type	Lamps				
Scaling					Paste coordinates
Enlarge	Reduce	Reshape	Scaling factor	Text size	
<input type="radio"/>	<input type="radio"/>	<input type="radio"/>	Any	Fixed	Any

Function

- Lamp graphics are switched according to the ON/OFF state of the lamp device on the PLC.

Configuration

Basic

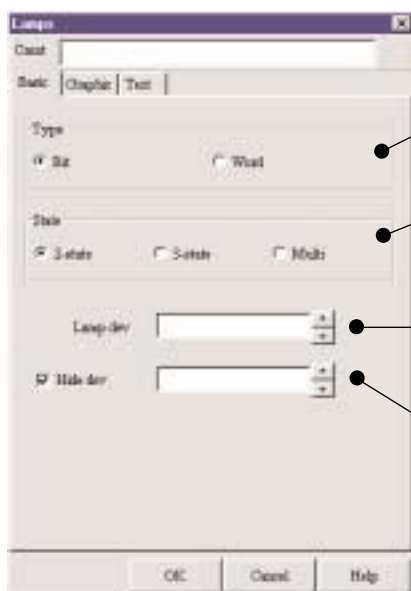

- [Type]**
This item is used for selecting the lamp type.
- [State]**
This item is used for selecting the operation function of the lamp smart object.
- [Lamp device]**
This item is for entering the bit device to be monitored for switching graphic or text display.
- [Hide device]**
This item is for entering the bit device for clearing the graphic or text display.

Graphic

Set the graphic at OFF/graphic at ON to be displayed on the smart object and the display color of the graphic.

Text

Set the string at OFF/ON to be displayed on the smart object and the display text color of the string.

Example

Lamp device = M001

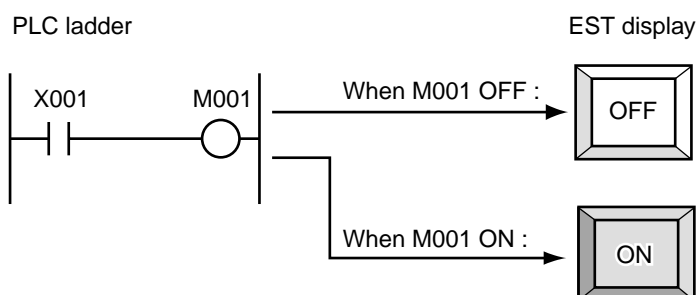

■ Smart Object Parameters

Tab name	Parameter name	Selection/setting item	Remarks
Basic	Lamp device	Enter the communications channel, the device address, and the bit device.	
	Hide device	Enter the communications channel, the device address, and the bit device.	
Graphic	Type	Select the graphic type according to general/piping lamp/user.	
	OFF Graphic	Select the display graphic when the lamp is OFF.	
	Color when OFF	Select the display color of the graphic when the lamp is OFF.	
	Blink when OFF	Select to cause blinking when the lamp is OFF.	
	ON Graphic	Select the display graphic when the lamp is ON.	
	Color when ON	Select the display color of the graphic when the lamp is ON.	
	Blink when ON	Select to cause blinking when the lamp is ON.	
Text	Font size	Select the font size from 8 and 16 dots.	
	V alignment	Select vertical alignment from top/center/bottom.	
	H alignment	Select horizontal alignment from left/center/right.	
	Horizontal scale	Enter the horizontal scale of the string.	1 to 8
	Vertical scale	Enter the vertical scale of the string.	1 to 8
	OFF string	Enter the display text when the lamp is OFF.	
	OFF color	Enter the display text color when the lamp is OFF.	
	Blink when OFF	Select to cause blinking when the lamp is OFF.	
	ON string	Select the display text when the lamp is ON.	
	ON color	Select the display text color when the lamp is ON.	
	Blink when ON	Select to cause blinking when the lamp is ON.	

■ Supplementary Explanation

- Select Graphic at OFF for the graphic selection when a lamp device is used. Graphic at OFF is paired with Graphic at ON and is automatically selected. Note, however, that Graphic at OFF/Graphic at ON can be freely selected from registered graphics when “User” has been selected at Graphic type.
- For details on smart object settings, see “2-2 Main Configuration Items for Smart Objects” (page 2-5).

! Handling Precautions

- Enter the bit device on the PLC for the Lamp/Hide device. Do not enter word devices such as registers.
- When a registered graphic is used for the lamp graphic, the OFF graphic and ON graphic to be displayed must be created at the same size.
- When a registered graphic is used for the lamp graphic, the smart object size becomes the size of the graphic, and the smart object cannot be scaled.

Smart object name	Bit type 3-state lamp				
Type	Lamps				
Scaling					Paste coordinates
Enlarge	Reduce	Reshape	Scaling factor	Text size	
<input type="radio"/>	<input type="radio"/>	<input type="radio"/>	Any	Fixed	Any

■ **Function**

- Lamp graphics are changed according to the ON/OFF state of the lamp device (state 1/2/3) on the PLC.
- The following table shows the display of lamp graphics according to the ON/OFF state of the 3-bit lamp device.

EST display	State 1 device	State 2 device	State 1 device
No display	OFF	OFF	OFF
State 1	ON	OFF	OFF
State 2	--- *	ON	OFF
State 3	--- *	---	ON

*: May be either ON or OFF.

■ **Configuration**

● **Basic**



[Type]

This item is used for selecting the lamp type.

[State]

This item is used for selecting the operation function of the lamp smart object.

[State 1/2/3 device]

This item is for entering the bit device to be monitored for switching graphic or text display.

● **Graphic**

Set the display graphic in states 1/2/3 and the display color of that graphic.

● **Text**

Set the display string in states 1/2/3 and the display color of that text.

■ Example

State 1 device = M000, state 2 device = M002, state 3 device = M010

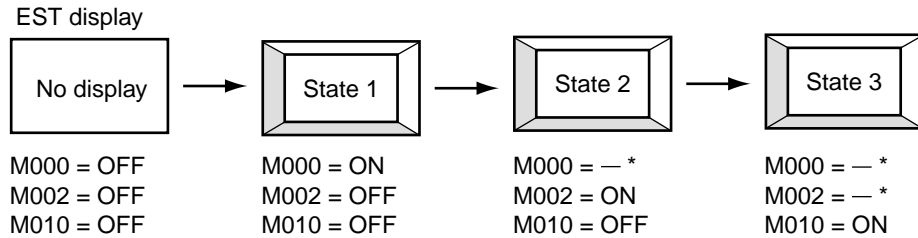

* Either of ON or OFF is acceptable.

■ Smart Object Parameters

Tab name	Parameter name	Selection/setting item	Remarks
Basic	State 1 device	Enter the communications channel, the device address, and the bit device.	
	State 2 device	Enter the communications channel, the device address, and the bit device.	
	State 3 device	Enter the communications channel, the device address, and the bit device.	
Graphic	Type	Select the graphic type according to general/piping lamp/user.	
	State 1 No.	Select the display graphic of state 1.	
	State 1 Color	Select the display graphic color of state 1.	
	State 2 No.	Select the display graphic of state 2.	
	State 2 Color	Select the display graphic color of state 2.	
	Blink in state 2	Select to cause blinking in state 2.	Blinking with graphic 1
	State 3 No.	Select the display graphic of state 3.	
	State 3 Color	Select the display graphic color of state 3.	
	Blink in state 3	Select to cause blinking in state 3.	Blinking with graphic 1
Text	Font size	Select the font size from 8 and 16 dots.	
	V alignment	Select vertical alignment from top/center/bottom.	
	H alignment	Select horizontal alignment from left/center/right.	
	Horizontal scale	Enter the horizontal scale of the string.	1 to 8
	Vertical scale	Enter the vertical scale of the string.	1 to 8
	State 1 string	Enter the display text of state 1.	
	State 1 text color	Select the display text color of state 1.	
	State 2 string	Enter the display text of state 2.	
	State 2 text color	Select the display text color of state 2.	
	Blink in state 2	Select to cause blinking in state 2.	Blinking of text color
	State 3 string	Enter the display text of state 3.	
	State 3 text color	Select the display text color of state 3.	
		Blink in state 3	Select to cause blinking in state 3.

■ Supplementary Explanation

- The order of priority of lamp devices is State 1 < State 2 < State 3.
When a device bit having a higher priority is ON, the bit state of lower priority bits is ignored.
- Blinking of graphics is performed alternately between blinking of the state 1 graphic and blinking of the state 2/3 graphic.
- Blinking of strings is performed alternately between blinking of the state 1 string and blinking of the state 2/3 string. The string currently set to state 2/3 is displayed as the text to be displayed.
- For details on smart object settings, see “2-2 Main Configuration Items for Smart Objects” (page 2-5).

! Handling Precautions

- Enter the bit device on the PLC for the State 1/2/3 device. Do not enter word devices such as registers.
- When a registered graphic is used for the lamp graphic, all state 1/2/3 graphics must be created at the same size.
- When a registered graphic is used for the lamp graphic, the smart object size becomes the size of the graphic, and the smart object cannot be scaled.

Smart object name	Bit type multi-value state lamp				
Type	Lamps				
Scaling					Paste coordinates
Enlarge	Reduce	Reshape	Scaling factor	Text size	
			—	—	Any

■ **Function**

- This smart object selects display of up to 15 graphics according to the ON/OFF state of the lamp device on the PLC.

■ **Configuration**

● **Basic**

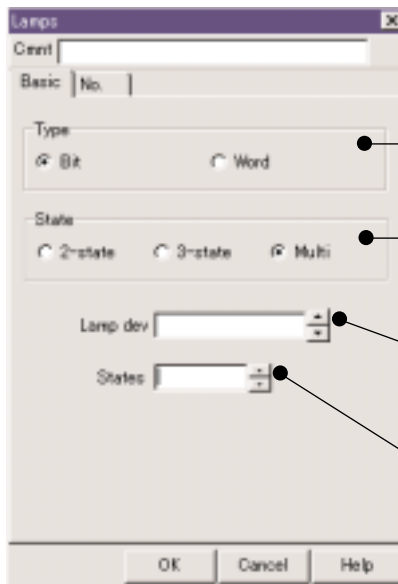

- [Type]
This item is used for selecting the lamp type.
- [State]
This item is used for selecting the operation function of the lamp smart object.
- [Lamp device]
This item is for entering the start bit device to be monitored for switching graphic or text display.
- [States]
This item is for entering the number of graphic states.

- Lamp device
Set the start lamp device bit. Lamp devices are monitored from the bit device set at Lamp device for the number of display states entered at Number of states.

● **No.**

The graphic No. is the graphic specified to correspond with the start lamp device. Create registered graphics in advance using a continuous graphic No. for the number of states to be displayed.

■ Example

Lamp device = M000, number of states = 3, graphic No. = 10

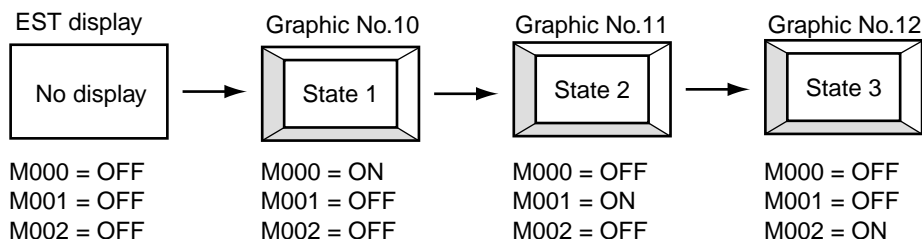

■ Smart Object Parameters

Tab name	Parameter name	Selection/setting item	Remarks
Basic	Lamp device	Enter the start communications channel, the device address, and the bit device.	
	States	Enter the number of states to be displayed.	2 to 15
Graphic	Type	User	
	No.	Enter the start graphic No. to be displayed.	

■ Supplementary Explanation

- Lamp bits and display graphics are paired together.
- For details on smart object settings, see “2-2 Main Configuration Items for Smart Objects” (page 2-5).

! Handling Precautions

- Enter the bit device on the PLC for the Lamp device. Do not enter word devices such as registers.
- Do not turn multiple bits ON simultaneously as the bit device for lamp devices. Doing so may prevent correct display.
- The graphic type selection is specified only for “User.” The graphic type selection is not available for “General.”
- Create all graphics at the same size.
- The smart object size becomes the size of the graphic, and the smart object cannot be scaled.

Smart object name	Word type 2-state lamp						
Type	Lamps						
				Scaling		Paste coordinates	
Enlarge		Reduce		Reshape	Scaling factor		Text size
<input type="radio"/>		<input type="radio"/>		<input type="radio"/>	Any	Fixed	Any

■ **Function**

- Lamp graphics are switched according to the data range of the lamp device on the PLC.

■ **Configuration**

● **Basic**

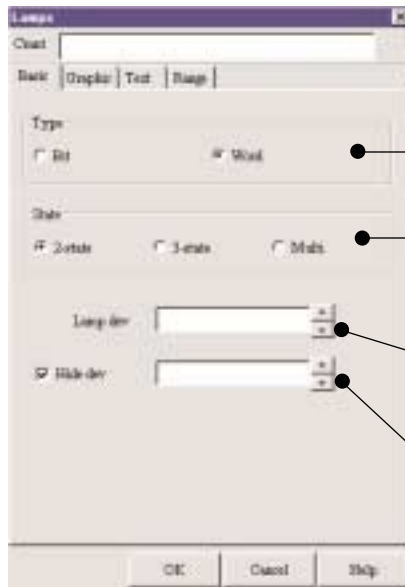

- [Type] This item is used for selecting the lamp type.
- [State] This item is used for selecting the operation function of the lamp smart object.
- [Lamp device] This item is for entering the word device to be monitored for switching graphic or text display.
- [Hide device] This item is for entering the bit device for clearing the graphic or text display.

● **Graphic**

Set the graphic at OFF/graphic at ON to be displayed on the smart object and the display color of the graphic.

● **Text**

Set the string at OFF/ON to be displayed on the smart object and the display text color of the string.

● Range

Set the data range of ON/OFF display for the lamp device.

[Lamp ON range]
This item is used for selecting the ON display range for the lamp.

[Data format]
This item is for selecting the data format of the value currently stored to the lamp device.

[Upper/lower value]
This item is for entering the upper/lower limit values of the range selected at Lamp ON range.

• Lamp ON range

Select the data range of the lamp device for executing lamp ON display.

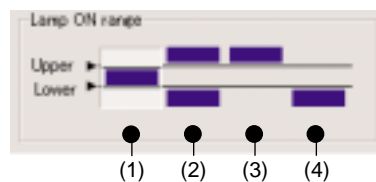

Lamp ON state display range

- (1) Upper limit value \geq Lamp device \geq Lower limit value
- (2) Lamp device \geq Upper limit value, or Lamp device \leq Lower limit value
- (3) Lamp device \geq Upper limit value
- (4) Lamp device \leq Lower limit value

• Range

Set the display range (upper/lower limit values) of the ON state as the data range of the lamp device.

■ Example

Lamp device = D100, lamp ON range = Upper limit value \geq Lamp device \geq Lower limit value, Upper limit value = 1000, Lower limit value = 500

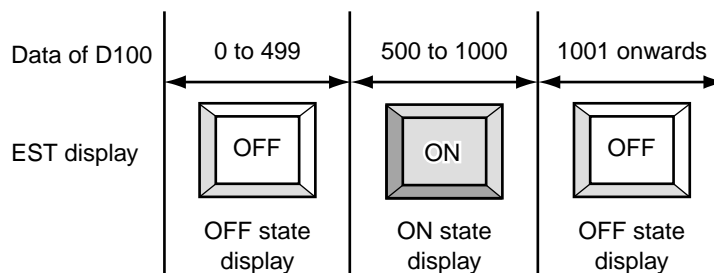

■ Smart Object Parameters

Tab name	Parameter name	Selection/setting item	Remarks
Basic	Lamp device	Enter the communications channel, the device address, and the word device.	
	Hide device	Enter the communications channel, the device address, and the bit device.	
Graphic	Type	Select the graphic type according to general/piping lamp/user.	
	OFF Graphic	Select the display graphic when the lamp is OFF.	
	Color when OFF	Select the display color of the graphic when the lamp is OFF.	
	Blink when OFF	Select to cause blinking when the lamp is OFF.	
	ON Graphic	Select the display graphic when the lamp is ON.	
	Color when ON	Select the display color of the graphic when the lamp is ON.	
	Blink when ON	Select to cause blinking when the lamp is ON.	
Text	Font size	Select the font size from 8 and 16 dots.	
	V alignment	Select vertical alignment from top/center/bottom.	
	H alignment	Select horizontal alignment from left/center/right.	
	Horizontal scale	Enter the horizontal scale of the string.	1 to 8
	Vertical scale	Enter the vertical scale of the string.	1 to 8
	OFF string	Enter the display text when the lamp is OFF.	
	OFF color	Enter the display text color when the lamp is OFF.	
	Blink when OFF	Select to cause blinking when the lamp is OFF.	
	ON string	Select the display text when the lamp is ON.	
	ON color	Select the display text color when the lamp is ON.	
	Blink when ON	Select to cause blinking when the lamp is ON.	
Range	Lamp ON range	Select the ON state display range of the lamp.	
	Data format	Select the data format of the lamp device data.	
	Upper value	Enter the upper limit value of the lamp ON range.	
	Lower value	Enter the lower limit value of the lamp ON range.	

■ Supplementary Explanation

- Select Graphic at OFF for the graphic selection when a lamp device is used. Graphic at OFF is paired with Graphic at ON and is automatically selected. Note, however, that Graphic at OFF/Graphic at ON can be freely selected from registered graphics when “User” has been selected at Graphic type.
- PLC devices can also be set in addition to the constant settings to the upper limit value/lower limit value.
- For details on smart object settings, see “2-2 Main Configurariion Items for Smart Objects” (page 2-5).

! Handling Precautions

- Be sure to enter a multiple of 16 when entering the bit device to lamp devices.
- Enter the bit device on the PLC for the Hide device. Do not enter word devices such as registers.
- When a registered graphic is used for the lamp graphic, the OFF graphic and ON graphic to be displayed must be created at the same size.
- When a registered graphic is used for the lamp graphic, the smart object size becomes the size of the graphic, and the smart object cannot be scaled.

Smart object name	Word type 3-state lamp				
Type	Lamps				
Scaling					Paste coordinates
Enlarge	Reduce	Reshape	Scaling factor	Text size	
○	○	○	Any	Fixed	Any

■ **Function**

- This smart object selects and displays the three states of lamp graphics according to the data range of the lamp device on the PLC.
- The following table shows the range settings as the display selection conditions of the three states.

State	Range setting
State 1	Lower limit value > Lamp device data
State 2	Upper limit value ≥ Lamp device data ≥ Lower limit value
State 3	Lamp device data > Upper limit value

■ **Configuration**

● **Basic**



- [Type]
This item is used for selecting the lamp type.
- [State]
This item is used for selecting the operation function of the lamp smart object.
- [Lamp device]
This item is for entering the word device to be monitored for switching graphic or text display.

● **Graphic**

Set the display graphics of state 1/2/3 to be displayed on the smart object and the display color of the graphics.

● **Text**

Set the display strings of state 1/2/3 to be displayed on the smart object and the display color of the strings.

● Range

Set the data range of state 1/2/3 display for the lamp device.

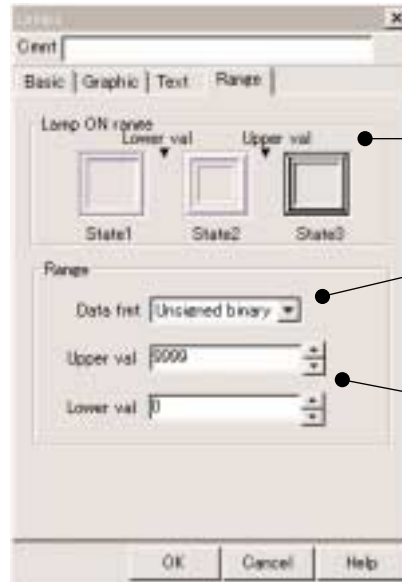

[Lamp ON range]
This item displays the display selected state of state 1/2/3.

[Data format]
This item is for selecting the data format of the value currently stored to the lamp device.

[Upper/lower value]
This item is for entering the upper/lower limit value of the lamp ON range.

• Range

Set the data type of the lamp device and the display selection range (upper/lower limit values) of the state.

■ Example

Lamp device = D100, upper limit value = 1000, lower limit value = 500

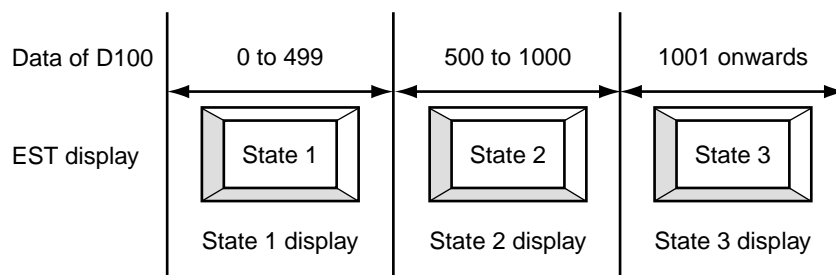

■ Smart Object Parameters

Tab name	Parameter name	Selection/setting item	Remarks
Basic	Lamp device	Enter the communications channel, the device address, and the word device.	
Graphic	Graphic type	Select the graphic type according to general/piping lamp/user.	
	OFF Graphic	Select the display graphic when the lamp is OFF.	
	Color when OFF	Select the display color of the graphic when the lamp is OFF.	
	Blink when OFF	Select to cause blinking when the lamp is OFF.	
	ON Graphic	Select the display graphic when the lamp is ON.	
	Color when ON	Select the display color of the graphic when the lamp is ON.	
Text	Blink when ON	Select to cause blinking when the lamp is ON.	
	Font size	Select the font size from 8 and 16 dots.	
	V alignment	Select vertical alignment from top/center/bottom.	
	H alignment	Select horizontal alignment from left/center/right.	
	Horizontal scale	Enter the horizontal scale of the string.	1 to 8
	Vertical scale	Enter the vertical scale of the string.	1 to 8
	OFF string	Enter the display text when the lamp is OFF.	
	Color when OFF	Enter the display text color when the lamp is OFF.	
	Blink when OFF	Select to cause blinking when the lamp is OFF.	
	ON string	Select the display text when the lamp is ON.	
Range	Color when ON	Select the display text color when the lamp is ON.	
	Blink when ON	Select to cause blinking when the lamp is ON.	
	Data format	Select the data format of the lamp device data from unsigned binary/signed binary/Hex/BCD.	
	Upper value	Enter the upper limit value of the lamp ON range.	
	Lower value	Enter the lower limit value of the lamp ON range.	

■ Supplementary Explanation

- Blinking of graphics is performed alternately between displaying of the state 1 graphic and displaying of the state 2/3 graphic.
- Blinking of text is performed alternately between displaying of the state 1 text and displaying of the state 2/3 text. The string currently set to state 2/3 is displayed as the text to be displayed.
- PLC devices can also be set in addition to the constant settings to the upper limit value/lower limit value.
- For details on smart object settings, see “2-2 Main Configuration Items for Smart Objects” (page 2-5).

! Handling Precautions

- Be sure to enter a multiple of 16 when entering the bit device to lamp devices.
- When a registered graphic is used for the lamp graphic, all state 1/2/3 graphics must be created at the same size.
- When a registered graphic is used for the lamp graphic, the smart object size becomes the size of the graphic, and the smart object cannot be scaled.

Smart object name	Word type multi-value state lamp				
Type	Lamps				
Scaling					Paste coordinates
Enlarge	Reduce	Reshape	Scaling factor	Text size	
○	○	○	—	—	Any

■ **Function**

- This smart object displays the value obtained by adding the offset data to the data of the lamp device on the PLC, and displays the graphic of the same registered graphic No.
- This lamp display smart object is exclusively for registered graphics.

■ **Configuration**

● **Basic**

The screenshot shows the 'Lamps' configuration dialog box. It has several fields and options:

- [Type]:** A dropdown menu currently set to 'IF Word'.
- [State]:** Radio buttons for '2-state', 'Settable', and 'Full'.
- [Lamp device]:** A text input field.
- [Hide device]:** A text input field with a checked checkbox.
- [Offset]:** A text input field.

 Callouts point to these fields with the following descriptions:

- [Type]:** This item is used for selecting the lamp type.
- [State]:** This item is used for selecting the operation function of the lamp smart object.
- [Lamp device]:** This item is for entering the word device to be monitored for switching graphic or text display.
- [Hide device]:** This item is for entering the bit device for clearing the graphic or text display.
- [Offset]:** This item is for entering the offset data to be added to the lamp device.

■ **Example**

Lamp device = D100, offset = 10

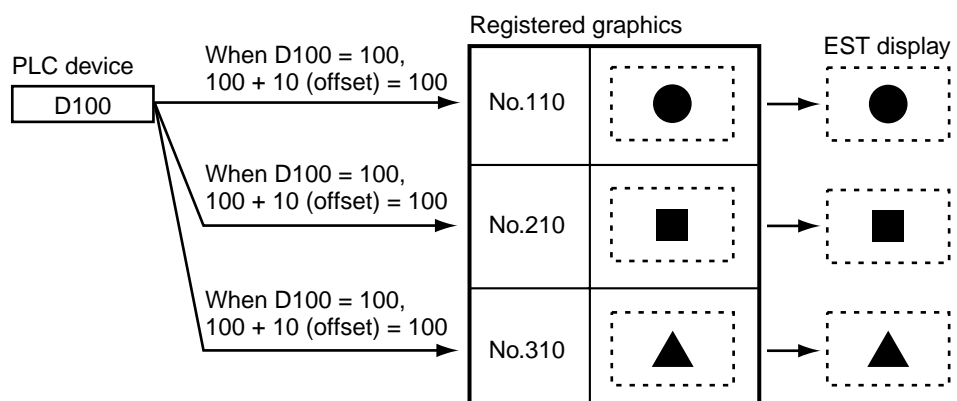

■ Smart Object Parameters

Tab name	Parameter name	Selection/setting item	Remarks
Basic	Lamp device	Enter the communications channel, the device address, and the word device.	
	Hide device	Enter the communications channel, the device address, and the bit device.	
	Offset	Enter the value to be added to the lamp device data.	-32768 to +32767

■ Supplementary Explanation

- Set the data of the lamp device in signed binary data format.
- The graphic display is not changed when the registered graphic No. to be displayed is not set.
- For details on smart object settings, see “2-2 Main Configuration Items for Smart Objects” (page 2-5).

! Handling Precautions

- Be sure to enter a multiple of 16 when entering the bit device to lamp devices.
- Enter the bit device on the PLC for the Hide device. Do not enter word devices such as registers.
- Create all graphics to be displayed at the same size.
- Scale and paste smart objects at the graphic size to be displayed.
If the size of the registered graphic to be displayed differs from the size of the paste smart object, the graphic may not be displayed at the correct size.



3 - 6 Numeric Indicators

Smart object name	Basic					
Type	Numeric indicators					
	Scaling				Paste coordinates	
	Enlarge	Reduce	Reshape	Scaling factor		Text size
	○	○		Integer multiple	Interlocked	Any

■ Function

- This smart object displays the data of numeric devices on the PLC.

[When alarm display is used]

- When the data of the numeric device exceeds the preset upper/lower limit value, the graphic and numeric value color to be displayed can be changed.

[When numeric keypad is used]

- When the numeric display is touched, the numeric keypad is called as a pop-up display. At this time, the startup source panel and other active panels are stopped.
- Data entered on the numeric keypad is written to the write device on the PLC.
- Completion of data writing can be notified to the PLC.
- When entry of data on the numeric keypad ends, the numeric keypad closes, and the state before the numeric keypad was called is returned to.
- The coordinates of the numeric keypad to call can be specified.

■ **Function**

● **Basic**

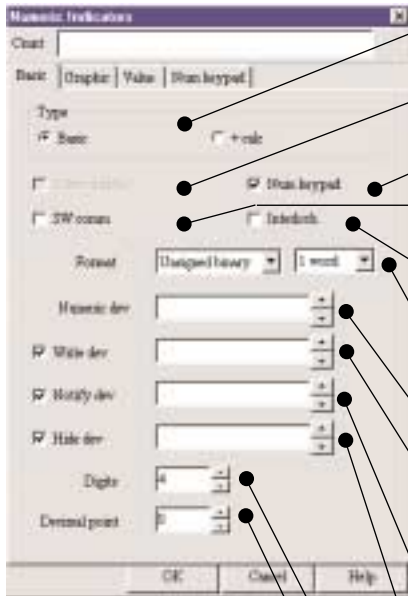

- [Type]
This item is for selecting the type of smart object for numeric display.
- [Alarm display]
This item enables display of numeric data alarms.
- [Numeric keypad]
This item calls the numeric keypad panel so that data can be set.
- [SW comm]
This item can be set when numeric keypad use has been selected. Select this item to use the switch communications functions.
- [Interlock]
This item can be set when numeric keypad use has been selected. Select this item to use the switch interlock functions.
- [Format]
This item is for selecting the data format of the numeric device.
- [Numeric device]
This item is for entering the word device on the PLC to be displayed.
- [Write device]
This item can be set when numeric keypad use has been selected. This item is for entering the word device when data entered on the numeric keypad is written to a device different from the numeric device.
- [Notify device]
This item can be set when numeric keypad use has been selected. This item is for entering the bit device to be set (turned ON) at completion of writing of the data entered on the numeric keypad.
- [Hide device]
This item is for entering the bit device for clearing the graphic or text display.
- [Digits]
This item is for entering the number of display digits.
- [Decimal point]
This item is for entering the decimal point position.

- **Alarm display**
When this checkbox is marked, the numeric display smart object has an alarm display function.
- **Numeric keypad**
When this checkbox is marked, the numeric display smart object has a numeric keypad call function.
When number keypad use is selected, the SW comm, interlock use, write device and notification device settings can be used.
- **Numeric device**
Enter the word device of the PLC on which data to be displayed is currently stored.
When numeric keypad use has been selected, the data entered on the numeric keypad is written to the word device of the PLC entered to the numeric device. Note, however, that when the write device has been set, the data entered on the numeric keypad will be written not to the numeric device but to the word device on the PLC entered to the write device.

- Write device

Enter the word device when data entered on the numeric keypad panel is to be written to a PLC device other than a numeric device.

- Notify device

Set the bit device to ON at completion of writing of the data entered on the numeric keypad.

The EST does not turn the notification device OFF. Turn the notification device OFF on the PLC after confirmation of the ON state of the bit.

- Graphic

- This sheet is for selecting the border graphic for numeric displays.
- When “Alarm display use” has been selected, sets the display graphic of the alarm state by ON graphic.
- When “Numeric keypad use” has been selected, sets the display graphic at numeric keypad call by ON graphic.

- Value

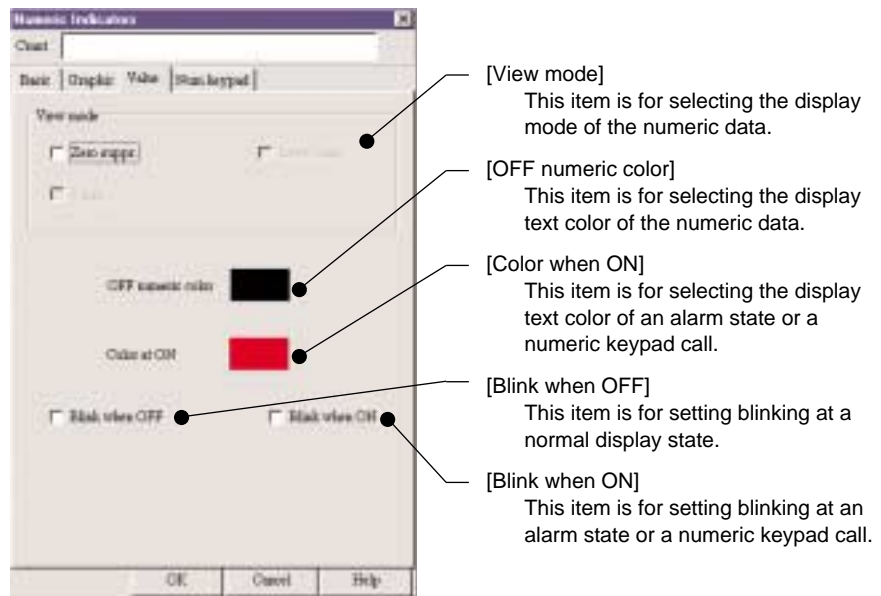

- View mode

Select the display mode of the numeric data.

- Zero suppress: Displays numeric data with zeros suppressed.
- + sign: Displays plus data prefixed with “+” when signed binary data is to be displayed.
- Lower case: Displays “A to F” in the lower case as “a to f” when displaying hexadecimal data.

● Alarm

This sheet is for setting the upper/lower limit values of the data when the alarm display is used.

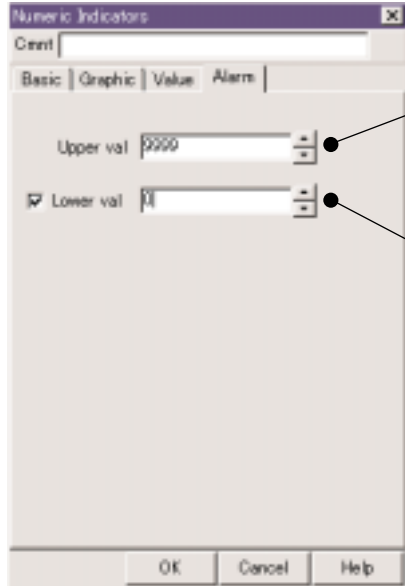

- [Upper value]
 - This item is for entering the upper limit value of the numeric data.
 - An alarm state occurs when the numeric data exceeds the upper limit value.
 - Alarm state: numeric data > upper limit value
- [Lower value]
 - This item is for entering the lower limit value of the numeric data.
 - An alarm state occurs when the numeric data falls below the lower limit value.
 - Alarm state: lower limit value > numeric data

● numeric keypad

This sheet is for setting the numeric keypad panel when the numeric keypad is used.

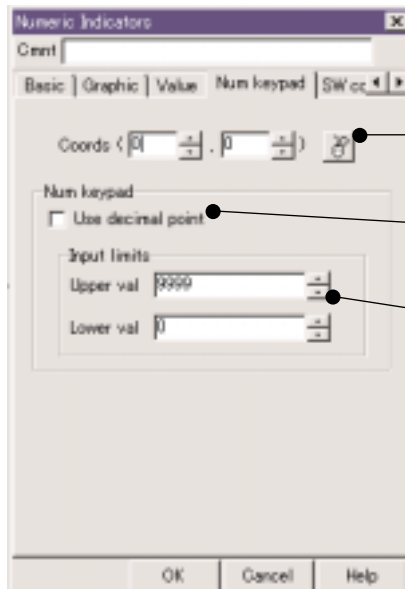

- [Coordinates]
 - This item is for entering the call coordinates of the numeric keypad panel.
- [Use decimal point]
 - Select this item when a numeric keypad panel with decimal point entry is to be used.
- [Upper/lower limits]
 - This item is for entering the data entry upper/lower limit values on the numeric keypad panel.

- Use decimal point
 - Call the numeric keypad panel having a decimal point entry function.
 - For details on the numeric keypad panel, see “5-2 Numeric Keypad” (page 5-4).
- Upper limit/Lower limit
 - Enter the valid range of the data when the data is set on the numeric keypad panel.
 - When the data entered on the numeric keypad panel exceeds the valid range when the [ENT] key is touched, an error occurs, a short, high-pitched alarm buzzers, and the set data is cleared to “0”.

[Data entry range]
 Upper limit value ≥ Setting data ≥ Lower limit value

● **Switch Communications**

This sheet is for setting the operation of switch communications functions.

● **Interlock**

This sheet is for setting the entry enabled conditions for the switch.

■ **Example**

Alarm display use, numeric device = D100, number of digits = 4, decimal point position = 1, alarm upper limit value = 1000, alarm lower limit value = 100

PLC data	Up to 99	100 to 1000	1001 on wards
EST display	ON display (alarm display)	OFF display (normal display)	ON display (alarm display)
D100	50	200	1050
Display	5.0	20.0	105.0

Numeric keypad use, numeric device = D100, number of digits = 4, decimal point position = 1, write device = D100, notification device = M000, numeric keypad entry upper limit value = 1500, numeric keypad entry lower limit value = 1000

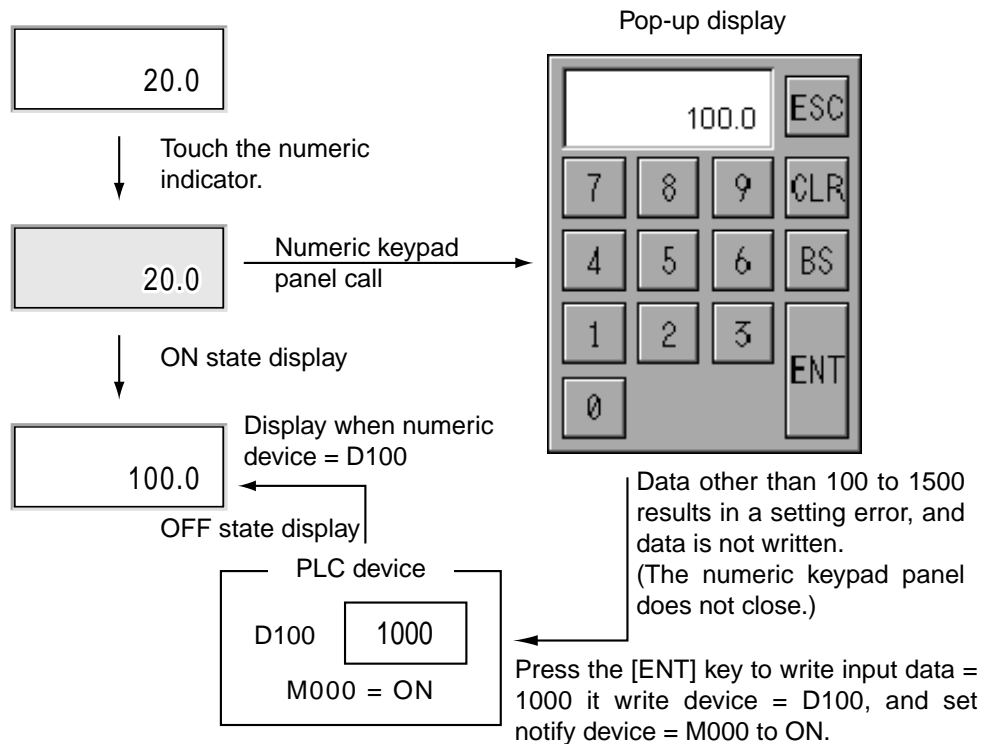

■ Smart Object Parameters

Tab name	Parameter name	Selection/setting item	Remarks
Basic	Alarm display	Select when using the alarm display function.	Cannot be selected when the numeric keypad is used.
	Numeric keypad	Select when using the numeric keypad call function.	Cannot be selected when the alarm display is used.
	Format	Select the data format of the numeric device from unsigned binary/signed binary/Hex/BCD.	
	Numeric device	Enter the communications channel, the station address, and the word device.	
	Write device	Enter the communications channel, the station address, and the word device.	Numeric keypad used
	Notify device	Enter the communications channel, the station address, and the bit device.	Numeric keypad used
	Hide device	Enter the communications channel, the station address, and the bit device.	
	Digits	Enter the number of display digits of the numeric data.	
	Decimal point	Enter the display position of the decimal point.	
	SW comm	Select when using switch communications.	Numeric keypad used
Interlock	Select when using interlocked operation.	Numeric keypad used	
Graphic	Type	Select the graphic type from general/user.	
	OFF Graphic	Select the display graphic at OFF.	
	Color when OFF	Select the display color of the OFF graphic.	
	Blink when OFF	Select to cause blinking when OFF.	When the numeric keypad or alarm display is used
	ON Graphic	Select the display ON graphic.	
	Color when ON	Select the graphic display color when ON.	
Blink when ON	Select to cause blinking when ON.		
Value	View mode	Select the view mode of the numeric value from zero suppress/+sign display/lower-case display.	
	OFF numeric color	Select the numeric display color when OFF.	When the numeric keypad or alarm display is used
	Blink when OFF	Select to cause blinking when OFF.	
	ON numeric color	Select the numeric display color when ON.	
	Blink when ON	Select to cause blinking when ON.	
Alarm	Upper value	Enter the constant or the communications channel, the station address, and the word device.	
	Lower value	Enter the constant or the communications channel, the station address, and the word device.	
Numeric keypad	Coordinates	Enter the call coordinates of the numeric keypad panel.	
	Use decimal point	Select the numeric keypad panel with decimal point entry.	
	Input upper value	Enter the upper limit value of the input data on the numeric keypad.	
	Input lower value	Enter the lower limit value of the input data on the numeric keypad.	
Switch communications	Switch code	Enter the switch code.	-32768 to +32767
	Switch communications function	Select the switch communications function.	
Interlock	Bit state judgment	Interlock action according to ON/OFF state of bit device	
	Range judgment	Interlock action according to bit device range	

■ Supplementary Explanation

- When 2-word data is to be displayed, the relationship between PLC devices and display is as follows.

[Example] Numeric device = D100, data format = Hex, 2 words, number of digits = 8

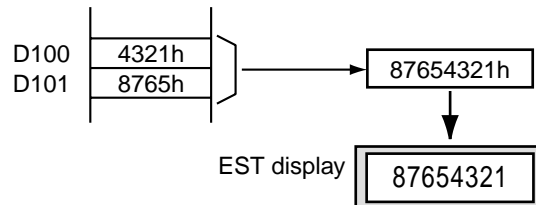

- The alarm display and numeric keypad call functions cannot be used simultaneously.
- For details on smart object settings, see “2-2 Main Configuration Items for Smart Objects” (page 2-5).
- For details on the numeric keypad panel, see “5-2 Numeric Keypad” (page 5-4).

! Handling Precautions

- Be sure to enter a multiple of 16 when entering the bit device to the numeric/write device.
- When displaying 2-word data, do not enter the final address of the PLC as the numeric/write device.
- Enter the bit device on the PLC for Clear/Notify devices. Do not enter word devices such as registers.
- Numeric keypad panels cannot be started up when a started up pop-up panel is currently active.
- When “User” has been selected at Graphic type, numeric values cannot be displayed correctly if the graphic size is smaller than the display data size (vertical: 16 dots, horizontal: 8 dots x number of digits).
- When zero suppress is selected, the zero suppress display is not active if the upper digit of the number of display digits is not “0”.

[Example] Numeric device = D100, data format = Hex, 2 words, number of digits = 4, zero suppress display

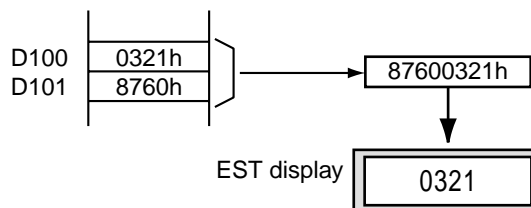

Smart object name	With calculation					
Type	Numeric indicator					
	Scaling				Paste coordinates	
	Enlarge	Reduce	Reshape	Scaling factor		Text size
	○	○		Integer multiple	Interlocked	Any

■ Function

- This smart object executes calculation processing on the numeric device on the PLC and displays the data resulting from that calculation.

[When alarm display is used]

- When the data of the calculation result exceeds the preset upper/lower limit value, the display graphic and numeric value color to be displayed can be changed.

[When numeric keypad is used]

- When the numeric display is touched, the numeric keypad is called as a pop-up display. At this time, the startup source panel and other active panels are closed.
- Data entered on the numeric keypad is written to the write device on the PLC.
- Calculation processing is executed on the value entered on the numeric keypad panel, and the result of that calculation is written to the write device.
- Completion of data writing can be notified to the PLC.
- When entry of data on the numeric keypad ends, the numeric keypad closes, and the state before the numeric keypad was called is returned to.
- The coordinates of the numeric keypad to call can be specified.

■ Function

● Basic

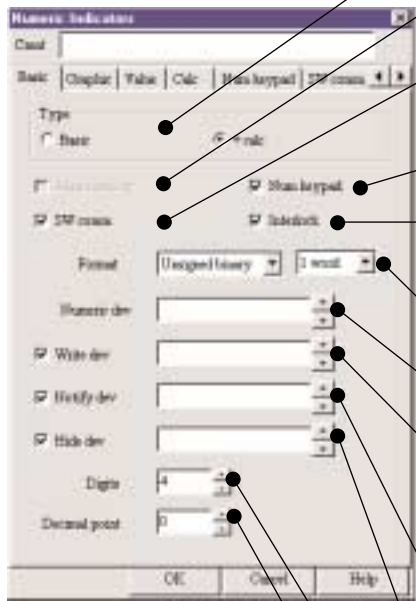

The screenshot shows the 'Numeric Indicators' dialog box with the following settings and callouts:

- [Type]**: This item is for selecting the type of smart object for numeric display.
- [Alarm display]**: This item enables display of numeric data alarms.
- [SW comm]**: This item can be set when numeric keypad use has been selected. Select this item to use the switch communications functions.
- [Numeric keypad]**: This item calls the numeric keypad panel so that data can be set.
- [Interlock]**: This item can be set when numeric keypad use has been selected. Select this item to use the switch interlock functions.
- [Format]**: This item is for selecting the data format of the numeric device.
- [Numeric device]**: This item is for entering the word device on the PLC to be displayed.
- [Write device]**: This item can be set when numeric keypad use has been selected. This item is for entering the word device when data entered on the numeric keypad is written to a device different from the numeric device.
- [Notify device]**: This item can be set when numeric keypad use has been selected. This item is for entering the bit device to be set (turned ON) at completion of writing of the data entered on the numeric keypad.
- [Hide device]**: This item is for entering the bit device for clearing the graphic or text display.
- [Number of digits]**: This item is for entering the number of display digits.
- [Decimal position]**: This item is for entering the decimal point position.

- **Alarm display**
When this checkbox is marked, the numeric display smart object has an alarm display function.
- **Numeric keypad**
When this checkbox is marked, the numeric display smart object has a numeric keypad call function.
When numeric keypad use is selected, the SW comm, interlock use, write device and notification device settings can be used.

- **Numeric device**

Enter the word device of the PLC on which data to be displayed is currently stored.

When numeric keypad use has been selected, the data entered on the numeric keypad is written to the word device of the PLC entered to the numeric device. Calculation processing preset at Write calculation data on the Calculation tab is executed on the value entered on the numeric keypad panel, and the result of that calculation is written to the numeric device.

[Example] Numeric keypad entry data = 100, write calculation mode = Add, calculation device = 110

100 + 10 is written to the numeric device.

Note, however, that when the write device has been set, the data entered on the numeric keypad will be written not to the numeric device but to the word device on the PLC entered to the write device.

- **Write device**

Enter the word device when data entered on the numeric keypad panel is to be written to a PLC device other than a numeric device.

- **Notify device**

Set the bit device to ON at completion of writing of the data entered on the numeric keypad.

The EST does not turn the notification device OFF. Turn the notification device OFF on the PLC after confirmation of the ON state of the bit.

- **Graphic**

- This sheet is for selecting the border graphic for numeric displays.
- When “Alarm display” has been selected, sets the display graphic of the alarm state by graphic at ON.
- When “Numeric keypad” has been selected, sets the display graphic at numeric keypad call by graphic at ON.

● Value

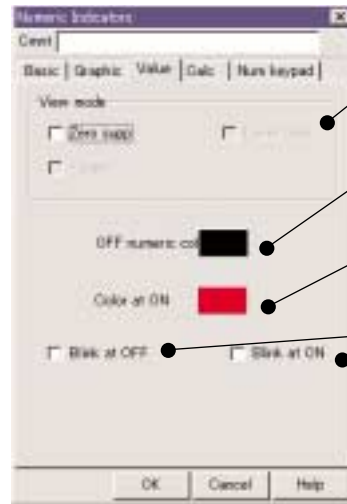

[View mode]

This item is for selecting the display mode of the numeric data.

[OFF numeric color]

This item is for selecting the display text color of the numeric data.

[Color when ON]

This item is for selecting the display text color of an alarm state or a numeric keypad call.

[Blink when OFF]

This item is for setting blinking at a normal display state.

[Blink when ON]

This item is for setting blinking at an alarm state or a numeric keypad call.

• View mode

Select the display mode of the numeric data.

Zero suppress: Displays numeric data with zeros suppressed.

+ sign: Displays plus data prefixed with “+” when signed binary data is to be displayed.

Lower case: Displays “A to F” in the lower case as “a to f” when displaying hexadecimal data.

● Calculation

This sheet is for setting the calculation method of the numeric data.

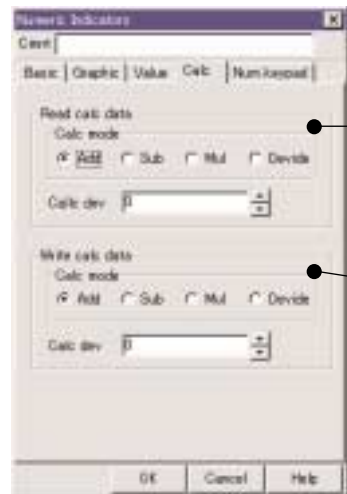

[Read calculation data]

Calculation processing preset at Read calculation data is performed on the numeric device, and the result of that calculation is displayed on the smart object.

[Write calculation data]

Calculation processing preset at Write calculation data is performed on the data entered on the numeric keypad panel, and the result of that calculation is written to the write device.

• Read calculation data

Calculates data read from the numeric device and the setting values of the calculation device for the read calculation data.

The data to be displayed on the smart object is the data after calculation processing.

• Write calculation data

This setting is enabled when the numeric keypad is used.

Calculates the data entered on the numeric keypad panel and the setting values of the calculation device for the write calculation data. The data after calculation processing is written to the PLC.

● Alarm

This sheet is for setting the upper/lower limit values of the data when the alarm display is used.

The numeric data to be verified by alarm display processing is the calculation result data obtained by performing calculation processing of the read calculation data on the numeric device.

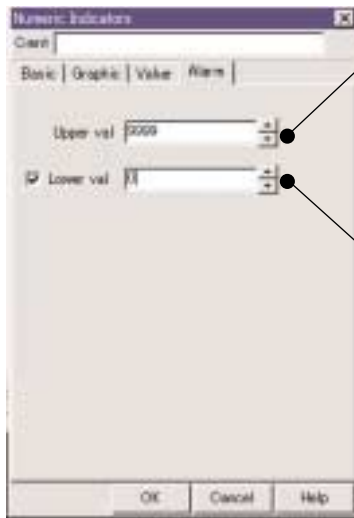

[Upper value]
This item is for entering the upper limit value of the numeric data.
An alarm state occurs when the numeric data exceeds the upper limit value.

Alarm state: numeric data > upper limit value

[Lower value]
This item is for entering the lower limit value of the numeric data.
An alarm state occurs when the numeric data falls below the lower limit value.

Alarm state: lower limit value > numeric data

● Numeric keypad

This sheet is for setting the numeric keypad panel when the numeric keypad is used.

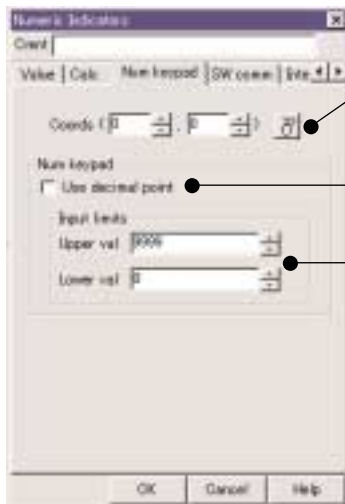

[Coordinates]
This item is for entering the call coordinates of the numeric keypad panel.

[Use decimal point]
Select this item when a numeric keypad panel with decimal point entry is to be used.

[Upper/lower value]
This item is for entering the data entry upper/lower limit values on the numeric keypad panel.

- Use decimal point
Call the numeric keypad panel having a decimal point entry function.
For details on the numeric keypad panel, see “5-2 Numeric Keypad” (page 5-4).
- Upper value/Lower value
Enter the valid range of the data when the data is set on the numeric keypad panel.
When the data entered on the numeric keypad panel exceeds the valid range when the [ENT] key is touched, an error occurs, a short, high-pitched alarm buzzers, and the set data is cleared to “0”.

[Data entry range]
Upper limit value ≥ Setting data ≥ Lower limit value

● **Switch Communications**

This sheet is for setting the operation of switch communications functions.

● **Interlock**

This sheet is for setting the entry enabled conditions for the switch.

■ **Example**

Alarm display use, numeric device = D100, number of digits = 4, decimal point position = 1, calculation mode = add, calculation device = 100, alarm upper limit value = 1000, alarm lower limit value = 200

PLC data	Up to 199	200 to 1000	1001 on wards
EST display	ON display (alarm display)	OFF display (normal display)	ON display (alarm display)
D100	50	200	1050
Read calculation	20 + 100 = 120	150 + 100 = 350	950 + 100 = 1050
Display	12.0	35.0	105.0

Numeric keypad use, numeric device = D100, number of digits = 4, decimal point position = 1, read calculation mode = add, read calculation device = 100, write calculation mode = subtract, write calculation device = 100, notification device = M000, numeric keypad entry upper limit value = 1500, numeric keypad entry lower limit value = 100

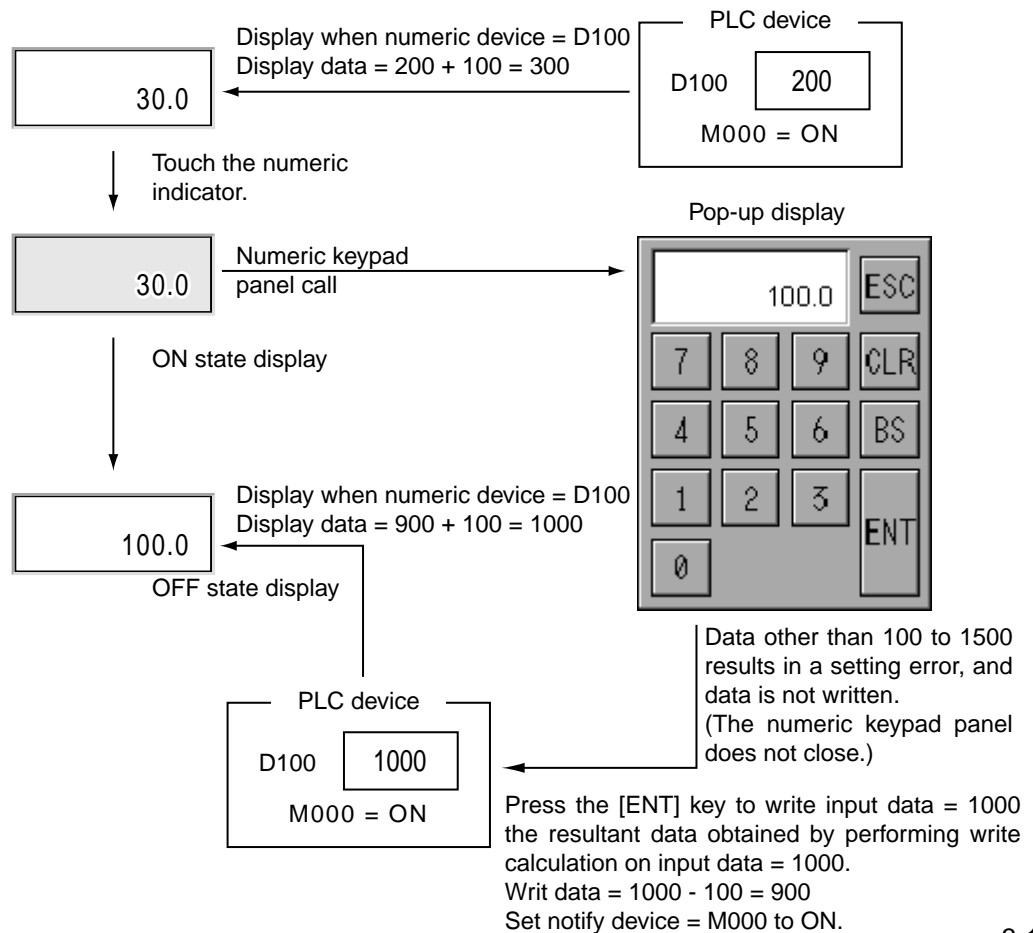

■ Smart Object Parameters

Tab name	Parameter name	Selection/setting item	Remarks
Basic	Alarm display	Select display function of alarm state.	Cannot be selected when the numeric keypad is used.
	Numeric keypad	Select the call function of the numeric keypad panel.	Cannot be selected when the alarm display is used.
	Format	Select the data format of the numeric device from unsigned binary/signed binary/Hex/BCD.	
	Numeric device	Enter the communications channel, the station address, and the word device.	
	Write device	Enter the communications channel, the station address, and the word device.	Numeric keypad used
	Notify device	Enter the communications channel, the station address, and the bit device.	Numeric keypad used
	Hide device	Enter the communications channel, the station address, and the bit device.	
	Digits	Enter the number of display digits of the numeric data.	
	Decimal point	Enter the display position of the decimal point.	
	SW comm	Select when using switch communications.	Numeric keypad used
	Interlock device	Select when using interlocked operation.	Numeric keypad used
Graphic	Type	Select the graphic type from general/user.	
	OFF Graphic	Select the display OFF Graphic.	
	Color when OFF	Select the display color of the OFF Graphic.	
	Blink when OFF	Select to cause blinking when OFF.	When the numeric keypad or alarm display is used
	ON Graphic	Select the display graphic when ON.	
	Color when ON	Select the graphic display color when ON.	
Blink when ON	Select to cause blinking when ON.		
Value	View mode	Select the display mode of the numeric value from zero suppress/+sign display/lower-case display.	
	OFF numeric color	Select the numeric display color when OFF.	
	Blink when OFF	Select to cause blinking when OFF.	When the numeric keypad or alarm display is used
	Color when ON	Select the numeric display color when ON.	
	Blink when ON	Select to cause blinking when ON.	
Calculation	Read calculation mode	Select the calculation mode for the display data from add/subtract/multiple/divide.	
	Read calculation device	Enter the constant or the communications channel, the station address, and the word device.	
	Write calculation mode	Select the calculation mode for the write data from add/subtract/multiple/divide.	
	Write calculation device	Enter the constant or the communications channel, the station address, and the word device.	
Alarm	Alarm upper limit value	Enter the constant or the communications channel, the station address, and the word device.	
	Alarm upper limit value	Enter the constant or the communications channel, the station address, and the word device.	
Numeric keypad	Coordinates	Enter the call coordinates of the numeric keypad panel.	
	Use decimal point	Select the numeric keypad panel with decimal point entry.	
	Input upper value	Enter the upper limit value of the input data on the numeric keypad.	
	Input lower value	Enter the lower limit value of the input data on the numeric keypad.	
Switch communications	Switch code	Enter the switch code.	-32768 to +32767
	Switch communications function	Select the switch communications function.	
Interlock	Bit state	Interlock action according to ON/OFF state of bit device	
	Range	Interlock action according to bit device range	

■ Supplementary Explanation

- When 2-word data is to be displayed, the relationship between PLC devices and display is as follows.

[Example] Numeric device = D100, data format = Hex, 2 words, number of digits = 8

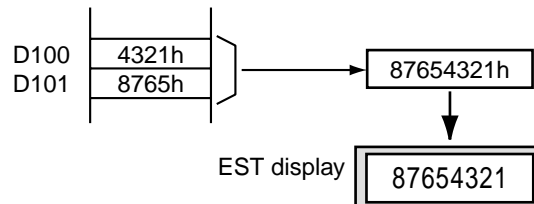

- Alarm display and numeric keypad functions cannot be used simultaneously.
- Set write calculation data only when numeric keypad use is selected.
- For details on smart object settings, see “2-2 Main Configuration Items for Smart Objects” (page 2-5).
- For details on the numeric keypad panel, see “5-2 Numeric Keypad” (page 5-4).

! Handling Precautions

- Be sure to enter a multiple of 16 when entering the bit device to the numeric/write device.
- When displaying 2-word data, do not enter the final address of the PLC as the numeric/write device.
- Enter the bit device on the PLC for Clear/Notify devices. Do not enter word devices such as registers.
- Numeric keypad panels cannot be started up when a started up pop-up panel is currently active.
- When “User” has been selected at Graphic type, numeric values cannot be displayed correctly if the graphic size is smaller than the display data size (vertical: 16 dots, horizontal: 8 dots x number of digits).
- When a calculation error (underflow/overflow) occurs in read calculation, “0” is displayed as the numeric data of the smart object.
- When a calculation error (underflow/overflow) occurs in write calculation, the data set on the numeric keypad is not written. (The notification device also is not set to ON.)

Note, however, that the numeric keypad panel closes.

- When zero suppress is selected, the zero suppress display is not active if the upper digit of the number of display digits is not “0”.

[Example] Numeric device = D100, data format = Hex, 2 words, number of digits = 4, zero suppress display

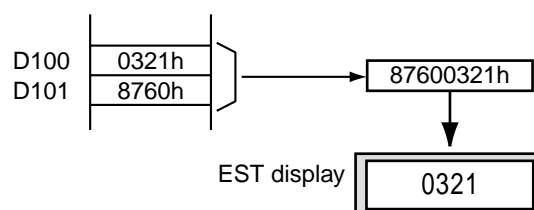

3 - 7 Graphs/Meters

Smart object name	Bar graph				
Type	Graphs/meters				
Scaling					Paste coordinates
Enlarge	Reduce	Reshape	Scaling factor	Text size	
○	○	○	Any	—	Any

■ Function

- These smart objects display the data of the numeric device on the PLC in the form of a bar graph.
- The display color of the bar can be changed when the data of the numeric device exceeds the upper/lower limit values preset on the alarm.
- The bar display can be cleared by setting the Hide device to ON.

■ Configuration

● Basic

[Type]
This item is for selecting the type of smart object for the graph/meter.

[Alarm display]
This item enables display of alarms on bar graphs.

[Display format]
This item is for selecting the display format of bar graphs.

[Data format]
This item is for selecting the data of numeric devices.

[Numeric device]
This item is for entering the word device on the PLC to be displayed as a bar graph.

[Hide device]
This item is for entering the bit device for clearing the graph display.

- **Display format**
Select the display format of the bar graphs.
 - Vertical: Displays bar graphs in the vertical direction.
 - Horizontal: Displays bar graphs in the horizontal direction.
 - Tank type: Displays bars as tank types in the vertical direction.
- **Data format**
Select the data of the numeric device from Signed binary/Unsigned binary/BCD. Note, however, that when tank type has been selected as the display format, the selection becomes Unsigned binary/BCD.

● Bar graph

This sheet is for setting the bar graph display.

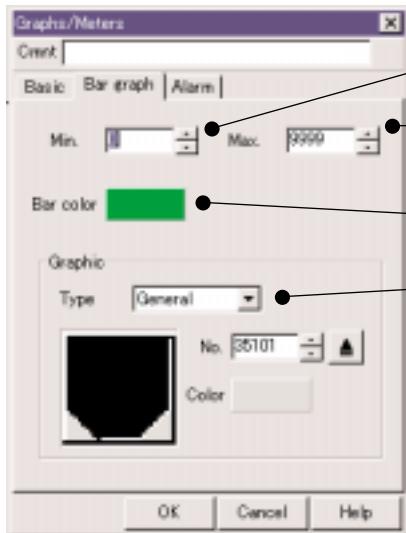

- [Minimum] This item is for entering the minimum value of the graph.
- [Maximum] This item is for entering the maximum value of the graph.
- [Bar color] This item is for selecting the display color of bar graphs.
- [No.] This item is for setting the tank graphic to be displayed when tank type has been selected at Display format. This item is not displayed in vertical/horizontal bar graph displays.

● Alarm

This sheet is for setting the alarm when the alarm display function is used.

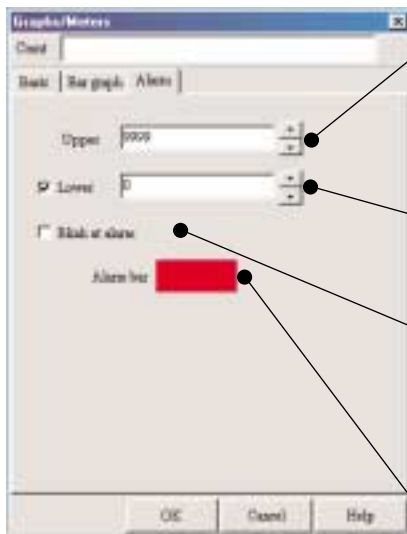

- [Upper] This item is for entering the upper limit value of the numeric data. An alarm state occurs when the numeric data exceeds the upper limit value.
Alarm state: numeric data > upper limit value
- [Lower] This item is for entering the lower limit value of the numeric data. An alarm state occurs when the numeric data falls below the lower limit value.
Alarm state: lower limit value > numeric data
- [Blink at alarm] When this item is selected, the bar graph is displayed blinking at the bar color and alarm bar color when an alarm occurs.
- [Alarm bar color] This item is for selecting the bar display color when an alarm occurs.

■ Example

Display format = vertical, numeric device = D000, maximum display value = 100, minimum display value = 0, alarm upper limit value = 70, alarm lower limit value = 30

Bar graph display

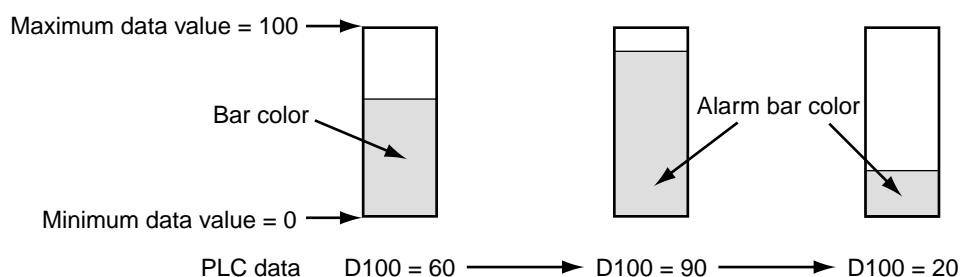

■ Smart Object Parameters

Tab name	Parameter name	Selection/setting item	Remarks
Basic	Display format	Select the display format of the bar graph from vertical/horizontal/tank type.	
	Data format	Select the data format of the numeric device from unsigned binary/signed binary/Hex/BCD.	
	Numeric device	Enter the communications channel, the device address, and the word device.	
	Hide device	Enter the communications channel, the device address, and the bit device.	
	Use alarm display	Select when the alarm display function is used.	
Bar graph	Minimum	Enter the minimum value of the display data.	
	Maximum	Enter the maximum value of the display data.	
	Bar color	Select the display color of the bar graph.	
	Type	Select general.	When tank type is selected
	No.	Select from the tank graphics.	When tank type is selected
	Color	Select the display color of the graphic.	When tank type is selected
Alarm	Upper	Enter the constant or the communications channel, the device address, and the word device.	
	Lower	Enter the constant or the communications channel, the device address, and the bit device.	
	Alarm bar color	Select the bar display color for when an alarm occurs.	
	Blink at alarm	Displays the bar display as blinking when an alarm occurs.	

■ Supplementary Explanation

- Signed binary data is displayed as a vertical (horizontal) bar with 0 as its origin.

Bar graph display

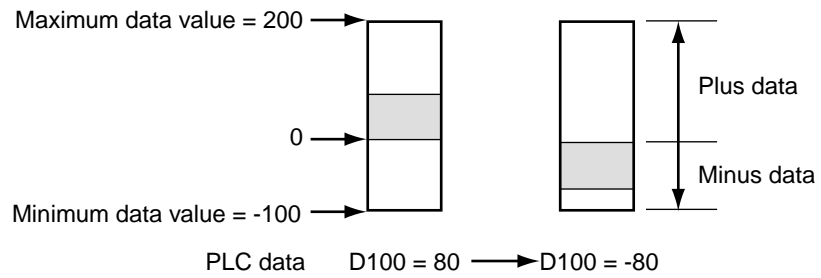

! Handling Precautions

- Enter the bit device on the PLC for the Hide device. Do not enter word devices such as registers.
- Be sure to enter a multiple of 16 when entering the bit device to the numeric device.
- The maximum display width of the bar graph is 255 dots. Bars of width 256 or more cannot be displayed.

Smart object name	Meter					
Type	Graphs/meters					
	Scaling				Paste coordinates	
	Enlarge	Reduce	Reshape	Scaling factor		Text size
	○	○		Any	—	Any

■ Function

- This smart object displays the data of the numeric device on the PLC in the form of a meter.

■ Configuration

● Basic

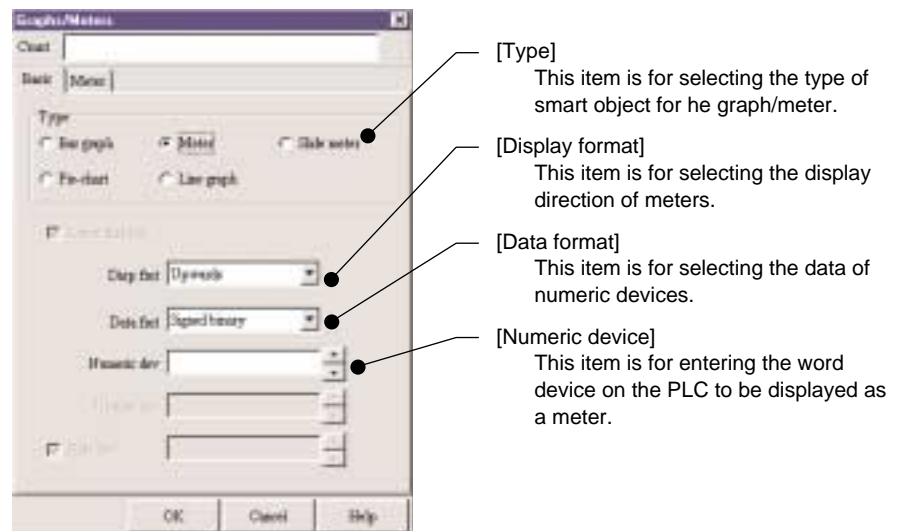

- **Display format**
Select the display direction of meters from Upwards/Downwards/Leftwards/Rightwards.
- **Data format**
Select the data of the numeric device from Signed binary/Unsigned binary/BCD.

● Meter

This sheet is for setting the meter display.

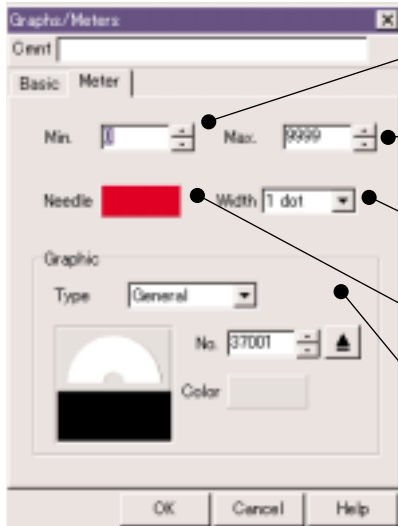

- [Minimum] This item is for entering the minimum value of the graph.
- [Maximum] This item is for entering the maximum value of the graph.
- [Width] This item is for selecting the thickness of the pointer displayed on the meter.
- [Needle] This item is for setting the color of the pointer displayed on the meter.
- [Graphic] This item is for selecting the graphic of the meter display.

■ Example

Numeric device = D000 = 70, minimum value = 0, maximum value = 100

[Upwards]

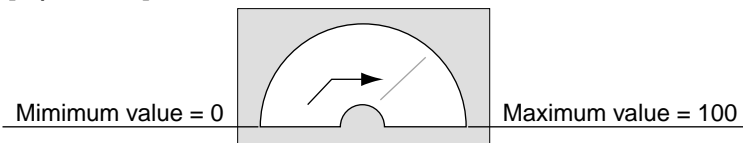

[Downwards]

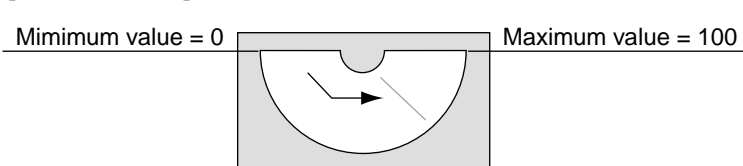

[Leftwards]

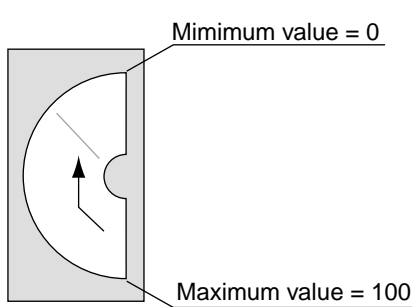

[Rightwards]

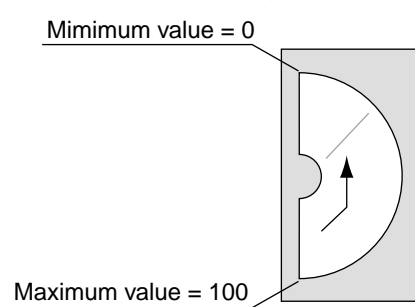

■ Smart Object Parameters

Tab name	Parameter name	Selection/setting item	Remarks
Basic	Display format	Select the meter display format from upwards/downwards/leftwards/rightwards.	
	Data format	Select the numeric data format from unsigned binary/signed binary/Hex/BCD.	
	Numeric device	Enter the communications channel, the device address, and the word device.	
Meter	Minimum value	Enter the minimum value of the display data.	
	Maximum value	Enter the maximum value of the display data.	
	Needle color	Select the display color of the needle.	
	Needle width	Select the needle width from 1 dot/3 dots/5 dots.	
	Type	Select the general graphic.	
	No.	Select the display graphic of the meter.	
	Color	Select the display color of the graphic.	

■ Supplementary Explanation

- When the display format is upwards/rightwards, the meter point moves in the clockwise direction.
- When the display format is downwards/leftwards, the meter point moves in the counterclockwise direction.

! Handling Precautions

- Be sure to enter a multiple of 16 when entering the bit device to the numeric device.

Smart object name	Slide meter					
Type	Graphs/meters					
	Scaling				Paste coordinates	
	Enlarge	Reduce	Reshape	Scaling factor		Text size
	○	○		Any	—	Any

■ **Function**

- This smart object displays the data of the numeric device on the PLC at the graphic display position.
- The graphic to be displayed can be changed when the data of the numeric device exceeds the preset upper/lower limit values.
- The graphic display can be cleared by setting the Hide device to ON.

■ **Configuration**

● **Basic**

The screenshot shows the 'Graphs/Meters' configuration dialog box. It includes a 'Chart' field, a 'Basic' tab with 'Alarm' sub-tab, and several configuration options. Callouts point to the following elements:

- [Type]**: Points to the 'Slide meter' radio button. Description: This item is for selecting the type of smart object for the graph/meter.
- [Alarm display]**: Points to the 'Alarm display' checkbox. Description: This item is for selecting the alarm display function.
- [Display format]**: Points to the 'Display format' dropdown menu. Description: This item is for selecting the display format of slide meters.
- [Data format]**: Points to the 'Data format' dropdown menu. Description: This item is for selecting the data of numeric devices.
- [Numeric device]**: Points to the 'Numeric dev' input field. Description: This item is for entering the word device of the PLC to be displayed as a slide meter.
- [Hide device]**: Points to the 'Hide dev' input field. Description: This item is for entering the bit device for clearing the display.

- **Display format**
Select the display format of the slide meter.
Vertical: Displays bar graphs in the vertical direction.
Horizontal: Displays bar graphs in the horizontal direction.
- **Data format**
Select the data of the numeric device from Signed binary/Unsigned binary/BCD.

● Slide meter

This sheet is for setting the slide meter display.

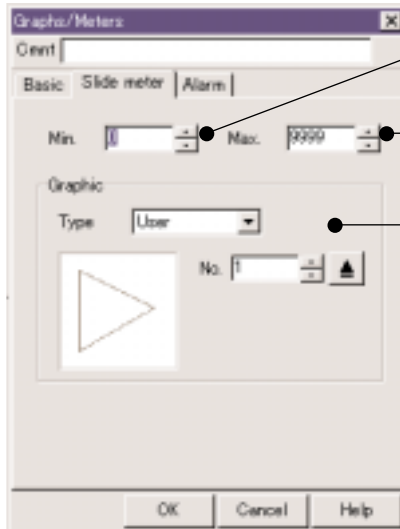

[Minimum]

This item is for entering the minimum value of the graph.

[Maximum]

This item is for entering the maximum value of the graph.

[Graphic]

This item is for selecting the graphic to be displayed on the slide meter.

• Graphic

Select the graphic from the graphics created as registered graphics. General graphics prepared in advance are not available.

A graphic is displayed as the slide meter with the data display point at the center of the graphic.

● Alarm

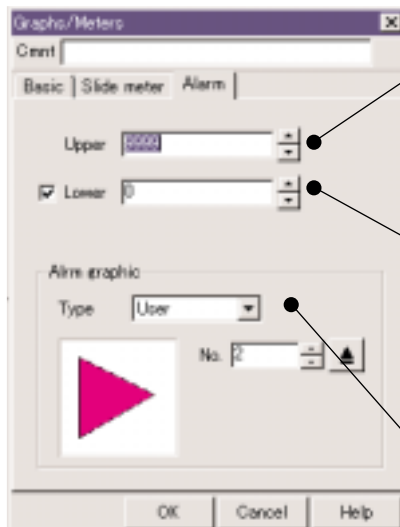

[Upper]

This item is for entering the upper limit value of the numeric data.

An alarm state occurs when the numeric data exceeds the upper limit value.

Alarm state: numeric data > upper limit value

[Lower]

This item is for entering the lower limit value of the numeric data.

An alarm state occurs when the numeric data falls below the lower limit value.

Alarm state: lower limit value > numeric data

[Alarm graphic]

This item is for selecting the display graphic when an alarm occurs.

■ Example

Display format = vertical, numeric device = D100, display maximum value = 100, display minimum value = 0, alarm upper limit value = 70, alarm lower limit value = 30

Slide meter display

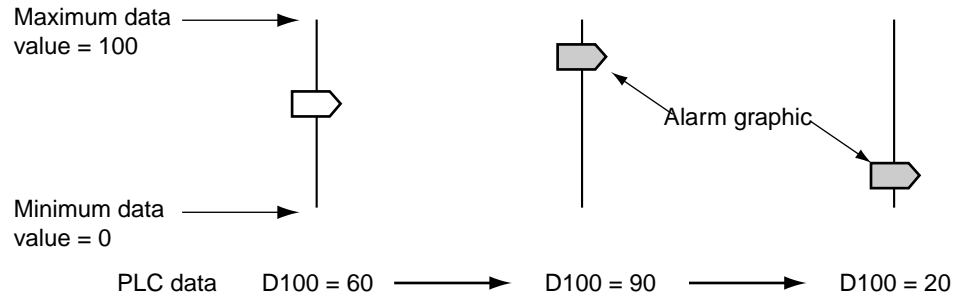

■ Smart Object Parameters

Tab name	Parameter name	Selection/setting item	Remarks
Basic	Display format	Select the display format of the slide meter from vertical/horizontal.	
	Data format	Select the data format of the numeric device from unsigned binary/signed binary/Hex/BCD.	
	Numeric device	Enter the communications channel, the station address, and the word device.	
	Hide device	Enter the communications channel, the station address, and the bit device.	
	Alarm display	Select when the alarm display function is used.	
Bar graph	Minimum value	Enter the minimum value of the display data.	
	Maximum value	Enter the maximum value of the display data.	
	Bar color	Select the display color of the bar graph.	
	Type	Select user.	
	No.	Select from the registered graphics.	1 to 999
Alarm	Upper	Enter the constant or the communications channel, the station address, and the word device.	
	Lower	Enter the constant or the communications channel, the station address, and the bit device.	
	Alarm graphic	Select the display graphic when an alarm occurs from the registered graphics.	1 to 999

! Handling Precautions

- The smart object frame displays the range in which the center of the graphic (user registered graphic) moves. When another display smart object overlaps the area of the registered graphic to the top, bottom, left or right of this center of movement, the smart object under the slide meter is no longer displayed.
- Enter the bit device on the PLC for the Hide device. Do not enter word devices such as registers.
- Be sure to enter a multiple of 16 when entering the bit device to the numeric device.
- Create registered graphics at a size of 64 x 64 dots or smaller. registered graphics may not be displayed properly if they are created at a larger size.

Smart object name	Pie-chart					
Type	Graphs/meters					
	Scaling				Paste coordinates	
	Enlarge	Reduce	Reshape	Scaling factor		Text size
	○	○		Any	—	Any

■ Function

- This smart object displays the data of the numeric device on the PLC in the form of a pie-chart.
- Data is displayed clockwise in the data order.

■ Configuration

● Basic

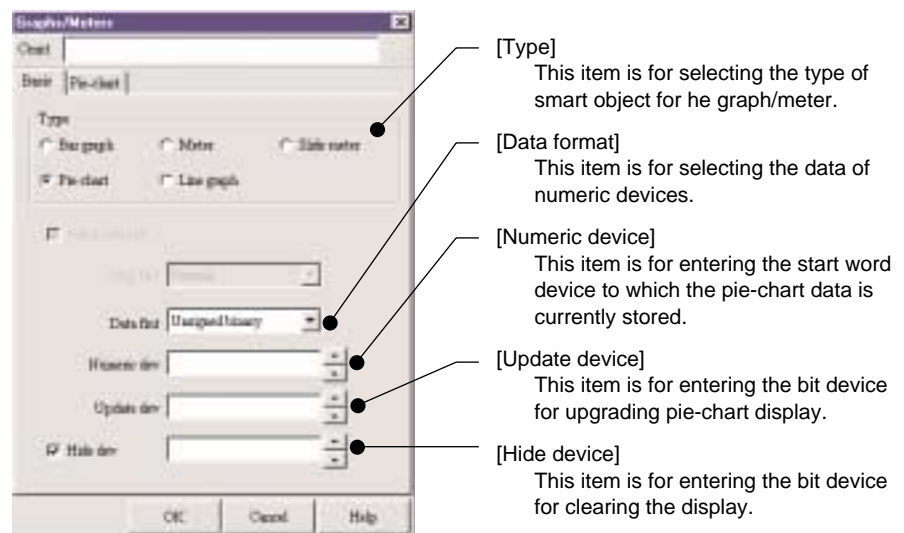

- **Data format**
Select the data of the numeric device from Unsigned binary/BCD.
- **Update device**
The pie-chart display is updated when the panel to which a smart object is pasted is started up and when the bit of the update device is set. If necessary, set the bit of the update device to ON.
The EST resets the update device to OFF when the display is updated.

● Pie-chart

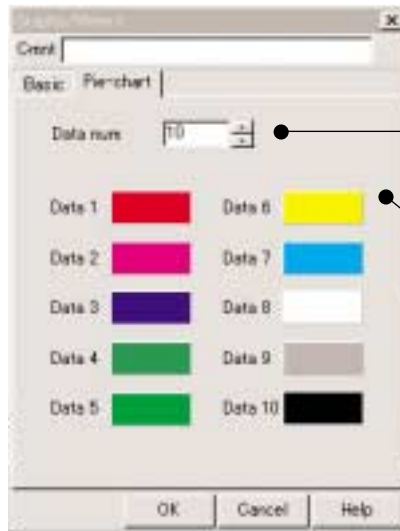

[Data number]
This item is for entering the number of data items to be displayed on the pie-chart.

[Display color]
This item is for selecting the display color of each data.

■ Example

Numeric device = D100, update device = M000, number of data items = 3

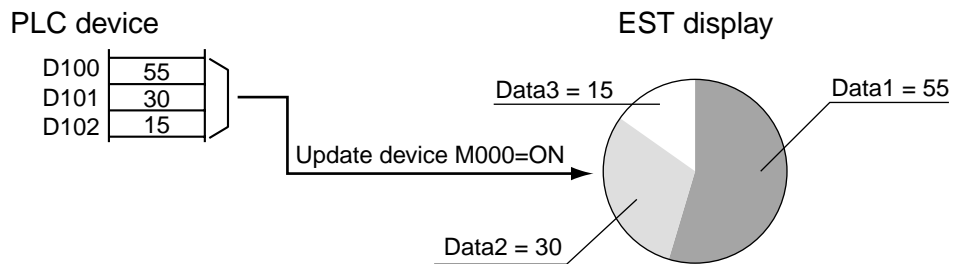

■ Smart Object Parameters

Tab name	Parameter name	Selection/setting item	Remarks
Basic	Data format	Select the numeric data format from unsigned binary/BCD.	
	Numeric device	Enter the communications channel, the device address, and the word device.	
	Update device	Enter the communications channel, the device address, and the bit device.	
	Hide device	Enter the communications channel, the device address, and the bit device.	
Pie-chart	Data number	Enter the number of data items to be displayed.	
	Data 1 to 10	Select the display color for data 1 to 10.	

■ Supplementary Explanation

- This smart object is transparent and has no graphic. Frames are also not displayed for the pie-chart. Draw frames if necessary.

! Handling Precautions

- Enter the word device on the PLC as the numeric device. Do not enter bit devices such as relays.
- Enter the bit device on the PLC as the Update/Hide device. Do not enter the word devices such as registers.

Smart object name	Line graph				
Type	Graphs/meters				
Scaling					Paste coordinates
Enlarge	Reduce	Reshape	Scaling factor	Text size	
<input type="radio"/>		<input type="radio"/>	Any	—	Any

■ Function

- This smart object displays the data of the numeric device on the PLC in the form of a line graph.
- Up to 128 points can be displayed.
- The minimum and maximum values can be set to the X and Y axis.

■ Configuration

● Basic

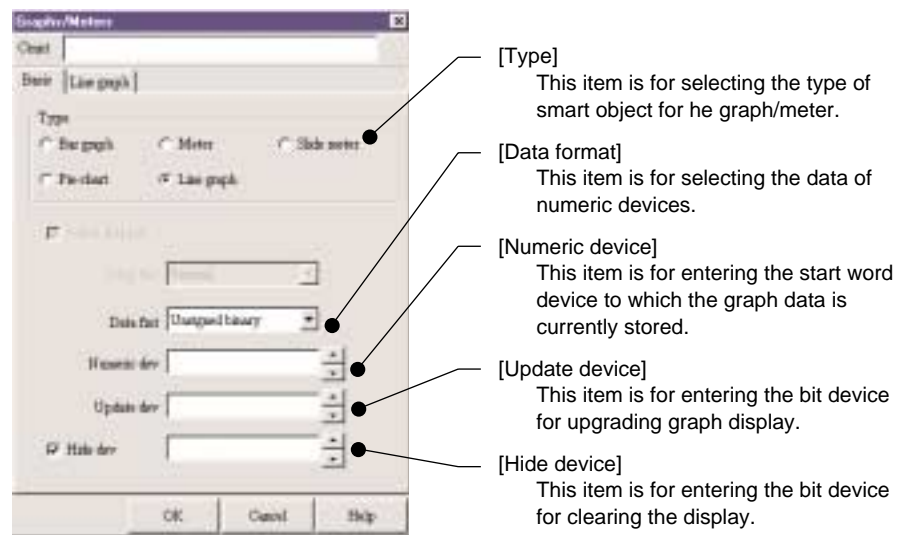

- **Data format**
Select the data of the numeric device from Unsigned binary/Signed binary/BCD.
- **Update device**
The pie-chart display is updated when the panel to which a smart object is pasted is started up and when the bit of the update device is set. If necessary, set the bit of the update device to ON.
The EST resets the update device to OFF when the display is updated.

● Line graph

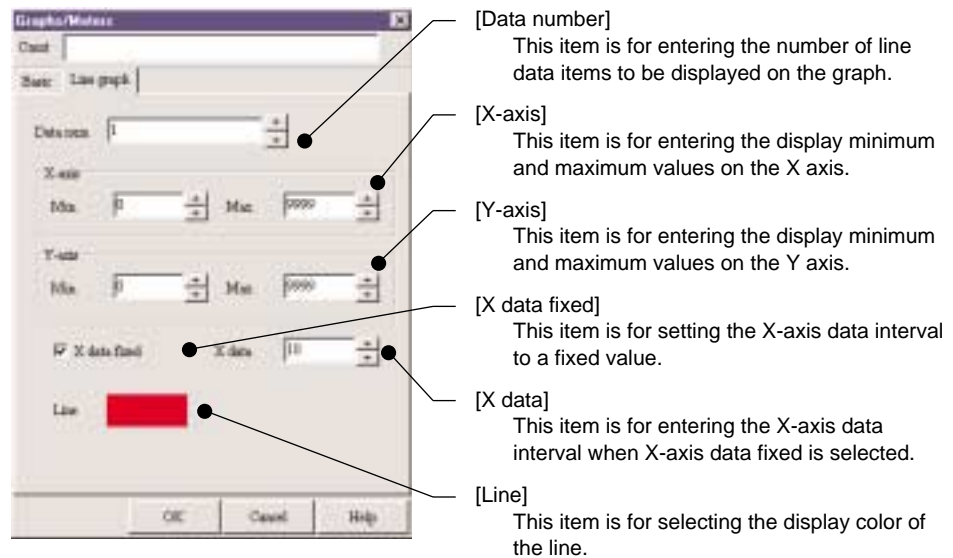

- **Data number**
 Enter the number of display points on the line graph. The maximum number of display points is 128.
 You can also enter the PLC device at this item to control the number of display data points on the PLC.
 In this case, enter binary data within the range 1 to 128 as the PLC data.

- **X data fixed**
 [Not fixed]
 Set the number of display points in order X-axis then Y-axis as the data of the line graph starting from the address of the numeric device.

Numeric device	X1 data
	X1 data
	X2 data
	Y2 data
	:
	:
	Xn data
	Yn data

n: Number of data items

- [Fixed]
 Set the number of display points for the Y-axis only as the data of the line graph starting from the address of the numeric device. Enter the X-axis display interval at X-axis data.

Numeric device	Y1 data
	Y1 data
	Y3 data
	:
	:
	Yn data

n: Number of data items

■ Example

- When X-axis data fixed is not selected
Numeric device = D100, update device = M000, number of data items = 5

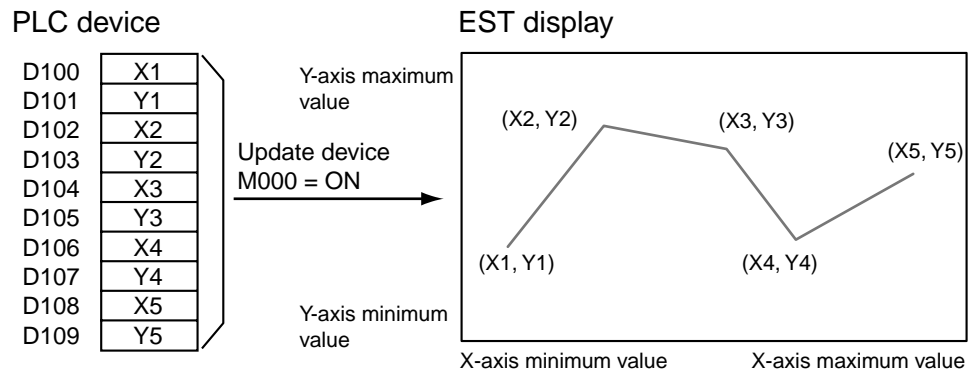

- When X-axis data fixed is selected
Numeric device = D100, update device = M000, number of data items = D099,
X-axis data = 10

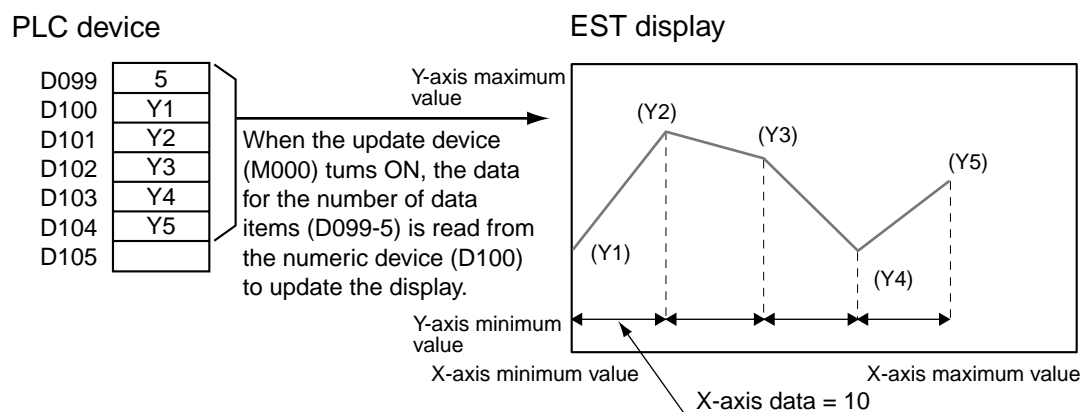

■ Smart Object Parameters

Tab name	Parameter name	Selection/setting item	Remarks
Basic	Data format	Select the numeric data format from unsigned binary/signed binary/BCD.	
	Numeric device	Enter the communications channel, the device address, and the word device.	
	Update device	Enter the communications channel, the device address, and the bit device.	
	Hide device	Enter the communications channel, the device address, and the bit device.	
Broken line	Data number	Enter the constant or the communications channel, the device address, and the word device.	1 to 128
	Minimum of X-axis	Enter the minimum value of X-axis.	
	Maximum of X-axis	Enter the maximum value of X-axis.	
	Minimum of Y-axis	Enter the minimum value of Y-axis.	
	Maximum of Y-axis	Enter the maximum value of Y-axis.	
	X data fixed	Set the display interval of the X-axis to a fixed value.	
	X data	Enter the display interval of the X-axis.	When X-axis data fixed is selected
Line	Select the display color of the broken line.		

■ Supplementary Explanation

- This smart object is transparent and has no graphic. Frames are also not displayed for the pie-chart. Draw frames if necessary.
- When X-axis data is not to be fixed, set the display coordinates as the X-axis data. When X-axis data has been selected to Fixed, the X-axis data is displayed at the data interval set at X-axis data.

❗ Handling Precautions

- Enter the word device on the PLC as the numeric device. Do not enter bit devices such as relays.
- Enter the bit device on the PLC as the Update/Hide device. Do not enter the word devices such as registers.
- When the PLC device has been set to the number of data items, set data of the same format as the data format as the data to be set.
When the data format is Unsigned binary/Signed binary, set binary data within the range 1 to 128.
When the data format is BCD, set BCD data within the range 1 to 128.

3 - 8 Text Display

Smart object name	Registered string data						
Type	Text display						
					Scaling		Paste coordinates
		Enlarge	Reduce	Reshape	Scaling factor	Text size	
		<input type="radio"/>	<input type="radio"/>	<input type="radio"/>	Any	Fixed	Any

■ Function

- This smart device displays the string of the same registered string No. as the value obtained by adding the offset value to the data of the string device on the PLC.

■ Configuration

● Basic

The screenshot shows the 'Text' configuration dialog box with the following callouts:

- [Type]**: This item is for selecting the type of string display smart object. (Points to the radio buttons for 'Reg. string data', 'Message coil', and 'Var. string data').
- [String device]**: This item is for entering the word device for switching the string display. (Points to the 'String dev' field containing 'NR0000').
- [Offset]**: This item is for entering the offset value to be added to the string device. (Points to the 'Offset' field containing '0').
- [Lamp device]**: This item is for entering the bit device to be monitored for switching graphic or text color display. (Points to the 'Lamp dev' field).
- [Hide device]**: This item is for entering the bit device for clearing the graphic or text display. (Points to the 'Clear dev' field).

● Graphic

Set the border graphic to be displayed on the smart object and the display color of the graphic.

When a lamp device is used, the graphic setting becomes OFF Graphic and ON Graphic.

● Text

The string setting is not available as the registered string specified by the string device is displayed. Set the text color to be displayed.

When a lamp device is used, the string setting becomes String at OFF and String at ON.

■ Example

String device = D100, offset = 10



■ Smart Object Parameters

Parameter type	Parameter name	Selection/setting item	Remarks
Basic	String device	Enter the communications channel, device address and word device.	
	Offset	Enter the value to be added to the data of the string device.	-32768 to +32767
	Lamp device	Enter the communications channel, the device address, and the bit device.	
	Hide device	Enter the communications channel, the device address, and the bit device.	When lamp devices are used
Graphic	Type	Select the graphic type from general/user.	
	OFF Graphic	Select the graphic displayed at OFF.	
	Color when OFF	Select the display color of the OFF graphic .	
	Blink when OFF	Select to cause blinking when OFF.	When lamp devices are used
	ON Graphic	Select the display graphic when the lamp is ON.	When lamp devices are used
	Color when ON	Select the display color of the graphic when the lamp is ON.	When lamp devices are used
Text	Blink when ON	Select to cause blinking when the lamp is ON.	When lamp devices are used
	Font size	Select the font size from 8 and 16 dots.	
	V alignment	Select vertical alignment from top/center/bottom.	
	H alignment	Select horizontal alignment from left/center/right.	
	Horizontal scale	Enter the horizontal scale of the string.	1 to 8
	Vertical scale	Enter the vertical scale of the string.	1 to 8
	OFF color	Enter the display text color when OFF.	
	Blink when OFF	Select to cause blinking at OFF.	When lamp devices are used
ON color	Select the display text color when the lamp is ON.	When lamp devices are used	
Blink when ON	Select to cause blinking when the lamp is ON.	When lamp devices are used	

■ Supplementary Explanation

- Set the data of the string device in signed binary data format.
- The string is not displayed when the string of the registered graphic No. to be displayed is not set.
- The Hide device can be set when a lamp device is used.
- For details on smart object settings, see “2-2 Main Configuration Items for Smart Objects” (page 2-5).

❗ Handling Precautions

- Be sure to enter a multiple of 16 when entering the bit device to the character string data device.
- Enter the word device on the PLC as the lamp/Hide device. Do not enter bit devices such as relays.
- When a registered graphic is used for the switch graphic, the OFF graphic and ON graphic to be displayed must be created at the same size.
- When a registered graphic is used for the switch graphic, the smart object size becomes the size of the graphic, and the smart object cannot be scaled.

Smart object name	Variable string data					
Type	Text display					
				Scaling		Paste coordinates
Enlarge		Reduce		Reshape	Scaling factor	
○		○		○	Any	Fixed
						Any

■ **Function**

- This smart object displays the string data of ASCII code currently set to device area on the PLC starting from the string device.

[When “Keyboard use” is selected]

- When the string display field is touched, this smart object calls up the keyboard panel, and closes the startup source panel and other active panels.
- On the keyboard panel, the data for the number of display characters can be written to the string device on the PLC.
- When entry of data on the keyboard panel ends, the keyboard panel closes, and the state before the keyboard panel was called is returned to.
- The coordinates of the keyboard panel to be called up can be specified.

■ **Configuration**

● **Basic**

The screenshot shows the 'Text Display' configuration window with the following settings and callouts:

- [Type]**: This item is for selecting the type of string display smart object. (Callout points to the 'Message out' radio button.)
- [Read conditions]**: This item is for selecting the read conditions of the string data. (Callout points to the 'Bit trigger' radio button.)
- [Keyboard use]**: This item calls up the keyboard panel so that strings can be set. (Callout points to the 'Keyboard use' checkbox.)
- [String device]**: This item is for inputting the word device on the PLC to which the string data is currently stored. (Callout points to the 'String dev' dropdown menu.)
- [Size]**: This item is for inputting the number of strings to be displayed by 2-byte conversion. (Callout points to the 'Size' numeric input field.)
- [Update device]**: This item is for inputting the bit device for updating the string display when External trigger is set to Read conditions. (Callout points to the 'Update dev' dropdown menu.)
- [Lamp device]**: This item is for entering the bit device to be monitored for switching graphic or text color display. (Callout points to the 'Lamp dev' dropdown menu.)
- [Hide device]**: This item is for entering the bit device for clearing the graphic or text display. (Callout points to the 'Hide dev' dropdown menu.)

- **Read conditions**

Select the conditions for reading the string data.

- Normal: String data is read from the PLC at each scan on the EST to update the display.
- At startup: String data is read from the PLC to update the display once when the panel is started up.
- External trigger: The string data is read from the PLC to update the display when the panel is started up and when the state of the update device changes to ON.

- **Keyboard use**

The smart object becomes a variable string smart object having a function for calling up the keyboard panel.

Lamp devices cannot be used at this time.

- **String device**

Enter the start address of the device area on the PLC to which the string data is currently stored.

The string data is displayed in byte units from the lower byte up to the upper byte after confirmation of the data.

- **Size**

Enter the number of characters currently stored to the string device area on the PLC by 2-byte conversion. Set “3” for six 1-byte characters and “2” for three characters.

The EST reads and displays the data for the number of characters set to Number of display characters from the string device.

(number of display characters = number of read words (2 bytes))

- **Graphic**

When a lamp device is used, the graphic setting becomes OFF Graphic and ON Graphic.

When “Keyboard use” is selected, set the display graphic when the keyboard is called up as ON graphic.

● **Text**

The string setting is not available as the string data currently stored to the string device on the PLC is displayed.
 Set the text color to be displayed.
 When a lamp device is used, the string setting becomes String at OFF and String at ON.
 When “Keyboard use” is selected, set the display text color when the keyboard is called up as the ON text color.

● **Keyboard**

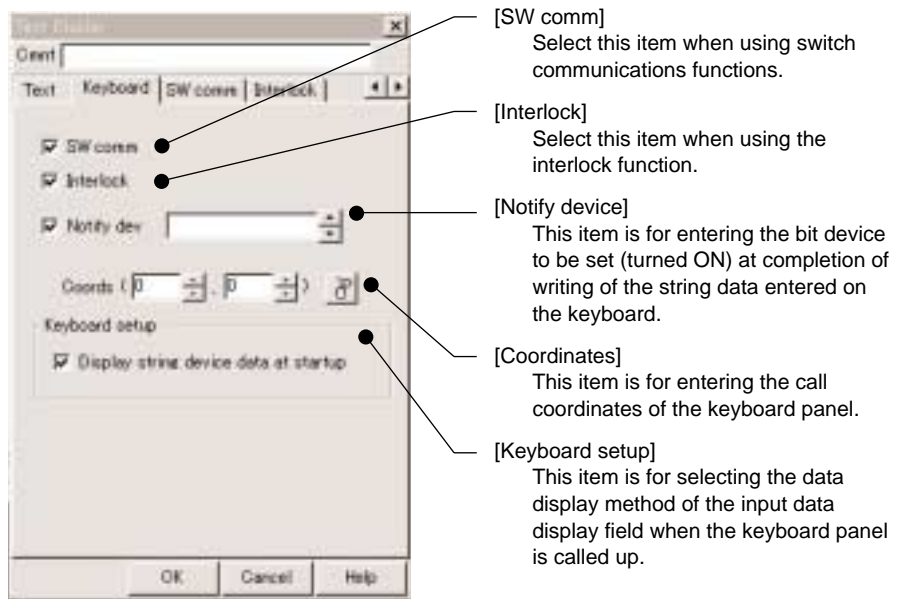

- **Notify device**
 The bit device is set to ON at completion of writing of string data entered on the keyboard panel. The EST does not set notifications devices to OFF. Set the notification device on the PLC after confirming the ON state of the bit.
- **Keyboard setup**
 When the “Display string device data at startup” checkbox is marked, the string data currently set to the string device is displayed at the input data display field when the keyboard panel is displayed.

● **Switch Communications**

Set the operation of switch communications functions.

● **Interlock**

Set the entry enabled conditions for the switch.

■ Example

- String device = D100, number of display characters = 6

PLC device

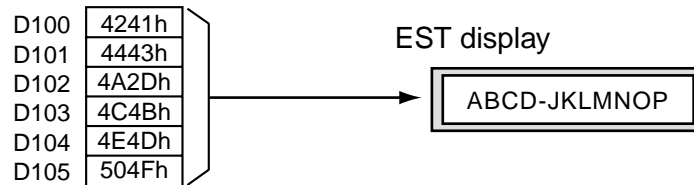

- Keyboard use, string device = D100, number of display characters = 8, notify device = M000

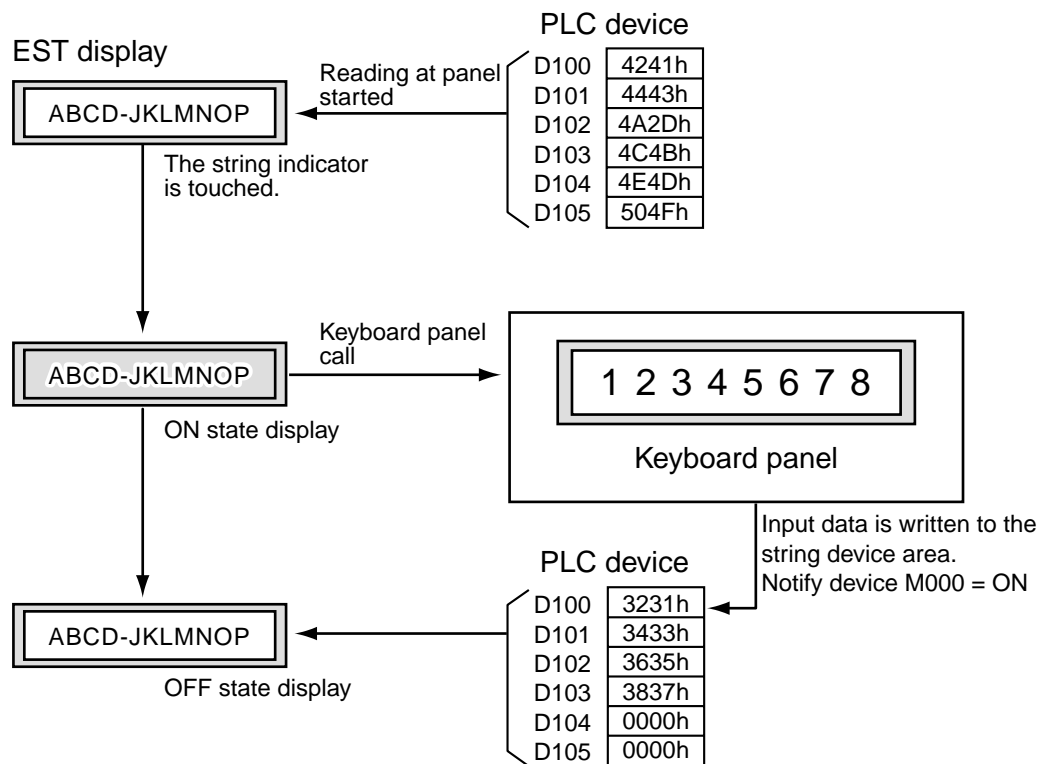

■ Smart Object Parameters

Tab name	Parameter name	Selection/setting item	Remarks
Basic	Read conditions	Select the read conditions of the string data from always/panel start/external trigger.	
	Keyboard use	Select when the keyboard panel call function is used.	
	String device	Enter the communications channel, the device address, and the word device.	
	Size	Enter the number of display characters.	1 to 64
	Update device	Enter the communications channel, the device address, and the bit device.	When read conditions and external trigger are selected
	Lamp device	Enter the communications channel, the device address, and the bit device.	
	Hide device	Enter the communications channel, the device address, and the bit device.	
Graphic	Type	Select the graphic type from general/user.	
	OFF Graphic	Select the graphic displayed at OFF.	
	Color when OFF	Select the display color of the OFF Graphic.	
	Blink when OFF	Select to cause blinking at OFF.	
	ON Graphic	Select the display ON graphic.	
	Color when ON	Select the graphic display color when ON.	
	Blink when ON	Select to cause blinking when ON.	
Text	Font size	Select the font size from 8 and 16 dots.	
	V alignment	Select vertical alignment from top/center/bottom.	
	H alignment	Select horizontal alignment from left/center/right.	
	Horizontal scale	Enter the horizontal scale of the string.	1 to 8
	Vertical scale	Enter the vertical scale of the string.	1 to 8
	OFF color	Enter the display text color when OFF.	
	Blink when OFF	Select to cause blinking at OFF.	
	ON color	Select the display text color when the lamp is ON.	
	Blink when ON	Select to cause blinking when the lamp is ON.	
Keyboard	Notify device	Enter the communications channel, the device address, and the bit device.	
	Coordinates	Enter the call coordinates of the keyboard panel.	
	Keyboard setup	Select the display setting when the keyboard panel is called up.	
	SW comm	Select when switch communications is used.	
Switch communications	Interlock	Select when using interlocked operation.	-32768 to +32767
	Switch code	Enter the switch code.	
	Switch communications	Select the switch communications function.	
Interlock	function		
	Bit state	Interlock action according to ON/OFF state of bit device	
	Range	Interlock action according to bit device range	

■ Supplementary Explanation

- Set the data of the string device in signed binary data format.
- The lamp device setting is not available when “Keyboard use” is selected. However, the Hide device can be set.
- For details on smart object settings, see “2-2 Main Configuration Items for Smart Objects” (page 2-5).
- For details on the keyboard panel, see “5-3 Keyboard” (page 5-8).

! Handling Precautions

- Enter the word device on the PLC as the String device. Do not enter bit devices such as relays.
- Enter the word device on the PLC as the lamp/Hide device. Do not enter bit devices such as relays.
- When a registered graphic is used for the switch graphic, the OFF graphic and ON graphic to be displayed must be created at the same size.
- When a registered graphic is used for the switch graphic, the smart object size becomes the size of the graphic, and the smart object cannot be scaled.
- The range of the string data is expressed as an ASCII code value.
- Text exceeding the smart object size is not displayed. Data is displayed for the maximum number of characters that can be displayed.
- When the smart object size is smaller than the text size to be displayed, strings are not displayed.
- When the string data on the PLC contains “00 Hex”, string data from 00 Hex onwards is not displayed.
- When the number of entered characters on the keyboard panel is less than the number of characters to be called from the PLC when “Keyboard use” is selected, “00 Hex” is written to areas to which strings are not entered.
“00 Hex” is not written when the number of characters entered on the keyboard panel is the same as the number of characters to be called from the PLC.

Smart object name	Message call					
Type	Text display					
				Scaling		Paste coordinates
Enlarge		Reduce		Reshape	Scaling factor	
○		○		○	Any	Fixed
						Any

■ **Function**

- This smart object calls up message panels, and closes the startup source panel and closes other active panels.
- The message panel displays the same registered string No. as the value specified on the string device.
- When the “Return” key is pressed on the called up message panel, the message panel closes, and the state before the message panel is called is returned to.
- The coordinates of the message panel to be called up can be specified.

■ **Configuration**

● **Basic**

The image shows a configuration dialog box for a 'Message call' smart object. It has several fields and checkboxes. Callouts point to the following items:

- [Type]:** Points to the 'Type' section where 'Message call' is selected.
- [String device]:** Points to the 'String dev' field.
- [Panel]:** Points to the 'Panel' field.
- [Lamp device]:** Points to the 'Lamp dev' field.
- [Hide device]:** Points to the 'Clear dev' field.

● **Graphic**

Set the switch graphic to be displayed on the smart object and the display color of the graphic.

When a lamp device is used, the graphic setting becomes OFF Graphic and ON Graphic.

● **Text**

Set the string to be displayed on the smart object and the display text color.

When a lamp device is used, the string setting becomes String when OFF and String when ON.

■ Example

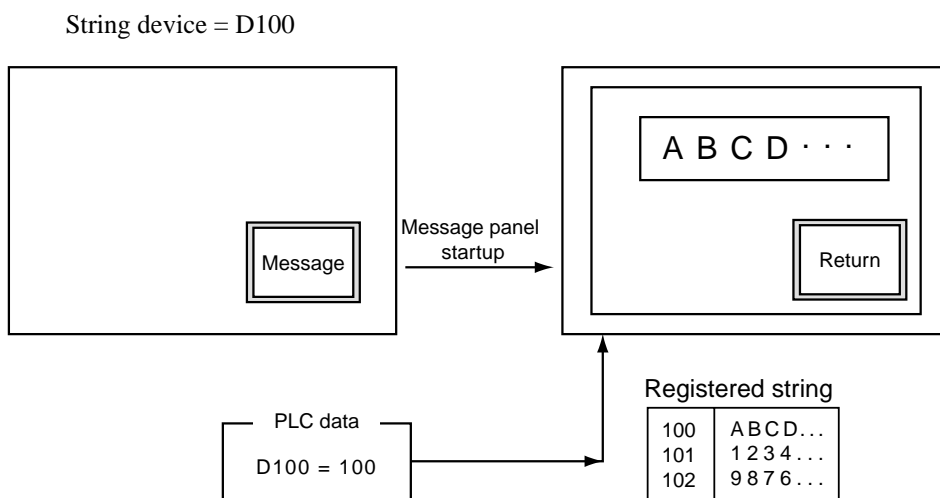

■ Smart Object Parameters

Parameter type	Parameter name	Selection/setting item	Remarks
Basic	String device	Enter the communications channel, device address and word device.	
	Panel	Enter the message panel No. to be called up.	
	Coordinates	Enter the call coordinates of the message panel.	
	Lamp device	Enter the communications channel, the device address, and the bit device.	
	Hide device	Enter the communications channel, the device address, and the bit device.	When lamp devices are used
Graphic	Type	Select the graphic type from general/user.	
	OFF Graphic	Select the graphic displayed at OFF.	
	Color when OFF	Select the display color of the OFF Graphic.	
	Blink when OFF	Select to cause blinking at OFF.	When lamp devices are used
	ON Graphic	Select the display graphic when the lamp is ON.	When lamp devices are used
	Color when ON	Select the display color of the graphic when the lamp is ON.	When lamp devices are used
	Blink when ON	Select to cause blinking when the lamp is ON.	When lamp devices are used
Text	Font size	Select the font size from 8 and 16 dots.	
	V alignment	Select vertical alignment from top/center/bottom.	
	H alignment	Select horizontal alignment from left/center/right.	
	Horizontal scale	Enter the horizontal scale of the string.	1 to 8
	Vertical scale	Enter the vertical scale of the string.	1 to 8
	OFF string	Enter the display text at OFF.	
	OFF color	Enter the display text color when OFF.	
	Blink when OFF	Select to cause blinking when OFF.	When lamp devices are used
	ON string	Enter the display text when the lamp is ON.	When lamp devices are used
	ON color	Select the display text color when the lamp is ON.	When lamp devices are used
	Blink when ON	Select to cause blinking when the lamp is ON.	When lamp devices are used

■ Supplementary Explanation

- For details on the message panel, see “5-5 Messages” (page 5-12).
- Set a binary data value within the range 1 to 1999 to the string data.
- For details on smart object settings, see “2-2 Main Configuration Items for Smart Objects” (page 2-5).

! Handling Precautions

- Be sure to enter a multiple of 16 when entering the bit device to the character string data device.
- Enter the word device on the PLC as the lamp/Hide device. Do not enter word devices such as registers.
- When an unregistered registered string No. is set, the string is not displayed on the message panel.
- When an opened pop-up panel is active, message panels cannot be called up by this panel.

3 - 9 Keyboard Call

Smart object name	Numeric keypad					
Type	Keyboard call					
				Scaling		Paste coordinates
Enlarge	Reduce	Reshape	Scaling factor	Text size		
○	○		Integer multiple	Interlocked	Any	

■ Function

- This smart object calls up the numeric keypad panel as a pop-up panel, and stops the startup source panel and other active panels when a switch is touched.
- On the numeric keypad panel, the data can be written to the write device on the PLC.
- Selecting “With calculation” executes calculation processing on the value entered on the numeric keypad panel, and writes the result of that calculation to the write device.
- The data write timing can be notified to the PLC.
- When entry of data on the numeric keypad ends, the numeric keypad closes, and the state before the numeric keypad was called is returned to.
- The coordinates of the numeric keypad to call can be specified.

■ Configuration

● Basic

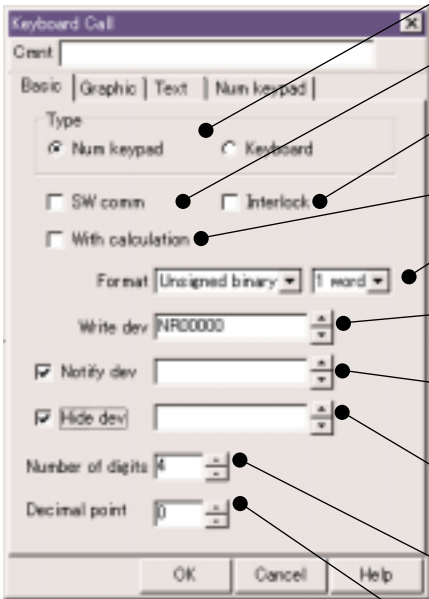

The screenshot shows the 'Keyboard Call' configuration dialog box with the following settings and callouts:

- [Type]**: This item is for selecting the type of keyboard call smart object. (Callout points to the 'Num keypad' radio button.)
- [SW comm]**: Select this item when using switch communications functions. (Callout points to the 'SW comm' checkbox.)
- [Interlock]**: Select this item when using the interlock function. (Callout points to the 'Interlock' checkbox.)
- [With calculation]**: Select this item when using the calculation function. (Callout points to the 'With calculation' checkbox.)
- [Format]**: This item is for selecting the format of the data to be entered on the numeric keypad panel. (Callout points to the 'Format' dropdown menu.)
- [Write device]**: This item is for entering the word device when data entered on the numeric keypad is written. (Callout points to the 'Write dev' text box.)
- [Notify device]**: This item is for entering the bit device to be set (turned ON) at completion of writing of the data entered on the numeric keypad. (Callout points to the 'Notify dev' text box.)
- [Hide device]**: This item is for entering the bit device for clearing the switch graphic or text display. (Callout points to the 'Hide dev' text box.)
- [Number of digits]**: This item is for entering the number of numeric display digits on the numeric keypad panel. (Callout points to the 'Number of digits' spin box.)
- [Decimal point]**: This item is for entering the decimal point position on the numeric keypad panel. (Callout points to the 'Decimal point' spin box.)

• Notify device

The bit of the notify device is set to ON when the data entered on the numeric keypad panel is written.

The EST does not reset the notify device to OFF. Set the device on the PLC after confirming the ON state of the bit.

● **Graphic**

Set the switch graphic to be displayed on the smart object and the display color of the graphic.

The graphic setting becomes OFF Graphic and ON Graphic. ON Graphic is the display graphic in a numeric keypad called up state.

● **Text**

Set the string to be displayed on the smart object and the display text color.

The string setting becomes OFF string and ON string. ON string is the display text in a numeric keypad called up state.

● **Calculation**

This sheet is for executing calculation processing on data entered on the numeric keypad panel.



[Write calculation data]

Calculation processing preset at Write calculation data is performed on the data entered on the numeric keypad panel, and the result of that calculation is written to the write device.

● **Write calculation data**

This setting is enabled when With calculation has been selected.

The calculation processing set at Write calculation data is executed on the data entered on the numeric keypad panel.

The data after calculation processing is written to the write device.

[Example]

Write device = D100, numeric keypad entry data = 100, calculation mode = add, calculation device = 10

The data to be written to D100 becomes $100 + 10 = 110$

● Numeric keypad

This sheet is for setting the numeric keypad panel when the numeric keypad is used.

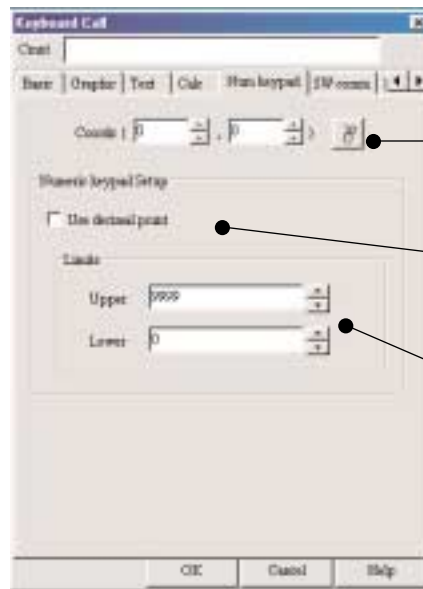

[Coordinates]

This item is for entering the call coordinates of the numeric keypad panel.

[Use decimal point]

Select this item when a numeric keypad panel with decimal point entry is to be used.

[Upper/lower]

This item is for entering the data entry upper/lower limit values on the numeric keypad panel.

- Use decimal point

Call the numeric keypad panel having a decimal point entry function.

For details on the numeric keypad panel, see “5-2 Numeric Keypad” (page 5-4).

- Upper/Lower

Enter the valid range of the data when the data is set on the numeric keypad panel.

When the data entered on the numeric keypad panel exceeds the valid range when the [ENT] key is touched, an error occurs, a short, high-pitched alarm buzzers, and the set data is cleared to “0”.

[Data entry range]

Upper limit value \geq Setting data \geq Lower limit value

● Switch Communications

This sheet is for setting the operation of switch communications functions.

● Interlock

This sheet is for setting the entry enabled conditions for the switch.

■ Example

Write device = D100, number of digits = 4, decimal point position = 1, notify device = M000, numeric keypad entry upper limit value = 1500, numeric keypad entry lower limit value = 100

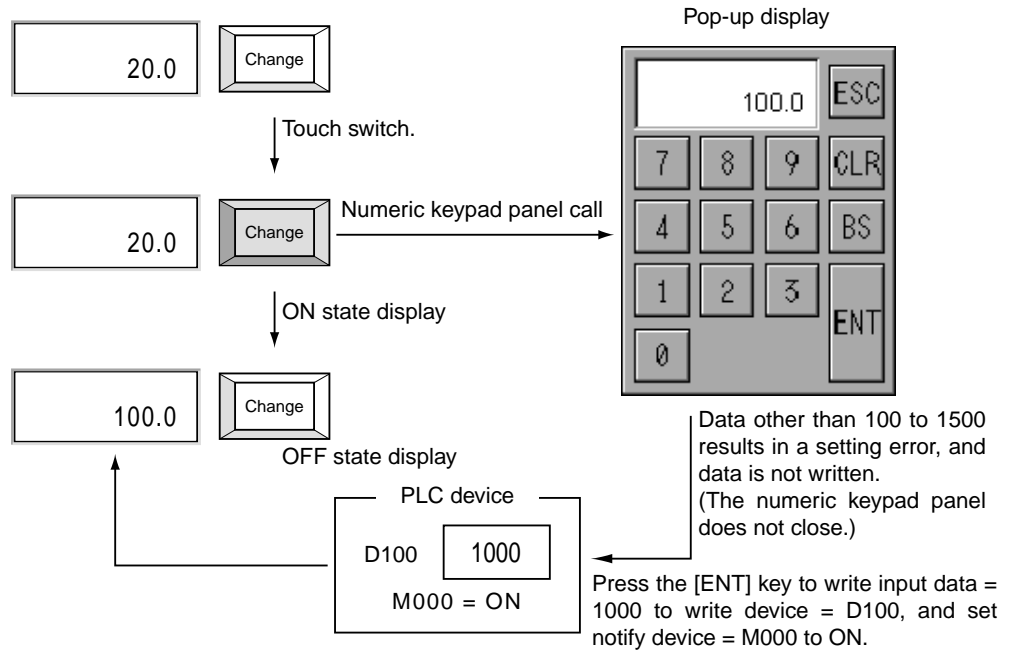

■ Smart Object Parameters

Tab name	Parameter name	Selection/setting item	Remarks
Basic	Format	Select the data format of the write device.	
	Write device	Enter the communications channel, the device address, and the word device.	
	Notify device	Enter the communications channel, the device address, and the bit device.	
	Hide device	Enter the communications channel, the device address, and the bit device.	
	Number of digits	Enter the number of display digits of the numeric data on the numeric keypad.	
	Decimal point	Enter the display position of the decimal point on the numeric keypad.	
	With calculation	Select when calculation functions are used.	
	SW comm	Select when using switch communications.	
	Interlock	Select when using interlocked operation.	
Graphic	Type	Select the graphic type from general/user.	
	OFF Graphic	Select the display OFF Graphic.	
	Color when OFF	Select the display color of the OFF Graphic.	
	Blink when OFF	Select to cause blinking when OFF.	
	ON Graphic	Select the display graphic when the numeric keypad is called up.	
	Color when ON	Select the graphic display color when the numeric keypad is called up.	
Text	Blink when ON	Select to cause blinking when the numeric keypad is called up.	
	Font size	Select the font size from 8 and 16 dots.	
	V alignment	Select vertical alignment from top/center/bottom.	
	H alignment	Select horizontal alignment from left/center/right.	1 to 8
	Horizontal scale	Enter the horizontal scale of the string.	1 to 8
	Vertical scale	Enter the vertical scale of the string.	
	OFF string	Enter the display text when OFF.	
	OFF color	Enter the display text color when OFF.	
	Blink when OFF	Select to cause blinking when OFF.	
	ON string	Enter the display string when the numeric keypad is called up.	
Calculation	ON color	Select the display text color when the numeric keypad is called up.	
	Blink when ON	Select to cause blinking when the numeric keypad is called up.	
Calculation	Calculation mode	Select the calculation mode for the write data from add/subtract/multiple/divide.	
	Calculation device	Enter the constant or the communications channel, the device address, and the word device.	
Numeric keypad	Coordinates	Enter the call coordinates of the numeric keypad panel.	
	Use decimal point	Select the numeric keypad panel with decimal point entry.	
	Entered upper limit value	Enter the upper limit value of the input data on the numeric keypad.	
	Entered lower limit value	Enter the lower limit value of the input data on the numeric keypad.	-32768 to +32767
Switch communications	Switch code	Enter the switch code.	
	Switch communications function	Select the switch communications function.	
Interlock	Bit state	Interlock action according to ON/OFF state of bit device	
	Range	Interlock action according to bit device range	

■ Supplementary Explanation

- When 2-word data is to be displayed, the relationship between PLC devices and display is as follows.

[Example] Numeric device = D100, data format = Hex, 2 words, number of digits = 8

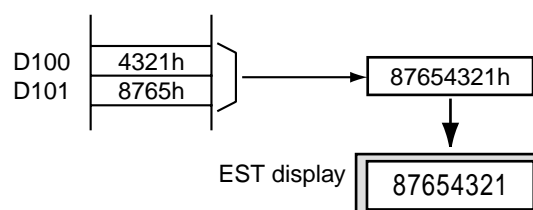

- For details on smart object settings, see “2-2 Main Configuration Items for Smart Objects” (page 2-5).

Handling Precautions

- Be sure to enter a multiple of 16 when entering the bit device to the numeric/write device.
- When displaying 2-word data, do not enter the final address of the PLC as the numeric/write device.
- Enter the bit device on the PLC for Clear/Notify devices. Do not enter word devices such as registers.
- When a calculation error (underflow/overflow) occurs in write calculation, the data set on the numeric keypad is not written. (The notify device also is not set to ON.)
Note, however, that the numeric keypad panel closes.
- Numeric keypad panels cannot be started up when a started up pop-up panel is currently active.

Smart object name	Keyboard					
Type	Keyboard call					
	Scaling					Paste coordinates
	Enlarge	Reduce	Reshape	Scaling factor	Text size	
	○	○	○	Any	Fixed	Any

■ Function

- This smart object calls up the keyboard panel as a pop-up panel, and stops the startup source panel and other active panels when a switch is touched.
- On the keyboard panel, the data can be written to the write device on the PLC.
- The data write timing can be notified to the PLC.
- When entry of data on the keyboard panel ends, the keyboard panel closes, and the state before the keyboard panel was called is returned to.
- The coordinates of the keyboard panel to be called up can be specified.

■ Configuration

● Basic

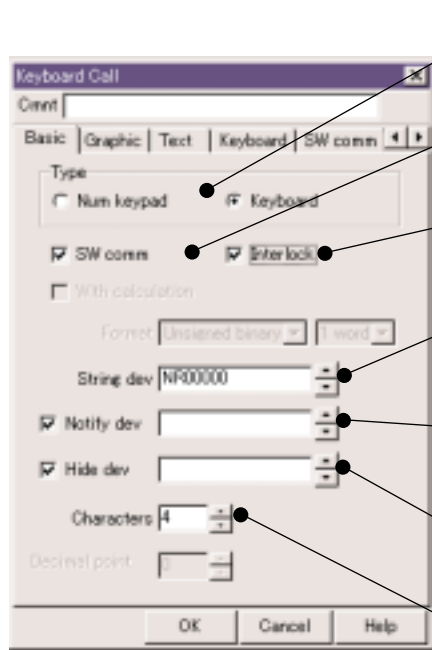

The screenshot shows the 'Keyboard Call' dialog box with the following settings and callouts:

- [Type]**: Points to the 'Keyboard' radio button under the 'Type' section.
- [SW comm]**: Points to the checked 'SW comm' checkbox.
- [Interlock]**: Points to the checked 'Interlock' checkbox.
- [String device]**: Points to the 'String dev' text box containing 'N100000'.
- [Notify device]**: Points to the 'Notify dev' text box.
- [Hide device]**: Points to the 'Hide dev' text box.
- [Characters]**: Points to the 'Characters' spin box set to '4'.

Additional callouts on the right side of the image provide detailed descriptions for each setting:

- [Type]**: This item is for selecting the type of keyboard call smart object.
- [SW comm]**: Select this item when using switch communications functions.
- [Interlock]**: Select this item when using the interlock function.
- [String device]**: This item is for entering the word device on the PLC for writing the string data entered on the keyboard panel.
- [Notify device]**: This item is for entering the bit device to be set (turned ON) at completion of writing of the data entered on the numeric keypad.
- [Hide device]**: This item is for entering the bit device for clearing the switch graphic or text display.
- [Characters]**: This item is for entering the number of characters that can be entered on the keyboard panel by 2-byte conversion.

- **String device**
Enter the start device on the PLC for writing the string data entered on the keyboard panel.
- **Notify device**
The bit of the notify device is set to ON when the data entered on the numeric keypad panel is written.
The EST does not reset the notify device to OFF. Set the device on the PLC after confirming the ON state of the bit.
- **Characters**
Enter the number of characters that can be entered on the keyboard panel by 2-byte conversion. For example, set "3" for six 1-byte characters and "2" for three 1-byte characters.

● **Graphic**

Set the switch graphic to be displayed on the smart object and the display color of the graphic.

The graphic setting becomes OFF Graphic and ON Graphic. ON Graphic is the display graphic in a keyboard called up state.

● **Text**

Set the string to be displayed on the smart object and the display text color.

The string setting becomes OFF string and ON string. ON string is the display text in a keyboard called up state.

● **Keyboard**

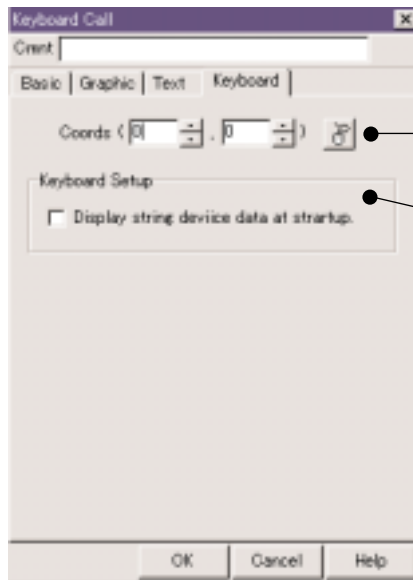

[Coordinates]
This item is for entering the call coordinates of the keyboard panel.

[Keyboard Setup]
This item is for selecting the data display method of the input data display field when the keyboard panel is called up.

• **Keyboard setup**

When the “Display string device data at startup” checkbox is marked, the string data currently set to the string device is displayed at the input data display field when the keyboard panel is displayed.

● **Switch Communications**

This sheet is for setting the operation of switch communications functions.

● **Interlock**

This sheet is for setting the entry enabled conditions for the switch.

■ Example

String device = D100, number of display characters = 6, notify device = M000

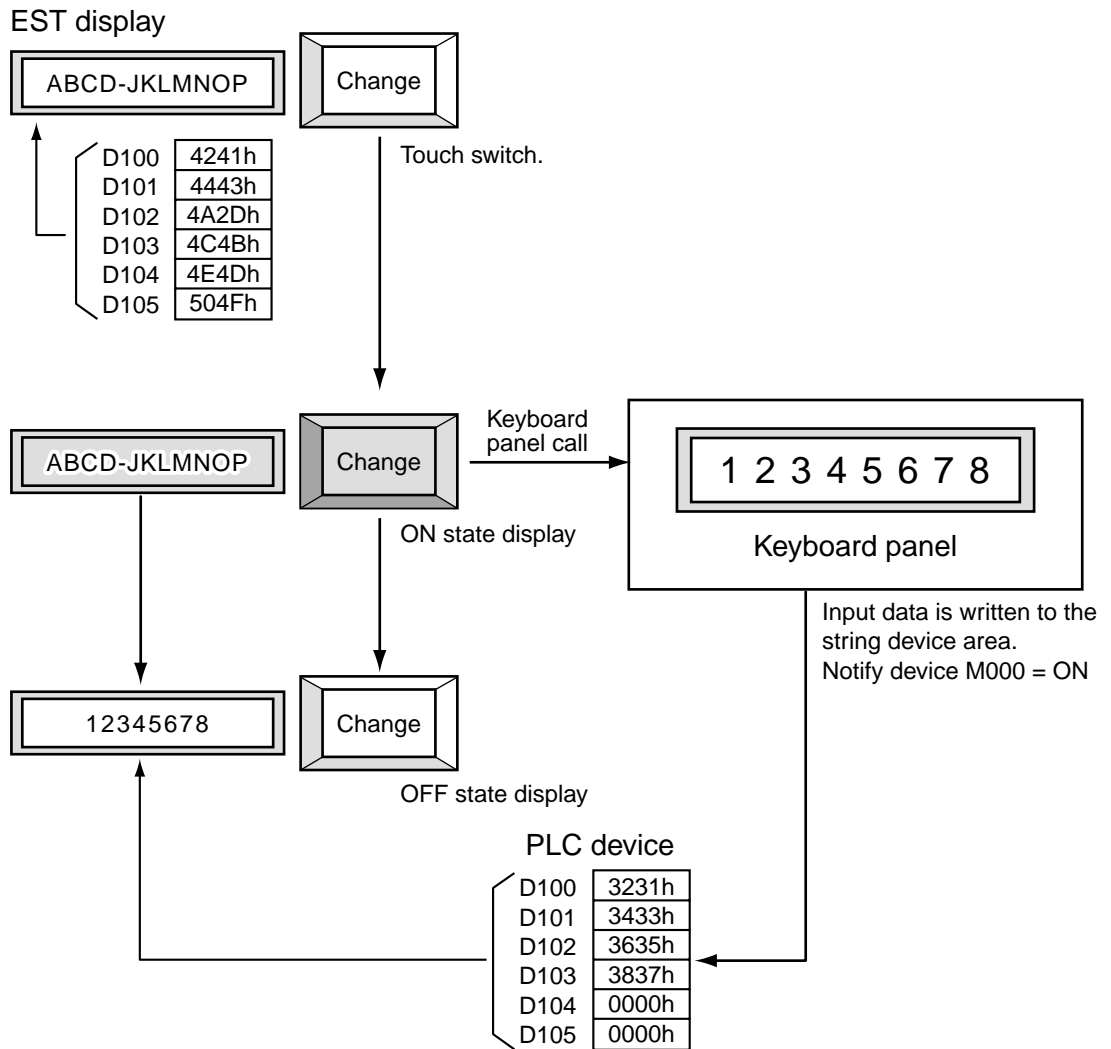

■ Smart Object Parameters

Tab name	Parameter name	Selection/setting item	Remarks
Basic	String device	Enter the communications channel, the device address, and the word device.	
	Notify device	Enter the communications channel, the device address, and the bit device.	
	Hide device	Enter the communications channel, the device address, and the bit device.	
	Characters	Enter the number of characters that can be entered.	1 to 64
	SW comm	Select when using switch communications.	
	Interlock	Select when using interlocked operation.	
Graphic	Type	Select the graphic type from general/user.	
	OFF Graphic	Select the display OFF Graphic.	
	Color when OFF	Select the display color of the OFF Graphic.	
	Blink when OFF	Select to cause blinking when OFF.	
	ON Graphic	Select the display graphic when the numeric keypad is called up.	
	Color when ON	Select the graphic display color when the numeric keypad is called up.	
	Blink when ON	Select to cause blinking when the numeric keypad is called up.	
Text	Font size	Select the font size from 8 and 16 dots.	
	V alignment	Select vertical alignment from top/center/bottom.	
	H alignment	Select horizontal alignment from left/center/right.	
	Horizontal scale	Enter the horizontal scale of the string.	1 to 8
	Vertical scale	Enter the vertical scale of the string.	1 to 8
	OFF string	Enter the display text at OFF.	
	OFF color	Enter the display text color when OFF.	
	Blink when OFF	Select to cause blinking at OFF.	
	ON string	Enter the display string when the numeric keypad is called up.	
	ON color	Select the display text color when the numeric keypad is called up.	
Keyboard	Coordinates	Enter the call coordinates of the keyboard panel.	-32768 to +32767
	Keyboard setup	Select the display setting when the keyboard panel is called up.	
Switch communications	Switch code	Enter the switch code.	
	Switch communications function	Select the switch communications function.	
Interlock	Bit state	Interlock action according to ON/OFF state of bit device	
	Range	Interlock action according to bit device range	

■ Supplementary Explanation

- For details on smart object settings, see "2-2 Main Configuration Items for Smart Objects" (page 2-5).
- For details on the keyboard panel, see "5-3 Keyboard" (page 5-8).

Handling Precautions

- Enter the word device on the PLC as the String device. Do not enter bit devices such as relays.
- Enter the bit device on the PLC as the Notification/Hide device. Do not enter word devices such as registers.
- When a registered graphic is used for the switch graphic, the OFF graphic and ON graphic to be displayed must be created at the same size.
- When a registered graphic is used for the switch graphic, the smart object size becomes the size of the graphic, and the smart object cannot be scaled.
- When an opened pop-up panel is active, numeric keypad panels cannot be started.
- When the number of entered characters on the keyboard panel is less than the number of characters to be called from the PLC, "00 Hex" is written to areas to which strings are not entered. "00 Hex" is not written when the number of characters entered on the keyboard panel is the same as the number of characters to be called from the PLC.

3 - 10 Data Setter

Smart object name	Password numeric keypad				
Type	Data setter				
Scaling					Paste coordinates
Enlarge	Reduce	Reshape	Scaling factor	Text size	
			—	Fixed	Any

■ Function

- These smart objects set 8-digit BCD on the PLC (2-word data: 0 to 99999999).
- The numeric value being entered is not displayed on the numeric keypad, and “*” is displayed instead of the numeric value for each entered digit.
- Pressing the Return key writes the numeric value to the write device on the PLC.

■ Configuration

● Basic

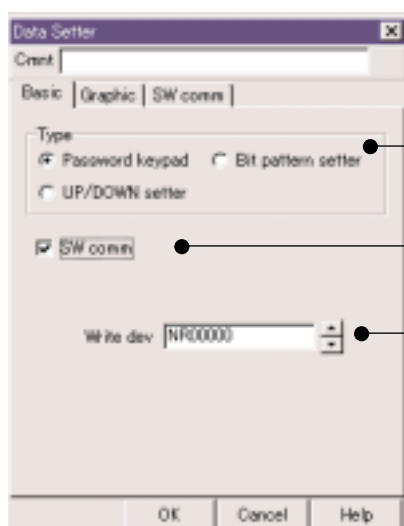

[Type]

This item is for selecting the type of data setter smart object.

[SW comm]

Select this item when using switch communications functions.

[Write device]

This item is for entering the word device to which data entered on the numeric keypad is entered.

- Write device
Write data is 2-word numeric data.
Enter the start word register on the PLC to write the data to as the write device.

● Graphic

This sheet is for setting the graphic to be displayed on the smart object and the display color of the graphic.

● Switch communications

Set the operation of switch communications functions.

■ Example

Write device = D100

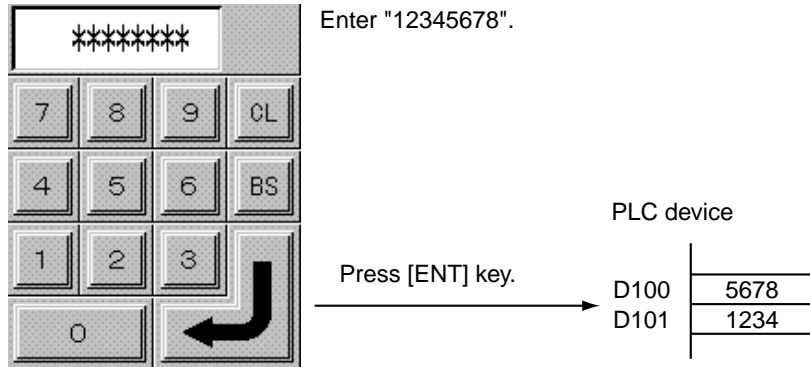

■ Smart Object Parameters

Tab name	Parameter name	Selection/setting item	Remarks
Basic	Write device	Enter the communications channel, the device address, and the word device.	
	SW comm	Select when using switch communications.	
Graphic	Type	Select the general graphic.	
	No.	Select the display graphic of the password numeric keypad.	
	Color	Select the display color of the graphic.	
Switch communications	Switch code	Enter the switch code.	
	Switch communications function	Select the switch communications function.	

■ Supplementary Explanation

- Write data is 2-word data. Even if the data entered on the numeric keypad is data of four digits or less, the data is written to the write device on the PLC as 2-word data.
- For details on smart object settings, see “2-2 Main Configuration Items for Smart Objects” (page 2-5).

! Handling Precautions

- Enter the multiple of 16 when entering the bit device to the write destination device.
- Do not enter the final address of the PLC to the write device.

Smart object name	UP/DOWN setter				
Type	Data setter				
Scaling					Paste coordinates
Enlarge	Reduce	Reshape	Scaling factor	Text size	
<input type="radio"/>	<input type="radio"/>		Integer multiple	Interlocked	Any

■ Function

- This smart object displays 1-word data of the numeric device on the PLC.
- Numeric values are incremented or decremented by touching the up arrow \triangle key or the down arrow ∇ key. The numeric value is written to the PLC by releasing the key.
- Holding down the keys fast-feeds incrementing and decrementing.
- The input upper limit value and the input lower limit value can be set.

■ Configuration

● Basic

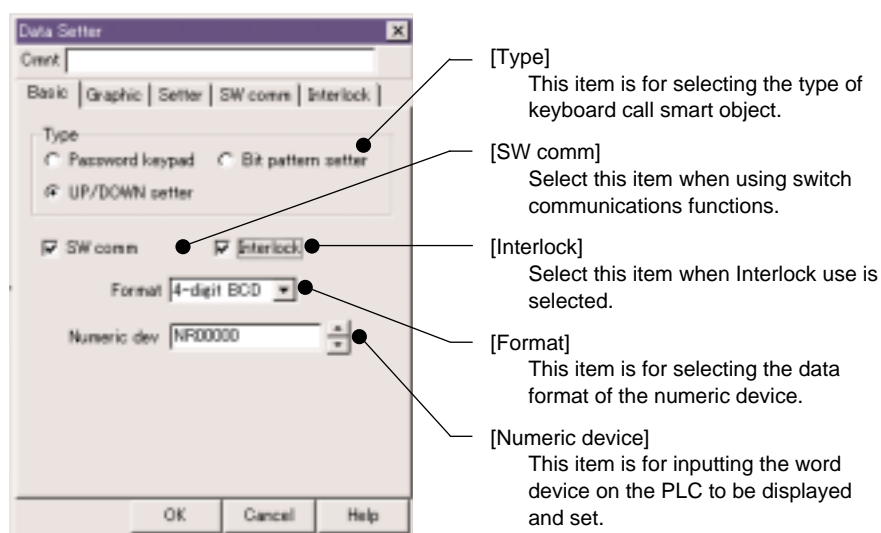

● Format

- Select the data format for the numeric device from 4-digit BCD/5-digit binary.
- 4-digit BCD: Set BCD data within the range 0 to 9999.
- 5-digit binary: Set signed binary data within the range -32768 to +32767.

● Graphic

This sheet is for setting the graphic to be displayed on the smart object and the display color of the graphic.

● **Setter**

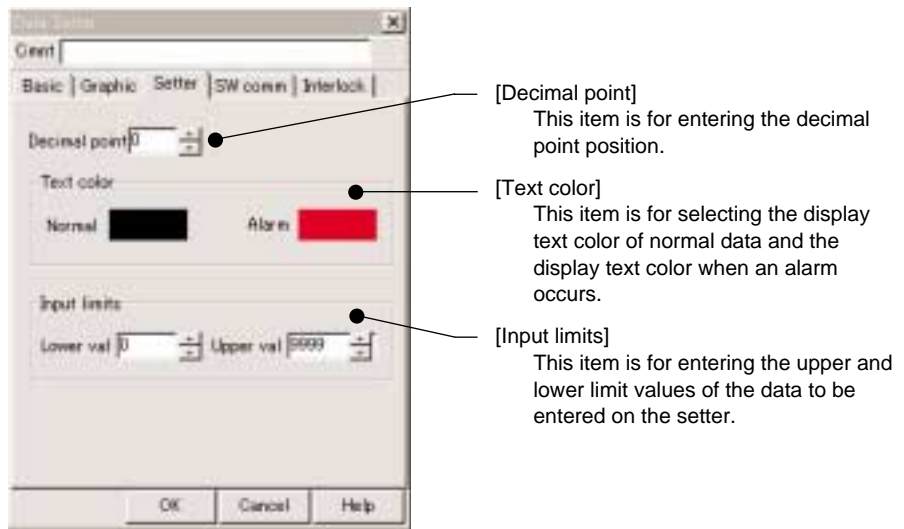

- **Text color**
 Select the display text color of the numeric data.
 Display color: Select the display text color of normal data.
 Alarm display color: Select the display text color when the set data exceeds the upper and lower limit values of the entry restrictions.
- **Input limits**
 Enter the range of the data to be input on the setter.
 The upper and lower limit values are written to the numeric device when the set data exceeds the upper and lower limit values.

● **Switch Communications**

This sheet is for setting the operation of switch communications functions.

● **Interlock**

This sheet is for setting the entry enabled conditions for the switch.

■ **Example**

Numeric device= D100

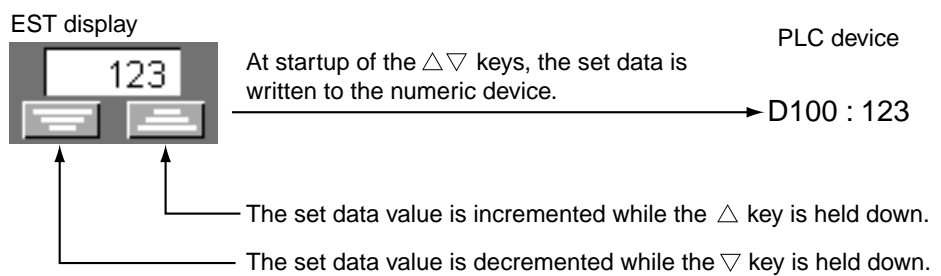

■ Smart Object Parameters

Tab name	Parameter name	Selection/setting item	Remarks
Basic	Format	Select the data format of the setter from 4-digit BCD/5-digit binary.	
	Numeric device	Enter the communications channel, the device address, and the word device.	
	SW comm	Select when using switch communications.	
	Interlock	Select when using the interlock function	
Graphic	Type	Select the general graphic.	
	No.	Select the display graphic of the UP/DOWN setter.	
	Color	Select the display color of the graphic.	
Setter	Decimal point	Enter the display position of the decimal point.	4-digit BCD: 0 to 3 5-digit binary: 0 to 4
	Normal	Select the display text color of the numeric value.	
	Alarm	Select the display text color when the upper/lower limit values are exceeded.	
	Upper value	Enter the upper limit value when the data is updated.	4-digit BCD: 0 to 9999 5-digit binary: -32768 to +32767
	Lower value	Enter the lower limit value when the data is updated.	4-digit BCD: 0 to 9999 5-digit binary: -32768 to +32767
Switch communication	Switch code	Enter the switch code.	-32768 to +32767
	Switch communications function	Select the switch communications function.	
Interlock	Bit state	Interlock operation according to bit device ON/OFF	
	Range	Interlock operation according to the data device range	

■ Supplementary Explanation

- Numeric data when 4-digit BCD is selected as the data format is displayed without zeros suppressed.
- Numeric data when 5-digit binary is selected as the data format is displayed with zeros suppressed. Data is displayed at signed binary.
- Of the numeric value exceeds the upper and lower limit values with each press of the \triangle and ∇ keys, the numeric value blinks at the alarm text color, and a short, high-pitched alarm buzzers.
- For details on smart object settings, see "2-2 Main Configuration Items for Smart Objects" (page 2-5).

Handling Precautions

- Be sure to enter a multiple of 16 when entering the bit device of the PLC to the numeric device.
- Do not change the data of the numeric device on other smart objects or internally on the PLC. Doing so might prevent correct operation.
- When 4-digit BCD is selected as the data format, operation may not be correct if data other than BCD is entered to the numeric device.

Smart object name	Bit pattern setter					
Type	Data setter					
					Scaling	
			Enlarge	Reduce	Reshape	Paste coordinates
			○	○	○	Any
			Scaling factor		Text size	Any
			Any		Fixed	

Function

- The setter can set the ON/OFF states of eight continuous switch devices.
- Each press of the switch changes the ON/OFF states of the switch devices.
- The switch graphic changes according to the ON/OFF state of the eight continuous lamp devices.

Configuration

● **Basic**

The screenshot shows the 'Data Setter' dialog box with the following callouts:

- [Type]**: This item is for selecting the type of keyboard call smart object.
- [SW comm]**: Select this item when using switch communications functions.
- [Interlock]**: Select this item when Interlock use is selected.
- [Switch device]**: This item is for entering the start bit device to be manipulated when a switch is touched.
- [Lamp device]**: This item is for entering the start bit device to be monitored for switching the graphic display.
- [Hide device]**: This item is for entering the bit device for clearing the graphic display.

- **Switch device**
Set the ON/OFF states of continuous eight bits starting from the bit device entered to the switch device.
- **Lamp device**
Set the ON/OFF states of continuous eight bits starting from the bit device entered to the lamp device.

● **Graphic**

Set the display OFF Graphic/ON to be displayed on the smart object and the display color of the graphic.

● **Switch Communications**

Set the operation of switch communications functions.

● **Interlock**

Set the entry enabled conditions for the switch.

■ Example

Switch device = M000, lamp device = M010

Switch device M007 M006 M005 M004 M003 M002 M001 M000

Lamp device M017 M016 M015 M014 M013 M012 M011 M010



Writes M006 = ON
when the switch is
touched.

Writes M002 = OFF
when the switch is
touched.

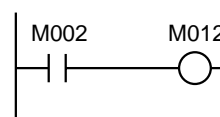
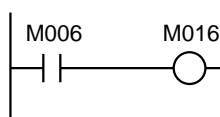

■ Smart Object parameters

Parameter type	Parameter name	Selection/setting item	Remarks
Basic	Switch device	Enter the communications channel, the device address, and the bit device.	
	Lamp device	Enter the communications channel, the device address, and the bit device.	
	Hide device	Enter the communications channel, the device address, and the bit device.	
	SW comm	Select when using switch communications.	
	Interlock	Select when using interlocked operation.	
Graphic	Type	Select the general graphic.	
	OFF Graphic	Select the graphic displayed at OFF.	
	Color when OFF	Select the display color of the OFF Graphic.	
	ON Graphic	Select the display graphic when the lamp is ON.	
	Color when ON	Select the display color of the graphic when the lamp is ON.	
Switch communications	Switch code	Enter the switch code.	-32768 to +32767
	Switch communications function	Select the switch communications function.	
Interlock	Bit state	Interlock action according to ON/OFF state of bit device	
	Range	Interlock action according to bit device range	

■ Supplementary explanation

- Select the OFF graphic for the graphic selection. The ON graphic is paired with the OFF graphic and is automatically selected.
- Each of the bits of switch and lamp devices is assigned in order to switches from right to left.
- Switch devices may be the same as lamp devices.
- For details on smart object settings, see “2-2 Main Configuration Items for Smart Objects” (page 2-5).

! Handling Precautions

- Enter the bit device on the PLC for the Switch device, Lamp device and Hide device. Do not enter word devices such as registers.

3 - 11 Alarm Monitor

Smart object name	Aggregation lamp [alarm lamp]				
Type	Alarm monitor				
	Scaling				Paste coordinates
	Enlarge	Reduce	Reshape	Scaling factor	Text size
	<input type="radio"/>	<input type="radio"/>		Integer multiple	Fixed
					Any

■ Function

- This smart object displays the alarm name of the contact registered to the alarm monitoring information of the application data.
- The display graphic is switched when an alarm occurs.
- The number of displays can be selected from 8/5/4/1 so that continuous alarm names can be displayed.
- Touching the alarm name displays the alarm message panel or the pop-up panel created by the user, and stops the startup source panel and other active panels.
- The coordinates of the panel to be called up can be specified.

■ Configuration

● Basic

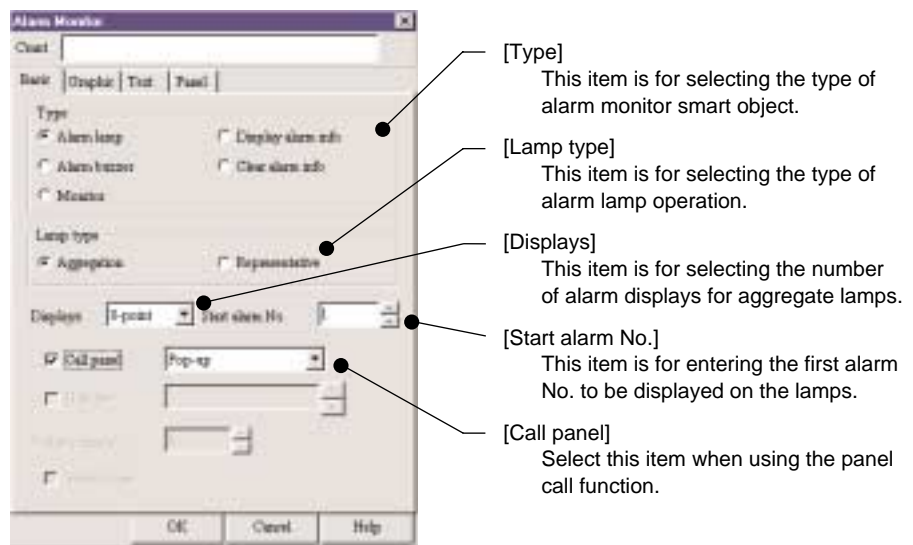

● Graphic

Set the OFF/ON Graphic to be displayed on the smart object and the display color of the graphic.

● Text

Set the display text color when OFF/ON to be displayed on the smart object. The entry field for the display string is not available as the alarm name set to the alarm monitoring information is displayed on the smart object.

● Panel

This sheet is for setting the panel call when [Call panel] is selected.

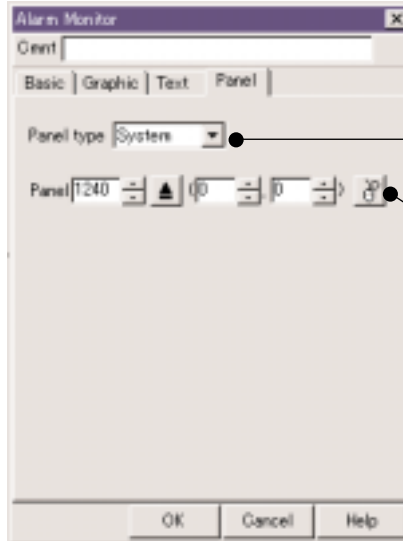

- [Panel type]
This item is for selecting the type of panel to be called.
- [Panel]
This item is for entering the panel No. to be called and the call coordinates.

• Panel type

Select the type of panel to be called when the switch is touched.

[System]

Call up the alarm message panel (system panel) as a pop-up panel.

On the alarm message panel, the alarm message corresponding to the alarm No. is displayed.

For details on the alarm message panel, see “5-6 Alarm Messages” (page 5-14).

[User]

Select this item when the alarm details are to be created freely.

The user panel is called up as a pop-up panel.

For the user panels to be called up, continuous panel Nos. are set as the call panels for each alarm display starting from the panel No. set by panel entry.

Be sure to paste a “Pop-up return” smart object on user panels that are called up.

■ Example

Number of displays = 4, start alarm No. = 100, panel call selected, panel type = user, panel No. = 300

EST display

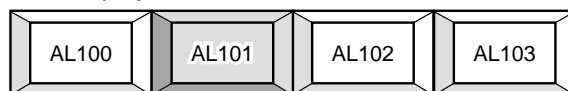

When the
switch is
touched:
Panel No. 300
pop-up

When the
switch is
touched:
Panel No. 301
pop-up

When the
switch is
touched:
Panel No. 302
pop-up

When the
switch is
touched:
Panel No. 303
pop-up

Alarm monitor information

Alarm No.	Alarm Name	Alarm Bit
100	AL100	M010= OFF
101	AL101	M011= ON
102	AL102	M012= OFF
103	AL103	M013= OFF

■ Smart Object Parameters

Parameter type	Parameter name	Selection/setting item	Remarks
Basic	Displays	Select the number of display points for the lamp from 8/5/4/1.	
	Start alarm No.	Enter the start alarm No. to be displayed as an alarm.	Number of display points 8: 1 to 505 Number of display points 5: 1 to 508 Number of display points 4: 1 to 509 Number of display points 1: 1 to 512
	Call panel	Select when the panel call function is used.	
Graphic	Type	Select general.	
	OFF Graphic	Select the display graphic when the alarm is OFF.	
	Color when OFF	Select the display color of the graphic when the alarm is OFF.	
	Blink when OFF	Select to cause blinking when the alarm is OFF.	
	ON Graphic	Select the display graphic when the alarm is ON.	
	Color when ON	Select the graphic display color when the alarm is ON.	
Text	Blink when ON	Select to cause blinking when the alarm is ON.	
	V alignment	Select vertical alignment from top/center/bottom.	
	H alignment	Select horizontal alignment from left/center/right.	
	Horizontal scale	Enter the horizontal scale of the string.	1 to 8
	Vertical scale	Enter the vertical scale of the string.	1 to 8
	OFF color	Select the display text color when the alarm is OFF.	
	Blink when OFF	Select to cause blinking when the alarm is OFF.	
	ON color	Enter the display text color when the alarm is ON.	
Panel	Blink when ON	Select to cause blinking when the alarm is ON.	
	Panel type	Select the panel type to be called up from system/user.	
	Panel	Enter the panel No. to be called up.	System: 1240 to 1249 User: 1 to 899
	Coordinates	Enter the call coordinates of the panel.	

■ Supplementary Explanation

- Select OFF graphic for the graphic selection. OFF graphic is paired with ON graphic and is automatically selected.
- For details on smart object settings, see “2-2 Main Configuration Items for Smart Objects” (page 2-5).
- The alarm monitor contacts, the alarm names, and the messages are registered at [Set Alarms] in AP Editor. For details, see the Smart Terminal EST240Z User’s Manual Application Preparation Manual No.CP-SP-1088E.

! Handling Precautions

- Do not use this smart object for panels that are to be started up as pop-up panels when panel call is selected. The panel cannot be started up by touching the alarm name field.
- The panel is not started up if the pop-up panel is not registered when calling of the user panel is selected.
- If the ON time of the alarm contacts is shorter than one alarm monitoring communications cycle, alarm monitoring may not function correctly.
- The display size of this smart object for each alarm is 40 x 40 dots. For this reason, the alarm name will be displayed using eight 1-byte characters unless the smart object is enlarged. To display all 16 characters, enlarge the characters by a scaling factor of two or more in the vertical or horizontal direction.

Smart object name	Representative lamp [alarm lamp]					
Type	Alarm monitor					
	Scaling				Paste coordinates	
	Enlarge	Reduce	Reshape	Scaling factor		Text size
	○		○	Integer multiple	Fixed	Any

■ Function

- This smart object switches the graphic display to the ON graphic when one of the alarm monitor contacts registered to the alarm monitoring information of the application data turns ON.
- The specified panel can be started up by touching a switch. At this time, the coordinates of the panel to be started up can be specified.

■ Configuration

● Basic

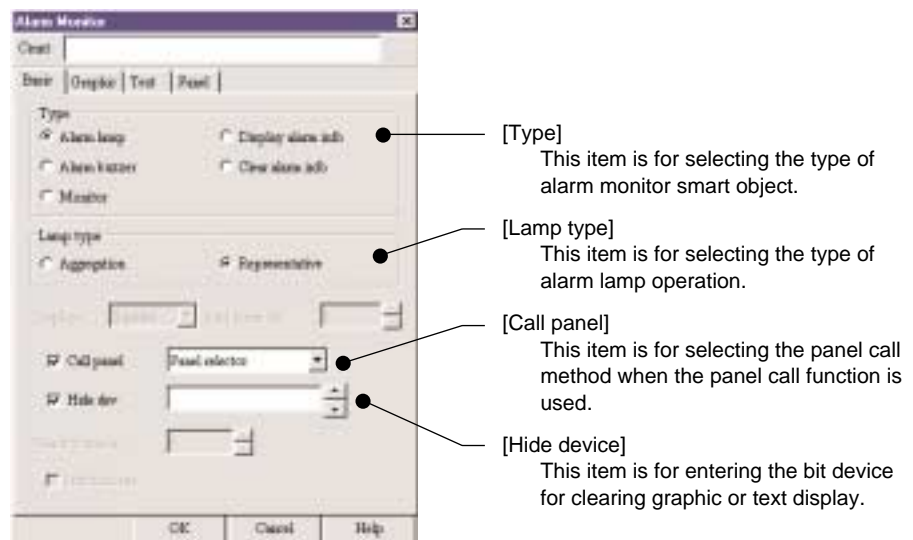

• Call panel

Select this item when the panel call function is used.

Select from Panel selector/Panel overlay as the call method.

[Panel selector]

The specified panel is started up, and the startup source panel and other active panels are stopped.

Parts that are not overwritten on the newly started up panel are not cleared and remain displayed.

Note, however, that updating of displays is stopped.

There is no change to operation of the background panel.

[Panel overlay]

The specified panel is displayed overlapping. The startup source panel and other active panels stay active.

Up to eight panels including the background panel can be started up simultaneously.

● **Graphic**

Set the OFF/ON Graphic to be displayed on the smart object and the display color of the graphic.

● **Text**

Set the display string at OFF/ON to be displayed on the smart object, the display string and the display text color.

● **Panel**

This sheet is for setting the panel call when [Call panel] is selected.



[Panel]
This item is for entering the panel No. to be called and the call coordinates.

■ **Example**

Panel call = panel selector, panel = 300

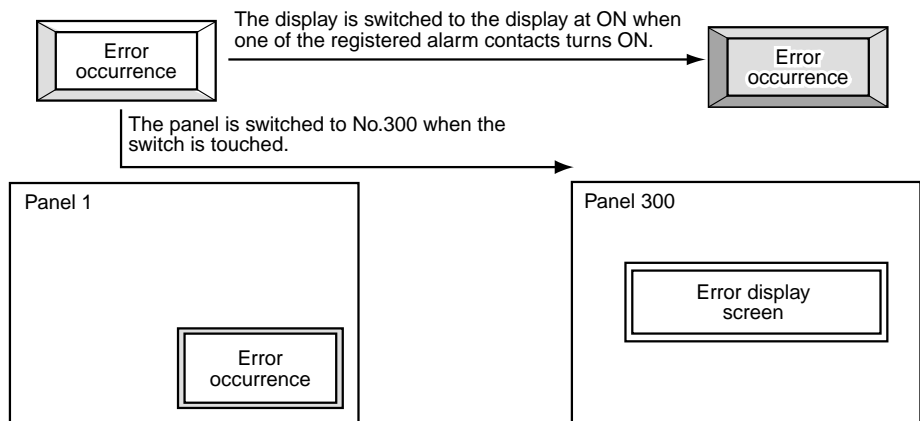

■ Smart Object Parameters

Parameter type	Parameter name	Selection/setting item	Remarks
Basic	Call panel	Select the panel startup method when the panel call-up function is used from panel selector/panel overlay.	
	Hide device	Enter the communications channel, the device address, and the bit device.	
Graphic	Type	Select general.	
	OFF Graphic	Select the display graphic when the alarm is OFF.	
	Color when OFF	Select the display color of the graphic when the alarm is OFF.	
	Blink when OFF	Select to cause blinking when the alarm is OFF.	
	ON Graphic	Select the display graphic when the alarm is ON.	
	Color when ON	Select the graphic display color when the alarm is ON.	
Text	Blink when ON	Select to cause blinking when the alarm is ON.	
	Font size	Select the font size from 8 and 16 dots.	
	V alignment	Select vertical alignment from top/center/bottom.	
	H alignment	Select horizontal alignment from left/center/right.	
	Horizontal scale	Enter the horizontal scale of the string.	1 to 8
	Vertical scale	Enter the vertical scale of the string.	1 to 8
	OFF string	Enter the display string when the alarm is OFF.	
	OFF color	Select the display text color when the alarm is OFF.	
	Blink when OFF	Select to cause blinking when the alarm is OFF.	
	ON string	Enter the display string when the alarm is ON.	
Panel	ON color	Enter the display text color when the alarm is ON.	
	Blink when ON	Select to cause blinking when the alarm is ON.	
	Panel	Enter the panel No. to be called up.	1 to 899
	Coordinates	Enter the call coordinates of the panel.	

■ Supplementary Explanation

- Select OFF graphic for the graphic selection. OFF graphic is paired with ON graphic and is automatically selected.
- For details on smart object settings, see “2-2 Main Configuration Items for Smart Objects” (page 2-5).
- The alarm monitor contacts, the alarm names, and the messages are registered at [Set Alarms] in AP Editor. For details, see the Smart Terminal EST240Z User’s Manual Application Preparation Manual No.CP-SP-1088E.

! Handling Precautions

- When an unregistered panel No. is entered when panel call is selected, the panel is not started up.
- When an opened pop-up panel is active when panel call is selected, panels cannot be started by this smart object.
- If the ON time of the alarm contacts is shorter than one alarm monitoring communications cycle, alarm monitoring may not function correctly.

Smart object name	Alarm buzzer					
Type	Alarm monitor					
	Scaling				Paste coordinates	
	Enlarge	Reduce	Reshape	Scaling factor		Text size
				—	—	Any

■ **Function**

- This smart object buzzes the alarm when one of the alarm monitor contacts registered to the alarm monitoring information of the application data turns ON.
- The alarm buzzes when a new alarm occurs.

■ **Configuration**

● **Basic**

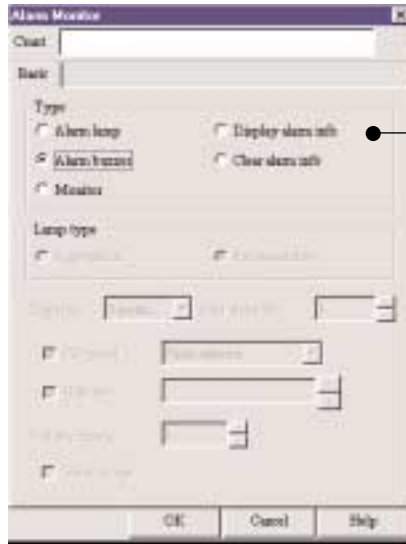

[Type]
This item is for selecting the type of alarm monitor smart object.

Setting items are not available.
Paste the alarm buzzer as it is on the panel.

■ **Example**

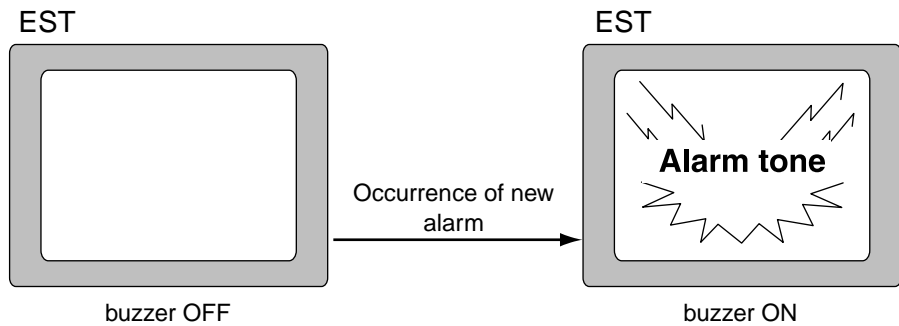

■ Smart Object Parameters

Parameter type	Parameter name	Selection/setting item	Remarks
Basic	Type	Select alarm buzzer.	

■ Supplementary Explanation

- Regular alarms can be monitored by pasting this smart object to the panel to be used as the background panel.
- Only functions are pasted. Functions may be pasted anywhere.
- The buzzer does not automatically turn OFF even if the alarm monitor contact turns OFF. The following smart objects are used to turn the buzzer OFF.

Smart object type	Smart object name	Function
Function switches	Buzzer OFF	Buzzer is stopped by the switch being touched.
State control	External buzzer OFF	Buzzer is stopped by PLC bits turning ON.

- The alarm buzzers again when a new alarm monitor contact turns ON even if the alarm has stopped.
- The alarm monitor contacts, the alarm names, and the messages are registered at [Set Alarms] in AP Editor. For details, see the Smart Terminal EST240Z User's Manual Application Preparation Manual No.CP-SP-1088E.

! Handling Precautions

- If the ON time of the alarm contacts is shorter than one alarm monitoring communications cycle, alarm monitoring may not function correctly.

Smart object name	Monitor start/stop					
Type	Alarm monitor					
					Scaling	
Enlarge		Reduce		Reshape	Scaling factor	Text size
○		○		○	Any	Fixed
						Paste coordinates
						Any

■ Function

- This smart object manipulates start/stop of alarm monitoring registered to the alarm monitoring information of the application data.

■ Configuration

● Basic

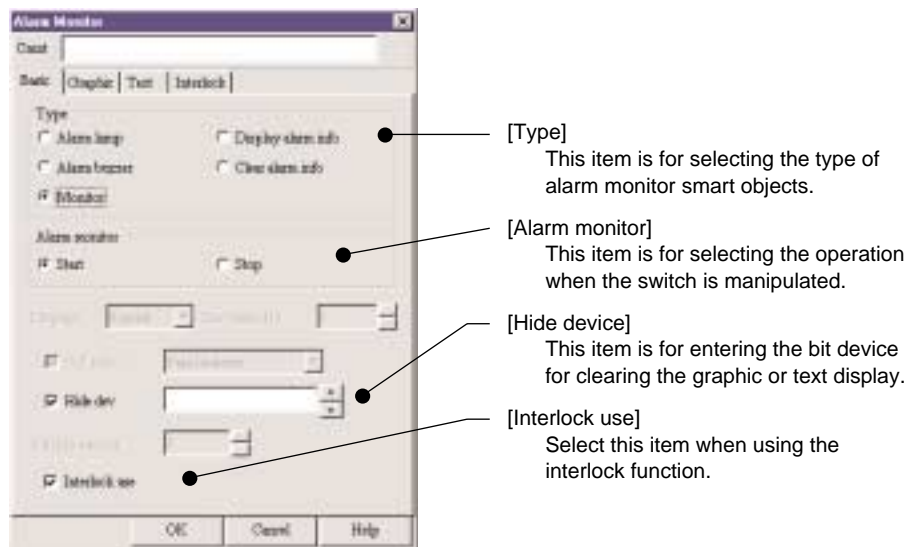

- Alarm monitor
Select operation of the smart object when the switch is manipulated from Start/Stop.

[Start]

Alarm monitoring registered to the alarm monitoring information of the application data is started when a switch is touched.

[Stop]

Alarm monitoring registered to the alarm monitoring information of the application data is stopped when a switch is touched.

● Graphic

Set the OFF/ON Graphic to be displayed on the smart object and the graphic display color.

When Start is selected for alarm monitor, the OFF Graphic setting is displayed while alarm monitoring is stopped, and the ON Graphic setting is displayed while alarms are being monitored.

When Stop is selected for alarm monitor, the ON Graphic setting is displayed while alarm monitoring is stopped, and the OFF Graphic setting is displayed while alarms are being monitored.

- **Text**

Set the display string at OFF/ON to be displayed on the smart object and the display text color.

When Start is selected for alarm monitor, the OFF text setting is displayed while alarm monitoring is stopped, and the ON text setting is displayed while alarms are being monitored.

When Stop is selected for alarm monitor, the ON text setting is displayed while alarm monitoring is stopped, and the OFF text setting is displayed while alarms are being monitored.

- **Interlock**

Set the entry enabled conditions for the switch.

- **Example**

During alarm monitoring

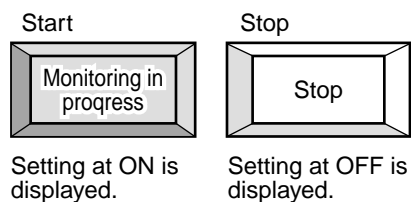

While alarm monitoring is stopped

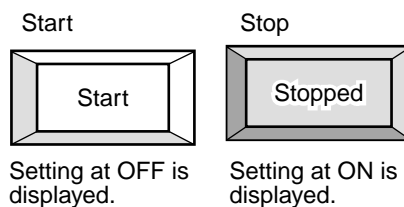

■ Smart Object Parameters

Parameter type	Parameter name	Selection/setting item	Remarks
Basic	Alarm monitor	Select smart object operation at switch input from start/stop.	
	Hide device	Enter the communications channel, the device address, and the bit device.	
	Interlock use	Select when the interlock function is used.	
Graphic	Type	Select general.	
	OFF Graphic	Select the display graphic for when alarm monitoring is stopped.	
	Color when OFF	Select the graphic display color for when alarm monitoring is stopped.	
	Blink when OFF	Select to cause blinking when alarm monitoring is stopped.	
	ON Graphic	Select the display graphic for when alarm monitoring is in progress.	
	Color when ON	Select the graphic display color for when alarm monitoring is in progress.	
Text	Blink when ON	Select to cause blinking when alarm monitoring is in progress.	
	Font size	Select the font size from 8 and 16 dots.	
	V alignment	Select vertical alignment from top/center/bottom.	
	H alignment	Select horizontal alignment from left/center/right.	
	Horizontal scale	Enter the horizontal scale of the string.	1 to 8
	Vertical scale	Enter the vertical scale of the string.	1 to 8
	OFF string	Enter the display string for when alarm monitoring is stopped.	
	OFF color	Select the display text color for when alarm monitoring is stopped.	
	Blink when OFF	Select to cause blinking when alarm monitoring is stopped.	
	ON string	Enter the display string for when alarm monitoring is in progress.	
	ON color	Select the display text color for when alarm monitoring is in progress.	
	Blink when ON	Select to cause blinking when alarm monitoring is in progress.	
Interlock	Bit state	Interlock action according to ON/OFF state of bit device	
	Range	Interlock action according to bit device range	

■ Supplementary Explanation

- Select OFF graphic for the graphic selection. OFF graphic is paired with ON graphic and is automatically selected.
- For details on smart object settings, see “2-2 Main Configuration Items for Smart Objects” (page 2-5).
- The alarm monitor contacts, the alarm names, and the messages are registered at [Set Alarms] in AP Editor. For details, see the Smart Terminal EST240Z User’s Manual Application Preparation Manual No.CP-SP-1088E.

! Handling Precautions

- “User” cannot be selected as the graphic type selection.
- History is monitored regardless of the previous switch state as operation when the EST is turned ON when recording the alarm history.



Smart object name	Summary display [alarm information display]					
Type	Alarm monitor					
	Scaling				Paste coordinates	
	Enlarge	Reduce	Reshape	Scaling factor		Text size
				—	—	Any

■ **Function**

- This smart panel displays the state of occurrence of alarms registered to the alarm monitoring information of the application data.
- The cursor is displayed, and the message for the alarm currently displayed at the cursor position is displayed.
- Up to 100 summaries are stored. When an alarm occurs, that alarm No. and the alarm name are stored in the alarm No. order. When 100 or more alarms simultaneously occur, up to 100 alarms can be stored in the ascending order of alarm No.
- The display can be scrolled by the scroll key.

■ **Configuration**

● **Basic**



[Type]
This item is for selecting the type of alarm monitor smart object.

[Details]
This item is for selecting the display content of the alarm information display.

● **Design**



This sheet is for setting the graphic to be displayed on the smart object and the display color of the graphic.

Set the display text color of the string to be displayed on the smart object.

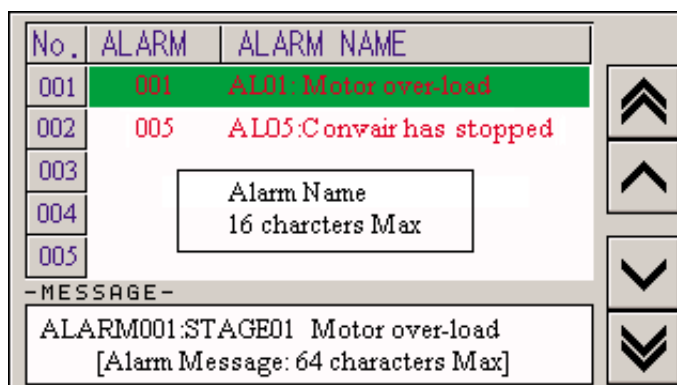
■ Example



- **Alarm No.**
Displays the No. of the currently occurring alarm currently registered to the history information.
- **Alarm name**
Displays the name of the alarm currently registered to the history information of the currently occurring alarm using up to 16 1-byte characters.
- **Message**
Displays the alarm messages currently registered to the history information of the alarm No. selected at the cursor display using up to 64 1-byte characters.

  : Scrolls the cursor display one cursor at a time.

  : Scrolls the display alarms five alarms at a time.

■ Smart Object Parameters

Tab name	Parameter name	Selection/setting item	Remarks
Design	Graphic type	Select general.	
	Graphic	Select the display graphic.	
	Fill color	Select the graphic display color.	
	Alarm No.	Select the display text color of the alarm No.	
	Alarm name	Select the display text color of the alarm name.	
	Message	Select the display text color of the alarm message.	
	Cursor	Select the display color of the cursor.	

■ Supplementary Explanation

- For details on smart object settings, see “2-2 Main Configuration Items for Smart Objects” (page 2-5).
- The alarm monitor contacts, the alarm names, and the messages are registered at [Set Alarms] in AP Editor. For details, see the Smart Terminal EST240Z User’s Manual Application Preparation Manual No. CP-SP-1088E.

! Handling Precautions

- If the ON time of the alarm contacts is shorter than one alarm monitoring communications cycle, alarm monitoring may not function correctly.
- “User” cannot be selected as the graphic type selection.

Smart object name	History display [alarm information display]					
Type	Alarm monitor					
	Scaling				Paste coordinates	
	Enlarge	Reduce	Reshape	Scaling factor		Text size
				—	—	Any

■ **Function**

- This smart panel displays the state of occurrence/recovery of alarms registered to the alarm monitoring information of the application data.
- Up to 400 history records are stored. When an alarm occurs, the name of the alarm, date of occurrence (Month/Date) and time of occurrence (Hour/Minute) are displayed at the alarm occurrence display color. When an alarm is recovered, the date of recovery (Month/Date) and time of recovery (Hour/Minute) are displayed at the alarm recovery display color.
- The display can be scrolled by the scroll key.

■ **Configuration**

● **Basic**

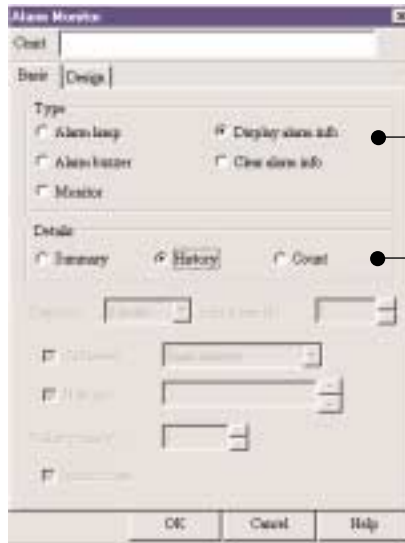

[Type]
This item is for selecting the type of alarm monitor smart object.

[Details]
This item is for selecting the display content of the alarm information display.

● **Design**

This sheet is for setting the graphic to be displayed on the smart object and the display color of the graphic.

Set the display text color of the string to be displayed on the smart object.



■ Example



No.	ALARM	OCCUR	RECOVER
	ALARM-001	09 - 11 12 : 15	09 - 11 12 : 32
	ALARM-005	09 - 12 18 : 23	- : -
		- : -	- : -
		- : -	- : -
		- : -	- : -

Alarm recovery text color display

Alarm occurrence text color display

- Alarm
Displays the No. of the alarm that occurred by the alarm name currently registered to the history information.
- Occur
Displays the date/time (month/day, hours/minutes) that the alarm occurred.
- Recover
Displays the date/time (month/day, hours/minutes) that the alarm was recovered.

  : Each touch of these switches scrolls the history display by one history at a time.

  : Each touch of these switches scrolls the history display by five histories at a time.

  : The keys scroll the display to the oldest/latest history record.

■ Smart Object Parameters

Tab name	Parameter name	Selection/setting item	Remarks
Design	Type	Select general.	
	No.	Select the display graphic.	
	Color	Select the graphic display color.	
	Alarm ON	Select the display text color for alarm occurred states.	
	Alarm OFF	Select the display text color for alarm restored states.	

■ Supplementary Explanation

- The history display No. shows the order in which alarms occurred. (No.001 indicates the oldest alarm.)
- The initial display shows the latest record.
- To create an alarm history, [Record History] must be selected at [Set Alarms] in AP Editor.
- If the number of records in the alarm history exceeds 400 when “Ring” is set as the history recording method in the alarm history settings, the records are overwritten in order from the oldest record onwards. When “Fixed” is set as the history recording method, sampling of the alarm history is stopped when the number of records in the alarm history reaches 400. To resume sampling in this case, “Clear alarm information” must be executed.
- For details on smart object settings, see “2-2 Main Configuration Items for Smart Objects” (page 2-5).
- The alarm monitor contacts, the alarm names, and the messages are registered at [Set Alarms] in AP Editor. For details, see the Smart Terminal EST240Z User’s Manual Application Preparation Manual No.CP-SP-1088E.

! Handling Precautions

- If the ON time of the alarm contacts is shorter than one alarm monitoring communications cycle, alarm monitoring may not function correctly.
- “User” cannot be selected as the graphic type selection.
- Past history data still remains after the application data is downloaded. To clear the history data, touch the alarm information clear switch.

Smart object name	Number of occurrence display [alarm information display]					
Type	Alarm monitor					
	Scaling				Paste coordinates	
	Enlarge	Reduce	Reshape	Scaling factor		Text size
				—	—	Any

■ **Function**

- This smart object displays the number of times that alarms registered to the alarm monitoring information of the application data have occurred.
- The number of times that alarms No.1 to 512 have occurred is displayed.
- The display can be scrolled by the scroll key.

■ **Configuration**

● **Basic**



[Type]
This item is for selecting the type of alarm monitor smart object.

[Details]
This item is for selecting the display content of the alarm information display.



● **Design**



This sheet is for setting the graphic to be displayed on the smart object and the display color of the graphic.

Set the display text color of the string to be displayed on the smart object.



■ Example



ALARM	ALARM NAME	NUMBER
001	ALARM 001	1
002	ALARM 002	10
003	ALARM 003	7
004	ALARM 004	21
005	ALARM 005	0







- Alarm
Displays the alarm No.
- Alarm name
Displays the name of the alarm currently registered to the history information.
- Number
Displays the number of times that alarms have occurred.

  : Each touch of these switches scrolls the alarm No. display by one alarm at a time.

  : Each touch of these switches scrolls the alarm No. display by five alarms at a time.

  : Each touch of these switches scrolls the alarm No. display by 100 alarms.

■ Smart Object Parameters

Tab name	Parameter name	Selection/setting item	Remarks
Design	Type	Select general.	
	No.	Select the display graphic.	
	Color	Select the graphic display color.	
	Alarm No.	Select the display text color of the alarm No.	
	Name	Select the display text color of the alarm name.	
	Count	Select the display text color for the number of alarm occurrences.	

■ Supplementary Explanation

- To create an alarm history, [Record History] must be selected at [Set Alarms] in AP Editor.
- For details on smart object settings, see “2-2 Main Configuration Items for Smart Objects” (page 2-5).
- The alarm monitor contacts, the alarm names, and the messages are registered at [Set Alarms] in AP Editor. For details, see the Smart Terminal EST240Z User’s Manual Application Preparation Manual No.CP-SP-1088E.

! Handling Precautions

- If the ON time of the alarm contacts is shorter than one alarm monitoring communications cycle, alarm monitoring may not function correctly.
- When the number of occurred alarms exceeds 65535, counting beyond 65535 is not performed.
- “User” cannot be selected as the graphic type selection.
- Past history data still remains after the application data is downloaded. To clear the history data, touch the alarm information clear switch.

Smart object name	Alarm information clear				
Type	Alarm monitor				
Scaling					Paste coordinates
Enlarge	Reduce	Reshape	Scaling factor	Text size	
<input type="radio"/>	<input type="radio"/>	<input type="radio"/>	Any	Fixed	Any

Function

- This smart object clears the alarm information (summary/history/number of occurrences) sampled according to the alarm monitoring history of the application data.
- Inadvertent clearing of data can be prevented by setting an entry wait time.

Configuration

● **Basic**



[Type]
This item is for selecting the type of alarm monitor smart object.

[Validity time(s)]
This item is for setting the touch wait time of the switch.

[Interlock use]
Select this item when using the interlock function.

- **Validity time(s)**
Set the touch wait time of the switch in seconds.
If the switch is not held down for the time set here, the data is not cleared.

● **Graphic**

This sheet is for setting the graphic to be displayed on the smart object and the display color of the graphic.

● **Text**

This sheet is for setting the string to be displayed on the smart object and the display text color.

● **Interlock**

This sheet is for setting the entry enabled conditions for the switch.

■ Example

Validity time = 10

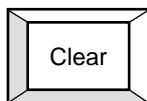

Continuously touch
switch for 10 seconds.

Clear processing is executed after 10 seconds elapses.

■ Smart Object Parameters

Tab name	Parameter name	Selection/setting item	Remarks
Basic	Validity time(s)	Enter the switch input validity time.	0 to 60s
	Interlock use	Select when the interlock function is used.	
Graphic	Type	Select general.	
	No.	Select the display graphic.	
	Color	Select the display color of the graphic.	
Text	Font size	Select the font size from 8 and 16 dots.	
	V alignment	Select vertical alignment from top/center/bottom.	
	H alignment	Select horizontal alignment from left/center/right.	
	Horizontal scale	Enter the horizontal scale of the string.	1 to 8
	Vertical scale	Enter the vertical scale of the string.	1 to 8
	String	Enter the display text.	
	Text color	Enter the display text color.	
Interlock	Bit state	Interlock action according to ON/OFF state of bit device	
	Range	Interlock action according to bit device range	

■ Supplementary Explanation

- For details on smart object settings, see “2-2 Main Configuration Items for Smart Objects” (page 2-5).
- The alarm monitor contacts, the alarm names, and the messages are registered at [Set Alarms] in AP Editor. For details, see the Smart Terminal EST240Z User’s Manual Application Preparation Manual No.CP-SP-1088E.

! Handling Precautions

- “User” cannot be selected as the graphic type selection.



3 - 12 Clocks

Smart object name	Digital clock				
Type	Clock				
Scaling					Paste coordinates
Enlarge	Reduce	Reshape	Scaling factor	Text size	
○	○		Integer multiple	Interlocked	Any

■ Function

- This smart object displays the EST internal clock.

■ Configuration

● Basic

The screenshot shows the 'Clock' configuration dialog box with the following settings and callouts:

- [Type]**: This item is for selecting the type of clock smart object. (Points to the 'Type' section with radio buttons for Digital clock, Digital calendar, Analogue clock, and Ext clock adjust.)
- [Display method]**: This item is for selecting the time display method. (Points to the '24 hours' dropdown menu.)
- [Type]**: This item is for selecting the graphic type to be displayed. (Points to the 'Type' dropdown menu set to 'Univ'.)
- [No.]**: This item is for selecting the graphic to be displayed. (Points to the 'No.' spinner control set to '10176'.)
- [Color]**: This item is for selecting the display color of the graphic. (Points to the 'Color' selection area.)
- [Text color]**: This item is for selecting the display text color for the time. (Points to the 'Text color' selection area.)

- Display method
Select the time display method from 24-hour display/12-hour display.

■ Example

[24-hour display]

3 hours, 45 minutes, 8 seconds p.m.

15 : 45 : 08

[12-hour display]

3 hours, 45 minutes, 8 seconds p.m.

3 : 45 : 08 pm

■ Smart Object Parameters

Tab name	Parameter name	Selection/setting item	Remarks
Basic	Display method	Select from 24hr display/12hr display.	
	Type	Select general.	
	No.	Select the display graphic.	
	Color	Select the display color of the graphic.	
	Text color	Select the display text color of the time.	

■ Supplementary Explanation

- The following smart objects are used for correcting the time.

Smart object type	Smart object name	Function
Function switches	Clock setting call	Corrects the internal clock.
Clock	External clock adjustment	Adjusts the internal clock to "0" by external bits turning ON.

! Handling Precautions

- Only "General" can be selected for the graphic type. "User" cannot be selected.

Smart object name	Analog clock				
Type	Clock				
Scaling					Paste coordinates
Enlarge	Reduce	Reshape	Scaling factor	Text size	
○	○		Integer multiple	Interlocked	Any

■ **Function**

- This smart object displays the EST internal clock in analog format.

■ **Configuration**

● **Basic**

The screenshot shows the 'Clock' configuration dialog box with the following settings and callouts:

- [Type]**: Points to the 'Type' section where 'Analog clock' is selected.
- [Second hand]**: Points to the 'Second hand' checkbox, which is checked.
- [Type]**: Points to the 'Type' dropdown menu, currently set to 'Univ'.
- [No.]**: Points to the 'No.' field, currently set to '30001'.
- [Color]**: Points to the 'Color' field, currently set to red.
- [Long/Short, Seconds]**: Points to the 'Long/Short' and 'Seconds' color selection fields.

■ **Example**

10 hours, 08 minutes, 42 seconds:



■ **Smart Object Parameters**

Tab name	Parameter name	Selection/setting item	Remarks
Basic	Display method	Select from 24hr display/12hr display.	
	Type	Select general.	
	No.	Select the display graphic.	
	Long/Short	Select the color of the long/short hands.	
	Seconds	Select the color of the second hand.	
	Second hand	Select when displaying the second hand in the time display.	

■ Supplementary Explanation

- The following smart objects are used for correcting the time.

Smart object type	Smart object name	Function
Function switches	Clock setting call	Corrects the internal clock.
Clock	External clock adjustment	Adjusts the internal clock second time to "0" by external bits turning ON.

! Handling Precautions

- Only "General" can be selected for the graphic type. "User" cannot be selected.

Smart object name	Digital calendar				
Type	Clock				
Scaling					Paste coordinates
Enlarge	Reduce	Reshape	Scaling factor	Text size	
○	○		Integer multiple	Interlocked	Any

■ **Function**

- This smart object displays the date (Month/Day/Year) and day of the week in digital format.

■ **Configuration**

● **Basic**

The screenshot shows the 'Clock' configuration dialog box with the following settings and callouts:

- Type:** A radio button group where 'Digital calendar' is selected. Callout: [Type] This item is for selecting the type of clock smart object.
- Graphic Type:** A dropdown menu set to 'Univ.'. Callout: [Type] This item is for selecting the graphic type to be displayed.
- No.:** A numeric spinner set to '10001'. Callout: [No.] This item is for selecting the graphic to be displayed.
- Color:** A color selection box. Callout: [Color] This item is for selecting the display color of the graphic.
- Text color:** A color selection box. Callout: [Text color] This item is for selecting the display text color of the calendar.

■ **Example**

November 26 (Sunday) 2000:

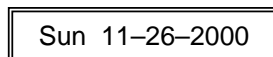

■ Smart Object Parameters

Tab name	Parameter name	Selection/setting item	Remarks
Basic	Type	Select general.	
	No.	Select the display graphic.	
	Color	Select the display color of the graphic.	
	Text color	Select the display text color of the calendar.	

■ Supplementary Explanation

- The following smart objects are used to change Year/Month/Date.

Smart object type	Smart object name	Function
Function switches	Clock setting call	Corrects the internal clock.

! Handling Precautions

- Only “General” can be selected for the graphic type. “User” cannot be selected.

■ Smart Object Parameters

Tab name	Parameter name	Selection/setting item	Remarks
Basic	Clock adjustment device	Enter the communications channel, the device address, and the bit device.	

■ Supplementary Explanation

- This is a transparent smart object, and may be pasted anywhere.

! Handling Precautions

- Enter the bit device on the PLC for the clock adjustment device. Do not enter word devices such as registers.
- Execute setting of the bits on the clock adjustment device by one-shot instructions.

[Ladder circuit example]

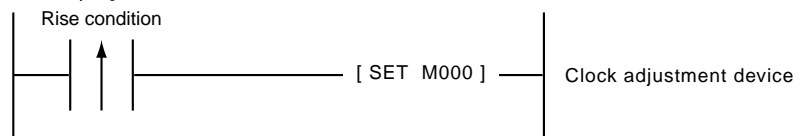

3 - 13 State Control

Smart object name	External backlight control				
Type	State control				
Scaling					Paste coordinates
Enlarge	Reduce	Reshape	Scaling factor	Text size	
			—	—	Any

■ Function

- This smart object can turn the EST backlight ON and OFF from the PLC.

■ Configuration

● Basic

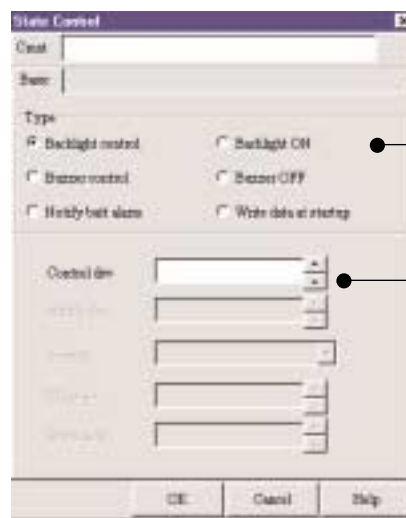

[Target]
This item is for selecting the type of external control smart object.

[Control device]
This item is for entering the bit device for controlling the backlight.

- Control device
EST backlight ON/OFF is controlled by the ON/OFF setting of the control device.

Control device	Backlight state
OFF (0)	Light ON
ON (1)	Light OFF

■ Example

Control device = M000

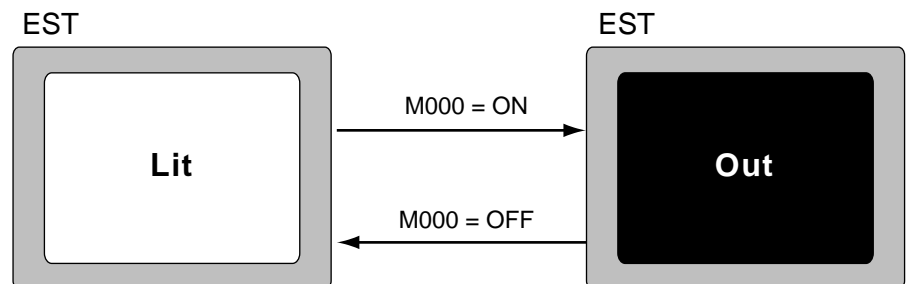

■ Smart Object Parameters

Tab name	Parameter name	Selection/setting item	Remarks
Basic	Control device	Enter the communications channel, the device address, and the bit device.	

■ Supplementary Explanation

- When this smart object is pasted to the panel used as background panel, the backlight can be controlled on the PLC at all times.
- The backlight lights/goes out when the state of the control device changes.
- This is a transparent smart object, and may be pasted anywhere.

! Handling Precautions

- Ensure ON/OFF times on the control device of at least twice the maximum EST scan time.
- A backlight that has been turned OFF with this smart object is not turned ON by touching the screen.
- Enter the bit device on the PLC as the Control device. Do not enter word devices such as registers.

Smart object name	External backlight ON					
Type	State control					
	Scaling				Paste coordinates	
	Enlarge	Reduce	Reshape	Scaling factor		Text size
				—	—	Any

■ **Function**

- This smart object forcibly turns the EST backlight ON from the PLC.
- This smart object lights the backlight when the control device is activated.

■ **Configuration**

- **Basic**

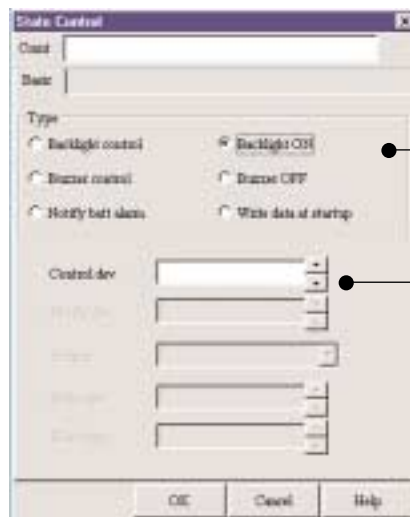

[Target]
This item is for selecting the type of external control smart object.

[Control device]
This item is for entering the bit device for lighting the backlight.

- **Control device**
The EST backlight is forcibly lit when the control device is activated.
The EST turns the control device OFF when the backlight is lit.

■ **Example**

Control device = M000

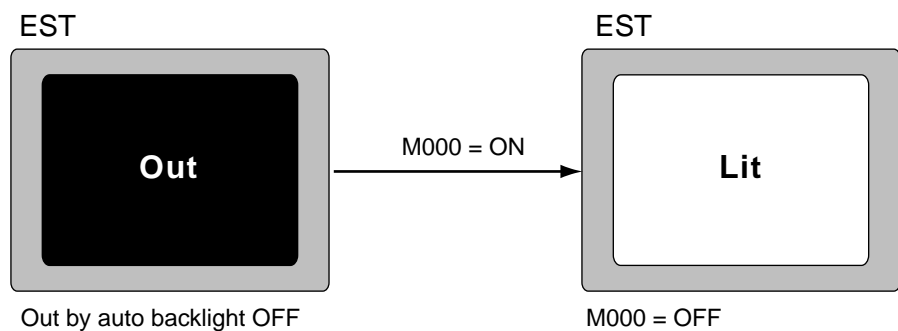

■ **Smart Object Parameters**

Tab name	Parameter name	Selection/setting item	Remarks
Basic	Control device	Enter the communications channel, the device address, and the bit device.	

■ **Supplementary Explanation**

- This smart object can forcibly light the backlight even when the backlight has been turned OFF with the auto backlight OFF function. The auto backlight OFF function is set at [Setting Information] - [Basic Settings] in AP Editor. For details, see the Smart Terminal EST240Z User's Manual Application Preparation Manual No.CP-SP-1088E.
- Time monitoring of the auto backlight OFF function is continued even if the backlight is turned ON by this smart object. The backlight goes out when the set time has elapsed.
- This is a transparent smart object, and may be pasted anywhere.

! **Handling Precautions**

- Enter the bit device on the PLC as the Control device. Do not enter word devices such as registers.
- Execute setting of the bits on the control device by one-shot instructions.

[Ladder circuit example]

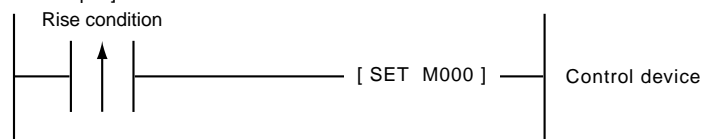

Smart object name	External buzzer control					
Type	State control					
	Scaling				Paste coordinates	
	Enlarge	Reduce	Reshape	Scaling factor		Text size
				—	—	Any

■ **Function**

- This smart object enables the EST buzzer to be turned ON and OFF from the PLC.
- Buzzer is turned ON when the control device is activated, and turned OFF when the control device is deactivated.

■ **Configuration**

- **Basic**

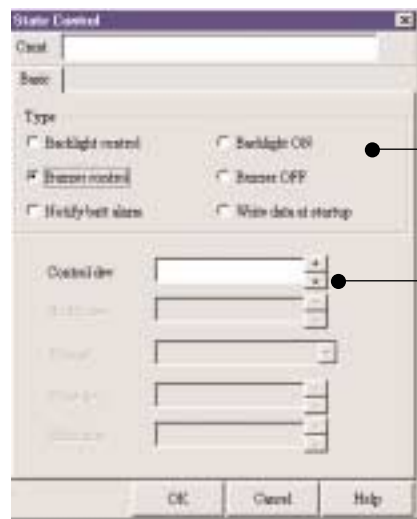

[Target]

This item is for selecting the type of external control smart object.

[Control device]

This item is for entering the bit device for controlling the buzzer.

■ **Example**

Control device = M000

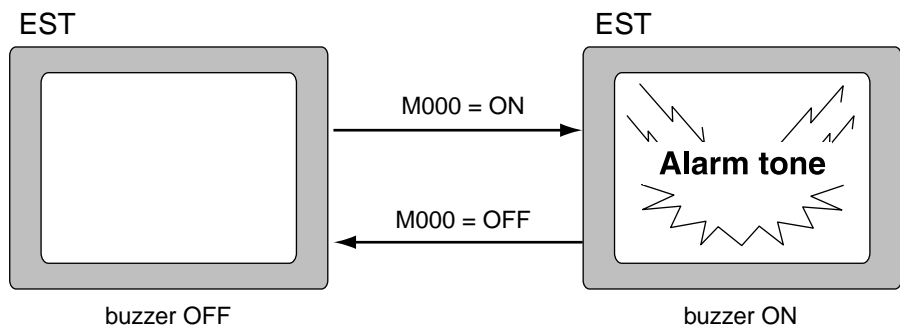

■ Smart Object Parameters

Tab name	Parameter name	Selection/setting item	Remarks
Basic	Control device	Enter the communications channel, the device address, and the bit device.	

■ Supplementary Explanation

- When this smart object is pasted to the panel used as background panel, the buzzer can be controlled on the PLC at all times.
- This is a transparent smart object, and may be pasted anywhere.

! Handling Precautions

- Ensure ON/OFF times on the control device of at least twice the maximum EST scan time.
- Enter the bit device on the PLC as the Control device. Do not enter word devices such as registers.

Smart object name	External buzzer OFF					
Type	State control					
	Scaling				Paste coordinates	
	Enlarge	Reduce	Reshape	Scaling factor		Text size
				—	—	Any

■ **Function**

- This smart object forcibly turns the EST buzzer OFF from the PLC.
- This smart object turns the buzzer OFF when the control device is activated.

■ **Configuration**

- **Basic**

[Target]
This item is for selecting the type of external control smart object.

[Control device]
This item is for entering the bit device for turning the buzzer OFF.

- **Control device**
The EST buzzer is forcibly turned OFF when the control device is activated.
The EST turns the control device OFF when the buzzer is turned OFF.

■ **Example**

Control device = M000

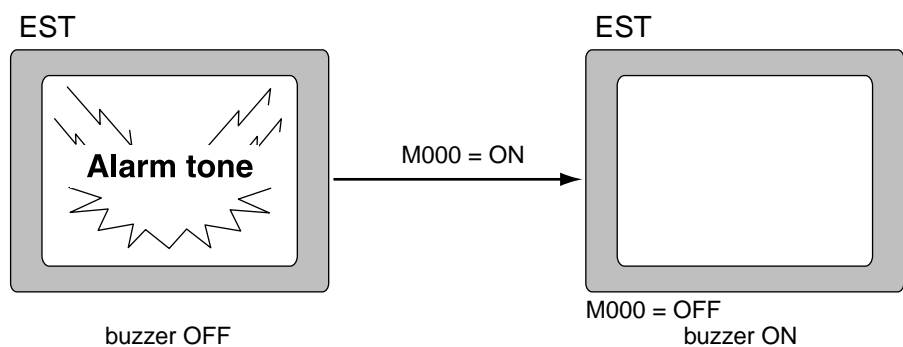

■ **Smart Object Parameters**

Tab name	Parameter name	Selection/setting item	Remarks
Basic	Control device	Enter the communications channel, the device address, and the bit device.	

■ **Supplementary Explanation**

- When this smart object is pasted to the panel used as background panel, the buzzer can be turned OFF on the PLC at all times.
- This is a transparent smart object, and may be pasted anywhere.

❗ **Handling Precautions**

- Enter the bit device on the PLC as the Control device. Do not enter word devices such as registers.
- Execute setting of the bits on the control device by one-shot instructions.

[Ladder circuit example]

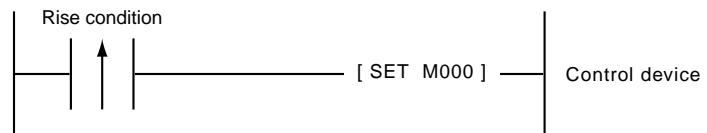

Smart object name	Battery alarm notification				
Type	State control				
Scaling					Paste coordinates
Enlarge	Reduce	Reshape	Scaling factor	Text size	
			—	—	Any

■ **Function**

- This smart object turns the notify device on the PLC ON when a battery alarm occurs on the EST.

■ **Configuration**

- **Basic**

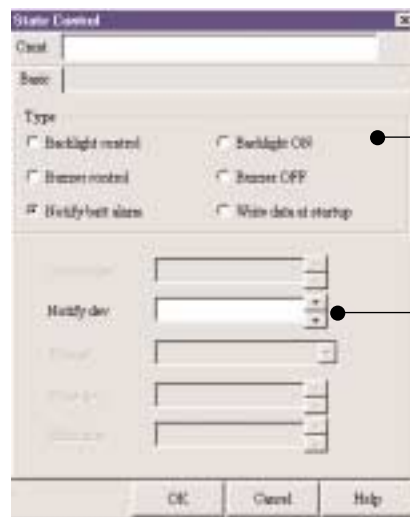

[Target]
This item is for selecting the type of external control smart object.

[Notify device]
This item is for entering the bit device for notifying occurrence of the battery alarm.

- **Notify device**

Sets the notify device ON at approximately every 10 seconds while the battery alarm state is occurring.

The notify device is not reset to OFF even if the EST battery alarm state is recovered.

■ **Example**

Notify device = M000

EST

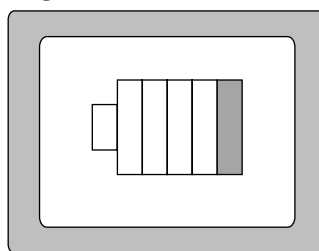

M000 is set to ON at approx. 10 seconds intervals

M000 = ON

Battery alarm occurring

■ Smart Object Parameters

Tab name	Parameter name	Selection/setting item	Remarks
Basic	Control device	Enter the communications channel, the device address, and the bit device.	

■ Supplementary Explanation

- When this smart object is pasted to the panel used as background panel, the EST battery alarm can be monitored at all times.
- This is a transparent smart object, and may be pasted anywhere.
- For details on how to replace the battery, see the Smart Terminal EST240Z User's Manual Installation Manual Manual No.CP-SP-1065E.

! Handling Precautions

- Enter the bit device on the PLC as the Notify device. Do not enter word devices such as registers.

Smart object name	Data write when opening the panel					
Type	State control					
	Scaling				Paste coordinates	
	Enlarge	Reduce	Reshape	Scaling factor		Text size
				—	—	Any

■ **Function**

- This smart object writes data set at Write data to the Write device on the PLC when panel startup is activated.

■ **Configuration**

- **Basic**

The screenshot shows the 'State Control' configuration window. It has a 'Basic' tab and a 'Type' section with radio buttons for 'Backlight control', 'Button control', and 'Start/stop alarm'. There are also checkboxes for 'Backlight ON', 'Button OFF', and 'Write data at startup'. Below this are fields for 'Format' (set to 'Signal binary'), 'Write dev' (empty), and 'Write data' (set to '0'). Callouts point to these fields with the following descriptions:

- [Target]**: This item is for selecting the type of external control smart object.
- [Format]**: This item is for selecting the data format of the write data.
- [Write device]**: This item is for entering the word device to which the data is to be written when the panel is started up.
- [Write data]**: This item is for entering the write data.

■ **Example**

Write device = D000, write data = 100

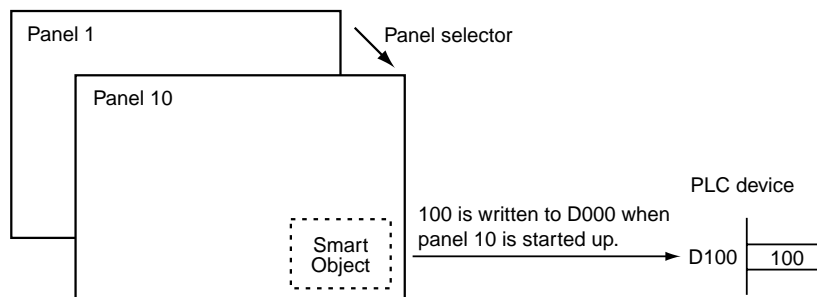

■ Smart Object Parameters

Tab name	Parameter name	Selection/setting item	Remarks
Basic	Format	Select the write data format from unsigned binary/signed binary/Hex/BCD.	
	Write device	Enter the communications channel, the device address, and the word device.	
	Write data	Enter the write data.	Unsigned binary: 0 to 65535 Signed binary: -32768 to +32767 Hex/BCD: 0 to FFFF

■ Supplementary Explanation

- The operating panel on the EST can be confirmed by setting the write data to the same data as the panel No. and pasting this smart object to each panel.
- This is a transparent smart object, and may be pasted anywhere.

! Handling Precautions

- Be sure to enter a multiple of 16 when entering the bit device to the write device.

Chapter 4. INSTRUMENTATION SMART OBJECTS

4 - 1 PID controller

Smart object name	SDC10				
Type	PID controller				
Scaling					Paste coordinates
Enlarge	Reduce	Reshape	Scaling factor	Text size	
			—	—	Any

Function

- This smart object enables monitoring of the run state of the SDC10.
- The SP value can also be changed.

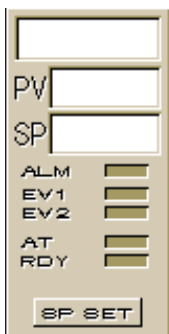

- Name: Up to eight 1-byte characters can be entered.
- PV: This displays the PV (process variable) value.
- SP: This displays the SP (set point) value.
- ALM: This blinks when an alarm occurs.
- EV1: This lights when EV1 is ON.
- EV2: This lights when EV2 is ON.
- AT: This blinks during auto-tuning.
- RDY: This lights when the SDC10 is in the Ready mode.
- SP SET: This button causes a numeric keypad to pop up so that the SP value can be changed.

Configuration

Basic

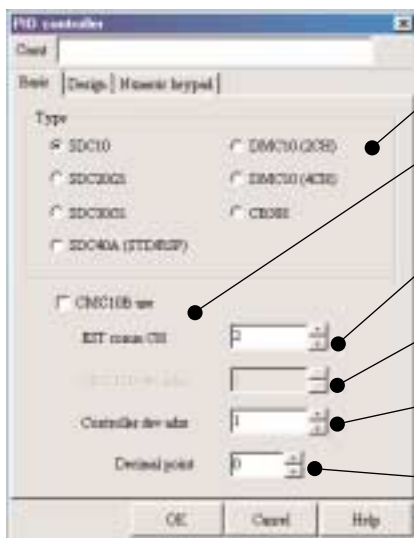

- [Type] This item is for selecting the IMEC type.
- [CMC10B use] Select this item when connecting the SDC10 via the CMC10B.
- [EST communications channel] This item is for entering the communications channel on the EST.
- [CMC10B device address] This item is for entering the device address of the CMC10B.
- [Controller device address] This item is for entering the device address of the SDC10.
- [Decimal point] This item is for entering the decimal point display position of the SP and PV values.

- CMC10B use
Select this item when the SDC10 is to be connected to the EST via the CMC10B.

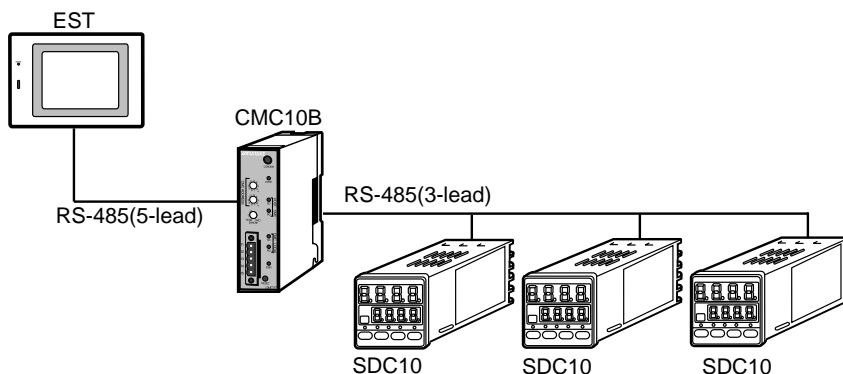

● **Design**

This sheet is for setting the graphic to be displayed on the smart object and the display color of the graphic.

Set the display text color and name of the PV and SP values to be displayed on the smart object.

● **Numeric keypad**

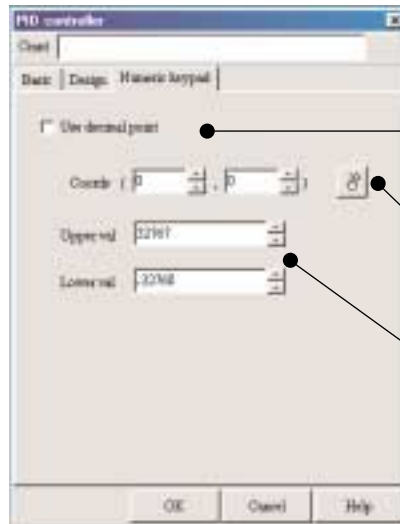

- [Use decimal point]
Select this item when a numeric keypad panel with decimal point entry is to be used.
- [Coordinates]
This item is for entering the call coordinates of the numeric keypad panel.
- [Upper/lower value]
This item is for entering the data entry upper/lower limit values on the numeric keypad panel.

- **Use decimal point**
Call the numeric keypad panel having a decimal point entry function.
For details on the numeric keypad panel, see “5-2 Numeric Keypad” (page 5-4).
- **Upper/lower value**
Enter the valid range of the data when the data is set on the numeric keypad panel.
When the data entered on the numeric keypad panel exceeds the valid range when the [ENT] key is touched, an error occurs, and the data is not written to SDC10. At this time, a short, high-pitched alarm buzzers, and the set data is cleared to “0”.

[Data entry range]
Upper value ≥ Setting data ≥ Lower value

■ Smart Object Parameters

Tag name	Parameter name	Selection/setting item	Remarks
Basic	CMC10B use	Select when a SDC is connected via the CMC10B.	
	EST communications channel	Enter the communications channel on the EST.	1 to 4
	CMC10B device address	Enter the device address of the CMC10B.	1 to 127
	Controller device address	Enter the device address of the SDC10.	1 to 127
	Decimal point	Enter the decimal point display position of PV and SP.	0 to 1
Design	Type	Select the graphic type.	
	No.	Select the display graphic.	
	Fill color	Select the display color of the graphic.	
	PV color	Select the numeric display color of the PV.	
	SP color	Select the numeric display color of the SP.	
	Name	Enter the name.	
Numeric keypad	Text color	Enter the name text color.	
	Use decimal point	Select when using a numeric keypad panel with decimal point input.	
	Coordinates	Enter the call coordinates of the numeric keypad panel.	
	Input upper value	Enter the input data upper limit value on the numeric keypad panel.	
	Input lower value	Enter the input data lower limit value on the numeric keypad panel.	

■ Supplementary Explanation

- Changes to the SP value are executed on the current SP value of the SDC10. The “current SP value” refers to the SP value of the currently selected SP set. For example, when the SP value is changed while SP1 is selected, SP1 will be rewritten.
- For details on smart object settings, see “2-2 Main Configuration Items for Smart Objects” (page 2-5).

! Handling Precautions

- Set the communications channel to which the IMEC is to be connected to “Yamatake CPL general host link.”

Smart object name	SDC20/21				
Type	PID controller				
Scaling					Paste coordinates
Enlarge	Reduce	Reshape	Scaling factor	Text size	
			—	—	Any

■ Function

- This smart object enables monitoring of the run state of the SDC20/21.
- The SP value can also be changed.

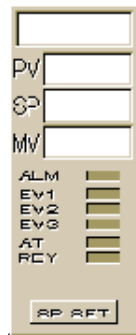

- PV: This displays the PV (process variable) value.
- SP: This displays the SP (set point) value.
- MV: This displays the MV (manipulated variable) value.
- ALM: This blinks when an alarm occurs.
- EV1: This lights when EV1 is ON.
- EV2: This lights when EV2 is ON.
- EV3: This lights when EV3 is ON.
- AT: This blinks during auto-tuning.
- RDY: This lights when the SDC10 is in the Ready mode.
- SP SET: This button causes a numeric keypad to pop up so that the SP value can be changed.

■ Configuration

● Basic

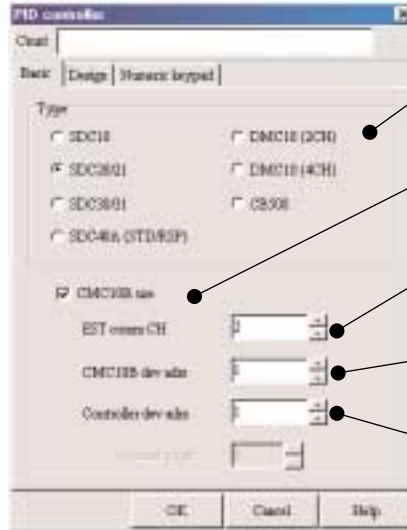

- [Type] This item is for selecting the IMEC type.
- [CMC10B use] Select this item when connecting the SDC20/21 via the CMC10B.
- [EST communications channel] This item is for entering the communications channel on the EST.
- [CMC10B device address] This item is for entering the device address of the CMC10B.
- [Controller device address] This item is for entering the device address of the SDC20/21.

- CMC10B use Select this item when the SDC20/21 is to be connected to the EST via the CMC10B.

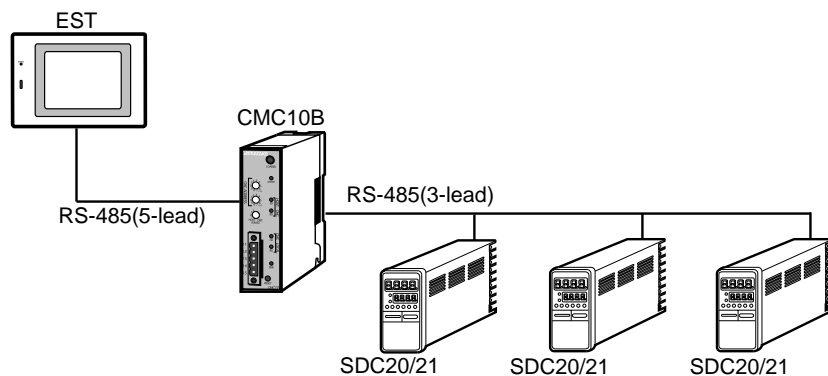

● Design

This sheet is for setting the graphic to be displayed on the smart object and the display color of the graphic.

Set the display text color and name of the PV, SP and MV values to be displayed on the smart object.

● Numeric keypad

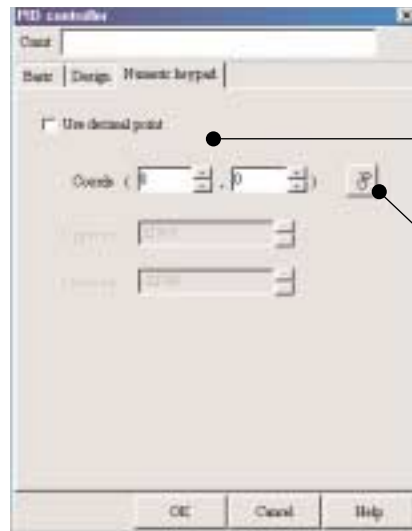

[Use decimal point]

Select this item when a numeric keypad panel with decimal point entry is to be used.

[Coordinates]

This item is for entering the call coordinates of the numeric keypad panel.

- Use decimal point

Call the numeric keypad panel having a decimal point entry function.

For details on the numeric keypad panel, see “5-2 Numeric Keypad” (page 5-4).

■ Smart Object Parameters

Tag name	Parameter name	Selection/setting item	Remarks
Basic	CMC10B use	Select when a SDC is connected via the CMC10B.	
	EST communications channel	Enter the communications channel on the EST.	1 to 4
	CMC10B device address	Enter the device address of the CMC10B.	1 to 127
	Controller device address	Enter the device address of the SDC20/21.	1 to 127
Design	Graphic type	Select the graphic type.	
	No.	Select the display graphic.	
	Fill color	Select the display color of the graphic.	
	PV color	Select the numeric display color of the PV.	
	SP color	Select the numeric display color of the SP.	
	MV color	Select the numeric value display color of MV.	
	Name	Enter the name.	
Numeric keypad	Text color	Enter the name text color.	
	Use decimal point	Select when using a numeric keypad panel with decimal point input.	
	Coordinates	Enter the call coordinates of the numeric keypad panel.	

■ Supplementary Explanation

- Changes to the SP value are executed on the current SP value of the SDC20/21. The “current SP value” refers to the SP value of the currently selected SP set. For example, when the SP value is changed while SP1 is selected, SP1 will be rewritten.
- The settable range of the SP value is the lower SP limit to the upper SP limit in the setup on the SDC20/21.
- For details on smart object settings, see “2-2 Main Configuration Items for Smart Objects” (page 2-5).

! Handling Precautions

- Set the communications channel to which the IMEC is to be connected to “Yamatake CPL general host link.”
- The panel may not function properly when the following items on the SDC20/21 are changed while a panel to which this smart object is pasted is activated. The panel will function properly by restarting the panel after the change has been made.
 - C02: Temperature unit
 - C04: Input range
 - C05: Decimal point position
 - C09: Lower SP limit
 - C10: Upper SP limit
- When the SP lamp is operating, the SP value in the lamp cannot be displayed. The SP value is displayed when the final SP value is reached.

Smart object name	SDC30/31				
Type	PID controller				
	Scaling				Paste coordinates
	Enlarge	Reduce	Reshape	Scaling factor	Text size
				—	—
					Any

■ Function

- This smart object enables monitoring of the run state of the SDC30/31.
- The SP value can also be changed.



- PV: This displays the PV (process variable) value.
- SP: This displays the SP (set point) value.
- MV: This displays the MV (manipulated variable) value.
- ALM: This blinks when an alarm occurs.
- EV1: This lights when EV1 is ON.
- EV2: This lights when EV2 is ON.
- AT: This blinks during auto-tuning.
- RDY: This lights when the SDC30/31 is in the Ready mode.
- REM: This lights when the SDC30/31 is in the Remote SP mode.
- MAN: This lights when the SDC30/31 is in the Manual mode.
- SP SET: This button causes a numeric keypad to pop up so that the SP value can be changed.

■ Configuration

● Basic

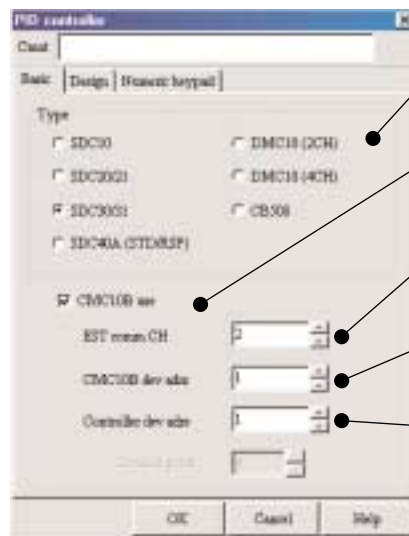

- [Type] This item is for selecting the IMEC type.
- [CMC10B use] Select this item when connecting the SDC30/31 via the CMC10B.
- [EST communications channel] This item is for entering the communications channel on the EST.
- [CMC10B device address] This item is for entering the device address of the CMC10B.
- [Controller device address] This item is for entering the device address of the SDC30/31.

• CMC10B use

Select this item when the SDC30/31 is to be connected to the EST via the CMC10B.

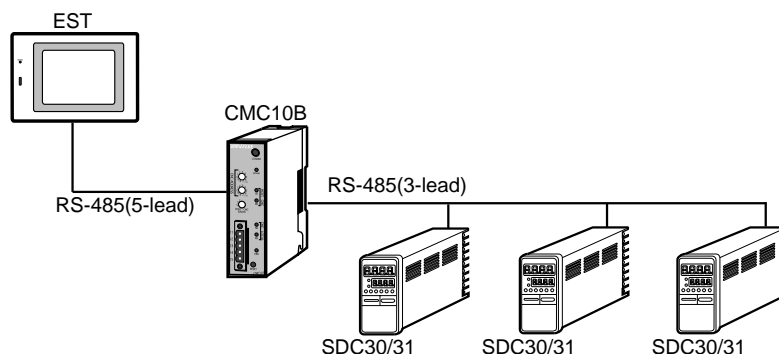

● Design

This sheet is for setting the graphic to be displayed on the smart object and the display color of the graphic.

Set the display text color and name of the PV, SP and MV values to be displayed on the smart object.

● Numeric keypad

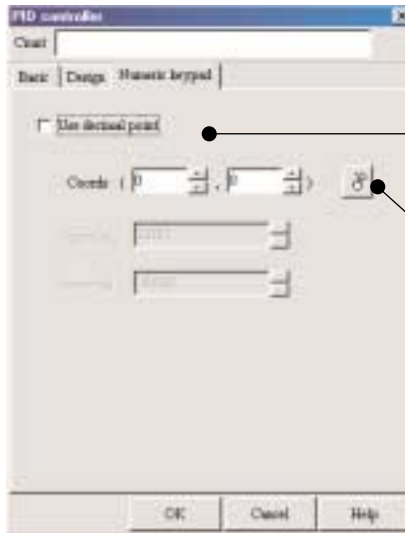

[Use decimal point]
Select this item when a numeric keypad panel with decimal point entry is to be used.

[Coordinates]
This item is for entering the call coordinates of the numeric keypad panel.

• Use decimal point

Call the numeric keypad panel having a decimal point entry function.

For details on the numeric keypad panel, see “5-2 Numeric Keypad” (page 5-4).

■ Smart Object Parameters

Tag name	Parameter name	Selection/setting item	Remarks
Basic	CMC10B use	Select when a SDC is connected via the CMC10B.	
	EST communications channel	Enter the communications channel on the EST.	1 to 4
	CMC10B device address	Enter the device address of the CMC10B.	1 to 127
	Controller device address	Enter the device address of the SDC30/31.	1 to 127
Design	Graphic type	Select the graphic type.	
	No.	Select the display graphic.	
	Fill color	Select the display color of the graphic.	
	PV color	Select the numeric display color of the PV.	
	SP color	Select the numeric display color of the SP.	
	MV color	Select the numeric value display color of MV.	
	Name	Enter the name.	
Numeric keypad	Use decimal point	Select when using a numeric keypad panel with decimal point input.	
	Coordinates	Enter the call coordinates of the numeric keypad panel.	

■ Supplementary Explanation

- Changes to the SP value are executed on the current SP value of the SDC30/31. The “current SP value” refers to the SP value of the currently selected SP set. For example, when the SP value is changed while SP3 is selected, SP3 will be rewritten.
- The settable range of the SP value is the lower SP limit to the upper SP limit in the setup on the SDC30/31.
- When the SP lamp is operating, the SP value in the lamp is displayed.
- For details on smart object settings, see “2-2 Main Configuration Items for Smart Objects” (page 2-5).

! Handling Precautions

- Set the communications channel to which the IMEC is to be connected to “Yamatake CPL general host link.”
- The panel may not function properly when the following items on the SDC30/31 are changed while a panel to which this smart object is pasted is activated. The panel will function properly by restarting the panel after the change has been made.
 - C02: Temperature unit
 - C04: Input range
 - C05: Decimal point position
 - C09: Lower SP limit
 - C10: Upper SP limit
- When the SP value has been changed in the Remote mode (when REM is lit), the execution SP does not change. However, the new SP value after the change becomes valid when the Local mode is returned to.

Smart object name	SDC40A (standard/remote SP type)					
Type	PID controller					
	Scaling				Paste coordinates	
	Enlarge	Reduce	Reshape	Scaling factor		Text size
				—	—	Any

■ **Function**

- This smart object enables monitoring of the run state of the SDC40A.
- The SP value can also be changed.

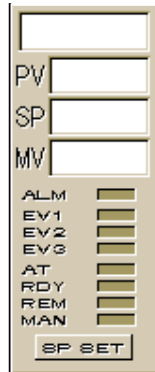

- PV: This displays the PV (process variable) value.
- SP: This displays the SP (set point) value.
- MV: This displays the MV (manipulated variable) value.
- ALM: This blinks when an alarm occurs.
- EV1: This lights when EV1 is ON.
- EV2: This lights when EV2 is ON.
- EV3: This lights when EV3 is ON.
- AT: This blinks during auto-tuning.
- RDY: This lights when the SDC10 is in the Ready mode.
- REM: This lights when the SDC30/31 is in the Remote SP mode.
- MAN: This lights when the SDC30/31 is in the Manual mode.
- SP SET: This button causes a numeric keypad to pop up so that the SP value can be changed.

■ **Configuration**

● **Basic**

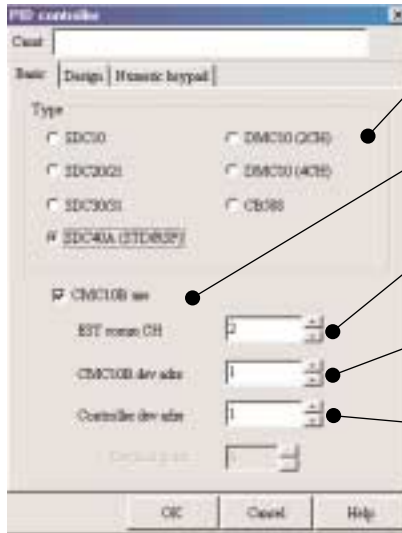

- [Type] This item is for selecting the IMEC type.
- [CMC10B use] Select this item when connecting the SDC40A via the CMC10B.
- [EST communications channel] This item is for entering the communications channel on the EST.
- [CMC10B device address] This item is for entering the device address of the CMC10B.
- [Controller device address] This item is for entering the device address of the SDC40A.

- **CMC10B use**
Select this item when the SDC40A is to be connected to the EST via the CMC10B.

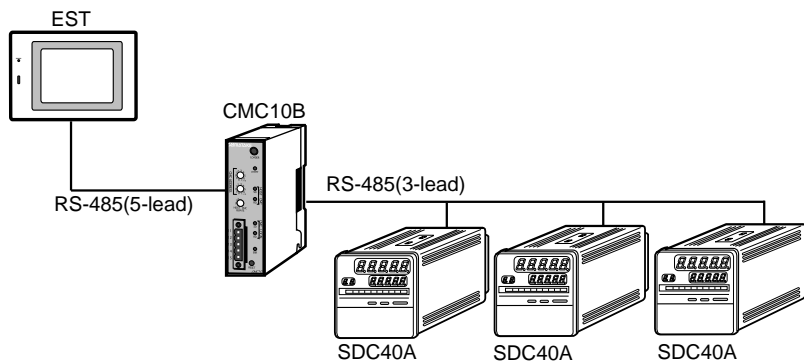

● Design

This sheet is for setting the graphic to be displayed on the smart object and the display color of the graphic.

Set the display text color and name of the PV, SP and MV values to be displayed on the smart object.

● Numeric keypad

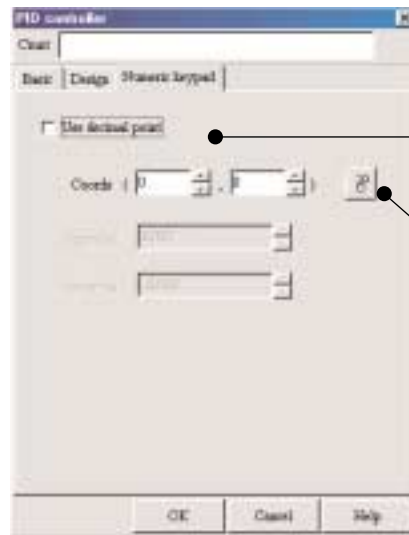

[Use decimal point]

Select this item when a numeric keypad panel with decimal point entry is to be used.

[Coordinates]

This item is for entering the call coordinates of the numeric keypad panel.

- Use decimal point

Call the numeric keypad panel having a decimal point entry function.

For details on the numeric keypad panel, see "5-2 Numeric Keypad" (page 5-4).

■ Smart Object Parameters

Tag name	Parameter name	Selection/setting item	Remarks
Basic	CMC10B use	Select when a SDC is connected via the CMC10B.	
	EST communications channel	Enter the communications channel on the EST.	1 to 4
	CMC10B device address	Enter the device address of the CMC10B.	1 to 127
	Controller device address	Enter the device address of the SDC40A.	1 to 127
Design	Graphic type	Select the graphic type.	
	No.	Select the display graphic.	
	Fill color	Select the display color of the graphic.	
	PV color	Select the numeric display color of the PV.	
	SP color	Select the numeric display color of the SP.	
	MV color	Select the numeric value display color of MV.	
	Name	Enter the name.	
Text color	Enter the name text color.		
Numeric keypad	Use decimal point	Select when using a numeric keypad panel with decimal point input.	
	Coordinates	Enter the call coordinates of the numeric keypad panel.	

■ Supplementary Explanation

- Changes to the SP value are executed on the LSP value of the currently selected SP set of the SDC40A. For example, when the SP value is changed while LSP3 is selected, LSP3 will be rewritten.
- The settable range of the SP value is the lower SP limit to the upper SP limit in the setup on the SDC40A.
- For details on smart object settings, see “2-2 Main Configuration Items for Smart Objects” (page 2-5).

! Handling Precautions

- Set the communications channel to which the IMEC is to be connected to “Yamatake CPL general host link.”
- The panel may not function properly when the following items on the SDC40A are changed while a panel to which this smart object is pasted is activated. The panel will function properly by restarting the panel after the change has been made.
 - C05: Input 1 temperature unit
 - C06: Input 1 range type
 - C07: Input 1 linear decimal point position
 - C16: Local SP setting method
 - C17: Upper SP limit
 - C18: Lower SP limit
- When the following setting is made in the setup on the SDC40A, the SP value cannot be changed. At this time, a short, high-pitched alarm buzzers and the numeric keypad does not pop up.
 - C16 = 3 (LSP cannot be set)
- When the SP value has been changed in the Remote mode (when REM is lit) on a remote SP type model, the execution SP does not change. However, the new SP value after the change becomes valid when the Local mode is returned to.

Smart object name	DMC10 (2 channel model)				
Type	PID controller				
Scaling					Paste coordinates
Enlarge	Reduce	Reshape	Scaling factor	Text size	
			—	—	Any

■ Function

- This smart object enables monitoring of the run state of the DMC10 (2 channel model).
- The SP value can also be changed.

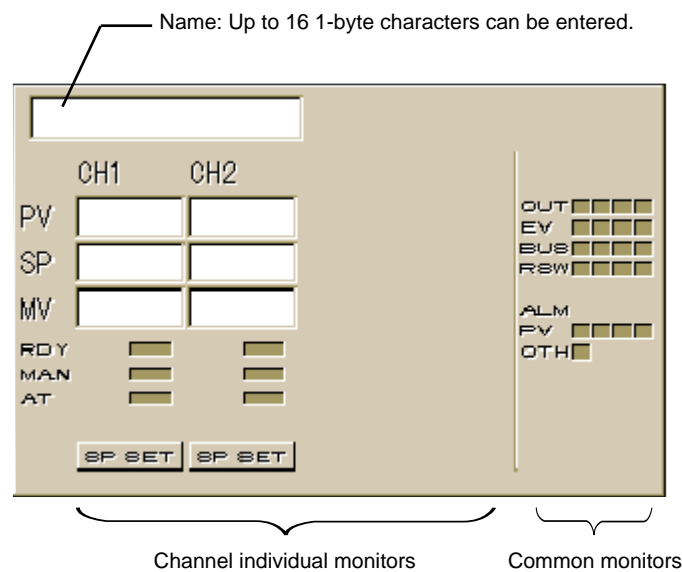

Channel individual monitors

- PV: This displays the PV (process variable) value.
 SP: This displays the SP (set point) value.
 MV: This displays the MV (manipulated variable) value.
 RDY: This lights when each channel is in the Ready mode.
 MAN: This lights when each channel is in the Manual mode.
 AT: This lights when auto-tuning is being executed on each channel.
 SP SET: Touching the [SP SET] button for each channel causes a numeric keypad to pop up so that the SP value can be changed.

Common monitors

- OUT: This lights when the output terminal of each channel is ON.
 EV: This lights when the EVENT terminal is ON.
 BUS: This lights when BUS output is ON.
 The state of the BUS output on the self module and not the OR-ed output of the BUS output of linked modules is displayed.
 RSW: This lights when the external contact input is ON.
 ALM (PV): This lights when the PV input terminal error occurs on each channel.
 ALM (OTH): This lights when other errors occur.

■ Configuration

● Basic

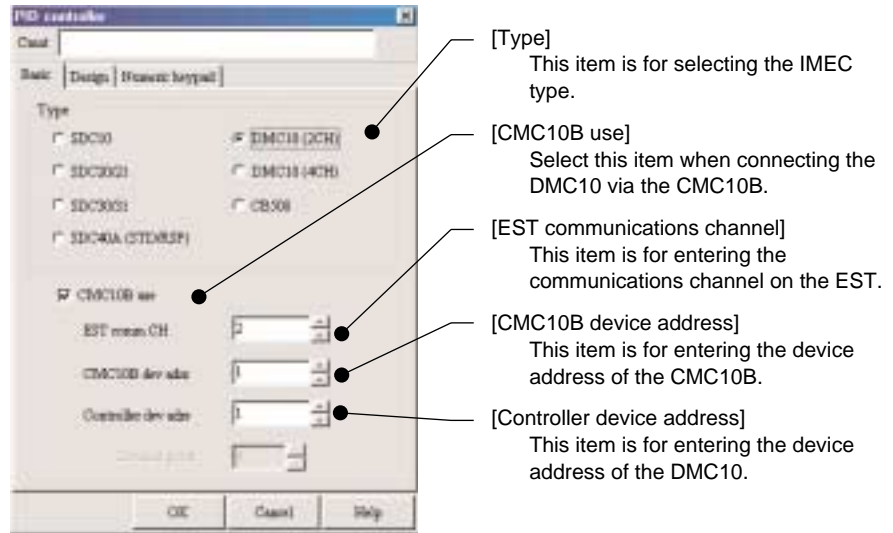

● CMC10B use

Select this item when the DMC10 is to be connected to the EST via the CMC10B.

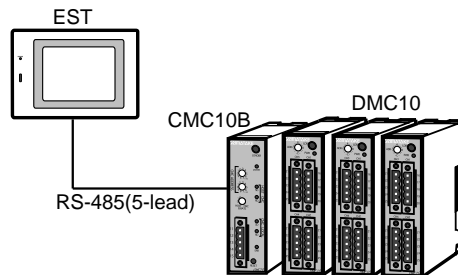

● Design

This sheet is for setting the graphic to be displayed on the smart object and the display color of the graphic.

Set the display text color and name of the PV, SP and MV values to be displayed on the smart object.

● Numeric keypad



[Use decimal point]

Select this item when a numeric keypad panel with decimal point entry is to be used.

- Use decimal point

Call the numeric keypad panel having a decimal point entry function.

For details on the numeric keypad panel, see "5-2 Numeric Keypad" (page 5-4).

■ Smart Object Parameters

Tag name	Parameter name	Selection/setting item	Remarks
Basic	CMC10B use	Select when connecting the DMC10 via the CMC10B.	
	EST communications channel	Enter the communications channel on the EST.	1 to 4
	CMC10B device address	Enter the device address of the CMC10B.	1 to 127
	Controller device address	Enter the device address of DMC10.	1 to 127
Design	Graphic type	Select the graphic type.	
	No.	Select the display graphic.	
	Fill color	Select the display color of the graphic.	
	PV color	Select the numeric display color of the PV.	
	SP color	Select the numeric display color of the SP.	
	MV color	Select the numeric value display color of MV.	
	Name	Enter the name.	
Numeric keypad	Use decimal point	Select when using a numeric keypad panel with decimal point input.	
	Coordinates	Enter the call coordinates of the numeric keypad panel.	

■ Supplementary Explanation

- Changes to the SP value of each channel are executed on the SP value of the currently selected SP set of the DMC10. For example, when the SP value is changed while SP3 is selected, SP3 will be rewritten.
- The settable range of the SP value is the lower SP limit to the upper SP limit in the setup on the DMC10.
- For details on smart object settings, see “2-2 Main Configuration Items for Smart Objects” (page 2-5).

! Handling Precautions

- Set the communications channel to which the PID controller is to be connected to “Yamatake CPL general host link.”
- The panel may not function properly when the following items on the DMC10 are changed while a panel to which this smart object is pasted is activated. The panel will function properly by restarting the panel after the change has been made.

Input type

Decimal point position

PV range lower limit

PV range upper limit

Lower SP limit

Upper SP limit

Smart object name	DMC10 (4 channel model)					
Type	PID controller					
	Scaling				Paste coordinates	
	Enlarge	Reduce	Reshape	Scaling factor		Text size
				—	—	Any

■ Function

- This smart object enables monitoring of the run state of the DMC10 (4 channel model).
- The SP value can also be changed.

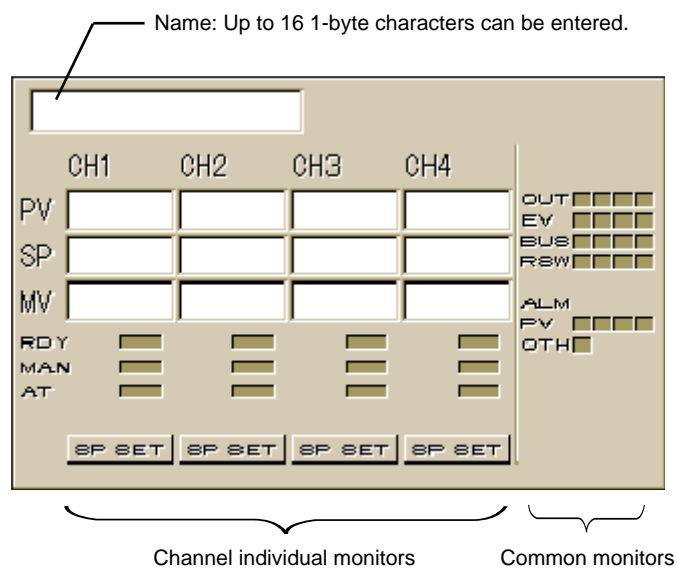

Channel individual monitors

- PV: This displays the PV (process variable) value.
 SP: This displays the SP (set point) value.
 MV: This displays the MV (manipulated variable) value.
 RDY: This lights when each channel is in the Ready mode.
 MAN: This lights when each channel is in the Manual mode.
 AT: This lights when auto-tuning is being executed on each channel.
 SP SET: Touching the [SP SET] button for each channel causes a numeric keypad to pop up so that the SP value can be changed.

Common monitors

- OUT: This lights when the output terminal of each channel is ON.
 EV: This lights when the EVENT terminal is ON.
 BUS: This lights when BUS output is ON.
 The state of the BUS output on the self module and not the OR-ed output of the BUS output of linked modules is displayed.
 RSW: This lights when the external contact input is ON.
 ALM (PV): This lights when the PV input terminal error occurs on each channel.
 ALM (OTH): This lights when other errors occur.

■ Configuration

● Basic

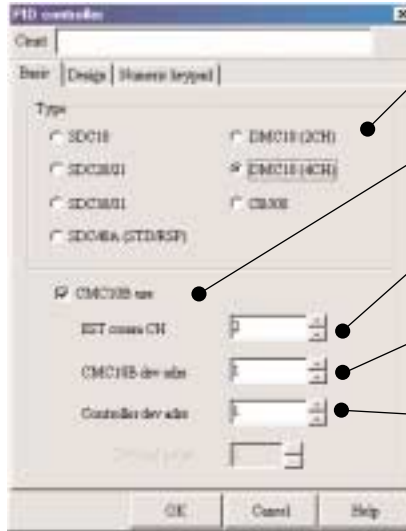

- [Type]
This item is for selecting the IMEC type.
- [CMC10B use]
Select this item when connecting the DMC10 via the CMC10B.
- [EST communications channel]
This item is for entering the communications channel on the EST.
- [CMC10B device address]
This item is for entering the device address of the CMC10B.
- [Controller device address]
This item is for entering the device address of the DMC10.

● CMC10B use

Select this item when the DMC10 is to be connected to the EST via the CMC10B.

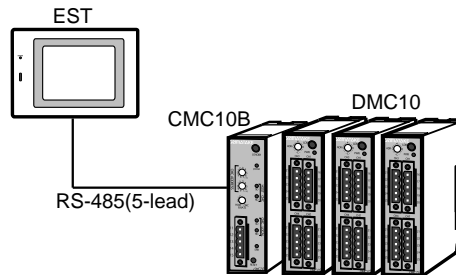

● Design

This sheet is for setting the graphic to be displayed on the smart object and the display color of the graphic.

Set the display text color and name of the PV, SP and MV values to be displayed on the smart object.

● Numeric keypad

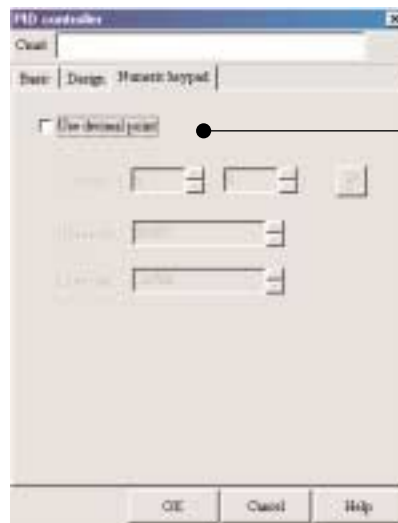

[Use decimal point]

Select this item when a numeric keypad panel with decimal point entry is to be used.

- Use decimal point

Call the numeric keypad panel having a decimal point entry function.

The numeric keypad panel is displayed at the right of the screen for channels 1 and 2, and at the left of the screen for channels 3 and 4.

For details on the numeric keypad panel, see “5-2 Numeric Keypad” (page 5-4).

■ Smart Object Parameters

Tag name	Parameter name	Selection/setting item	Remarks
Basic	CMC10B use	Select when connecting the DMC10 via the CMC10B.	
	EST communications channel	Enter the communications channel on the EST.	1 to 4
	CMC10B device address	Enter the device address of the CMC10B.	1 to 127
	Controller device address	Enter the device address of DMC10.	1 to 127
Design	Graphic type	Select the graphic type.	
	No.	Select the display graphic.	
	Fill color	Select the display color of the graphic.	
	PV color	Select the numeric display color of the PV.	
	SP color	Select the numeric display color of the SP.	
	MV color	Select the numeric value display color of MV.	
	Name	Enter the name.	
Text color	Enter the name text color.		
Numeric keypad	Use decimal point	Select when using a numeric keypad panel with decimal point input.	

■ Supplementary Explanation

- Changes to the SP value of each channel are executed on the SP value of the currently selected SP set of the DMC10. For example, when the SP value is changed while SP3 is selected, SP3 will be rewritten.
- The settable range of the SP value is the lower SP limit to the upper SP limit in the setup on the DMC10.
- For details on smart object settings, see “2-2 Main Configuration Items for Smart Objects” (page 2-5).

! Handling Precautions

- Set the communications channel to which the PID controller is to be connected to "Yamatake CPL general host link."
- The panel may not function properly when the following items on the DMC10 are changed while a panel to which this smart object is pasted is activated. The panel will function properly by restarting the panel after the change has been made.

- Input type
- Decimal point position
- PV range lower limit
- PV range upper limit
- Lower SP limit
- Upper SP limit

Smart object name	CB508					
Type	PID controller					
	Scaling				Paste coordinates	
	Enlarge	Reduce	Reshape	Scaling factor		Text size
				—	—	Any

■ **Function**

- This smart object enables monitoring of the run state of the CB508.
- The SP value can also be changed.

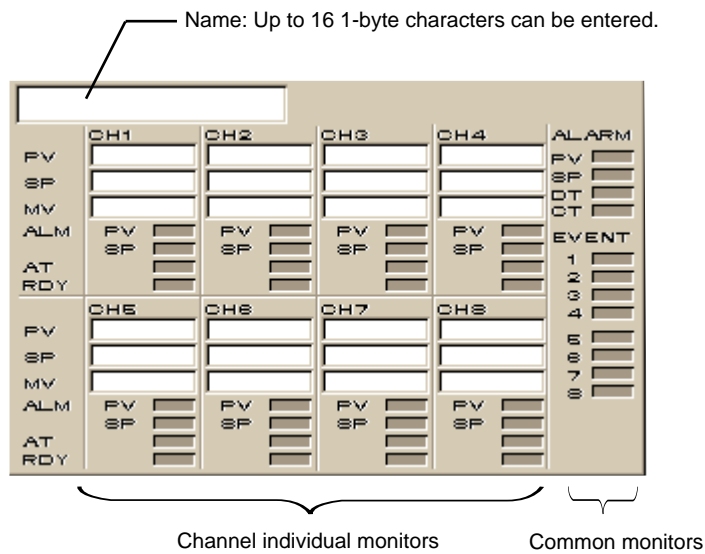

Channel individual monitors

- PV: This displays the PV (process variable) value.
- SP: This displays the SP (set point) value.
- MV: This displays the MV (manipulated variable) value.
- ALM (PV): This blinks when the PV or RTD wiring resistance is overrange.
- ALM (SP): This blinks when the SP value is out-of-range.
- AT: This blinks while auto-tuning is being executed.
- RDY: This lights when the CB508 is in the Ready mode.
- SP SET: Entry to an SP display field for each channel causes a numeric keypad to pop up so that the SP value can be changed.

Common monitors

- PV: This blinks when one of ALM (PV) on each channel is ON or when C/J is overrange.
- SP: This blinks when one of ALM (SP) on each channel is ON.
- DATA: This blinks when an internal data error occurs.
- CT: This blinks when CT is overrange.
- EV1 to EV8: This blinks when EV1 to EV8 is ON.

■ Configuration

● Basic

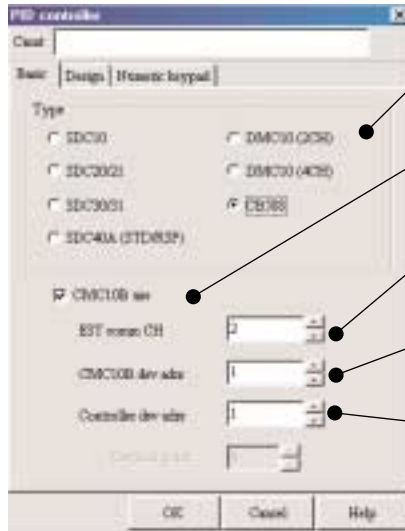

- [Type]
This item is for selecting the IMEC type.
- [CMC10B use]
Select this item when connecting the CB508 via the CMC10B.
- [EST communications channel]
This item is for entering the communications channel on the EST.
- [CMC10B device address]
This item is for entering the device address of the CMC10B.
- [Controller device address]
This item is for entering the device address of the CB508.

● CMC10B use

Select this item when the CB508 is to be connected to the EST via the CMC10B.

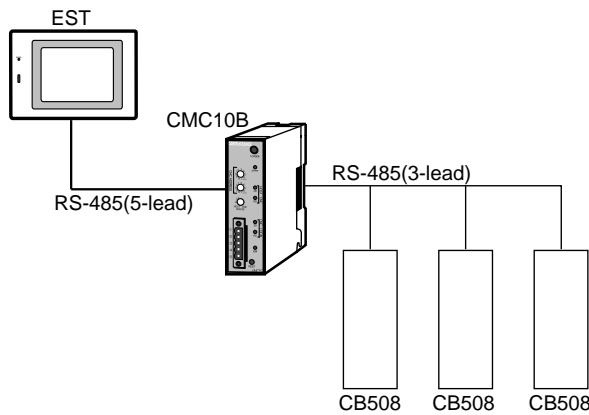

● Design

This sheet is for setting the graphic to be displayed on the smart object and the display color of the graphic.

Set the display text color and name of the PV, SP and MV values to be displayed on the smart object.

● Numeric keypad

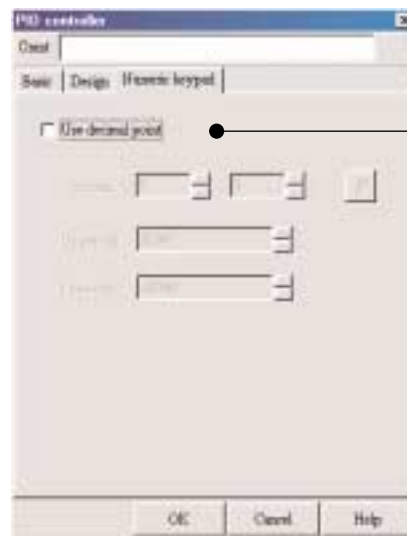

[Use decimal point]

Select this item when a numeric keypad panel with decimal point entry is to be used.

• Use decimal point

Call the numeric keypad panel having a decimal point entry function.

The numeric keypad panel is displayed at the right of the screen for channels 1, 2, 5 and 6, and at the left of the screen for channels 3, 4, 7 and 8.

For details on the numeric keypad panel, see "5-2 Numeric Keypad" (page 5-4).

■ Smart Object Parameters

Tag name	Parameter name	Selection/setting item	Remarks
Basic	CMC10B use	Select when connecting the CB508 via the CMC10B.	
	EST communications channel	Enter the communications channel on the EST.	1 to 4
	CMC10B device address	Enter the device address of the CMC10B.	1 to 127
	Controller device address	Enter the device address of CB508.	1 to 127
Design	Graphic type	Select the graphic type.	
	No.	Select the display graphic.	
	Fill color	Select the display color of the graphic.	
	PV color	Select the numeric display color of the PV.	
	SP color	Select the numeric display color of the SP.	
	MV color	Select the numeric value display color of MV.	
	Name	Enter the name.	
Text color	Enter the name text color.		
Numeric keypad	Use decimal point	Select when using a numeric keypad panel with decimal point input.	

■ Supplementary Explanation

- Changes to the SP value of each channel are executed on the SP value of the currently selected SP set of the CB508. For example, when the SP value is changed while SP3 is selected, SP3 will be rewritten.
- The settable range of the SP value is the lower SP limit to the upper SP limit in the setup on the CB508.
- When the SP lamp is operating, the SP value in the lamp is displayed.
- For details on smart object settings, see “2-2 Main Configuration Items for Smart Objects” (page 2-5).

! Handling Precautions

- Set the communications channel to which the PID controller is to be connected to “Yamatake CPL general host link.”
- The panel may not function properly when the following items on the CB508 are changed while a panel to which this smart object is pasted is activated. The panel will function properly by restarting the panel after the change has been made.

Common setup	Temperature unit
	PV range type
- CB518 is not supported.

4 - 2 Recipe

A “recipe” is a collection of various setting data for an external device.

Up to 200 recipes can be set. (The maximum number of recipes changes according to the number of configured data items.) The specified data will be written to the external device when triggered by an external device, or manual operation.

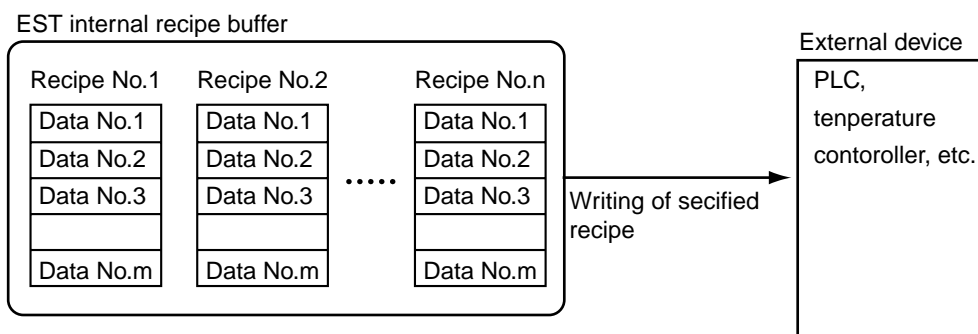

■ Recipe Operations

There are two ways to write data of recipes, manual write and auto write. By manual write, writing is started by manual operation on EST, and by auto write, writing is started by controlling the bits on the PLC. With both methods, writing is executed after the recipe to write is selected.

Recipe operation functions are set on recipe smart objects.

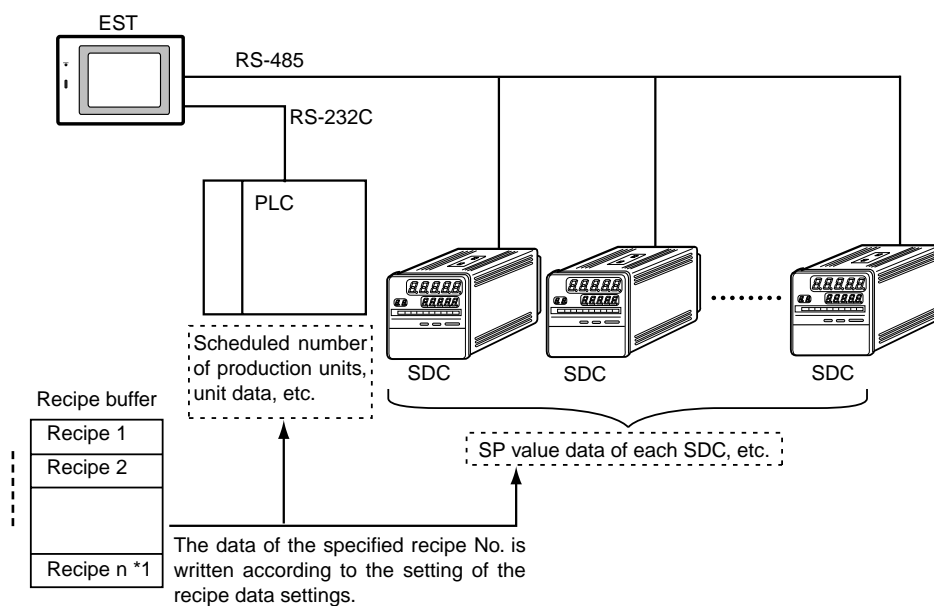

*1 Recipe n is changed by the number of data items saved by a recipe.

■ Recipe Write Methods

● Manual write

The data of the recipe No. currently displayed on the recipe smart object is written by operating the write switch assigned to the recipe smart object.

Note, however, that in the case of manual writing, writing of recipe data currently set to groups 2 to 4 is not possible. Set the group to group 1.

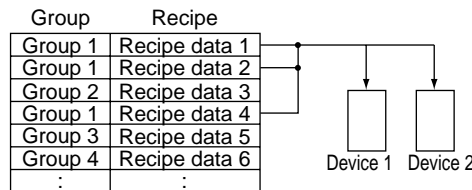

Writing of recipe data currently set to group 1 is executed by operating the write switch for the recipe smart object.

● Auto write

Recipe data is written by controlling devices on the PLC.

Write execution devices for recipe data can be set individually to each group.

Auto write can be used when the write timing of the data is to be changed within the same recipe.

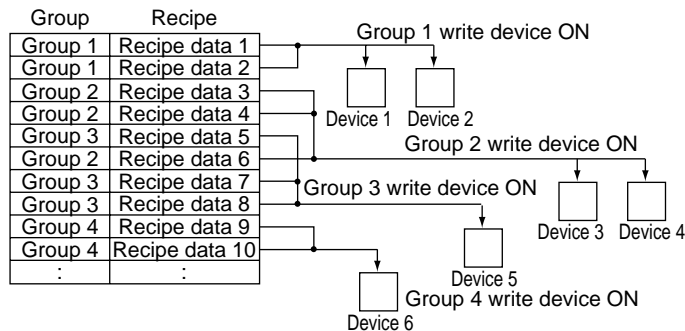

Writing of recipe data is executed by the state of the write execution devices in each group turning ON.

● Group

Recipe data has individual group configuration.

A “group” is a function used when the write timings of the recipe data on the external device differ within the same recipe.

Up to four groups can be set, and the write execution device of the data can be specified to each group when recipe data is to be written by controlling devices on the PLC.

■ Recipe Settings

The recipe data parameters are set at [Configuration Information] [Recipe Data] in AP Editor.

All recipe display and operations during writing comply with the content of this setting information.

In the recipe data settings, enter the following:

- Number of recipes
The number of files to save recipe data to
- Number of recipe data items
The number of recipe data items to save to a single recipe
- Recipe name
The name of each recipe (The name can be changed on smart objects.)
- Parameters
The parameter settings of each recipe data (group, write device address, etc.)
- Data settings
The settings of all recipe data

For details, see the Smart Terminal EST240Z User's Manual Application Preparation Manual No.CP-SP-1088E.

■ Area Required for Recipe Functions

When the recipe function is used on the EST, buffer area (recipe buffer) for storing the recipe data is secured as the special storage area on the EST.

The EST has five battery backed up special storage areas.

When the recipe function is used, one of the special storage areas is used as a recipe buffer.

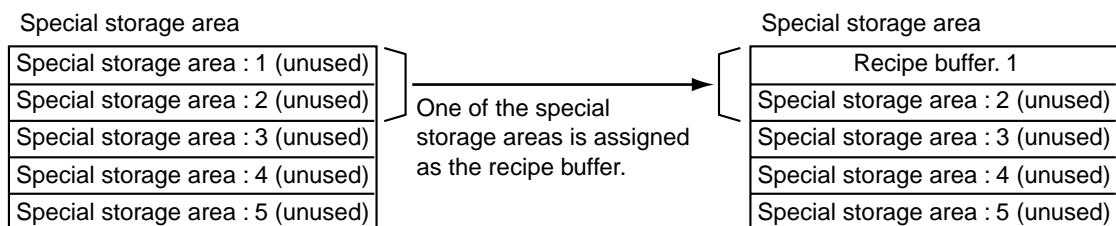

! Handling Precautions

The special storage area is used for recipe smart objects, trend smart objects and special packages. The recipe function cannot be used when all five special storage areas are used on functions other than the recipe function.

■ Recipe Data

The recipe buffer has a data storage area of 5000 words.

The number of recipes that can be set on the EST is 25 to 200.

The size of recipes that can be managed is calculated as follows:

$$5000 \geq \text{number of recipes} \times \text{number of words used per recipe}$$

■ Recipe Smart Objects

These smart objects display the recipe data currently stored on the EST.

The data currently set to the specified recipe No. can be displayed and the data modified and written.

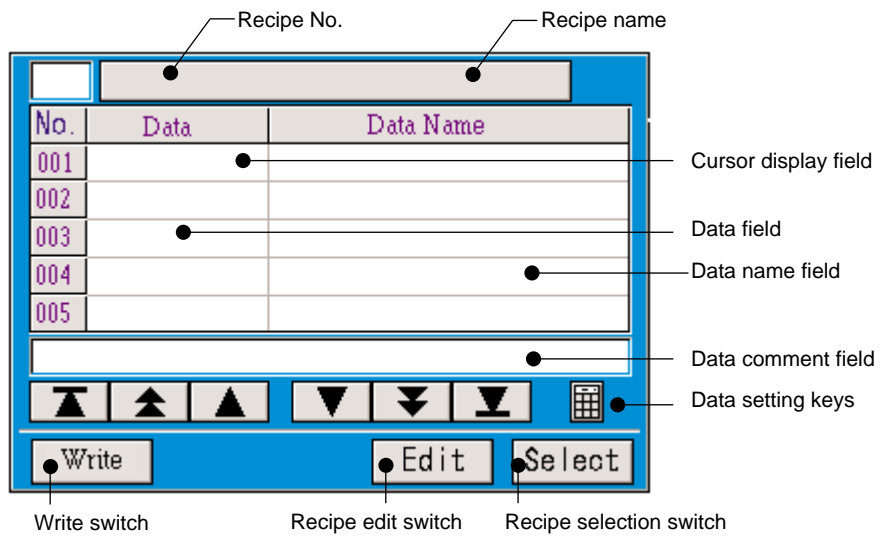

● Recipe No.

This displays the No. of the currently displayed recipe.

● Recipe name

This displays the name of the currently displayed recipe using up to 28 1-byte characters.

Touching the recipe name display area causes the keyboard panel to pop up and you can change the recipe name. Note, however, that when [Interlock] has been set in the recipe smart object settings, the keyboard panel is not called if the setting interlock device is OFF.

● Data field

This field displays the data currently set to the selected recipe.

- **Data name field**

This field displays the name corresponding to the data No. using up to 21 1-byte characters.

The data name that is displayed is set at [Application Manager] [Configuration Information] [Recipe Data] in AP Editor.

- **Cursor display field**

The cursor is displayed in the data display field if the recipe data can be set. The recipe data indicated by the cursor is the data that is to be set by the data setting keys.



- **Data comment field**



This field displays the comment for the recipe data corresponding to the data No. indicated by the cursor.

The data comment that is displayed is set at [Application Manager] [Configuration Information] [Recipe Data] in AP Editor.

- **Scroll keys**

These keys scroll the data to be displayed.

  : Display the start/final data.

  : Scroll display data five items at a time.

Holding down these switches scrolls the display data at high speed.

  : Scroll display data one item at a time.

Holding down these switches scrolls the display data at high speed.
If the cursor is displayed, the cursor display is scrolled.

- **Data setting keys**

Touching a data setting key causes a numeric keypad panel to pop up and you can change the values of the recipe data indicated by the cursor.

The setting range that can be entered by the numeric keypad for each recipe data is set at [Application Manager] [Configuration Information] [Recipe Data] in AP Editor.

The setting enabled/disabled state of the data setting keys can be controlled on an external PLC by setting [Interlock].

- **Recipe selection switch**

Touching this switch calls up the recipe selection panel.

On the recipe selection panel, select the recipe No. to be displayed on the smart object.

● **Recipe edit switch**

This switch is displayed when [Edit Function] has been selected in the recipe smart object settings.

Touching this switch calls up the recipe edit panel.

On the recipe edit panel, recipes can be duplicated and deleted.

The editing enabled/disabled state of the Edit switch can be controlled on an external PLC by setting [Interlock].

● **Write switch**

This switch is displayed when [Manual Write] has been selected in the recipe smart object settings.

Touching this switch writes the data of the currently displayed recipe No. to the currently specified external device.

The write enabled/disabled state of the Write switch can be controlled on an external PLC by setting [Write Interlock].

■ **Recipe Selection Panel**

This panel is called by touching the [Selection] switch of a recipe smart object.

The data of the recipe No. selected in the menu panel is displayed by smart object.

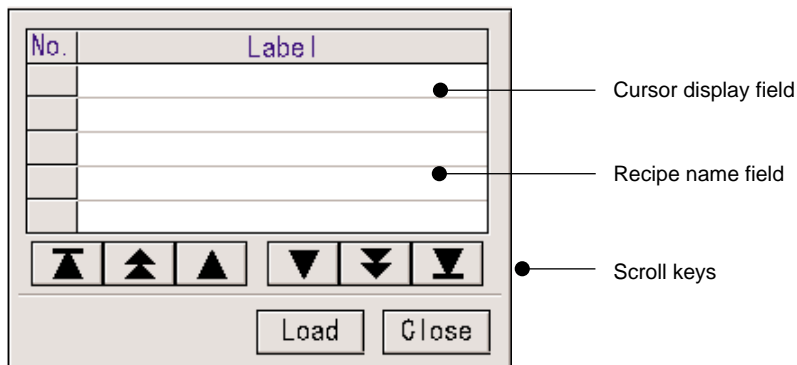

● **Recipe name**

This item displays the name of the currently set recipe using up to 28 1-byte characters.

● **Scroll keys**

These keys scroll the data to be displayed.

: Display the start/final data.

: Scroll display data five items at a time.

Holding down these switches scrolls the display data at high speed.

: Scroll display data one item at a time.

Holding down these switches scrolls the display data at high speed.

● **Read**

This buttons displays the data of the recipe No. at the cursor display field on the recipe smart object.

● **Close**

This button cancels the selection and returns to the call panel.

■ Recipe Edit Panels

This panel is called by touching the [Edit] switch of a recipe smart object. On this panel, recipe data can be deleted and duplicated.

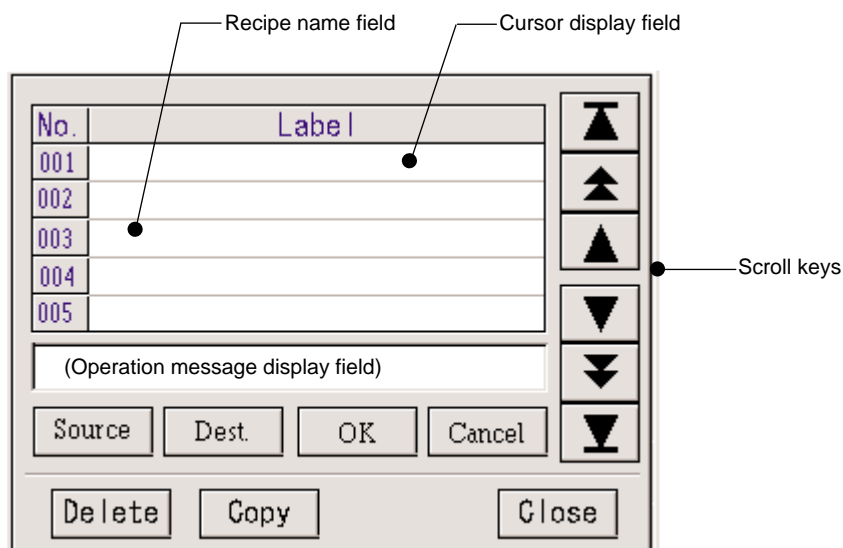



● Recipe name field

This item displays the name of the currently set recipe using up to 28 1-byte characters.

● Scroll keys

These keys scroll the data to be displayed.

  : Display the start/final data.

  : Scroll display data five items at a time.

Holding down these switches scrolls the display data at high speed.

  : Scroll display data one item at a time.

Holding down these switches scrolls the display data at high speed.

● Delete

This item deletes the data of the recipe No. at the cursor display field.

The confirmation message is displayed. Determine the delete by either the [OK] or [Cancel] key.

● Copy

This item duplicates the selected recipe data to the specified recipe.

Select the recipe to be duplicated using the cursor, and enter the duplicate source and destination by the [Source] and [Dest.] keys.

At this time, the confirmation message is displayed. Determine the duplicate by either the [OK] or [Cancel] key.

The name of the duplicate source recipe is prefixed by “*” as the name of the duplicated recipe data.

● Close

This item returns to the call panel.

■ Operation of Manual Write Smart Objects

The following shows the operation of smart objects when [Manual Write] has been selected for recipe smart objects.

No.	Data	Data Name
001	100.0	DMC10(1)-CH1 SP Value
002	150.0	DMC10(1)-CH2 SP Value
003	130.0	DMC10(2)-CH1 SP Value
004	170.0	DMC10(2)-CH2 SP Value
005	200.0	DMC10(2)-CH3 SP Value

● **Recipe data setting**

The recipe data to be displayed at the smart object is set at [Set Recipe Data] in AP Editor.

Write Edit Select

● **Recipe data write (step 2)**

The data of the recipe No. currently displayed by the smart object is written to the set device. [Confirmation of write]

No.	Data	Data Name
001	100.0	DMC10(1)-CH1 SP Value
002	150.0	DMC10(1)-CH2 SP Value
003	130.0	DMC10(2)-CH1 SP Value
004	170.0	DMC10(2)-CH2 SP Value
005	200.0	DMC10(2)-CH3 SP Value

Execute data write.

OK Cancel

● **Recipe selection panel (step 1)**

Select the recipe to be displayed at the smart object and read that data to the smart object.

No.	Label
001	Control Program No.001
002	Control Program No.002
003	Control Program No.003
004	Control Program No.004
005	Control Program No.005

Load Close

● **Recipe data setting**

Call the numeric keypad panel, and change the value of the recipe data currently displayed at the cursor.

No.	Data	Data Name
001	110.0	DMC10(1)-CH1 SP Value
002	150.0	DMC10(1)-CH2 SP Value
003	130.0	DMC10(2)-CH1 SP Value
004	170.0	DMC10(2)-CH2 SP Value
005	200.0	DMC10(2)-CH3 SP Value

110.0 ESC

7 8 9 CL

4 5 6 RS

1 2 3 ENT

0 - +

[Transmitting]

No.	Data	Data Name
001	100.0	DMC10(1)-CH1 SP Value
002	150.0	DMC10(1)-CH2 SP Value
003	130.0	DMC10(2)-CH1 SP Value
004	170.0	DMC10(2)-CH2 SP Value
005	200.0	DMC10(2)-CH3 SP Value

Transmitting data...

OK Cancel

● **Recipe edit panel**

Perform copy/delete operations on the recipe data.

No.	Label
001	Control Program No.001
002	Control Program No.002
003	Control Program No.003
004	Control Program No.004
005	Control Program No.005

Copy from No.— to No.— ?

Source Dest OK Cancel

Delete Copy Close

[Confirmation of write result]

No.	Data	Data Name
001	100.0	DMC10(1)-CH1 SP Value
002	150.0	DMC10(1)-CH2 SP Value
003	130.0	DMC10(2)-CH1 SP Value
004	170.0	DMC10(2)-CH2 SP Value
005	200.0	DMC10(2)-CH3 SP Value

Completed Successfully

OK Cancel

Smart objects that do not have editing functions also can be called according to the smart object's setting.

■ Operation of Auto Write Smart Objects

The following shows the operation of smart objects when [Auto Write] has been selected for recipe smart objects.

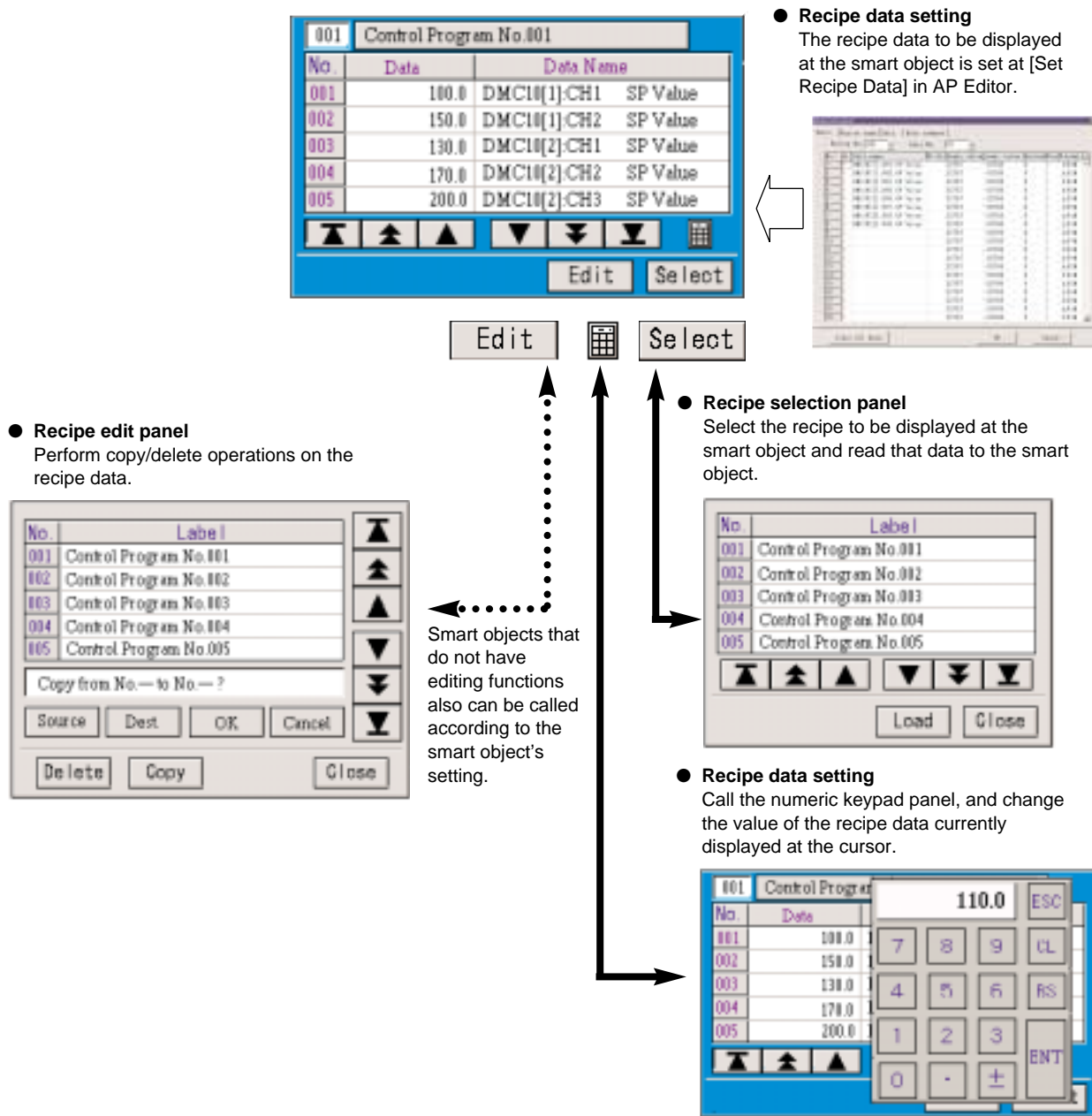

● Writing of recipe data

Writing of recipe data when auto write smart objects are used is controlled on a PLC or other external device. The following device controls are available on the external device:

- Recipe No. designated device. Device that sets the write recipe No. to external devices
- Write execution deviceBit device that executes writing of recipe data
- Normal end notification.....Bit device that notifies that writing of recipe data ended normally
- Error end notificationBit device that notifies that writing of recipe data ended abnormally

The group must be set individually to recipe data.

The data write timing (write execution device/normal end notification/abnormal end notification) can be specified individually to each group on recipe auto write smart objects.

Smart object name	Manual write				
Type	Recipe				
Scaling					Paste coordinates
Enlarge	Reduce	Reshape	Scaling factor	Text size	
			—	—	Any

■ **Function**

- This smart object shows the data currently set to the selected recipe No. and its data name in the form of a table.
- Touching the [Select] switch calls the recipe selection panel. On the recipe selection panel, select the recipe No. to be displayed on the recipe smart object.
- The currently display recipe data can be corrected.
- The data of the recipe No. currently displayed for the recipe smart object can be written to the external device by touching the [Write] switch.

■ **Configuration**

● **Basic**

The screenshot shows a configuration window for a recipe smart object. It includes fields for 'Recipe' (100) and 'Data' (25), checkboxes for 'Manual write' and 'Auto write', and several bit device settings: 'Interlock', 'Write interlock', 'Notify dev use', 'Range H/L', 'Normal dev', and 'Error dev'. Callouts point to these settings with the following descriptions:

- [Recipes]**: This item displays the number of recipes set in the recipe data settings.
- [Data]**: This item displays the number of data items set in the recipe data settings.
- [Type]**: This item is for selecting the type of recipe smart object.
- [Interlock]**: This item is for entering the bit device for enabling editing of recipe data.
- [Write interlock]**: This item is for entering the bit device for enabling the write switch.
- [Notify device use]**: This item is for notifying the external PLC of the state during recipe writing.

• **Interlock**

Enter the bit device on the PLC for enabling editing of recipe smart objects. Recipe smart object change functions include functions for setting the recipe data, setting the recipe name and editing recipes. These functions can be set when the setting interlock device is ON.

Recipe data setting: Touching the [Data Setting] key calls up the numeric keypad panel. Change the recipe data to the data entered on the numeric keypad panel.

Recipe name setting: Touching the recipe name display field calls up the keyboard panel. Change the recipe name to the data entered on the keyboard panel.

Recipe edit: Touching the [Edit] key calls up the recipe edit panel. Recipes can be duplicated and deleted on this panel.

- Write interlock

Enter the bit device on the PLC for enabling operation of the [Write] switch when executing writing of recipe data by the Write switch on the recipe smart object.

The [Write] switch can be operated when the interlock device is ON.

- Notify device use

This item notifies the external PLC of the operating state when writing recipe data.

The following three data items are notified:

Recipe No. (word device): Notifies the recipe No. using binary data.

Normal end (bit device): Turns the bit ON at normal end of writing.

Abnormal end (bit device): Turns the bit ON at abnormal end of writing.

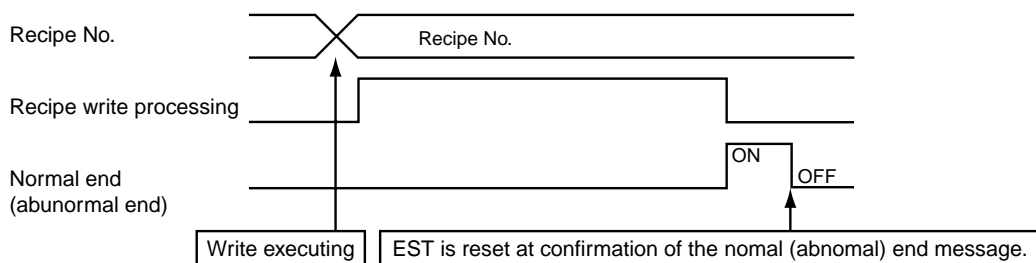

- Design

The screenshot shows the 'Recipe' configuration window with various settings. Callouts point to specific elements:

- [Data title]**: This item is for entering the display title of the data.
- [Name title]**: This item is for entering the display title of the data name.
- [Edit function]**: This item is for selecting whether or not to provide the Edit switch.
- [Data comment]**: Select this item to attach a display function for the recipe data comment.
- [No.]**: This item is for selecting the display graphic of the recipe.
- [Fill color]**: This item is for selecting the display color of the graphic.
- [Cursor]**: This item is for selecting the display color of cursor display.
- [Comment]**: This item is for selecting the display text color of the recipe data comment.

A small table is also visible in the top right of the window:

No.	Data Title	Name Title
001		
002		

- With edit functions

This item is for selecting whether or not to provide a recipe edit panel call function.

The [Edit] switch is not displayed for the smart object when the edit function is not used.

- Data comment

This item displays a comment for the recipe data currently indicated by the cursor using up to 36 1-byte characters.

- Numerical keypad

This sheet is for specifying the call coordinates of numeric keypads and keyboards.

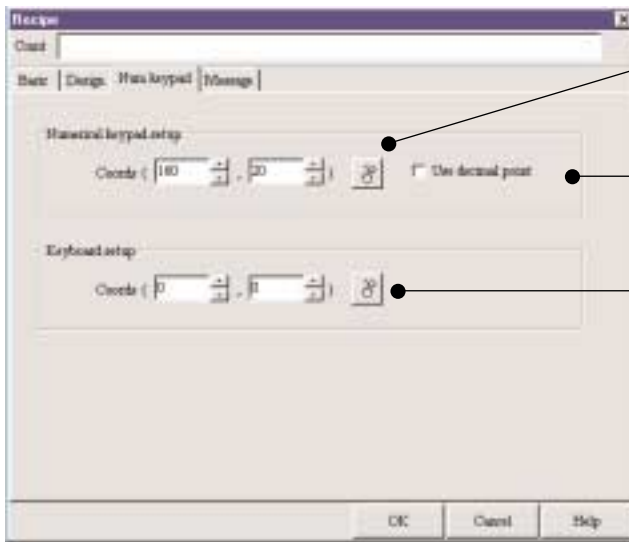

[Numerical keypad]
This item is for entering the call coordinates of the numeric keypad panel.

[Use decimal point]
Select this item when a numeric keypad panel with decimal point key is used.

[Keyboard setup]
This item is for entering the call coordinates of the keyboard panel.

- Messages

This sheet is used for entering messages that are displayed when writing of recipe data is executed.

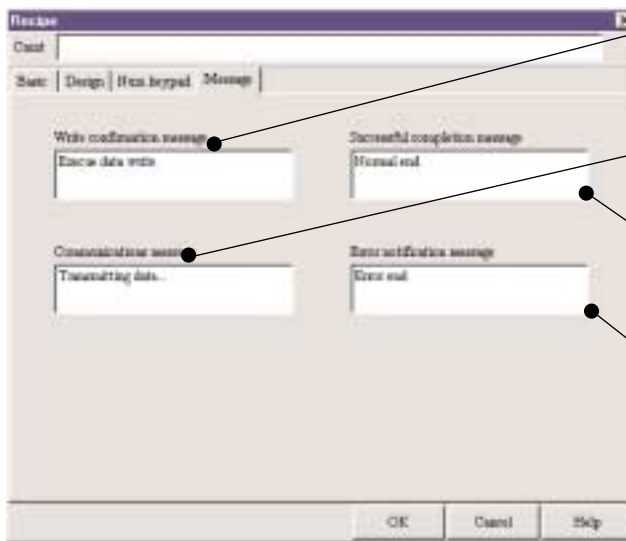

[Write confirmation message]
This item is for entering the message to be displayed at confirmation of writing.

[Communications message]
This item is for entering the message that is displayed during writing of recipe data.

[Successful completion message]
This item is for entering the message that is displayed at normal end of writing.

[Error notification message]
This item is for entering the message that is displayed at abnormal end of writing.

■ Smart Object Parameters

Tab name	Parameter name	Selection/setting item	Remarks
Basic	Interlock	Enter the communications channel, the device address, and the bit device.	When the setting interlock is used
	Write Interlock	Enter the communications channel, the device address, and the bit device.	When the write interlock is used
	Recipe No.	Enter the communications channel, the device address, and the word device.	When the notify device is used
	Normal device	Enter the communications channel, the device address, and the bit device.	
	Error device	Enter the communications channel, the device address, and the bit device.	
Design	Data title	Enter the display title of the recipe data field.	
	Name title	Enter the display title of the recipe name field.	
	Edit function	Select presence of the edit panel call switch.	
	Data comment	Select when displaying the recipe data comment.	
	No.	Select the display graphic.	
	Fill color	Select the display color of the graphic.	
	Cursor	Select the display color of the cursor.	
	Comment	Select the display text color of the recipe data comment.	When the data comment is displayed
Numerical keypad	Numeric keypad call coordinates	Enter the call coordinates of the numeric keypad panel.	
	Use decimal point	Select when the numeric keypad panel with decimal point input is used.	
	Keyboard call coordinates	Enter the call coordinates of the keypad panel.	
Message	Write confirmation message	Enter the message to be displayed when confirming writing.	
	Communications message	Enter the message to be displayed during communications.	
	Normal end message	Enter the message to be displayed at normal end.	
	Error end message	Enter the message to be displayed at error end.	

■ Supplementary Explanation

- The name set at [Configuration Information] [Recipe Data] in AP Editor is displayed at the recipe name, data name and data comment.
- The recipe name written by the smart object is reflected in internal registers (SR95100 to 95125) on the EST. The currently executing recipe name can be displayed by using a variable string smart object to specify that storage register (SR95100).
- To use a recipe smart object, the recipe must be set at [Configuration Information] [Recipe Data] in AP Editor. For details, see the Smart Terminal EST240Z User's Manual Application Preparation Manual No.CP-SP-1088E.

! Handling Precautions

- One of the special storage areas is used as the recipe buffer for recipe functions.
Special storage areas are also used for trend smart objects and special packages. For this reason, the recipe function cannot be used when all five special storage areas are used on functions other than the recipe function.
- Enter the bit device on the PLC at Settings interlock/Write interlock. Do not enter word devices such as registers.
- Be sure to enter a multiple of 16 when entering the bit device to the recipe No.
- Enter the bit device on the PLC at Normal end/Abnormal end. Do not enter word devices such as registers.
- When recipe data is written, if a recipe No. to which a recipe name is not set is currently set to the recipe No. specified device, the recipe data itself is also judged to be undetermined data. Writing of this data is not executed to the external device and is processed as an error.
- Writing of recipe data is executed on recipe data currently set to group 1 and is not executed on the recipe data of groups 2 to 4.

Smart object name	Auto write				
Type	Recipe				
Scaling					Paste coordinates
Enlarge	Reduce	Reshape	Scaling factor	Text size	
			—	—	Any

■ Function

- This smart object shows the data currently set to the selected recipe No. and its data name in the form of a table.
- Touching the [Select] switch calls the recipe selection panel. On the recipe selection panel, select the recipe No. to be displayed on the recipe smart object.
- The currently display recipe data can be corrected.
- The recipe No. can be specified on the PLC to start writing of recipe data. Start of recipe data writing can be set individually to each recipe group.

■ Configuration

● Basic

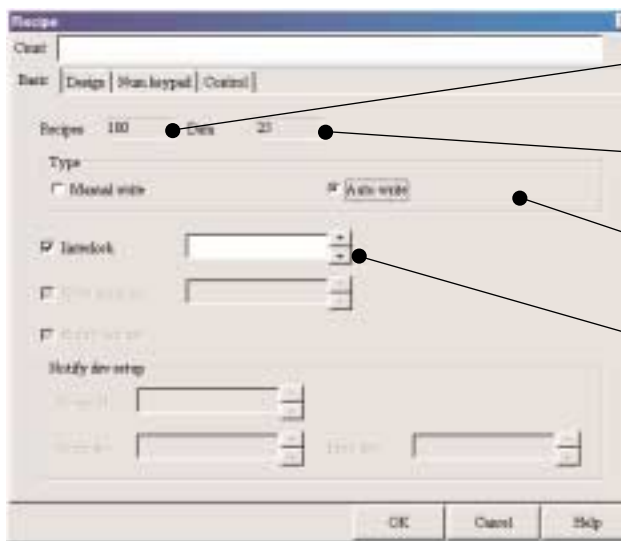

- [Recipes] This item displays the number of recipes set in the recipe data settings.
- [Data] This item displays the number of data items set in the recipe data settings.
- [Type] This item is for selecting the type of recipe smart object.
- [Interlock] This item is for entering the bit device for enabling editing of recipe data.

- Interlock Enter the bit device on the PLC for enabling editing of recipe smart objects. Recipe smart object change functions include functions for setting the recipe data, setting the recipe name and editing recipes. These functions can be set when the setting interlock device is ON.

Recipe data setting: Touching the [Data Setting] key calls up the numeric keypad panel. Change the recipe data to the data entered on the numeric keypad panel.

Recipe name setting: Touching the recipe name display field calls up the keyboard panel. Change the recipe name to the data entered on the keyboard panel.

Recipe edit: Touching the [Edit] key calls up the recipe edit panel. Recipes can be duplicated and deleted on this panel.

● Design

[Data title]
This item is for entering the display title of the data.

[Name title]
This item is for entering the display title of the data name.

[Edit function]
This item is for selecting whether or not to provide the Edit switch.

[Data comment]
Select this item to attach a display function for the recipe data comment.

[No.]
This item is for selecting the display graphic of the recipe.

[Fill col]
This item is for selecting the display color of the graphic.

[Cursor]
This item is for selecting the display color of cursor display.

[Comment]
This item is for selecting the display text color of the recipe data comment.

- Edit function
This item is for selecting whether or not to provide a recipe edit panel call function. The [Edit] switch is not displayed for the smart object when the edit function is not used.
- Data comment
This item displays a comment for the recipe data currently indicated by the cursor using up to 36 1-byte characters.

● Number keys

This sheet is for specifying the call coordinates of numeric keypads and keyboards.

[Numerical keypad]
This item is for entering the call coordinates of the numeric keypad panel.

[Use decimal point]
Select this item when a numeric keypad panel with decimal point key is used.

[Keyboard setup]
This item is for entering the call coordinates of the keyboard panel.

● Control

This sheet is for entering the PLC device that is to execute writing of recipe data.

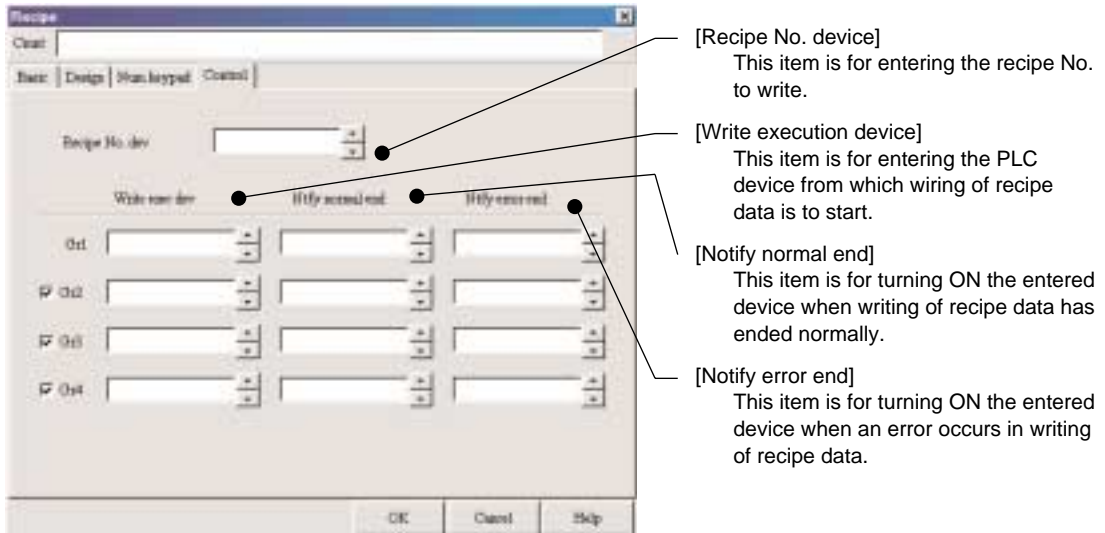

- **Recipe No. device**
Enter the PLC device to which the recipe No is to be written is stored.
- **Write execution device**
Writing of the recipe data of the recipe No. current set to the recipe No. specified device when the write execution device is started up.
By the write execution device, the EST is reset to OFF when wiring of recipe data ends.
- **Notify normal end**
The bit device entered to this item is set to ON when writing of recipe data has ended normally. On the EST, the normal end notification device is not reset to OFF. On the PLC, reset the normal end notification device to OFF after confirmation that the device has turned ON.
- **Notify error end**
The bit device entered to this item is set to ON when a recipe data write error occurs when writing of recipe data has ended abnormally. On the EST, the abnormal end notification device is not reset to OFF. On the PLC, reset the abnormal end notification device to OFF after confirmation that the device has turned ON.

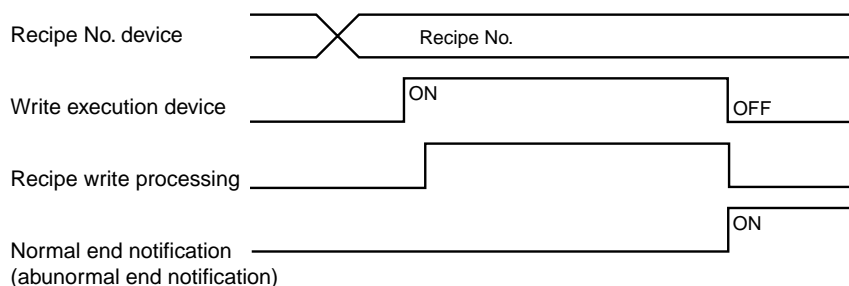

- **Group**
Up to four groups can be set to each recipe data. For writing of recipe data, set the write execution device to the group of each recipe data.

■ Smart Object Parameters

Tab name	Parameter name	Selection/setting item	Remarks
Basic	Setting interlock	Enter the communications channel, the device address, and the bit device.	When the setting interlock is used
Design	Data title	Enter the display title of the recipe data field.	
	Name title	Enter the display title of the recipe name field.	
	With edit function	Select presence of the edit panel call switch.	
	Data comment	Select when displaying the recipe data comment.	
	No.	Select the display graphic.	
	Fill color	Select the display color of the graphic.	
	Cursor	Select the display color of the cursor.	
	Comment	Select the display text color of the recipe data comment.	When the data comment is displayed
Number keys	Coordinates	Enter the call coordinates of the numeric keypad panel.	
	Use decimal point	Select when the numeric keypad panel with decimal point input is used.	
	Coordinates	Enter the call coordinates of the keypad panel.	
Control	Recipe No. device	Enter the communications channel, the device address, and the word device.	
	Group 1: Write execution device	Enter the communications channel, the device address, and the bit device.	
	Group 1: Notify normal end	Enter the communications channel, the device address, and the bit device.	
	Group 1: Notify error end	Enter the communications channel, the device address, and the bit device.	
	Group 2: Write execution device	Enter the communications channel, the device address, and the bit device.	When group 2 is selected
	Group 2: Notify normal end	Enter the communications channel, the device address, and the bit device.	
	Group 2: Notify error end	Enter the communications channel, the device address, and the bit device.	
	Group 3: Write execution device	Enter the communications channel, the device address, and the bit device.	When group 3 is selected
	Group 3: Notify normal end	Enter the communications channel, the device address, and the bit device.	
	Group 3: Notify error end	Enter the communications channel, the device address, and the bit device.	
	Group 4: Write execution device	Enter the communications channel, the device address, and the bit device.	When group 4 is selected
	Group 4: Notify normal end	Enter the communications channel, the device address, and the bit device.	
	Group 4: Notify error end	Enter the communications channel, the device address, and the bit device.	

■ Supplementary Explanation

- Writing of recipe data is executed by PLC control regardless of the display state of the smart object.
Accordingly, writing of recipe data is executed if writing is performed from the PLC even in a state where a panel on which a recipe smart object is not displayed is displayed.
- With auto write smart objects, writing of recipe data is controlled on the PLC. For this reason, that smart object itself becomes a smart object for displaying and editing recipe data.
- The name set at [Configuration Information] [Recipe Data] in AP Editor is displayed at the recipe name, data name and data comment.
- The name written by the smart object is reflected in internal registers on the EST. The currently executing recipe name can be displayed by using a variable string smart object to specify the start device of that storage register.

Group 1: SR95100 to 95125

Group 2: SR95126 to 95151

Group 3: SR95152 to 95177

Group 4: SR95178 to 95203

- To use a recipe smart object, the recipe must be set at [Configuration Information] [Recipe Data] in AP Editor. For details, see the Smart Terminal EST240Z User's Manual Application Preparation Manual No.CP-SP-1088E.

Handling Precautions

- One of the special storage areas is used as the recipe buffer for recipe functions.
Special storage areas are also used for trend smart objects and special packages. For this reason, the recipe function cannot be used when all five special storage areas are used on functions other than the recipe function.
- Enter the bit device on the PLC at Settings interlock. Do not enter word devices such as registers.
- Be sure to enter a multiple of 16 when entering the bit device to the recipe No. device.
- Enter the bit device on the PLC at Write execution device/Notify normal end/Notify error end. Do not enter word devices such as registers.
- When writing of recipes is executed, if a recipe No. to which a recipe name is not set is currently set to the recipe No. specified device, the recipe data itself is also judged to be undetermined data. Writing of this data is not executed to the external device and is processed as an error.
- When writing of recipe is executed, if a recipe No. currently set to the specified device is "0" or larger than the number of set recipes, writing is processed as a write error.
- Writing of recipe data is executed by detection of the write execution device turning ON.
If the OFF state of the write execution device is short when writing of the recipe data of the same group is executed continuously, the EST cannot detect startup of the write execution device, and writing of recipe data is sometimes not executed. Be sure to provide an OFF state of the write execution device.
- If an error occurs in communications with the external device when writing of recipe data is being executed, recipe data write completion (notify normal end/notify error end) cannot be notified normally.
On devices that control writing of recipes, monitor the time until write completion (normal end notification/abnormal end notification) turns ON from when the write execution device turns ON. (This is monitoring of the time-out time.)
The time to be set as the time-out time differs according to the application. Determine the time-out time from the time required for writing the recipe data during normal operation.
When executing retry processing when an error occurs, set the write execution device to ON after providing the OFF state for the write execution device.

4 - 3 Trend

Trends are smart objects that sample the data of external devices at a fixed cycle, and display changes in data as a trend graph.

The data of the sampled device set on the trend smart object is stored to the internal buffer on the EST at the intervals of the sampling cycle.

The data of trends (1 to 8 channels) and events (0 to 3 channels) can be sampled and displayed on a single trend smart object.

When a variable trend smart object is used, the sampling device of the trend and sampling cycle can be changed on the EST. (Trends and events can be selected from up to 40 sampling devices for each trend smart object.)

■ Trend Buffers

Buffer area (trend buffer) for storing data sampled by the trend smart object is secured to special storage area on the EST .

The EST has five battery backed up special storage areas.

A trend smart object secures the trend buffer to be used by that object to special storage area to sample and display data according to the number of channels to be sampled and the number of stores per channel.

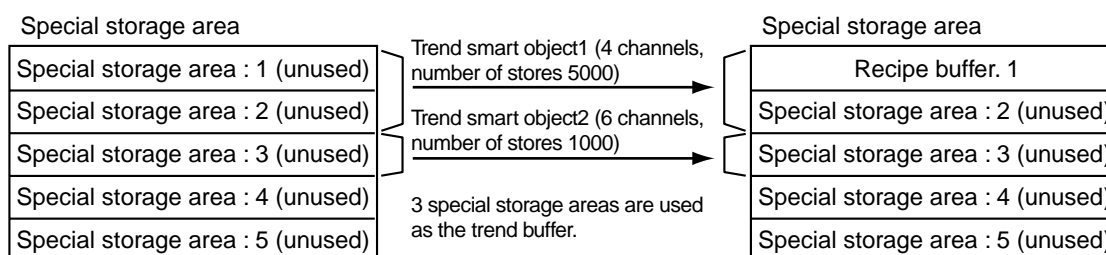

! Handling Precautions

The special storage area is used for recipe smart objects, trend smart objects and special packages. Trend smart objects cannot be used when all five special storage areas are used.

■ Trend Displays

Data stored to trend buffer is displayed as follows on trend smart objects.

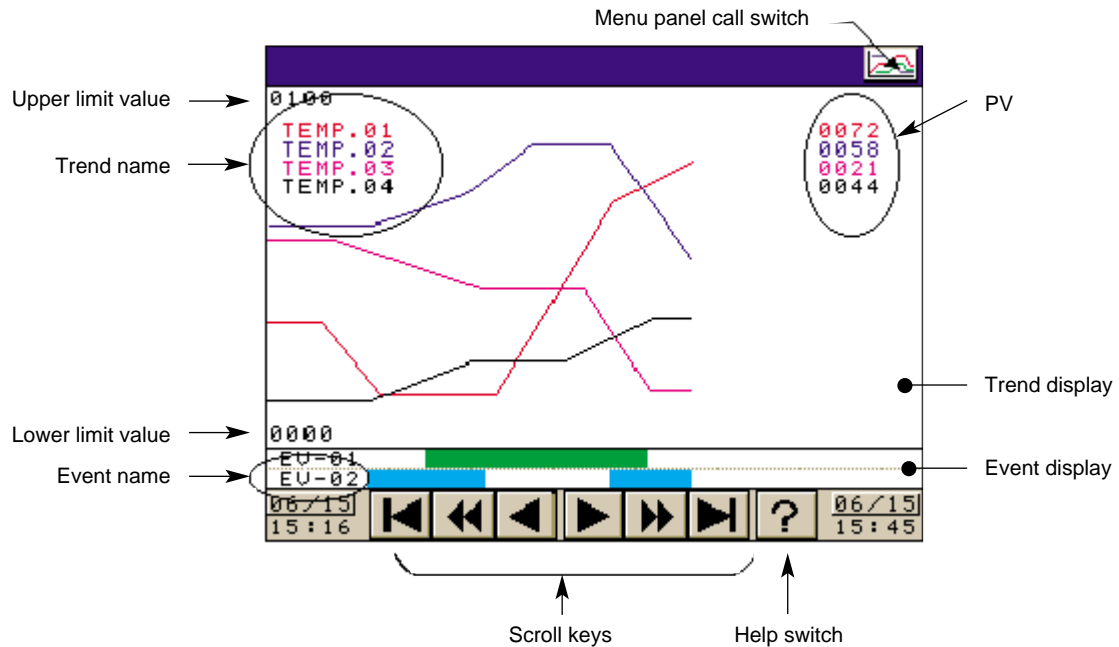

● Menu panel call switch

Touching the icon display area for the trend for three seconds causes the trend menu panel to pop up.

On this panel, you can change the upper and lower limit values and set the trend data display.

● Upper limit value/Lower limit value

The display upper and lower limit values of the Y axis are displayed.

In the case of variable trend smart objects, the numeric keypad panel is displayed by touching the upper/lower limit value display area for three seconds. On this panel, you can change the upper/lower limit values.

● Help switch

The trend name, PV and trend event are displayed on screen by touching the Help switch. The Help switch is an alternate switch. Touching the Help switch again clears the display.

● Trend name

This is the name of the trend data per channel set on the smart object.

The trend name is displayed by touching the Help switch.

The trend name is displayed in the same text color as the trend graph.

- **Process variable**



The PV (process variable) for each channel is displayed as numeric value data.
The PV is displayed by touching the Help switch.
The PV is displayed at the same text color as the trend graph.



- **Event name**



This is the name of the event data per channel set on the smart object.
The event name is displayed by touching the Help switch.

- **Scroll keys**

These keys scroll the trend display.

  : Scroll the trend display to the start/final screen.

  : Scroll the trend display one screen at a time.

  : Scroll the trend display half a screen at a time.

■ Trend Menu Panel

The trend menu panel is displayed by touching the icon display area at the top right of the trend smart object for three seconds.

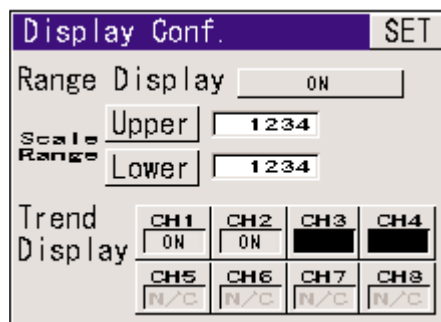

- **Range display**

This item controls display of the upper/lower limit values.

ON: Displays the upper/lower limit values.

OFF: Clears display of the upper/lower limit values.

- **Upper/lower limit**

This item changes the upper/lower limit values.

Touching a switch area displays a numeric keypad on which you can change the value.

● **Trend display**

This item controls display of trends on each channel.

ON: Displays the trend data.

OFF: Clears display of the trend data.

N/C: Unused channel

Trend display settings are the settings of a temporary display state.

Trend display settings are cleared when a panel is switched.

■ **Variable Trend Menu Panels**

The variable trend menu panel is displayed by touching the icon display area at the top right of the variable trend smart object for three seconds.

● **Device change switch**

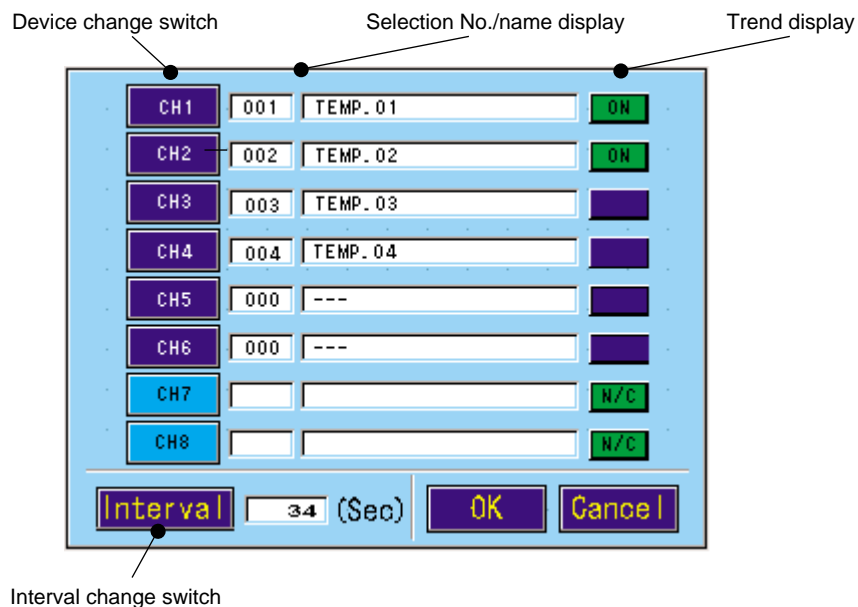

Touching this switch causes the [Device Selection Menu] to pop up, and you can change the sampling device for each channel.

The switch is not displayed for unused channels.

● **Selection No./name display**

This item displays the No. of the currently selected device and its name.

● **Trend display**

This item controls display of trends on each channel.

ON: Displays the trend data.

OFF: Clears display of the trend data.

N/C: Unused channel

Trend display settings are the settings of a temporary display state.

Trend display settings are cleared when a panel is switched.

- **Interval change switch**

Touching this switch causes the numeric keypad panel to pop up, and you can change the trend data sampling cycle.

- **Device selection menu**

This menu pops up and is displayed by touching the device change switch. This menu displays the name of selection devices set in the smart object paste parameters, and is used for changing the device to be sampled to the device of the selected name.

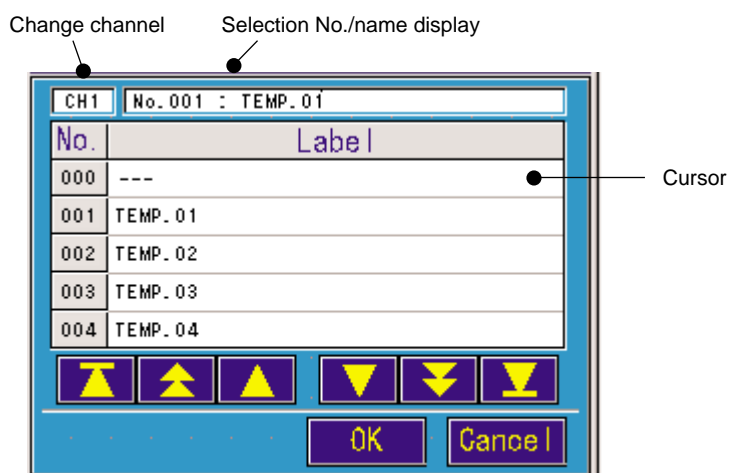

- **Change channel**

This item displays the channel to be changed.

- **Selection No./name display**

This item displays the current selection No. and trend name of the channel to be changed.

- **Cursor**

The trend devices to be changed are displayed in the cursor field. Select the trend device using the scroll key and apply the selection by the [OK] switch. When No.000 [- -] is selected, the trend of that channel is not sampled.

! Handling Precautions

When the trend sampling device or sampling cycle has been changed, all currently sampled trend data is cleared, and sampling of trend data is started at the newly selected settings.

Smart object name	Trend				
Type	Trend				
Scaling					Paste coordinates
Enlarge	Reduce	Reshape	Scaling factor	Text size	
			—	—	Any

■ Function

- This smart object samples the data of the word address specified by the sampling address at the sampling cycle and displays the sampled data as a trend.
- Trends for up to eight channels can be displayed.
- The ON/OFF states of bit devices can be displayed as events.
The bit data specified by the sampling address in the event settings is sampled at the sampling cycle and displayed as events.
- The events of up to three channels can be displayed.
- The sampled time is displayed on the X axis of the trend display in the format "month/day, hour:minute".
- 2-axis display can be set by adding the Y axis to the trend display.
In this display format, up to four channels can be displayed on a single axis of the trend display.
- Sampling start/end by PLC device or sampling start/end by time can be set for sampling of trend data.
- The trend menu panel can be called up to clear the display of each channel and change the minimum and maximum values of the display.
- Sampled data can be cleared by setting the Hide device to ON.

■ Configuration

● Basic

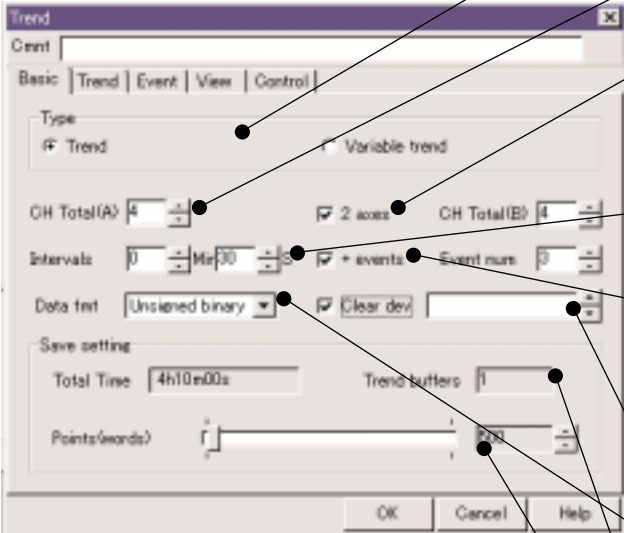

The screenshot shows the 'Trend' configuration dialog box with the following settings and callouts:

- [Type]**: This item is for selecting the type of trend smart object. (Callout points to the 'Type' section with 'Trend' selected.)
- [CH Total (A)]**: This item is for entering the number of channels to be displayed as a trend. (Callout points to the 'CH Total(A)' spinner set to 4.)
- [2 axes]**: This item is for configuration trend display to the 2-axis format. Enter the number of channels to be displayed on the two axes. (Callout points to the '2 axes' checkbox, which is checked.)
- [Intervals]**: This item is for entering the data sampling cycle. (Callout points to the 'Intervals' spinner set to 30.)
- [With events]**: This item is for setting sampling and display functions for the event data. Enter the number of event channels to be used. (Callout points to the '+ events' checkbox, which is checked.)
- [Clear device]**: This item is for entering the bit device for clearing the data. (Callout points to the 'Clear dev' text box.)
- [Data format]**: This item is for selecting the display data format of the trend data. (Callout points to the 'Data fmt' dropdown menu set to 'Unsigned binary'.)
- [Trend buffers]**: This item displays the number of trend buffers to be used on the smart object. (Callout points to the 'Trend buffers' spinner set to 1.)
- [Points (words)]**: This item is for entering the buffer size per channel. (Callout points to the 'Points(words)' spinner set to 1.)

- **CH Total (A)**
Enter the number of channels by which trends are to be sampled and displayed. The number of channels that can be sampled and displayed on a single smart object is 1 to 8.
Note, however, that the number of channels that can be displayed when 2-axis display format is selected is 1 to 4.
- **CH Total (B) (when 2-axis display is selected)**
Sampled data is displayed in the form of a 2-axis trend graph. Enter the number of channels to be displayed on the 2nd axis (B) axis. The number of channels that are displayed on the 2nd (B) axis is 1 to 4.
- **Intervals**
Enter the data sampling cycle within the range 1 second to 60 minutes 59 seconds.
- **Number of events (when with event is selected)**
Enter the number of channels by which event data is to be sampled and displayed.
The range of event channels that can be sampled and displayed on a single smart object is 1 to 3.
- **Clear device**
Enter the bit device on the PLC for forcibly clearing the sampled data.
- **Data format**
Select the display format of the sampled trend data from Unsigned binary/Signed binary/BCD.

- Trend buffers
The number of trend buffers to be used on the smart object is displayed.
- Points (words)
Set the size of the data to be saved for a single channel.
The data size can be set within the range 320 to 101400.
Note, however, that when a trend buffer exceeding this size cannot be secure to special storage area, a setting exceeding the upper limit value at that time is not possible.

● Trend

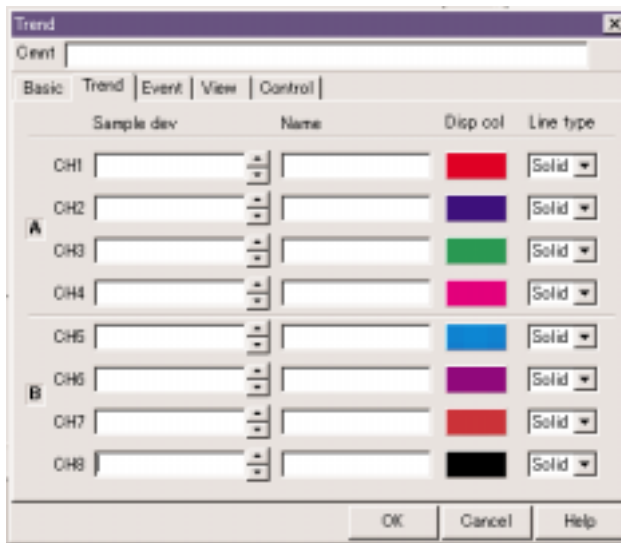

- [Sample device]
This item is for entering the word device to be sampled and saved.
- [Name]
This item is for entering the name of the trend data.
- [Display color]
This item is for selecting the display color of the trend graph.
- [Line type]
This item is for selecting the display line type of the trend graph.

- Sample device
Enter the word device whose trend is to be sampled. When the 2-axis display format is selected for the trend, channels 1 to 4 are displayed on the A axis and channels 5 to 8 are displayed on the B axis.
- Name
Enter the name of the data for each channel using up to 16 1-byte characters. The trend name is displayed by touching the Help switch for the trend smart object.
- Display color
Select the color of the line to be displayed on the trend graph. The trend name and the PV are also displayed using this color.

● Event

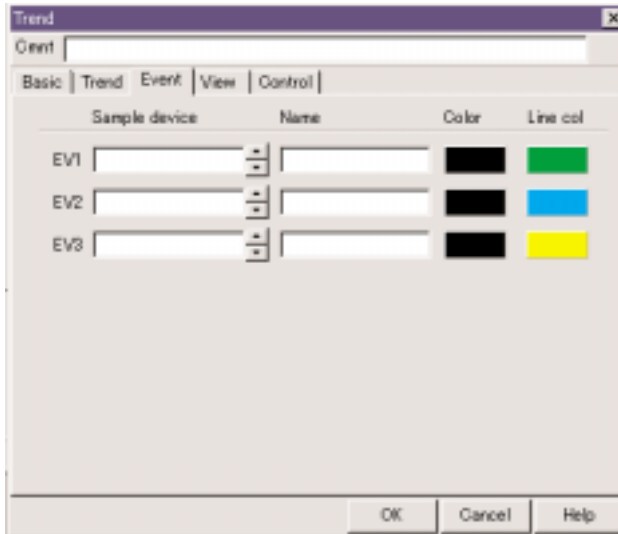

[Sample device]

This item is for entering the bit device to be sampled and saved.

[Name]

This item is for entering the name of the event data.

[Color]

This item is for selecting the display text color of the event name.

[Line color]

This item is for selecting the display color of the event graph.

- **Sample device**
Enter the bit device whose events are to be sampled.
- **Name**
Enter the event data name for each channel using up to 16 1-byte alphanumeric characters. The event name is displayed by touching the Help switch for the trend smart object.
- **Color**
Select the display text color of the event name.
- **Line color**
Select the display color of each event data.

● View

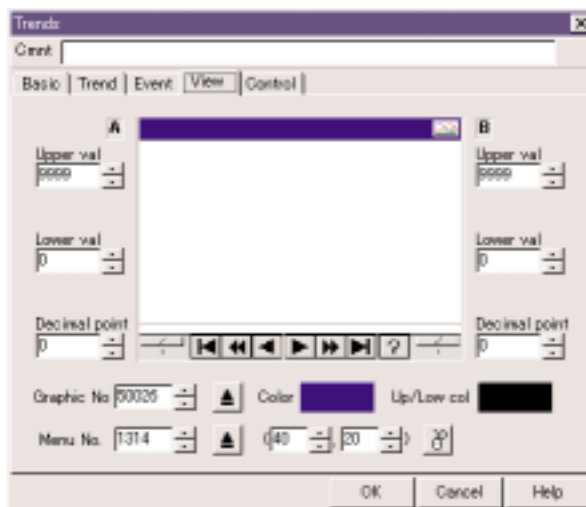

[Upper/lower value]

This item is for entering the upper/lower limit values of the Y axis.

[Decimal point]

This item is for entering the decimal point position of the upper/lower limit values on the Y axis.

[Graphical No.]

This item is for selecting the display graphic of the trend.

[Color]

This item is for selecting the display color of the trend graphic.

[Upper/lower color]

This item is for selecting the numeric display color of the upper/lower limit values.

[Menu No.]

This item is for entering the menu panel to call up and the call coordinates.

● Sampling control

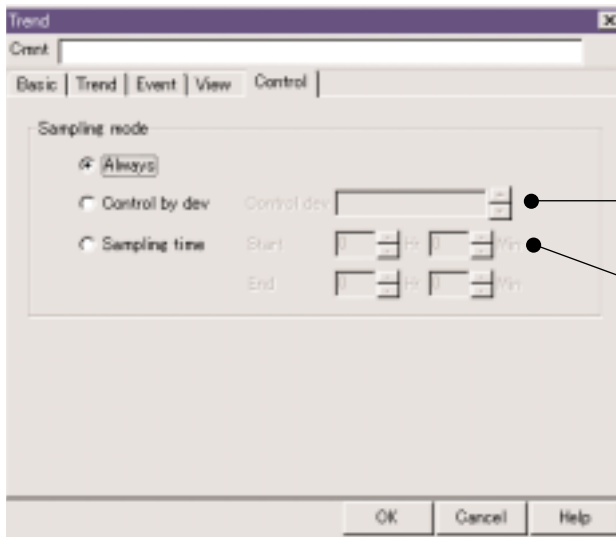

[Control device]
This item is for entering the start device for data sampling.

[Sampling time]
This item is for entering the start/end times of data sampling.

- Control device (when control by device is selected)
Start/end of sampling is controlled by bit device on the PLC.
Data is sampled and saved at the specified sampling cycle for the time that the control device is ON.
- Sampling mode (when sampling time is specified)
Specify the sampling start/end times.
Data is sampled and saved from the set start time up to the set end time.
Sampling of trend data is stopped when the end time is exceeded.

■ Example

Number of channels A = 4 (1CH = D000, 2CH = D001, 3CH = D003, 4CH = D004),
 number of events = 2 (1CH = M010, 2CH = M011), number of stores = 5000,
 number of trend buffers = 2, control by device, control device = M000

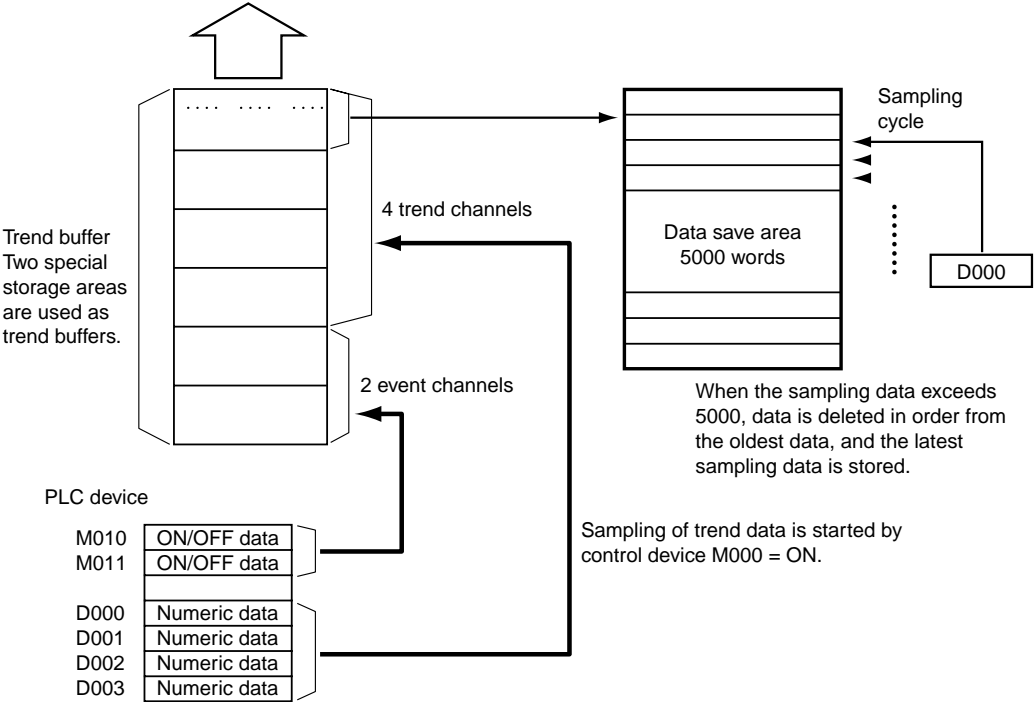
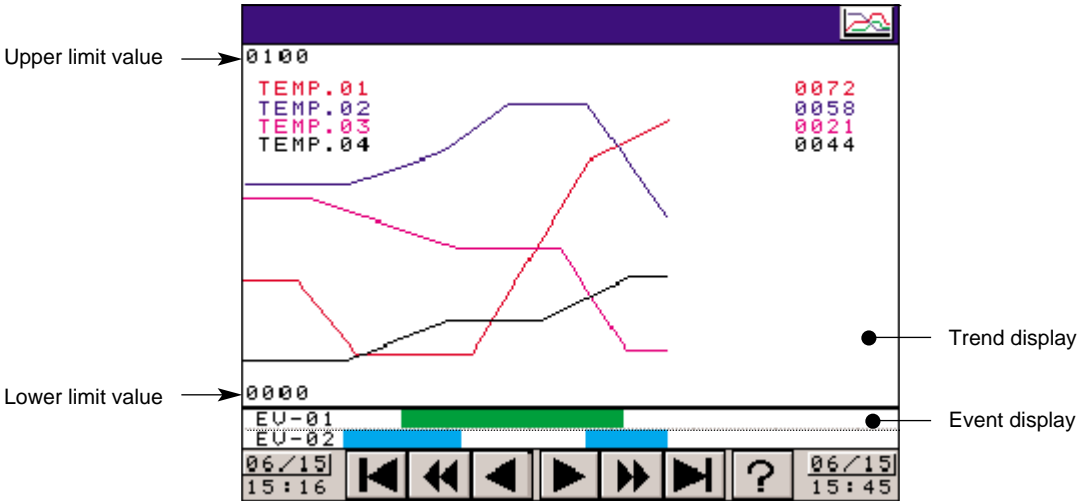

■ Smart Object Parameters

Tag name	Parameter name	Selection/setting item	Remarks
Basic	CH Total (A)	Enter the number of samples and display channels for the trend data. (When displaying by two axes, enter the number of channels on the A-axis.)	1 to 8 (1 to 4 in case of two axes)
	Intervals	Enter the sampling cycle of the data.	1s to 60min 59s
	Trend buffers	Display the number of trend buffers used in the special storage area.	Display only
	Points (words)	Enter the sample data size per channel.	320 to 101400
	Data format	Select the data format of the trend data from unsigned binary/signed binary/BCD.	
	Clear device	Enter the communications channel, the device address, and the bit device.	
	Number of events	Enter the number of samples and display channels for the event data.	When "with event" is selected
	CH Total (B)	Enter the number of channels on the B-axis.	When 2 axes is selected: 1 to 4
Trend	Sample device	Enter the communications channel, the device address, and the word device.	
	Display color	Select the display color of the trend graph for each channel.	
	Name	Enter the trend data name for each channel.	16 single-byte alphanumeric characters
	Line type	Select the display line type of the trend graph for each channel.	
Event	Sample device	Enter the communications channel, the device address, and the bit device.	
	Name	Enter the event data name for each channel.	16 single-byte alphanumeric characters
	Name Color	Enter the display text color of the event name.	
	Line color	Select the display color of event data.	
View	Upper value	Enter the display upper limit value of the trend data.	
	Lower value	Enter the display lower limit value of the trend data.	
	Decimal point	Enter the display decimal point position of the trend data.	
	Graphic No.	Select the display graphic.	
	Color	Select the display color of the graphic.	
	Upper/lower color	Select the display text color of the upper/lower limit values.	
	Menu No.	Enter the trend menu panel No.	1300 to 1319
	Coordinates	Enter the call coordinates of the trend menu panel.	
Control	Control device	Enter the communications channel, the device address, and the bit device.	
	Start	Enter the sampling start time of the trend data.	
	End	Enter the sampling end time of the trend data.	

■ Supplementary Explanation

- When sampling of trend data exceeds the data size of the trend buffer, data is deleted from the oldest data onwards and the latest data is stored.
- When sampling of trend data has been stopped and sampling resumed, "0" is set to the sampling data of the time during which sampling stopped and sampling of data is continued from the elapsed time.

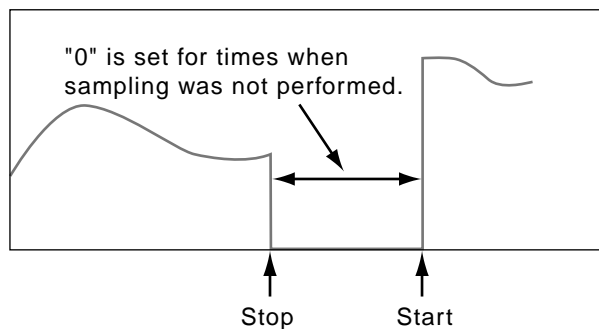

! Handling Precautions

- Be sure to enter a multiple of 16 when entering the bit device to the trend sampling address.
- Enter the bit device on the PLC as the sampling address for the event. Do not enter word devices such as registers.
- Enter 1-byte strings to the trend name. 2-byte strings cannot be displayed on the EST.
- Enter the bit device on the PLC at Hide device/Control device. Do not enter word devices such as registers.
- The Hide device is reset to OFF on the EST after the ON state of the bit is confirmed.
- Execute Hide device by one-shot instructions. One-shot instructions may not function properly on circuits that are executed at all times.

[Ladder circuit example]

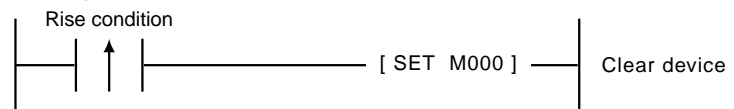

- At least one special storage area is used as a trend buffer for a single trend smart object.
The special storage area is used for recipe smart objects, trend smart objects and special packages. Trend smart objects cannot be used when all five special storage areas are used.
- If a short sampling cycle is set, data sometimes cannot be sampled at the set sampling cycle in some applications.
If data was not sampled at the set sampling cycle, the EST sets "0" to the sampling data.
At this time, internal special contact SM9068.0 is set to ON. During debugging of applications, determine the sampling cycle by monitoring SM9068.0 on a switch or lamp smart object.
Special contact SM9068.0 is a latch-operated contact, and can be reset by switch smart objects.

Smart object name	Variable trend					
Type	Trend					
	Scaling				Paste coordinates	
	Enlarge	Reduce	Reshape	Scaling factor		Text size
				—	—	Any

■ Function

- This smart object is for selecting the device to be sampled on the EST.
- Up to 40 devices can be set for the device to be selected.
- The data of the selected address is sampled and displayed as a trend.
- Trends for up to eight channels can be displayed.
- The ON/OFF states of bit devices can be displayed as events.
The bit data specified by the sampling address in the event settings is sampled at the sampling cycle and displayed as events.
- The events of up to three channels can be displayed.
- The sampled time is displayed on the X axis of the trend display in the format “month/day, hour:minute”.
- 2-axis display can be set by adding the Y axis to the trend display.
In this display format, up to four channels can be displayed on a single axis of the trend display.
- Sampling start/end by PLC device or sampling start/end by time can be set for sampling of trend data.
- The variable trend menu panel can be called to change the device on which the trend is to be sampled and the sampling cycle. Trend displays can also be cleared for each channel.
- Sampled data can be cleared by setting the Hide device to ON.

■ Configuration

● Basic

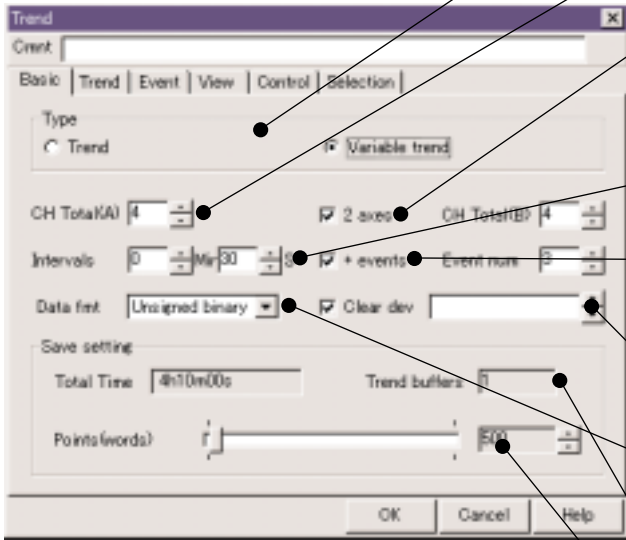

The screenshot shows the 'Trend' configuration dialog box with the following settings and callouts:

- [Type]**: Points to the 'Type' section where 'Trend' is selected.
- [CH Total (A)]**: Points to the 'CH Total(A)' spin box, set to 4.
- [2 axes]**: Points to the '2 axes' checkbox, which is checked.
- [Intervals]**: Points to the 'Intervals' spin box, set to 30 minutes.
- [With event]**: Points to the '+ events' checkbox, which is checked.
- [Clear device]**: Points to the 'Clear dev' spin box, set to X0.
- [Data format]**: Points to the 'Data fmt' dropdown menu, set to 'Unsigned binary'.
- [Trend buffers]**: Points to the 'Trend buffers' spin box, set to 7.
- [Points (words)]**: Points to the 'Points(words)' spin box, set to 1.

- **CH Total (A)**
Enter the number of channels by which trends are to be sampled and displayed. The number of channels that can be sampled and displayed on a single smart object is 1 to 8.
Note, however, that the number of channels that can be displayed when 2-axis display format is selected is 1 to 4.
- **CH Total (B) (when 2-axis display is selected)**
Sampled data is displayed in the form of a 2-axis trend graph. Enter the number of channels to be displayed on the 2nd axis (B) axis. The number of channels that are displayed on the 2nd (B) axis is 1 to 4.
- **Intervals**
Enter the data sampling cycle within the range 1 second to 60 minutes 59 seconds.
- **Number of events (when with event is selected)**
Enter the number of channels by which event data is to be sampled and displayed.
The range of event channels that can be sampled and displayed on a single smart object is 1 to 3.
- **Clear device**
Enter the bit device on the PLC for forcibly clearing the sampled data.
- **Data format**
Select the display format of the sampled trend data from Unsigned binary/Signed binary/BCD.

- Trend buffers
The number of trend buffers to be used on the smart object is displayed.
- Points (words)
Set the size of the data to be saved for a single channel.
The data size can be set within the range 320 to 101400.
Note, however, that when a trend buffer exceeding this size cannot be secure to special storage area, a setting exceeding the upper limit value at that time is not possible.

● Trend

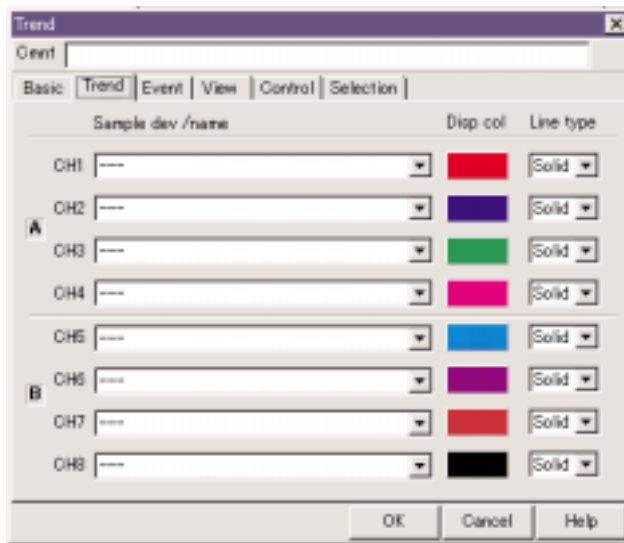

[Sample device/name]
This item is for selecting the word device to be sampled and saved when the application is downloaded.

[Display color]
This item is for selecting the display color of the trend graph.

[Line type]
This item is for selecting the display line type of the trend graph.

- Sample device/name
Select the word device from which trend samples after the application is downloaded.
Select from the data set at [Selection].
When 2-axis display is selected for trends, channels 1 to 4 are displayed on the A-axis and channels 5 to 8 are displayed on the B-axis.
- Display color
Select the color of the line to be displayed on the trend graph.
The trend name and the PV are also displayed using this color.

● Event

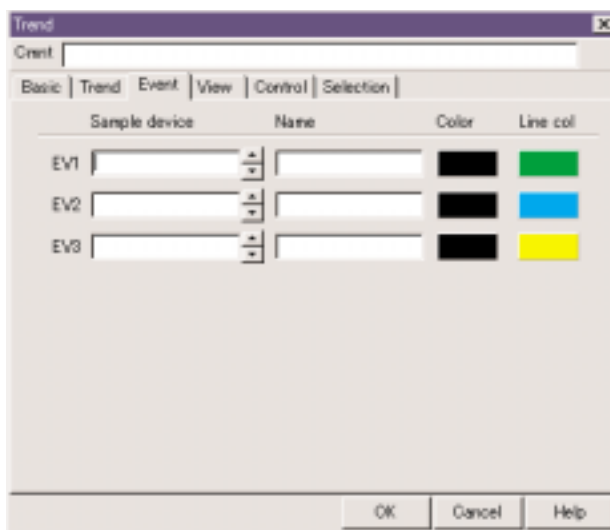

[Sample device]

This item is for entering the bit device to be sampled and saved.

[Name]

This item is for entering the name of the event data.

[Color]

This item is for selecting the display text color of the event name.

[Line color]

This item is for selecting the display color of the event graph.

- **Sample device**
Enter the bit device whose events are to be sampled.
- **Name**
Enter the event data name for each channel using up to 16 1-byte alphanumeric characters. The event name is displayed by touching the Help switch for the trend smart object.
- **Color**
Select the display text color of the event name.
- **Line color**
Select the display color of each event data.

● View

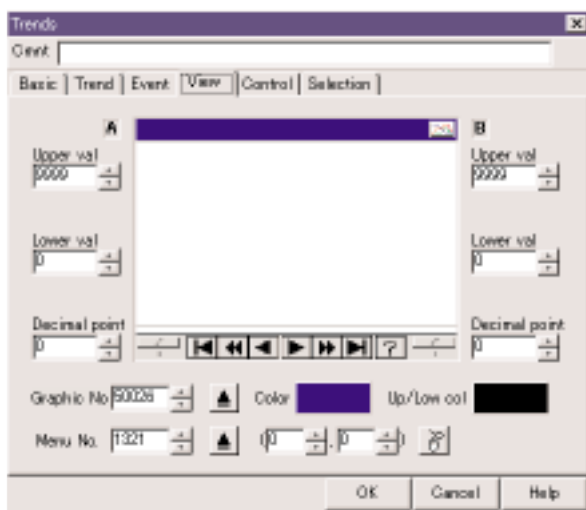

[Upper/lower value]

This item is for entering the upper/lower limit values of the Y axis.

[Decimal point]

This item is for entering the decimal point position of the upper/lower limit values on the Y axis.

[Graphic No.]

This item is for selecting the display graphic of the trend.

[Color]

This item is for selecting the display color of the trend graphic.

[Upper/lower color]

This item is for selecting the numeric display color of the upper/lower limit values.

[Menu No.]

This item is for entering the menu panel to call up and the call coordinates.

● Control

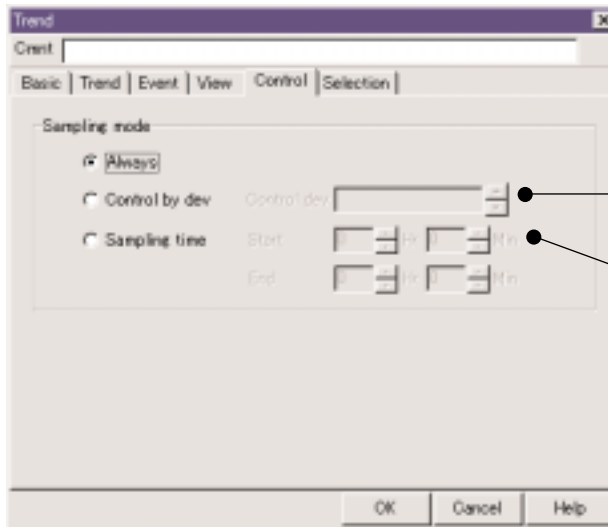

[Control device]
This item is for entering the start device for data sampling.

[Sampling time]
This item is for entering the start/end times of data sampling.

- Control device (when control by device is selected)
Start/end of sampling is controlled by bit device on the PLC.
Data is sampled and saved at the specified sampling cycle for the time that the control device is ON.
- Start/end (when sampling time is specified)
Specify the sampling start/end times.
Data is sampled and saved from the set start time up to the set end time.
Sampling of trend data is stopped when the end time is exceeded.

● Selection

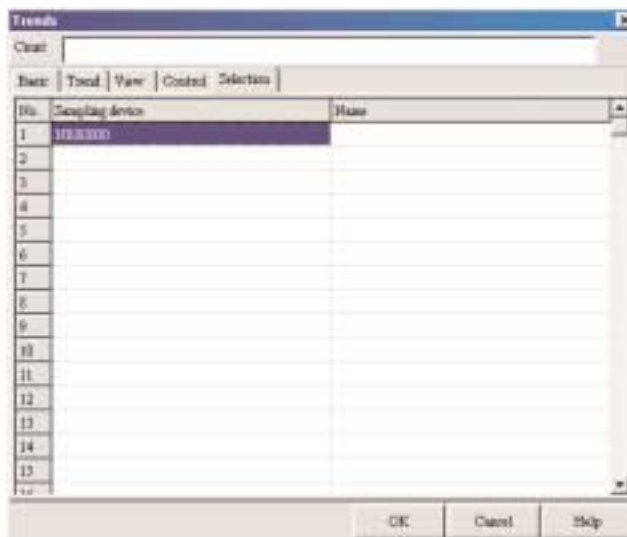

[Sample device]
This item is for entering the device whose data is to be sampled.

[Name]
This item is for entering the name of the data.

- Sample device
Up to 40 devices whose data is to be sampled can be set.
The data set here becomes the trend sampling device that can be changed on the EST.
- Name
Set the name of the device to be sampled using up to 16 1-byte characters.
To change the trend device, select the trend to be sampled from these names.
(On the EST, the name is displayed and the sampling device is not displayed.)

■ Example

To change the sampling device:

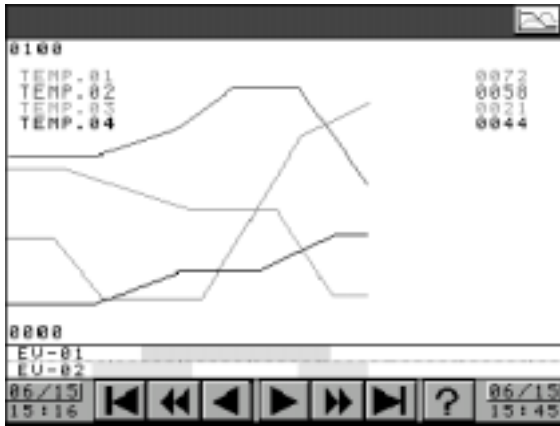

Touch the icon at the top right of the smart object for 3 seconds

[Selector Type Trend Menu Panel]

CH1	005	TEMP. 05	ON
CH2	006	TEMP. 06	ON
CH3	007	TEMP. 07	ON
CH4	008	TEMP. 08	ON
CH5	000	---	
CH6	000	---	
CH7			N/C
CH8			N/C

Interval 34 (Sec) OK Cancel

[Trend Selection Panel]

No.	Label
000	---
001	TEMP. 01
002	TEMP. 02
003	TEMP. 03
004	TEMP. 04

CH1 No. 001 : TEMP. 01

OK Cancel

Touch [OK] after changing the trend to be sampled



When the trend to be sampled of the sampling cycle has been changed, all trend data sampled so far will be cleared, and sampling of the data at the newly set trend settings will be started.

■ Smart Object Parameters

Tag name	Parameter name	Selection/setting item	Remarks
Basic	CH Total (A)	Enter the number of samples and display channels for the trend data. (When displaying by two axes, enter the number of channels on the A-axis.)	1 to 8 (1 to 4 in case of two axes)
	Intervals	Enter the sampling cycle of the data.	1s to 60min 59s
	Trend buffers	Display the number of trend buffers used in the special storage area.	Display only
	Points (words)	Enter the sample data size per channel.	320 to 101400
	Data format	Select the data format of the trend data from unsigned binary/signed binary/BCD.	
	Clear device	Enter the communications channel, the station address, and the bit device.	
	Number of events	Enter the number of samples and display channels for the event data.	When "with event" is selected
	CH Total (B)	Enter the number of channels on the B-axis.	When 2-axis display is selected: 1 to 4
Trend	Sample device	Enter the communications channel, the device address, and the word device.	
	Display color	Select the display color of the trend graph for each channel.	
	Name	Enter the trend data name for each channel.	16 single-byte alphanumeric characters
	Line type	Select the display line type of the trend graph for each channel.	
Event	Sample device	Enter the communications channel, the device address, and the bit device.	
	Name	Enter the event data name for each channel.	16 single-byte alphanumeric characters
	Color	Enter the display text color of the event name.	
	Line color	Select the display color of event data.	
View	Upper value	Enter the display upper limit value of the trend data.	
	Lower value	Enter the display lower limit value of the trend data.	
	Decimal point	Enter the display decimal point position of the trend data.	
	Graphic	Select the display graphic.	
	Color	Select the display color of the graphic.	
	Upper/lower color	Select the display text color of the upper/lower limit values.	
	Menu No.	Enter the trend menu panel No.	1320 to 1324
	Coordinates	Enter the call coordinates of the trend menu panel.	
Control	Control device	Enter the communications channel, the device address, and the bit device.	
	Start	Enter the sampling start time of the trend data.	
	End	Enter the sampling end time of the trend data.	
Selection	Sampling device	Enter the device to be sampled.	Max. 40
	Name	Enter the name of the sampling device.	

■ Supplementary Explanation

- When sampling of trend data exceeds the data size of the trend buffer, data is deleted from the oldest data onwards and the latest data is stored.
- When sampling of trend data has been stopped and sampling resumed, "0" is set to the sampling data of the time during which sampling stopped and sampling of data is continued from the elapsed time.

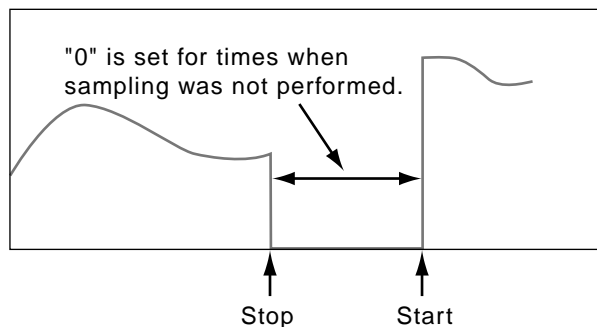

! Handling Precautions

- Be sure to enter a multiple of 16 when entering the bit device to the trend sampling address.
- Enter the bit device on the PLC as the sampling address for the event. Do not enter word devices such as registers.
- Enter the bit device on the PLC at Hide device/Control device. Do not enter word devices such as registers.
- The Hide device is reset to OFF on the EST after the ON state of the bit is confirmed.
- Execute Hide device by one-shot instructions. One-shot instructions may not function properly on circuits that are executed at all times.

[Ladder circuit example]

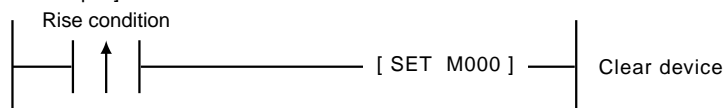

- At least one special storage area is used as a trend buffer for a single trend smart object.
The special storage area is used for recipe smart objects, trend smart objects and special packages. Trend smart objects cannot be used when all five special storage areas are used.
- If a short sampling cycle is set, data sometimes cannot be sampled at the set sampling cycle in some applications.
If data was not sampled at the set sampling cycle, the EST sets "0" to the sampling data.
At this time, internal special contact SM9068.0 is set to ON. During debugging of applications, determine the sampling cycle by monitoring SM9068.0 on a switch or lamp smart object.
Special contact SM9068.0 is a latch-operated contact, and can be reset by switch smart objects.
- New values after the upper/lower trend limit values, trend sample device and sampling cycle are changed are held in memory even after the EST power is reset.
- When the trend sampling device or sampling cycle has been changed, all currently sampled trend data is cleared.



4 - 4 Graphic Movement

Smart object name	Rail movement				
Type	Graphic Movement				
	Scaling				Paste coordinates
	Enlarge	Reduce	Reshape	Scaling factor	Text size
	<input type="radio"/>	<input type="radio"/>		Any	—
					Any

■ Function

- This smart object displays graphics at positions to be displayed at graphic positions.
- Rails have 12 point positions divided into 11 sections.
- Up to four graphics can be displayed on a single rail.
- registered graphics (64 x 64 dots) defined by the user are displayed as graphics.

■ Configuration

● Basic

[Type]
This item is for selecting the smart object type for graphic display.

[Rail]
This item is for selecting the display format of the rail.

[Number]
This item is for entering the number of graphics to be displayed.

[Graphic position]
This item is for entering the word device on the PLC to which the display position of the graphic is currently stored.

[Hide device]
This item is for entering the bit device whose graphic display is to be cleared.

- Rail
Select the display format for the rail.
Vertical: The rail is displayed in the vertical direction.
Horizontal: The rail is displayed in the horizontal direction.
- Number
Enter the number of graphics to be displayed simultaneously on the rail.

● Graphic

Set the graphic to be displayed on the smart object.

■ Example

Rail direction = vertical, number of graphics = 2, graphic 1 position = D010, graphic 2 position = D011, graphic 1 = 5, graphic 2 = 6

EST display

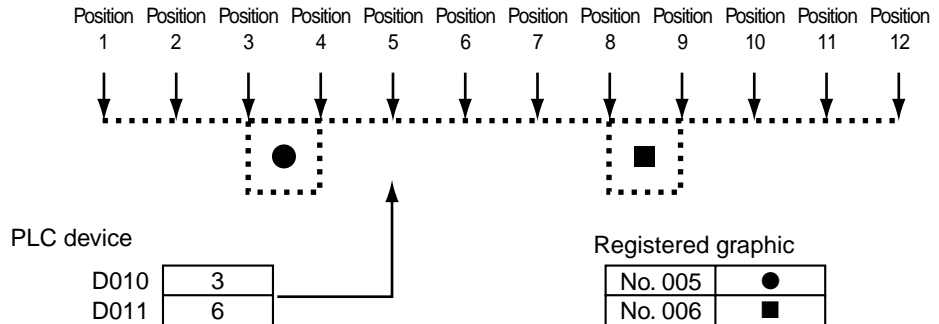

■ Smart Object Parameters

Tag name	Parameter name	Selection/setting item	Remarks
Basic	Rail	Select the display format of the rail from vertical/horizontal.	
	Number	Enter the number of graphics to be displayed on the rail.	1 to 4
	Graphic 1 position	Enter the communications channel, the device address, and the word device.	
	Graphic 2 position	Enter the communications channel, the device address, and the word device.	
	Graphic 3 position	Enter the communications channel, the device address, and the word device.	
	Graphic 4 position	Enter the communications channel, the device address, and the word device.	
	Hide device	Enter the communications channel, the device address, and the bit device.	
Graphic	Graphic type	Select user.	
	Graphic 1	Select the display graphic of graphic 1.	
	Graphic 2	Select the display graphic of graphic 2.	
	Graphic 3	Select the display graphic of graphic 3.	
	Graphic 4	Select the display graphic of graphic 4.	

■ Supplementary Explanation

- The range in which the top left of the graphic moves is displayed as the size of the smart object.
- For details on smart object settings, see “2-2 Main Configuration Items for Smart Objects” (page 2-5).

! Handling Precautions

- Be sure to enter a multiple of 16 when entering the bit device to Graphic position.
- Set binary data within the range 1 to 12 as the graphic position data. Graphics are not displayed when 0 is set as the position data. When position data is set to 12 or more, graphics are displayed at display position 12.
- The interval between graphic display positions on rail movement smart objects is fixed to equal intervals and cannot be changed.
- Create registered graphics at a size of 64 x 64 dots or smaller. registered graphics may not be displayed properly if they are created at a larger size.
- If graphic position data to be displayed on rail overlaps, the position data having the larger graphic position No. will be displayed on top.

Smart object name	Free movement					
Type	Graphic Movement					
	Scaling				Paste coordinates	
	Enlarge	Reduce	Reshape	Scaling factor		Text size
				Any	—	Any

■ **Function**

- This smart object displays specified graphics at the coordinates set by graphic positions X and Y on the PLC.
- The display angle of the graphic can be changed by selecting Display angle setting.
- The graphic to be displayed can be changed on the PLC.
- registered graphics defined by the user are displayed as graphics.

■ **Configuration**

● **Basic**

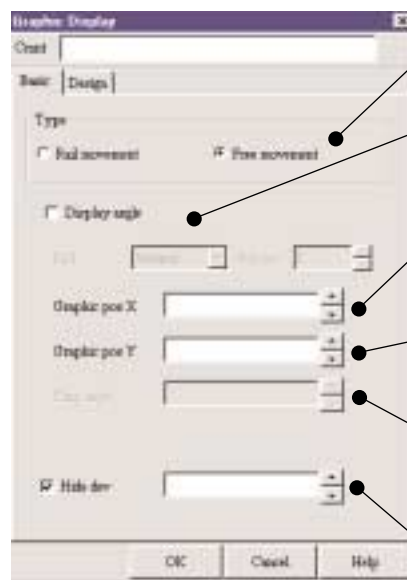

[Type]
This item is for selecting the smart object type for graphic display.

[Display angle]
Select this item to set the graphic display angle.

[Graphic position X]
This item is for selecting the word device on the PLC whose graphic display X coordinate is to be set.

[Graphic position Y]
This item is for selecting the word device on the PLC whose graphic display Y coordinate is to be set.

[Display angle]
This item is for entering the word device on the PLC whose graphic display angle is to be set.

[Hide device]
This item is for entering the bit device whose graphic display is to be cleared.

- **Graphic position X**
Specify the X coordinate where the graphic is to be displayed.
- **Graphic position Y**
Specify the Y coordinate where the graphic is to be displayed.
- **Display angle**
Specify the angle of rotation of the display graphic.

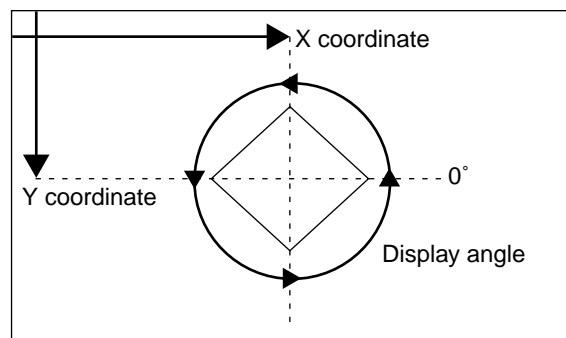

● Graphic

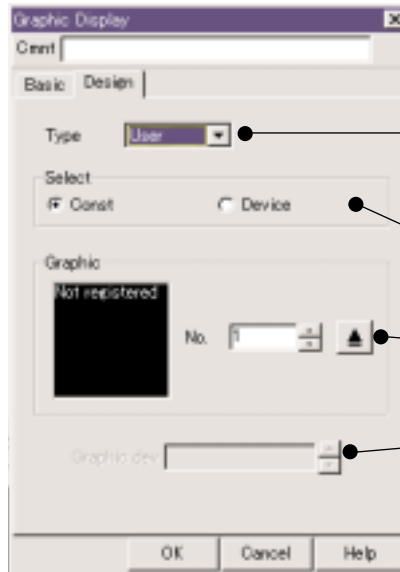

- [Type] This item is for setting the type of graphic to be displayed on the smart object.
- [Select] This item is for selecting how the graphic is to be specified.
- [Graphic] This item is for entering the graphic No. to be displayed.
- [Graphic device] This item is for entering the word device on the PLC to which the graphic No. to display is currently stored.

• Select

Select how the graphic is to be specified.

Constant: Enter the registered graphic No. to be displayed.

The display graphic is a specified fixed graphic.

Device: Specify the graphic to be displayed by a word device on the PLC.

The registered graphic of the graphic data (1 to 999) set to Graphic device is displayed.

■ Example

Graphic position X = D100, graphic position Y = D101, display angle = D102, graphic specification = device, graphic device = D110

EST display

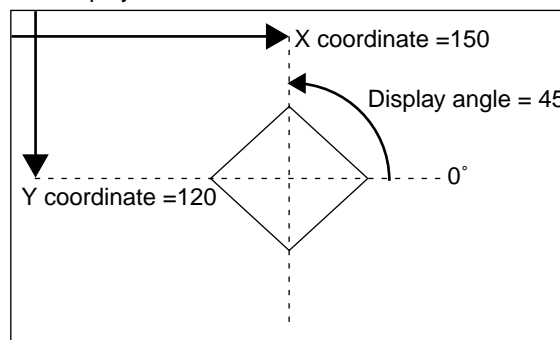

Registered graphic

Graphic No. = 5:



PLC device

D100	160	: Graphic position X
D101	120	: Graphic position Y
D102	45	: Display angle
D110	5	: Graphic device

■ Smart Object Parameters

Tag name	Parameter name	Selection/setting item	Remarks
Basic	Display angle	Select when the display angle setting is used.	
	Graphic position X	Enter the communications channel, the device address, and the word device.	0 to 319
	Graphic position Y	Enter the communications channel, the device address, and the word device.	0 to 239
	Display angle	Enter the communications channel, the device address, and the word device.	0 to 360
	Hide device	Enter the communications channel, the device address, and the bit device.	
Graphic	Type	Select user.	
	Select	Select the graphic designation method from constant/device.	
	Graphic	Select the display graphic.	Select: constant is selected
	Graphic device	Enter the communications channel, the device address, and the word device.	Select: device is selected

■ Supplementary Explanation

- Only functions are pasted. Anywhere is acceptable as the past position.
- The size of the registered graphic to be displayed is unlimited.
- Specify the display coordinates of the graphic center as the graphic's display position.

! Handling Precautions

- Be sure to enter a multiple of 16 when entering the bit device to Graphic display X/Y, Display angle and Graphic device.
- When rotating a graphic, do not set the background color of the registered graphic to transparent. Doing so will prevent normal rotation.
- Set the data of Graphic display X/Y and Display angle in binary within the following ranges:
 - Graphic position X: 0 to horizontal size of panel –1
 - Graphic position Y: 0 to vertical size of panel –1
 - Display angle: 0 to 360

When the specified coordinates are out of the panel range, the graphic will be displayed inside the nearest panel.
Display angles exceeding 360 will be displayed as 0.
- Enter the bit device on the PLC as the Hide device. Do not enter word devices such as registers.



Chapter 5. SYSTEM PANELS

5 - 1 Conventions Used In System Panel Specifications

■ System Panels

System panels are special panels that are called up from specific smart objects.

System panels are started up by simply pasting a smart object that calls up a system panel on top of a panel in the application data.

System panels cannot be called up directly from the user application, for example, by a panel change switch smart object.

■ List of System Panels

Category	Panel No.	Panel name	See page
Numeric keypad	—	Numeric keypad	5-4
Keyboard	—	Keyboard	5-8
Clock	1205	Clock correction	5-10
Message	1215	Message (16 x 5)	5-12
	1216	Message (32 x 5)	
	1217	Message (36 x 11)	
Alarm message	1245	Alarm message (16 x 4)	5-14
	1246	Alarm message (32 x 2)	
Trend	1301	Trend menu: 1-axis BCD	5-16
	1304	Trend menu: 1-axis unsigned binary	
	1307	Trend menu: 1-axis signed binary	
	1311	Trend menu: 2-axis BCD	
	1314	Trend menu: 2-axis unsigned binary	
	1317	Trend menu: 2-axis signed binary	
	1321	Variable trend menu	
1326	Trend device select menu		
Recipe	1345	Recipe data display	5-21
	1355	Recipe data editor	5-23

Basic Layout of Specification Descriptions

The following conventions are used in descriptions of each system panel.
 The following items describe each of the items in these specification descriptions.

Chapter 5. SYSTEM PANELS

5 - 5 Messages

Panel classification	Message	Panel No.	1210 to 1215
----------------------	---------	-----------	--------------

■ **Function**

- This panel is activated to pop-up by message call smart objects on string displays.
- Messages display the registered strings of No. set in the smart object parameters of message call smart objects.
- Touching the [Close] key closes the panel, and returns to the state before the message panel was called.

■ **Example**

■ **Supplementary Explanation**

- Registered strings are set during registered string editing on AP Editor. For details, see the Smart Terminal EST240Z User's Manual Application Preparation Manual No.CP-SP-1088E.

■ **Panel Shapes**

Message (16 x 5)	Panel No. 1215
Panel size 220 x 120	Remarks: Registered string data 16 single-byte characters x 5 lines

5-12

Names of system panel group

Function

Example

Supplementary explanation

System panel configuration

■ **Names of System Panel Types**

This item shows the name of system panel types.

■ **Function**

This item describes the functions of system panels.

■ **Example**

This item provides examples of how the system panel operates using certain settings as an example.

■ **Supplementary Explanation**

This item provides supplementary explanations for functions and method of use.

■ **Panel Shapes**

This item provides the shape and size of system panels.

5 - 2 Numeric Keypad

Panel classification	Numeric keypad	Panel No.	—
----------------------	----------------	-----------	---

■ Function

- This panel pops up and is displayed by numeric indicator smart objects or keyboard call smart objects.
- When the numeric keypad is displayed and the [ENT] key is touched after the data is set, that data is written to the specified device and the panel closes.
- When the data entered on the numeric keypad exceeds the upper or lower limit values when the [ENT] key is touched, a short, high-pitched alarm buzzers, and the entered data is cleared to “0”.

At this time, writing of the data is not performed and the panel does not close.

■ Example

- Calling a numeric keypad panel by a numeric indicator smart object
 Numeric keypad use ON, numeric device = D100, number of digits = 4, decimal point position = 1, write device = D100, numeric keypad input upper limit value = 1500, numeric keypad input lower limit value = 100

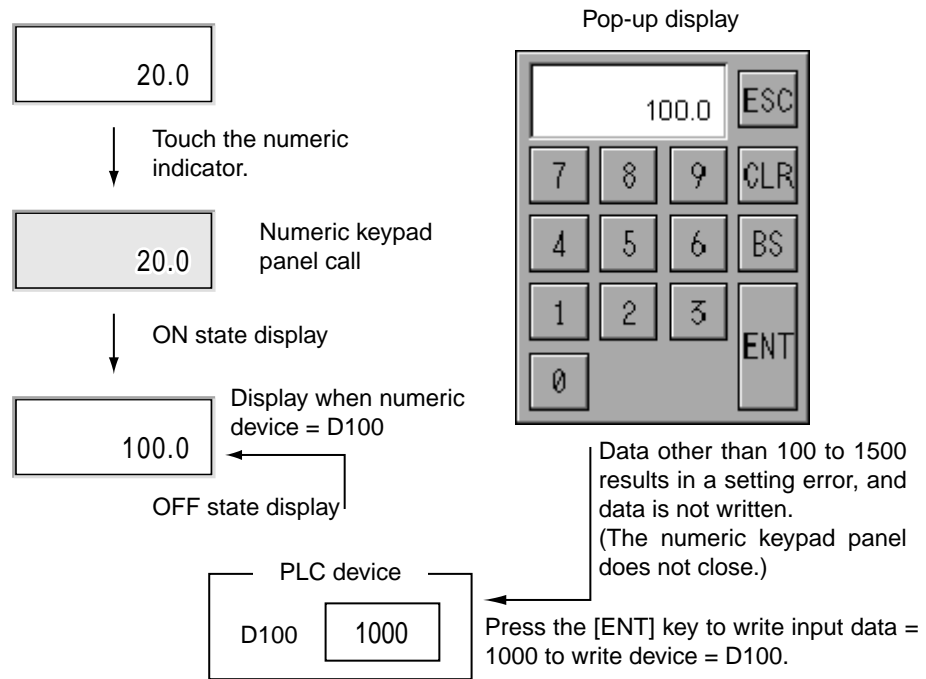

■ Supplementary Explanation

In the case of numeric keypads with a decimal point key, data beyond the decimal point is discarded before operations when the [ENT] key is touched when an input is made that exceeds the decimal point position set on that smart object.

When "10.1234" is set by numeric keypad input when the decimal point position = 2, the data from the third digit past the decimal point onwards is discarded and the entry operates as "10.12".

■ Panel Shapes

Binary unsigned numeric keypad (without decimal point key)	
	
Panel size	Remarks:
140 x 180	

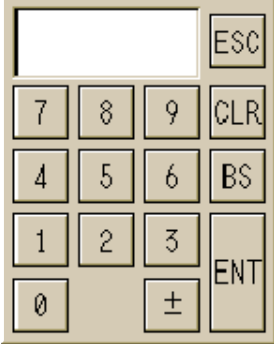
Binary signed numeric keypad (without decimal point key)	
	
Panel size	Remarks:
140 x 180	

BCD numeric keypad (without decimal point key)	
	
Panel size	Remarks:
140 x 180	

Hexadecimal numeric keypad (without decimal point key)	
Panel size	Remarks:
140 x 220	

Binary unsigned numeric keypad (with decimal point key)	
Panel size	Remarks:
140 x 180	

Binary signed numeric keypad (with decimal point key)	
Panel size	Remarks:
140 x 180	

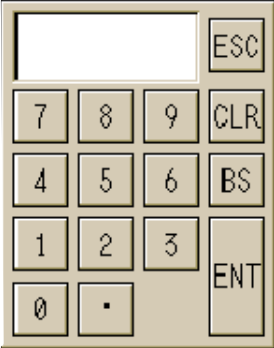
BCD numeric keypad (with decimal point key)	
	
Panel size	Remarks:
140 x 180	

Hexadecimal numeric keypad (with decimal point key)	
	
Panel size	Remarks:
140 x 220	

5 - 3 Keyboard

Panel classification	Keyboard	Panel No.	—
----------------------	----------	-----------	---

■ Function

- This panel is activated to pop-up by string display smart objects or keyboard call smart objects.
- On the keyboard panel, up to 64 characters for strings can be written to the word device of the PLC.
- Touching the [ENT] key writes the entered string to the PLC word device, closes the panel and returns to the state before the keyboard panel is called.

■ Example

- Keyboard use ON and string device = D100 when the keyboard panel is called by string display smart objects

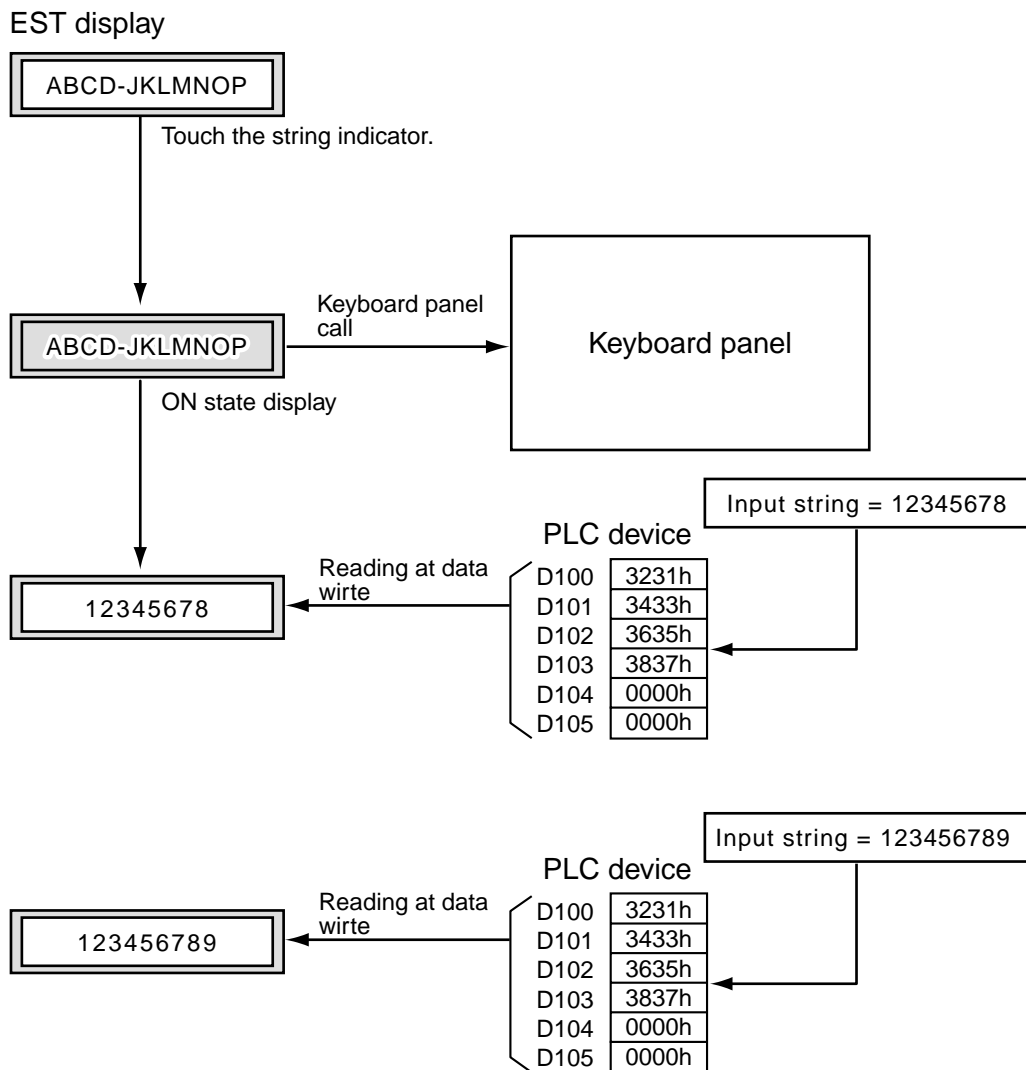

■ **Supplementary Explanation**

- When the number of entered characters on the keyboard panel are less than the number of characters to be called from the PLC, "00 Hex" is written to areas to which strings are not entered.
"00 Hex" is not written when the number of characters entered on the keyboard panel is the same as the number of characters to be called from the PLC.

■ **Panel Shapes**

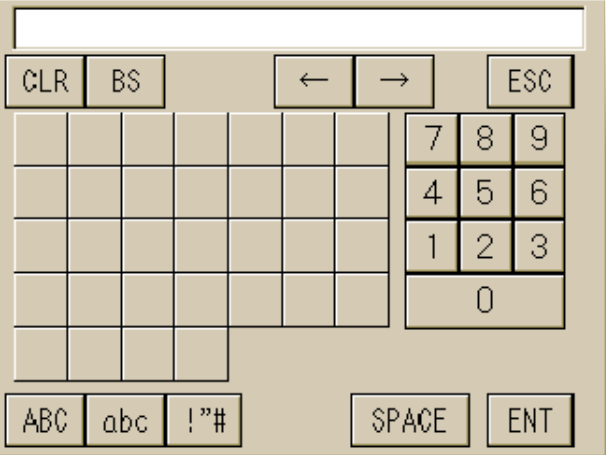
Keyboard	
	
Panel size	Remarks:
320 x 240	

5 - 4 Clock Correction

Panel classification	Clock correction	Panel No.	1200 to 1202
-----------------------------	------------------	------------------	--------------

■ Function

- This panel is activated to pop-up by clock setting call smart objects on function switches.
- On the clock correction panel, the built-in clock of the EST can be corrected.
- Numeric values can be changed by touching the top and bottom keys of the “Month/Date/Year” or “Hour/Minute/Second” display are touched. While numeric values are being changed, the numbers blink. The currently displayed “Month/Date/Year” or “Hour/Minute/Second” values are written to the built-in clock by touching the [Adjust] key.
- “Days” of a week are automatically displayed after being calculated them from “Month/Date/Year”.
- Touching the [Close] key closes the panel, and returns to the state before the clock correction panel was called.

■ Example

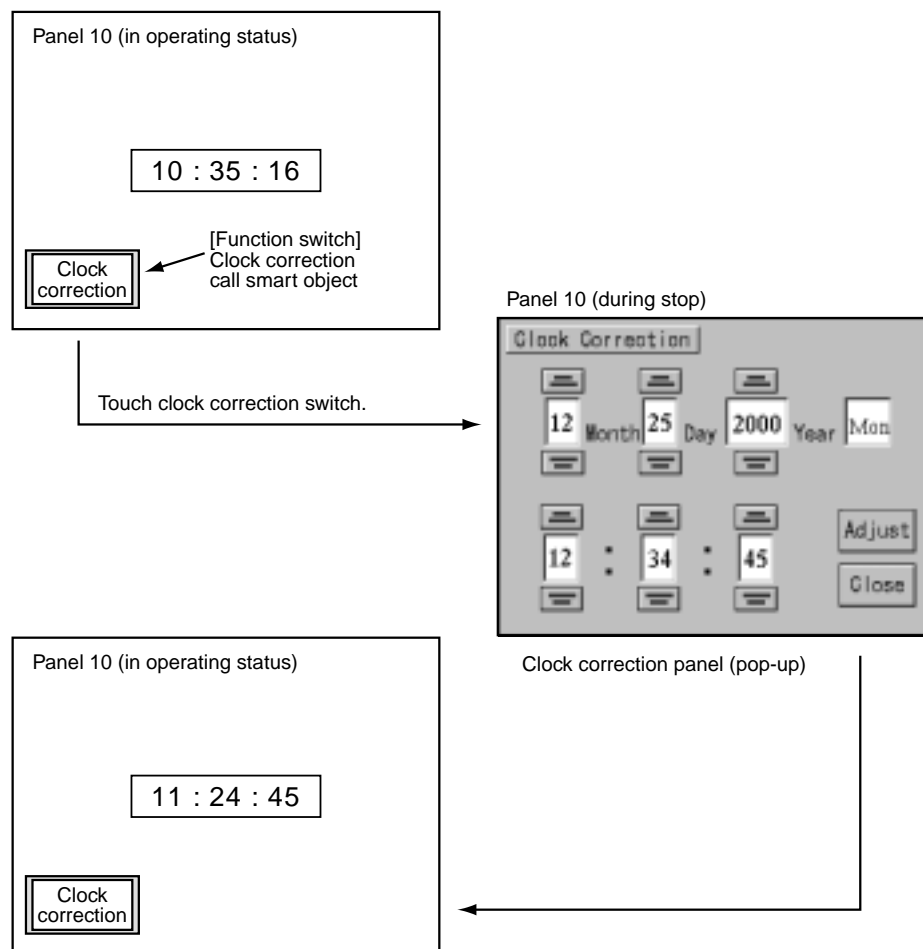

■ **Supplementary Explanation**

- If the date is changed to a non-existent date such as February 31, it cannot be written to the EST clock.

■ **Panel Shapes**

Clock correction		Panel No. 1205														
<div style="border: 1px solid black; padding: 10px; width: fit-content; margin: auto;"><p>Clock Correction</p><table style="width: 100%; border-collapse: collapse;"><tr><td style="text-align: center;"><input type="text"/></td><td style="text-align: center;">Month</td><td style="text-align: center;"><input type="text"/></td><td style="text-align: center;">Day</td><td style="text-align: center;"><input type="text"/></td><td style="text-align: center;">Year</td><td style="text-align: center;"><input type="text"/></td></tr><tr><td style="text-align: center;">:</td><td></td><td style="text-align: center;">:</td><td></td><td style="text-align: center;">:</td><td></td><td style="text-align: center;">:</td></tr></table><p style="text-align: right;"><input type="button" value="Adjust"/> <input type="button" value="Close"/></p></div>			<input type="text"/>	Month	<input type="text"/>	Day	<input type="text"/>	Year	<input type="text"/>	:		:		:		:
<input type="text"/>	Month	<input type="text"/>	Day	<input type="text"/>	Year	<input type="text"/>										
:		:		:		:										
Panel size	Remarks:															
320 x 240																

5 - 5 Messages

Panel classification	Message	Panel No.	1210 to 1215
----------------------	---------	-----------	--------------

■ Function

- This panel is activated to pop-up by message call smart objects on string displays.
- Messages display the registered strings of No. set in the smart object parameters of message call smart objects.
- Touching the [Close] key closes the panel, and returns to the state before the message panel was called.

■ Example

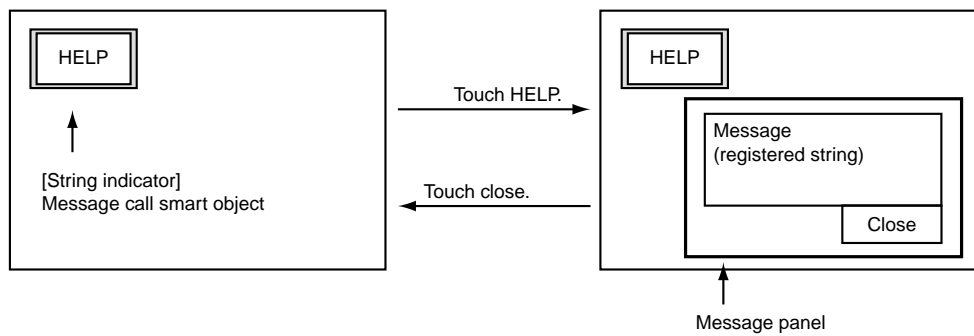

■ Supplementary Explanation

- Registered strings are set during registered string editing on AP Editor. For details, see the Smart Terminal EST240Z User's Manual Application Preparation Manual No.CP-SP-1088E.

■ Panel Shapes

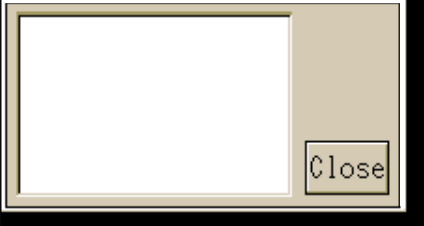
Message (16 x 5)		Panel No. 1215
		
Panel size	Remarks: Registered string data 16 single-byte characters x 5 lines	
220 x 120		

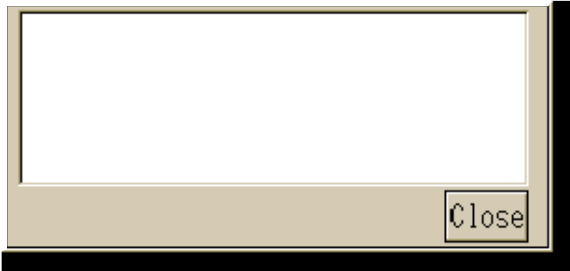
Message (32 x 5)		Panel No. 1216
		
Panel size	Remarks: Registered string data 32 single-byte characters x 5 lines	
300 x 140		

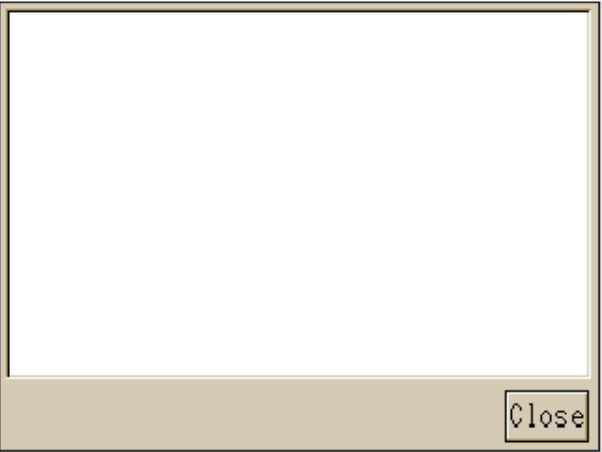
Message (36 x 11)		Panel No. 1217
		
Panel size	Remarks: Registered string data 36 single-byte characters x 11 lines	
320 x 240		

5 - 6 Alarm Messages

Panel classification	Alarm message	Panel No.	1240 to 1249
-----------------------------	---------------	------------------	--------------

■ Function

- This panel is activated to pop-up by touching aggregate lamp smart objects on alarm monitors. The corresponding alarm names and alarm messages will be displayed.
- Touching the [Close] key closes the panel, and returns to the state before the alarm message panel was opened.

■ Example

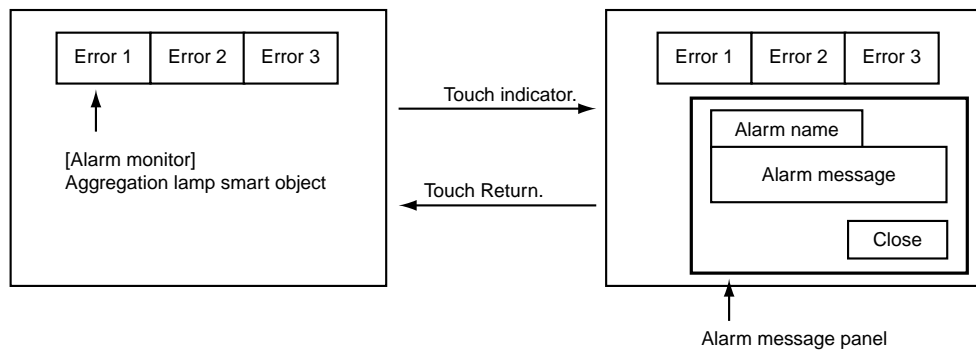

■ Supplementary Explanation

- Alarm monitor contacts, alarm names and alarm messages are registered during alarm monitor information editing on AP Editor. For details, see the Smart Terminal EST240Z User's Manual Application Preparation Manual No.CP-SP-1088E.

■ Panel Shapes

Alarm message (16 x 4)		Panel No. 1245
		
Panel size	Remarks: Alarm name 16 characters x 1 line, Alarm message 16 characters x 4 lines	
220 x 120		

Alarm message (32 x 2)		Panel No. 1246
		
Panel size	Remarks: Alarm name 16 characters x 1 line, Alarm message 32 characters x 2 lines	
300 x 100		

5 - 7 Trend Menus

Panel classification	Trend menu	Panel No.	1300 to 1319
----------------------	------------	-----------	--------------

■ Function

- This panel is activated to pop-up by touching the icon display field on trend smart objects for three seconds or more.
- The upper and lower limit values of trend displays can be changed.
- Display/non-display of trends can be set to each channel.
- Touching the [SET] key closes the panel, and returns to the state before the menu panel was called.

■ Example

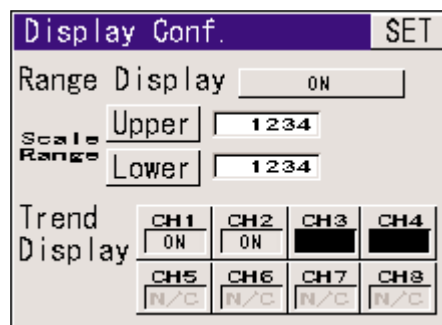

- Range display
This item controls display of the upper/lower limit values.
ON: Displays the upper/lower limit values.
OFF: Clears display of the upper/lower limit values.
- Upper/lower
This item changes the upper/lower limit values.
Touching a switch area displays a numeric keypad on which you can change the value.
- Trend display
This item controls display of trends on each channel.
ON: Displays the trend data.
OFF: Clears display of the trend data.
N/C: Unused channel

■ Supplementary Explanation

- New values after the upper/lower value displays and upper/lower limit value settings are changed are held in memory until the EST is reset.
- Trend display settings are the settings of a temporary display state. Trend display settings are cleared when a panel is switched.

■ Panel Shapes

Trend menu: 1-axis BCD		Panel No. 1301
Panel size	Remarks: 1-axis unsigned binary (panel No. 1304) and 1-axis signed binary (panel No. 1307) are also the same shape.	
220 x 160		

Trend menu: 2-axis BCD		Panel No. 1311
Panel size	Remarks: 2-axis unsigned binary (panel No. 1314) and 2-axis signed binary (panel No. 1317) are also the same shape.	
240 x 200		

Panel classification	Variable trend menu	Panel No.	1320 to 1324
-----------------------------	---------------------	------------------	--------------

■ **Function**

- This panel is displayed by touching the icon display field on a variable trend smart object for three seconds or more.
- The trend device to be sampled by each channel can be changed.
- The sampling cycle of the trend data can be changed.
- Touching the [OK] key closes the panel, and returns to the state before the menu panel was called.

■ **Example**

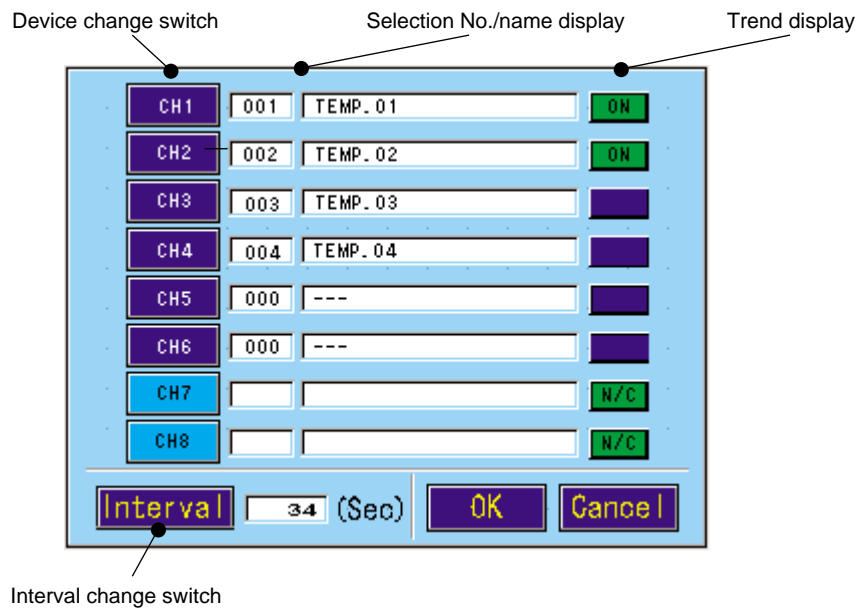

- **Device change switch**
Touching this switch causes the [Device Selection Menu] to pop up, and you can change the sampling device for each channel. The switch is not displayed for unused channels.
- **Selection No./name display**
This item displays the No. of the currently selected device and its name.
- **Trend display**
This item controls display of trends on each channel.
ON: Displays the trend data.
OFF: Clears display of the trend data.
N/C: Unused channel
- **Interval change switch**
Touching this switch causes the numeric keypad panel to pop up, and you can change the trend data sampling cycle.

- Device selection menu

This menu pops up and is displayed by touching the device change switch.

This menu displays the name of selection devices set in the smart object paste parameters, and is used for changing the device to be sampled to the device of the selected name.

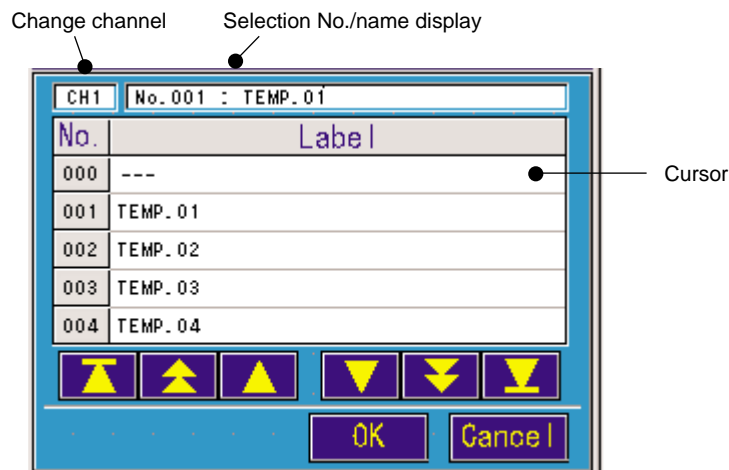

- Change channel

This item displays the channel to be changed.

- Selection No./name display

This item displays the current selection No. and trend name of the channel to be changed.

- Cursor

The trend devices to be changed are displayed in the cursor field. Select the trend device using the scroll key and apply the selection by the [OK] switch. When No.000 [---] is selected, the trend of that channel is not sampled.

■ Supplementary Explanation

- New values after the upper/lower trend limit values, trend sampling device and sampling cycle are changed are held in memory even after the EST is reset.
- Trend display settings are the settings of a temporary display state. Trend display settings are cleared when a panel is switched.

! Handling Precautions

When the trend sampling device or sampling cycle has been changed, all currently sampled trend data is cleared, and sampling of trend data is started at the newly selected settings.

■ Panel Shapes

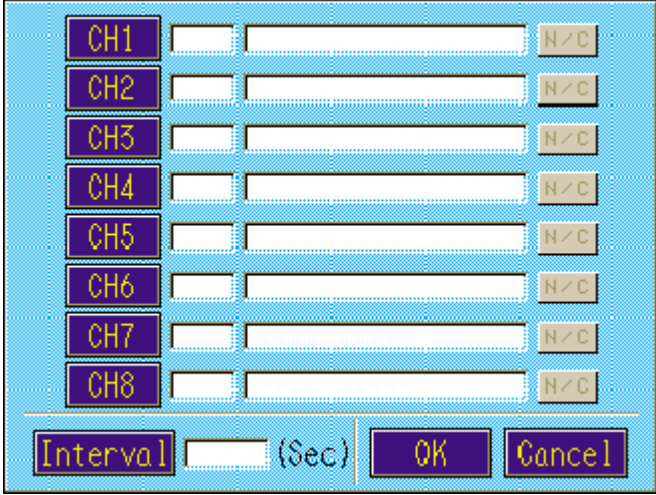
Variable trend menu	Panel No. 1321
	
Panel size	Remarks:
320 x 240	

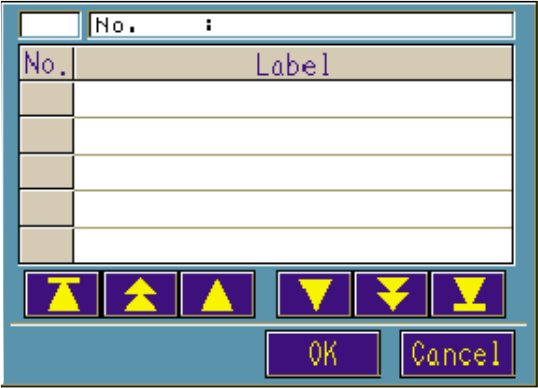
Device selection menu	Panel No. 1326
	
Panel size	Remarks:
280 x 200	

5 - 8 Recipe Menus

Panel classification	Recipe read panel	Panel No.	1340 to 1349
-----------------------------	-------------------	------------------	--------------

■ Function

- This panel pops up and is displayed by touching the [Select] switch on a recipe smart object.
- This panel is for selecting the recipe to be displayed on recipe smart objects.
- Touching the [Load] key calls the data of the selected recipe No. to the smart object. At this time, the panel closes and returns to the state before the menu panel was called.
- Touching the [Close] key closes the panel, and returns to the state before the menu panel was called.

■ Example

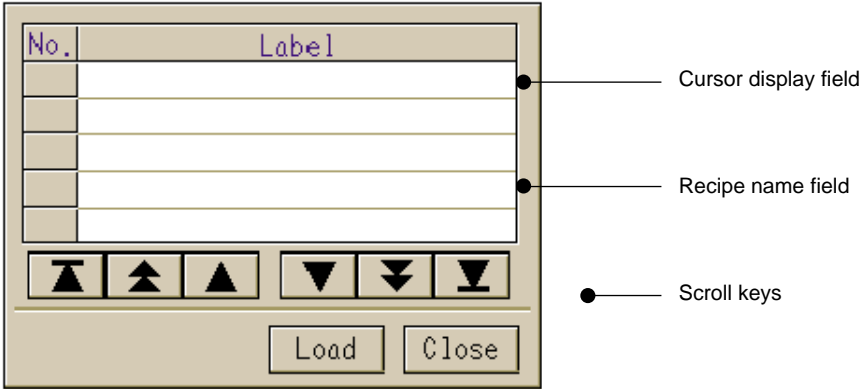

- **Load**
This buttons reads the data of the recipe No. in the cursor display field.
- **Close**
This button cancels the selection and returns to the call panel.
- **Recipe name field**
This item displays the name of the currently set recipe using up to 36 1-byte characters.
- **Scroll keys**
These keys scroll the data to be displayed.

- : Display the start/final data.
- : Scroll display data five items at a time.
Holding down these switches scrolls the display data at high speed.
- : Scroll display data one item at a time.
Holding down these switches scrolls the display data at high speed.

■ Panel Shapes

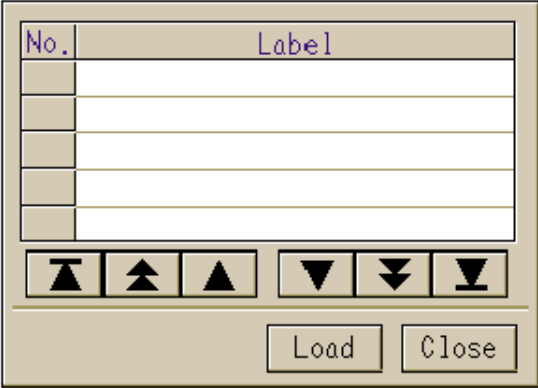
Recipe read panel		Panel No. 1345
		
Panel size	Remarks:	
280 x 200		

Panel classification	Recipe edit panel	Panel No.	1350 to 1359
-----------------------------	-------------------	------------------	--------------

■ **Function**

- This panel pops up and is displayed by touching the [Edit] switch on a recipe smart object.
- This panel is for selecting the recipe to be set on a recipe setting smart object.
- Recipes can be duplicated by touching the [Copy] key.
- Recipes can be deleted by touching the [Delete] key.
- Touching the [Close] key closes the panel, and returns to the state before the menu panel was called.

■ **Example**

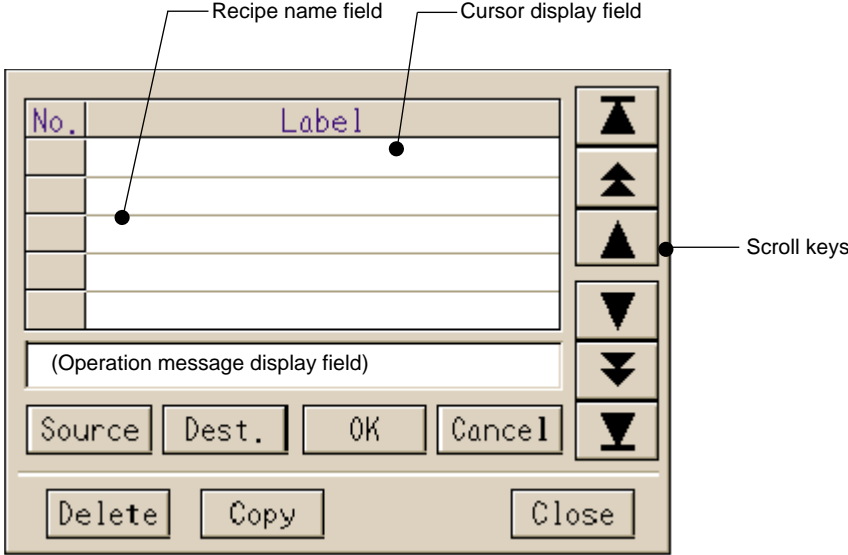

- **Copy**
This item duplicates the selected recipe data to the specified recipe. Select the recipe to be duplicated using the cursor, and enter the duplicate source and destination by the [Source] and [Dest.] keys. The confirmation message is displayed. Determine the duplicate by either the [OK] or [Cancel] key.
- **Delete**
This item deletes the data of the recipe No. at the cursor display field. The confirmation message is displayed. Determine the delete by either the [OK] or [Cancel] key.
- **Close**
This item cancels the selection and returns to the call panel.
- **Recipe name field**
This item displays the name of the currently set recipe using up to 36 1-byte characters.

Appendix LIST OF SMART OBJECT GRAPHICS

This appendix lists the graphics that are included in the smart object library. Each smart object graphic has a unique number. Refer to that number when pasting the smart object. Transparent graphics are indicated as follows:

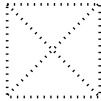

■ Switch and Lamp Graphics

With smart objects for which the ON graphic is automatically selected when the OFF graphic is selected, the graphic No. of ON graphics is the No. obtained by adding 500 to the OFF graphic No. Note, however, that when the graphic No. of an OFF graphic exceeds 500, the graphic No. of ON graphics is the No. obtained by subtracting 500 from the OFF graphic No.

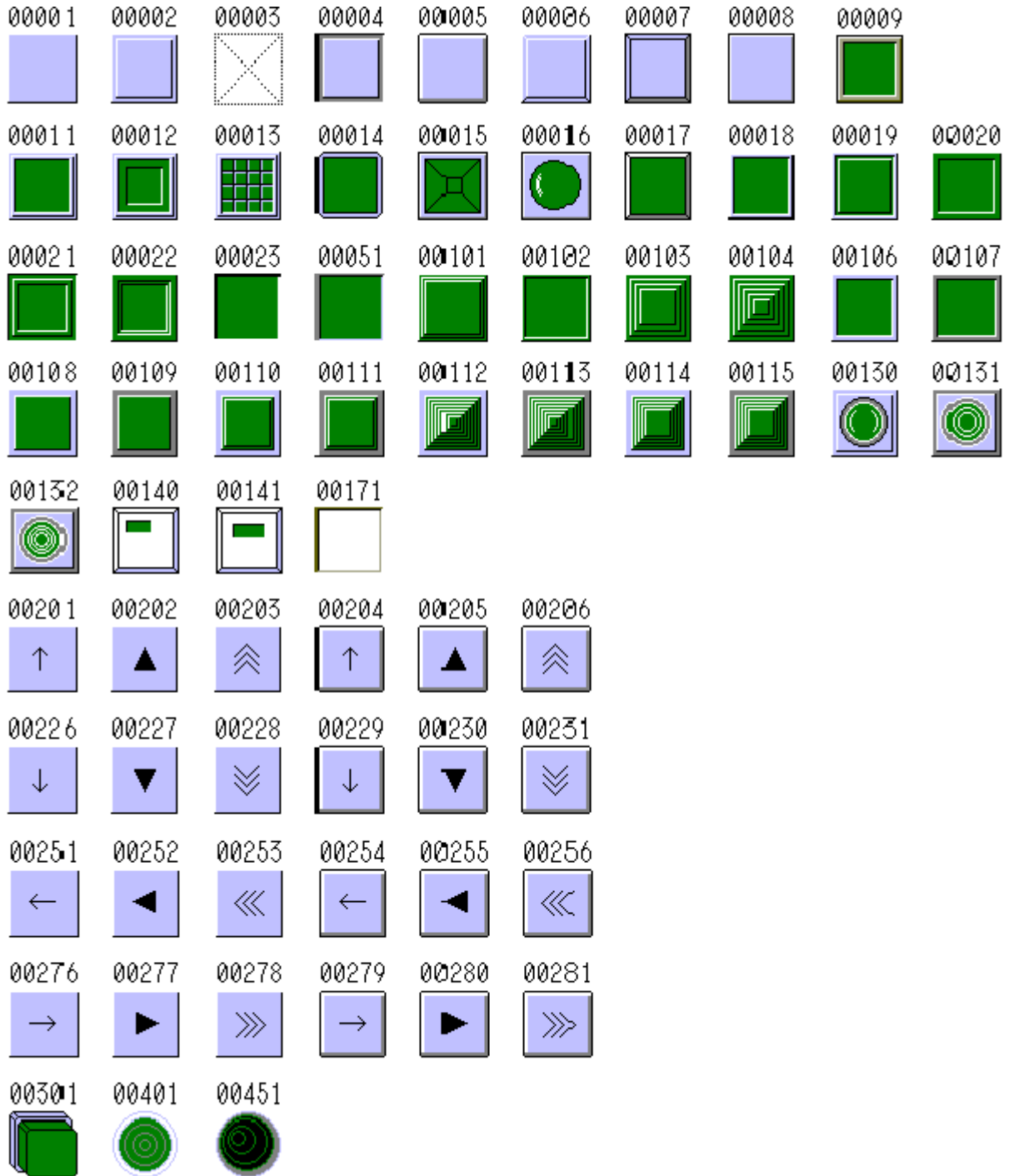

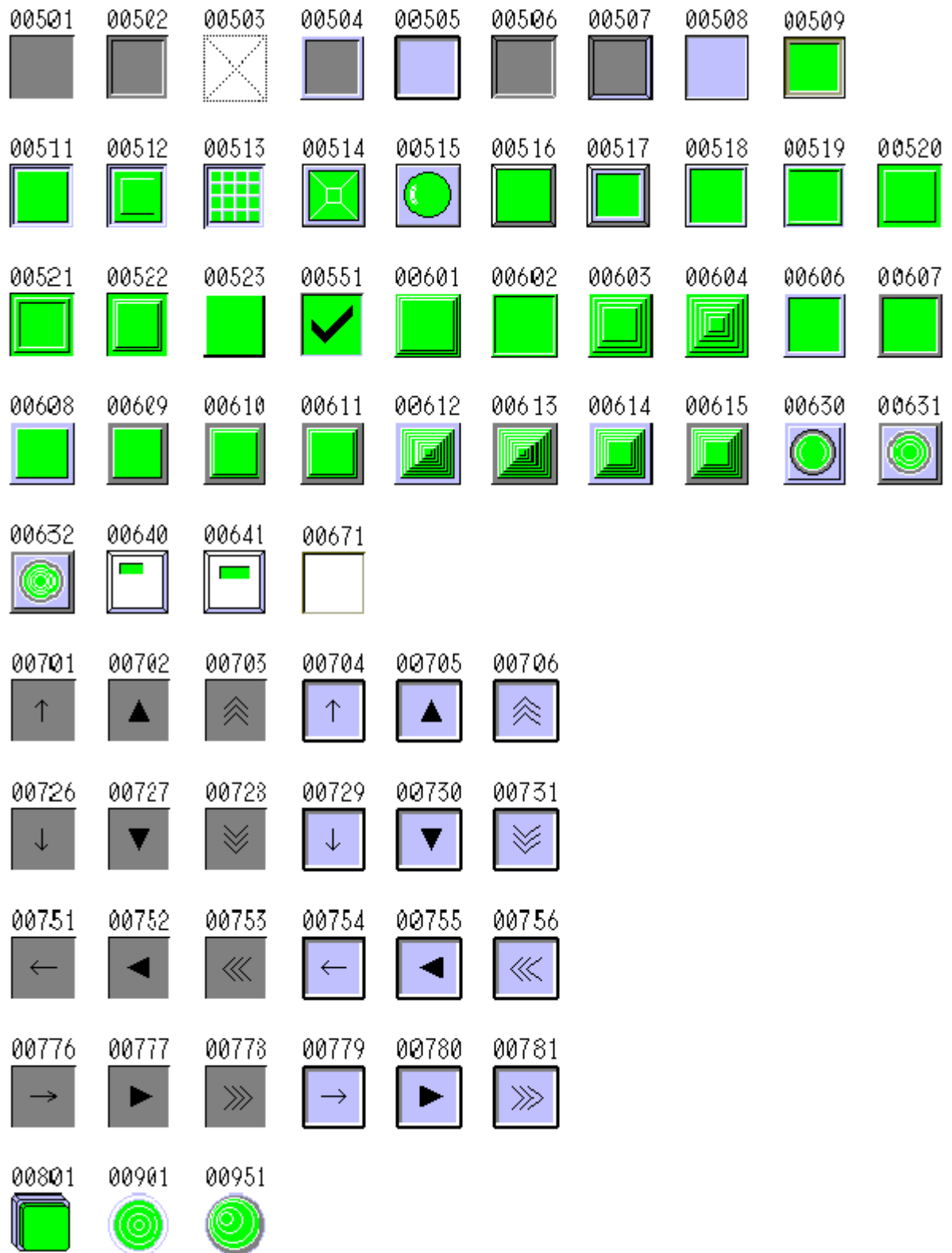

■ Rocker Switch Graphics

With smart objects for which the ON graphic is automatically selected when the OFF graphic is selected, the graphic No. of ON graphics is the No. obtained by adding 500 to the OFF graphic No.

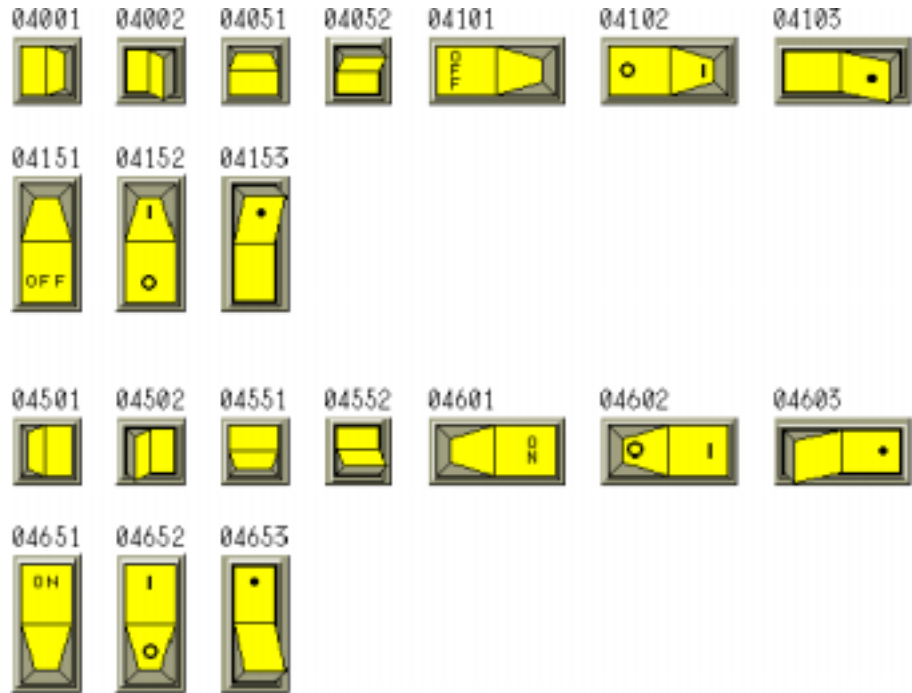

■ Slide Switch Graphics

With smart objects for which the ON graphic is automatically selected when the OFF graphic is selected, the graphic No. of ON graphics is the No. obtained by adding 500 to the OFF graphic No.

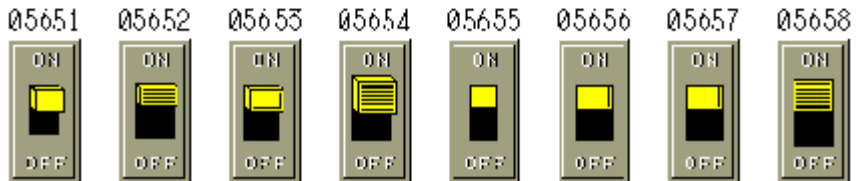
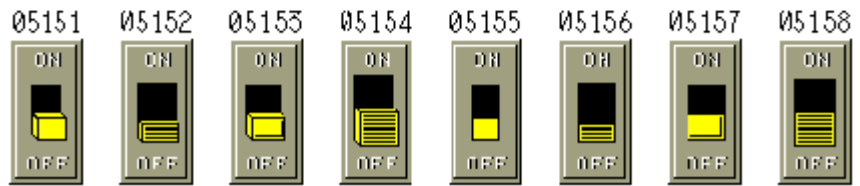

■ Inching Switch Graphics

● Left/right



● Up/down

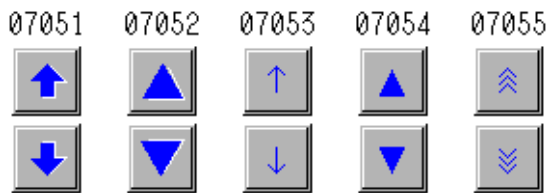

● 4-way

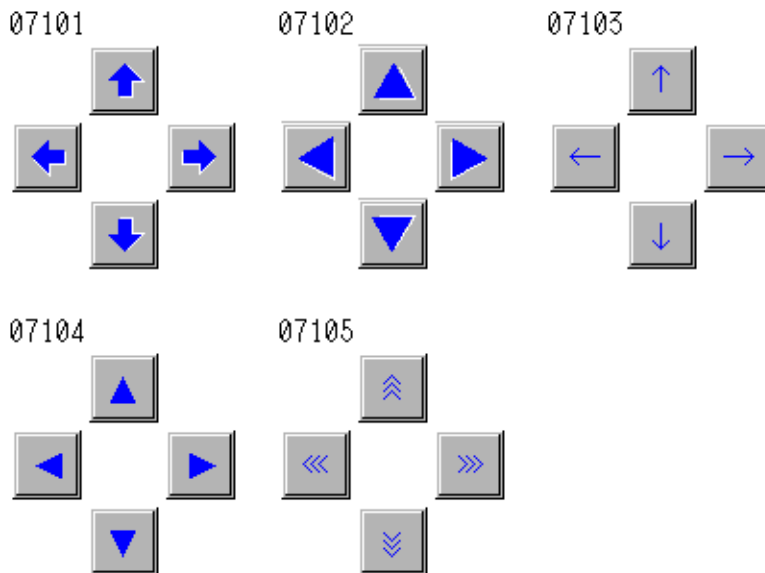

● 8-way

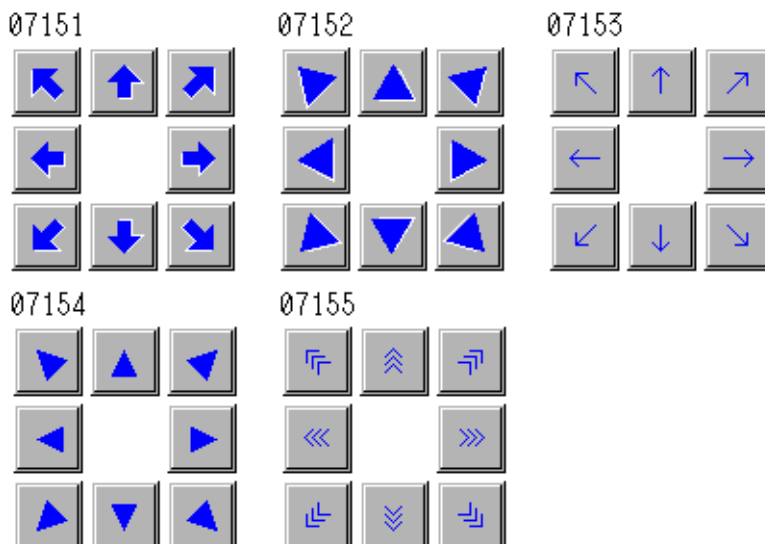

■ Border Graphics

● For 1 single-byte character

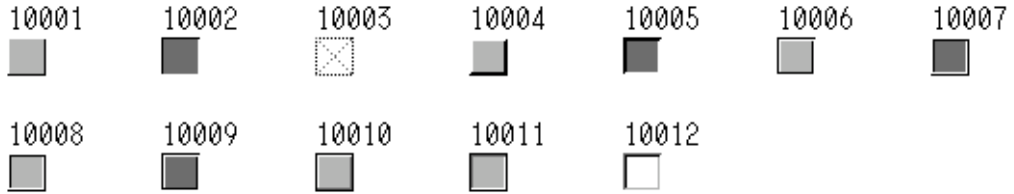

● For 2 single-byte characters

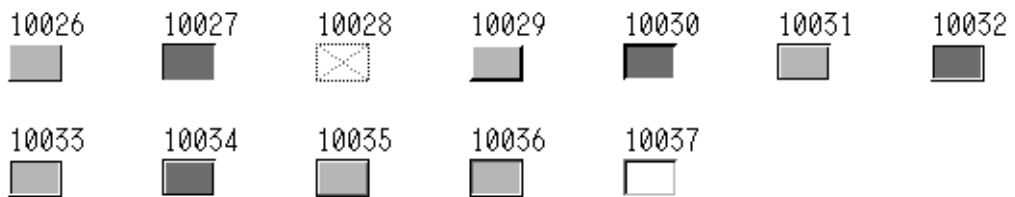

● For 3 single-byte characters

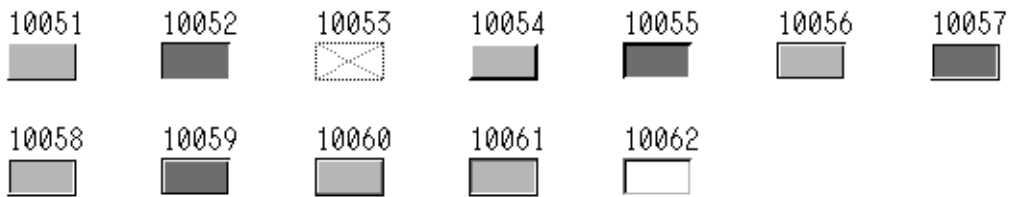

● For 4 single-byte characters

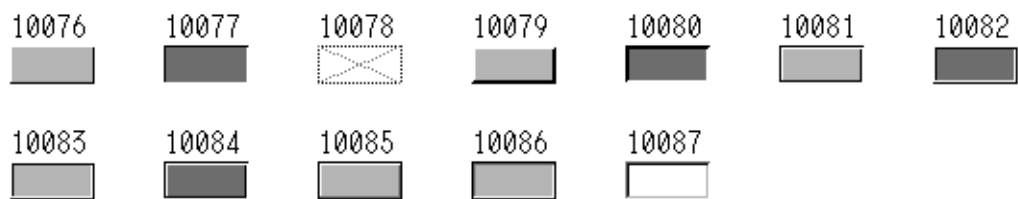

● For 5 single-byte characters

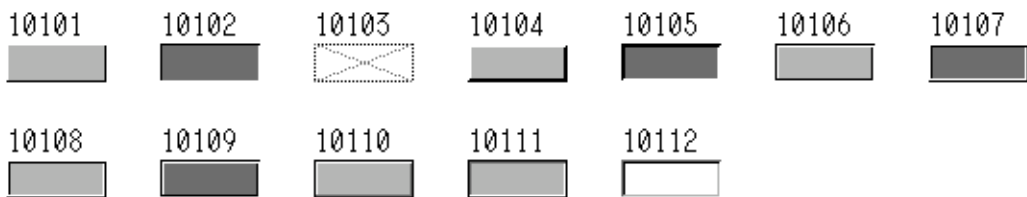

● For 6 single-byte characters

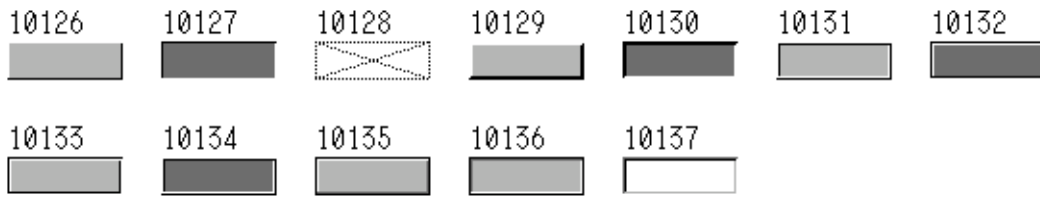

● For 7 single-byte characters

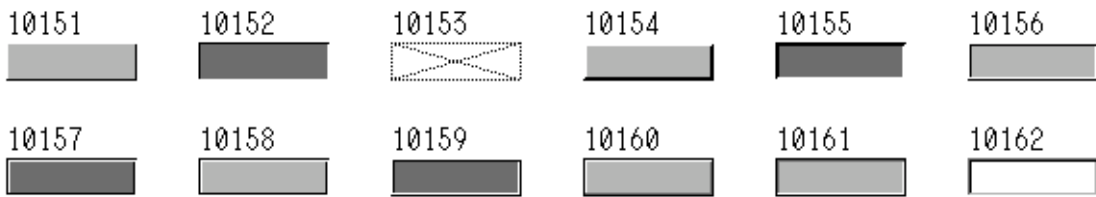

● For 8 single-byte characters

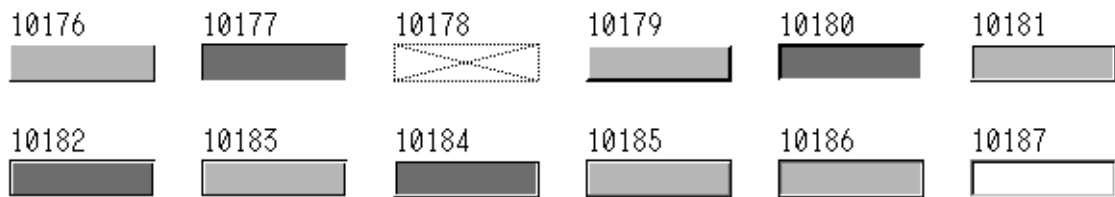

● For 9 single-byte characters



● For 10 single-byte characters

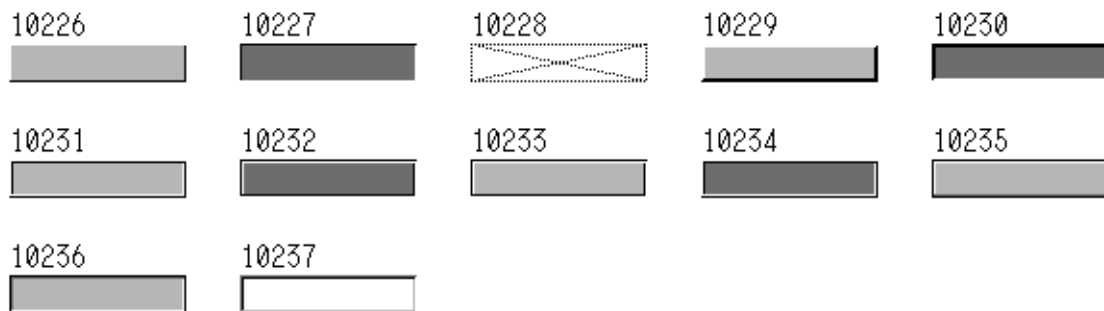

● For 11 single-byte characters

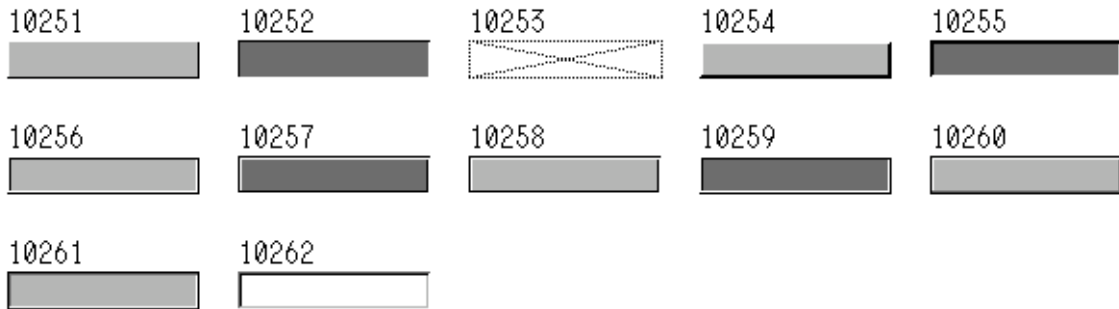

● For 12 single-byte characters

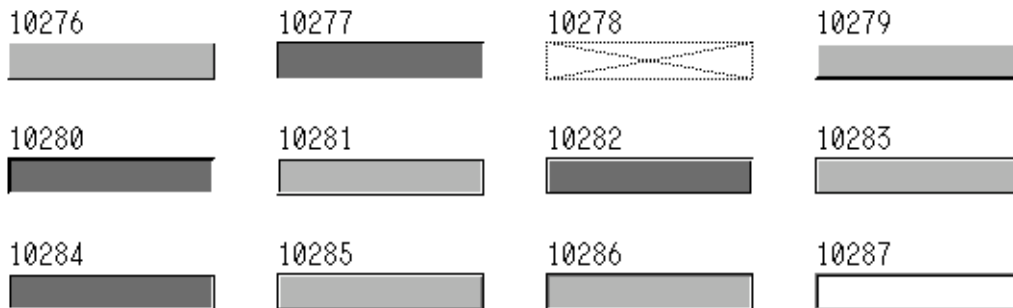

● For 13 single-byte characters

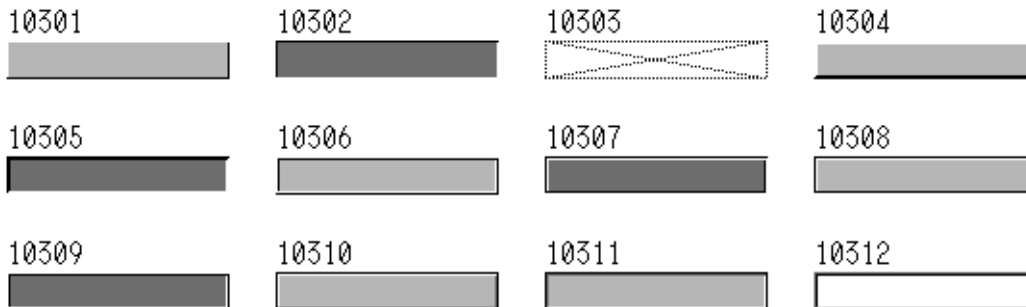

● For 14 single-byte characters

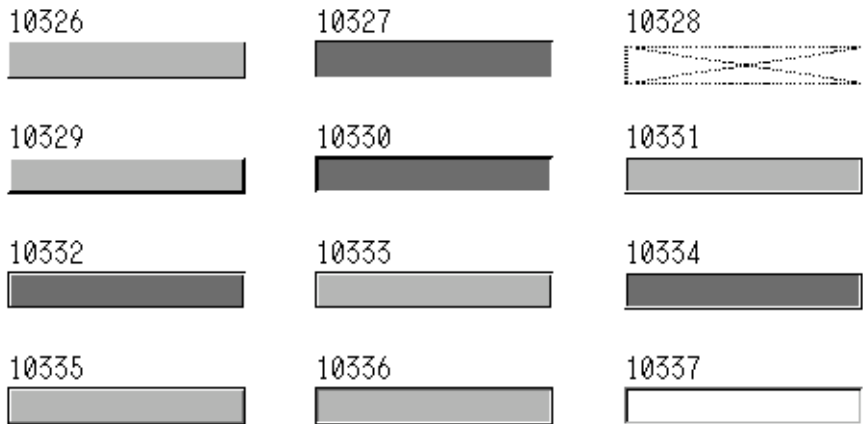

● For 15 single-byte characters



● For 16 single-byte characters

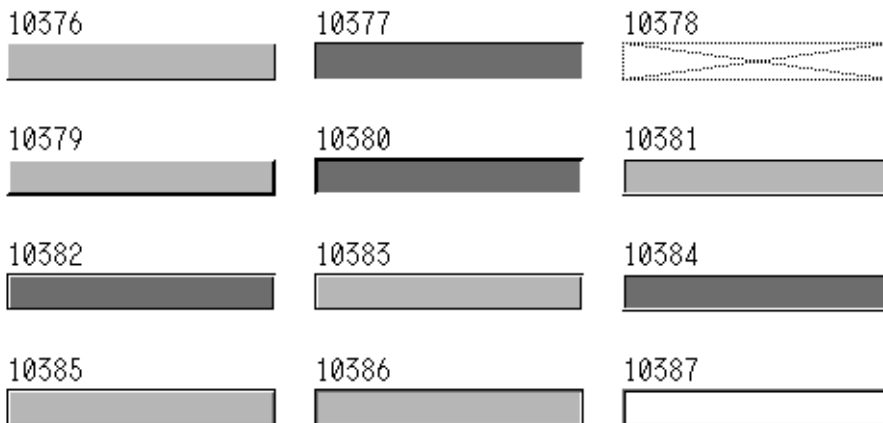

■ Piping Graphics

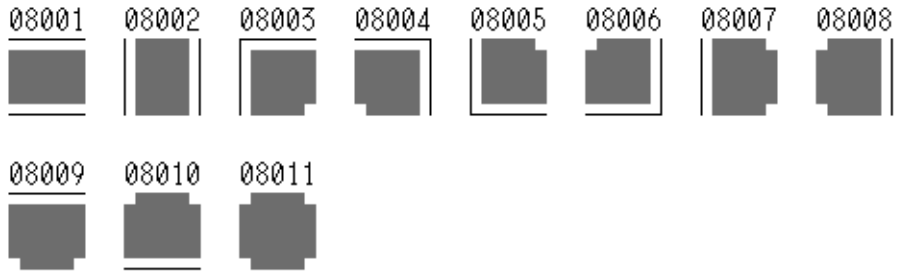

■ Tank Graphics

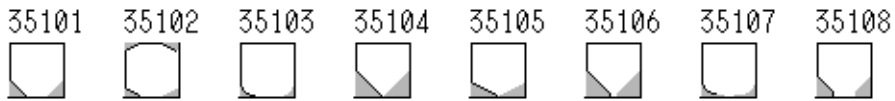

■ Meter Graphics

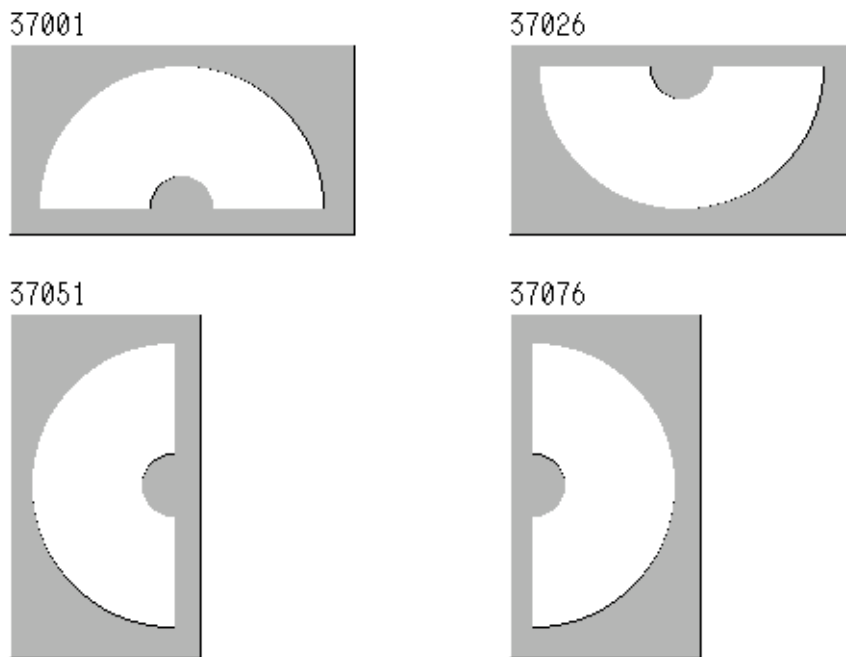

■ Analog Clock Graphics

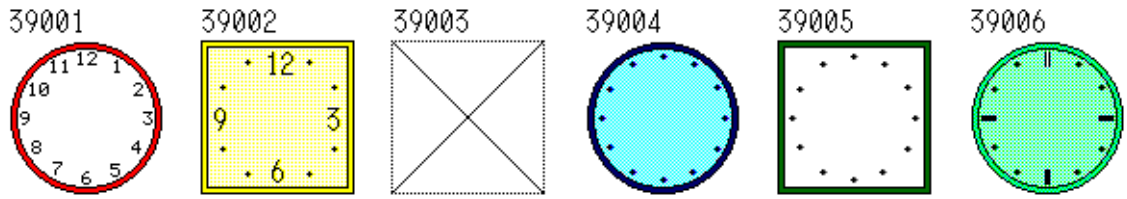

■ Numeric Keypad Graphic for Password Entry

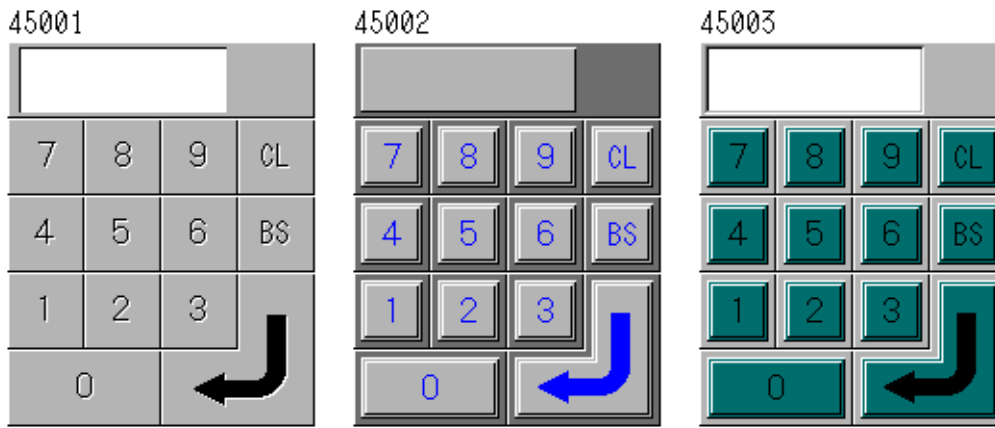

■ UP/DOWN Setter Graphics



■ Alarm History Graphics

61002

No.	ALARM	OCCUR	RECOVER
		- :	- :
		- :	- :
		- :	- :
		- :	- :
		- :	- :

Navigation icons: Home, Up, Left, Down, Right, End

61003

No.	ALARM	OCCUR	RECOVER
		- :	- :
		- :	- :
		- :	- :
		- :	- :
		- :	- :

Navigation icons: Home, Up, Left, Down, Right, End

■ Alarm Summary Graphics

62002

No.	ALARM	ALARM NAME
-MESSAGE-		

62003

No.	ALARM	ALARM NAME
-MESSAGE-		

■ Alarm Count Display Graphics

63002

ALARM	ALARM NAME	NUMBER



A set of six navigation buttons arranged in a row. From left to right: a double-up arrow, a single-up arrow, a single-down arrow, a single-down arrow, a double-down arrow, and a triple-down arrow.

63003



A set of six navigation buttons arranged in a row, identical to the set in the previous graphic. From left to right: a double-up arrow, a single-up arrow, a single-down arrow, a single-down arrow, a double-down arrow, and a triple-down arrow.

■ SDC10 Graphics

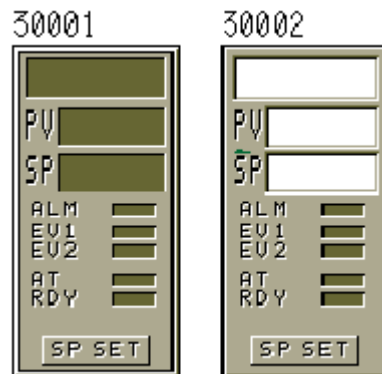

■ SDC20/21 Graphics

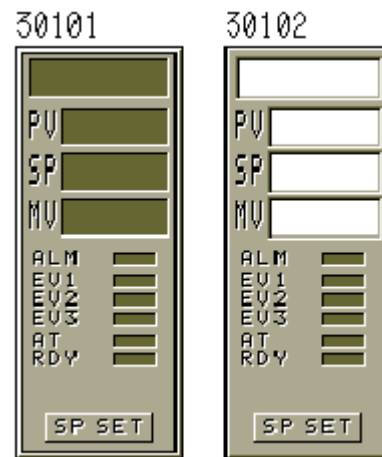

■ SDC30/31 Graphics

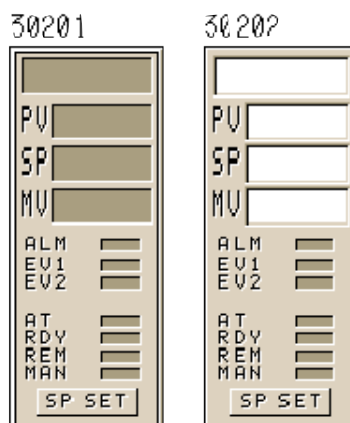

■ SDC40A Graphics

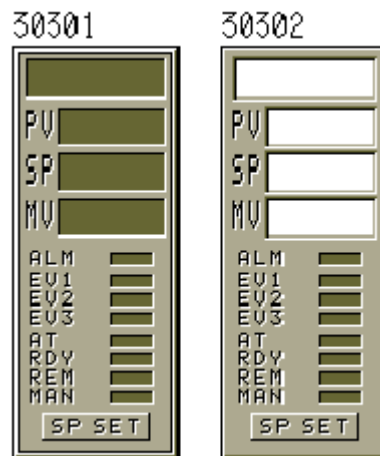

■ DMC10 (2 channel model)

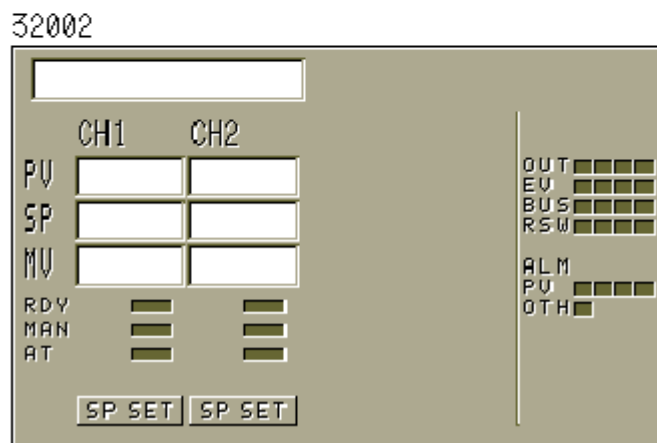
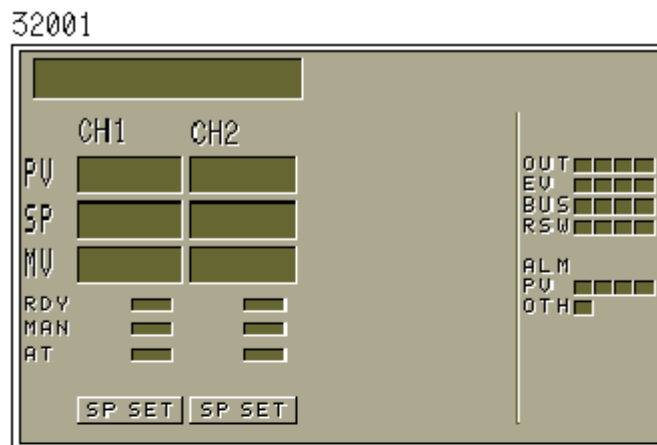

■ DMC10 (4 channel model)

32101

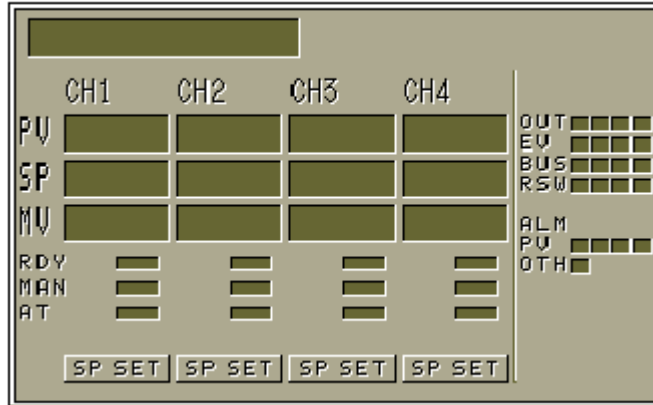

32102

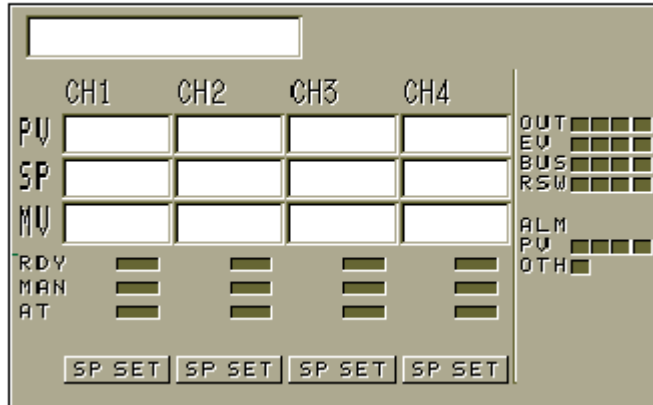

■ CB508 Graphics

31001

[Title Bar]					
	CH1	CH2	CH3	CH4	ALARM
PV	[]	[]	[]	[]	PV []
SP	[]	[]	[]	[]	SP []
MV	[]	[]	[]	[]	DT []
ALM	PV [] SP []	PV [] SP []	PV [] SP []	PV [] SP []	CT []
AT	[]	[]	[]	[]	EVENT
RDY	[]	[]	[]	[]	
	CH5	CH6	CH7	CH8	2 []
PV	[]	[]	[]	[]	3 []
SP	[]	[]	[]	[]	4 []
MV	[]	[]	[]	[]	5 []
ALM	PV [] SP []	PV [] SP []	PV [] SP []	PV [] SP []	6 []
AT	[]	[]	[]	[]	7 []
RDY	[]	[]	[]	[]	8 []

31002

[Title Bar]					
	CH1	CH2	CH3	CH4	ALARM
PV	[]	[]	[]	[]	PV []
SP	[]	[]	[]	[]	SP []
MV	[]	[]	[]	[]	DT []
ALM	PV [] SP []	PV [] SP []	PV [] SP []	PV [] SP []	CT []
AT	[]	[]	[]	[]	EVENT
RDY	[]	[]	[]	[]	
	CH5	CH6	CH7	CH8	2 []
PV	[]	[]	[]	[]	3 []
SP	[]	[]	[]	[]	4 []
MV	[]	[]	[]	[]	5 []
ALM	PV [] SP []	PV [] SP []	PV [] SP []	PV [] SP []	6 []
AT	[]	[]	[]	[]	7 []
RDY	[]	[]	[]	[]	8 []

■ Trend Graphics

- 1-axis trend: Without events

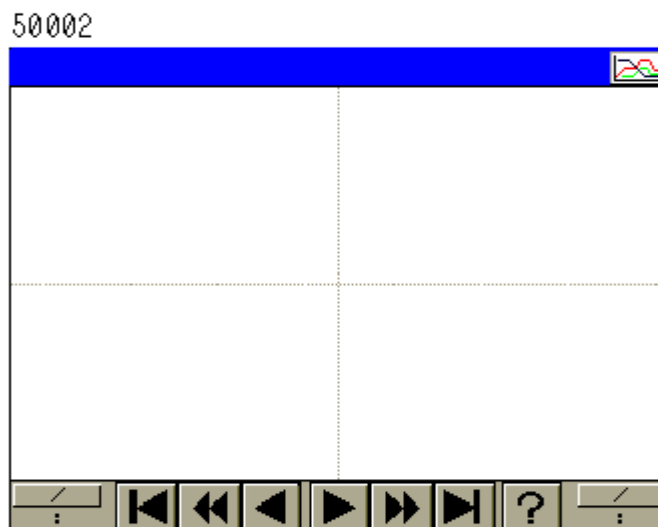

50011

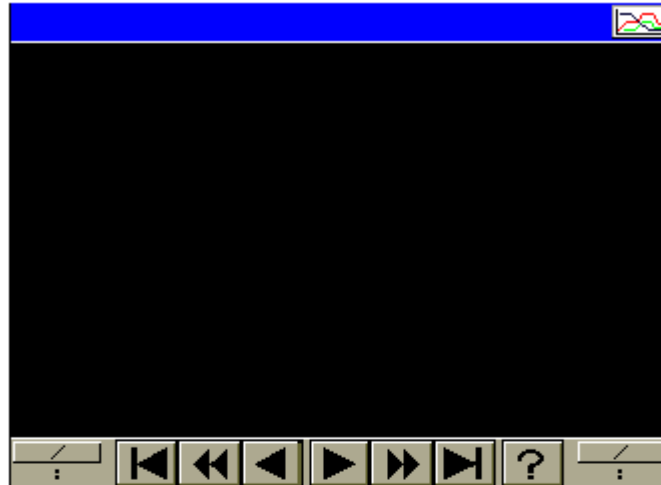

50012

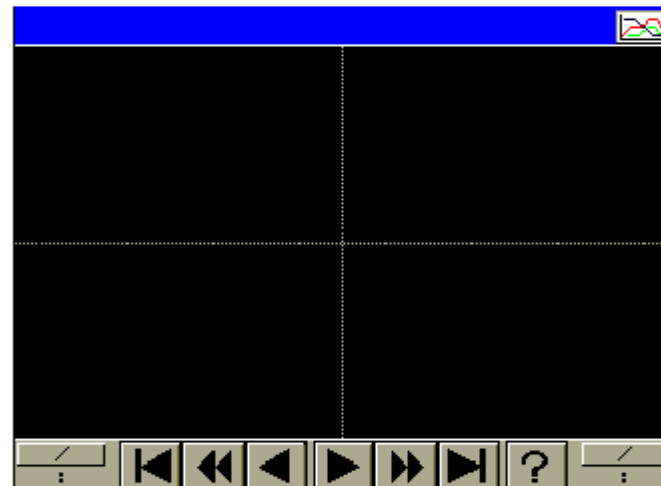

50013

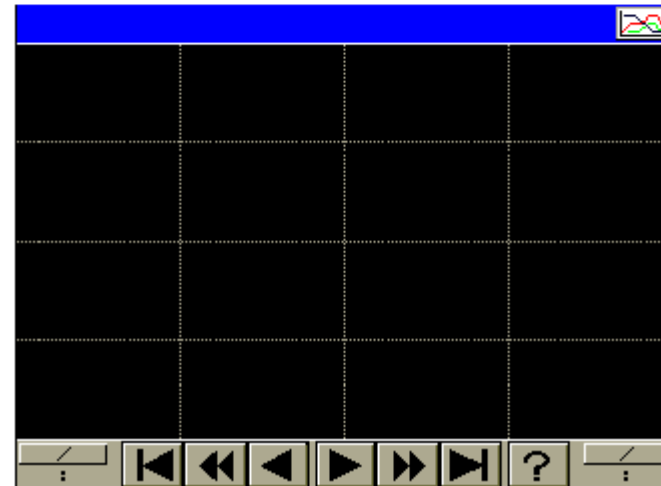

● Trend: Event 1

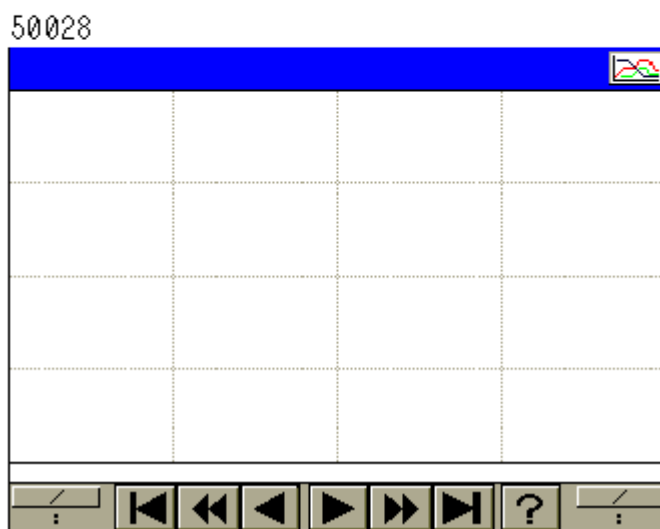
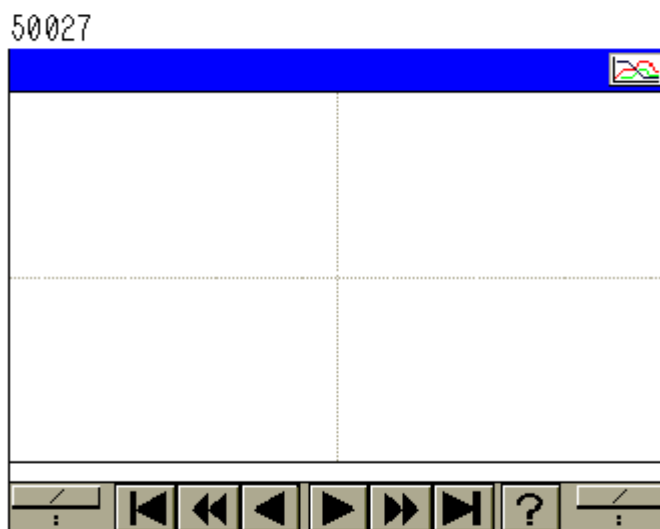

50036

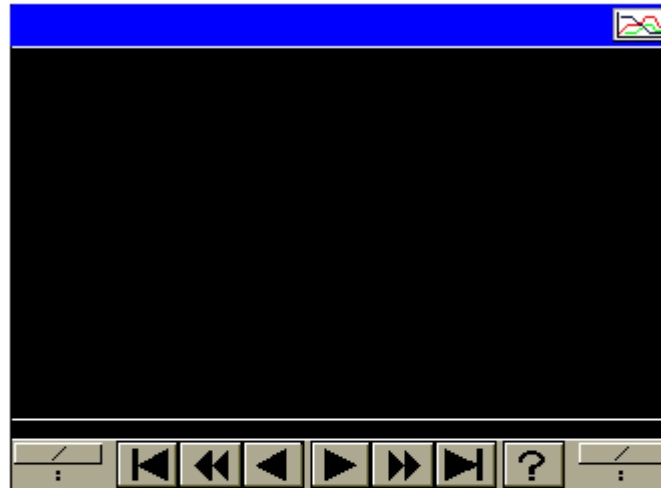

50037

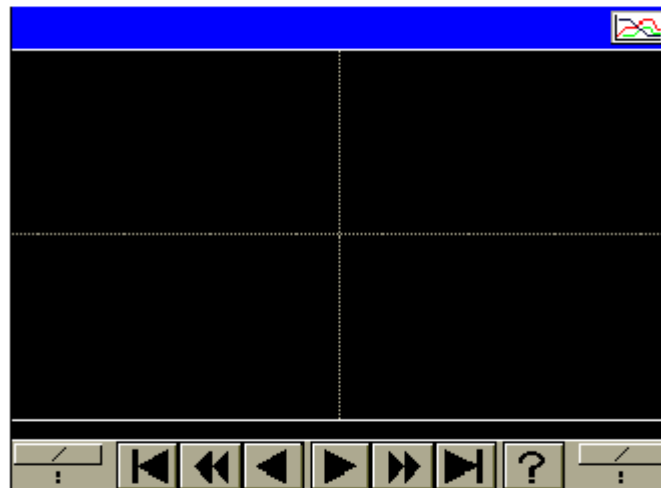

50038

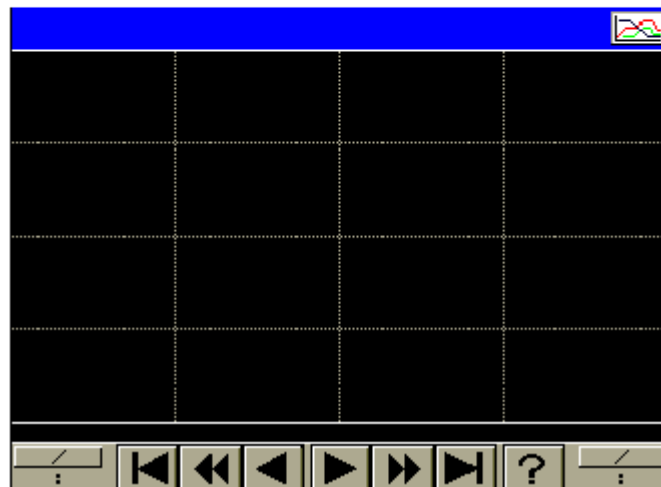

● Trend: Event 2

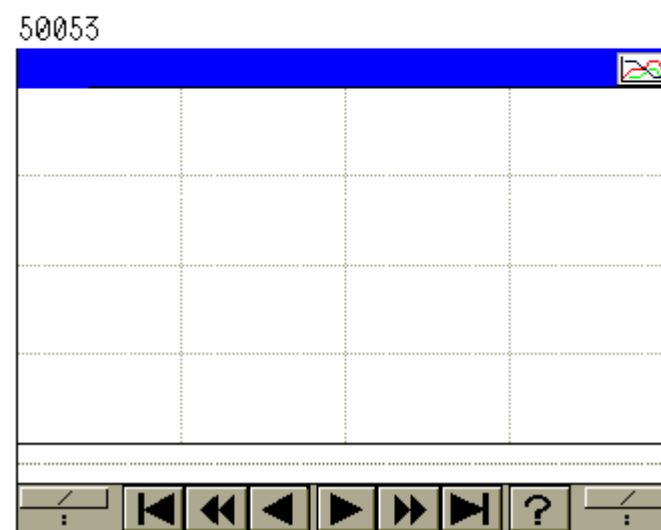
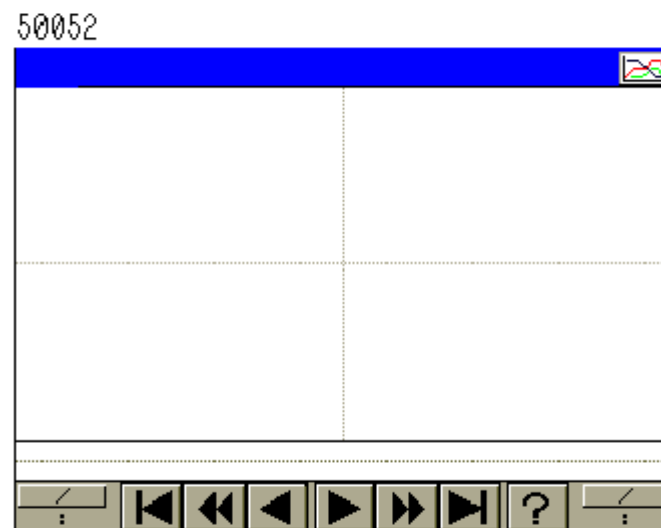
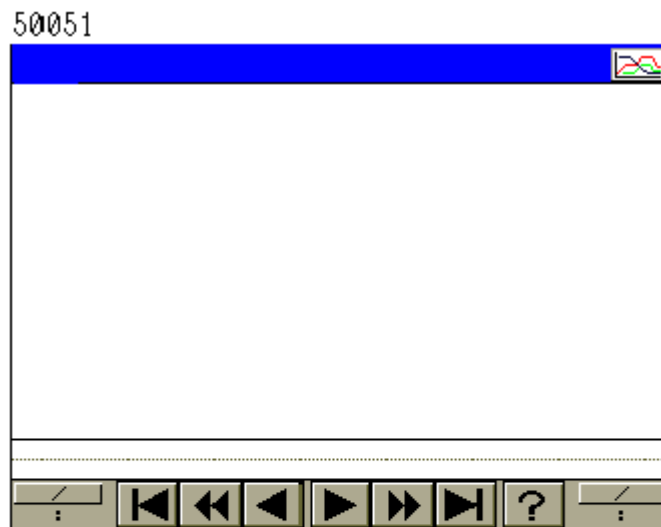

50061

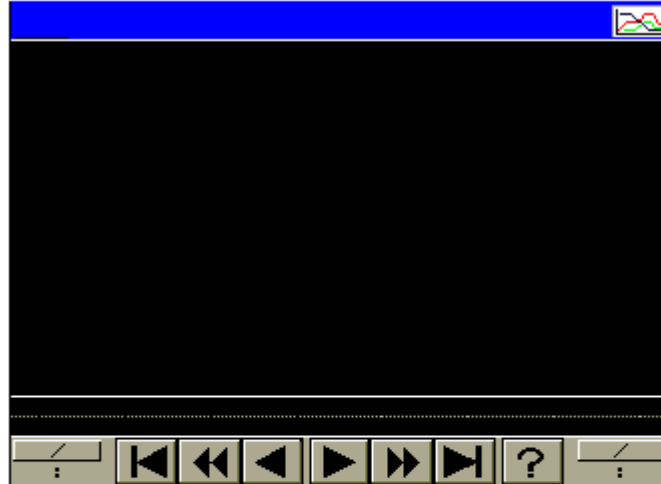

50062

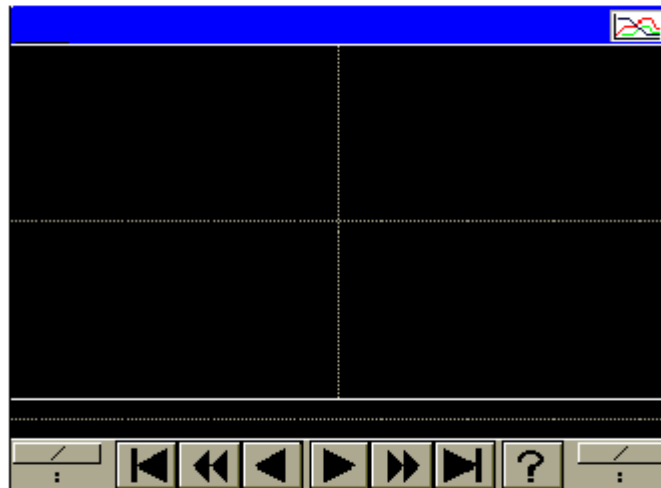

50063

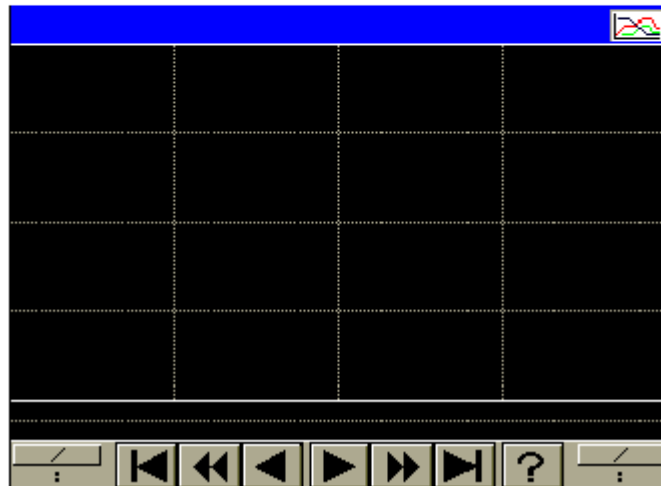

● Trend: Event 3

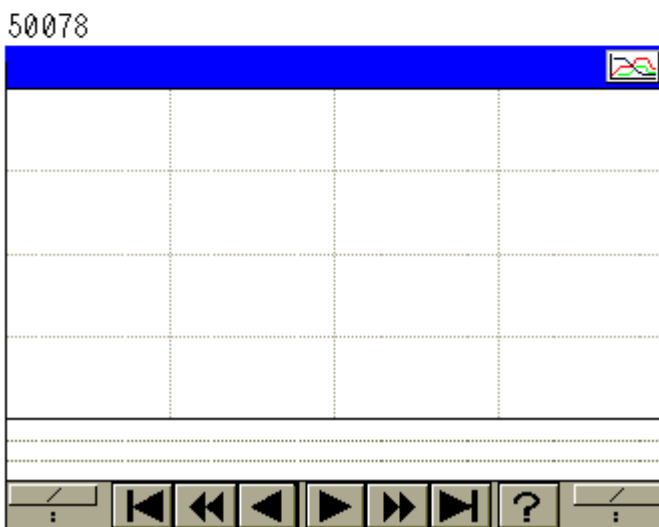
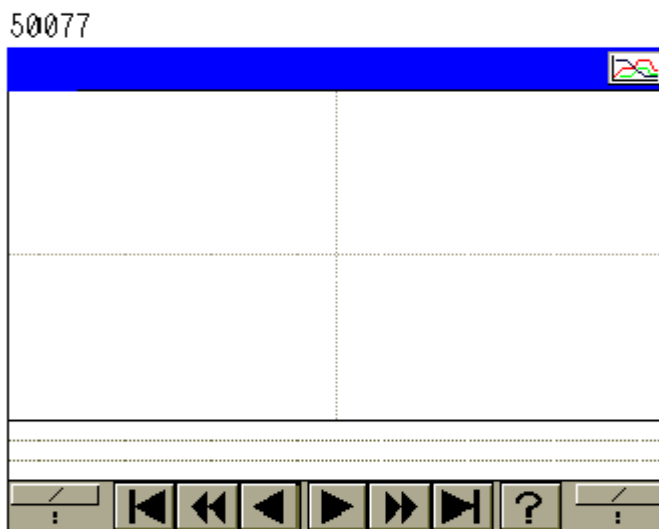
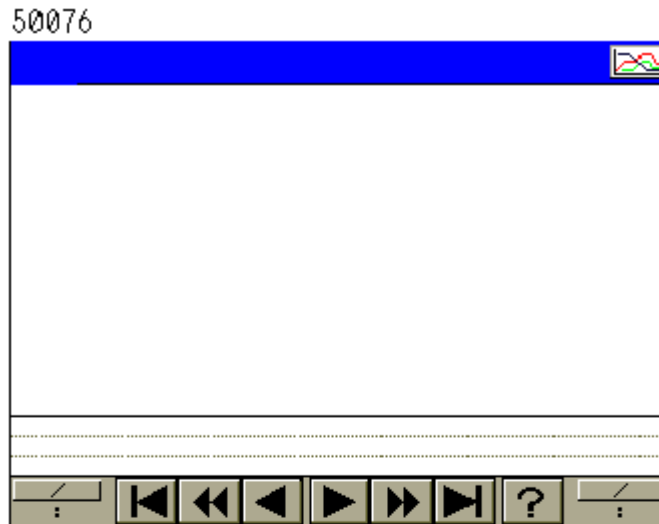

50086

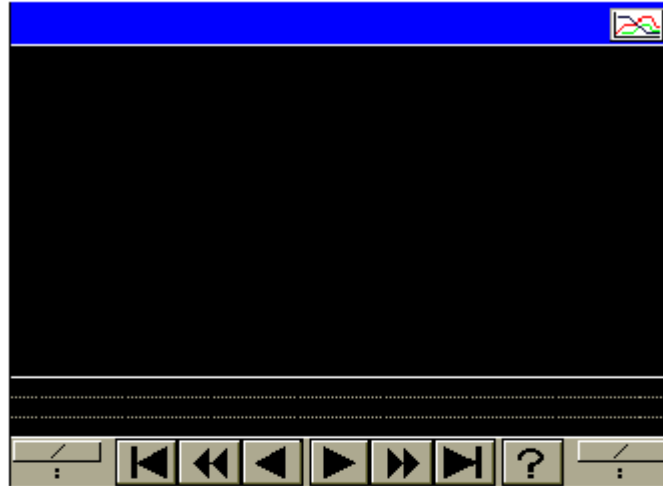

50087

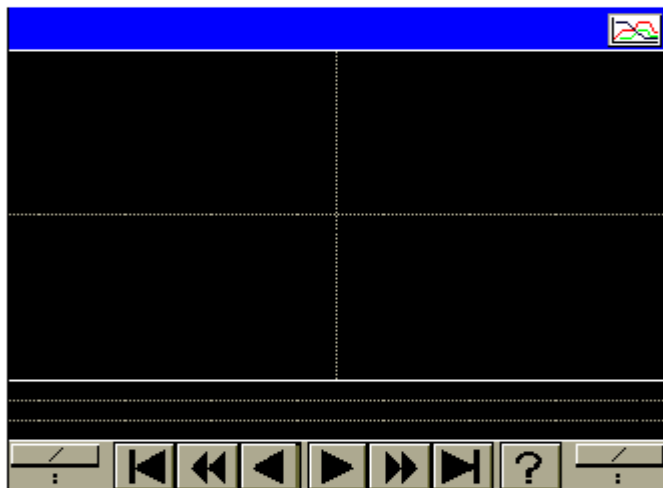

50088

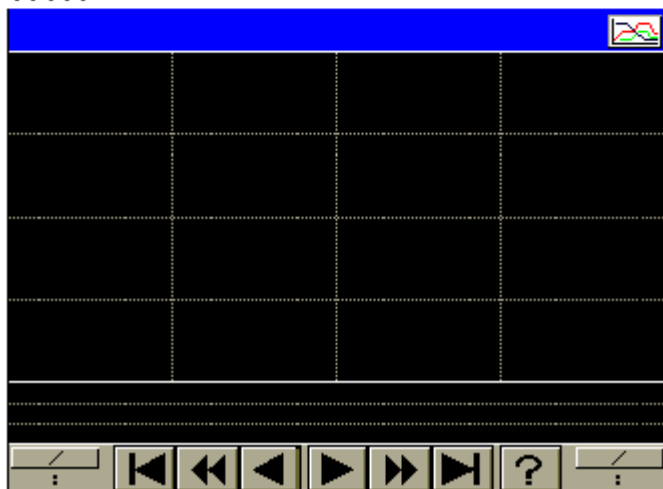

● Auto write

51501

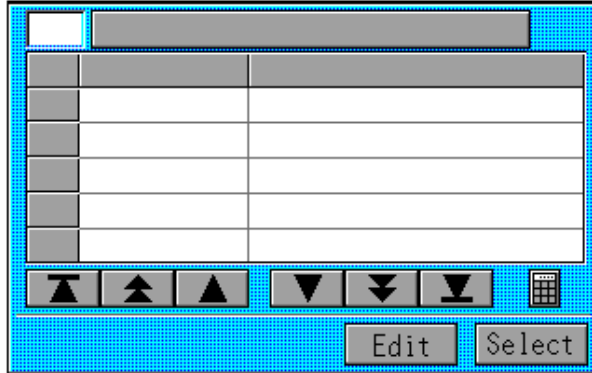

51511

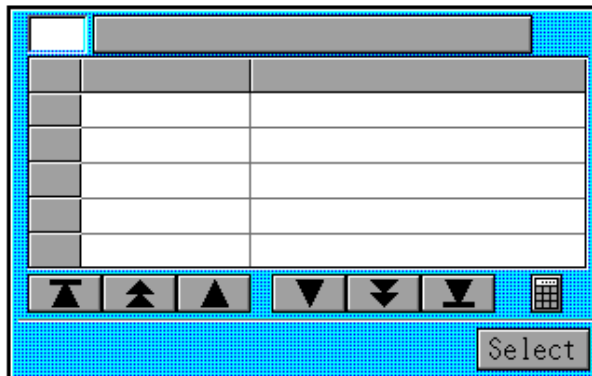

51521

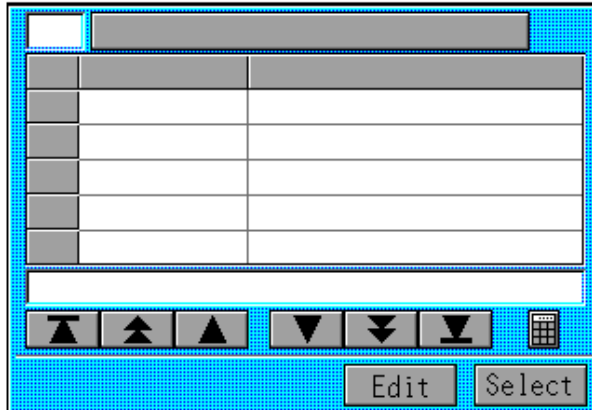

51531

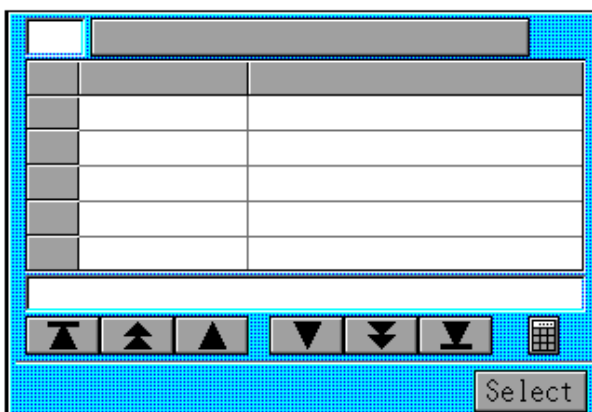

Specifications are subject to change without notice.

YAMATAKE

Yamatake Corporation

Control Product Division

Sales contact: Yamatake Corporation,
IBD Sensing and Control Department

Totate International Building

2-12-19 Shibuya Shibuya-ku Tokyo 150-8316 Japan

Phone: 81-3-3486-2380

Fax: 81-3-3486-2300

This has been printed on recycled paper.

Printed in Japan.

1st Edition: Issued in Feb., 2001(W)

2nd Edition: Issued in Mar., 2001(W)