

WaterMAG Smart Electromagnetic Flowmeter Detector (for water measurement applications)

Model MGW18F

OVERVIEW

The WaterMAG electromagnetic flowmeter detector is a high performance, highly reliable flowmeter developed with Yamatake's proven MagneW flow measurement technologies. Model MGW18 offers superior process flowrate measurement when coupled with wide range of MGG14C converters.

APPLICATIONS

- Industrial water
- Wastewater
- Cooling water/Circulating water

PRINCIPLE OF OPERATION

WaterMAG electromagnetic flowmeter is based on Faraday's Law which states that the voltage induced in a conductor moving through a magnetic field is proportional to the velocity of that conductor.

STANDARD FEATURES (WITH MGG14C CONVERTER)

- Standard $\pm 0.5\%$ of rate accuracy
- Sizes available from 8 to 40 inches
- Forward, reverse and totalization
- Empty pipe detection
- 3 outputs: 4 to 20mA DC, totalizer pulse and contact outputs
- Non-volatile EEPROM memory
- 3-line, backlit display
- SFC, HART communications
- User-selectable damping & low flow cutoff status contacts
- Rotable modular display
- Chloroprene rubber liner



FUNCTIONAL SPECIFICATIONS

Type of protection

Model MGW18
IEC IP67 equivalent (except terminal box)

Measurement flow range

Refer to the minimum/maximum set ranges shown in the table below.

Line size

200, 250, 300, 350, 400, 450, 500, 600, 700, 800, 900, 1000mm
(8, 10, 12, 14, 16, 18, 20, 24, 28, 32, 36, 40inches)

Flange rating

ANSI 150, DIN PN10

Size		Minimum flow velocity range is 0 to 0.1 m/s (0 to 0.33 ft/s)		Maximum flow velocity range is 0 to 10 m/s (0 to 32.8 ft/s)		Conversion factor K
		Minimum range		Maximum range		
mm	inch	m ³ /h	GPM	m ³ /h	GPM	
200	8	0 to 11.31	0 to 49.81	0 to 1130	0 to 4980	0.008842
250	10	0 to 17.68	0 to 77.82	0 to 1767	0 to 7781	0.005659
300	12	0 to 25.45	0 to 112.1	0 to 2544	0 to 11205	0.003930
350	14	0 to 34.64	0 to 152.6	0 to 3463	0 to 15251	0.002887
400	16	0 to 45.24	0 to 199.3	0 to 4523	0 to 19920	0.002210
450	18	0 to 57.26	0 to 252.2	0 to 5725	0 to 25211	0.001747
500	20	0 to 70.69	0 to 311.3	0 to 7068	0 to 31125	0.001415
600	24	0 to 101.8	0 to 448.3	0 to 10178	0 to 44820	0.0009824
700	28	0 to 138.6	0 to 610.1	0 to 13854	0 to 61005	0.0007218
800	32	0 to 181.0	0 to 796.9	0 to 18095	0 to 79680	0.0005526
900	36	0 to 229.1	0 to 1009	0 to 22902	0 to 100846	0.0004366
1000	40	0 to 282.8	0 to 1246	0 to 28274	0 to 124501	0.0003537

Flow conversion Velocity V(m/s) = K × Q

$$K = \text{Flow conversion factor} = \frac{1}{3600} \times \frac{4}{\pi D^2}$$

Q = Flow rate (m³/h)

Temperature range and pressure range of process fluid

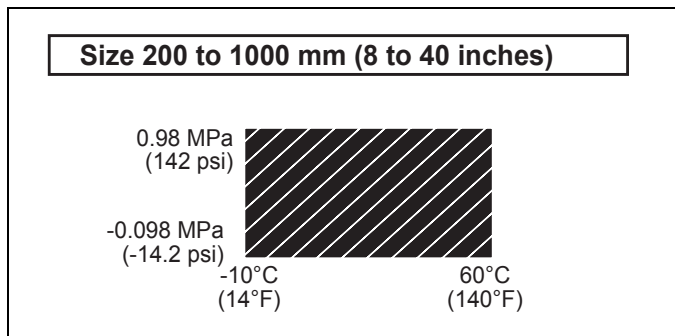

Ambient temperature limits

-30 to +60°C (-22 to +140°F) (remote model/chloro-prene rubber lining)

Ambient humidity limits

5 to 90% RH

Measurable electrical conductivity

Combined with model MGG14C converter
50 μS/cm or more

Optional specifications

Test report

Calibration certificate, withstand voltage test, insulation resistances, hydrostatic pressure test, physical inspection are included.

Tag number to the terminal box name plate

Stamp tag with the specified number and attach to the terminal box. The maximum number of characters of the tag number is 8.

Tag number plate wired to the flowmeter

Detector can be fitted with a stainless steel tag wired to neck. Maximum 16 characters.

PERFORMANCE SPECIFICATIONS

Accuracy

(in combination with the model MGG14C converter)

Velocity

±0.8 to 8m/s (2.62 to 26.2ft/s)

Accuracy;

±0.5% of rate ±3.5mm/s

(±0.5% of rate ±0.115ft/s)

Velocity

±0 to 0.8m/s (0 to 2.62ft/s)

Accuracy;

±6.3mm/s(±0.02ft/s)

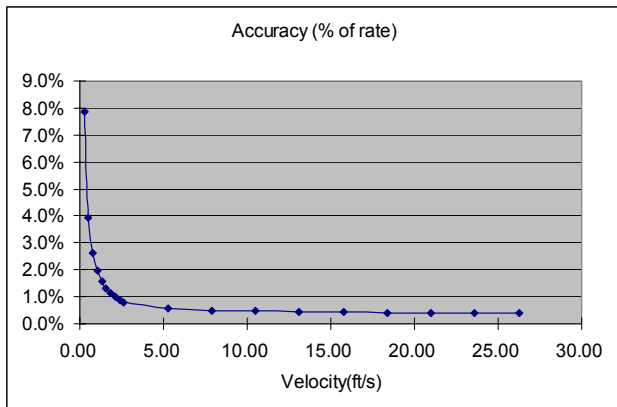

PHYSICAL SPECIFICATIONS

Main body material

Measuring pipe materials (non wetted)

SUS304 stainless steel

Flange (non wetted)

Carbon steel

Case

Carbon steel

Terminal box

Aluminum alloy

Finish

Standard

Urethane paint

Color

Light beige

Process wetted material

Lining

Chloroprene rubber

Electrode

SUS316

Grounding ring

SUS304

Electrical connection

1/2NPT internal thread

Pipe connection

Flange

Grounding

Resistance less than 100 Ω

Length of straight pipe

Upstream side

A minimum five straight pipe diameters

A minimum 10 straight pipe diameters is required if a diffuser/valve/pump is installed upstream side.

Downstream side

Two straight pipe diameters is recommended.

Cable (between remote detector and converter)

Maximum length 200 m (656 ft.)

(depends on fluid conductivity)

Outer diameter 10 to 12 mm (0.4 to 0.47 inch)

Signal cable

Recommended cable: MGA12W

(O.D. 11.4mm (0.44inch), 0.75 mm²(0.0012in²) or equivalent (CVVS, CEEV etc.)

Excitation cable

Recommended cable: MGA12W

(O.D. 10.5 mm(0.41inch), 2 mm²(0.0003in²) or equivalent (CVV and others)

MODEL SELECTION MODEL SELECTION

Flange type (200 to 1000 mm (8 to 40 inches)) Chloroprene rubber lining
 Model MGW18F - I II III IV V VI VII VIII IX X - XI - XII / Options (options can be selected from Table A below)

Basic model no.		Selections										Optional selections		
MGW18F														
I	Line size	200 mm (8 inches)	200											
		250 mm (10 inches)	250											
		300 mm (12 inches)	300											
		350 mm (14 inches)	350											
		400 mm (16 inches)	400											
		450 mm (18 inches)	450											
		500 mm (20 inches)	500											
		600 mm (24 inches)	600											
		700 mm (28 inches)	700											
		800 mm (32 inches)	800											
		900 mm (36 inches)	900											
1000 mm (40 inches)	10H													
II	Lining	Chloroprene rubber		R										
III	Piping connection	Flange ANSI 150		A1										
		Flange DIN PN10		D1										
IV	Flange material	Standard			1									
V	Electrode	SUS316				S								
VI	Grounding ring	None						D						
		SUS304						E						
VII	Electrical connection / watertight gland	1/2NPT internal thread							5					
VIII	Face-to-face dimensions	Standard								A				
IX	Installation	Standard									A			
X	Calibration	Standard										A		
XI	Finish/Paint	Standard Paint											X	

Table A

XII Options	None	X
	Test report	A
	Tag number plate wired to the flowmeter (Note 1)	L
	Tag number engraved on the Tag plate of the terminal box (Note 1)	K

Note) 1. Must be selected for Tag no. requirement

DIMENSIONS

Flange type with ANSI150 Flange

[Unit: mm (inch)]

Size 200(8inches) to 600 mm (24 inches)

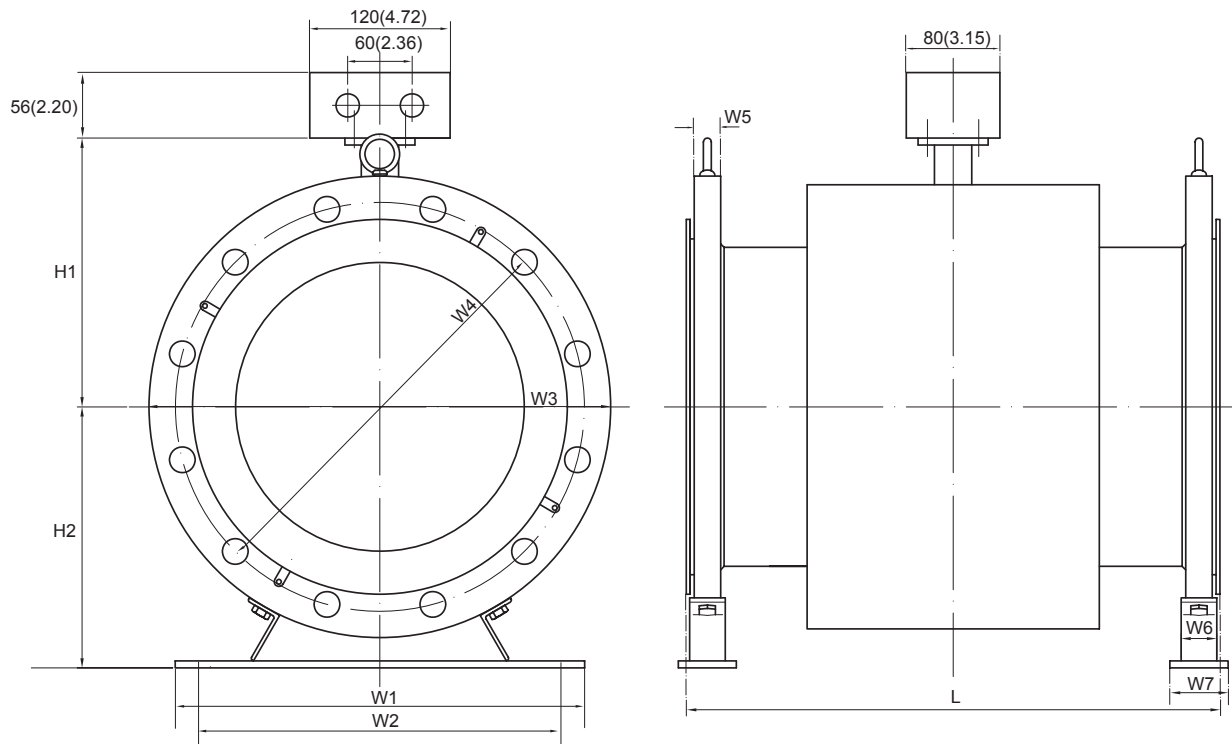

Size	mm		200	250	300	350	400	450	500	600
	(inches)		(8)	(10)	(12)	(14)	(16)	(18)	(20)	(24)
Face to face dimension	L	mm	350	450	500	550	600	600	600	650
		(inches)	(13.78)	(17.72)	(19.69)	(21.65)	(23.62)	(23.62)	(23.62)	(25.59)
Height	H1	mm	205	230	255	280	308	333	359	409
		(inches)	(8.07)	(9.06)	(10.04)	(11.02)	(12.13)	(13.11)	(14.13)	(16.10)
	H2	mm	207	228	273	295	340	358	405	460
		(inches)	(8.15)	(8.98)	(10.75)	(11.61)	(13.39)	(14.09)	(15.94)	(18.11)
Width	W1	mm	290	350	420	460	400	430	500	500
		(inches)	11.42	13.78	16.54	18.11	15.75	16.93	19.69	19.69
	W2	mm	240	290	340	380	325	355	420	420
		(inches)	9.45	11.42	13.39	14.96	12.80	13.98	16.54	16.54
	W3	mm	345	405	485	535	595	635	700	815
		(inches)	13.58	15.94	19.09	21.06	23.43	25.00	27.56	32.09
	W4	mm	298.5	362	432	476	540	578	635	749.5
		(inches)	11.75	14.25	17.01	18.74	21.26	22.76	25.00	29.51
W5	mm	29	30.5	32	35	37	40	43	48	
	(inches)	1.14	1.20	1.26	1.38	1.46	1.57	1.69	1.89	
W6	mm	30	30	40	45	45	50	50	55	
	(inches)	1.18	1.18	1.57	1.77	1.77	1.97	1.97	2.17	
W7	mm	50	65	55	60	60	65	65	70	
	(inches)	1.97	2.56	2.17	2.36	2.36	2.56	2.56	2.76	
Weight (kg)	kg	60.0	68.0	97.0	128	163	213	249	339	
	(lb)	(132)	(150)	(214)	(282)	(359)	(470)	(549)	(747)	

Note) 1. The table indicates dimensions for ANSI 150 flange.

Flange type with ANSI150 Flange

[Unit: mm (inch)]

Size 700(28inches) to 1000 mm (40 inches)

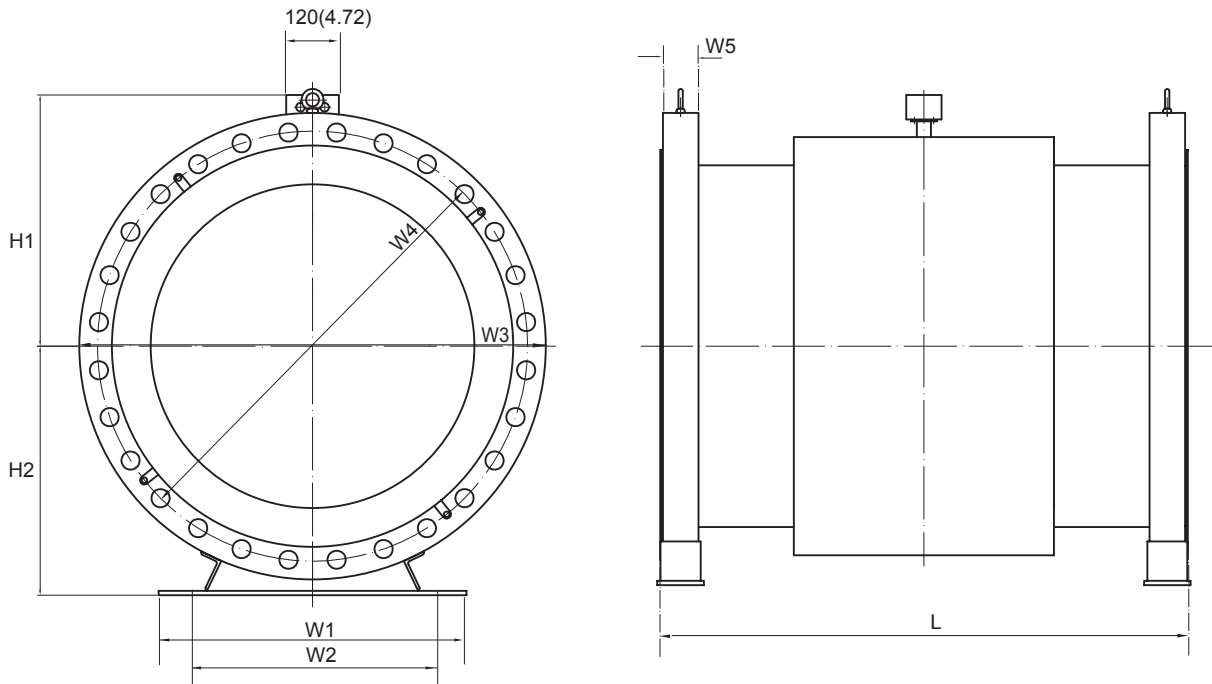

Size		mm	700	800	900	1000
		(inches)	(28)	(32)	(36)	(40)
Face to face dimension	L	mm	1100	1200	1300	1500
		(inches)	(43.31)	(47.24)	(51.18)	(59.06)
Height	H1	mm	466	516	566	616
		(inches)	(18.35)	(20.31)	(22.28)	(24.25)
	H2	mm	513	580	635	695
		(inches)	(20.02)	(22.28)	(25.00)	(27.36)
Width	W1	mm	700	700	700	900
		(inches)	27.56	27.56	27.56	35.43
	W2	mm	600	600	600	800
		(inches)	23.62	23.62	23.62	31.50
	W3	mm	925	1060	1170	1290
		(inches)	36.42	41.73	46.06	50.79
	W4	mm	864	978	1086	1200
		(inches)	34.02	38.50	42.76	47.24
W5	mm	71	81	91	91	
	(inches)	2.83	3.19	3.58	3.58	
Weight	kg	630.0	720.0	1060.0	1320.0	
	(lb)	(1389)	(1587)	(2337)	(2910)	

Note) 1. The table indicates dimensions for ANSI 150 flange.

azbil

Yamatake Corporation
Advanced Automation Company

1-12-2 Kawana, Fujisawa-shi
Kanagawa-ken, 251-8522 Japan

URL:<http://www.azbil.com>