

WaterMAG
Smart Electromagnetic Flowmeter
Detector for water measurement
Model:MGW18
User's Manual

Copyright, Notices and Trademarks

Printed in Japan - ©2006 by Yamatake Corporation All Rights Reserved

While this information is presented in good faith and believed to be accurate, Yamatake Corporation disclaims the implied warranties of merchantability and fitness for a particular purpose and makes no express warranties except as may be stated in its written agreement with and for its customer.

In no event shall Yamatake Corporation be liable to anyone for any indirect, special or consequential damages. This information and specifications in this document are subject to change without notice.

Preface

Thank you for purchasing the Yamatake Corporation WaterMAG Smart Electromagnetic Flowmeter Detector. This product is a highly reliable, high performance electromagnetic flowmeter developed based on our extensive experience in the field.

Unpacking and inspection

Unpacking

This device is a precision instrument and should be handled with care to prevent damage or breakage.

After unpacking the device, verify that the following items are included:

- The device itself
- Standard accessories

If you have any questions regarding the specifications of your WaterMAG.

Verifying the specifications

The specifications for this device are written on the nameplate of the main unit. Compare these specifications with those listed in the specification sheets, device standard specifications and model numbers, and verify that all the specifications on the nameplate are correct, paying special attention to the following:

- Detector bore diameter
- Electrode material
- Flange rating
- Grounding ring material

Inquiries

If you have any questions regarding the specifications, contact your local Yamatake representative. When making an inquiry, be sure to provide the MODEL NO. and PRODUCT NO.

Storage precautions

When storing this device before use, observe the following instructions:

- Store the device indoors at room temperature (25°C or 77°F) and humidity (65%), in a place safe from vibration or shock.
- Store the device in the same condition as it was shipped.

When storing this instrument after usage, observe the following instructions:

1. Rinse the inside of the detector with water to remove any residual fluids and then allow it to dry.
2. Tighten the display cover and terminal box cover in order to prevent moisture ingress.
3. Return the instrument to its original packing.
4. Store the device indoors at room temperature and humidity in a place safe from vibration and shock.

Safety

Introduction

Correct installation, correct operation and regular maintenance are essential to ensure safety during the use of this device. Read and understand the safety precautions described in this manual and be sure to follow the instructions on installation, operation and maintenance.

Signal words

The following symbols are used in this manual to alert you to possible hazards:

WARNING

Denotes a potentially hazardous situation which, if not avoided, could result in death or serious injury.

CAUTION

Denotes a potentially hazardous situation which, if not avoided, could result in minor injury or damage to device.

~Note *Denotes important information and guidelines for safety of personnel and protection of device.*

How this manual is organized and used

Organization and method of use

This manual explains the use of this device and its associated devices in the following order:

Chapter 1

The configuration of measuring system using this product, the structure of the detector, and the names and functions of the respective parts.

Chapter 2

Installation and wiring of the device. Persons installing this unit or the pipes or wiring should refer to this chapter.

Chapter 3

Maintenance and inspection procedures and troubleshooting. Items which require routine maintenance are explained here.

Table of Contents

Chapter 1 : Configuration and structure of the measuring system

1-1 :	System configuration.....	1-2
	Measuring system.....	1-2
1-2 :	Structure of this unit and functions of parts	1-3
1-2-1 :	Detector	1-3
	Flanged detector.....	1-3
	Detector terminal box.....	1-5

Chapter 2 : Installing the device

2-1 :	Before installing	2-2
	Criteria for selecting the installation site	2-2
2-1-1 :	Installing a flange detector.....	2-5
	Basic installation method	2-5
	Basic installation method	2-7
	Parts necessary for installation	2-9
	Selecting an installation method	2-10
	Installation on metal pipe (1).....	2-11
	Installation on metal pipe (2).....	2-12
	Electrical wiring.....	2-13
2-1-2 :	Installation of large-size detector, flange model	2-14
	Basic installation	2-14

Chapter 3 : Maintenance of the device

List of Figures & Tables

<Figures>

Figure 1-1	Remote configuration	1-2
Figure 1-2	Details of the flanged detector	1-3
Figure 1-3	Detector terminal box	1-5
Figure 2-1	Proper placement of the detector	2-3
Figure 2-2	Straight pipe section on the upstream side of the detector	2-4
Figure 2-3	Space allowance for inspections	2-4
Figure 2-4	Installation example	2-5
Figure 2-5	Flange shape	2-7
Figure 2-6	Example of incorrect mounting	2-8
Figure 2-7	Installation using grounding ring of SUS material	2-11
Figure 2-8	Installation without grounding ring	2-12
Figure 2-9	Connection using a special cable	2-13
Figure 2-10	Angle of suspension	2-14
Figure 2-11	Foundation dimensions for 200 ~ 1000 mm detector	2-14
Figure 2-12	Detector installed on a pipe	2-16

<Tables>

Table 2-1	Fastening torque	2-6
Table 2-2	Recommended internal diameters of gaskets	2-9
Table 2-3	Installation method according to material	2-10
Table 2-4	Foundation dimensions(mm)	2-14

Chapter 1 : Configuration and structure of the measuring system

Introduction

This chapter explains the configuration of measuring systems using this unit.

- The structure of this unit and the names and functions of its respective parts are explained.

1-1 : System configuration

Measuring system

Introduction

Remote: Detector and converter are installed connectly by cable.

Example of flow measurement systems

Figure 1-1 show examples of measurement systems using the device.

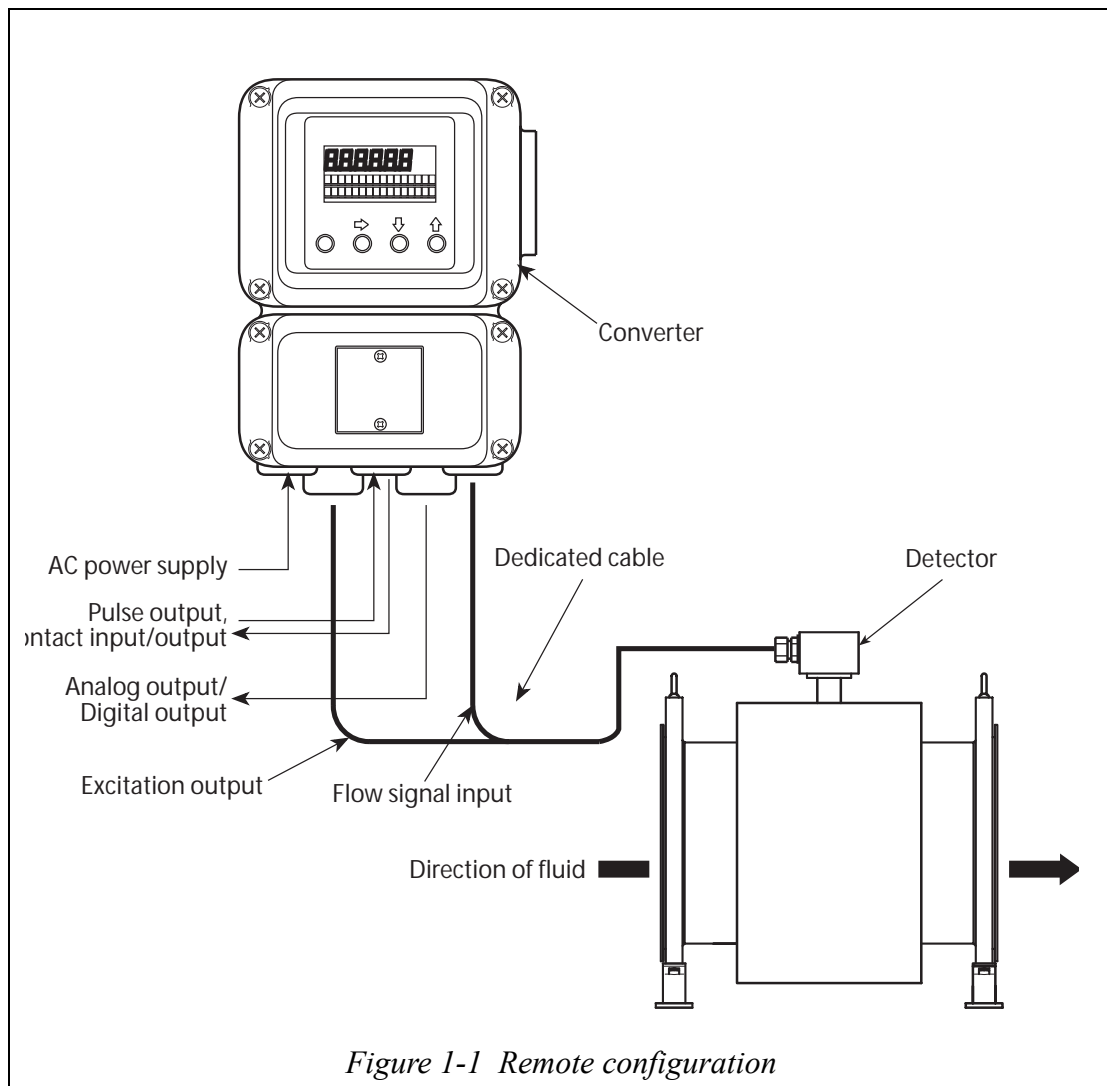

1-2 : Structure of this unit and functions of parts

1-2-1 : Detector

Explanation

The functions and structure of the device are as follows.

- When a fluid passes through the detector, the detector generates an electromotive force signal proportional to the flow rate.
- The electrodes are both mounted horizontally.

Flanged detector

Names of major parts

Figure 1-2 shows the structure of the detector and the names of its major parts.

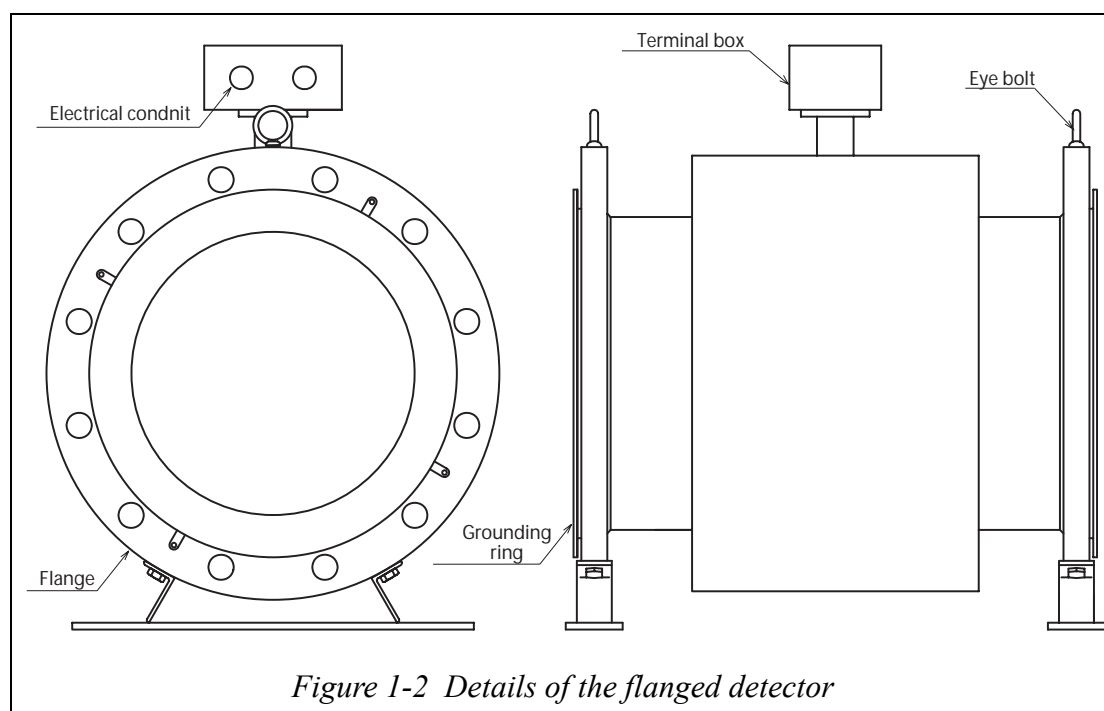

Names and functions of parts

This table explains the major parts of the detector.

Table 1-1 Names and functions of parts of the flanged detector

Name	Function
Electrical conduit	<ul style="list-style-type: none">• The excitation cable and the signal cable are wired through these conduit connections. Appropriate cable glands must be installed.
Grounding ring	<ul style="list-style-type: none">• The grounding ring protects lining erosion and connects the grounding to the body.
Terminal box	<ul style="list-style-type: none">• Houses excitation and signal terminals.
Flanges	<ul style="list-style-type: none">• Flange structure varies according to the flanges of the pipes to which the detector is to be fitted.
Terminal box cover	<ul style="list-style-type: none">• Keep the terminal box cover on during operation.

Detector terminal box

Names of parts

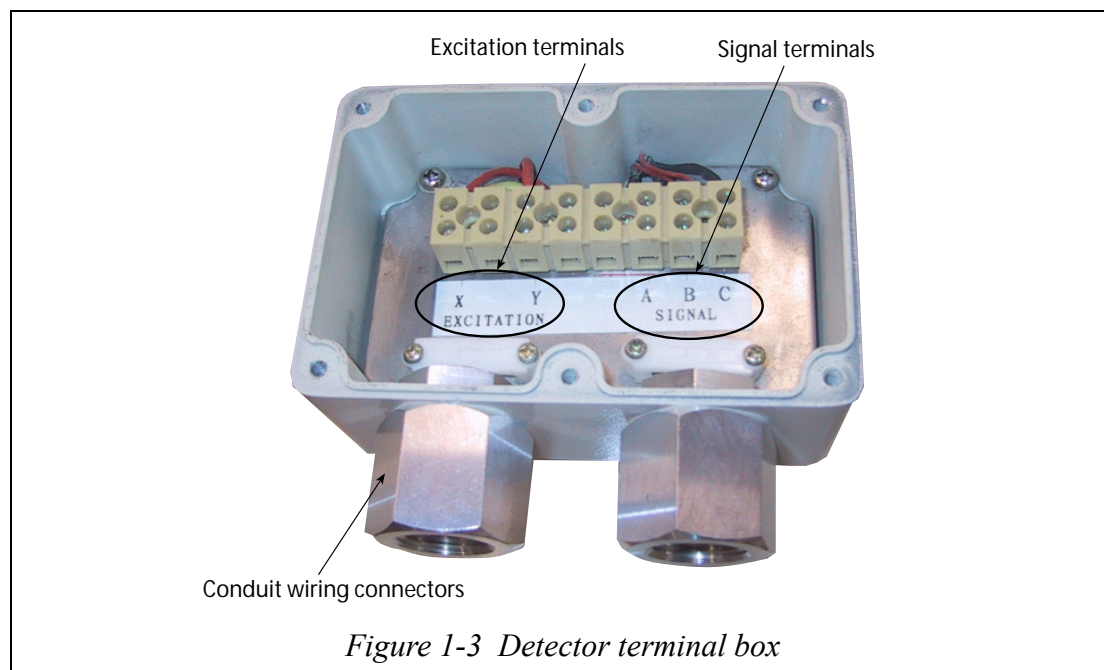

Names and explanations of parts

The table below explains the major parts of the detector terminal box.

Table 1-2 Names and explanations of parts of terminal box

Name	Function
Signal terminals	<ul style="list-style-type: none"> • These are marked A, B, and C.
Excitation terminals	<ul style="list-style-type: none"> • These are marked X and Y.
Conduit wiring connectors	<ul style="list-style-type: none"> • The excitation cable and the signal cable are wired through these connectors.

⚠ WARNING

Turn off power to the converter side before wiring, to avoid electric shock.

Chapter 2 : Installing the device

Introduction

This chapter describes the installation and wiring of this device.

The required parts and method for installing this device may vary slightly depending on the material of the grounding ring and the pipe.

Installation is explained in the following order:

- Criteria for selecting the installation environment
- An outline of the method of installing the device
- Detailed methods of installation depending on the material

2-1 : Before installing

Criteria for selecting the installation site

Introduction

In order to make full use of the functions of the device, select an optimal installation site by following the selection criteria below.

Environment

CAUTION

- Install the unit in a location with an ambient temperature of -30 to +60°C and a relative humidity of 5% to 90%. Failing to meet these requirements could cause output errors.
- Install the unit away from high-current power lines, motors and transformers to prevent damage from electromagnetic induction. Failing to meet this requirement could cause output errors.
- Do not install the unit in a location subject to severe vibration or a highly corrosive atmosphere. Failing to meet this requirement could break the neck of the detector or cause other damage.

Fluid to be measured

CAUTION

The location for your WaterMAG must satisfy the following conditions. Failing to meet these requirements could cause output errors and fluctuations.

- A location where the conductance of the fluid to be measured matches the stated specification and is more or less constant. WaterMAG is recommended to measure only water.
- A location where the fluid to be measured can be regarded as electrochemically uniform. For example, if two fluids are mixed by the time they reach the measurement point.
- A location where the distribution of suspended matter, if any, can be regarded as nearly uniform.
- The fluid listed below could cause measurement trouble. Do not use this device, therefore, even if their conductance, temperature, and pressure fall within the specifications of the device (see specifications, “device standard specifications” and “model numbers”).
 - (1) Fluids that have sufficient conductance at high temperatures but do not satisfy the conductance requirements at room temperature (about 20°C) (Examples: fatty acids and soap)
 - (2) Certain fluids that contain surfactants (Examples: rinses, shampoos, and CWM)
 - (3) Conductive adherents (Example: deposition of rosin + conductive material)
 - (4) Insulating adherents (Example: oil, kaolinite, kaolin, and calcium stearate)

Precautions to observe after installing

⚠ CAUTION

- After installing this unit, do not use it as a foothold as this can damage the unit.

⚠ WARNING

- When removing this unit, make sure there is no residual liquid or pressure inside the piping and the detector. Any residual liquid or pressure can cause injury.

Detector position

Position the detector so that its internal detector passage is continuously filled with the fluid being measured. Figure 2-1 shows examples of positions that fulfill this condition.

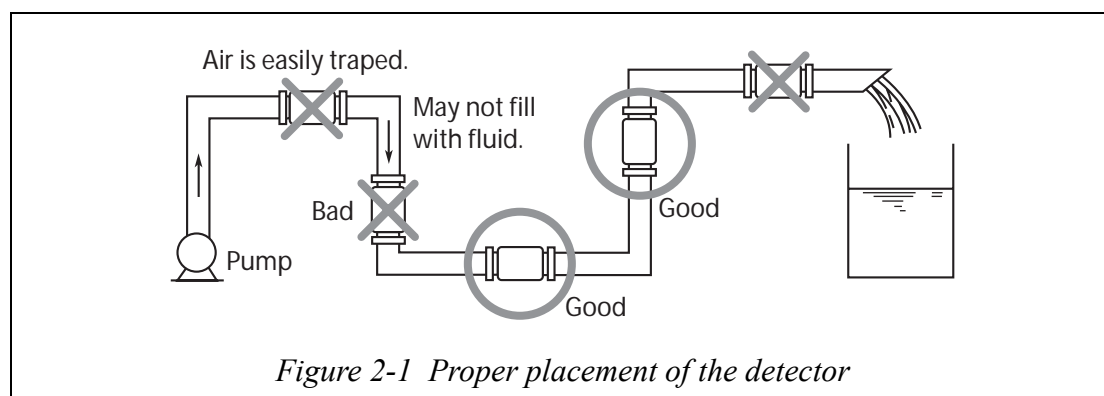

⚠ CAUTION

- Fill the pipe with liquid and install the detector in a location that satisfies the conditions circled above. If the pipe is not filled it can cause an output error.
- Install a straight pipe section between the upstream and downstream positions. For the length of the straight pipe section, refer to Figure 2-2.

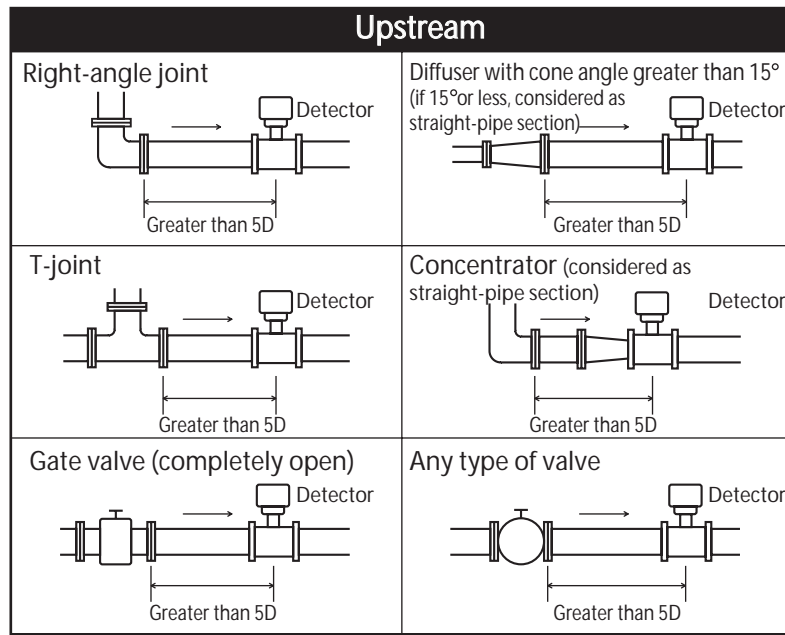

Figure 2-2 Straight pipe section on the upstream side of the detector
(D: nominal bore diameter of the detector)

- Although a pipe section is not necessary on the downstream side, secure a section of at least 2D if drift current or similar is likely.
- Select a place where there is no major pulse flow. (Install the detector in a location distant from a pump.)
- Secure the spare required for inspection of the terminal box.

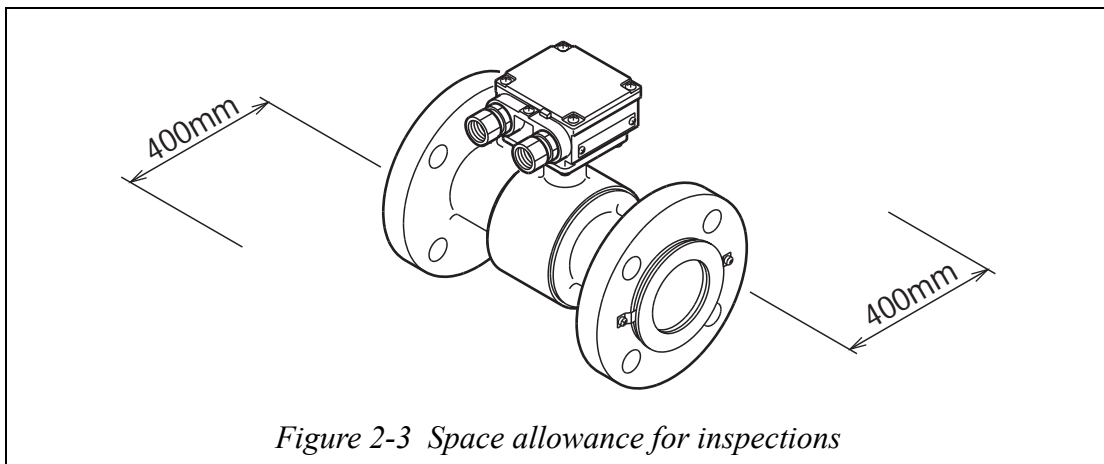

Figure 2-3 Space allowance for inspections

2-1-1 : Installing a flange detector

Basic installation method

Introduction

Figure 2-4 shows the basic method for installing the device.

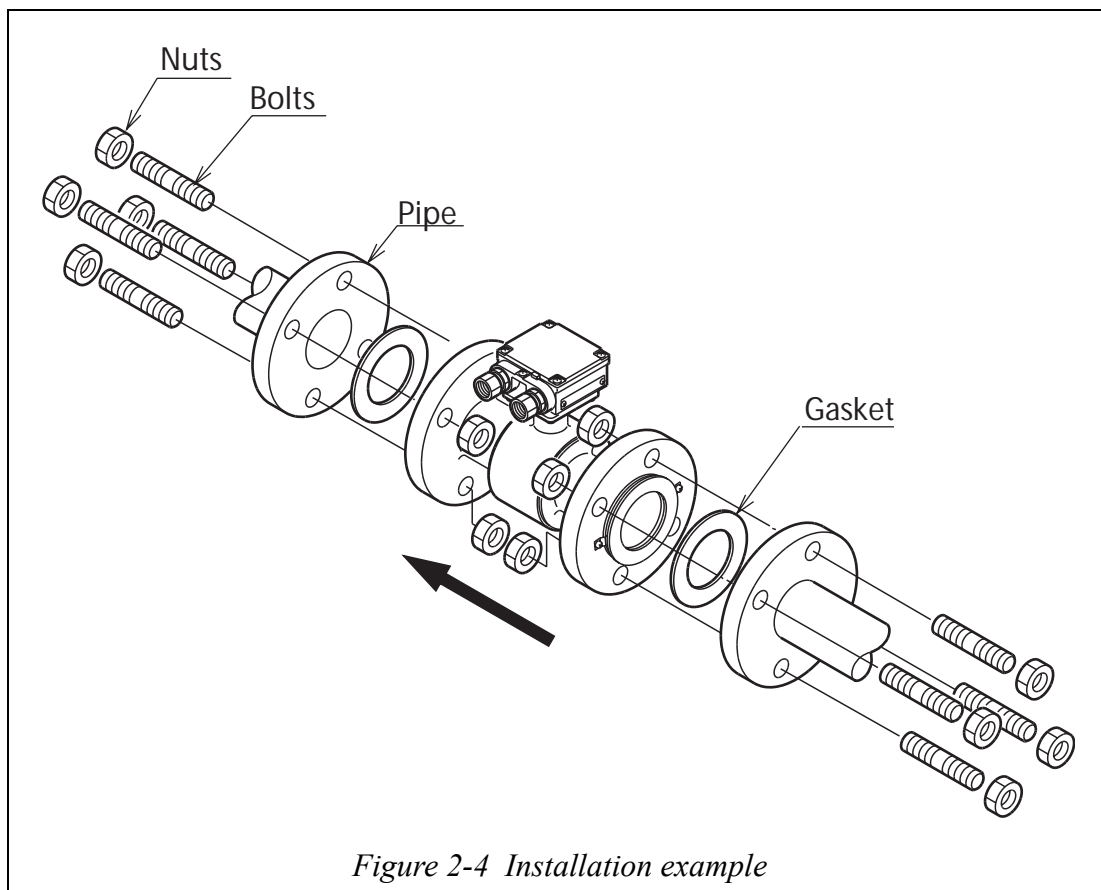

Fastening torque

CAUTION

Be careful in handling flanged detectors. Dropping it could cause injury.

WARNING

Table 2-1 shows the fastening torque for each pipe bore. Apply the prescribed fastening torque to prevent leakage.

Table 2-1 Fastening torque

Bore and flange rating		Fastening torque N•m (ft • lb)	
200 mm (8")	ANSI 150	49 ~ 59	(36 ~ 43)
	DIN PN10	42 ~ 51	(31 ~ 37)
250 mm (10")	ANSI 150	70 ~ 86	(52 ~ 63)
	DIN PN10	42 ~ 51	(31 ~ 37)
300 mm (12")	ANSI 150	81 ~ 98	(60 ~ 72)
	DIN PN10	48 ~ 58	(35 ~ 42)
350 mm (14")	ANSI 150	102 ~ 124	(75 ~ 91)
	DIN PN10	70 ~ 85	(52 ~ 62)
400 mm (16")	ANSI 150	113 ~ 137	(83 ~ 101)
	DIN PN10	77 ~ 93	(57 ~ 68)
450 mm (18")	ANSI 150	155 ~ 189	(114 ~ 139)
	DIN PN10	76 ~ 93	(56 ~ 68)
500 mm (20")	ANSI 150	153 ~ 187	(113 ~ 137)
	DIN PN10	83 ~ 101	(61 ~ 74)
600 mm (24")	ANSI 150	221 ~ 264	(163 ~ 194)
	DIN PN10	126 ~ 154	(92 ~ 113)
700 mm (28")	ANSI 150	217 ~ 264	(160 ~ 194)
	DIN PN10	134 ~ 163	(99 ~ 120)
800 mm (32")	ANSI 150	348 ~ 425	(257 ~ 313)
	DIN PN10	187 ~ 228	(138 ~ 168)
900 mm (36")	ANSI 150	362 ~ 442	(267 ~ 326)
	DIN PN10	193 ~ 235	(142 ~ 173)
1000 mm (40")	ANSI 150	375 ~ 458	(277 ~ 337)
	DIN PN10	262 ~ 320	(193 ~ 236)

Basic installation method

Flange shape

Use flanges that will maximize the area of contact with the gasket, as shown in Figure 2-5.

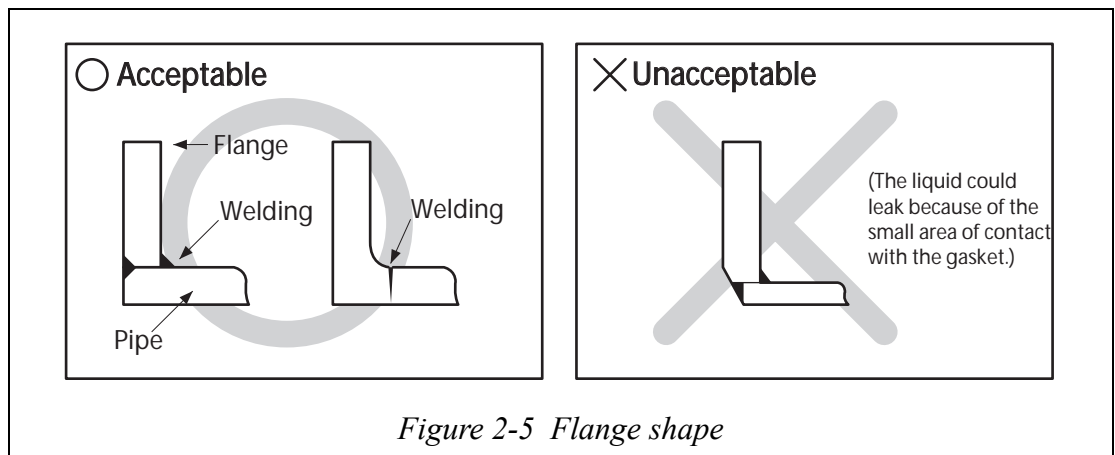

Figure 2-5 Flange shape

⚠ CAUTION

- Before installing the detector, make sure any foreign matter is flushed from the interior passage of the detector. Residual foreign matter could cause output fluctuations.
- Do not touch the electrodes or allow oil or fat to come into contact with them. This could cause output fluctuations.
- Align the flow direction mark on the detector in the direction of the liquid flow. Misalignment could result in a negative output.

⚠ CAUTION

- Never force the device between two flanges when the space is too narrow.

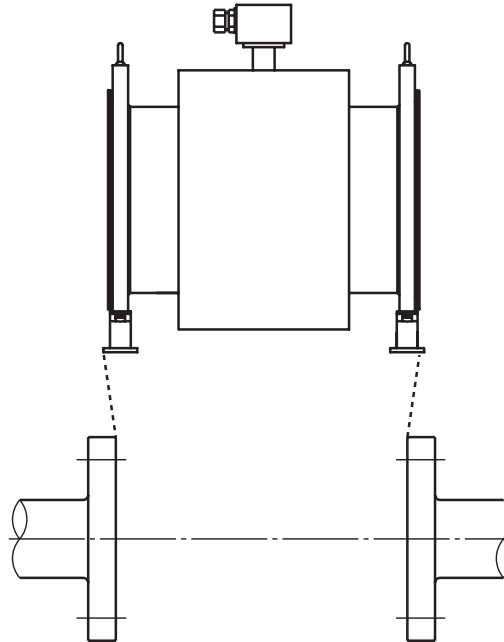

Figure 2-6 Example of incorrect mounting

⚠ WARNING

- After ensuring that the bore diameter of the pipe and that of the detector are the exactly the same, install the detector so that the gasket does not protrude into the inner bore of the pipe. Failing to do so could result in leakage or other hazards.

⚠ CAUTION

- Tighten each bolt a little at a time, apply uniform pressure to all the bolts while fastening them. If leakage does not stop on completion of fastening, make sure that the pipe is not off center, then tighten the bolts little by little. Install the detector carefully so that the fastening torque does not exceed the prescribed limit. Other wise, the unit could be damaged.

Parts necessary for installation

Introduction

The following parts are necessary for the installation of the device:

Gaskets: Gaskets are required when using the detector.

For the bore diameters of the gaskets, refer to Table 2-2.

CAUTION

- Too small a gasket diameter may affect the flow velocity distribution, resulting in inaccurate measurements.
- Too large a gasket diameter may cause leakage. Also, if there are any solids in the fluid to be measured, these may build up between the gasket and the flange, resulting in inaccurate measurements.

Table 2-2 Recommended inner diameters of gasket

Bore diameter	Inner diameter (mm)
200mm (8")	202 ±2
250mm (10")	252 ±2
300mm (12")	302 ±2
350mm (14")	352 ±2
400mm (16")	402 ±2
450mm (18")	452 ±2
500mm (20")	502 ±3
600mm (24")	602 ±3
700mm (28")	703±4
800mm (32")	803±4
900mm (36")	903±4
1000mm (40")	1003±4

Selecting an installation method

CAUTION

- The necessary materials and the method of installation vary depending on the material of the grounding ring. Select the applicable method of installation after checking the specifications of the detector to be installed and the conditions of installation. Improper installation may result in leakage or damage to the pipe flanges.

Installation method according to material

Select the appropriate installation method from the table below.

Table 2-3 Installation method according to materials

Pipe material	Grounding ring material	See page
Metal	SUS material	page 2-11
	Non-grounding ring	page 2-12

Installation on metal pipe (1)

Introduction

The installation method described in this section is to be used with the following sus grounding ring.

Pipe material: Metal

Grounding ring material: SUS material

Required parts

The following parts are required:

- Nuts and bolts
- Gaskets: For the recommended inner diameters of the gaskets, see Table 2-2 on page 2-9.

Installation procedure

Install the detector as shown in Figure 2-7. The torque level for tightening the bolts is not related to the gasket material. See Table 2-1 on page 2-6 for the appropriate torque. For the inner diameter of the gaskets, see Table 2-2 on page 2-9.

CAUTION

- A lower fastening torque may result in insufficient surface pressure between the lining and the grounding ring, resulting in leakage.

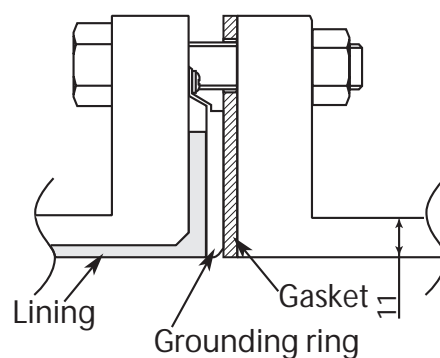

Figure 2-7 Installation using grounding ring of SUS material

Installation on metal pipe (2)

Introduction

The installation method described in this section is to be used with the case of non-grounding ring.

Pipe material: Metal

Grounding ring material: None

Required parts

The following parts are required:

- Nuts and bolts
- Gaskets: For the recommended inner diameters of the gaskets, see Table 2-2 on page 2-9.

Installation procedure

Install the device as shown in Figure 2-8. See Table 2-1 on page 2-6 for the appropriate fastening torque. For the inner diameter of the gaskets, See Table 2-2 on page 2-9.

CAUTION

- A lower fastening torque may result in insufficient surface pressure between the lining and the grounding ring, resulting in leakage.

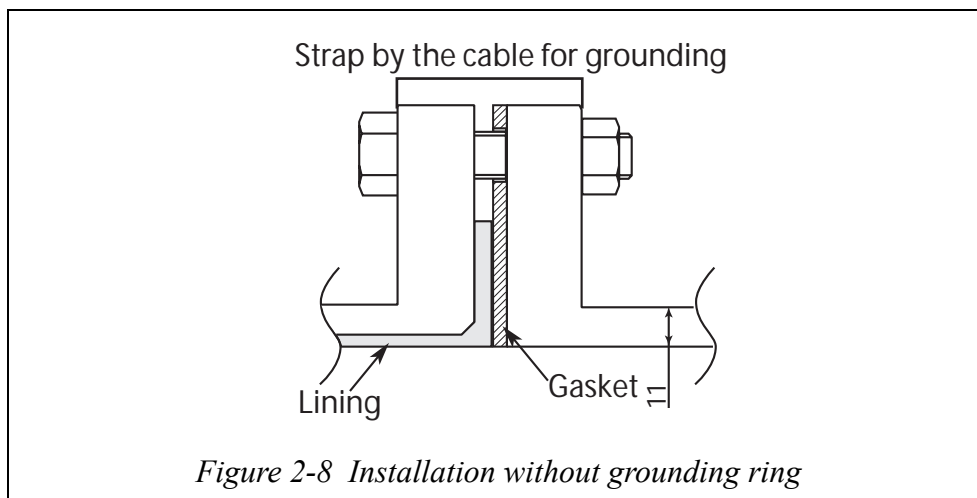

Electrical wiring

Connection of the detector and the converter (remote models)

The use of a special purpose cable (model MGA 12W) is recommended for the connection of the detector and the converter. For the details of the electrical wiring (including the special purpose cable), see the instruction manual for the converter that is to be used in combination with the detector.

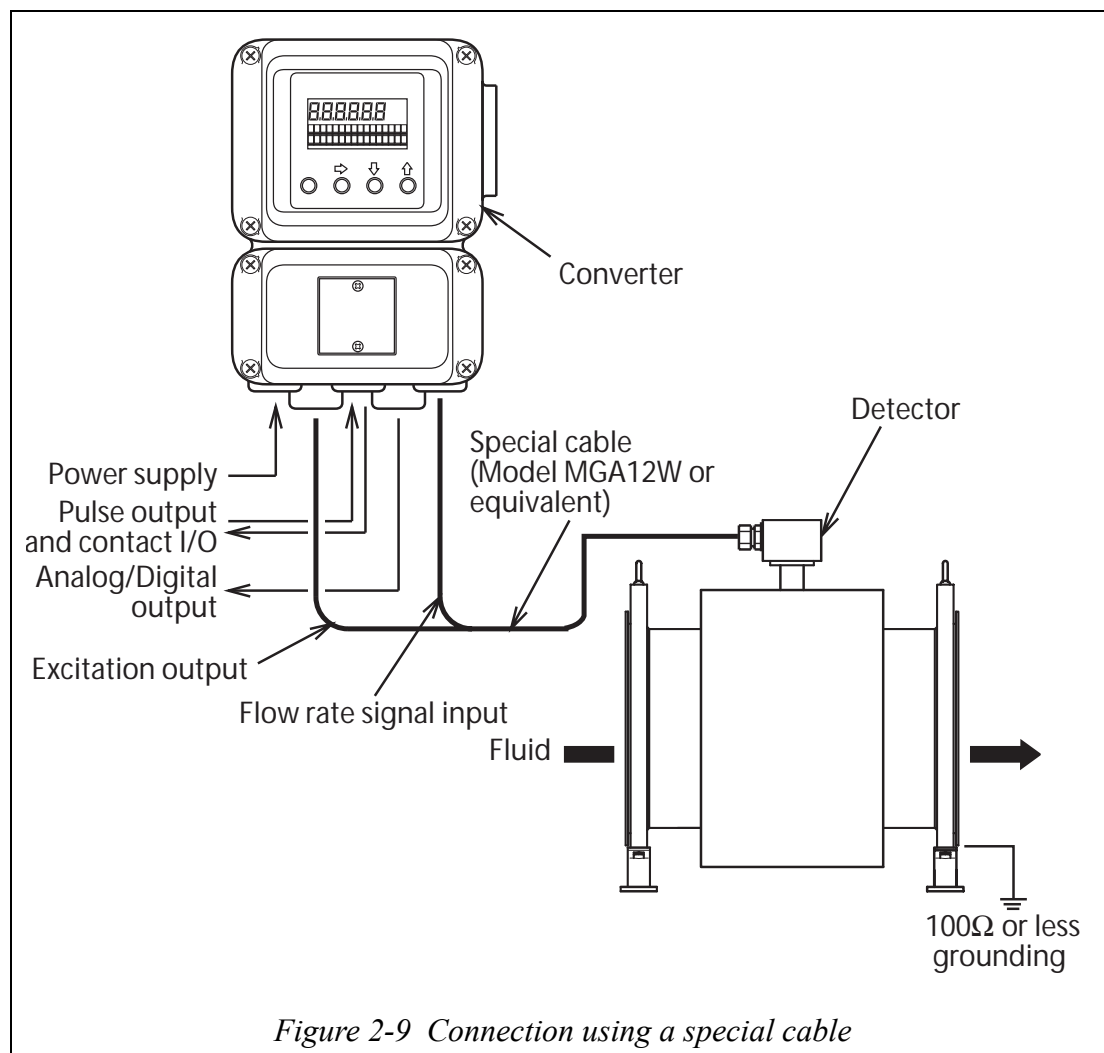

Note for the installation of the special cable

- Although the special purpose cable is shielded, install it away from any possible sources of noise, such as a large capacity transformer, motors, or motor power supplies.
- Connect 100Ω or less grounding from the detector grounding ring.

2-1-2 : Installation of large-size detector, flange model

Basic installation

Installation instructions

Make sure that the direction of flow to be measured matches the arrow on the detector body. It is easier to match flow direction before placing the detector in the pit, doing it afterwards may be awkward.

Transport

When hoisting the detector, use eye bolts or shackles. To ensure safety, the suspension angle of the slings should be within 90 degrees. (Refer to Figure 2-10.)

When placing the detector on a bracket, lower it slowly to prevent shocks. Abrupt lowering may damage the bracket.

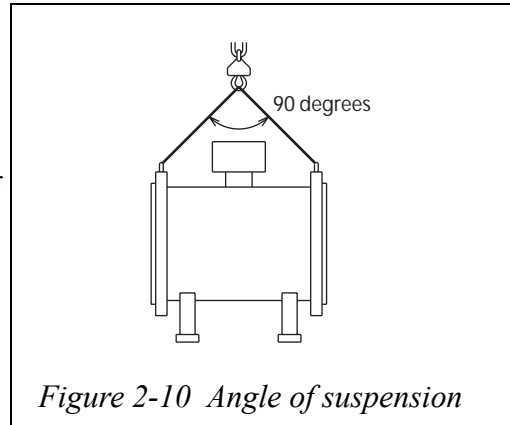

Detector positioning

Place the detector on the bracket and adjust the height with a jack. Apply the jack claws close to the support. When the position is fixed, insert a liner made of net. Under no circumstance, should water be used. While the jack provides vertical height adjustment, it cannot adjust horizontally. Ensure horizontal positioning is done before bringing the detector in.

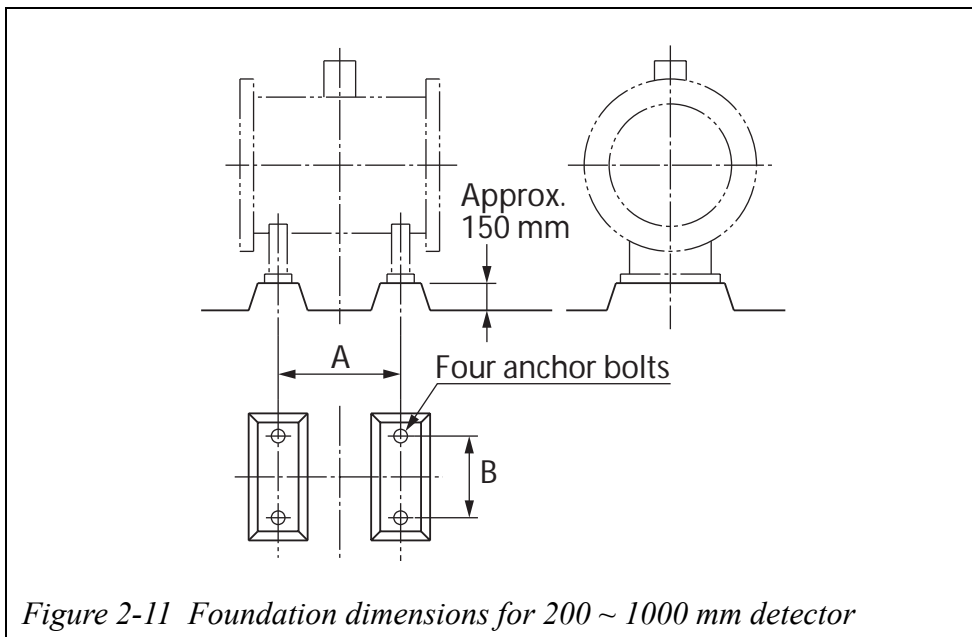
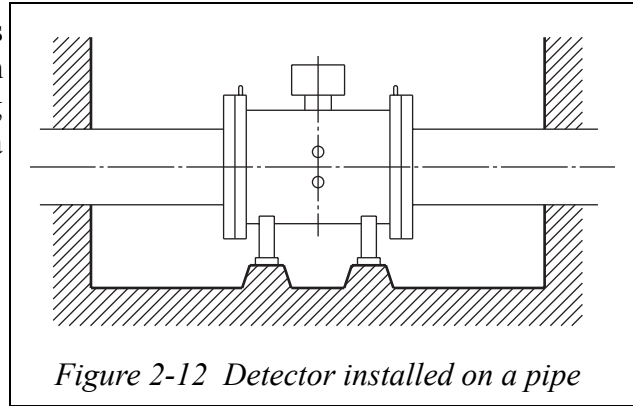

Table 2-4 Foundation dimensions (mm)

Location / Size (mm)		A	B
200 mm (8")	ANSI 150	301	240
	DIN PN10	306	
250 mm (10")	ANSI 150	400	290
	DIN PN10	404	
300 mm (12")	ANSI 150	448	340
	DIN PN10	454	
350 mm (14")	ANSI 150	495	380
	DIN PN10	504	
400 mm (16")	ANSI 150	543	325
	DIN PN10	554	
450 mm (18")	ANSI 150	540	355
	DIN PN10	552	
500 mm (20")	ANSI 150	537	420
	DIN PN10	552	
600 mm (24")	ANSI 150	582	420
	DIN PN10	602	
700 mm (28")	ANSI 150	578	600
	DIN PN10		
800 mm (32")	ANSI 150	642	600
	DIN PN10		
900 mm (36")	ANSI 150	742	600
	DIN PN10		
1000 mm (40")	ANSI 150	822	800
	DIN PN10		

Connecting and fixing the detector

When the position of the detector has been fixed, connect it to the pipe with bolts. Tighten the bolts evenly, along diagonals. The bracket should have a mortar finish applied. If the detector liner protrudes, it may cause rusting and malfunctioning. Ensure the lining is sealed by mortar.



Chapter 3 : Maintenance of the device

Introduction

For the device loop diagrams for troubleshooting and maintenance, refer to the converter user manual.

Note

Document Number:	CM2-MGW200-2001
Document Name:	WaterMAG Smart Electromagnetic Flowmeter Detector for water measurement Model: MGW18 User's Manual
Date:	Sep. 2006
Issued/Edited by:	Yamatake Corporation

Yamatake Corporation
Advanced Automation Company

1-1-32 New Stage Yokohama, Shin-urashima-cho,
Kanagawa-ku, Yokohama, Kanagawa-ken 221-0031, Japan
Tel : +81-45-461-8631
Fax : +81-45-461-2658

YAMATAKE
Savemation
Saving through Automation

<http://www.yamatake.com/>