

MagneW3000
Electromagnetic Flowmeter
Detectors
Model: KID10B/11B/12B
(Remote Type)

User's Manual

Copyright, Notices and Trademarks

Printed in Japan - © Copyright 1998 by Yamatake Corporation

While this information is presented in good faith and believed to be accurate, Yamatake Corporation disclaims the implied warranties of merchantability and fitness for a particular purpose and makes no express warranties except as may be stated in its written agreement with and for its customer.

In no event is Yamatake Corporation liable to anyone for any indirect, special or consequential damages, The information and specifications in this document are subject to change without notice.

MagneW3000 is a trademark of Yamatake Corporation.

TABLE OF CONTENTS

	<u>Page</u>
1. GENERAL	1
1.1 Scope	1
1.2 Measuring Principles of Electromagnetic Flowmeter	1
1.3 Structure of electromagnetic Flowmeter System	2
2. SPECIFICATIONS	3
2.1 Sizes 2.5 mm - 200 mm, Wafer Type	3
2.2 Sizes 250 mm - 300 mm, Flange Type	5
3. MODEL NUMBERS	7
4. NOMENCLATURE OF COMPONENTS	9
5. INSTALLATION	11
5.1 Identification by Nameplate	11
5.2 Dimension Drawings and Weight (Wafer Type)	12
5.3 Dimension Drawings and Weight (Flange Type)	13
5.4 Installation	14
5.5 Notes for Electrical Connections	26
5.6 Cable Connections	32
6. OPERATION METHOD	35
6.1 Inspection	35
6.2 Preparation for Operation	35
6.3 Operation	31
7. MAINTENANCE	34
7.1 General	34
7.2 Electrode Cleaning	34
8. TABLE OF STANDARD ACCESSORIES	38

1. GENERAL

1.1 Scope

This manual covers the operation instructions for Models KID 10B, 11B and 12B Regular-type Detectors (remote type) of MagneW 3000 Electromagnetic Flowmeters.

1.2 Measuring Principles of Electromagnetic Flowmeter

The measuring principles of the electromagnetic flowmeter are as follows:

As an electrically conductive liquid flows in a pipe which has a magnetic field in the right-angle direction with respect to the flow direction, an electromotive force is induced in the liquid in the right-angle direction with respect to both liquid flow direction and magnetic field direction by Faraday's law of electromagnetic induction. The induced voltage is proportional to the liquid flow velocity. By detecting the induced voltage with a pair of electrodes installed in the pipe, volumetric measurement of liquid flow can be made. The relationship between the liquid flow velocity and the voltage is expressed as follows:

$$E = kBd\bar{v}$$

- where,
- E: Induced emf voltage (V)
 - k: Constant
 - B: Magnetic flux density (t)
 - d: Inside diameter of pipe (m)
 - \bar{v} : Average flow velocity (m/s)

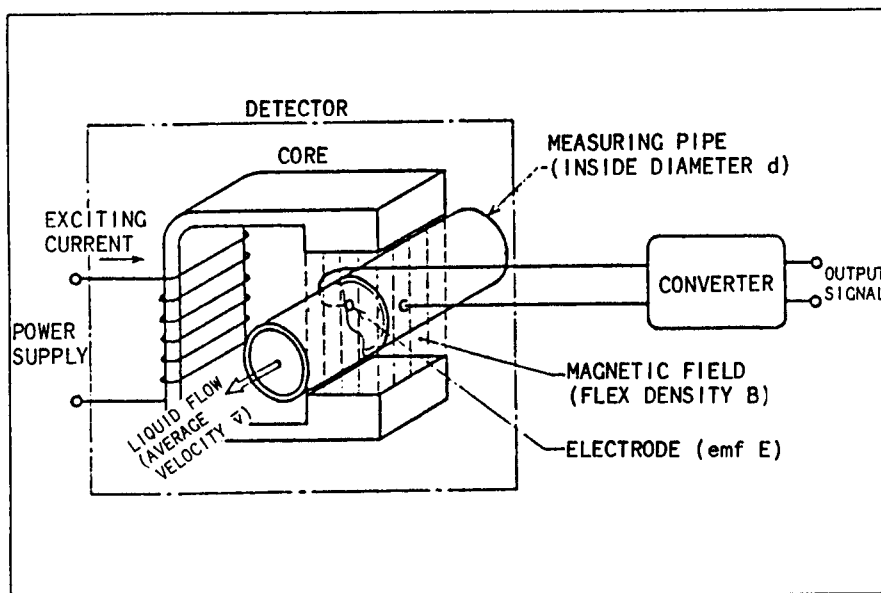

Figure 1-1. Measuring Principles of Electromagnetic Flowmeter

1.3 Structure of Electromagnetic Flowmeter System

A typical example of electromagnetic flowmeter system is shown in Figure 1-2. The detector is connected to the converter with the signal cable and exciting cable. The converter delivers a current output and a pulse output.

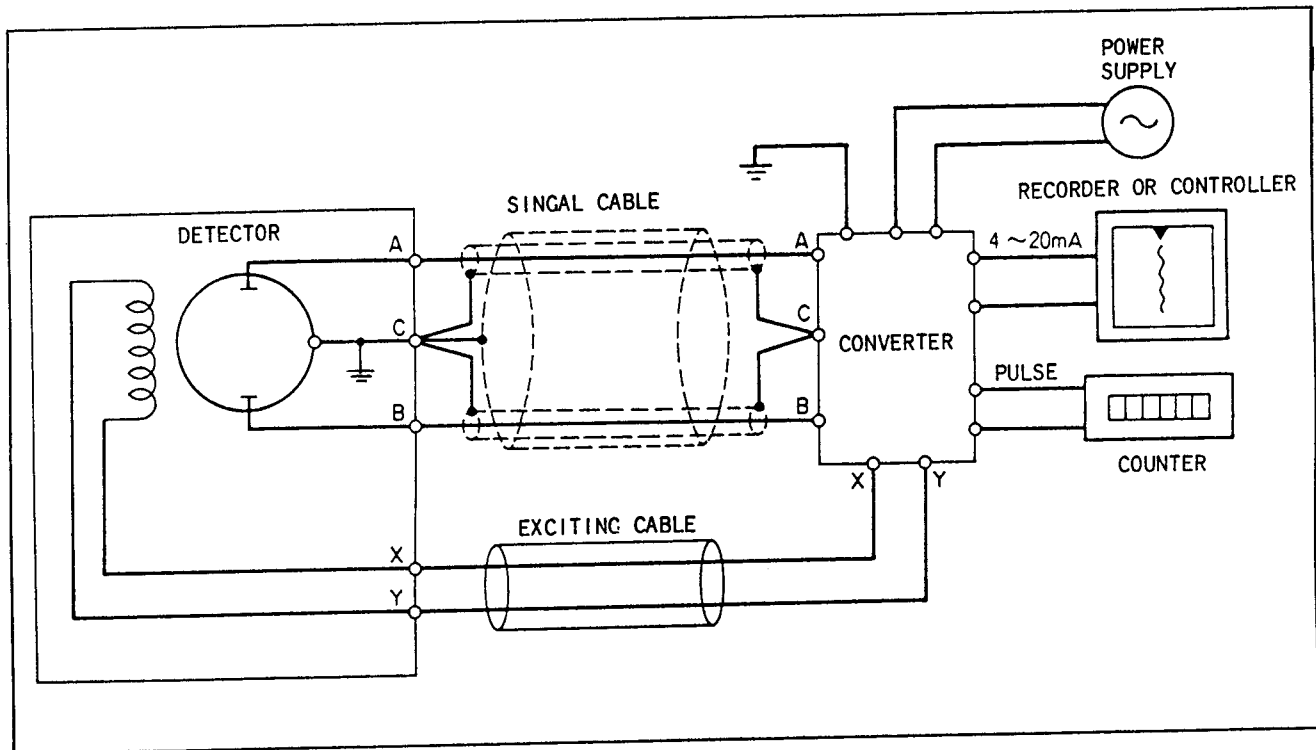

Figure 1-2. An Electromagnetic Flowmeter System

2. SPECIFICATIONS

2.1 Sizes 2.5 mm - 200 mm, Wafer Type

Table 2.1. Instrument Specifications

Item		Specifications		
Size (Diameter)		2.5, 5, 10, 15, 25, 40, 50, 80, 100, 150, 200 mm		
Materials		Case: Aluminium alloy (size 40 mm and over), cast steel (size 25 mm or less) Lining: Teflon PFA, polyurethane rubber (size 100 mm and over) Electrodes: SUS316L, hastelloy B, hastelloy C, titanium, tantalum, platinum/iridium Ground ring: SUS316, hastelloy B, hastelloy C, titanium, tantalum, platinum		
Electrodes		KID10B: External insertion type (Detachable electrodes) KID11B, KID12B: External insertion type (Detachable electrodes)		
Case	Model No.	KID10B	KID11B	KID12B
	Structure	NEMA4, IEC IP66, JIS C0920 Waterproof type	NEMA4, IEC IP67, JIS C0920, Watertight type	NEMA6, IEC IP68, JIS C0920 Submerged type
	Finish	Acryl paint	Acryl paint	Tar epoxy paint
	Finish Color	Dark beige (Munsell 10YR4.7/0.5)	Dark beige (Munsell 10YR4.7/0.5)	Black

Table 2.2. Installation Specifications

Item	Specifications
Ambient Temperature	-30 to +80°C (teflon PFA), -30 to +50°C (polyurethane rubber)
Relative Humidity	10 to 90% RH
Installation	Pincerd between flanges in process pipe line
Flange Ratings	JIS 10K, JIS 20K, JIS 30K, JIS Water Service 75M, ANSI 150, ANSI 300, DIN ND 10, DIN ND 40
Electrical Conduit Connection	G½, CM20, ½NPT internal thread
Cables (between detector and converter) For Model KIW Y-H standard cable, refer to the No. SS2-5662-0100	Signal cable: 2-core or 3-core individually-double-shielded cable (Yamatake-Honeywell standard KIW, 0.75 mm ² , outside dia. 11.4 mm), or equivalent cable (CVVS, CEEV, etc.) Cable for excitation current: Chloroprene cabtire cable 2RNCT, JIS C3327 (2 mm ² , outside dia. 11.4 mm) or equivalent cable (vinyl sheathed cable CVV JIS C3401, etc.)
Cable Length	Up to 300 meters.
Mounting Angle	The two electrodes to be in mutually horizontal position.
Grounding	JIS Class 3 grounding (Grounding resistance not greater than 100 ohms)

Table 2.3. Liquid Flow Specifications



Item	Specifications
Flow Velocity Ranges	0 ~ 0.3 m/s to 0 ~ 10 m/s
Electrical Conductivity of Liquid	300 µS/m (3 µS/cm) or over
Liquid Pressure and Temperature Ranges	<p>-40 to +160°C (teflon PFA 15~200 mm)  Teflon PFA (15~200 mm)</p> <p>-40 to +100°C (teflon PFA 2.5~10 mm)  Teflon PFA (2.5~10 mm)</p> <p>-40 to +50°C (polyurethane rubber)  Polyurethane rubber (100~200 mm)</p> 

Table 2.4. Performance Specifications (as used in conjunction with KIC Converter)

Item	Specifications		
	Span	Flow rate $\geq 25\%$	Flow rate $\leq 25\%$
Accuracy (Standard operating conditions)	1.0 to 9.999 m/s	$\pm 0.5\%$ of rate	$\pm 0.125\%$ of full scale
	0.3 to less than 1.0 m/s	$\pm 1.0\%$ of rate	$\pm 0.25\%$ of full scale
	<p>Span: 1.0 to 9.999 m/s</p>		

Table 2.5. Semi-standard Specifications

Item	Specifications
Corrosion-resistant Finish (Y138)	Y138A Corrosion-resistant finish (baked acryl finish) Y138B Corrosion-proof finish (baked epoxy finish)

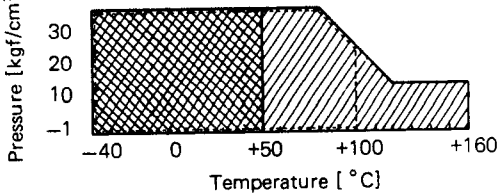
2.2 Sizes 250 mm - 350 mm, Flange Type

Table 2.5. Instrument Specifications

Size (Diameter)		250, 300, 350 (mm)		
Materials		Case:	Carbon steel (SS 41)	
		Flange:	Carbon steel (SS 41)	
		Lining:	Teflon PFA, Chloroprene rubber	
		Electrodes:	SUS316L, hastelloy C, titanium, platinum/iridium	
		Ground ring:	SUS316, hastelloy C, titanium	
Electrodes		Waterproof type:	External insertion type (Detachable electrodes)	
		Watertight type, Submerged type:	External insertion type (Non-detachable electrodes)	
Case	Model No.	KID10B	KID11B	KID12B
	Structure	NEMA4, IEC IP66, JIS C0920 Waterproof type equivalent	NEMA4, IEC IP67, JIS C0920 Watertight type equivalent	NEMA6, IEC IP68, JIS C0920 Submerged type equivalent
	Finish	Polyurethane paint	Polyurethane paint	Tar epoxy paint
	Finish Color	Dark beige (Munsell 10YR4.7/0.5)	Dark beige (Munsell 10YR4.7/0.5)	Black

Table 2.6. Installation specifications

Ambient Temperature	-30 to +80°C (teflon PFA), -30 to +60°C (Chloroprene rubber)
Relative Humidity	10 to 90% RH
Flange Ratings	JIS 10 K, JIS 20 K, JIS Water Service Class 2, ANSI 150, DIN ND 10
Electrical Conduit Connection	G 1/2, CM20, 1/2 NPT Internal thread
Cables (Between detector and converter)	Signal cable: 2-core individually-double-shielded cable (Yamatate-Honeywell standard KIW, 0.75 mm ² , outside dia. 11.4 mm), or equivalent cable (CVVS, CEEV, etc.) Cable for excitation current: Chloroprene cabtire cable 2RNCT, JIS C3327 (2 mm ² , outside dia. 11.4 mm) or equivalent cable (vinyl sheathed cable CVV JIS C3401, etc.)
Cable Length	Up to 300 meters: (Cable length is limited by detector size and electrical conductivity of measured liquid. For details, refer to the specification sheet for the dedicated cables for MagneW "SS2-5662-0100.)
Mounting Angle	The two electrodes to be in mutually horizontal position.
Grounding	JIS Class 3 grounding (Grounding resistance not greater than 100 ohms)

Table 2.7. Liquid Flow Specifications

Flow Velocity Ranges	0 to 0.1 m/s to 0 to 10 m/s	
Electrical Conductivity of Liquid	3 μS/cm or over	
Liquid Pressure and Temperature Ranges	<p style="text-align: center;">Teflon PFA</p>	<p style="text-align: center;">Chloroprene rubber</p>

Table 2.8. Performance specifications

Accuracy	±0.5% of rate (For more information, please refer to the spec. sheets of the converter)
-----------------	---

Table 2.9. Semi-standard Specifications

Corrosion-resistant Finish (Y 138 A, B)	Corrosion-resistant finish (Y 138 A): Baked acryl finish Corrosion-proof finish (Y 138 B): Baked epoxy finish
--	--

3. MODEL NUMBERS

3.1 Table of Detector Model Numbers (Wafer Type)

Basic Model No.	Selections								Applicable Sizes											Description
	Flowmeter Size	Lining	Electrodes	Flange Standards & Pressure Rating	Ground Ring	Conduit Connection	Options I	Options II	2.5mm	5 mm	10 mm	15 mm	25 mm	40 mm	50 mm	80 mm	100 mm	150 mm	200 mm	
									I	II	III	IV	V	VI	VII	VIII				
KID 10B									○	○	○	○	○	○	○	○	○	○	○	Remote type (waterproof)
KID 11B									○	○	○	○	○	○	○	○	○	○	○	Remote type (watertight)
KID 12B											○	○	○	○	○	○	○	○	○	Remote type (submerged type)
---	0002								○											2.5mm
---	0005								○											5 mm
---	0010									○										10 mm
---	0015										○									15 mm
---	0025											○								25 mm
---	0040												○							40 mm
---	0050													○						50 mm
---	0080														○					80 mm
---	0100															○				100 mm
---	0150																○			150 mm
---	0200																	○		200 mm
		P							○	○	○	○	○	○	○	○	○	○	○	Teflon PFA
		Q															○	○		Polyurethane rubber
		L							○	○	○	○	○	○	○	○	○	○	○	SUS316L
		B							○	○	○	○	○	○	○	○	●	●	●	Hastelloy B
		C							○	○	○	○	○	○	○	○	●	●	●	Hastelloy C
		K							○	○	○	○	○	○	○	○	●	●	●	Titanium
		T							○	○	○	○	○	○	○	○	●	●	●	Tantalum
		P							○	○	○	○	○	○	○	○	●	●	●	Platinum/iridium
		11							●	●	○	○	○	○	○	○	○	○	○	JIS 10K
		12							●	●	○	○	○	○	○	○	○	○	○	JIS 20K
		13							●	●	○	○	○	○	○	○	○	○	○	JIS 30K
		14							○	○	○									For JIS 10/20K, 10 mm flanges
		15							○	○	○									For JIS 30K, 10 mm flanges
		21							●	●	○	○	○	○	○	○	○	○	○	ANSI 150
		22							●	●	○	○	○	○	○	○	○	○	○	ANSI 300
		31														○	○	○		JIS water service 75M
		41							●	●	○	○	○	○	○	○	○	○	○	DIN ND10
		43							●	●	○	○	○	○	○	○	○	○	○	DIN ND40
		44							○	○	○									For DIN ND10/40, 10 mm flanges
		S							○	○	○	○	○	○	○	○	○	○	○	SUS316
		B							○	○	○	○	○	○	○	○	●	●	●	Hastelloy B
		C							○	○	○	○	○	○	○	○	●	●	●	Hastelloy C
		K							○	○	○	○	○	○	○	○	●	●	●	Titanium
		T							○	○	○	○	○	○	○	○	●	●	●	Tantalum
		P							○	○	○	○	○	○	○	○	●			Platinum
		V							○	○	○	○	○	○	○	○	○	○	○	G½ Internal thread
		W							○	○	○	○	○	○	○	○	○	○	○	CM20 Internal thread (Note 1)
		Y							○	○	○	○	○	○	○	○	○	○	○	½ NPT Internal thread (Note 1)
		-X							○	○	○	○	○	○	○	○	○	○	○	Without watertight gland
		-1							○	○	○	○	○	○	○	○	○	○	○	With SUS304 watertight gland
		-2							○	○	○	○	○	○	○	○	○	○	○	With plastic watertight gland
		X							○	○	○	○	○	○	○	○	○	○	○	None
		A							○	○	○	○	○	○	○	○	○	○	○	SUS304 bolts and nuts
		B							○	○	○	○	○	○	○	○	○	○	○	Carbon steel bolts and nuts

Legends:

- ... Applicable
 - ... Applicable to teflon lining.
Not applicable to polyurethane lining.
 - ⊙ ... Applicable when mating flanges are 15 mm.
- Note 1) Watertight gland is not selectable.

3.2 Table of Detector Model Numbers (Flange Type)

Basic Model No.	Selections							Applicable Sizes						Description		
	Flowmeter Size	Lining	Electrodes	Flange Standards & Pressure Rating	Ground Ring	Conduit Connection	Options I	Option II	250mm	300mm	350mm	400mm	500mm		600mm	
	I	II	III	IV	V	VI	VII	VIII								
KID 10B									○	○	○	○	○	○	Remote type (water-proof)	
KID 11B									○	○	○	○	○	○	Remote type (water-tight)	
KID 12B									○	○	○	○	○	○	Remote type (submerged type)	
	-0250								○						250mm	
	-0300									○					300mm	
	-0350										○				350mm	
	-0400											○			400mm	
	-0500												○		500mm	
	-0600													○	600mm	
		P							○	○	○	○			Teflon PFA	
		R							○	○	○	○	○	○	Chloroprene rubber	
			L						○	○	○	○	○	○	SUS 316 L	
			C						●	●	●	●			Hastelloy C	
			K						●	●	●	●			Titanium	
			P						●	●	●	●			Platinum / iridium	
				11					○	○	○	○	○	○	JIS 10K	
				12					●	●					JIS 20K	
				21					○	○	○	○	○	○	ANSI 150	
				31					○	○	○	○	○	○	JIS Water Service Class 2	
				41					○	○	○	○	○	○	DIN ND10	
					S				○	○	○	○	○	○	SUS 316	
					C				●	●	●	●			Hastelloy C	
					K				●	●	●	●			Titanium	
						V			○	○	○	○	○	○	G 1/2	
						W			○	○	○	○	○	○	CM20 internal thread	Water-tight gland is not available.
						Y			○	○	○	○	○	○	1/2 NPT internal thread	
							-X		○	○	○	○	○	○	Without water-tight gland	
							-1		○	○	○	○	○	○	With brass (plating Ni) water-tight gland	
							-2		○	○	○	○	○	○	With plastic water-tight gland	
							X		○	○	○	○	○	○	None	

Legends:
 ○...Applicable
 ●...Applicable to teflon lining.
 Not applicable to chloroprene rubber lining.

4. NOMENCLATURE OF COMPONENTS

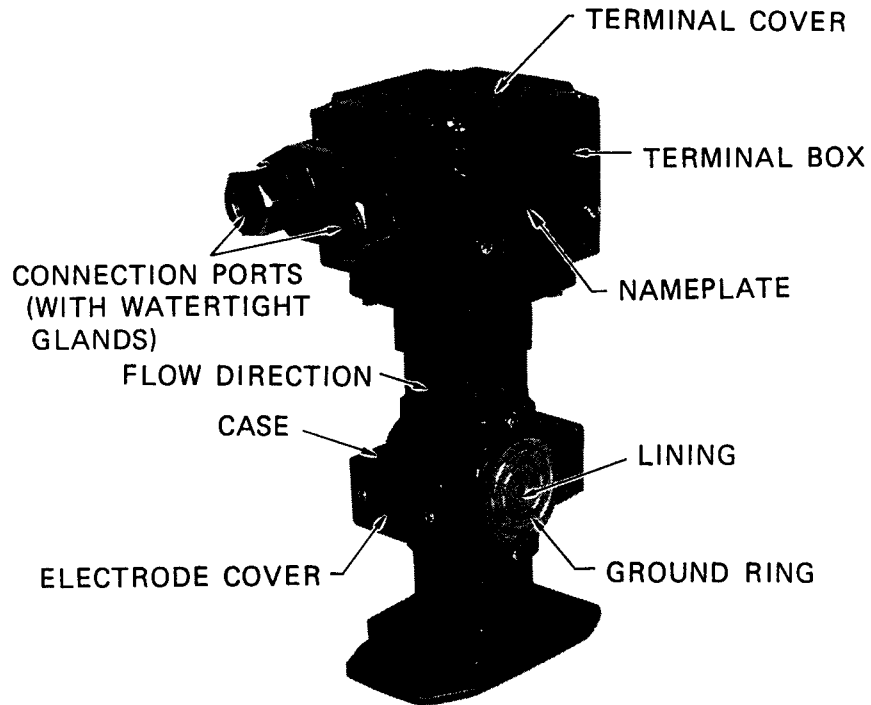

Fig. 4-1. Nomenclature of Remote-type Detector (Size 2.5 mm - 25 mm)

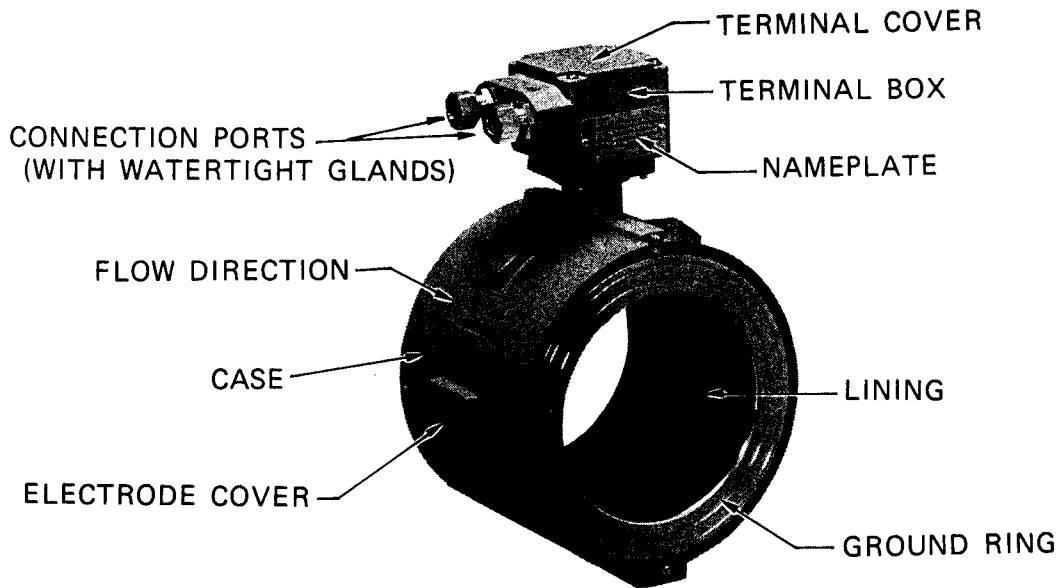

Figure 4-2. Nomenclature of Remote-type Detectors (Size 40 mm - 200 mm)

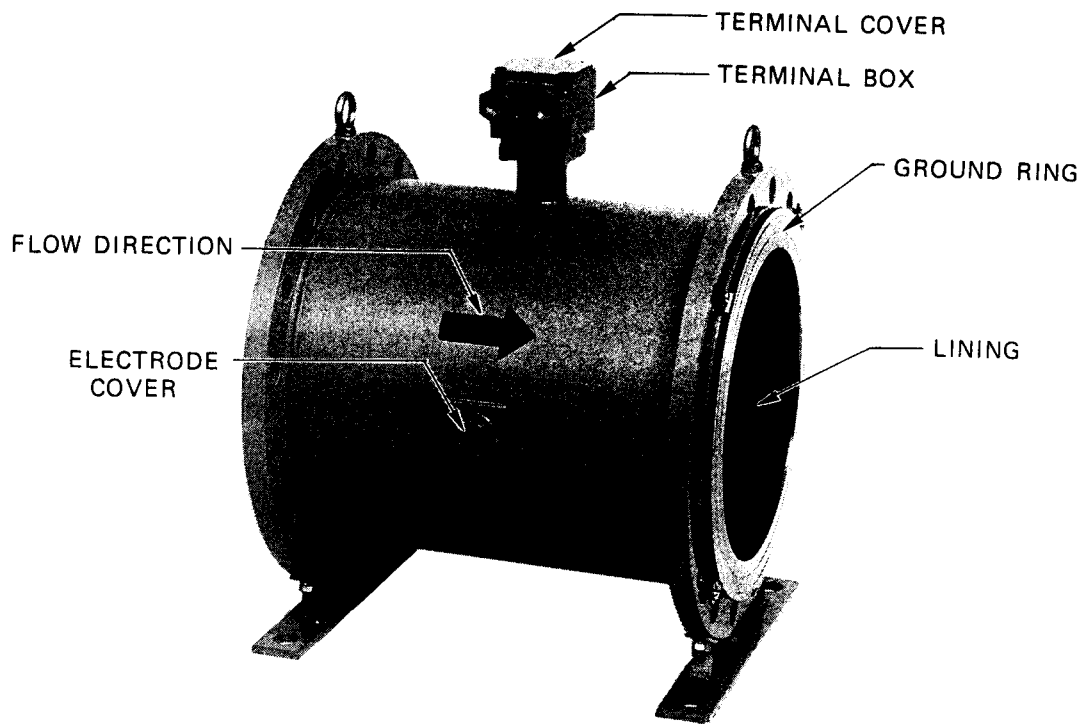

Figure. 4-3. Nomenclature of Remote-type Detectors
(Sizes 250 mm - 350 mm)

5. INSTALLATION

5.1 Identification by Nameplate

The major identification and specification items of the detector are indicated on the nameplate. Before installing the detector, confirm referring to the nameplate that the detector is the correct one for the process. (When asking your Yamatake-Honeywell agent any questions on the detector, please mention the model number (MODEL), products number (PROD), and detector constant (EX) which are indicated on the nameplate.)



Figure 5-1. Nameplate

5.2 Dimensions and Weights (Wafer Type)

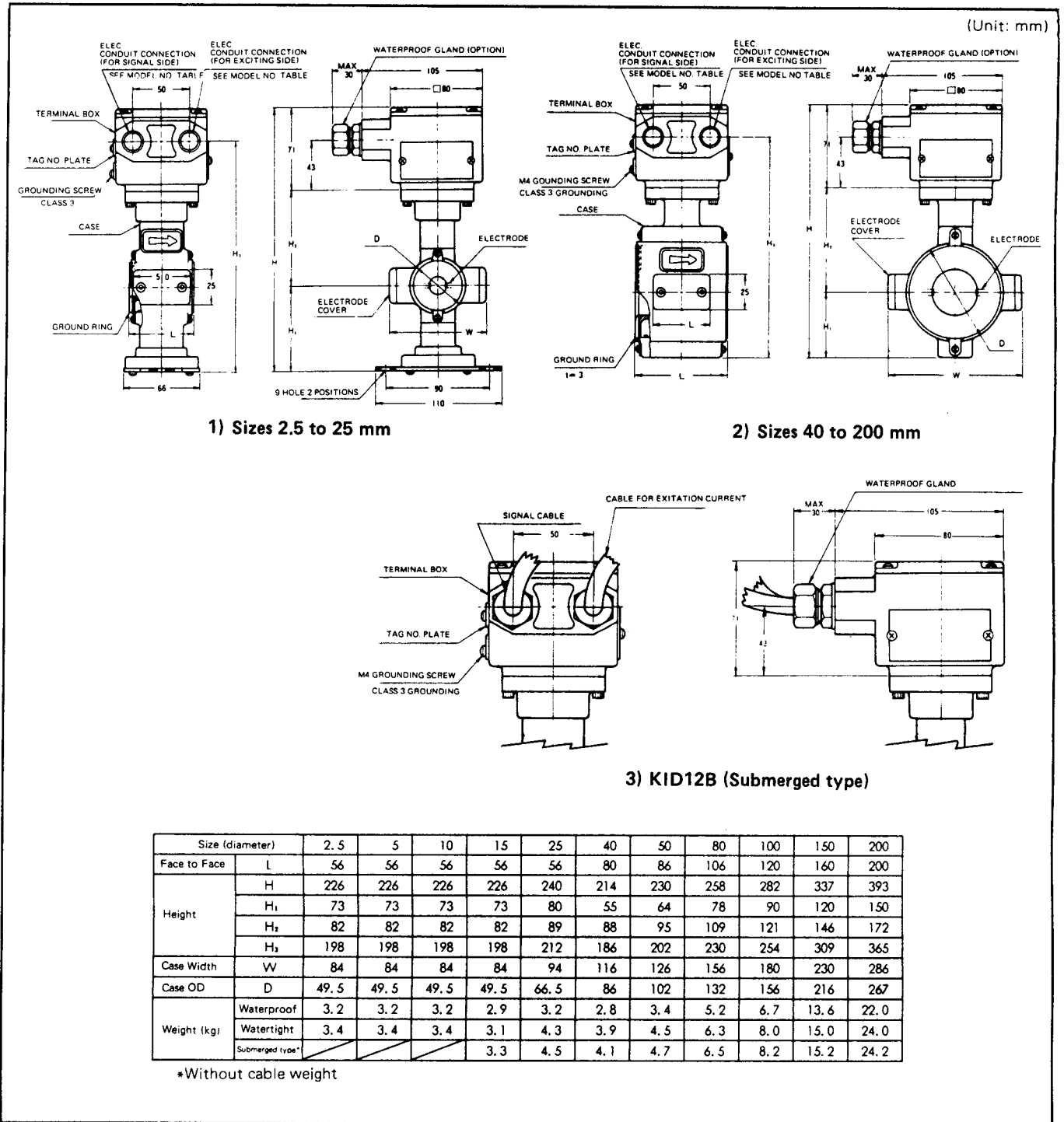

Figure 5-2

5.3 Dimensions and Weight (Flange Type)

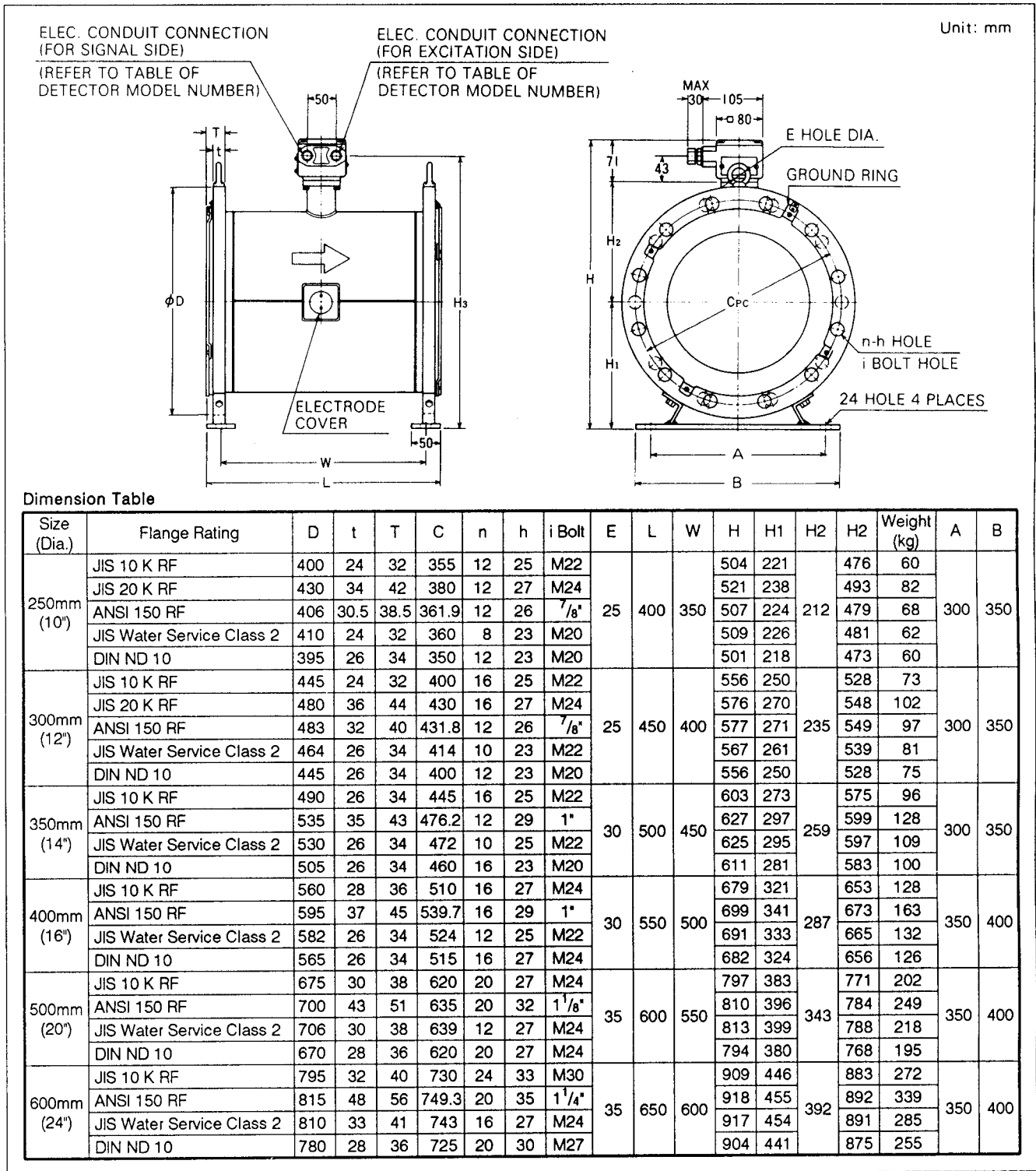

Figure 5-3

5.4 Installation

1) Notes for Installation

The types of case structures are as shown in the below table.

Case Structure	Place of Use
Splashproof type	General outdoor use
Ingressionproof type	Place where detector pipe section is submerged intermittently
Submerged type	Place where detector pipe section is submerged constantly

When installing the detector, pay attention to the following points:

- a) Ambient temperature must be within the following ranges:
 - Teflon PEA lining: -30 to +80°C
 - Polyurethane lining: -30 to +50°C
- b) Ambient humidity must be within 10 to 90 % RH
- c) The inside space of the detector must be always filled with the measured liquid.

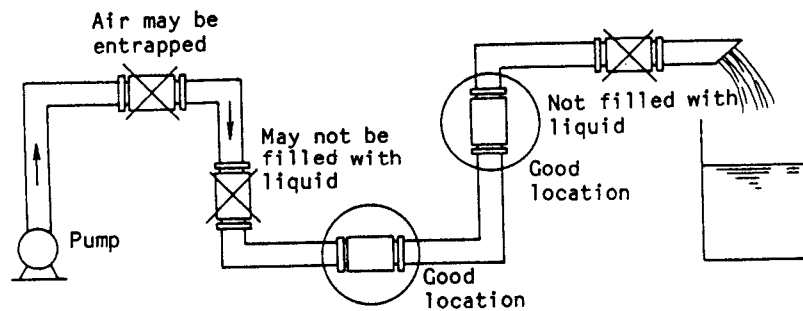

Figure 5-4. Installation of Detector

- d) Provide a straight pipe section at the upstream and downstream sides of the detector.

Upstream side		Downstream side
<p>90° bent</p> 	<p>Expander pipe of cone angle 15° or over (If angle is less than 15°, the section can be regarded as a straight pipe section.)</p> 	<p>2D or over</p>
<p>Tee</p> 	<p>Reducer pipe (Can be regarded as a straight pipe section.)</p> 	
<p>Sluice valve full-open</p> 	<p>Other valves</p> 	

Figure 5-5. Straight Pipe sections at Upstream and Downstream Sides of Detector (D: Nominal diameter of detector)

- e) Select a place where the flow does not pulsate (a place sufficiently apart from the pump).
- f) Avoid, whenever avoidable, a place where the instrument is subjected to direct sunlight, rain, or other adverse weather.
- g) Avoid a place where the instrument is subjected to electromagnetic interference. Select a place sufficiently apart from heavy duty cables, motors, transformers or other electrical devices.
- h) Avoid a place where the instrument is subjected to mechanical vibration or corrosive atmosphere.
- i) Provide sufficient spaces for maintenance of electrodes and inspection of terminals.

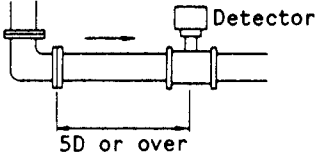
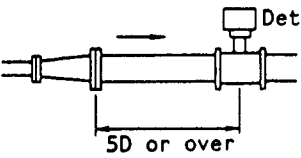
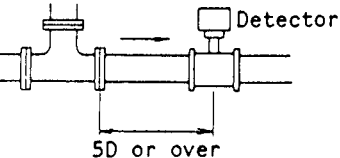
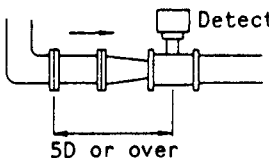
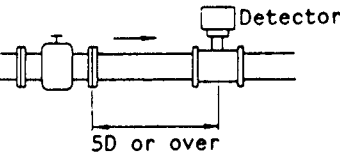
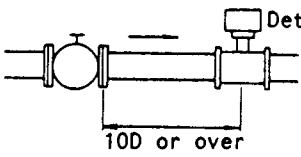
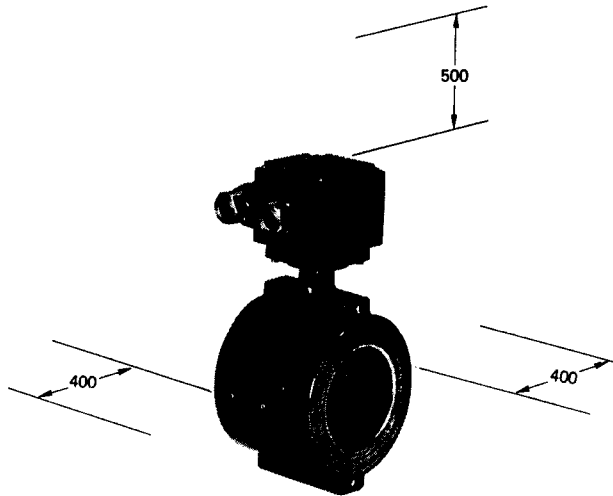

Figure 5-6. Space for Maintenance

j) Check of piping

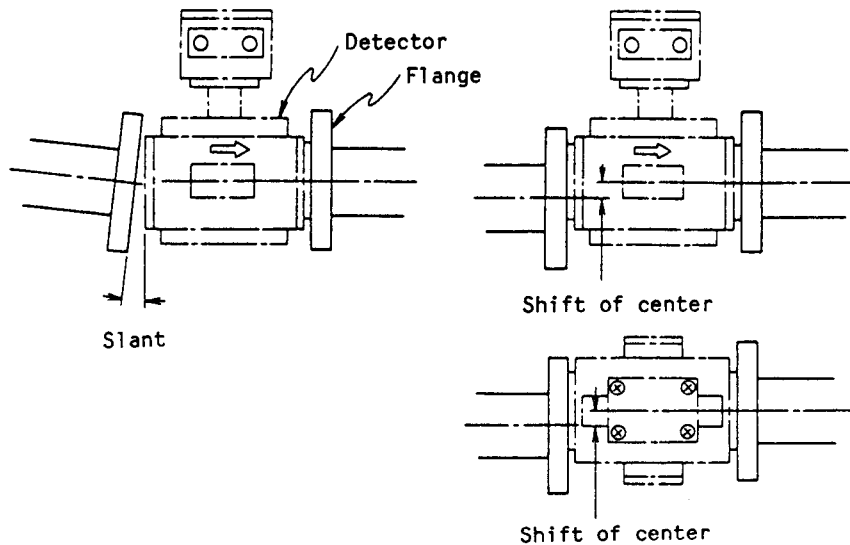

Figure 5-7. Check of Piping

- o Check that piping has not slant or shift of center. (Refer to Figure 5-7)
- o Be sure to flush the piping to eliminate foreign matter from the piping inside before installing the detector.

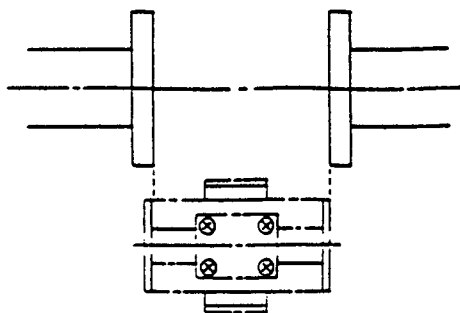

Figure 5-8

- o Do not forcibly insert the detector in an insufficient face-to-face space of piping. (Refer to Figure 5-8)
- k) Align precisely the inner diameters of piping and detector, and pay attention so that no gasket is extruded into the piping.
- l) When the measured liquid is highly viscous, it is recommendable to install the process pipe vertically in order to make the flow symmetrical with respect to the axis.
- m) Install the detector in a position where the measured liquid as an electrical conductivity required for measurement and where electrical conductivity is uniformly distributed.
- n) Install the detector in a position where electrochemical properties of the measured liquid are practically uniform.
- o) When the measured liquid contain solid suspension, install the detector in a position where solid suspension is uniformly distributed.

2) Mounting Method

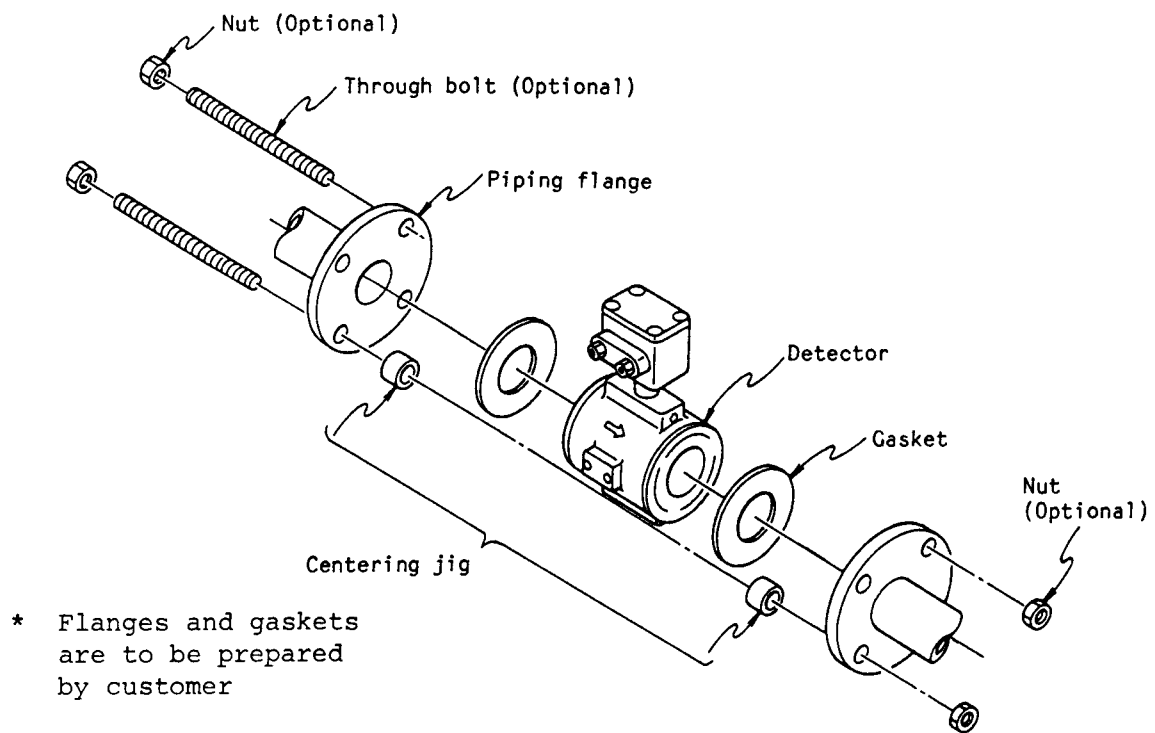

Figure 5-9.. Mounting Method

- a) Let the detector's flow direction conform with the fluid flow direction.
- b) To prevent shift of the centers between the piping and the detector, pass the centering jigs onto the through bolts and set the detector placed on or pincer between the jigs.

When the pipe size is ANSI 150, diameter 15 mm or smaller, no brackets are supplied. Install the detector in such manner that it is directly contact with the through-bolts.

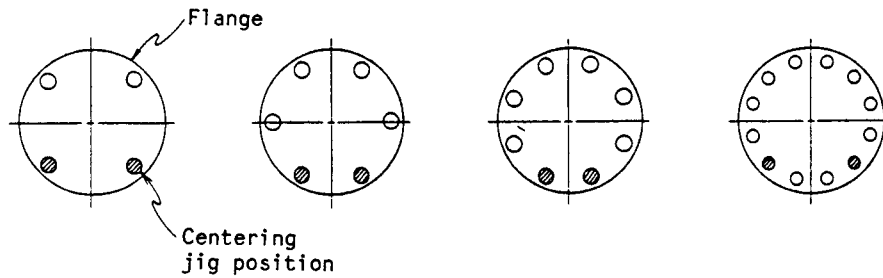

Figure 5-10-1. Horizontal Mounting (Use two jigs for each of the right and left flanges.)

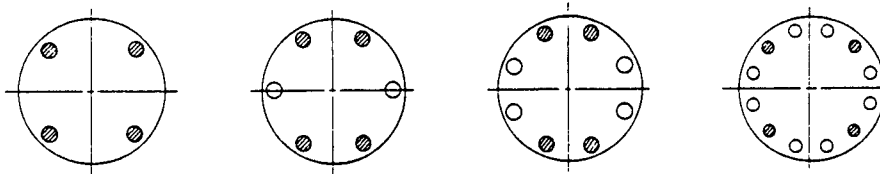

Figure 10-2. Vertical Mounting (Use for jigs for the lower flange.)

- c) The flange bolt holes and the bolt hole pitch circles have certain dimension tolerances. Therefore, it is possible that the centers are slightly shifted even when the centering jigs are used. Align the centers as accurately as possible with your skill.

3) Installation

In order to prevent any fluid leakage the material of both pipings and ground rings should be identified before installing MagneWs. Follow the instructions below.

- 3)-1 When the wet ring is made of stainless steel (SUS316): gaskets must be used to make the installation tight.
- 3)-1-1 When installing MagneWs onto metal pipings: use gaskets made of joint sheet or Teflon. Rubber gaskets should not be used.

Mount the gasket as shown in Figure 5-11 and fasten it with the supplied through bolt and nut employing an adequate torque listed in Table 5.1 to provide a complete seal between the flange and gasket and gasket and wet ring and between the ground ring and lining.

When using gaskets other than recommended, follow instructions as shown in Table 5.1 and Figure 5-1.

Note: Because of its smaller gasket factor, the rubber gasket can provide the liquid seal between the flange and gasket and between gasket and ground ring with a fastening torque smaller than those of joint sheet and Teflon gaskets. When providing seal between the ground ring and lining, however, the rubber gaskets should be fastened with an adequate torque strictly in accordance with Table 5.1.

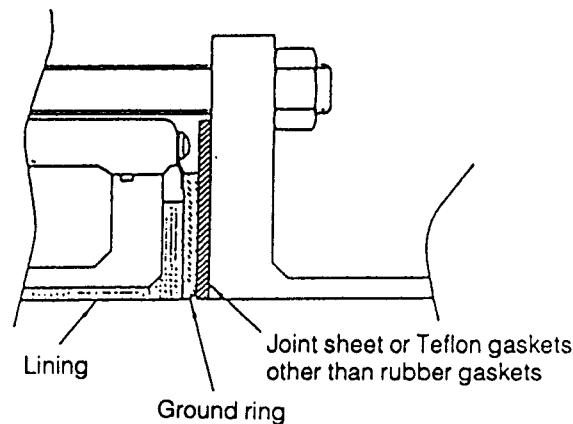

Figure 5-11. Installation onto Metal Piping

- 3)-1-2 When installing MagneWs onto PVC pipings, the same instructions as shown in above 3)-1-1 should be observed. The following instructions should also be followed.
 - (1) Support PVC pipings using something like a ladder so that no load should be imposed on the pipings.
 - (2) When the PVC pipings may be distorted or damaged, put a metal protection fitting as shown in Figure 5.11 on the face of the PVC flange before fastening.

- (3) When fastening a rubber gasket with lower torque than specified, fix another rubber gasket of 0.5 to 1.0 mm thickness (see Figure 5-2) between the lining and ground ring as illustrated in Figure 5-13 before fastening. (Because a rubber gasket having relatively small gasket factor is inserted between the flange and ground ring and between the ground ring and lining, a complete fluid seal is provided with lower fastening torque.)

Table. 5.1. Fastening Torque

2.5A - 15A	13 to 18N·m (130 to 180kgf·m)
25A	20 to 30N·m (200 to 300kgf·m)
40A 50A 80A	30 to 50N·m (300 to 500kgf·m)
100A	50 to 70N·m (500 to 700kgf·m)
150A	80 to 100N·m (800 to 1000kgf·m)
200A	90 to 100N·m (900 to 1000kgf·m)

Table 5.2. Gasket Size

Port size Size	2.5A	5A	10A	15A	25A	40A	50A	80A	100A	150A	200A
Inner dia.	8	8	12	18	28	44	54	84	104	152	200
Outer dia.	43	43	43	43	58	79	95	124	147	200	250

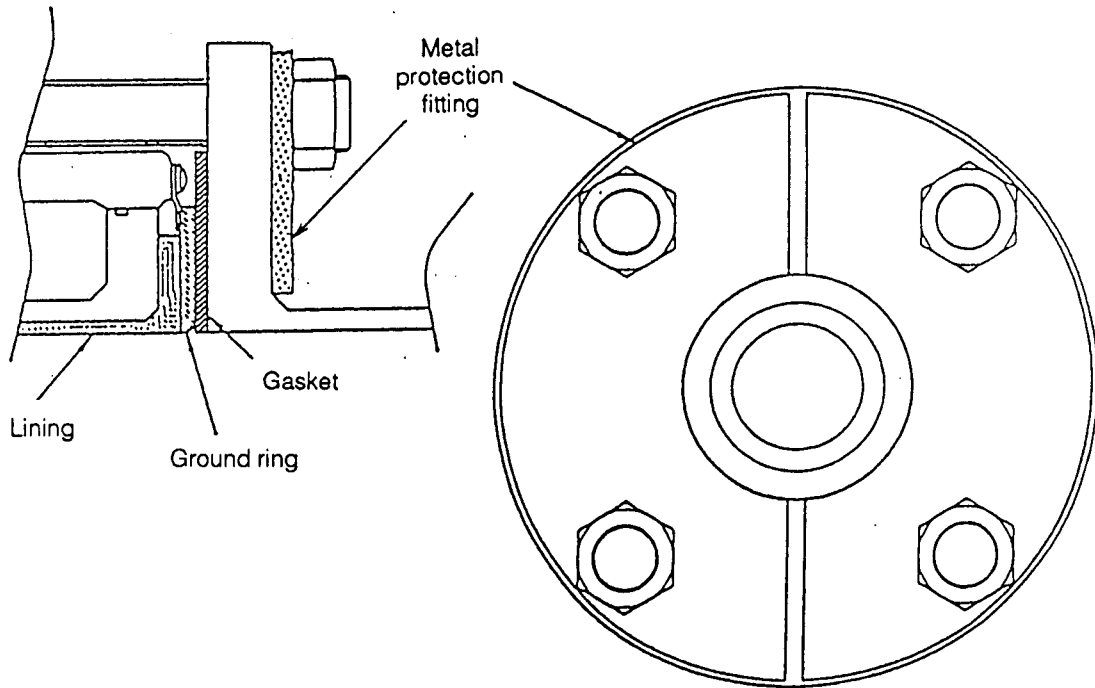

Figure 5-12. Installation onto PVC Piping

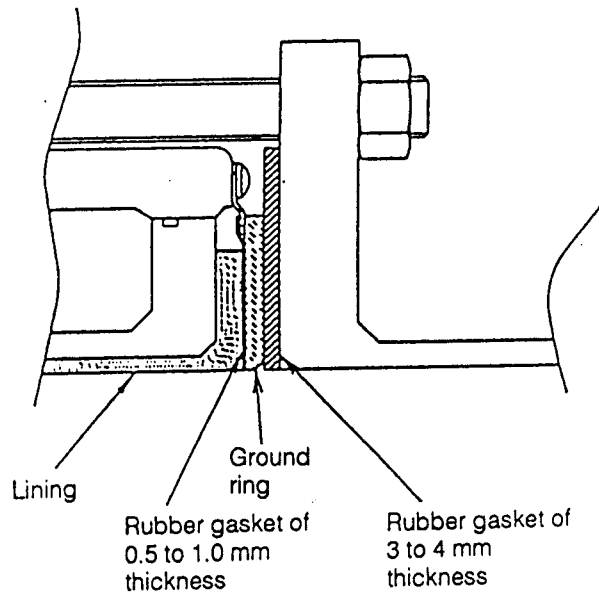

Figure 5-13. Installation onto PVC Pipings with Rubber Gaskets

- 3)-2 A Teflon gasket is supplied attached to the ground ring when the material of the ring is not stainless steel. Don't use any additional gasket for installation. Fluid may leak if an additional gasket is attached onto the supplied Teflon gasket (see Figure 5-14).
- 3)-2-1 When installing a MagneW onto metal pipings, fasten the Teflon gasket as supplied. The fitting of the gasket can change its shape freely according to the fastening torque and no maleffects are supposed on liquid seal.
- 3)-2-2 When installing a MagneW onto PVC pipings, observe the same instruction as described in the above 3)-2-1. The following instructions should also be followed.
- (1) When the PVC pipings may be distorted or damaged, put a metal protection fitting as shown in Figure 5-16 on the face of the PVC flange before fastening.
 - (2) When fastening a rubber gasket with lower torque than specified, two other rubber gaskets of 0.5 to 1.0 mm and 3 to 4 mm thickness respectively with inner and outer diameters as specified in Table 5.1 are necessary. Remove the supplied rubber gasket and fix the gasket of 0.5 to 1.0 mm thickness between the Teflon lining and ground ring. Also fix the gasket of 3 to 4 mm thickness onto the face of the ground ring (see Figure 5-17).

Then fix these two gaskets using the metal fitting and the screw. Install a MagneW using this gasket. (Because a rubber gasket having relatively small gasket factor is inserted between the flange and ground ring and between the ground ring and lining. A complete fluid seal is provided with lower fastening torque.)

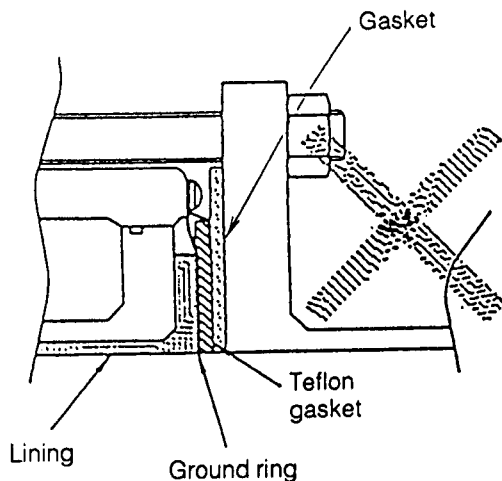

Figure 5-14. Incorrect Installation

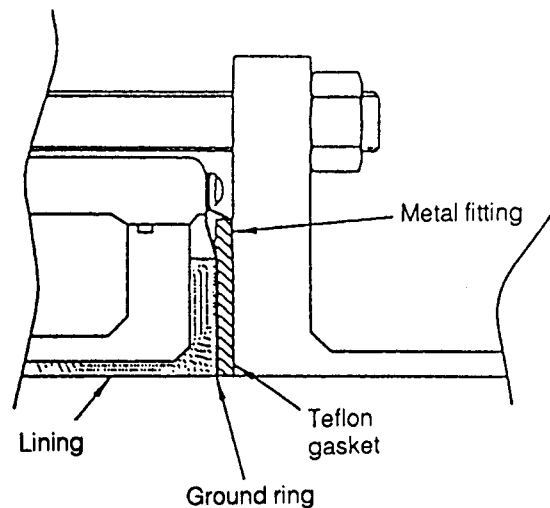

Figure 5-15. Installation onto Metal or PVC Pipings

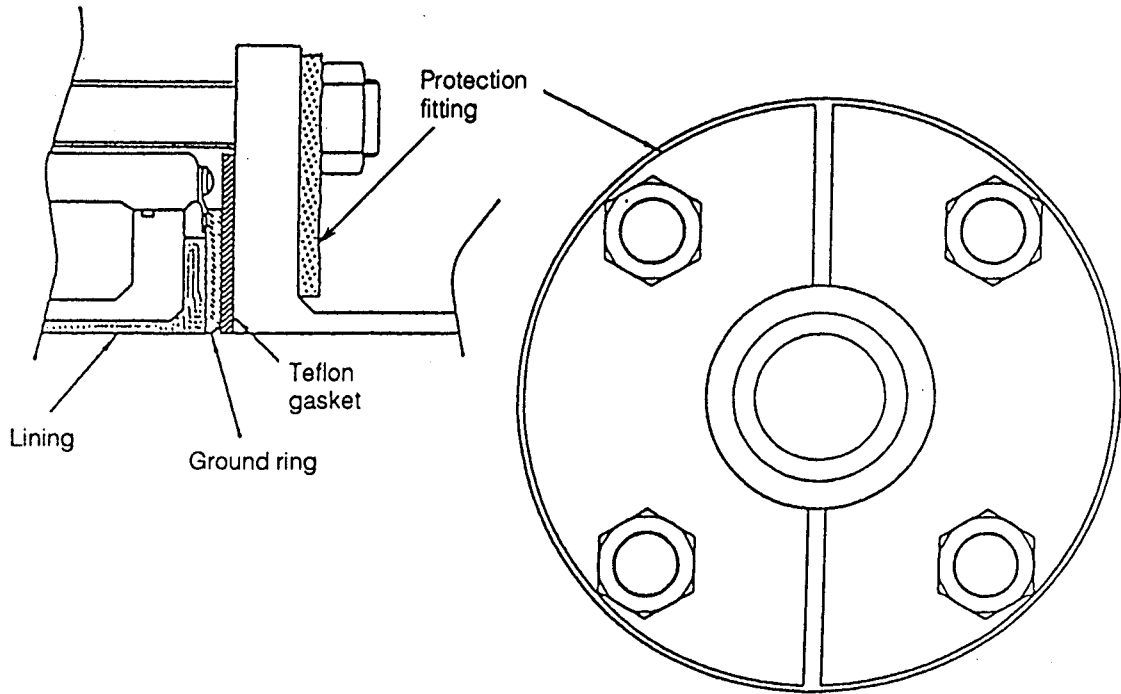

Figure 5-16. Installation onto PVC Piping using Protection Fitting

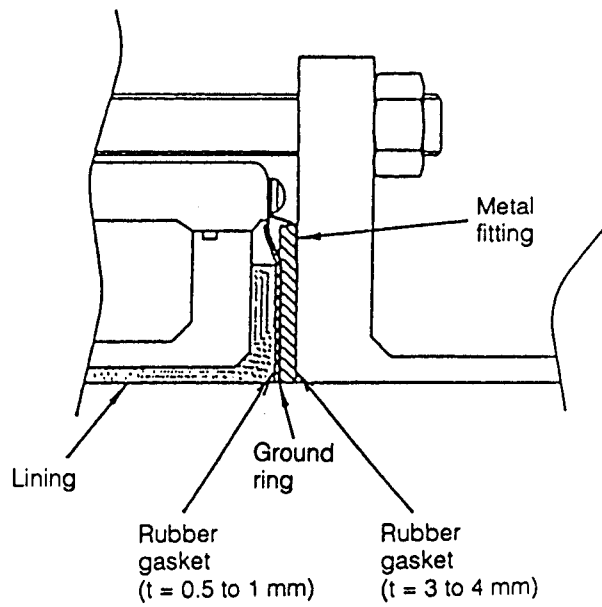

Figure 5-17. Installation onto PVC Piping using Rubber Gasket

3) Installation Method of Flange Type Detector

- a) Make sure that the direction of the arrowhead mark on the detector conform with that of the flow to be measured.
- b) To raise the detector, use wire cables which can safely hoist the detector and connect them to the two eyebolts of the detector.
- c) Finally align the inside surface of the detector to that of the process pipe so that the gasket does not extrude into the flow path.

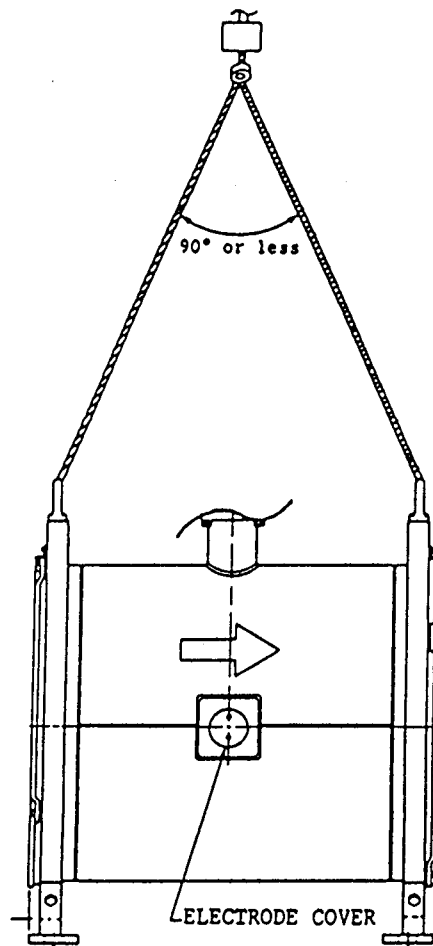

Figure 5-18. Raising the Detector

- d) Tighten evenly the flange bolts referring to the tightening torque shown in the Table 5.3. If liquid leaks, gradually increase the tightening force.

Table 5.3. Tightening Torque

Size (Dia.)	Flange rating	Tightening torque [N·m (kgf·m)]	
		* Teflon	* Chloropren rubber
250A	JIS 10K	51 to 63 (530 to 640)	47 to 57 (480 to 590)
	JIS 20K	81 to 99 (830 to 1020)	
	ANSI 150	69 to 85 (710 to 870)	48 to 58 (480 to 590)
	JIS Water Service Class 2	73 to 89 (740 to 910)	43 to 53 (440 to 530)
	DIN ND10	57 to 69 (580 to 710)	37 to 45 (380 to 460)
300A	JIS 10K	50 to 62 (520 to 630)	47 to 57 (480 to 590)
	JIS 20K	79 to 97 (810 to 980)	
	ANSI 150	56 to 68 (570 to 700)	51 to 63 (520 to 640)
	JIS Water Service Class 2	49 to 59 (500 to 610)	43 to 53 (440 to 540)
	DIN ND10	45 to 55 (460 to 560)	41 to 50 (410 to 500)
350A	JIS 10K	54 to 66 (520 to 630)	50 to 62 (510 to 630)
	ANSI 150	80 to 98 (820 to 1000)	75 to 91 (760 to 930)
	JIS Water Service Class 2	66 to 80 (670 to 820)	60 to 74 (610 to 750)
	DIN ND10	42 to 52 (440 to 540)	40 to 48 (480 to 490)
400A	JIS 10K	72 to 88 (730 to 890)	67 to 81 (680 to 830)
	ANSI 150	80 to 98 (820 to 1000)	75 to 91 (760 to 930)
	JIS Water Service Class 2	69 to 85 (710 to 860)	63 to 77 (640 to 780)
	DIN ND10	72 to 88 (730 to 890)	67 to 81 (680 to 830)
500A	JIS 10K		71 to 87 (730 to 890)
	ANSI 150		106 to 130 (1080 to 1320)
	JIS Water Service Class 2		90 to 110 (920 to 1130)
	DIN ND10		71 to 87 (730 to 890)
600A	JIS 10K		127 to 155 (1290 to 1580)
	ANSI 150		154 to 189 (1580 to 1930)
	JIS Water Service Class 2		89 to 109 (910 to 1120)
	DIN ND10		108 to 132 (1100 to 1340)

* : Gasket

5.5 Notes for Electrical Connections

1) Types of Cables

a) Model KIW Cables Dedicated to MagneW

Model KIW signal cable and exciting current cable are ones dedicated to MagneW flowmeters and MagneW 3000 flowmeters. The signal cable connects the emf output signal of the detector to the converter and the exciting current cable feeds the exciting current to the detector.

For the signal cable, "shield drive"* is necessary or not necessary depending on the detector size, electrical conductivity of measured fluid, and cable length as shown in Figures 5.19 and 5.20.

*: The term "shield drive" means a circuit which is used to compensate for signal distortion (which affects the measuring accuracy) caused by use of a shielded cable for signal transmission. Model KIX Converter is incorporated with the "shield drive" function as a standard feature.

(1) Standard Specifications

Signal cable: 2-core individually-double-shielded
cable (nominal cross section 0.75 mm^2 ,
OD 11.4 mm)

Exciting current cable: 2-core chloroprene-insulated
cable (nominal cross
section 2 mm^2 , OD 11.4 mm)

Weights: Signal cable Approx. 2 kg per
10 meters

Exciting current cable ... Approx. 1.5 kg
per 10 meters

(2) Signal Cable With or Without Shield Drive

Whether a signal cable with or without shield drive should be used depends on the detector size, electrical conductivity of measured fluid and cable length as shown in Figures 5.19 and 5.20, where the clear sections are the areas which call for cables with shield drive and the shaded sections are the areas which do not call for shield drive. (See Table 5.4.)

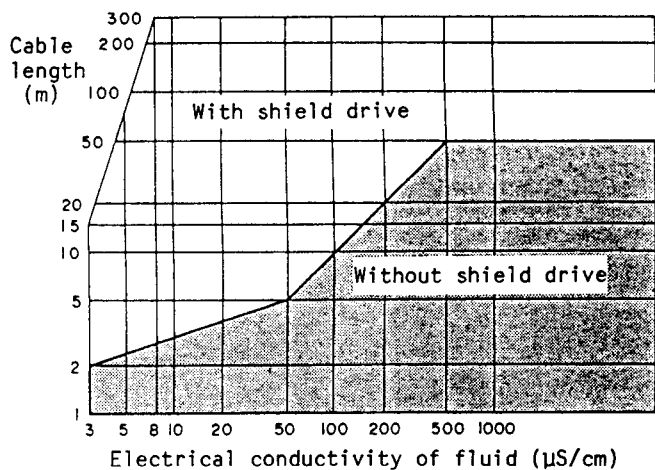

Figure 5-19. Detector Size
2.5 or 5 mm

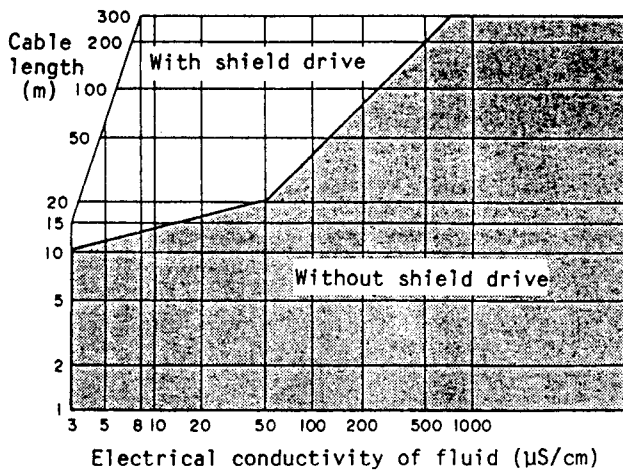

Figure 5-20. Detector Size
10 mm or Larger

(3) Model Number Table of KIW Cables Dedicated to MagneW

Table 5.4. Model Number Construction

Basic Model No.	Selections			Description				
	Cable Length (L)	End Processing						
		Detector Side	Converter Side					
KIW				Dedicated cable for MagneW flowmeter				
	X1			Signal cable				
	1X			Exciting current cable				
	11			Signal/exciting current cable				
	<table border="1" style="display: inline-table; vertical-align: middle;"><tr><td> </td><td> </td><td> </td><td> </td></tr></table>							3 digits. Unit: m
		X		Without cable end terminal processing				
		B		For Model KID□□B				
			X	Without cable end terminal processing				
			A	For Model NNX Note 1				
			B	For Model KIC10B Note 1				
			C	For Model KIC20B/33B Note 1				
			D	For Model KIC20B/33B Note 2				

Note 1: Specify when in the shaded section in Figure 5-19 or 5-20. (Without shield drive)

Note 2: Specify when in the clear section in Figure 5-19 or 5-20. (With shield drive)

(4) Model KIW Cable End Terminal Processing

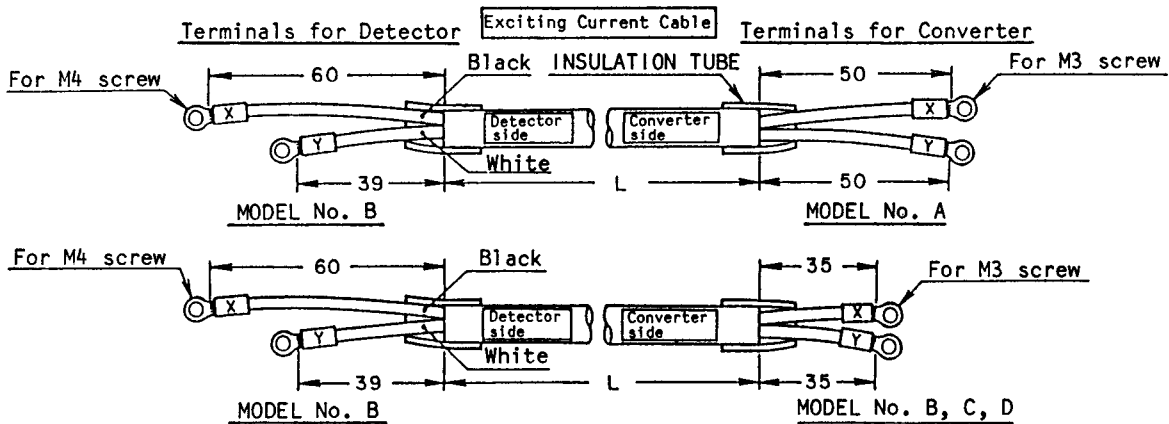
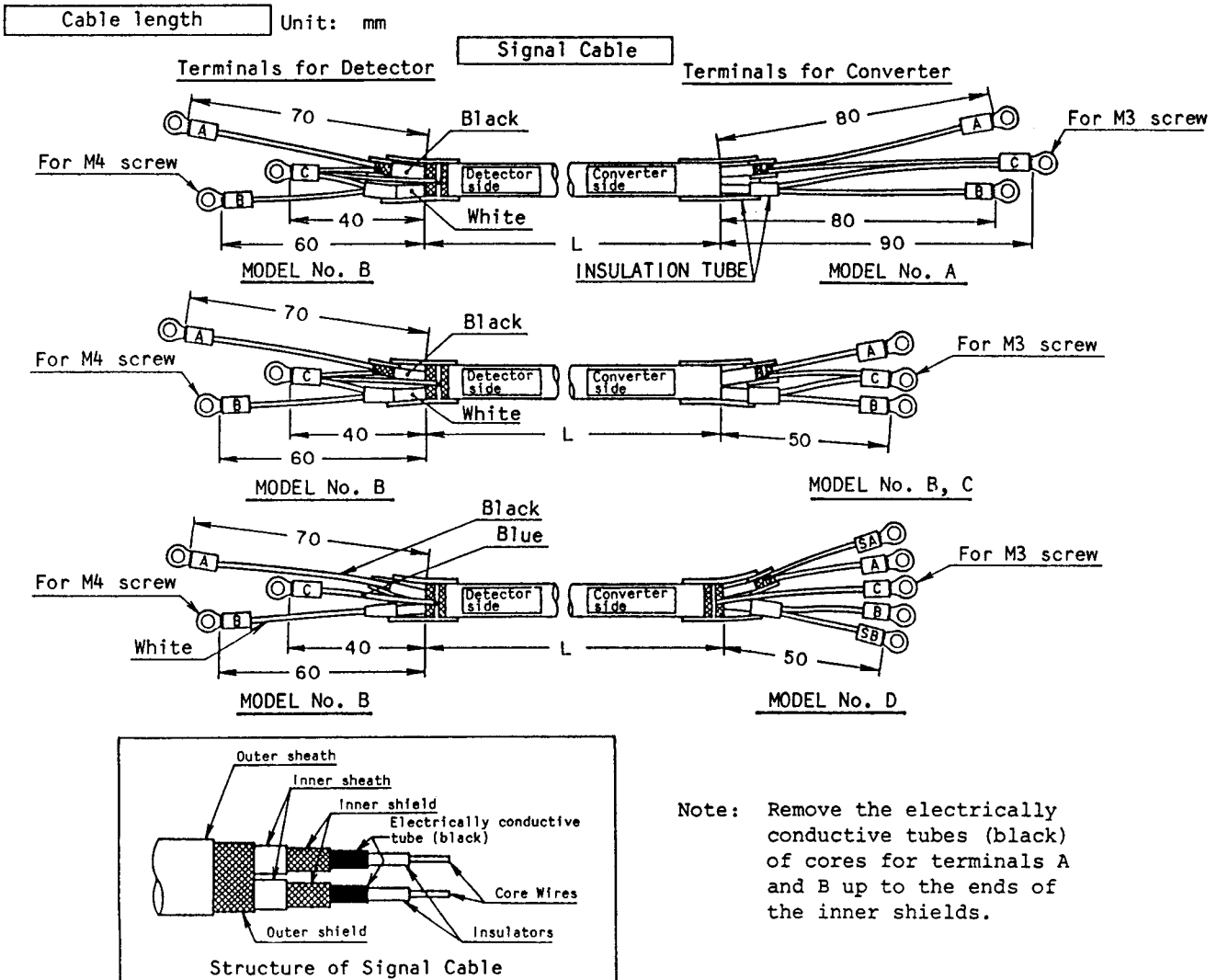

Figure 5-21. Model KIW Cable End Terminal Processing

- (5) When using cables other than Model KIW dedicated to MagneW, use equivalent ones shown in Tale 5.4 in the condition that they meet the requirements of the shaded sections shown in Figure 5-19 and 5-20.

b) Types of Regular Cables Available on Market

Use	Type of cable (example)		Symbol (example)	Normal cross section	Finished OD	
Signal cable	2 cores, shielded	Control cable, polyethylene insulated, polyethylene sheathed, copper braid shielded	CEE-SB 2□ - 2 ^C	2 mm ²	11.4 mm	Capacitance between cores not greater than 200 PF
		Control cable, polyethylene insulated, vinyl sheathed, copper braid shielded	CEV-SB 2□ - 2 ^C			
Exciting current cable	2 cores	Control cable, polyethylene insulated, polyethylene sheathed	CEE 2□ - 2 ^C	2 mm ²	11.4 mm	Core resistance not greater than 6 Ω/300 m
		Control cable, polyethylene insulated, vinyl sheathed	CEV 2□ - 2 ^C			

* The 3-core cable should be used when grounding with the GND terminal of the converter case is unavailable.

2) Laying of Cables

- (a) Do not lay the cables near a motor, a transformer or a large-current cable which may cause induction noise.
- (b) Lay the signal cable in a metallic conduit, a flexible tube or a duct, separately from the exciting current cable.
- (c) When a metallic conduit or a flexible tube is used, it is possible that dew is formed and water is entrapped in the tube. Lay the tube in such manner that no water gets into the instrument.
- (d) Do not employ any junction point for connection of the signal cable or the exciting cable between the detector and the converter. When it is unavoidable to employ a junction point, use the Cable Junction Box (Type NNZ002-X-X) which has been designed specifically for this purpose.

3) Grounding

- (a) At the detector side, be sure to ground the ground ring as per JIS Class 3 Grounding (grounding resistance 100 Ω or less.)
- (b) At the converter side, ground the E of the terminal block or the ground terminal of the case. The E terminal and the ground terminal are mutually connected in the instrument.
- (c) When a lightning arrester is incorporated, ground the grounding terminal as per JIS Class 3 Grounding (grounding resistance 10 Ω or less.)

4) Watertight Glands

- (a) Fully tighten the glands of the cable connection ports to make them watertight.
- (b) Watertight Gland Kit (option)

To use the converter as a watertight unit, use watertight gland kits for the cable inlet/outlet. An exploded view of the watertight gland kit is shown in Figure 5-23. Pass the parts onto the cable in the order shown in Figure 5-22 and then tighten the gland.

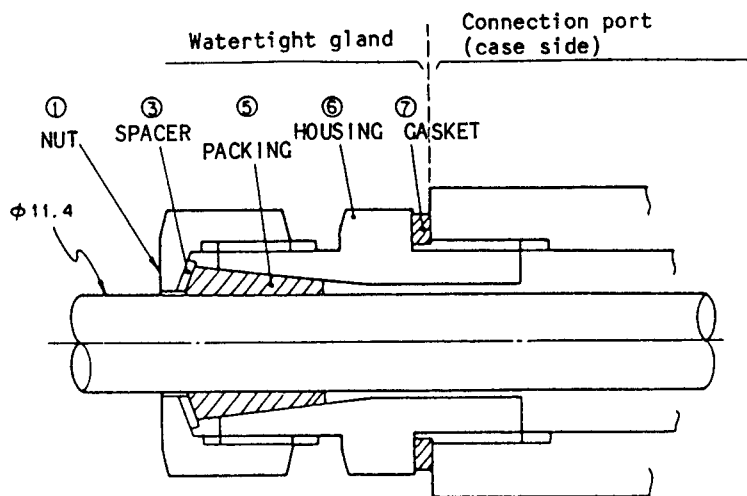

Figure 5-22. Structure of Watertight Gland

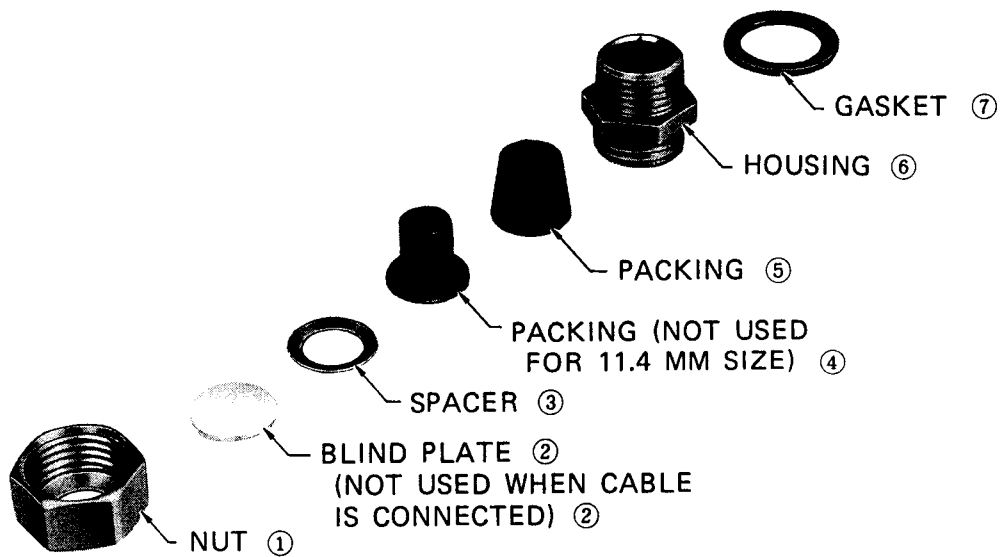
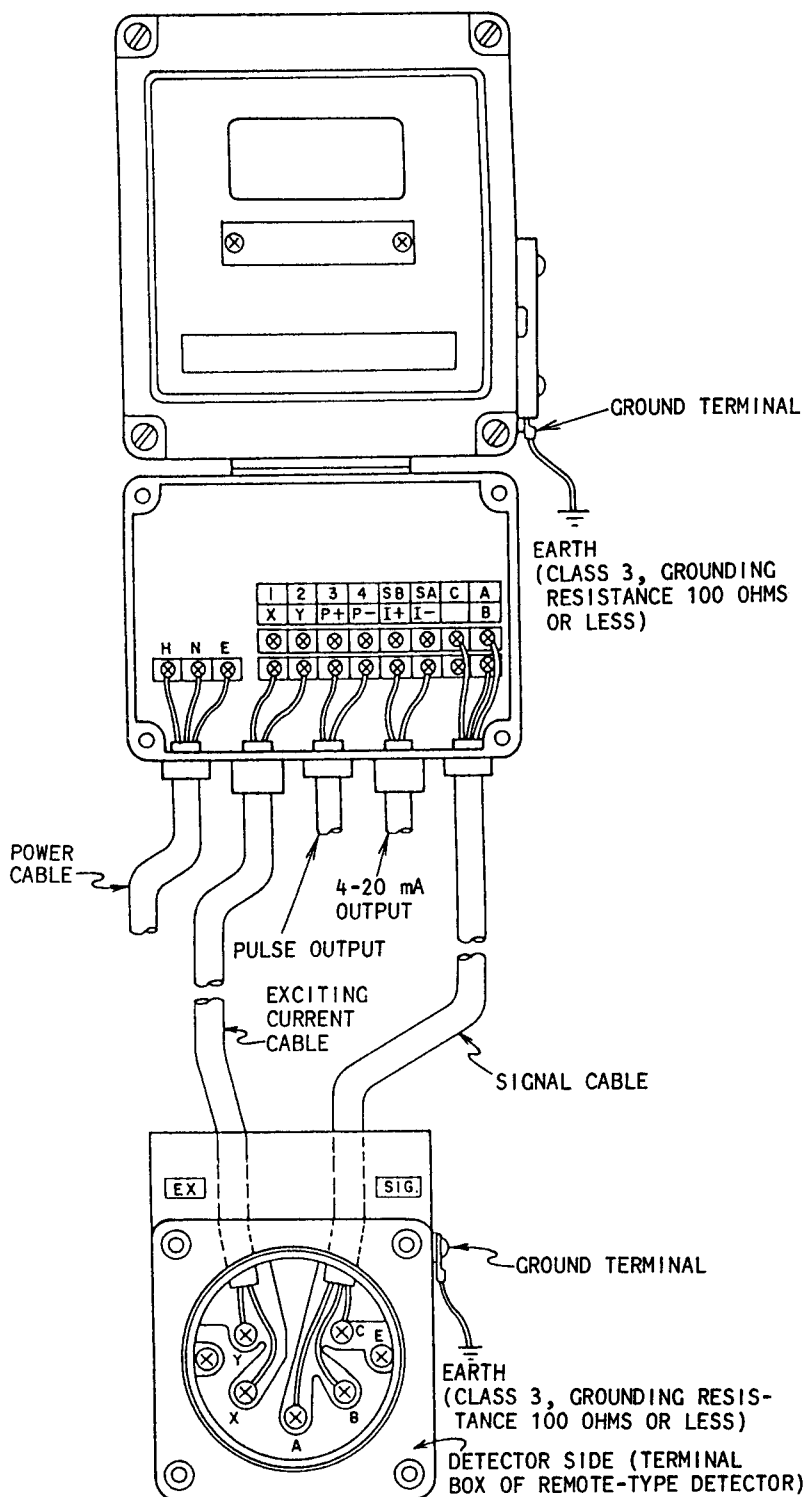

Figure 5-23. Watertight Gland Kit (Optional)

5.6 Cable Connections

1) Cable Connections for Detector and Converter

For connections of cables to the detector and converter, refer to Figure 5-24. Note that connections of signal cables differ depending on the detector size, electrical conductivity of measured fluid and cable length as mentioned in Section 5.4. For connections of signal cables, refer to Figure 5-25.



Converter (KIC20B) Terminals and Connections

Symbol	Connection
A	Flow signal input
B	
C	
SA	
SB	
I+	Current output
I-	
P+	Pulse output
P-	
X	Exciting current output
Y	
1	
2	
3	
4	

H(+)	Power supply
N(-)	
E	Chassis ground

Detector (KID) Terminals and Connections

Symbol	Connection
A	Flow signal output
B	
C	
X	Exciting current input
Y	

Figure 5-24. Cable Connections for Detector and Converter

2) Connections of Signal Cables

(For "shield drive," refer to Figures 5.19 and 5.20.)

a) Without Shield Drive

o Model KIW Dedicated Cables

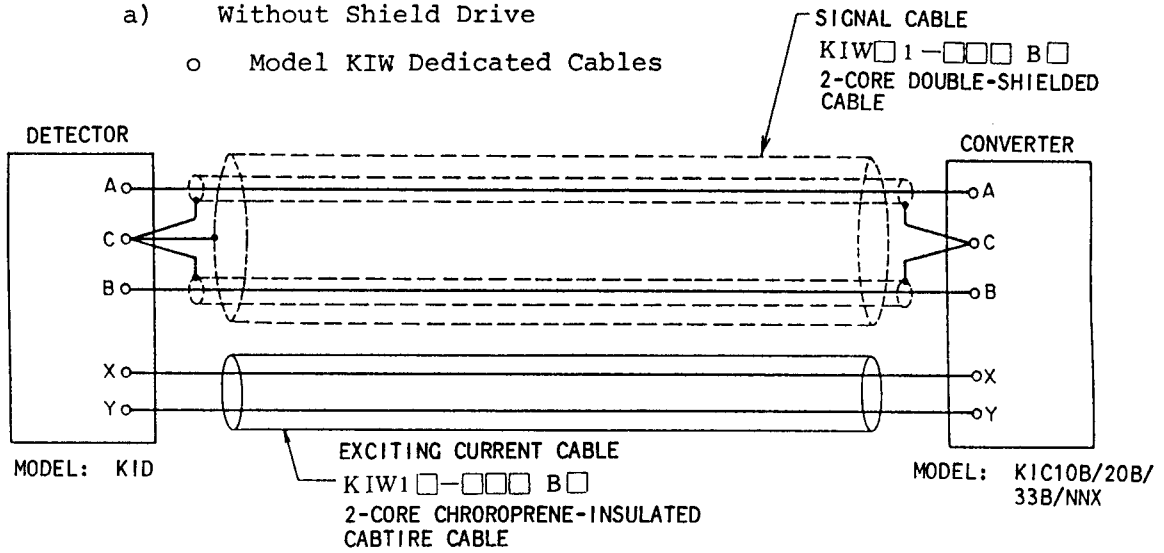

o Regular Cables

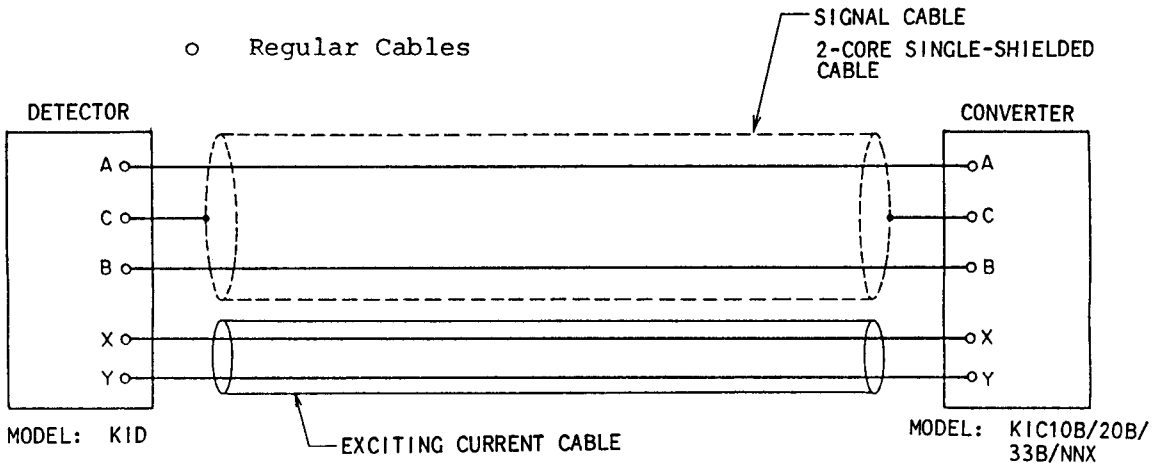

b) With Shield Drive

o Model KIW Dedicated Cables

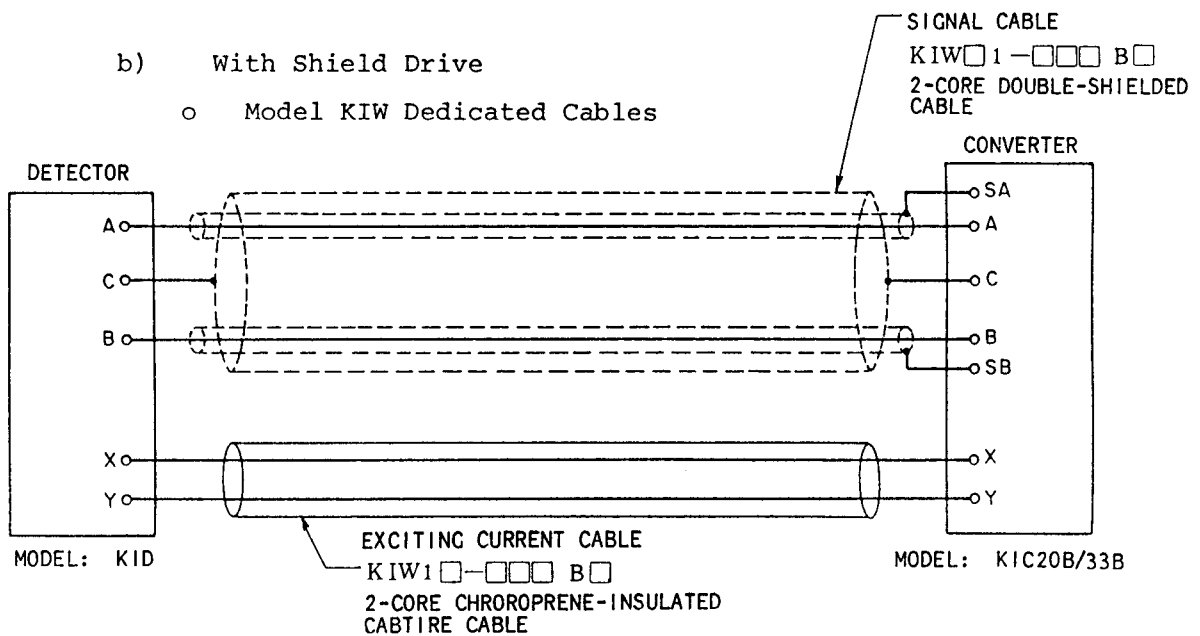

Figure 5-25. Connections of Signal Cables

6. OPERATION METHOD

6.1 Inspection

Inspect the items shown in Table 6.1

Table 6.1

Section	Inspection item
1. Overall flowmeter	1) Check that the detector and converter are correctly installed. 2) Check that the cables are correctly connected between detector and converter.
2. Detector flange section	1) Check that the gaskets are properly set and not shifted. 2) Check that the clamp bands are tightened and there is no leak. 3) Check that liquid is grounded.
3. Detector terminal section	1) Check that the terminal screws are tightened. 2) Check that the cables (cores) are not broken or shorted. 3) Check that the cable inlet/outlet glands are tightened. 4) Check that the terminal covers are securely installed.
4. Detector case	1) Check that the case is grounded.
5. Converter terminal section	Check the items the same as those of 3.
6. Converter case	Check that the case is grounded.

6.2 Preparation for Operation

- 1) Procedure before turning on power
 - (1) Fill the detector with stationary liquid.
 - (2) Turn on power of the converter. (Allow approximately 10 minutes of stabilization time after turning on power.)

7. MAINTENANCE

7.1 General

Normally, the detector is not needed to be inspected routinely. However, if the measured liquid involves particles or stains, such substance may be collected on the electrodes and the indication may become inaccurate or unstable. If this is the case, the detector inside (especially the electrodes) should be cleaned periodically.

7.2 Electrode Cleaning

- 1) When removing the electrodes alone (Applicable to splashproof type only) (See Figure 7-1)

The electrodes can be removed for cleaning without removing the detector from the process line. To do this, proceed as follows:

- a) Turn off power of the flowmeter.
- b) Drain out liquid from inside of the detector.
- c) Remove the electrode covers and disconnect the electrode leadwires. (See Figure 7.1.) Remove the springs and other retaining parts of the electrodes using the electrode remover* and then take out the electrodes.

* Optional
(Parts No. 80356200-001)

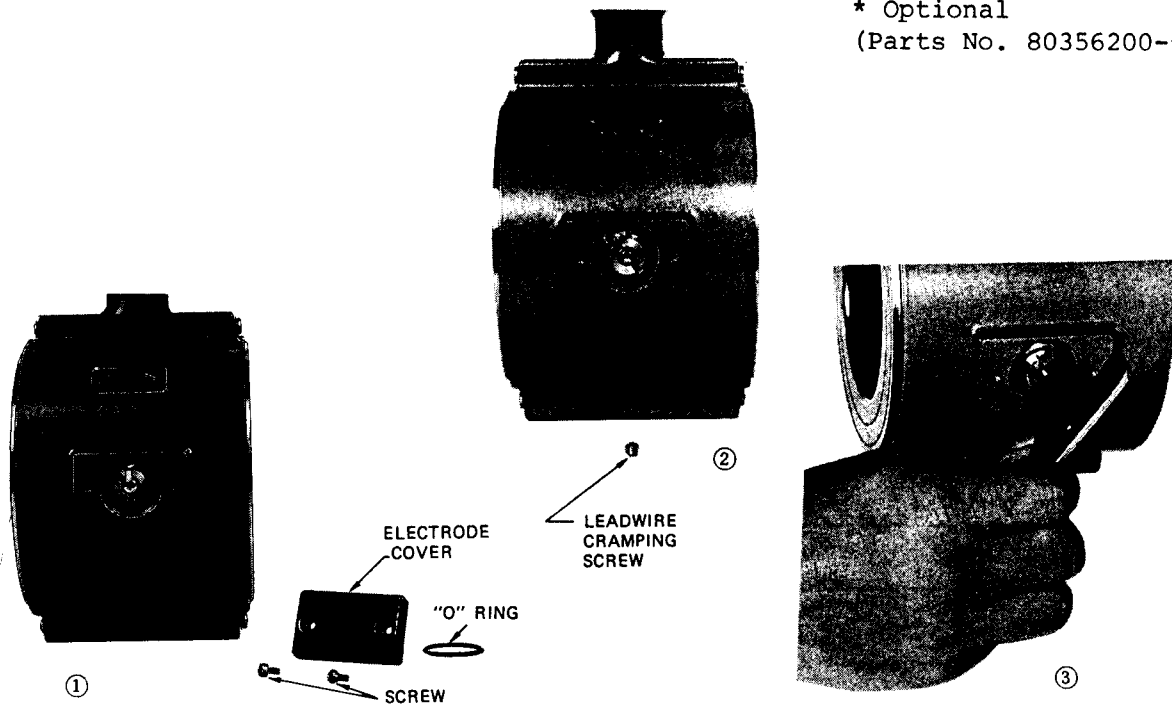

Figure 7-1. Removing the Electrodes

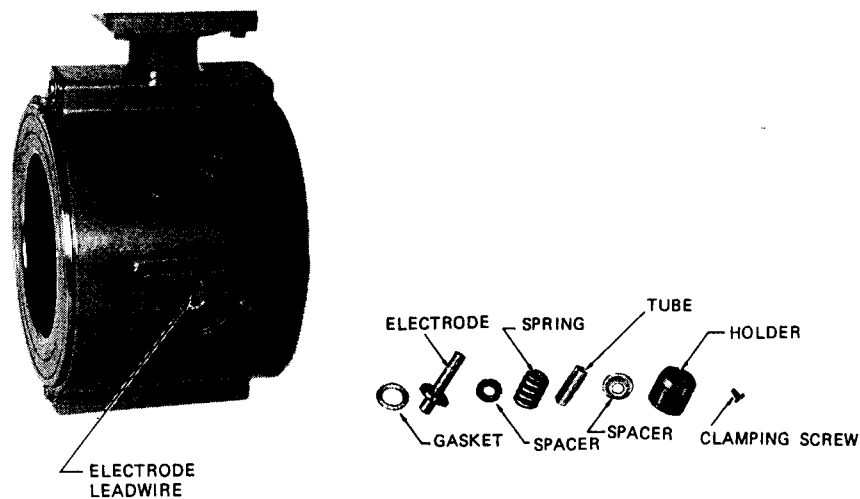

Figure 7-2. Removing the Electrodes

- d) Clean the electrode surfaces using thinner, alcohol or other detergent.
- e) Replace the electrodes into the detector.

Note: Before inserting the electrodes into the detector, thoroughly wipe off liquid which may be spilt at the electrode sections. Be sure to correctly install the gaskets. (It is most recommendable to use fresh gaskets.) Be sure to fully tighten the screws. If they are loose, liquid may leak from the electrode sections.

- f) Fill the detector with stationary liquid and check that there is no leak from the electrode sections. Connect the electrode leadwires and replace the electrode covers for secure shielding.
 - g) Turn on power of the flowmeter.
 - h) After allowing a stabilization time of approximately 10 minutes, make zero adjustment.
- 2) When removing the detector from the process line

When removing the detector from the process line for cleaning, excise care not to damage the lining. Note that the detector may become unusable if its lining is damaged.

8. TABLE OF STANDARD ACCESSORIES

	<u>Q'ty</u>
Centering jigs	4

Document Number : OM2-5660-0110
Document Name : MagneW3000 Electromagnetic
Flowmeter Detectors
Model: KID10B/11B/12B(Remote Type)

Date : July, 1998 (Rev.5) (Y)
Issued / Edited by : Yamatake Corporation
