

The Multivariable Air Flow Meter AIRcube

Model MVC10A / MVC10F

OVERVIEW

The Multivariable Mass Flow Meter AIRcube, a compact flow meter has all function necessary to measure nitrogen (N₂) gas and air. The model MVC10A/MVC10F can accurately measure differential pressure, static pressure, and process temperature to dynamically calculate fully compensated mass flow of factory compressed air, and N₂ gas in food and beverage for anti-oxidation.

The model MVC10A/MVC10F is very useful to save energy with indicating cost of air and N₂ and leak-check function.

FEATURES

High accuracy

A state-of-the-art Dual Sensor realizes accurate measurement of mass flow rate by measuring Differential Pressure (DP), Gauge Pressure (GP), and Temperature (T) for the density compensation.

Full display function

Model MVC10A/MVC10F can display volume flow and mass flow, and velocity or pressure.

Stable measurement

- The streamline shaped flow tube (etube) can minimize the scaling and the clogging.
- Output is with excellent reproducibility due to smooth and stable streamline by elliptic tube. The rangeability of flow rate is as wide as 1 to 30, so measurement is possible down to almost zero flow rate.
- Even with a short upstream length, it provides high accuracy.

Unique functions

- **Cost indication**
To save energy management, it has cost indication.
- **Auto ranging function**
The measuring range can automatically set with memorizing maximum flow even if the actual flow rate is unknown.
- **Leak check function**
Measuring pressure in pipe with built-in pressure sensor, indicate leak rate necessary to economize energy.

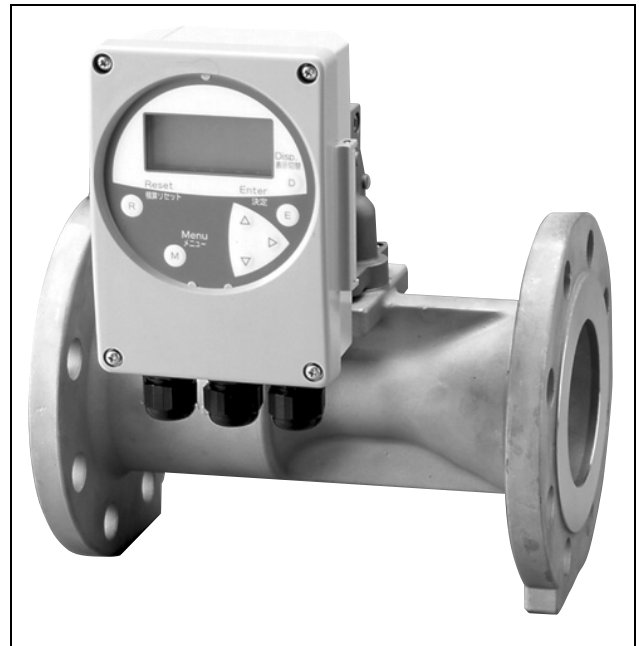

APPLICATIONS

- Measuring air flow each manufacturing process
- Promoting economized energy to grasp actual consumption of air each factory and shop
- Observing capacity of equipment
- Measuring flow of N₂ gas

PRINCIPLE

The AIRcube is a differential pressure flow meter based on the Bernoulli theorem.

Flow (Q) is calculated by the following equation.

$$Q = A\sqrt{(\Delta P)/\rho}$$

$$\rho = \frac{(PI + 101.325)}{101.325} \times \frac{273.15}{(273.15 + TI)}$$

ρ : Actual differential pressure

ΔP : Density of air

PI : Primary pressure

TI : Temperature

A : Flow coefficient

Detector specifications

Size: 50, 65, 80, 100, 150 mm

Wetted material: SCS13

Measuring fluid: Compressed air, N₂

Fluid pressure

0.05 to 0.98 MPaG (Remote type: 0.05 to 0.9 MPaG)

Ambient temperature limit: -15 to 50°C

Fluid temperature limit: -15 to 70°C

Measuring flow range

Pressure [MPaG]	Maximum flow value [Nm ³ /h]				
	Size				
	50 mm	65 mm	80 mm	100 mm	150 mm
0.98	1400	2300	3200	5500	12000
0.9	1300	2200	3100	5000	11500
0.8	1200	2100	2900	5000	10500
0.7	1200	2000	2700	4500	10000
0.6	1100	1800	2500	4000	9000
0.5	1000	1700	2300	4000	8500
0.4	900	1500	2000	3500	7500
0.3	750	1300	1700	3000	6500
0.2	550	950	1300	2300	4500
0.1	350	650	900	1500	3000
0.05	250	450	650	1000	2000

Pressure [MPaG]	Minimum flow value [Nm ³ /h]				
	Size				
	50 mm	65 mm	80 mm	100 mm	150 mm
0.98	40	65	90	150	330
0.9	40	65	85	150	310
0.8	35	60	80	140	300
0.7	35	60	75	130	280
0.6	30	55	70	120	260
0.5	30	50	65	110	240
0.4	25	45	60	100	220
0.3	25	40	55	90	200
0.2	20	35	45	80	170
0.1	20	30	40	65	140
0.05	15	25	35	55	120

Performance

Reference accuracy

For the flow one tenth of maximum flow limit or more:
±3% of reading

For the flow less than maximum flow limit of one tenth:
±(Q_{at1/10}×3)/Q% of reading

Q_{at1/10}: 1/10 flow of maximum flow

Q: measuring flow

Temperature effect

±0.05%/°C of reading

Permanent pressure loss

More than 0.3 MPa of static pressure

$$P.Loss = 50 \times \left(\frac{Q}{Q_{max}}\right)^2$$

Less than 0.3 MPa of static pressure

$$P.Loss = 0.5 \times (238 \times SP + 23) \times \left(\frac{Q}{Q_{max}}\right)^2$$

Symbol	Unit	Explain
P.Loss	[kPa]	Pressure loss of flow
Q	[Nm ³ /h]	Flow value
Qmax	[Nm ³ /h]	Maximum flow value
SP	[kPa G]	Process pressure (static pressure)

Install position: Horizontal or vertical

Mounting: Integral type or remote type

Converter specifications

Material

Wetted material: SUS316
 Detector: SCS13
 Detector cover: SCS13
 Case: Aluminum alloy
 Cover: Polycarbonate
 Bolts and nuts materials: SUS304
 Tube for remote type: Nylon (maximum 5 m)*
 Tube fitting: Brass + POM

Note) *: One tube of 10 m is attached.

Manufacturer: PISCO Co. Ltd.

Tube: NA0640-20R (the outside diameter: 6 mm, the inside diameter: 4 mm)

Converter case fitting (only Aluminum case):

Based acrylic paint

Power supply: 90 to 250V AC

Power: 5 W (maximum)

Output signal

Analog output: 4 to 20 mA DC

Pulse output: Open collector output

Pulse width: 1 or 10 ms (Automatically selected according to the pulse weight.)

Pulse frequency: 0.005 to 500 Hz

Supply voltage: 10 to 30V DC

Max current: 50 mA

Display

Main display: 8 digits

Sub display: 16 digit, 2 lines

Display contents: Simultaneously display % flow rate, flow rate, totalized flow, flow velocity, pressure, cost, totalized cost, various set up parameters

Main/Sub display selection:

Max. 2 contents are available in display contents

Display unit: Volume flow: m³
 Mass flow: kg, t
 Cost: ¥, \$
 Velocity: m/s
 Pressure: MPa
 Time: d, h, min, s

Damping: Adjustable between 0 and 128 seconds

Low flow cutoff

Adjustable between 0 and 20% of setting range

Power failure

An EEPROM retains data record of totalized flow and various set up parameters.

Installation specifications

Pressure limits: 0.05 to 0.98 MPaG (remote type: 0.05 to 0.9 MPaG)

Ambient temperature limit: -15 to 50°C

Ambient humidity limit: 5 to 95% RH

Electrical conduit: G1/2 (3 ports)

Installation: Detector/Converter integral type, Wall mounting, 2-inch pipe mounting

Grounding:

The most effective grounding method is direct connection to earth ground with minimal impedance. Grounding resistance lower than 100 Ω

Weight: 9 kg (50 mm), 11 kg (65 mm), 13 kg (80 mm), 18.5 kg (100 mm), 39.5 kg (150 mm)

Straight pipe lengths: The minimum straight pipe length

Upstream side L ₁						Down-stream side L ₂
						All the joints shown to the left
0.5	1.5	4.0	2.5	1.5	2.5	

Function

Totalized function

Counting by one count according to the display flow unit setting.

Auto ranging function

After turning on the power or the peak value is reset, the AIRcube automatically sets the measuring range at 80% of the maximum flow rate.

Leak check function

Calculate the leak rate by measuring line pressure with a built in pressure sensor.

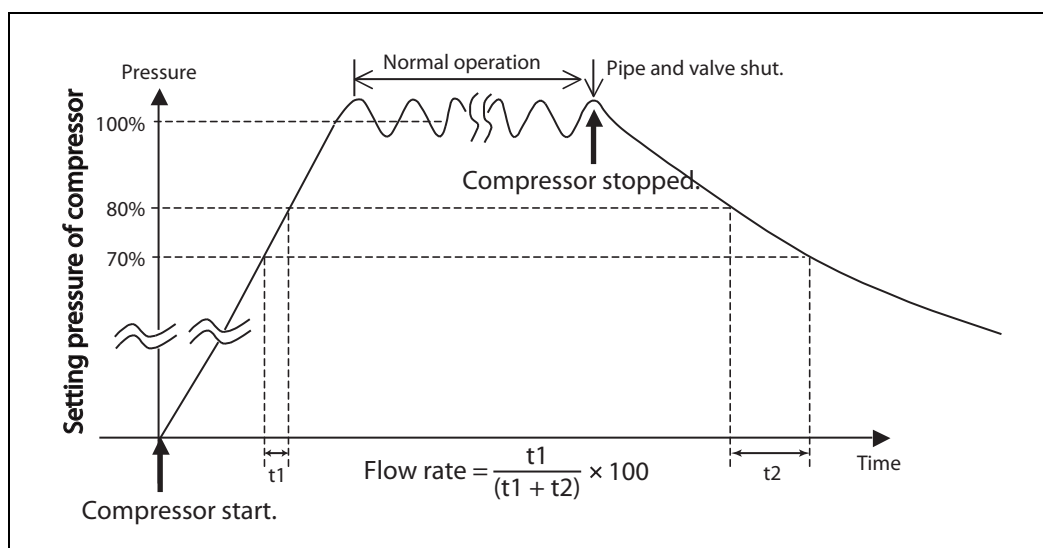

MODEL SELECTIONS

The Multivariable Air Flow Meter AIRcube

Basic model no.		Selections						Options	
Integral type	MVC10A	-						-	
Remote type	MVC10F	-						-	
Line size	50 mm		050						
	65 mm		065						
	80 mm		080						
	100 mm		100						
	150 mm		150						
Customer code	Standard		STD						
Power supply	Standard (90 to 250V AC)			A					
Process connection	Flange JIS 10K				J1				
Installation / flow direction	Horizontal piping / left to right					HL			
	Horizontal piping / right to left					HR			
	Vertical piping / upward to downward					VH			
	Vertical piping / downward to upward					VL			
Face to face dimension	Standard					S			
Calibration	Standard (AIR)						1		
	Standard (N ₂)						2		
Finish paint	Std. corrosion-proof finish							X	
Options	No option								X
	Test report								A
	Set the tag number								C

Electrical wiring

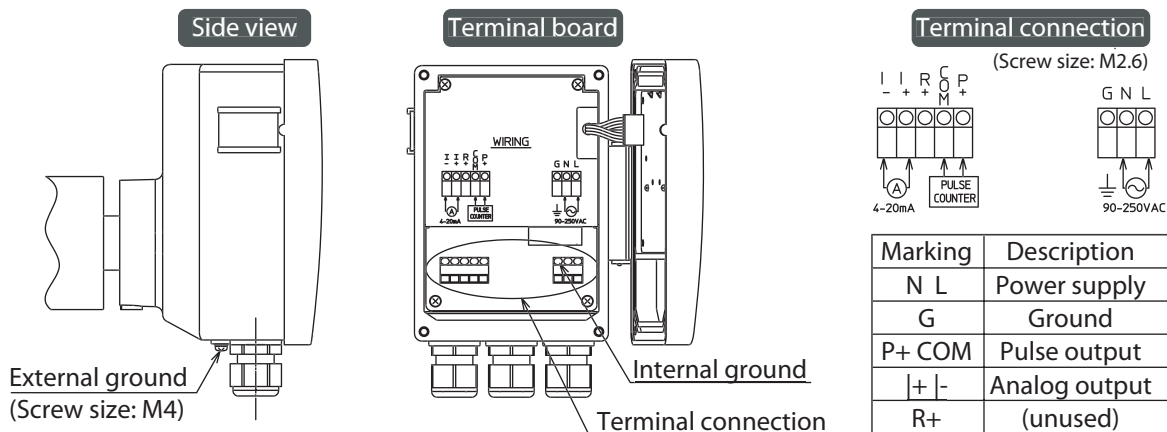

DIMENSIONS

Model MVC10A horizontal installation

[Unit: mm]

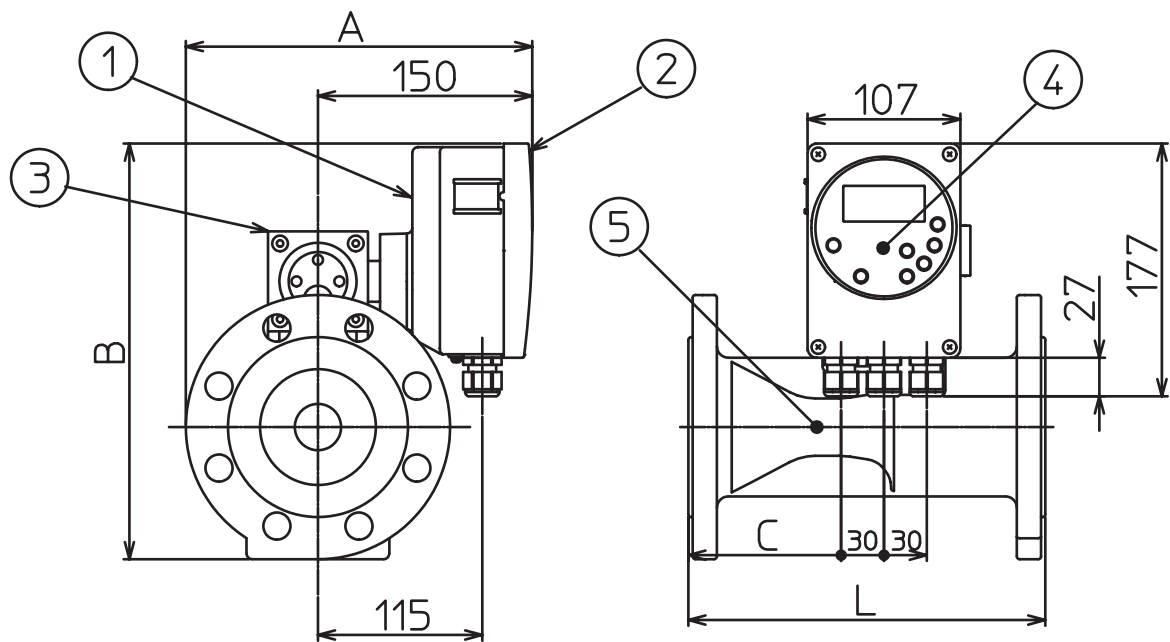

Model MVC10A vertical installation

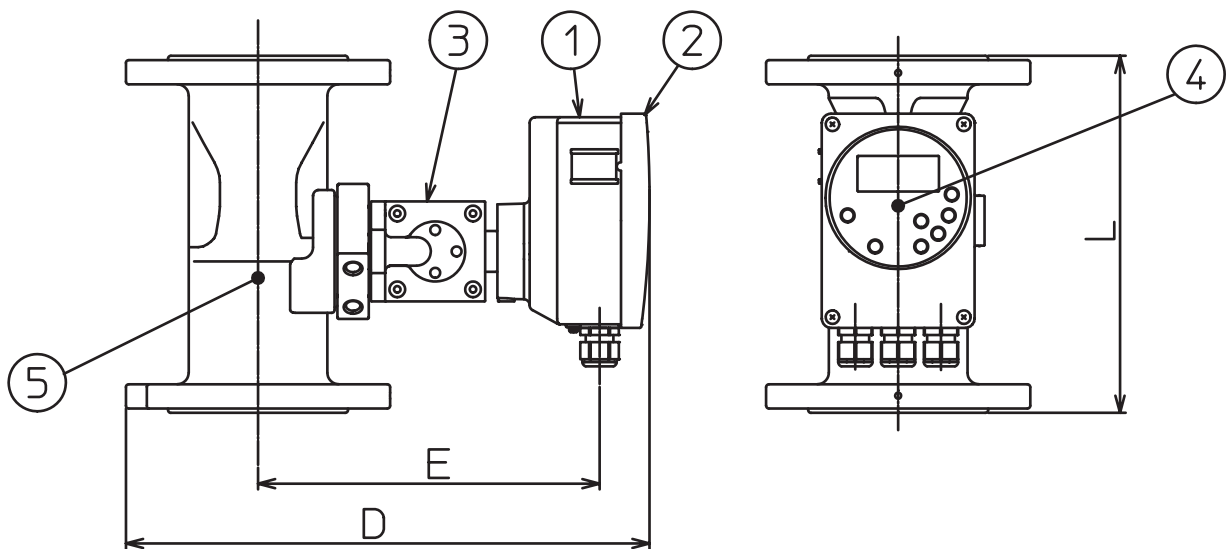

Dimensions and weight

Flange size	50 mm	65 mm	80 mm	100 mm	150 mm
A	228	238	243	255	290
B	259	285	290	318	385
C	70	104	108	154	205
D	335	350	365	395	460
E	222	227	238	254	284
L	200	250	250	300	350
Flange	According to JIS standards				
Weight	9 kg	11 kg	13 kg	18.5 kg	39.5 kg

Materials

Key no.	Part name	Material
1	Case	ADC 12
2	Case lid	Polycarbonate
3	Cover flange	SCS 13
4	Screen sheet	Polyethylene
5	Flow tube	SCS 13

Model MVC10F

[Unit: mm]

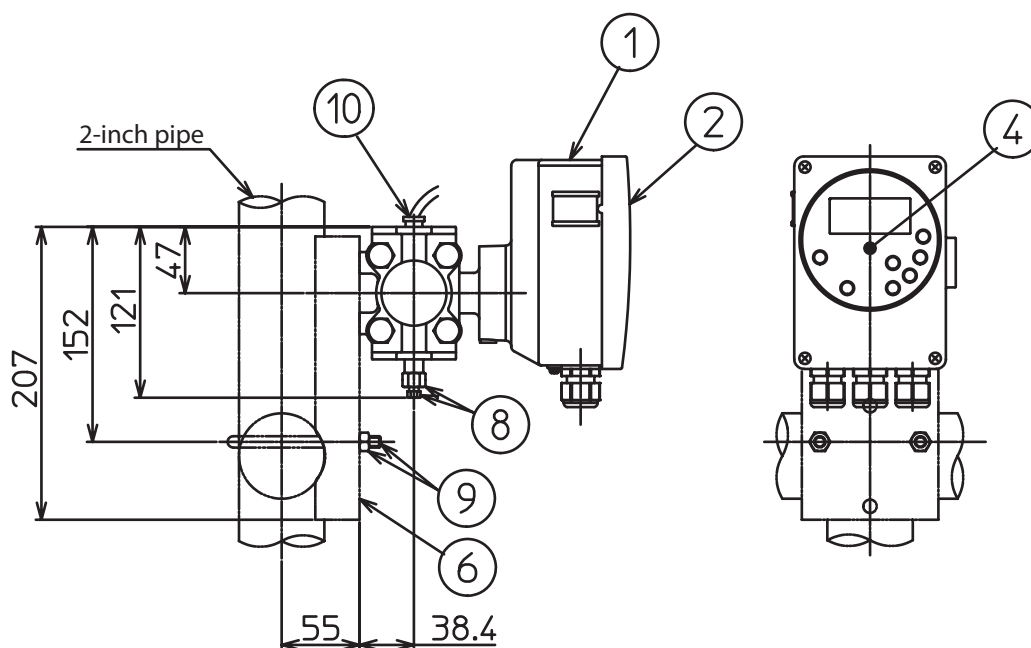
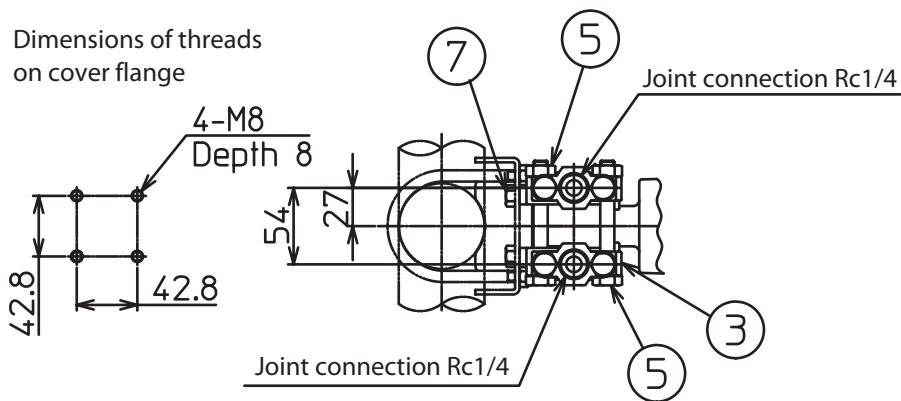

Materials

Key no.	Part name	Material
1	Case	ADC 12
2	Case lid	Polycarbonate
3	Cover flange	SCS 13
4	Screen sheet	Polyethylene
5	Bolt / Nut	SUS304
6	Bracket	SPCC
7	Bolt	SUS304
8	Vent / Drain plug	SUS316
9	U bolt / Nut	SUS304
10	Tube / Tube fitting	Nylon / Brass + POM

Installation Precautions

Obey following precautions to prevent accidents, and for product to function to its best ability. Be sure to read user's manual before use of product.

Cautions During and After Installation

CAUTION

- For vertical installation, be sure to adjust zero output at working pressure.

CAUTION

- Do not step on product. May break and cause injuries.
- Do not tap window with hard tools. Glass may break and cause injuries.
- During installation, always hold product with sufficient footing and use safety shoes. Product is heavy in weight and may cause injuries when dropped.

WARNING

- Be sure that no pressure remains within piping when removing product from piping.
- Be careful of burns when process temperature is high. Product temperature will rise with process and remain so for some time.

Cautions Concerning Ambient Conditions

- Use product where there is no sudden change in ambient temperature. May cause output errors. Gradual changes should also be avoided as much as possible.
- If possible, keep product out of direct sunlight. Plastic material of case lid may be damaged.
- Keep product out of direct rain and wind.
- Do not use product in corrosive gas surroundings.
- Avoid pipe vibrations as much as possible. (Vibrations to be below 5m/S²)
- Cut off power supply to product when welding nearby piping. May cause damages according to method of grounding. Welding instruments should be grounded directly.

Cautions Concerning Electrical Wiring

CAUTION

- Carefully confirm wiring terminals and connect accordingly. Incorrect wiring may cause irreparable damages to product.
- Be sure to supply correct power according to product's specification. Incorrect power supply may cause irreparable damages to product.

WARNING

- When wiring, be sure to turn off power before opening lid. May cause electric shock.
- Do not conduct wiring when lines are alive. May cause electric shock.

Yamatake Corporation

Totate international Building
2-12-19 Shibuya
Shibuya-ku, Tokyo 150-8316
Japan

Tel : 81-3-3486-2310
Fax : 81-3-3486-2593

YAMATAKE

Savemation

Saving through Automation