

MagneW 3000 PLUS Smart Electromagnetic Flowmeter Detector for Sanitary use Model MGS28U

OVERVIEW

The MagneW3000 PLUS Smart Electromagnetic Flowmeter for Sanitary use is a high-performance and highly-reliable flowmeter based on Yamatake's field-proven flow measurement technologies.

The MagneW3000 PLUS sanitary model features internal electrodes which prevent the build-up of flow media residue in the detector. The Tri-clamp or IDF clamp connection brings about easy maintenance, easy to remove the detector for servicing.



Integral type
Size 15 to 125 mm (1/2 to 5 inches)

FEATURES

- A clamp connection makes it easier to install or remove from piping.
- The lining material PFA is in conformity with FDA (Food and Drug Association).
- There is no moving part, or obstructions to flow inside the flowmeter. It is suitable for IP cleaning.
- Internal electrodes eliminate the build-up of flow media residue.
- Nominal size from 15 to 125 mm (1/2 to 5 inches) ensures broader applications.

GASKET SELSCTION

- EPDM or silicone rubber is selectable for the gasket material.

EPDM

Used for CIP below 120 degree C.

Better corrosion-resistant material.

Silicone rubber

Used for high temperature steam cleaning up to 150 degree C.

APPLICATIONS

Applicable to a wide range of applications in various foods and other industries.

- Potable water
- Mineral water
- Soy sauce
- Jam
- Beer
- Juices
- Milk
- Yogurt
- Tea
- Industrial water
- Waste water

FUNCTIONAL SPECIFICATIONS

Type of protection

JIS C 0920 watertight model
NEMA ICS6-180 TYPE4X
IEC PUBL 529 IP67

Size

15, 25, 40, 50, 80, 100, 125 mm
(1/2, 1, 1½, 2, 3, 4, 5 inches)

Temperature range of process fluid

Diameter	Temperature of the liquid to be measured	
	Integral model	Remote model
15 to 125 mm (1/2 to 5 inches)	-40 to +120°C (-40 to +248°F)	-40 to +160°C (-40 to +320°F)

Pressure range of process fluid

-0.098 to +0.98 MPa (-14.2 to 142 psi)

Ambient temperature limits

-25 to +60°C (-13 to 140°F) (integral model)
-30 to +80°C (-22 to 176°F) (remote model)

Ambient humidity limits

5 to 100% RH

Measurable electrical conductivity

Combined with model MGG14C converter 3 µS/cm or more

Accuracy

The standard accuracy is +/- 0.5% of rate.
Also available is an optional high accuracy calibration rated at +/- 0.35% of rate (sizes of 40mm to 125mm (1½ to 5 inches), combined with MGG14C).

Measurement flow range

Refer to the minimum / maximum set ranges shown in the table below.

Diameter		Minimum flow velocity range is 0 to 0.1 m/s (0 to 0.33 ft/s)		Maximum flow velocity range is 0 to 10 m/s (0 to 32.8 ft/s)		Conversion factor K
		Minimum range		Maximum range		
mm	inches	m ³ /h	GPM	m ³ /h	GPM	
15	1/2	0 to 0.06362	0 to 0.2802	0 to 6.361	0 to 28.01	1.572
25	1	0 to 0.1768	0 to 0.7782	0 to 17.67	0 to 77.81	0.5659
40	1½	0 to 0.4524	0 to 1.993	0 to 45.23	0 to 199.2	0.2210
50	2	0 to 0.7069	0 to 3.113	0 to 70.68	0 to 311.2	0.1415
80	3	0 to 1.810	0 to 7.969	0 to 180.9	0 to 796.8	0.05526
100	4	0 to 2.828	0 to 12.46	0 to 282.7	0 to 1245	0.03537
125	5	0 to 4.418	0 to 19.46	0 to 441.7	0 to 1945	0.02264

Optional specifications

Test report

Calibration certificate, withstand voltage test, insulation resistant, hydrostatic pressure test, physical inspection are included.

Traceability certificate

The following three documents are included.

- Traceability System Chart
- Traceability Certificate
- Test Report

Attaching the tag number to the terminal box

Stamp the tag with the specified number and attach to the terminal box. The maximum number of characters of the tag number is 8.

Attaching the tag number to the neck section

Stamp the tag with the specified number and attach to the neck section of the detector with stainless wire. The maximum number of characters of the tag number is 16.

Attaching the two spare gaskets

When changing the gaskets, use these gaskets for IDF clamp or Tri-clamp.

For additional specifications, please contact your Yamatake representative.

PERFORMANCE SPECIFICATION

Accuracy

(in combination with the model MGG14C converter)

Vs = Velocity of setting range

Vs (m/s)	Velocity during measurement $\geq V_s \times 20\%$	
	Standard Accuracy (Calibration Code A)	*)High Accuracy (Calibration Code U)
$1.0 \leq V_s \leq 10$	$\pm 0.5\%$ of rate	$\pm 0.35\%$ of rate
$0.1 \leq V_s \leq 1.0$	$\pm(0.1/V_s+0.4)\%$ of rate	$\pm(0.1/V_s+0.25)\%$ of rate

Vs (m/s)	Velocity during measurement $\leq V_s \times 20\%$	
	Standard Accuracy (Calibration Code A)	*)High Accuracy (Calibration Code U)
$1.0 \leq V_s \leq 10$	$\pm 0.1\%$ of Vs	$\pm 0.07\%$ of FS
$0.1 \leq V_s \leq 1.0$	$\pm 0.2(0.1/V_s+0.4)\%$ of Vs	$\pm 0.2(0.1/V_s+0.25)\%$ of Vs

*)High accuracy calibration is available for sizes of 40 to 125mm (1½ to 5 inches).

Reference Conditions for high accuracy calibration:

- Fluid: Tap water
- Fluid temperature: 15 to 30°C
- Ambient temperature: 15 to 30°C
- Ambient humidity: 30 to 70%
- Length of straight pipe:
Upstream > 20×DN
Downstream > 5×DN
(DN: Pipe diameter nominal)
- Properly grounded
- Properly centered

PHYSICAL SPECIFICATIONS

Main body material

Measuring pipe materials

SUS304 stainless steel

Case

SUS304 stainless steel

Terminal box

Aluminum alloy (remote model)

Corrosion-proof baked epoxy paint

Color

Light beige (Munsell 4Y7.2/1.3)

Process wetted materials

Lining

PFA (diameter 15 to 125 mm)

Electrode

SUS316L, Hastelloy C, Titanium

Ferrule for welding

SUS304, SUS316L

Gasket

EPDM (Ethylene propylene dien monomer)

Silicone rubber

Structure of electrode

Internal insertion (electrode can not be removed)

INSTALLATION

Electrical connection

Integral model

Connected to converter

Remote model

G1/2 (PF1/2) internal thread, 1/2 NPT internal thread, CM20 internal thread, Pg 13.5 internal thread

Pipe connection

IDF clamp (Size 15 to 125 mm (1/2 to 5 inches))

Tri-clamp (Size 15, 25, 40, 50, 80 mm (1/2, 1, 1½, 2, 3 inches))

Grounding

Resistance less than 100 Ω

Length of straight pipe

Upstream side

A minimum five straight pipe diameters

A minimum 10 straight pipe diameters is required if a diffuser/valve/pump is installed upstream side.

Downstream side

Two straight pipe diameters is recommended.

Cable (between remote detector and converter)

Maximum length

300 m (984 ft) (depending on fluid conductivity)

Outer diameter

10 to 12 mm (0.4 to 0.47 inch)

Signal cable

Dedicated cable model MGA12W (O.D. 11.4 mm, 0.75 mm² diameter) or equivalent (CVVS, CEEV, etc.)

Excitation cable

Dedicated cable model MGA12W (O.D. 10.5 mm, 2 mm² diameter) or equivalent (CVV and others)

MODEL SELECTION

Sanitary detector (15 to 125 mm (1/2 to 5 inches)) PFA lining

MGS28U - I II III IV V VI VII VIII - IX - Y W / Options (some options can be selected per each model)

Option “Y” must be specified for Yamatake version.

Option “W” must be specified for clamp.

Basic model no.		Selections						Optional selections	
MGS28U									
I	Line size	15 mm (1/2 inch)	015						
		25 mm (1 inch)	025						
		40 mm (1½ inches)	040						
		50 mm (2 inches)	050						
		80 mm (3 inches)	080						
		100 mm (4 inches)	100						
		125 mm (5 inches)	125						
II	Lining	PFA		P					
III	Pipe connection	IDF clamp		C1					
		Tri-clamp		C2					
IV	Electrodes	SUS316L			L				
		Hastelloy C			C				
		Titanium			K				
V	Ferrule for welding	SUS 304			E				
		SUS316L			S				
VI	Electrical connection / Watertight gland	Integral type				1			
		Remote type	G1/2 internal thread / without watertight gland				2		
			G1/2 internal thread / with brass (Ni-plated) watertight gland				3		
			G1/2 internal thread / with plastic watertight gland				4		
			1/2NPT internal thread / without watertight gland				5		
			CM20 internal thread / without watertight gland				6		
			Pg.13.5 internal thread / without watertight gland				7		
			G1/2 internal thread / with SUS304 watertight gland				8		
VII	Installation wiring direction	Integral type					H		
		Remote type	Upstream side (horizontal / vertical piping)					A	
			Downstream side (horizontal / vertical piping)					B	
			Horizontal piping mounting left side viewed from upstream					C	
			Horizontal piping mounting right side viewed from upstream					D	
VIII	Calibration	Standard calibration 3 point (0, 50, 100%) with master converter					A		
		+/- 0.35% of rate calibration (Size 40 to 125 mm (1 1/2 to 5 inches))					U		
		Others					<input type="checkbox"/>		
IX	Finish	Standard (corrosion-proof) finish						2	

Remote style

Option	Description	Code
	Yamatake version (must be selected)	Y
	Calibration certificate (sent to ordering location separately)	A
	Traceability certificate	B
	Attaching the Tag number plate to the terminal box (remote type detector) (Note 1)	K
	Attaching the TAG no. plate to the neck section	L
	With 2 pcs.of gaskets (gasket material : EPDM) (Note 2)	T
	Spare gaskets(additional 2 pcs. of gaskets) (Note 3)	V
	With 2 pcs.of gaskets (gasket material :Silicone rubber) (Note 2)	Q
	With clam (2 pcs.)	W

- Note) 1. Must be selected for Tag number requirement.
 2. Option “T” or “Q” must be specified for gasket.
 3. Spare gasket material is determined by the option code “T” or “Q”.

DIMENSIONS

All dimensions are in millimeters, dimensions in brackets () are in inches (inch).

Model MGS28U - Integral type

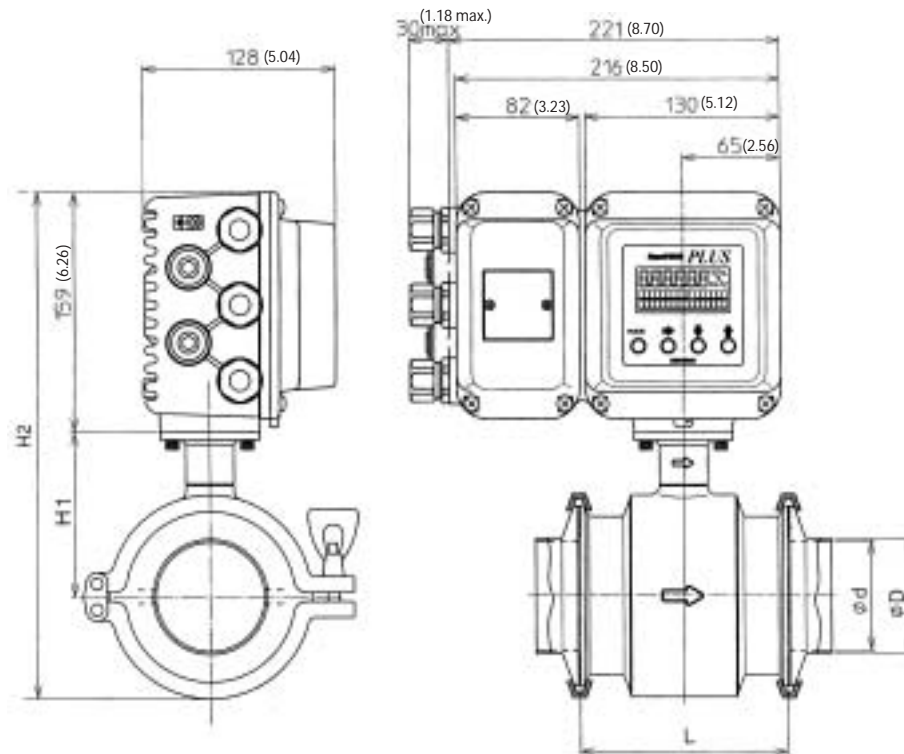

Size		mm	15	25	40	50	80	100	125
		(inches)	(1/2)	(1)	(1½)	(2)	(3)	(4)	(5)
Face to face dimension	L	mm	110	110	110	116	138	152	200
		(inches)	(4.33)	(4.33)	(4.33)	(4.57)	(5.43)	(5.98)	(7.87)
Inner diameter	ϕd	mm	15	23	35.7	47.8	72.3	97.6	133.8
		(inches)	(0.59)	(0.91)	(1.41)	(1.88)	(2.85)	(3.84)	(5.27)
Height	H1	mm	77	84	84	93	109	121	160
		(inches)	(3.03)	(3.31)	(3.31)	(3.66)	(4.29)	(4.76)	(6.30)
	H2	mm	270	290	290	306	336	359	429
		(inches)	(10.63)	(11.42)	(11.42)	(12.05)	(13.23)	(14.13)	(16.89)
Weight with converter	kg	6.2	6.2	6.2	6.8	9.5	10.1	21.8	
	(lb)	(13.67)	(13.67)	(13.67)	(14.99)	(20.94)	(22.27)	(48.06)	

Accessories

Size		mm	15	25	40	50	80	100	125
		(inches)	(1/2)	(1)	(1½)	(2)	(3)	(4)	(5)
Length of ferrule for welding	mm	28	28	28	28	28	28	28	62
	(inches)	(1.10)	(1.10)	(1.10)	(1.10)	(1.10)	(1.10)	(1.10)	(2.44)
Gasket thickness (1 pc)	mm	1.7	1.7	1.7	1.7	1.7	1.7	1.7	1.7
	(inches)	(0.07)	(0.07)	(0.07)	(0.07)	(0.07)	(0.07)	(0.07)	(0.07)
Outer diameter of ferrule for welding	ϕD	mm	17.3	25.4	38.1	50.8	76.3	101.6	139.8
		(inches)	(0.68)	(1.0)	(1.5)	(2.0)	(3.0)	(4.0)	(5.5)

Model MGS28U - Remote type

Terminal connection table

Mark	Description
X	Excitation current input
Y	
A	Flow rate signal output
B	
C	

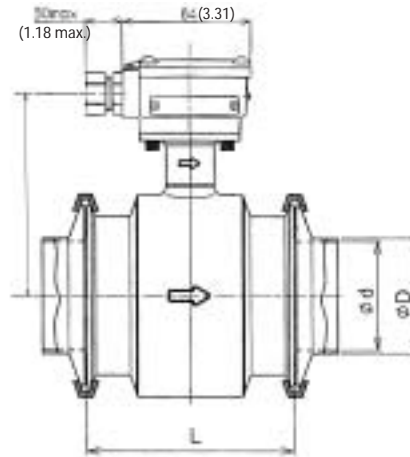
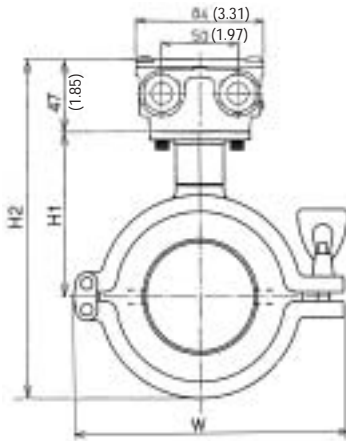
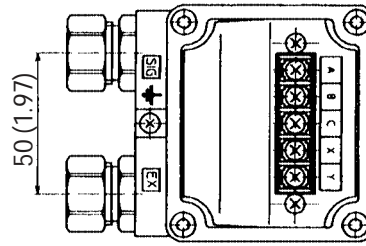

Size		mm	15	25	40	50	80	100	125
		(inches)	(1/2)	(1)	(1½)	(2)	(3)	(4)	(5)
Face to face dimension	L	mm	110	110	110	116	138	152	200
		(inches)	(4.33)	(4.33)	(4.33)	(4.57)	(5.43)	(5.98)	(7.87)
Inner diameter	φd	mm	15	23	35.7	47.8	72.3	97.6	133.8
		(inches)	(0.59)	(0.91)	(1.41)	(1.88)	(2.85)	(3.84)	(5.27)
Height	H1	mm	77	84	84	93	109	121	160
		(inches)	(3.03)	(3.31)	(3.31)	(3.66)	(4.29)	(4.76)	(6.30)
	H2	mm	158	178	178	194	224	247	317
		(inches)	(6.22)	(7.01)	(7.01)	(7.64)	(8.82)	(9.72)	(12.48)
Weight with converter		kg	2.6	2.8	2.8	3.4	6.1	6.7	18.4
		(lb)	(5.73)	(6.17)	(6.17)	(7.50)	(13.45)	(14.77)	(40.57)

Accessories

Size		mm	15	25	40	50	80	100	125
		(inches)	(1/2)	(1)	(1½)	(2)	(3)	(4)	(5)
Length of ferrule for welding		mm	28	28	28	28	28	28	62
		(inches)	(1.10)	(1.10)	(1.10)	(1.10)	(1.10)	(1.10)	(2.44)
Gasket thickness (1 pc)		mm	1.7	1.7	1.7	1.7	1.7	1.7	1.7
		(inches)	(0.07)	(0.07)	(0.07)	(0.07)	(0.07)	(0.07)	(0.07)
Outer diameter of ferrule for welding	φD	mm	17.3	25.4	38.1	50.8	76.3	101.6	139.8
		(inches)	(0.68)	(1.0)	(1.5)	(2.0)	(3.0)	(4.0)	(5.5)

Note

azbil

Yamatake Corporation
Advanced Automation Company

1-12-2 Kawana, Fujisawa
Kanagawa 251-8522 Japan

URL:<http://www.azbil.com>