

MagneW 3000 PLUS Smart Electromagnetic Flowmeter

HENRI Flowmeter for Pulp Slurry

Model MGH14C (Converter) / MGH18 (Detector)

OVERVIEW

The MagneW 3000 PLUS HENRI (High-Energy Noise-Resistant Instrument) flowmeter is a high-performance and highly reliable flowmeter for Pulp & Paper applications based on Yamatake's proven MagneW 3000 flow measurement technologies. The MagneW 3000 PLUS HENRI offers a stable and accurate measurement for severe Pulp and Paper applications with a unique lining manufacturing technology and high-frequency excitation technology.

FEATURES

Stable and accurate measurement by high-frequency excitation technology

- MagneW 3000 PLUS HENRI minimizes the output fluctuation caused by various noises (Slurry noise, AC noise and Electrochemical noise) and realizes stable and accurate flow measurement for pulp slurry applications.

High-performance lining

- A unique high quality lining technology makes it possible to offer mirror-finish PFA lining. The mirror-finish PFA lining is best suited for scaling applications.
- A new material ETFE (harder than PFA) lining is suitable for wearing applications in Pulp & Paper process. ETFE lining extends life-time of lining than (that of) PFA lining.

Replaceable face-to-face dimension detector (Optional)

- This detector can replace the detector of our existing models and those of other suppliers.

Please consult your Yamatake representative for details.

Rugged detector structure

- A stainless steel housing has been adopted for sizes 40 to 200 mm (1½ to 8 inches).
- A watertight structure is used for the watertight model (Model MGH18).



APPLICATIONS

Applications for pulp production, preparation and papermaking process

- Pulpstock flow to head box
- DIP (De-inked pulp) application
- Pulp from screen
- Green liquor
- Diluted black liquor
- Dye/pigment dosing application
- White liquor
- High consistency pulp
- Pulp from pulper

For converter (Model MGH14C)

FUNCTIONAL SPECIFICATIONS

Type of protection

JIS C 0920 waterproof model
NEMA ICS6-110 TYPE 4X
IEC PUBL 529 IP66

Input signal

Flow signal

Electromotive force from the detector

Contact input (optional)

Solid-state contact or no-voltage contact

Output signal

Analog output

4 to 20mA DC

Digital output

DE

Analog or digital output is selectable.

Contact output (optional)

Open collector

Contact capacity: 30 V DC max., 200mA max.

Pulse output (optional)

Open collector

Contact capacity: 30 V DC max., 200mA max.

Pulse frequency: 2000 Hz max.

Pulse width: 0.3 to 999.9 ms

Adjustable from 0.3 to 999.9 ms or fixed at 50% of duty

Analog output range/load resistance

Without SFC communication

0.8mA to 22.4mA (-20% to +115%)

Load resistance: 0 to 600 Ω

With SFC communication

3.2mA to 22.4mA (-5% to +115%)

External power source for communication

DC16V to 45V

Load resistance = (External power source for Communication - 8.5 V) / 0.025

With HART communication

Load resistance: 250 Ω minimum

Digital output range/load resistance

With SFC communication

3.2mA to 22.4mA (-5% to +115%)

External power source for SFC communication/digital communication 16 to 45 V DC

Load resistance

= (External power source for Communication - 8.5V)/0.025

Unit of flow indication

Volume flow

m³, L, cm³, G, mG, kG, B

Mass flow

t, kg, g, lb

Time

d, h, min, s

Damping time

Adjustable between 0.5 and 199.9 seconds

Low flow cutoff

Adjustable between 0 to 10% of setting range.

Below selected value, output is driven to the zero flow rate signal level.

Drop out

Adjustable between 0 to 10% of setting range.

Below selected value, pulse output is cut.

Lightning protection

12 kV, 1000A

Equipped with the lightning arrester in the power source and external input and output terminals.

Power failure

An EEPROM retains data record of totalized value when pulse output is used (retention period approximately 10 years).

Power supply

90 to 246 V AC

Power supply frequency

47 to 63 Hz

Power consumption

30 W max.

Ambient temperature limits

-25 to +50°C (-13 to +122°F)

Ambient humidity limits

5 to 100% RH

Optional specifications

Display Indication by LCD with backlighting

Main display

7-segment, 6 digits

Sub display

16 digits, 2 lines

Display contents

Demonstrates three values simultaneously.

- Flow volume in percentage
- Actual flow volume
- Totalized value (when pulse output selected)

Selection of main display and sub display

Main display is selectable from the three values.

Data setting device

Setting by infrared ray touch sensor

Infrared ray touch sensor: Four key switches

Contact input function

External 0% lock input

Forces outputs (analog, digital, pulse) to the zero flow rate signal level.

Activates by applying a contact input.

External automatic zero adjustment input

Adjusts zero-point.

Activates by applying a contact input.

External range switching input

Switches two flow measurement ranges.

Two measurement ranges

- Dual range for normal directions
- Normal/reverse range

Activates by applying a contact input.

Built-in counter reset input (for pulse output model)

Resets the totalized value of the built-in counter.

Activates by applying a contact input.

Contact output function

Alarm output

Outputs an alarm under the following conditions.

- Self-diagnostic result
- Empty detection
- High/low limit alarm

Range switching output

- Outputs the status of flow range.
- Large/small in dual range
- Normal/ Reverse

Counter preset status output (for pulse output model)

Activates when the counter reaches the preset value.

Self-check result output

Activates only when a self-diagnostic abnormality occurs.

Empty detection output

Activates only when an empty status is detected.

High/low limit alarm output

Activates when a high/low limit alarm occurs.

Two-stage flow rate alarm output (with two contact outputs)

Activates when the first high/low limit alarm (H/L) occurs and the second high/low limit alarm (HH/LL) occurs.

Empty pipe detection

When the detector is empty, the analog output, digital output and pulse output are fixed at zero. Display is latched to zero.

Pulse output

Outputs the totalized value.

Must be selected in case of using totalizer.

Built-in counter function

Totalizer

According to the pulse scale setting, it totals one count at a time, for normal and reverse flows.

Totalizer with presetting function

A preset value (target totalized value) can be set between 0000000000 and 9999999999. The counting method is same as that of the standard totalizer.

Normal/reverse flow difference totalizer

The difference in flow volumes in the normal and reverse directions is calculated and displayed.

Traceability certificate

The following three documents are provided.

- Traceability System Chart
- Traceability Certificate
- Test Report

Tropicalization treatment

Protects the electromagnetic flow meter in harsh environments during transportation and/or storage. The following treatments are applied.

- Corrosion protection
- Moisture prevention
- Mildew proofing

Indication other than SI units

The following non-SI units are available.

Volume unit

B (barrel), kG (kilo-gallon), G (gallon), mG (milli-gallon)

Mass unit

lb (pound)

PHYSICAL SPECIFICATION**Housing material**

Aluminum alloy

Finish**Standard**

Baked acryl paint

Corrosion-resistant

Baked acryl paint

Corrosion-proof

Baked epoxy paint

Color

Light beige (Munsell 4Y7.2/1.3)

Display cover material

Tempered glass, 5 mm thick

Weight

3.7 kg (8.2 lb)

INSTALLATION

Model MGH18 detector must be coupled with model MGH14C converter.

Electrical connection

G1/2 (PF1/2) internal thread, 1/2NPT internal thread, CM20 internal thread, Pg13.5 internal thread

Mounting

Wall mounting, 2-inch pipe mounting

Grounding

Resistance less than 100 Ω

.....
For detector (Model MGH18)

FUNCTIONAL SPECIFICATIONS**Type of protection**

JIS C 0920 watertight model

NEMA ICS6-180 TYPE 4X

IEC PUBL 529 IP67

Size**Wafer style**

40, 50, 80, 100, 150, 200 mm

(1½, 2, 3, 4, 6, 8 inches)

Flange style

40, 50, 80, 100, 150, 200, 250, 300, 350, 400 mm

(1½, 2, 3, 4, 6, 8, 10, 12, 14, 16 inches)

Flange rating

JIS 10K, JIS 16K, JIS 20K, JIS 30K,

JPI 50, JPI 300, ANSI 150, ANSI 300,

DIN PN10, DIN PN16, DIN PN25, DIN PN40

(Size 40 to 200 mm (1½ to 8 inches))

JIS 10K, JIS 20K,

JPI 150, JPI 300,

ANSI 150, ANSI 300,

DIN PN10, DIN PN16, DIN PN25

(Size 250 to 400 mm (10 to 16 inches))

Ambient temperature limits

-30 to +80°C (-22 to +176°F)

Ambient humidity limits

5 to 100% RH

Measurable electrical conductivity

Coupled with model MGH14C converter

20 μS/cm or greater

(In case of less than 20 μS/cm, consult your Yamatake representative.)

Temperature range pressure range process fluid

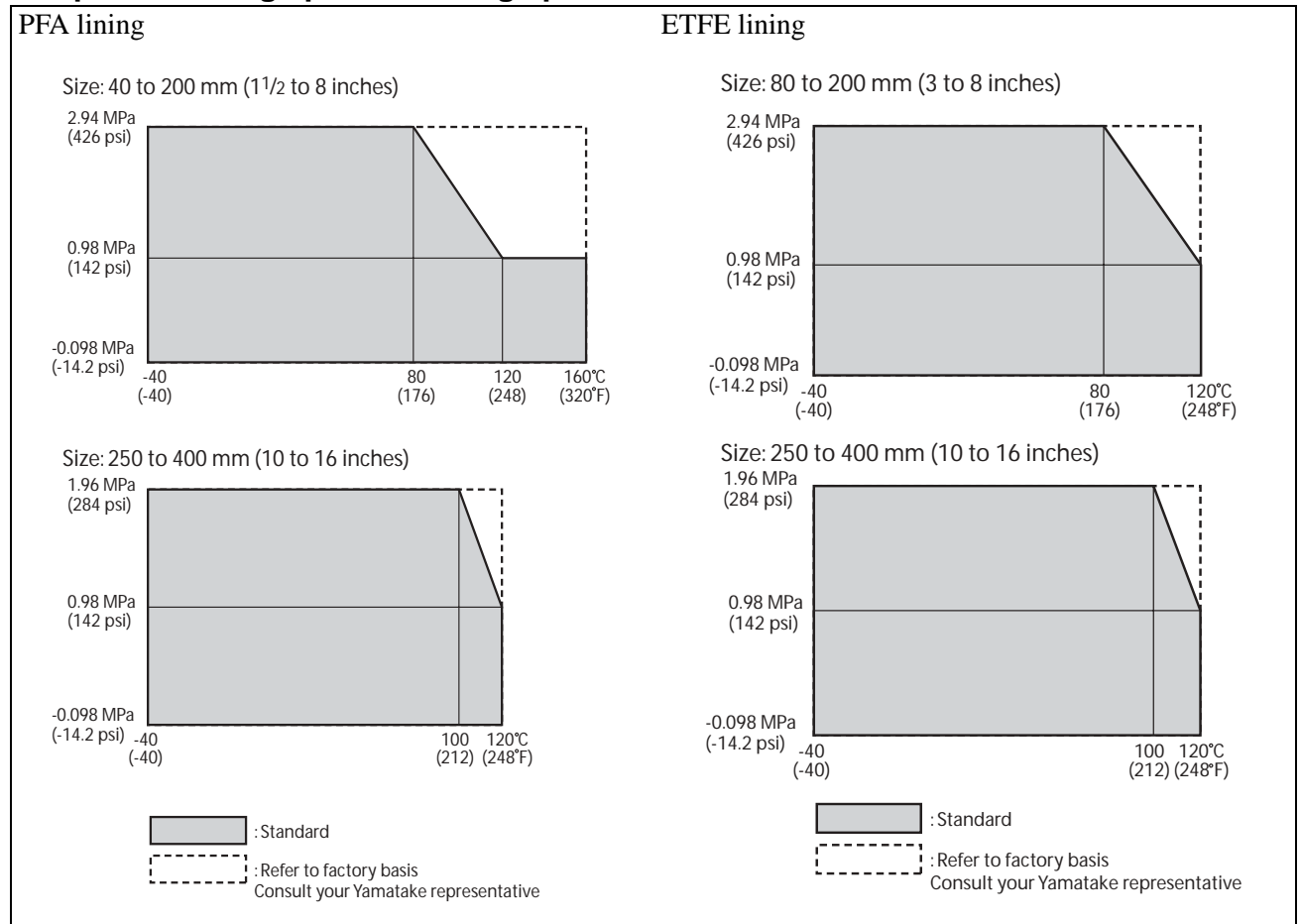

Measurement flow range

Size		Minimum flow velocity range is 0 to 0.3 m/s (0 to 0.98 ft/s)		Maximum flow velocity range is 0 to 10m/s (0 to 32.8 ft/s)		Conversion factor K
		Minimum range		Maximum range		
mm	inches	m ³ /h	GPM	m ³ /h	GPM	
40	1 1/2	0 to 1.358	0 to 5.976	0 to 45.23	0 to 199.1	0.2210
50	2	0 to 2.121	0 to 9.337	0 to 70.68	0 to 311.2	0.1415
65	2 1/2	0 to 3.584	0 to 15.78	0 to 119.4	0 to 525.9	0.08371
80	3	0 to 5.429	0 to 23.90	0 to 180.9	0 to 796.7	0.05526
100	4	0 to 8.483	0 to 37.35	0 to 282.7	0 to 1244	0.03537
150	6	0 to 19.09	0 to 84.04	0 to 636.1	0 to 2801	0.01572
200	8	0 to 33.93	0 to 149.4	0 to 1130	0 to 4979	0.008842
250	10	0 to 53.02	0 to 233.5	0 to 1767	0 to 7781	0.005659
300	12	0 to 76.35	0 to 336.2	0 to 2544	0 to 11205	0.003930
350	14	0 to 104.0	0 to 457.6	0 to 3463	0 to 15251	0.002887
400	16	0 to 135.8	0 to 597.7	0 to 4523	0 to 19920	0.002210

Velocity V(m/s) = K × Q

K = Flow conversion factor = 1/3600 × 4/(πD²)

Q = Flow rate (m³/h)

Optional specifications

Test report

Calibration certificate, withstand voltage test, insulation resistant, hydrostatic pressure test, physical inspection are included.

Traceability certificate

The following three documents are included.

- Traceability System Chart
- Traceability Certificate
- Test Report

Material certificate

Material certificate for electrode/grounding ring

Gasket for plastic piping

When the detector is being mounted on plastic pipe, attach this gasket between the lining and the grounding ring, and between the grounding ring and the plastic pipe flange.

Attaching the tag number to the terminal box

Stamp the tag with the specified number and attach to the terminal box. The maximum number of characters of the tag number is 8.

Attaching the tag number to the neck section

Stamp the tag with the specified number and attach to the neck section of the detector with stainless wire. The maximum number of characters of the tag number is 16.

PERFORMANCE SPECIFICATIONS

Accuracy (model MGH14C with model MGH18 detector)

Vs = velocity of setting range

Vs (m/s)	Velocity during measurement \geq Vs \times 20%	Velocity during measurements \leq Vs \times 20%
$1.0 \leq Vs \leq 10$	$\pm 0.5\%$ of rate	$\pm 0.1\%$ of Vs
$0.3 \leq Vs \leq 1.0$	$\pm(0.1/Vs+0.4)\%$ of rate	$\pm 0.2(0.1/Vs+0.4)\%$ of Vs

PHYSICAL SPECIFICATIONS

Main body material

Measuring pipe material

SUS304 stainless steel

Flange

SUS304 stainless steel

(Size 40 to 50 mm (1½ to 2 inches))

Carbon steel + corrosion-preventive painting

(Size 80 to 400 mm (3 to 16 inches))

Housing

SUS304 stainless steel

(Size 40 to 200 mm (1½ to 8 inches))

Carbon steel

(Size 250 to 400 mm (10 to 16 inches))

Terminal box

Aluminum alloy

Finish

Standard

Terminal box

Baked acryl paint

Case (size 250 to 400 mm (10 to 16 inches))

Polyurethane paint

Corrosion-resistant

Terminal box

Baked acryl paint

Case (size 250 to 400 mm (10 to 16 inches))

Polyurethane paint

Corrosion-proof

Terminal box

Baked epoxy paint

Case (size 250 to 400 mm (10 to 16 inches))

Epoxy paint

Color

Light beige (Munsell 4Y7.2/1.3)

Process wetted materials

Lining

PFA (Size 40 to 400 mm (1½ to 16 inches))

ETFE (Size 80 to 400 mm (3 to 16 inches))

Electrode

SUS316L, Hastelloy C, titanium, zirconium, tantalum, tungsten-carbide, platinum-iridium

Grounding ring

SUS316, Hastelloy C, titanium, zirconium, tantalum, platinum

Gasket

PTFE (if grounding ring material is exotic.)

INSTALLATION

Electrical connection

G1/2 (PF1/2) internal thread
1/2NPT internal thread
CM20 internal thread
Pg13.5 internal thread

Pipe connection

Wafer (Size 40 to 200 mm (1½ to 8 inches))
Flange (Size 40 to 400 mm (1½ to 16 inches))

Grounding

Resistance less than 100 Ω

Length of straight pipe

Upstream side

A minimum five straight pipe diameters
A minimum 10 straight pipe diameters is required if
a diffuser/valve/pump is installed upstream side.

Downstream side

Two straight pipe diameters is recommended.

Cable (between remote detector and converter)

Maximum length 300 m (984 ft)
(depends on fluid conductivity)
Outer diameter 10 to 12 mm (0.4 to 0.47 inch)

Signal cable

Dedicated cable: MGA12W
(O.D. 11.4 mm, 0.75 mm²) or equivalent (CVVS,
CEEV etc.)

Excitation cable

Dedicated cable: MGA12W
(O.D. 10.5 mm, 2 mm²) or equivalent (CVV and
others)

MODEL SELECTION

Type / Basic model No.	Lining material	Pipe connection	Size mm (inches)		Page
Waterproof converter model MGH14C					page 8
Watertight detector model MGH18D	PFA / ETFE	Wafer	40 to 200	1½ to 8	page 9
Watertight detector model MGH18F	PFA / ETFE	Flange	40 to 400	1½ to 16	page 10

HENRI converter

Model MGH14C converter must be coupled with model MGH18 HENRI type detector

Model MGH14C - I II III IV - V VI VII VIII - Y / Options (some options can be selected per each model)

Option “Y” must be specified for Yamatake version.

Basic model no.		Selections				Optional selections			
MGH14C									
I	Power supply	90-264 V AC 50/60 Hz			M				
II	output signal / communication	Volume flow 4-20mA DC output / without communication			A				
		Volume flow 4-20mA DC output / with communication			B				
		Volume flow DE output / with communication			C				
		Volume flow HART protocol output / with communication			H				
III	Electrical connection / watertight gland	G1/2 internal thread / without watertight gland			1				
		G1/2 internal thread / with brass (Ni-plated) watertight gland			2				
		G1/2 internal thread / with plastic watertight gland			3				
		1/2NPT internal thread / without watertight gland			4				
		CM20 internal thread / without watertight gland			5				
		Pg13.5 internal thread / without watertight gland			6				
		G1/2 internal thread / with SUS304 watertight gland			7				
IV	Installation / wiring direction	Remote type	Wall mounting with standard bracket		G				
			2-inch pipe mounting with standard bracket		H				
			Without mounting bracket		X				
V	Finish	Standard				X			
		Corrosion-resistant finish				1			
		Corrosion-proof finish				2			
VI	Display	None				X			
		Main display: Instantaneous indication of flow volume in %				A			
		Main display: Instantaneous indication of actual flow volume				B			
		Main display: Indication of integrated flow volume (need pulse output board) Note 1				C			
VII	Contact inputs / outputs	None					X		
		1 input and 1 output (ranging function, warning for contact input/output, etc.)					1		
		2 input (ranging function, external automatic zero adjustment input, etc.)					2		
		2 output (ranging function, warning for contact output, etc.)					3		
VIII	Style code	None						X	

Options	Yamatake version (must be selected)	Y
	Empty pipe detection function	A
	Pulse output (open collector)	B
	Traceability certificate for converter	C
	Indication other than SI units	H
	Attachment of the TAG number to the terminal box for converter	J

Note) 1. In case of this code, option “B” must be selected.

HENRI detector

Wafer type (40 to 200 mm (1½ to 8 inches)) PFA / ETFE liner

Model MGH18D detector must be coupled with MGH14C converter

Model MGH18D - I II III IV V VI VII VIII IX - X XI - Y/Options (some options can be selected per each model)

Option “Y” must be specified for Yamatake version

Basic model no.		Selections				Optional selections			
MGH18D									
I	Line size	40 mm (1½ inches)	040						
		50 mm (2 inches)	050						
		80 mm (3 inches)	080						
		100 mm (4 inches)	100						
		150 mm (6 inches)	150						
		200 mm (8 inches)	200						
II	Linear	ETFE (Size 80 to 200 mm (3 to 8 inches))	E						
		PFA	P						
III	Piping connection	Wafer JIS 10K	11						
		Wafer JIS 20K	12						
		Wafer JIS 30K	13						
		Wafer ANSI 150	21						
		Wafer ANSI 300	22						
		Wafer DIN PN10	41						
		Wafer DIN PN16	42						
		Wafer DIN PN25	43						
		Wafer DIN PN40	44						
		Wafer JPI 150	61						
		Wafer JPI 300	62						
IV	Electrode	SUS316L	L						
		Hastelloy C	C						
		Titanium	K						
		Zirconium	H						
		Tantalum	T						
		Tungsten carbide	W						
		Platinum iridium	P						
		Others	<input type="checkbox"/>						
V	Grounding ring	SUS316	S						
		Hastelloy C	C						
		Titanium	K						
		Zirconium	H						
		Tantalum	T						
		Platinum iridium	P						
		Others	<input type="checkbox"/>						
VI	Electrical connection / watertight gland	Remote type	G1/2 internal thread / without watertight gland	2					
		G1/2 internal thread / with brass (Ni-plated) watertight gland	3						
		G1/2 internal thread / with plastic watertight gland	4						
		1/2NPT internal thread / without watertight gland	5						
		CM20 internal thread / without watertight gland	6						
		Pg13.5 internal thread / without watertight gland	7						
		G1/2 internal thread / with SUS304 watertight gland	8						
VII	Face-to-face dimensions	Standard				A			
		Others	<input type="checkbox"/>						
VIII	Installation / wiring direction	Remote type	Upstream side (horizontal / vertical piping mounting)			A			
		Downstream side (horizontal / vertical piping mounting)			B				
		Horizontal piping mounting / left side viewed from upstream			C				
		Horizontal piping mounting / right side viewed from upstream			D				
IX	Calibration	Standard				A			
		Others	<input type="checkbox"/>						
X	Finish	Standard					X		
		Corrosion-resistant finish					1		
		Corrosion-proof finish					2		
XI	Bolt / nut	None					X		
		Carbon steel					1		
		SUS304					2		

Options		
	Yamatake version (must be selected)	Y
	Calibration certificate (sent to ordering location separately)	A
	Traceability certificate for detector	B
	Material certificate (only for electrodes and ground rings)	C
	With gasket for plastic piping	J
	Attachment of the TAG number to the terminal box for detector (Note 1)	K
	Attachment of the TAG number plate to neck section for detector (Note 1)	L

Note) 1. Must be selected for Tag no. requirement

HENRI detector

Flange type (40 to 400 mm (1½ to 16 inches)) PFA / ETFE liner

Model MGH18F - I II III IV V VI VII VIII IX X - XI - Y/Options (some options can be selected per each model)

Option “Y” must be specified for Yamatake version

Basic model no.		Selections				Optional selections			
MGH18F									
I	Line size	40 mm (1½ inches)	040						
		50 mm (2 inches)	050						
		80 mm (3 inches)	080						
		100 mm (4 inches)	100						
		150 mm (6 inches)	150						
		200 mm (8 inches)	200						
		250 mm (10 inches)	250						
		300 mm (12 inches)	300						
		350 mm (14 inches)	350						
II	Linear	ETFE (Size 80 to 400 mm (3 to 16 inches))	E						
		PFA	P						
III	Piping connection	Flange JIS 10K	J1						
		Flange JIS 20K	J2						
		Flange JIS 30K	J3						
		Flange ANSI 150	A1						
		Flange ANSI 300	A2						
		Flange DIN PN10	D1						
		Flange DIN PN16	D2						
		Flange DIN PN25	D3						
		Flange DIN PN40	D4						
		Flange JPI 150	P1						
		Flange JPI 300	P2						
IV	Flange material	Standard	1						
V	Electrode	SUS316L	L						
		Hastelloy C	C						
		Titanium	K						
		Zirconium	H						
		Tantalum	T						
		Tungsten carbide	W						
		Platinum iridium	P						
		Others	<input type="checkbox"/>						
VI	Grounding ring	SUS316	S						
		Hastelloy C	C						
		Titanium	K						
		Tantalum	T						
		Platinum iridium	P						
		Others	<input type="checkbox"/>						
VI	Electrical connection / watertight gland	Remote type	G1/2 internal thread / without watertight gland	2					
		G1/2 internal thread / with brass (Ni-plated) watertight gland	3						
		G1/2 internal thread / with plastic watertight gland	4						
		1/2NPT internal thread / without watertight gland	5						
		CM20 internal thread / without watertight gland	6						
		Pg13.5 internal thread / without watertight gland	7						
		G1/2 internal thread / with SUS304 watertight gland	8						
VIII	Face-to-face dimensions	Standard	A						
		Others	<input type="checkbox"/>						
IX	Installation / wiring direction	Remote type	Upstream side (horizontal / vertical piping mounting)	A					
		Downstream side (horizontal / vertical piping mounting)	B						
		Horizontal piping mounting / left side viewed from upstream	C						
		Horizontal piping mounting / right side viewed from upstream	D						
X	Calibration	Standard	A						
		Others	<input type="checkbox"/>						
XI	Finish	Standard	X						
		Corrosion-resistant finish	1						
		Corrosion-proof finish	2						

Options		
Yamatake version (must be selected)	Y	
Calibration certificate (sent to ordering location separately)	A	
Traceability certificate for detector	B	
Material certificate (only for electrodes and ground rings)	C	
With gasket for plastic piping	J	
Attachment of the TAG number to the terminal box for detector (Note 1)	K	
Attachment of the TAG number plate to neck section for detector	L	

Note) 1. Must be selected for Tag no. requirement

DIMENSIONS

All dimensions are in millimeters, dimensions in brackets () are in inches (inch).

Wafer type

Size: 40 to 200 mm (1½ to 8 inches)

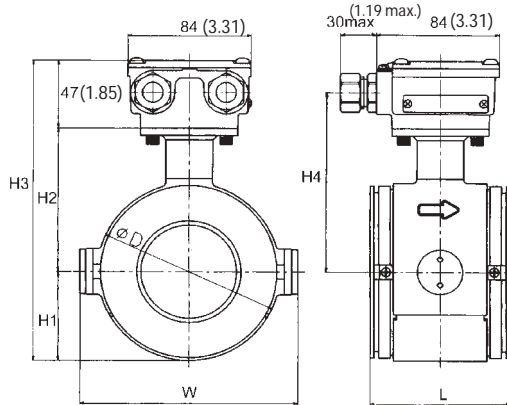

Size		mm	40	50	80	100	150	200
		(inches)	(1½)	(2)	(3)	(4)	(6)	(8)
Face to face dimension	L	mm	80	86	106	120	160	200
		(inches)	(3.15)	(3.39)	(4.17)	(4.72)	(6.30)	(7.87)
Height	H1	mm	84	93	108	120.5	160	185
		(inches)	(3.31)	(3.66)	(4.25)	(4.74)	(6.30)	(7.28)
	H2	mm	43.5	52	67	79.5	110	135
		(inches)	(1.71)	(2.05)	(2.64)	(3.13)	(4.33)	(5.31)
	H3	mm	174.5	192	222	247	317	367
		(inches)	(6.87)	(7.56)	(8.74)	(9.72)	(12.48)	(14.45)
	H4	mm	109	118	133	145.5	185	210
		(inches)	(4.29)	(4.65)	(5.24)	(5.73)	(7.28)	(8.27)
Housing width	W	mm	125	135	164	189	240	290
		(inches)	(4.92)	(5.31)	(6.46)	(7.44)	(9.45)	(11.42)
Housing outer diameter	φD	mm	87	104	134	159	220	270
		(inches)	(3.43)	(4.09)	(5.28)	(6.26)	(8.66)	(10.63)
Weight		kg	2.8	3.4	5.2	6.7	13.6	22.0
		(lb)	(6.2)	(7.5)	(11.5)	(14.8)	(30.0)	(48.5)

Flange type

Size: 40 to 400 mm (1½ to 16 inches)

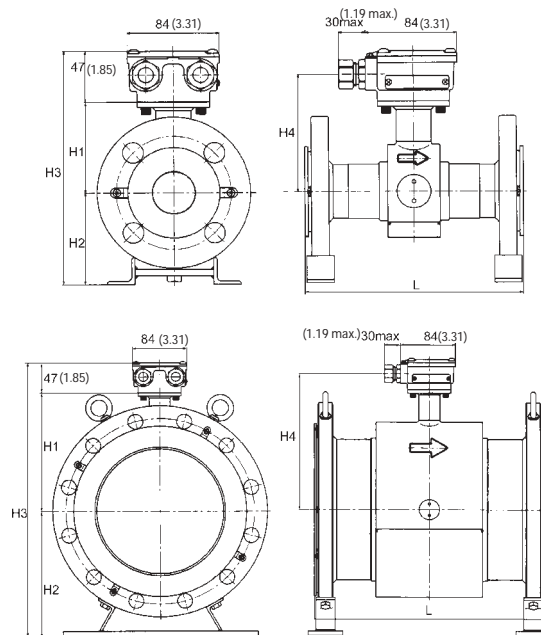

Size		mm	40	50	80	100	150	200	250	300	350	400
		(inches)	(1½)	(2)	(3)	(4)	(6)	(8)	(10)	(12)	(14)	(16)
Face to face dimension	L	mm	200	200	200	250	300	350	450	500	550	600
		(inches)	(7.87)	(7.87)	(7.87)	(9.84)	(11.81)	(13.78)	(17.72)	(19.69)	(21.65)	(23.62)
Height	H1	mm	84	93	108	120.5	160	185	235	258	282	310
		(inches)	(3.31)	(3.66)	(4.25)	(4.74)	(6.30)	(7.28)	(9.25)	(10.16)	(11.10)	(12.20)
	H2	mm	77	88	113	131	174	204	224	271	297	340
		(inches)	(3.03)	(3.46)	(4.45)	(5.16)	(6.85)	(8.03)	(8.82)	(10.67)	(11.09)	(13.39)
	H3	mm	208	228	268	299	381	436	506	576	626	697
		(inches)	(8.19)	(8.98)	(10.55)	(11.77)	(15.0)	(17.17)	(19.92)	(22.68)	(24.65)	(27.44)
	H4	mm	109	118	133	145.5	185	210	260	283	307	335
		(inches)	(4.29)	(4.65)	(5.24)	(5.73)	(7.28)	(8.27)	(10.24)	(11.14)	(12.09)	(13.19)
Weight		kg	6.0	10.5	15.5	23.3	35.4	60.0	68.0	97.0	128.0	163.0
		(lb)	(13.2)	(23.1)	(34.2)	(51.4)	(78.0)	(132)	(150)	(214)	(282)	(359)

Note) The table indicates dimensions for ANSI 150 flange

Wall mount type

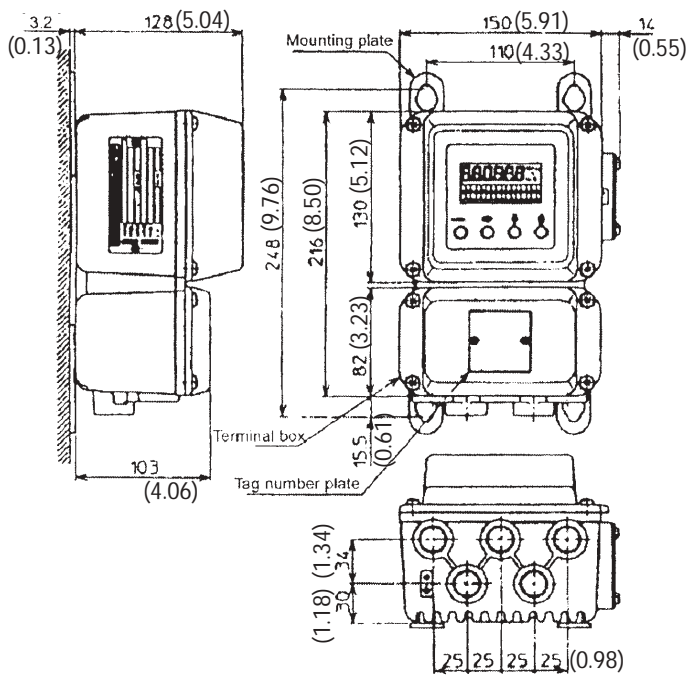

2-inch pipe mount type

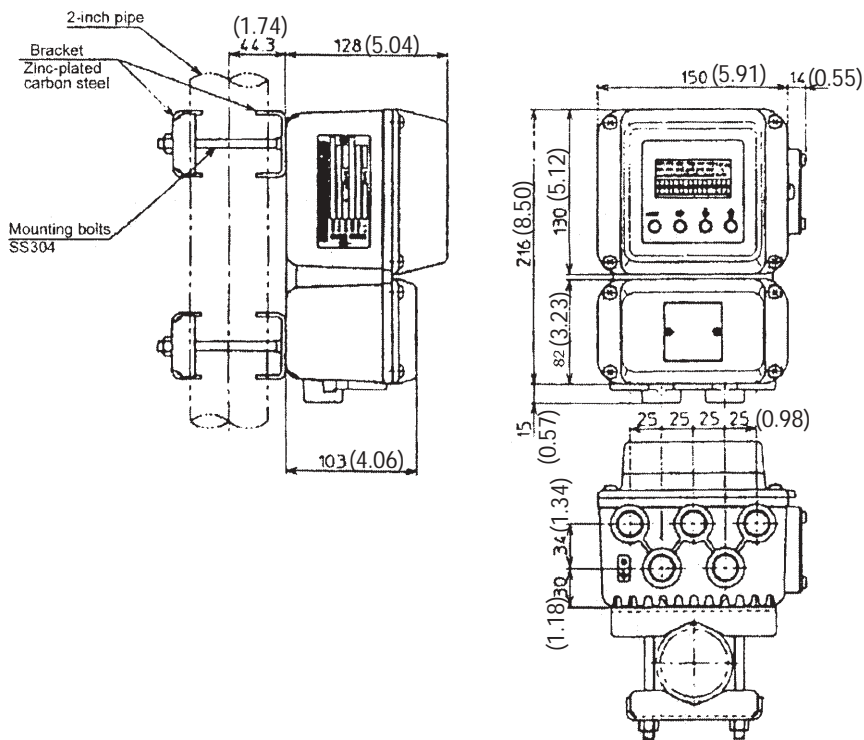

Yamatake Corporation
Advanced Automation Company

1-12-2 Kawana, Fujisawa
Kanagawa 251-8522 Japan

URL: <http://www.azbil.com>