

# MagneW3000 PLUS<sup>+</sup>

## Smart Electromagnetic Flowmeter Converter (Smart model)

### Model MGG14C

#### OVERVIEW

MagneW 3000 PLUS<sup>+</sup> electromagnetic flowmeter converter is a high-performance and highly reliable flowmeter converter based on Yamatake's proven MagneW 3000 PLUS flow measurement technologies. The MagneW PLUS<sup>+</sup> converter offers expanded flow rate measurement capabilities in the various processes when used with the MagneW detectors.

#### FEATURES

##### **Improved performance and function**

- Improved noise immunity performance up to 250%.
- Averaging function for pulsating flow applications has been added.
- User selectable functionality provides advanced noise immunity technology such as auto spike cut function and excitation frequency change.
- Optional "Fast Response" model for short run batch applications.

##### **Universal power supply**

- AC 90 to 130V, AC 180 to 250V.

##### **Liquid Crystal Display with backlighting (optional)**

- Backlit display eases reading in direct sunlight or poor lighting conditions.
- Simultaneously displays flow volume in percentage, actual flow rate and totalized value.
- Rotating display improves visibility of integral models mounted on pipes up to 90 degrees from standard.



(Remote converter)

##### **Setting parameters by infrared touch sensor (optional)**

- Allows safe setting, in severe environments, without opening the cover.
- Write protect function prevents tampering with converter settings.

##### **Compatibility**

- MagneW 3000 PLUS<sup>+</sup> converter is compatible with all conventional Yamatake detectors.

##### **Conforms with the CE marking**

Conform with the RoHS (restriction of the use of certain hazardous substances in electrical and electronic equipment)

##### **China RoHS**

This device is used in the Oil & Gas, Petrochemical, Chemical, Pulp & Paper, Food & Beverage, Machinery, Steel/Metal & Mining, and Automobile industries and therefore does not fall under the China RoHS Legislation.

If this device is used in equipment or applications which fall under the China RoHS, labeling on the device and documents for the China RoHS may be required. If such documents are required, consult a Yamatake representative.

**COMMUNICATION(SELECTABLE)**

- Yamatake/Honeywell DE protocol
- HART protocol (HART Rev. 5)

**APPLICATIONS**

Available for various applications such as:

**Pulp and Paper**

Pulp slurries, chemicals, green liquor, white water, white liquor, black liquor, corrosive fluid, industrial water, waste water

**Petroleum/Petrochemical/Chemicals**

Corrosive fluid, electrolyte, dyestuffs, chemicals, industrial water, waste water

**Water/Waste water**

Tap water, sewage water, sludge, sediment slurries, effluent

**Food and Beverage**

Beer, milk, juice, wine, liquor, soy sauce, potable water, industrial water, waste water

**Steel/Metal and Mining**

Alumina slurry, cooling water, sea water, corrosive fluid, industrial water, waste water

**Machinery**

Corrosive fluid, cooling water, circulating water, waste water

**Building/Construction**

Building material slurry, sediment slurry, cement, industrial water

**Electric Power/Gas**

Corrosive fluid, cooling water, industrial water, waste water

**FUNCTIONAL SPECIFICATIONS****Type of protection****Enclosure rating**

JIS C 0920 Waterproof  
NEMA TYPE4X  
IEC IP66

**Hazardous area certification:****FM approval**

<for Division 2>

Nonincendive for

Class I, Division 2, Groups A, B, C & D, T5;

Class II, Division 2, Groups F & G, T5;

Class III, Division 2, T5;

-25°C ≤ Tamb ≤ +60°C

**CSA certification**

<for Division 2>

Class I, Division 2, Groups A, B, C, & D, T4;

Class II, Division 2, Groups E, F & G, T4;

Class III, T4;

-25°C ≤ Tamb ≤ +60°C

**Power supply****Normal operating voltage:**

AC 100 to 120V, AC200 to 240V, 47 to 63Hz

**Operational voltage limit:**

AC 90 to 130V, AC180 to 250V, 47 to 63Hz

**Power consumption**

10W max. (AC90 to 130V)

11W max. (AC180 to 250V)

**Lightning protection**

12kV, 1000A

Equipped with the lightning arrester in the power source and external input and output terminals.

**Power failure**

An EEPROM retains data record of the totalized value when pulse output is used (retention period approximately 10 years).

**EMC conformity standards**

EN61326

**Input signal****Flow rate signal**

Electromotive force which is proportional to the average flow velocity.

**Contact input**

Solid-state contact or no-voltage contact (2 max.)

**Output signal****Analog output**

4 to 20mA DC

**Digital output**

DE

Analog or digital output is selectable.

**Contact output**

Open collector (2 max.)

**Contact capacity**

DC30V max., 200mA max.

**Pulse output**

Open collector

**Contact capacity**

DC30V max., 200mA max.

**Pulse Frequency**

0.00006 to 3000 Hz

**Pulse width**

adjustable from 0.10 to 999.99 ms or fixed at 50% of the duty (In case of pulse frequency is 0.00006 to 0.5Hz, pulse width is fixed at 1sec.)

Voltage drop during transistor ON: 2.7V typ.

(Voltage drop can be reduced to 2.0 V by a switch)

**Analog output range/load resistance****Without SFC communication**

0.8 to 22.4mA (-20 to +115%)

Load resistance: 0 to 600Ω

**With SFC communication**

3.2 to 22.4mA (-5 to +115%)

External power supply required for SFC communication: 16 to 45V DC

Load resistance (Ω) = (External power supply voltage -8.5V)/0.025

**With HART communication by using Internal power supply**

3.2 to 22.4mA (-5 to +115%)

Load resistance: 0 to 600Ω

**With HART communication by using an external power supply**

3.2 to 22.4mA (-5 to +115%)

External power supply required for HART communication: 16 to 45V DC

Load resistance (Ω) = (External power supply voltage -8.5V)/0.025

**Fast response type/no communication function**

0.8 to 22.4mA (-20 to +115%)

Load resistance: 0 to 600Ω

**Digital output range/load resistance**

With DE output

3.2 to 22.4mA (-5 to +115%)

External power supply required for DE communication: 16 to 45V DC

Load resistance (Ω) = (External power supply voltage -8.5V)/0.025

**Unit of flow rate**

Selectable from%, volumetric flow rate unit, mass flow rate unit, time.

Volumetric flow rate: m<sup>3</sup>, l, cm<sup>3</sup>, B (barrel), G (gallon), kG, mG, IG (imperial gallon),

Mass flow rate: t, kg, g, lb (pound)

Time: d, h, min., s

*Note) Selection for non-SI unit, option code "H" must be selected.***Operation Mode**

MEASURING MODE:

Mode for flow rate measurement

BASIC SETUP MODE:

Mode for quick start-up

ENGINEERING MODE

Mode for parameter configuration (Range, pulse scale, etc.)

MAINTENANCE MODE

Mode for maintenance

ADVANCED MODE

Mode for advanced functions

**Auto zeroing function (in the BASIC SETUP MODE)**

Adjust zero automatically

**Damping (in the BASIC SETUP MODE)**

Adjustable between 0.1 and 199.9 seconds

Fast response type: Adjustable between 0 and 199.9 seconds

**Averaging function (in the ADVANCED MODE)**

Moving average processing of the measured flow rate

ON/OFF, Adjustable between 1.0 and 30.0 seconds

**Spike cut function (in the ADVANCED MODE)**

Eliminates steep noise spikes.

Auto/Manual/OFF

**Low flow cutoff**

Adjustable between 0 and 10% of setting range

Below selected value, output is driven to the zero flow rate signal level.

**Drop out**

Adjustable between 0 and 10% of setting range

Below selected value, pulse output is fixed at 0%.

**Fail-safe mode**

Determine analog/pulse output direction when the flow meter detects a critical status condition.

LOW/HIGH/HOLD

**Compensation coefficient (in the ADVANCED MODE)**

Compensation coefficient used to multiply the output flow rate as required.

**Built-in counter function****Totalizer**

According to the pulse scale setting, it totals one count at a time. If double range of normal/reverse flow measurement function is set, it totals one count at a time for normal and reverse flows. If single range of flow measurement is set, it totals one count at a time only for normal flow direction.

**Totalizer with presetting function**

A preset value (target totalized value) can be set between 0000000000 and 9999999999.

The counting method is same as that of the standard totalizer.

**Normal/reverse flow difference totalizer**

The difference in flow volumes in the normal or reverse flow directions is calculated and counted.

**Contact input function****External 0% lock input**

Forces outputs (analog, digital, pulse) to the zero flow rate signal level.

**External automatic zero adjustment input**

Adjust zero.

**External range switching input**

Switches two flow measurement ranges.

**Two flow measurement ranges:**

Dual range for nominal direction.

Normal/reverse range

**Built-in counter reset input**

Resets the totalized value in the built-in counter.

**Contact output function****Alarm output**

Outputs an alarm under the following conditions.

- Self-diagnostic result
- Empty pipe detection
- High/low limit alarm

**Range switching output**

Outputs the status of flow range.

- Large/small in the dual range
- Normal/reverse

**Counter preset status output**

Activates when the counter reaches the preset value.

**Self-diagnostic result output**

Activates only when a critical failure appears by the self-diagnostic.

**Empty detection output**

Activates only when empty status (when electrodes are in contact with air) is detected.

Please make sure that there is no air trap inside of the detector and process fluid conductivity should be 30 mS/cm or greater for functioning properly.

**High/low limit alarm output**

Activates when a high/low limit occurs.

**Two-stage flow rate alarm output (with two contact outputs)**

Activates when the first high/low limit alarm (H/L) occurs and the second high/low limit alarm (HH/LL) occurs.

**Detectors coupled with MGG14C converter**

MGG14C works with the following Yamatake detectors.

Integral style:

MGG11/18D, MGG11/18F, MGG11/18U, MGS11/28U,

Remote style:

MGG11/18D, MGG11/18F, MGG11/18U, MGG12/19D, MGG12/19F, MGG12/19U, MGS11/28U, MGG15D, MGG15F, KID15B, KID20B, KID30B, KID10B, KID11B, KID12B, NNK140, NNM (some types are not compatible.)

**Optional specifications****Display (optional): LCD with backlighting****Main display**

7-segment, 6 digits

**Sub display**

16 digits, two lines

**Display**

Flow rate in%, Actual flow rate, Totalized value  
Configuration parameters, Self-diagnostic, Write protect status

Main display is selectable among “flow rate in%”, “actual flow rate” and “totalized value”.

**Data setting device**

Configuration by infrared ray touch sensor

Infrared ray touch sensor: Four switches

Write protect: Write protection level is set by switches in the converter.

Write protect level is indicated on the display.

**Empty pipe detection**

When the detector is empty, the analog output, digital output and pulse output are fixed at zero.

Display is latched to zero.

**Traceability certificate**

The following three documents are provided.

- Traceability system chart
- Traceability certificate
- Calibration certificate

**Tag number on the terminal box**

The designated tag numbers (maximum 16 characters) should be stamped on a tag plate, which is attached to the terminal box. One line can contain 8 characters. Tag numbers exceed 8 characters will be stamped on the two lines.

**PERFORMANCE SPECIFICATION****Measurable process fluid conductivity**

It depends on the cable length between the converter and the detector.

With the detector size of 2.5 to 1100mm (0.1 to 44 inch)

3  $\mu$ S/cm or greater

**Accuracy (coupled with MGG, MGS and KID90 type detectors)**

**Table 1**

in combination with a detector

<Size 2.5 to 15 mm (0.1 to 1/2 inch)>

Vs = Velocity of setting range

Vs (m/s)	Velocity during measurement $\geq$ Vs $\times$ 40%	Velocity during measurement $\leq$ Vs $\times$ 40%
$1.0 \leq Vs \leq 10$	$\pm 0.5\%$ of rate	$\pm 0.2\%$ of Vs
$0.1 \leq Vs \leq 1.0$	$\pm(0.1/Vs+0.4)\%$ of rate	$\pm 0.4(0.1/Vs+0.4)\%$ of Vs

<Size 25 to 600 mm (1 to 24 inches)>

Vs = Velocity of setting range

Vs (m/s)	Velocity during measurement $\geq$ Vs $\times$ 20%	Velocity during measurement $\leq$ Vs $\times$ 20%
$1.0 \leq Vs \leq 10$	$\pm 0.5\%$ of rate	$\pm 0.1\%$ of Vs
$0.1 \leq Vs \leq 1.0$	$\pm(0.1/Vs+0.4)\%$ of rate	$\pm 0.2(0.1/Vs+0.4)\%$ of Vs

<Size 700 to 1100 mm (28 to 44 inches)>

Vs = Velocity of setting range

Vs (m/s)	Velocity during measurement $\geq$ Vs $\times$ 50%	Velocity during measurement $\leq$ Vs $\times$ 50%
$1.0 \leq Vs \leq 10$	$\pm 1.0\%$ of rate	$\pm 0.5\%$ of Vs
$0.1 \leq Vs \leq 1.0$	$\pm(0.2/Vs+0.8)\%$ of rate	$(0.2/Vs+0.8)\%$ of Vs

**Magnetic field effect**

$\pm 0.2\%$ FS max. (400A/m)

**Output Fluctuation**

Range set as  $1 \leq Vs \leq 10$ m/s:  $\pm 0.1\%$ FS max.

Range set as  $0.1 \leq Vs \leq 1$ m/s:  $\pm 0.1/Vs\%$ FS max.

(Damping: 3seconds, with clean water (150 $\mu$ S/cm))

**PHYSICAL SPECIFICATION****Housing and cover material**

Aluminum alloy (ADC12)

**Glass**

Tempered glass (thickness 5mm (0.2inch))

**Name plate material**

SUS304 (thickness 0.5mm (0.02inch))

**Screw material**

SUS304

**Gasket material between housing and cover**

EPDM

**Paint**

Standard: baked acrylic resin

Corrosion-proof: Epoxy resin

**Color**

Cover: light beige (Munsell 4Y7.2/1.3)

Housing: dark beige (Munsell 10YR4.7/0/5)

**INSTALLATION SPECIFICATION****Ambient temperature**

-25 to +60 degree C (-13 to 140 degree F)

**Ambient humidity**

5 to 100%RH (no condensation)

**Vibration**

Integral style: 500Hz max. 4.9m/S<sup>2</sup> (0.5G) (16.076 ft/S<sup>2</sup>) max.

Remote style: 500Hz max., 19.6m/S<sup>2</sup> (2G) (64.304 ft/S<sup>2</sup>) max.

**Conduit connection**

G1/2 (PF1/2) internal thread, 1/2NPT internal thread, CM20 internal thread, pg13.5 internal thread

**Mounting**

Remote style: Wall mounting, 2-inch pipe mounting

Integral style: Mount on the detector

**Grounding**

Grounding resistance: 100Ω max.

**Weight**

3.1kg (6.83 lb)

**Site selection**

When selecting an installation site for the flowmeter, observe the following safety measures:

- Do not install the flowmeter near high-current power lines, motors or transformers to prevent damage from electromagnetic induction, which can cause equipment malfunction or output errors.
- Do not use the flowmeter to ground a welder. It can damage the flowmeter.
- Be sure to ground the welding power transformer when welding near the flowmeter to avoid output errors.
- Avoid locations subject to severe vibration or highly corrosive atmospheres to prevent detector breakage or equipment damage.
- Do not install the flowmeter in a location subject to direct sunlight, wind and rain. The converter and detector can be damaged.

**MODEL SELECTION**

**MagneW3000 PLUS<sup>+</sup> Smart Converter (Integral style)**

Model MGG14C - I II III IV - V VI VII VIII - / Options (Some options can be selected per each model.)

Basic model no.

Basic model no.		Selections				Optional selections				
MGG14C										
I	Power supply	100 to 120 V AC, 200 to 240V AC, 47 to 63Hz	M							
		24 V DC, noise filter 50 Hz	P							
		24 V DC, noise filter 60 Hz	R							
II	Output signal / Communication	Volume flow 4 to 20mA DC output / with open collector pulse output / with HART communication or without communication	H							
		Volume flow 4 to 20mA DC output / with open collector pulse output / with SFC communication (Note 1)	B							
		Volume flow DE output / with open collector pulse output / without communication (Note 1)	C							
		Fast Response model Volume flow 4 to 20mA DC output / with open collector pulse output /without communication (Note 9)	R							
III	Electrical connection / Watertight gland	G1/2 internal thread / with brass (Ni-plated) watertight gland			2					
		G1/2 internal thread / with plastic watertight gland			3					
		1/2NPT internal thread / without watertight gland (Note 2)			4					
		CM20 internal thread / without watertight gland			5					
		Pg13.5 internal thread / without watertight gland			6					
		G1/2 internal thread / with SUS304 watertight gland			7					
IV	Installation / Wiring direction	Horizontal piping mounting / upstream side				A				
		Horizontal piping mounting / downstream side				B				
		Horizontal piping mounting / left side viewed from upstream				C				
		Horizontal piping mounting / right side viewed from upstream				D				
		Vertical piping mounting / downstream side (flow direction: downstream to upstream)				E				
		Vertical piping mounting / (flow direction: downstream to upstream)				T				
V	Finish	Corrosion-resistant finish					1			
		Corrosion-proof finish (Note 7)					2			
VI	Display with data setting device	None						X		
		Main display: instantaneous flow rate in %						A		
		Main display: instantaneous actual flow rate							B	
		Main display: indication of totalized value							C	
VII	Contact inputs / outputs	1 input and 1 output (ranging function, warning for contact input/output, etc.)							1	
		2 inputs (ranging function, external automatic zero adjustment input, etc.)								2
		2 outputs (ranging function, warning for contact outputs.)								3
VIII	Style code	None							X	
		FM/CSA NI approval (Note 3)								N

Options	None	X
	Empty pipe detection function	A
	Traceability certificate for converter	C
	Plastic (Polycarbonate) window	G
	Indication other than SI units (Note 6)	H
	Attachment of the TAG number to the terminal box for converter (Note 4)	J
	Specific color paint (Note 5)	L

- Note) 1. External DC power supply is necessary on analog 4-20 mA output. No analog output is expected without the external DC Power supply.  
 2. Must be selected for FM / CSA NI approval.  
 3. For FM/CSA NI, the Electrical connection / watertight gland selection code must be "4".  
 4. Must be selected for Tag no. requirement.  
 5. Must specify Munsell No.  
 6. Must be specified for non-SI unit indication.  
 7. If no display is selected, configuration should be done by HART or SFC communicator.  
 8. When process fluid level in the flowtube is under electrodes, this function is activated and display and output are latched to zero.  
 9. Applicable detector size is from 15mm to 80mm.

**MagneW3000 PLUS<sup>+</sup> Smart Converter (Remote style)**

Model MGG14C - I II III IV - V VI VII VIII - Options (Some options can be selected per each model.)

Basic model no.

		Selections			Optional selections		
MGG14C							
I	Power supply	100 to 120 V AC, 200 to 240V AC, 47 to 63Hz	M				
		24 V DC, noise filter 50 Hz	P				
		24 V DC, noise filter 60 Hz	R				
II	Output signal / Communication	Volume flow 4 to 20mA DC output / with open collector pulse output / with HART communication or without communication	H				
		Volume flow 4 to 20mA DC output / with open collector pulse output / with SFC communication (Note 1)	B				
		Volume flow DE output / with open collector pulse output / without communication (Note 1)	C				
		Fast Response model Volume flow 4 to 20mA DC output / with open collector pulse output /without communication (Note 9)	R				
III	Electrical connection / Watertight gland	G1/2 internal thread / with brass (Ni-plated) watertight gland	2				
		G1/2 internal thread / with plastic watertight gland	3				
		1/2NPT internal thread / without watertight gland (Note 2)	4				
		CM20 internal thread / without watertight gland	5				
		Pg13.5 internal thread / without watertight gland	6				
		G1/2 internal thread / with SUS304 watertight gland	7				
IV	Installation / Wiring direction	Wall mounting with standard bracket	G				
		2-inch pipe mounting with standard bracket	H				
		Wall mounting with SUS304 bracket	J				
		2-inch pipe mounting with SUS304 bracket	K				
V	Finish	Corrosion-resistant finish	1				
		Corrosion-proof finish	2				
VI	Display with data setting device	None (Note 7)	X				
		Main display: instantaneous indication of flow rate in %	A				
		Main display: instantaneous indication of actual flow rate	B				
		Main display: indication of totalized value	C				
VII	Contact inputs / outputs	1 input and 1 output (ranging function, warning for contact input/output, etc.)	1				
		2 inputs (ranging function, external automatic zero adjustment input, etc.)	2				
		2 outputs (ranging function, warning for contact outputs.)	3				
VIII	Style code	None	X				
		FM/CSA NI approval (Note 3)	N				

Options	Installation / Wiring direction	
	None	X
	Empty pipe detection function (Note 8)	A
	Traceability certificate for converter	C
	Plastic (Polycarbonate) window	G
	Indication other than SI units (Note 6)	H
	Attachment of the TAG number to the terminal box for converter (Note 4)	J
	Specific color paint (Note 5)	L

Installation / Wiring direction

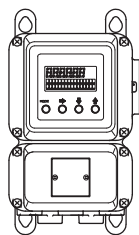

G,J

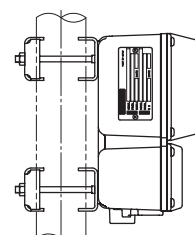

H,K

- Note)
- External DC power supply is necessary on analog 4-20 mA output. No analog output is expected without the external DC Power supply.
  - Must be selected for FM / CSA NI approval.
  - For FM/CSA NI, the Electrical connection/watertight gland selection code must be "4".
  - Must be selected for Tag no. requirement
  - Must specify Munsell No.
  - Must be specified for non-SI unit indication.
  - If no display is selected, configuration should be done by HART or SFC communicator.
  - When process fluid level in the flowtube is under electrodes, this function is activated and display and output are latched to zero.
  - Applicable detector size is from 15mm to 80mm.

**MOUNTING / WIRING DIRECTION**

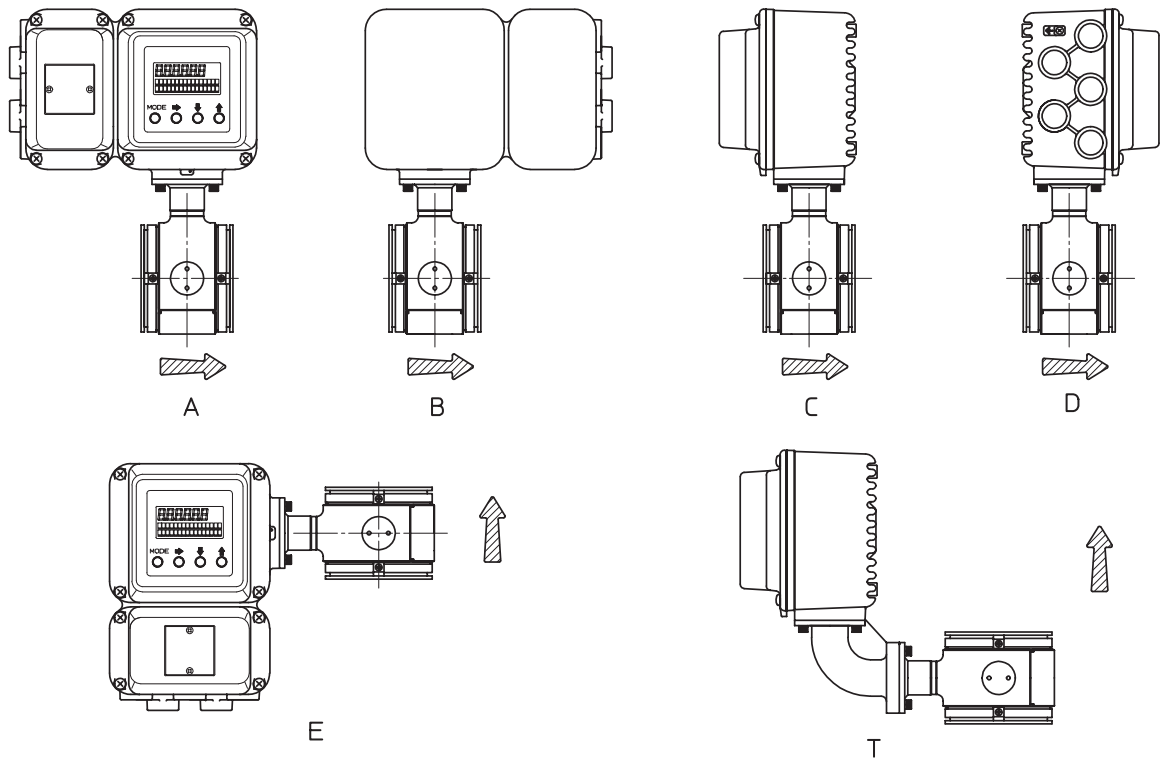

**CONDUIT CONNECTION / WATERTIGHT GLAND**

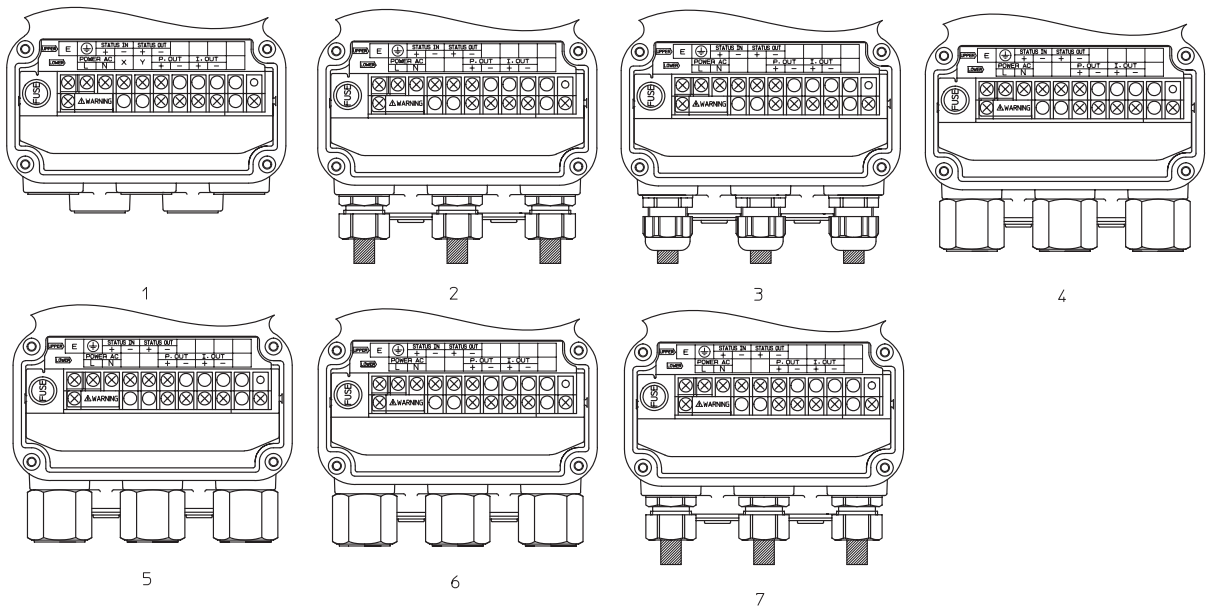

## CONVERTER TERMINAL DESCRIPTION

Table 2 Remote converter terminal descriptions

(1-contact output / 1-contact input)		(2-contact inputs)		(2-contact outputs)	
Symbol	Description	Symbol	Description	Symbol	Description
A	Flow signal input from detector	A	Flow signal input from detector	A	Flow signal input from detector
B					
C					
SA					
SB					
I. OUT	+ -	Analog output	I. OUT	+ -	Analog output
P. OUT	+ -	Pulse output	P. OUT	+ -	Pulse output
X		Excitation output	X		Excitation output
Y					
STATUS OUT	+ -	Contact output	STATUS IN 2	+ -	Contact input 2
STATUS IN	+ -	Contact input	STATUS IN 1	+ -	Contact input 1
POWER AC	L N	Power supply	POWER AC	L N	Power supply
E		Not used	E		Not used
⊥	Grounding (grounding resistance must be < 100 Ω)	⊥	Grounding (grounding resistance must be < 100 Ω)	⊥	Grounding (grounding resistance must be < 100 Ω)

Note)

## CONDUIT CONNECTION / WATERTIGHT GLAND

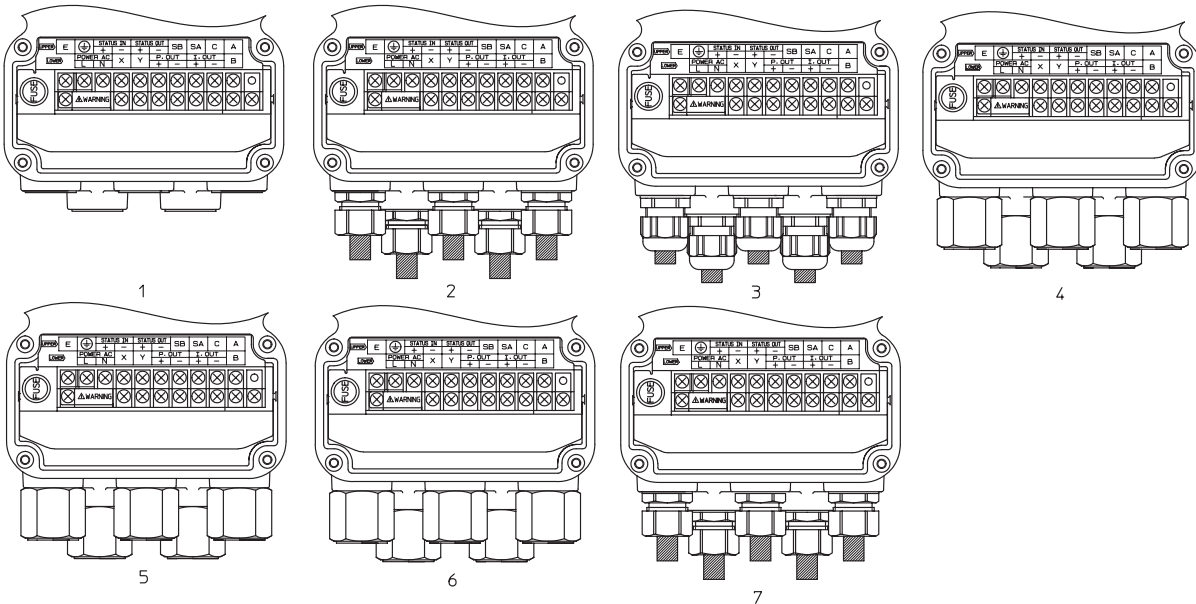

**Dimension drawings**

[Unit: mm]

**Wall mounting**

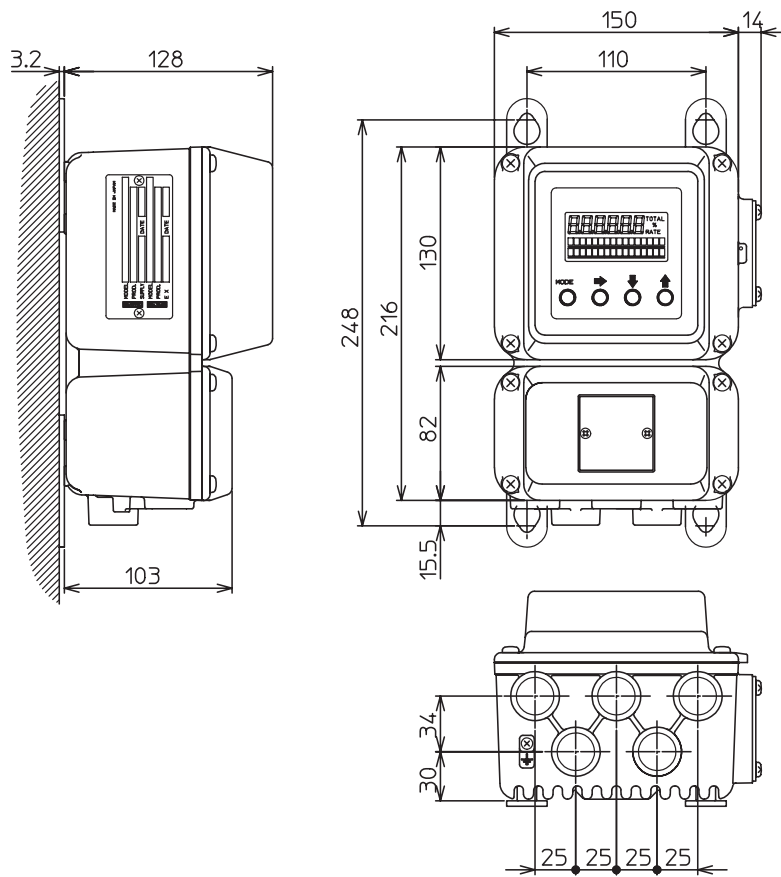

**2 inch pipe mounting**

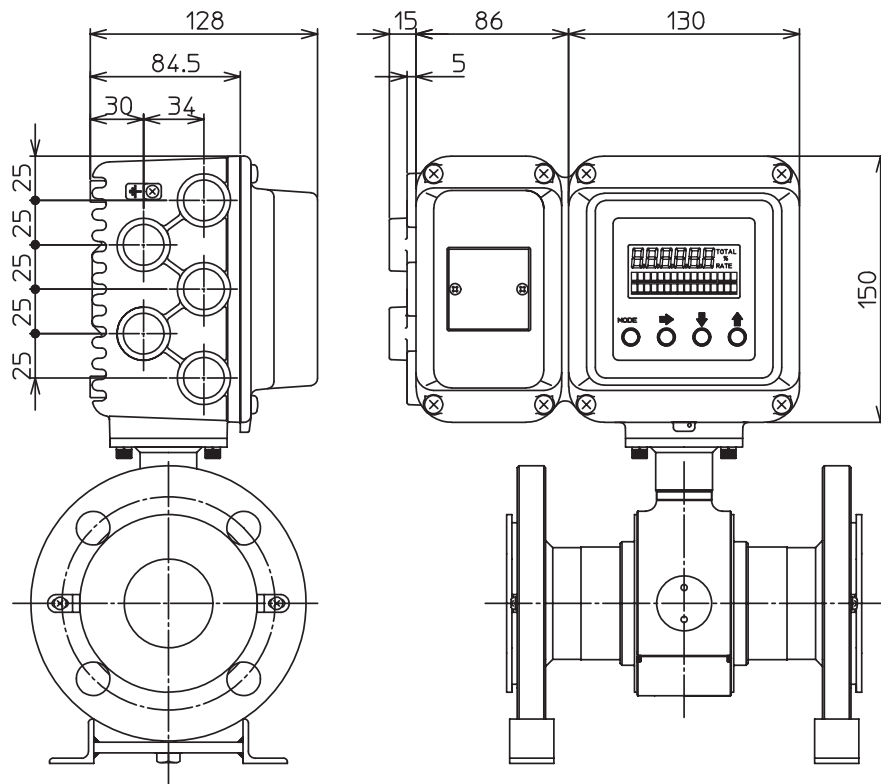

## Integral type

[Unit: mm]

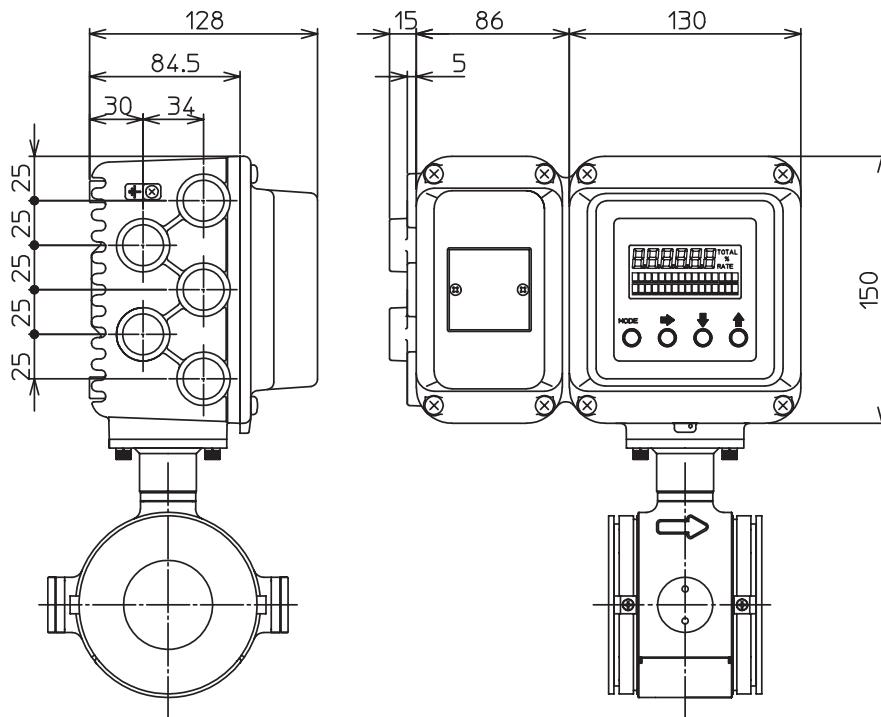

## Flange type

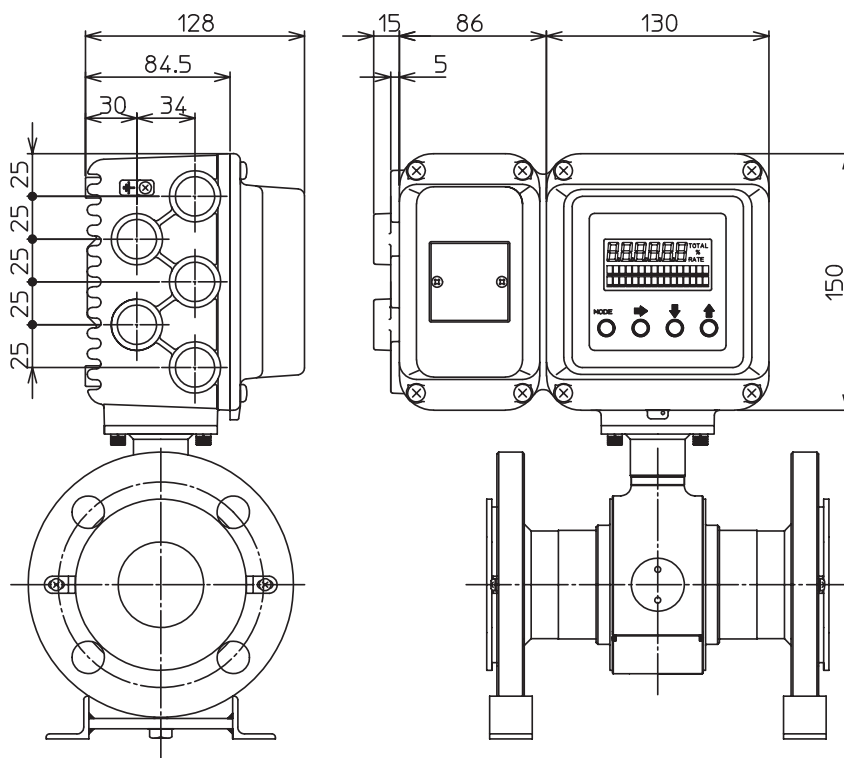

Specifications are subject to change without notice.

**azbil**

**Yamatake Corporation**  
**Advanced Automation Company**

1-12-2 Kawana, Fujisawa-shi  
Kanagawa-ken 251-8522 Japan

URL: <http://www.azbil.com>

No part of this publication may be reproduced or duplicated without the prior written permission of Yamatake Corporation.

July 2007-Y/Y  
Aug. 2008 (rev.4)-Y/Y