

MagneW3000 FLEX
Smart Electromagnetic
Flowmeter
General Use Converter
Model MGG10C
User's Manual

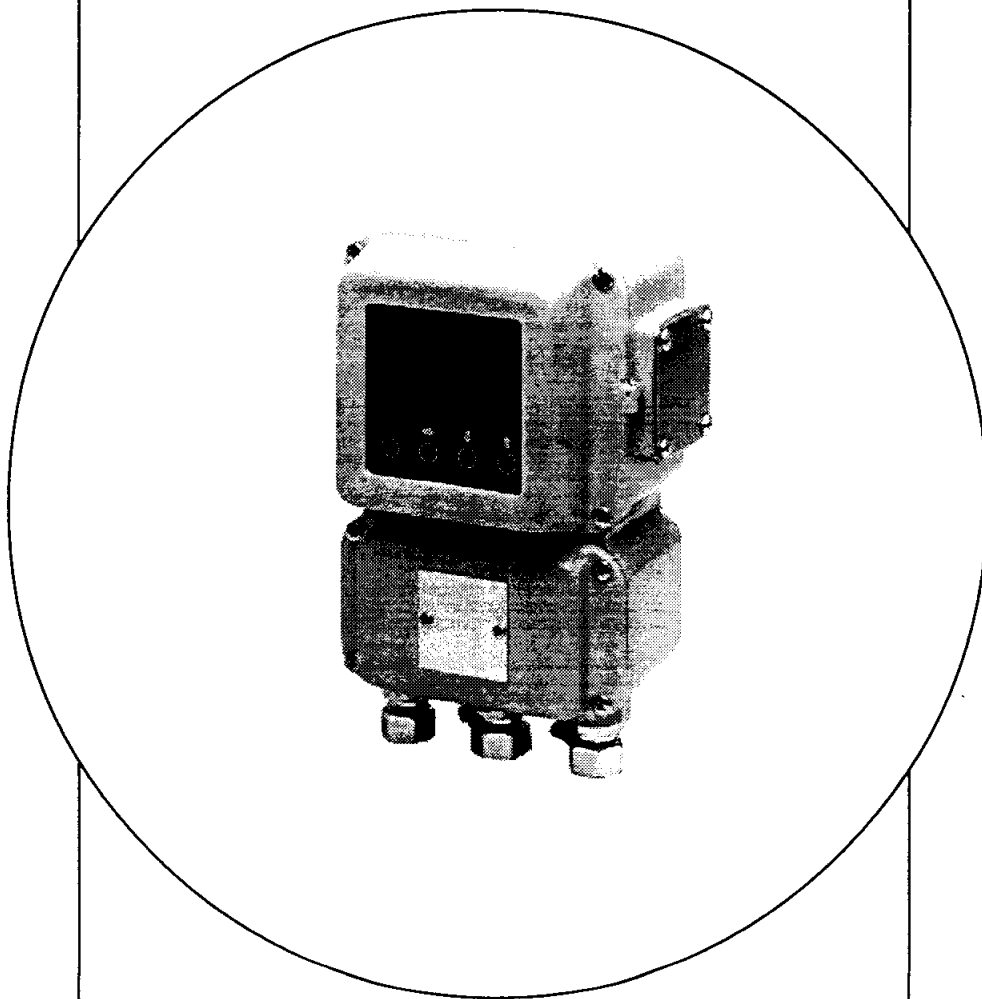

Yamatake Corporation

MagneW3000 FLEX Model MGG10C

ZIMTAKE

Copyright, Notices and Trademarks

Printed in Japan -© Copyright 1998 by Yamatake Corporation

While this information is presented in good faith and believed to be accurate, Yamatake Corporation disclaims the implied warranties of merchantability and fitness for a particular purpose and makes no express warranties except as may be stated in its written agreement with and for its customer.

In no event is Yamatake Corporation liable to anyone for any indirect, special or consequential damages, The information and specifications in this document are subject to change without notice.

MagneW3000 is a trademark of Yamatake Corporation.

Preface

Thank you for purchasing the Yamatake Corporation MagneW 3000 FLEX Smart Electromagnetic Flowmeter. This product is a highly reliable, high performance electromagnetic flowmeter converter for general use. It has been developed based on our extensive experience and field record. This converter suits a wide range of application and is easy to use in on-site operation.

Unpacking and Inspecting Your Product

Unpacking the product

This device is a precision instrument and should be handled with care to prevent damage or breakage.

After unpacking the device, verify that the following items are included:

- The converter itself
 - Standard accessories
 - MagneW Setting Data Sheet
 - Test report
-

Verifying the specifications

The specifications of this device are written on its attached identification plate. Compare these specifications with those listed in the Appendix, "System Standard Specifications and Model Numbers," and verify that all specifications on the plate are correct, paying special attention to the following:

- Basic model number
 - Power supply
 - Output/communications
 - Contact input/output
-

Inquiries

If you have any questions regarding the specifications of this device, contact your nearest Yamatake Corporation office or Yamatake Corporation representative. When making an inquiry, make sure to provide the model number and product number of this device.

Storage precautions

When storing this device before use, observe these precautions:

- Store it indoors at room temperature and humidity, in a place safe from vibration or shock.
- Store it in the same condition as it was shipped.

When storing this device after use, follow these steps:

1. Attach the display cover, the terminal box cover, and the water-proof gland to keep out moisture.
 2. Replace the product in its original packaging.
 3. Store it indoors at normal temperature and humidity and in a place safe from vibration or shock.
-

Safety Precautions

Introduction

Correct installation, correct operation and regular maintenance are essential to ensure safety when using this device. Don't use the system, before reading and understanding the safety precautions described in this manual and be sure to follow the instructions on installation, operation and maintenance.

Signal words

Two kinds of safety precaution are used in this manual —Warning and Caution. The meaning of these is as follows:



Potentially hazardous situation which, if not avoided, could result in death or serious injury.



Failure to observe these precautions may produce dangerous conditions that could result in injury to the user or in physical damage.

How this Manual is Organized and Used

Organization and Method of Use

This user's manual explains the use of the system and its associated devices in the following order:

Chapter 1

This chapter explains the configuration of measuring systems based on this product, the structure of this product and the Smart Communicator (S-SFC), and the names and functions of their respective parts.

Chapter 2

This chapter explains the installation and wiring of the system. Persons in charge of the installation of this unit, the piping installation, and the wiring should refer to this chapter.

Chapter 3

This chapter explains the procedures for starting-up, operating, and stopping this product. *Two operating methods are explained; one uses the data setting device of this product and the other uses the Smart Communicator (S-SFC).* Read this chapter when using this product just after installation or after the operation of this product has been halted.

Chapter 4

This chapter explains the operation of this product using the data setting device.

Chapter 5

This chapter describes the procedures to be followed for maintenance and checking of this unit and for troubleshooting. Refer to this chapter when performing maintenance and troubleshooting.

Appendixes A to B

These appendixes describe the specifications of this product and the S-SFC, the measuring principle of this product, and the model number organization.

Refer to the appendixes to check these items.

Detailed Table of Contents

Chapter 1 -	Configuration and Structure of the Measuring Systems	1 - 1
	Outline of this chapter	1 - 1
1.1	System Configuration	1 - 2
	Measuring System	1 - 2
	Analog Output and Digital Output	1 - 4
	System Configuration for Analog Output (4 - 20 mA DC output)	1 - 5
	System Configuration for Digital Output (DE Output)	1 - 8
1.2	Structure of this Unit and Functions of Parts	1 - 9
	Structure of the Device	1 - 9
Chapter 2 -	Installing the Device	2 - 1
	Outline of this chapter	2 - 1
2.1	Before Installation	2 - 2
	Selecting the Installation Site (1)	2 - 2
2.2	Installation Method	2 - 3
	Installing the Converter	2 - 3
	Electrical Wiring (1)	2 - 5
	Electrical Wiring (2)	2 - 8
	Electrical Wiring (3)	2 - 11
	Electrical Wiring (4)	2 - 12
	Electrical Wiring (5)	2 - 13
	Electrical Wiring (6)	2 - 14
	Electrical Wiring (7)	2 - 15
Chapter 3 -	Operating and Stopping of the Measuring System	3 - 1
	Outline of this chapter	3 - 1
3.1	Start-up	3 - 2
3.2	Preparations before Measurement	3 - 3
	Zero Adjustment (1)	3 - 3
	Method Using the Data Setting Device	3 - 4
	Method Using the S-SFC	3 - 6
3.3	Stopping	3 - 7
3.4	Setting the Communication Function	3 - 8
3.5	Setting Write Protection	3 - 10
3.6	Setting the Empty Detection Function	3 - 11
Chapter 4 -	Operation Using the Data Setting Device	4 - 1
	Outline of this chapter	4 - 1
4.1	Functions of the Data Setting Device	4 - 2
	Data Setting Device	4 - 2
	Operating the Display/Data Setting Device	4 - 5
	Screen Organization	4 - 7
	How to Skillfully Operate the Touch Key Switches	4 - 10
	How to Enter the Operator's Mode	4 - 11
	Operating in Operator's Mode	4 - 12
	Resetting the Damping Time Constant	4 - 13
	Zero Adjustment	4 - 14
	Setting the Reset Value of the Built-in Flow Counter	4 - 16

Resetting the Built-in Flow Counter	4 - 17
Setting/Changing the Preset Value of the Built-in Flow Counter	4 - 18
Setting/Changing the Flow Rate Indication	4 - 19
Selecting Modes	4 - 20
Engineering Mode	4 - 22
Setting the ID	4 - 24
Selecting Functions	4 - 25
Relations for Setting Function FXXXX	4 - 27
Range Functions	4 - 31
“Built-in Counter Function”	4 - 36
“Contact Input Function”	4 - 37
“Contact Output Function”	4 - 38
Detector Data Setup	4 - 41
Setting the Number of Dummy Detectors	4 - 43
Setting the Range	4 - 44
Setting Hysteresis	4 - 45
Selecting the Current Output Method	4 - 46
Setting the Specific Gravity	4 - 47
Setting/Changing the Coefficient of Compensation	4 - 48
Setting the Pulse Scale	4 - 49
Setting the Pulse Width	4 - 50
Setting the Drop-out	4 - 51
Setting High and Low Limit Alarms	4 - 52
Setting a 2-stage Flow Rate Alarm	4 - 53
Setting the Low Flow Cut	4 - 55
Determining the Pulse Output Abnormality Treatment Direction	4 - 56
Determining Analog Output Abnormality Treatment Direction	4 - 57
Setting the Contact Output Status	4 - 58
Maintenance Mode	4 - 60

Chapter 5 - Maintenance and Troubleshooting of the Electromagnetic Flowmeter	5 - 1
Outline of this chapter	5 - 1
5.1 Checking Functions	5 - 2
Checking the Input/Output Signal Loop	5 - 2
Checking the Analog Output	5 - 3
Checking the Pulse Output	5 - 4
Checking the Contact Input/Output Loop	5 - 5
Checking the Excitation Current	5 - 7
False Signal Input by Calibrator	5 - 8
5.2 Troubleshooting	5 - 9
Overview	5 - 9
Errors at Start-up	5 - 10
Errors during Operation	5 - 11
Error Messages and Treatment (Display)	5 - 13

Appendix A - Standard Specifications of this Unit and Model Numbers	Appendix A-1
Appendix B - External View of This Unit	Appendix B-1

Figures and Tables

Figure 1-1	Integral configuration	1 - 2
Figure 1-2	Remote configuration	1 - 3
Figure 1-3	System configuration for analog output WITHOUT communication function	1 - 6
Figure 1-4	System configuration for analog output WITH the communication function (example setup)	1 - 7
Figure 1-5	System configuration for digital output	1 - 8
Figure 1-6	Structure of the main body	1 - 9
Figure 2-1	Wall mounted	2 - 3
Figure 2-2	2B pipe mounted	2 - 3
Figure 2-3	Integral assembly	2 - 4
Figure 2-4	Terminal arrangement for remote converter	2 - 6
Figure 2-5	Relation between fluid conductivity and cable length	2 - 8
Figure 2-6	Outer Dimensions of Signal Cables	2 - 9
Figure 2-7	Signal Cable Construction	2 - 9
Figure 2-8	Outer Dimensions of Excitation Cables	2 - 10
Figure 2-9	Excitation Cable Construction	2 - 10
Figure 2-10	Detector-to-converter connection	2 - 11
Figure 2-11	Wiring diagram for current output	2 - 13
Figure 2-12	Wiring diagram for pulse output	2 - 14
Figure 2-13	Wiring diagram for contact input	2 - 15
Figure 2-14	Wiring diagram for contact output	2 - 15
Figure 4-1	Names of data setter parts	4 - 2
Figure 4-2	Normal direction automatic double range	4 - 32
Figure 4-3	Normal/reverse automatic switching range	4 - 34
Table 4-1	Converter and detector combinations	4 - 42

Chapter 1 - Configuration and Structure of the Measuring System

Outline of this chapter

This chapter explains the configuration of measuring systems using this unit.

- The structure of this unit and the names and functions of its respective parts are explained.
 - The smart communicator (S-SFC) required for communication with this unit is explained.
-

1.1 System Configuration

Measuring System

Introduction

Depending on the way it is combined with the detector, this product is available in two configurations; integral and remote.

- Integral: detector and converter are installed as an integrated unit on the pipe.
- Remote: detector and converter are installed separately and connected by a cable.

Examples of flow measurement systems

Figures 1-1 and 1-2 show examples of measurement systems using the device.

Figure 1-1 Integral configuration

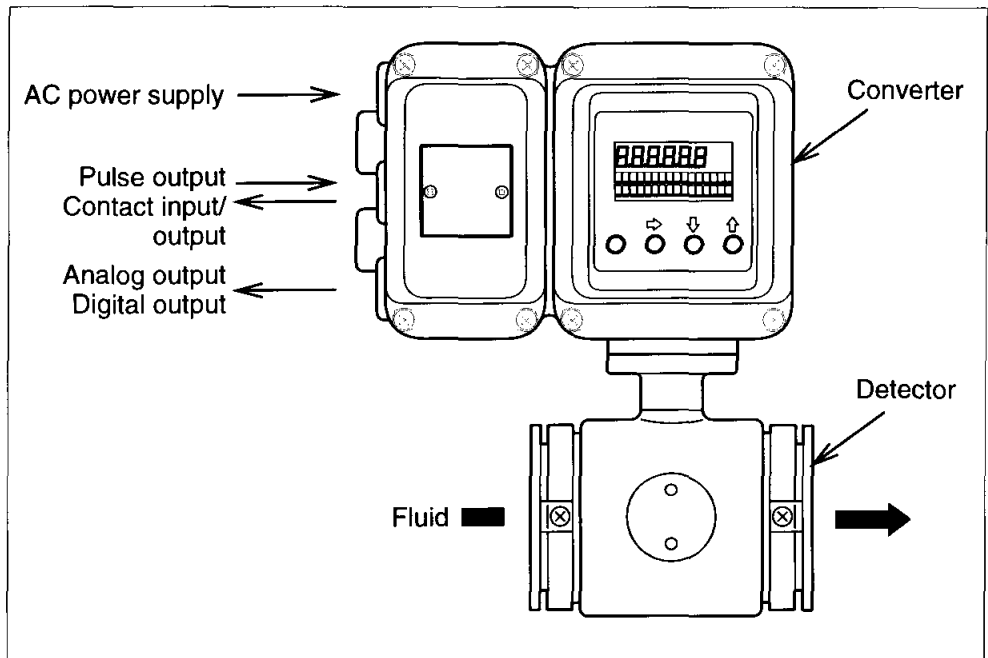

(Continued on next page)

Measuring System Continued

Examples of flow measurement systems (Continued)

Figure 1-2 Remote configuration

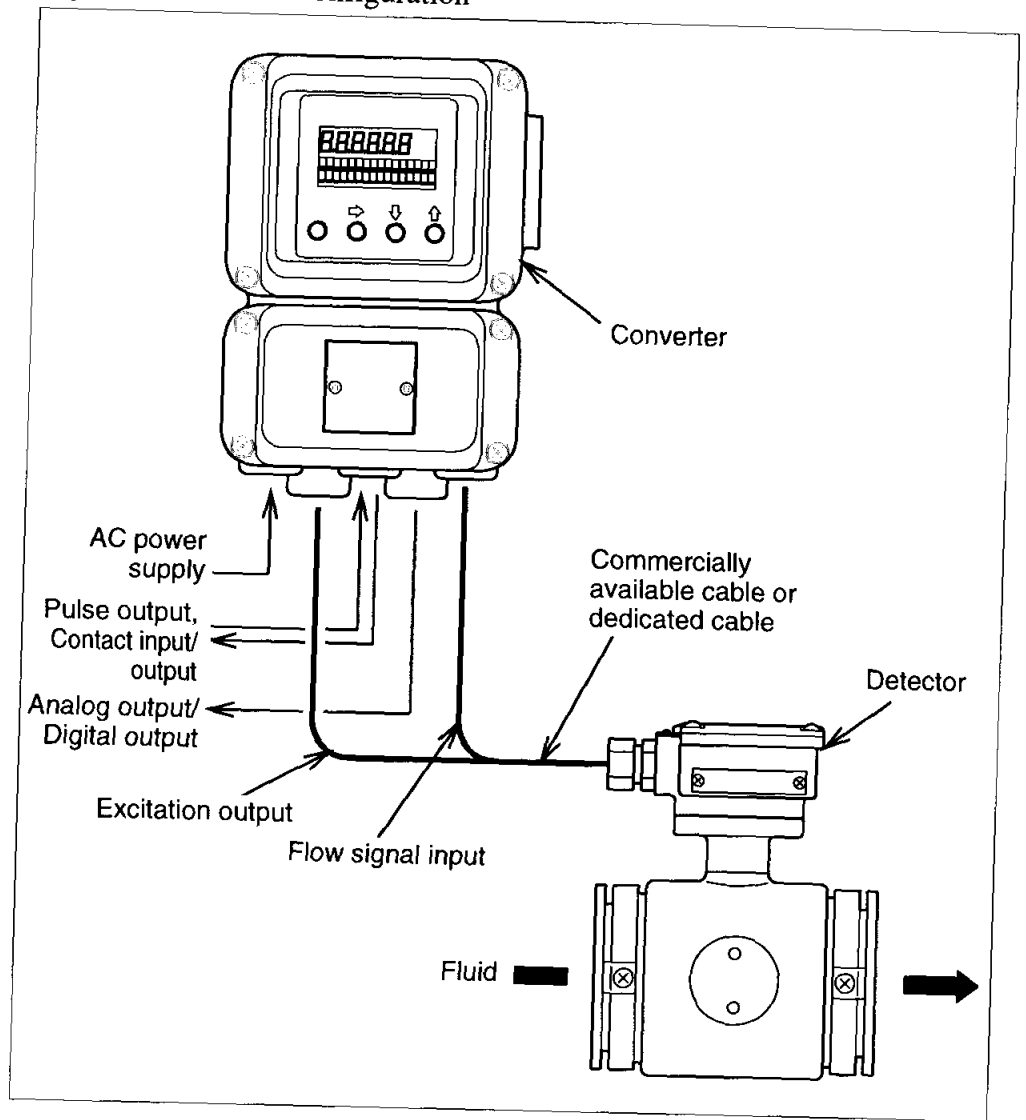

Analog Output and Digital Output

Introduction The configuration chosen depends on the purpose: systems with an analog signal output and systems with a digital signal output. Different equipment will be required depending on the output required.

**Analog output
(4 - 20 mA DC output)** An analog output system outputs only the instantaneous flow rate as an analog value to the control equipment.

**Digital output
(DE output)** A digital output system outputs the instantaneous flow rate, the database in the unit, and self-diagnosis to the control equipment.

Switching output The output for this unit can be selected. Refer to the "selective specifications" in the model number organization. Additionally, output can be changed on-site using the smart communicator (S-SFC).

System Configuration for Analog Output (4 - 20 mA DC output)

Introduction

The choice of analog output depends on the purpose: WITH or WITHOUT the communication function. Different equipment will be required depending on the output style chosen.

WITHOUT the communication function

The DC power supply that transmits the analog output is built into the product.

Analog output range is 0.8 mA - 22.4 mA (-20% - +115%).

Resistive load is 0 - 600Ω.

WITH the communication function

Install on the receiving side the external power supply (DC power with a current capacity of at least 40 mA) and the external resistive load (min. 250 Ω required for communication).

Analog output range is 3.2 mA - 22.4 mA (-5% - +115%).

The DC power is 16 - 45 V DC, and the maximum value of the external resistive load is:

$$\text{Maximum resistive load } (\Omega) = \frac{\text{External power supply for communication} - 8.5\text{V}}{0.025}$$

Note:

- For systems WITH the communication function, failure to install the external power supply and the external resistive load, will prevent the analog output from being accepted on the receiving instrument side. Be sure to install the external power supply and the external resistive load as specified.
-

Continued on next page

System Configuration for Analog Output (4 - 20 mA DC output)

continued

System configuration WITHOUT the communication function

Figure 1-3 shows a sample system configuration in which the instantaneous flow rate measured by the unit is output with a 4 - 20 mA DC analog signal. In this system, the DC power supply that transmits the analog signal is integrated into the unit, which can output the analog signal directly to the host control system.

Figure 1-3 System configuration of analog output WITHOUT communication function

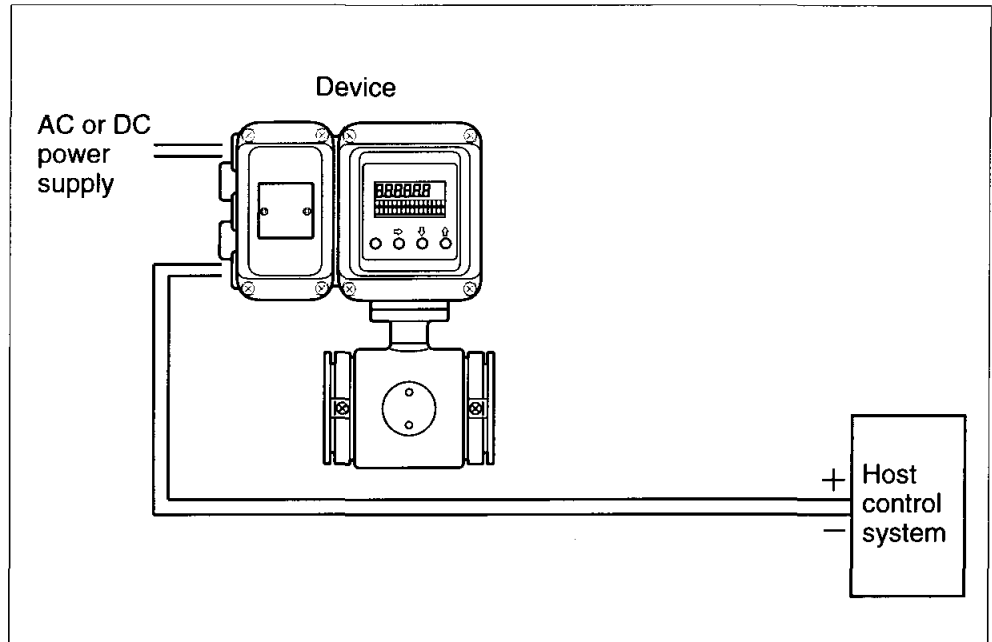

- Smart Electromagnetic Flowmeter (device): Measures flow rate and outputs an analog signal instantaneous flow rate.

Continued on next page

System Configuration for Analog Output (4 - 20 mA DC output)

continued

System configuration WITH the communication function

Figure 1-4 shows a sample system configuration in which the instantaneous flow rate measured by the unit is output with a 4 - 20 mA DC analog signal. In order to enable communications, a DC power supply and a resistance of 250Ω or more must be installed on the receiving side.

Figure 1-4 System configuration for analog output WITH the communication function (example setup)

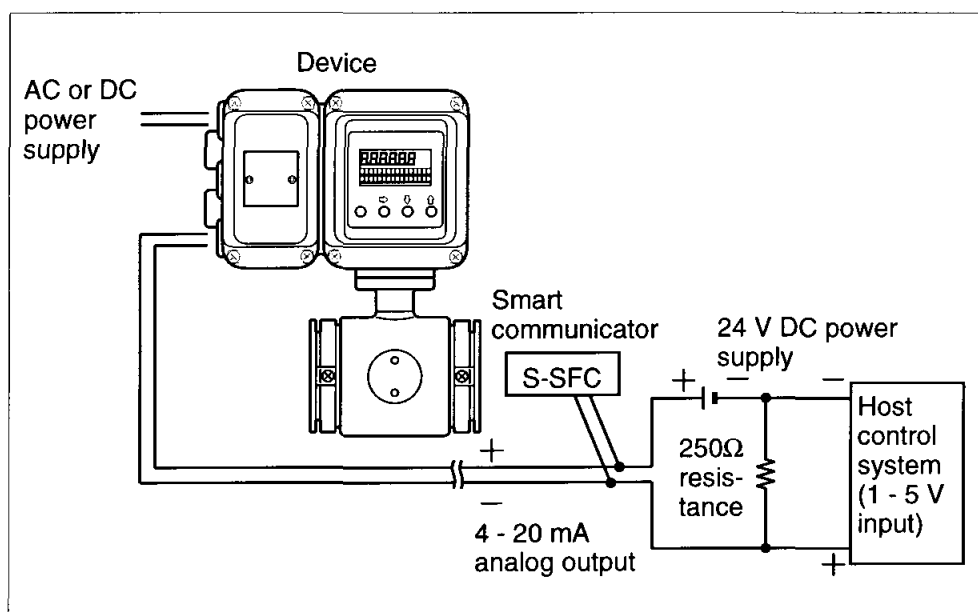

- Smart Electromagnetic Flowmeter (device): Measures flow rate and outputs an analog signal instantaneous flow rate.
- Smart Communicator (S-SFC): Communicates with the device to read data and change the device settings.

System Configuration for Digital Output (DE Output)

System configuration

Figure 1-5 shows a system configuration in which the flow rate measured by the unit, the database in the unit, and self-diagnostics are output using the DE (Digital Enhancement) protocol (rules for digital signal communication).

In this system, the DE protocol-based digital signal transmitted from the unit is output to the control system after conversion to an analog signal at the smart protocol converter (SPC). Or, the digital signal is directly transmitted to the control system, if it is capable of receiving the DE protocol-based signal directly.

Figure 1-5 System configuration for digital output

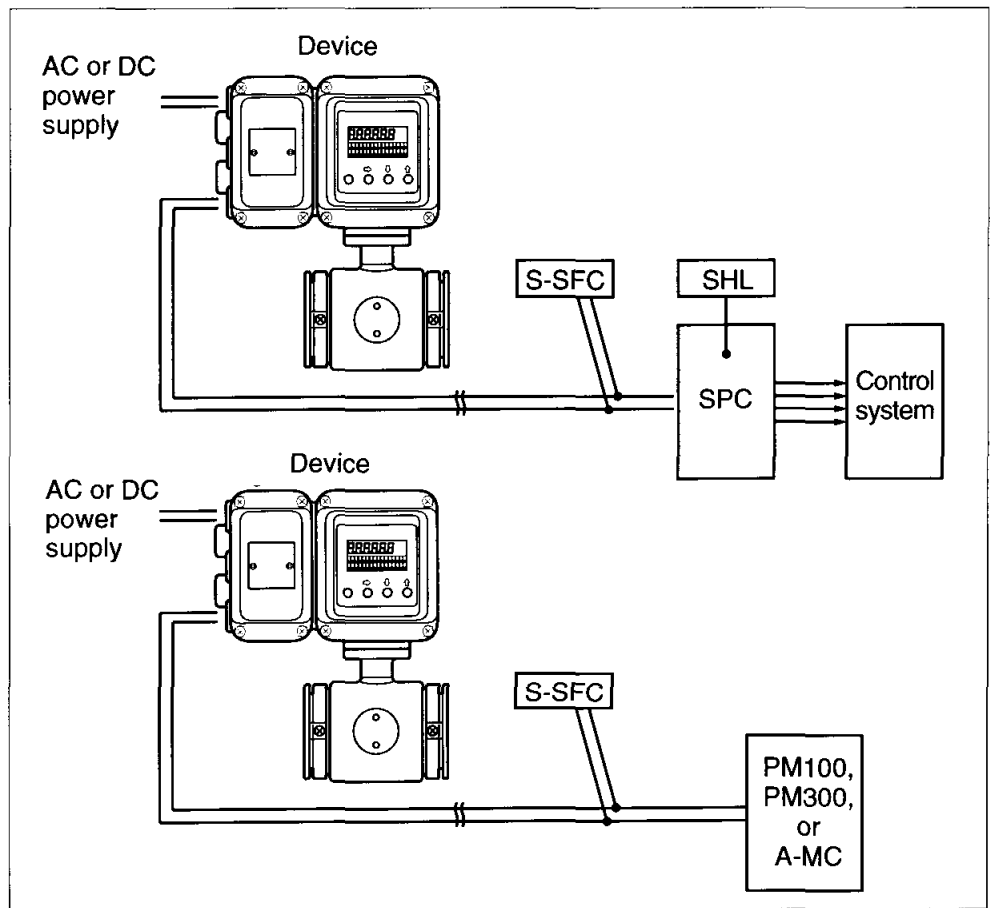

- Smart electromagnetic flowmeter (device): Measures the flow rate and outputs the instantaneous flow rate and unit self-diagnostics using a digital signal.
- Smart protocol converter (SPC): Converts the DE protocol-based digital signal into a 4 - 20 mA or 1 - 5 V DC analog signal for output.
- Smart handy loader (SHL): Used to change the SPC settings.
- Smart communicator (S-SFC): Used to communicate with the device to read data and change the device settings.
- PM100: Simultaneously executes such functions as process control on the UCN, regulatory control, sequencing, calculation, and process input/output.

1.2 Structure of this Unit and Functions of Parts

Structure of the Device

Main components

This unit consists of the converter main body, the contact I/O card, pulse card, data setting device, and a terminal box.

Figure 1-6 Structure of the main body

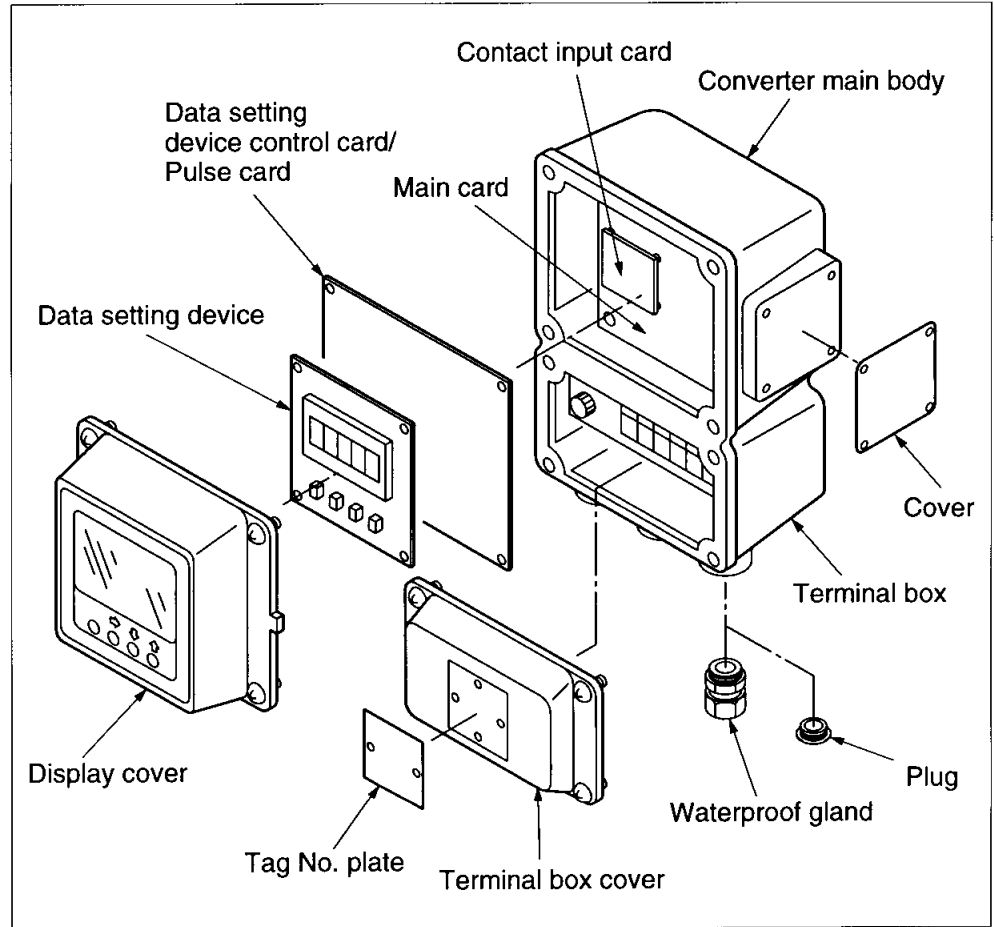

Continued on next page

Structure of the Device Continued

Converter parts and explanation

The following table explains the various parts.

Name	Explanation
Converter main body	<ul style="list-style-type: none">• Converts signal electromotive force generated in the detector into the instantaneous flow rate.• Outputs the instantaneous flow rate to the control equipment as an analog or digital signal.
Data setting device	<ul style="list-style-type: none">• Indicates the instantaneous flow rate or the <i>integrated flow rate</i>.• The flowmeter functions can be changed using the four keys on the panel.
Terminal box	<ul style="list-style-type: none">• Encloses the input/output terminals.• Contains an integrated 12 kV, 100 A isolator.
Nameplate	<ul style="list-style-type: none">• Indicates model number, the product number, and the detector constant (EX) .
Tag No. plate	<ul style="list-style-type: none">• Indicates tag number as specified in the product order.

Chapter 2 - Installing the Device

Outline of this chapter

This chapter explains the installation and wiring procedures of the device in the following order.

- Selecting the installation site
 - Adjusting the data setting device direction
 - Installing the device
 - Signal line wiring
-

2.1 Before Installation

Selecting the Installation Site (1)

Introduction

In order to make full use of the device functions, please observe the following criteria when selecting an installation site.

Notes :

- Install the product in a location with an ambient temperature of -25°C - $+60^{\circ}\text{C}$ and an ambient humidity of 5 - 100% RH to prevent equipment malfunction or output errors.
 - *Avoid installing the product near high-current power lines, motors, or transformers to prevent damage from electromagnetic induction, which may cause equipment malfunction or output errors.*
 - **DO NOT** use this product for grounding a welder, as it may cause damage to the product.
 - When welding near this product, be sure to ground the welding power transformer.
 - Avoid locations subject to severe vibration or highly corrosive atmospheres to prevent detector breakage or equipment damage.
 - Keep the product away from direct sunlight, wind, and rain to prevent output errors.
-

2.2 Installation Method

Installing the Converter

Basic installation method Installation

There are three ways to install the converter: integral converters are assembled with the detector; remote detectors can be wall mounted, or mounted on a 2B converters are assembled pipe.

Figure 2-1 Wall-mounted

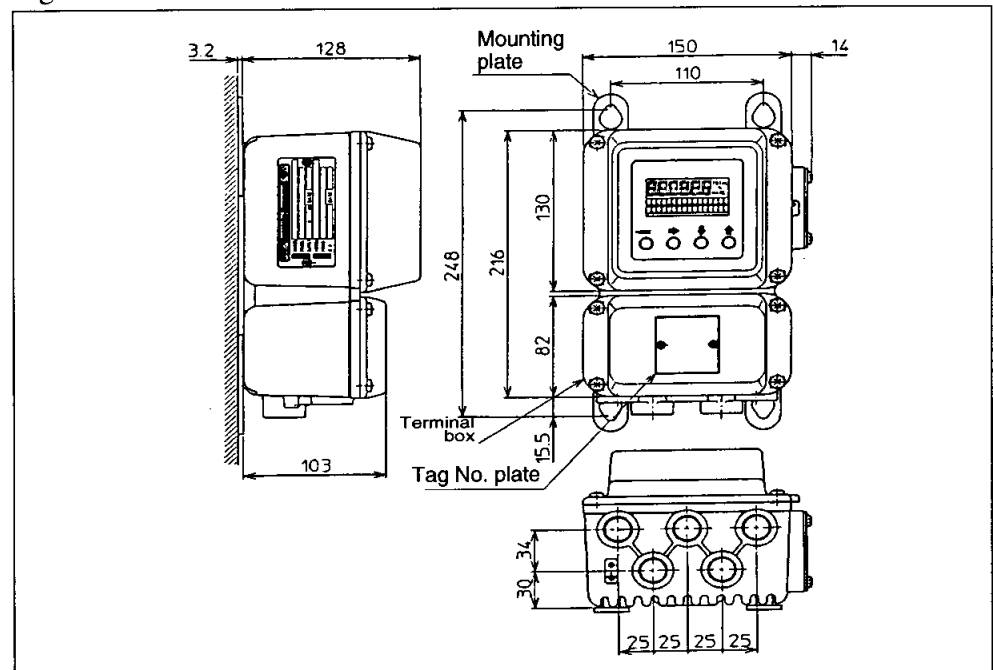
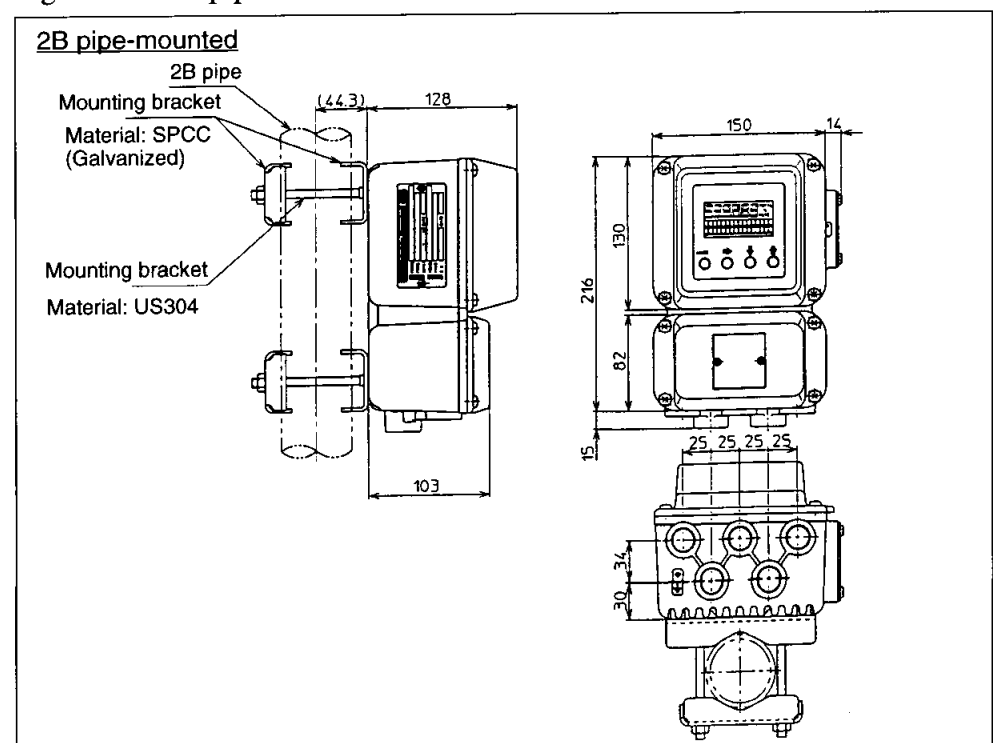

Figure 2-2 2B pipe-mounted



(Continued on next page)

Installing the Converter Continued

**Basic installation
method
Installation
(continued)**

Figure 2-3 Integral assembly

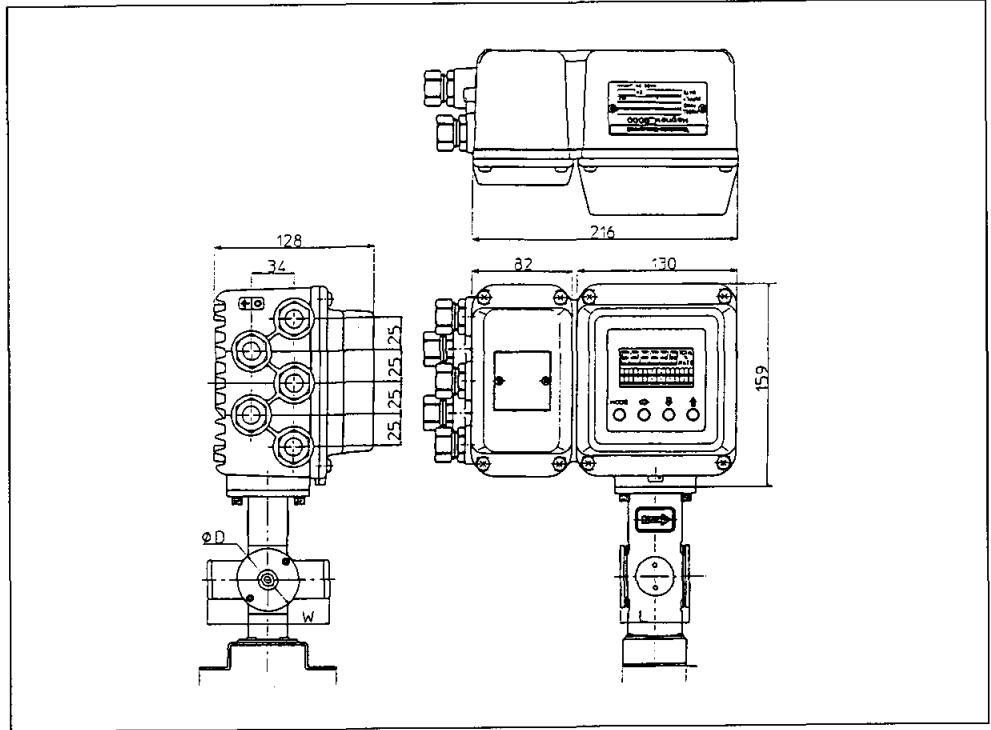

Electrical Wiring (1)

Introduction

A commercial power supply or DC 24 V \pm 10% power supply is used. The following electrical wiring considerations are explained here.

- Cable connection positions
- Power supply and resistive load
- Cable selection and installation
- Grounding
- Wiring procedure

Note :

- This electromagnetic flowmeter is designed for a commercial power supply or 24 V DC power supply. Please confirm the model number on the name plates.
-

Connecting positions for the electromagnetic flowmeter main body

Figure 2-5 (below) shows the terminal block of the electromagnetic flowmeter main body.

 Warning
--

- | |
|---|
| <ul style="list-style-type: none">• During wiring, turn OFF the power supply before opening the cover in order to prevent the danger of electric shock.• DO NOT perform wiring work while the power is ON, as it may result in electric shock. |
|---|

Notes :

- Perform wiring according to the directions in order to prevent equipment damage.
 - Be sure to check the power line wiring positions carefully, as a high-voltage power flow is used.
-

(Continued on next page)

Electrical Wiring (1) Continued

Terminal arrangement

Figure 2-4 Terminal arrangement for remote converter

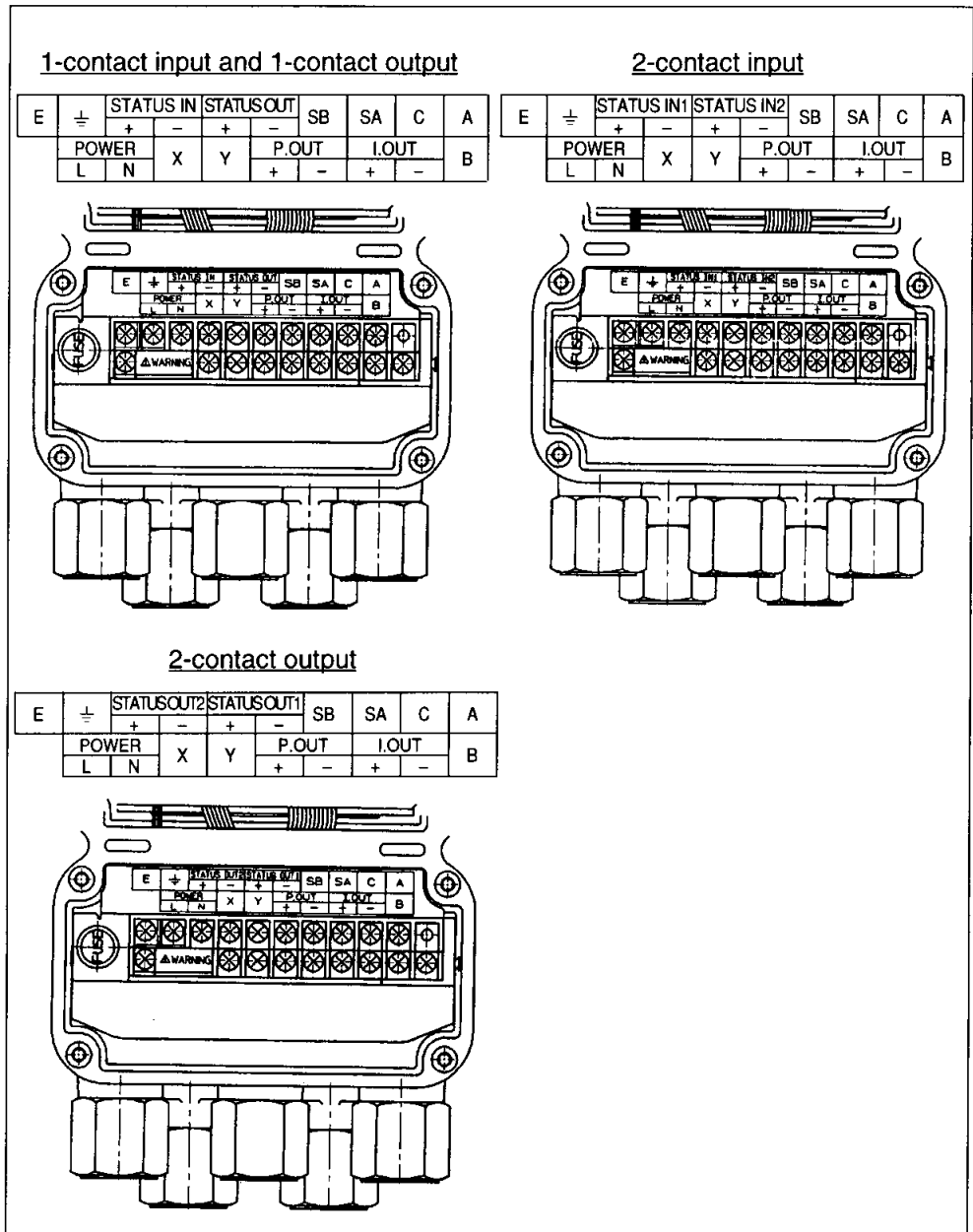

Terminal arrangement for integral converter

On an integral converter, terminal symbols X, Y, SB, SA, A, B, C, and E are not indicated as on the remote converter, because these terminals are not used.

Terminal arrangement of a 24 V DC converter

The 24 V DC converter has a terminal marked "POWER DC24V" instead of "POWER", as on the remote converter. Pay close attention to the "+" and "-" polarity.

(Continued on next page)

Electrical Wiring (1) Continued

Converter terminal tables

Remote converters

1-contact input and 1-contact output

Symbol		Meaning
A		Flow rate signal input
B		
C		
SA		
SB		
I.OUT	+	Current output
	-	
P.OUT	+	Pulse output
	-	
X		Excitation output
Y		
STATUS OUT	+	Contact output
	-	
STATUS IN	+	Contact input
	-	
POWER AC	L	Power supply
	N	
E		Not used
⏏		Class 3 grounding

2-contact input

Symbol		Meaning
A		Flow rate signal input
B		
C		
SA		
SB		
I.OUT	+	Current output
	-	
P.OUT	+	Pulse output
	-	
X		Excitation output
Y		
STATUS IN1	+	Contact input 1
	-	
STATUS IN2	+	Contact input 2
	-	
POWER AC	L	Power supply
	N	
E		Not used
⏏		Class 3 grounding

2-contact output

Symbol		Meaning
A		Flow rate signal input
B		
C		
SA		
SB		
I.OUT	+	Current output
	-	
P.OUT	+	Pulse output
	-	
X		Excitation output
Y		
STATUS OUT2	+	Contact input 2
	-	
STATUS OUT1	+	Contact input 1
	-	
POWER AC	L	Power supply
	N	
E		Not used
⏏		Class 3 grounding

DC24V

1-contact input and 1-contact output

Symbol		Meaning
A		Flow rate signal input
B		
C		
SA		
SB		
I.OUT	+	Current output
	-	
P.OUT	+	Pulse output
	-	
X		Excitation output
Y		
STATUS OUT	+	Contact output
	-	
STATUS IN	+	Contact input
	-	
POWER DC 24V	L	Power supply
	N	
E		Not used
⏏		Class 3 grounding

Electrical Wiring (2)

Cable between detector and converter

Use a dedicated cable (Model: MGA12W) to connect the detector to the converter. The signal cable used may be a dedicated cable made by Yamatake Corporation or a commercially available cable and depends on fluid conductivity, cable length, and the diameter of the detector.

Please refer to the following:

- Dedicated Yamatake Corporation cable usage range: ranges **A** and **B**
- Other cable usage range: **A** only

Figure 2-5 Relation between fluid conductivity and cable length

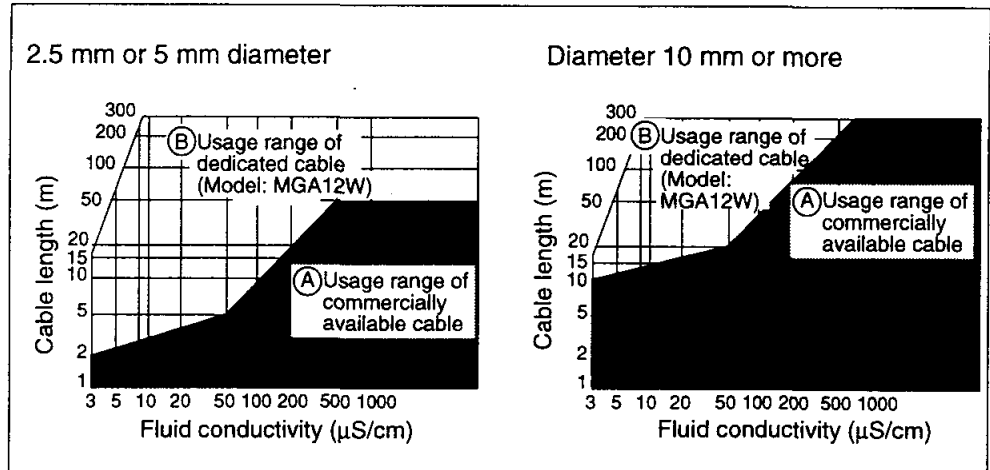

Cable specifications

Cable (between remote detector and converter):

Length: Max. 300 m (Depends on fluid conductivity)

Outer diameter: 10 - 12 mm

Signal cable:

Dedicated cable (Diameter 11.4 mm, 0.75 mm²) or equivalent commercially available cable (e.g. CVVS, CEEV)

Excitation cable:

Dedicated cable (Diameter 10.5 mm, 2 mm²) or equivalent commercially available cable (e.g. CVV)

(Continued on next page)

Electrical Wiring (2) Continued

Signal Cables (Model: MGA 12W)

Figure 2-6 Outer Dimensions of Signal Cables

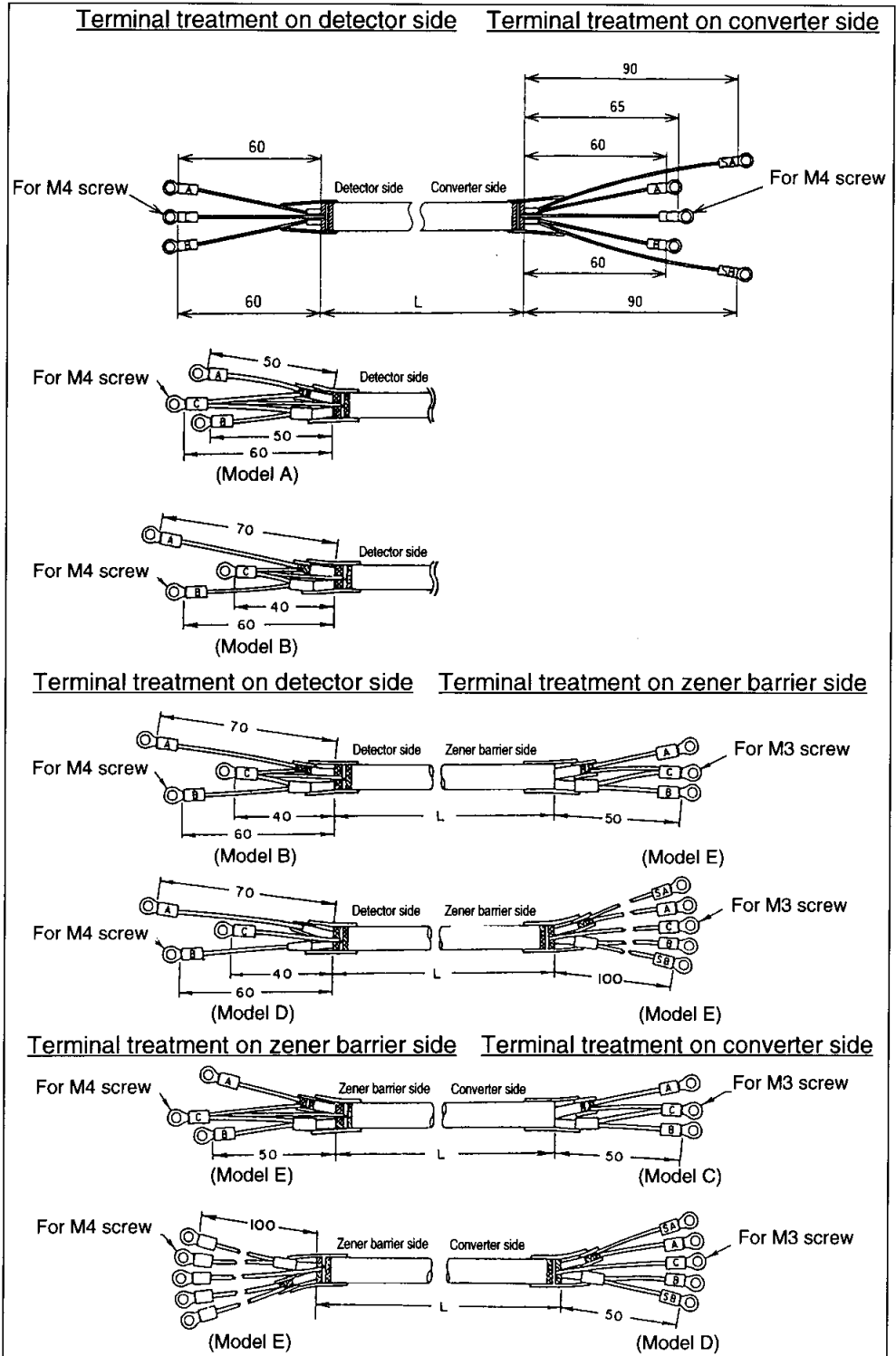
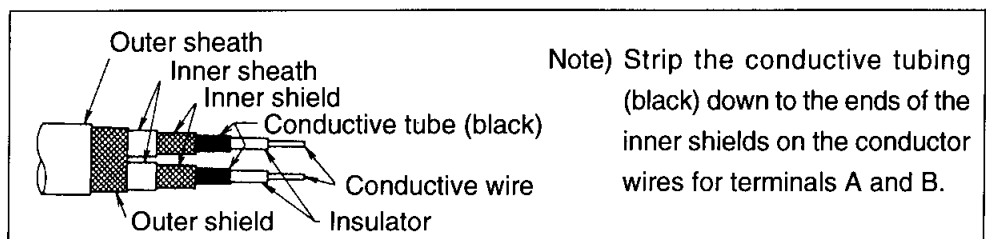

Figure 2-7 Signal Cable Construction



Electrical Wiring (2) Continued

Excitation Cables (Model: MGA 12W)

Figure 2-8 Outer Dimensions of Excitation Cables

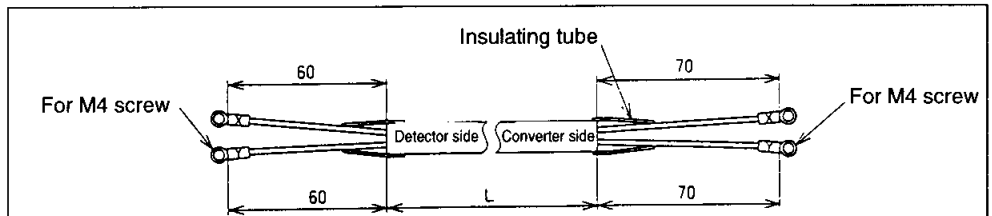

Terminal treatment on detector side

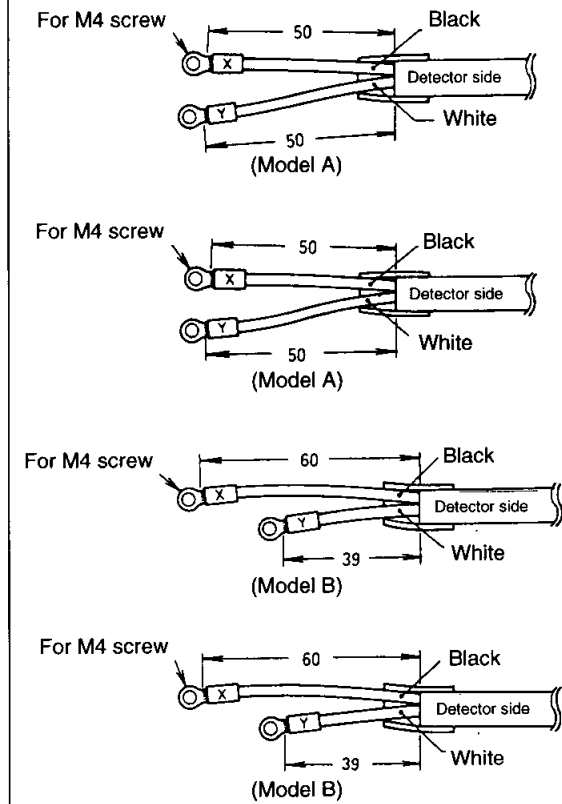
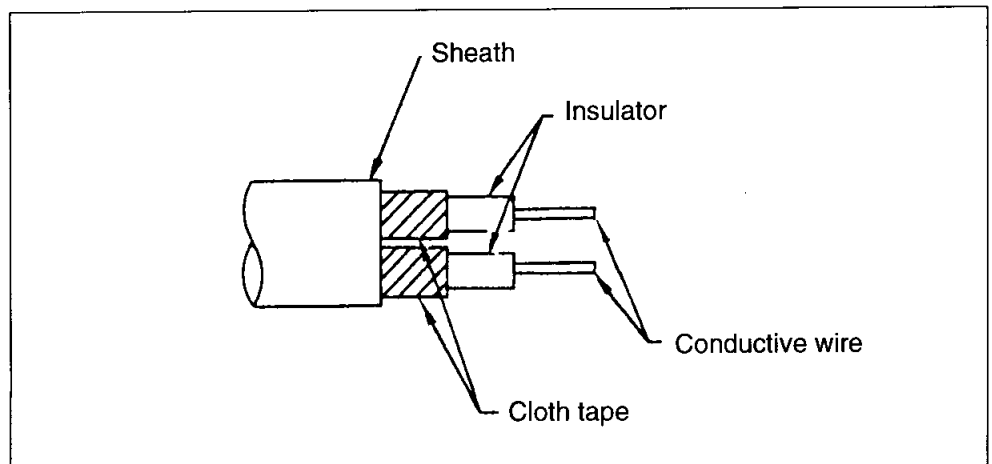

Figure 2-9 Excitation Cable Construction



Electrical Wiring (3)

Detector-to-converter connection

Figure 2-10 Detector-to-converter connection

- Wiring of dedicated cables (Model: MGA12W)

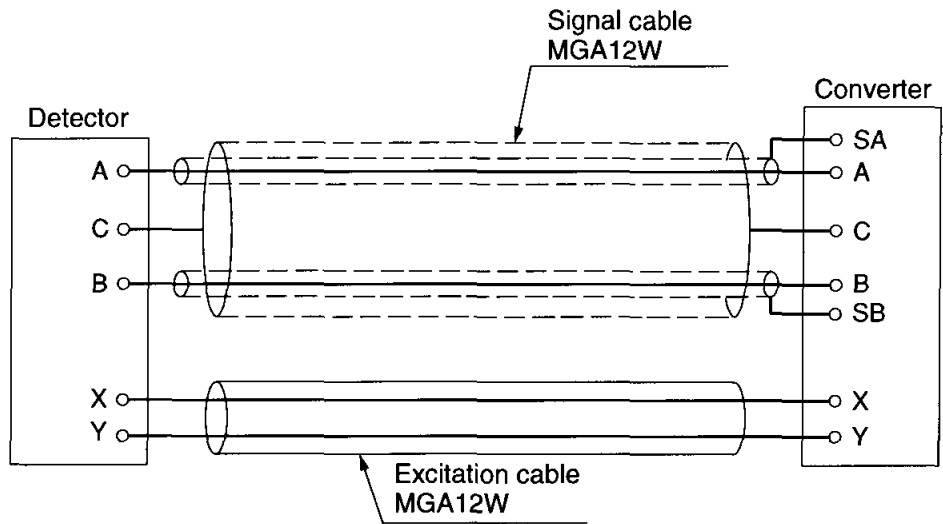

- Commercially available cable

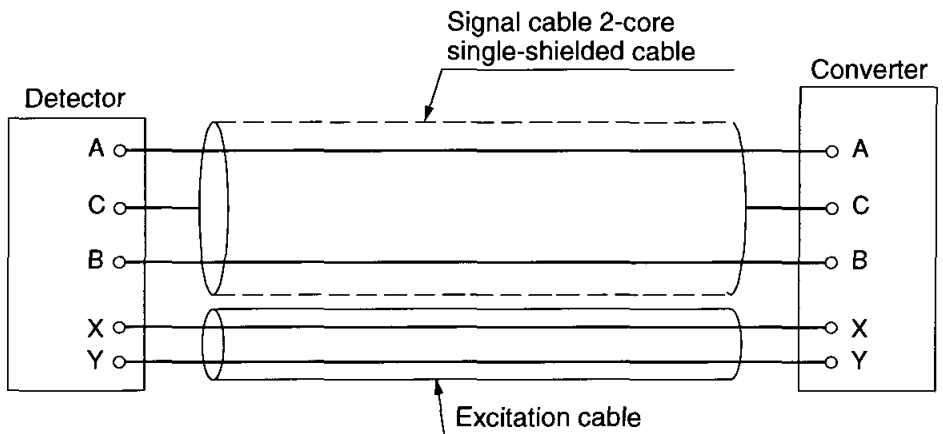

Electrical Wiring (4)

Selecting the wiring cable

The recommended wiring cable is a 600 V vinyl sheath electrical wire CVV (JIS C 3401) with a conductor section of 2 mm², or a twisted cable with an equivalent or higher capacity.

Shielded wire is recommended for wiring at locations subject to electromagnetic noise interference.

Select a sheath material suitable for the cable installation environment (consider ambient temperature, corrosive gas, corrosive fluid, etc.).

Run the cable into the terminal block through the conduit connection (G1/2 internal thread, CM20 external thread, Pg13.5 or 1/2NPT internal thread). An outer diameter of $\phi 11$ is optimum. (The applicable range of cable outer diameters is $\phi 10 - \phi 12$.)

A crimp terminal (M4 screw) with an insulation sleeve is recommended for the terminal connections.

The maximum length of the wiring cable is 1500 m. However, the maximum length between converter and detector is 300 m.

Installing the wiring cable

When installing the cable connecting this product to the control equipment, the following precautions must be observed.

Notes:

- Run the wiring away from equipment that may cause noise, such as high-capacity transformers, motors, or power supplies. DO NOT install the cable in the same tray or duct as other power cables. Output errors may result.
 - Wiring with electrical tube and duct is recommended to keep out water and protect the wire from external damage. Also, be sure to use a waterproof gland at the conduit connection.
-

Electrical Wiring (5)

Current output wiring

The current output wiring method depends on whether or not communication with the S-SFC is used.

An external power supply is required to communicate with the S-SFC.
(Switch the main board pins after turning the power supply OFF.)

Figure 2-11 Wiring diagram for current output

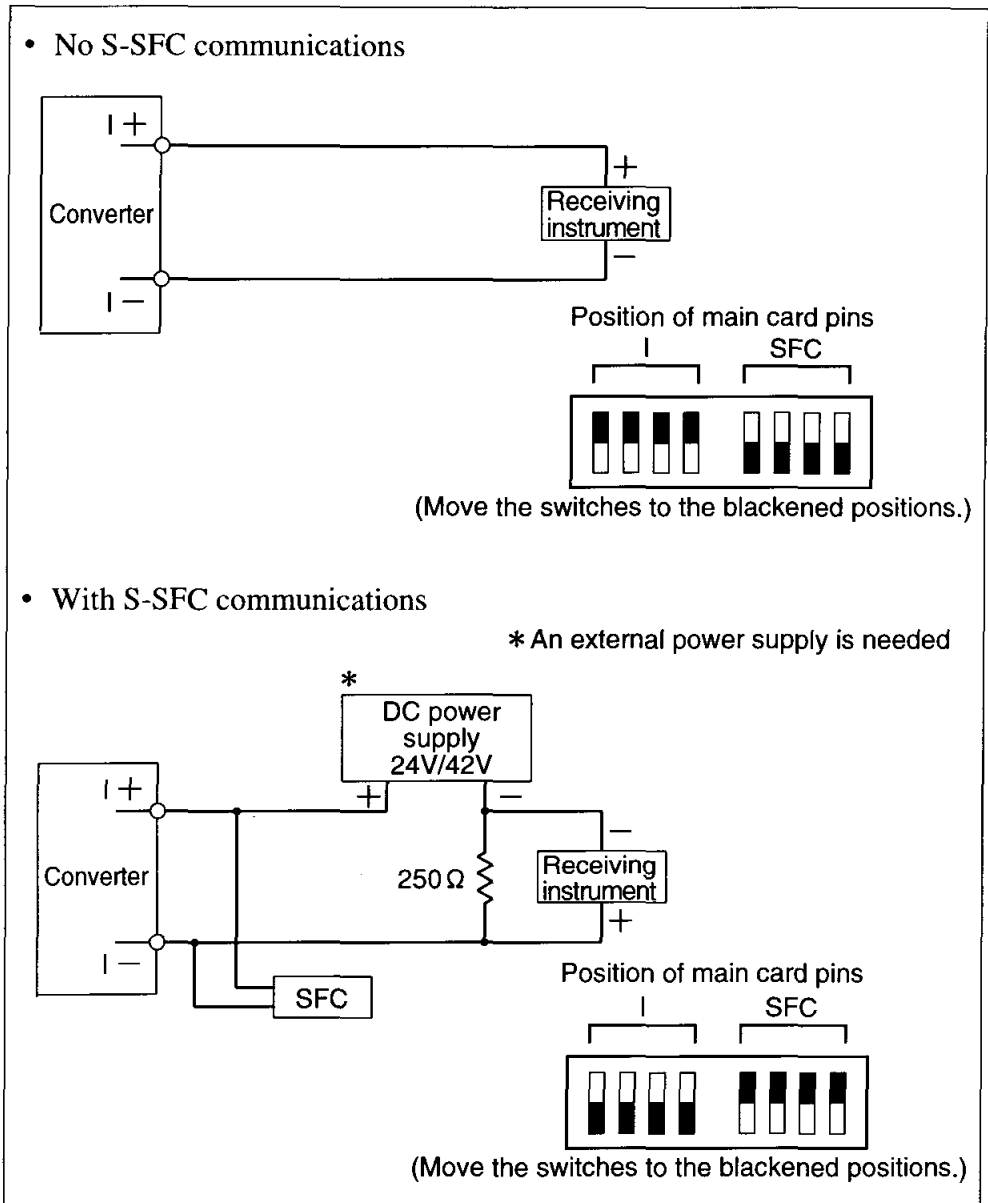

Note:

- Miswiring of polarity may cause damage to the equipment. Recheck the wiring position carefully.

Electrical Wiring (6)

Pulse output wiring

The pulse output is an open collector output.
Pay close attention to voltage and polarity when wiring.

Figure 2-12 Wiring diagram for pulse output

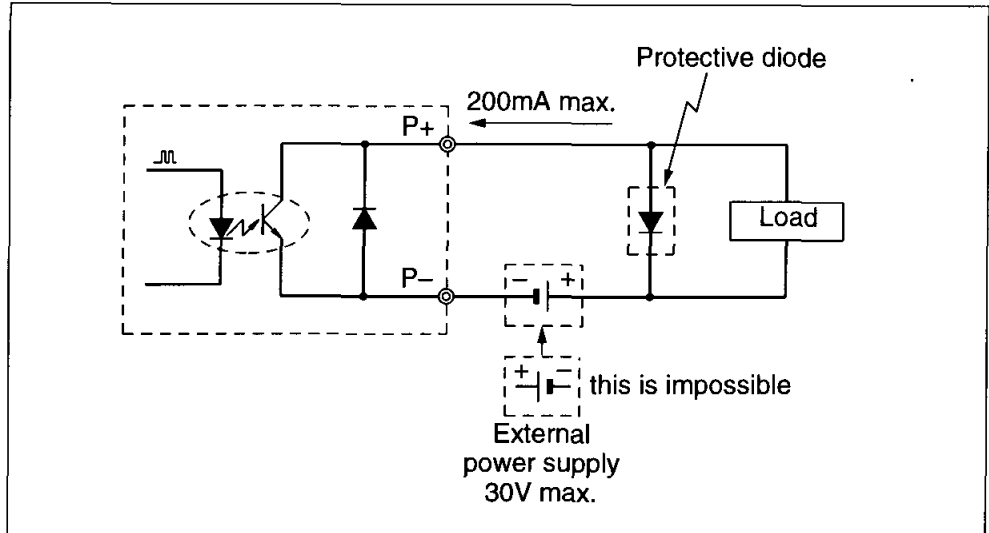

Note:

- Miswiring of polarity may cause damage to the equipment. Recheck the wiring position carefully. Use an external power supply with voltage and capacity that satisfy the specifications.

Electrical Wiring (7)

Contact input wiring

Either a semiconductive contact or a no-voltage contact can be used as the contact input.

The contact input/output terminals are not available when a 2-contact output model has been selected.

Figure 2-13 Wiring diagram for contact input

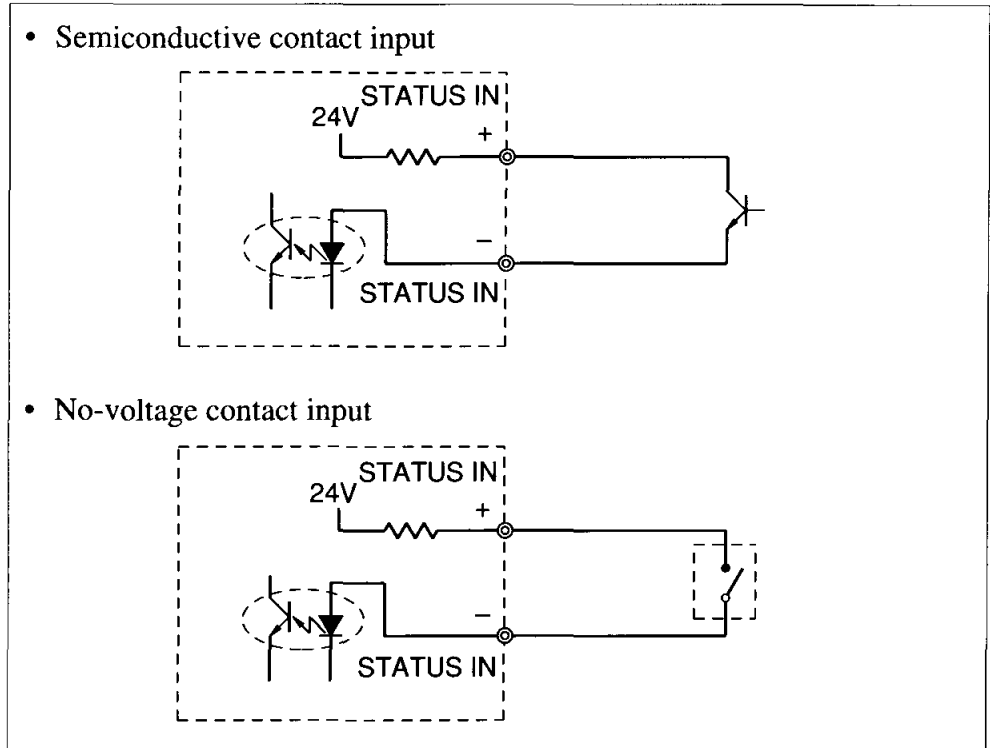

Contact output wiring

Pay close attention to voltage and polarity when wiring, because this is an open collector output.

Figure 2-14 Wiring diagram for contact output

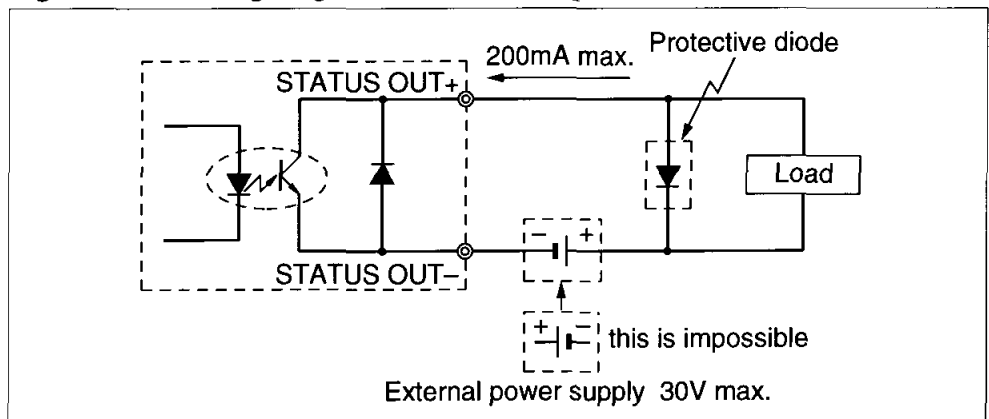

Note:

- Miswiring of polarity may cause damage to the equipment. Recheck wiring position carefully.
- Use an external power supply with voltage and capacity that satisfy the specifications.

MEMO

Chapter 3 - Operating and Stopping of the Measuring System

Outline of this chapter

This chapter explains the procedures for starting up this product and making zero adjustment. It also describes stopping the system.

When starting up and operating this product for the first time, carefully follow the explanation given in this chapter.

Two kinds of zero adjustment are available with this product:

- Using the data setting device that may be included with this product
- Using communications between the S-SFC and this product
(Refer to S-SFC User's Manual CM2-SFC100-2001.)

For an electromagnetic flowmeter with no data setting device, select the method that uses the S-SFC.

Both methods allow zeroing the flowmeter and employ a data setting device.

Before using this product, be sure to perform the following settings as instructed in this chapter.

- Setting the write protect level
 - Setting whether or not communications are used
 - Setting the empty detection function
-

3.1 Start-up

Starting up

Procedures

Start up the electromagnetic flowmeter according to the following steps.

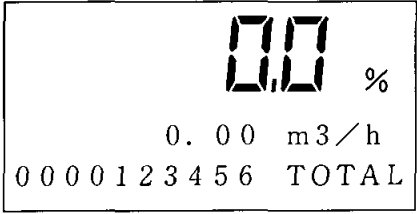
Step	Procedure
1	Make sure the electromagnetic flowmeter detector is properly installed on the pipe.
2	Make sure the wiring between the electromagnetic flowmeter detector and converter has been completed properly. For communication with the S-SFC, make sure the S-SFC wiring has also been properly completed.
3	Charge the electromagnetic flowmeter with the fluid to be measured, and make the fluid stand still.
4	Make sure there is no fluid leaking from the flange to which the electromagnetic flowmeter is attached.
5	Turn the power to the electromagnetic flowmeter ON. <u>Branch:</u> <ul style="list-style-type: none">• For flowmeters without the data setting device, this is the completion of start-up. Next, start up the S-SFC.• For flowmeters with the data setting device, proceed to Step 6.
6	Make a display similar to the one shown below appears on the LCD. <div style="text-align: center;"><p>The LCD display shows a flow rate of 0.00 m³/h and a total volume of 0000123456. The flow rate is displayed as '0.00' followed by a '%' symbol. Below it, '0. 00 m³/h' is shown. At the bottom, the digits '0 0 0 0 1 2 3 4 5 6' are followed by the word 'TOTAL'.</p></div> Start-up of the electromagnetic flowmeter has now been completed.

3.2 Preparations before Measurement

Zero Adjustment

Introduction

After start-up, be sure to zero the electromagnetic flowmeter. There are two zero adjustment methods:

- Using the data setting device for this product
- Using the S-SFC (Refer to S-SFC User's Manual CM2-MGG000-2001 "MagneW 3000 FLEX Smart Electromagnetic Flowmeter S-SFC II User's Manual.")

For electromagnetic flowmeters without the data setting device, select the S-SFC method.

Both methods allow zeroing an electromagnetic flowmeter and employ a data setting device.

Method Using the Data Setting Device

Introduction





Adjust the electromagnetic flowmeter so that the instantaneous flow when the fluid in the detector stands still is measured as zero.

Notes:

- Zero adjustment is very important for accurate flow rate measurement.

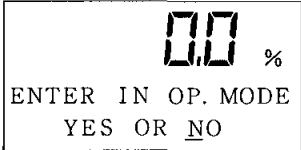
Be sure to zero the flowmeter before it is first operated.

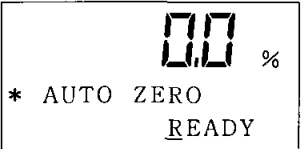

- Before zero adjustment, make sure the detector is correctly Class 3 grounded and that the fluid to be measured has been charged and stands still in the detector. Zero adjustment becomes possible when the flow speed is 0.2 m/s or less, but wait until the fluid completely stops (Flow speed: 0.0 m/s) for accurate adjustment. Otherwise, output errors may result.

Step	Procedure	Screen
1	Touch the MODE key for more than 3 seconds. Note: The screen at left will be displayed for 8 seconds. Complete the following operations within 8 seconds.	
2	Touch the MODE key on the data setting device for more than three second to enter the Operator Mode. Touch the  key to display the screen shown. Note: This is the screen when the main display is set to % units.	
3	Touch the  key once.	

Continued on next page

Method Using the Data Setting Device Continued

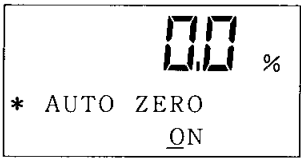
Method using the data setting device
(continued)

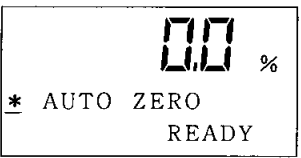
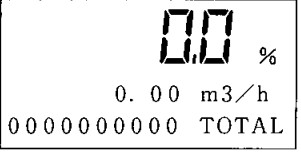
Step	Procedure	Screen
4	Touch the  key to start zero adjustment. During adjustment, when the large 7-segment displays the flow rate in %, "0.0" will be flashing. When zero adjustment is completed, the flashing will stop and the "ON" message will return to "READY". Zero adjustment takes about 30 seconds.	
5	Touch the  key once.	
6	Touch the MODE key for more than three second to return to the Measuring Mode (measuring status). The zero value will be written into non-volatile memory.	
7	Lastly, be sure to end the operation by touching the MODE key.	

Method using the S-SFC

Method using the S-SFC

Perform the following steps.

Step	Procedure	S-SFC screen	
		English	Japanese
1	Make sure the fluid to be measured has been charged and is standing still in the detector.		
2	Make sure the S-SFC has started up and is ready to communicate with the flowmeter.	MAG XXXXXXXX READY...	MAG XXXXXXXX ツギノ ソウサマ トウソク
3	Press the SHIFT key.	SHIFT-	シフト-
4	Press the OUTPUT key.	INPUT XXXXXXXX WORKING INPUT XXXXXXXX 0.2 t/h	ニューリヨク XXXXXXXX ツウシンチュウ ニューリヨク XXXXXXXX 0.2 t/h
5	Press the CORRECT key.	INPUT XXXXXXXX ZERO INPUT?	ニューリヨク XXXXXXXX ニューリヨクハ セロテスカ?
6	Press the ENTER  key. <u>Result:</u> <ul style="list-style-type: none"> The screen will change to the display shown in the figure on the upper right-hand side, and the zero adjustment will start. When zero adjustment has been completed, the screen will change to the display shown in the figure on the lower right-hand side. It takes about 30 seconds for zero adjustment. 	INPUT XXXXXXXX WORKING INPUT XXXXXXXX INPUT ZEROED	ニューリヨク XXXXXXXX ツウシンチュウ ニューリヨク XXXXXXXX ゼロロウセイ カンリョウ
7	Press the CLR key to return to the display screen in Step 2.		

3.3 Stopping

 Caution
<ul style="list-style-type: none">• Before stopping the flowmeter operation and shutting off the output to the control equipment, be sure to switch the control equipment to manual control. This will prevent the power shut-off on this unit from directly affecting the control equipment.

Procedures

Perform the following steps to stop flowmeter operation.

Step	Procedure
1	Switch the control equipment connected to the flowmeter to the manual control mode.
2	Turn the power switch of the flowmeter OFF.

3.4 Setting the Communication Function

Introduction

Configuration via communications requires changing the converter mode.

Procedure 1

To communicate with the device, set the switches as follows.

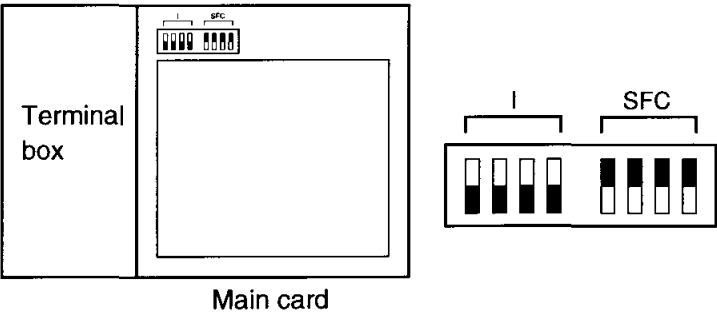
Step	Procedure
1	<p>The main card will be visible. Set the SFC and I switches on the upper part of the card as shown below. (Move the switches to the blackened positions.)</p>  <p>The diagram illustrates the switch configuration. On the left is a 'Terminal box'. To its right is the 'Main card', which has a 'SFC' switch group at the top. A separate detail to the right shows the 'I' and 'SFC' switch groups. The 'I' group has four switches, and the 'SFC' group has four switches. In the detail, the top half of each switch in both groups is blackened, indicating they should be moved to that position.</p>

Continued on next page

3.4 Setting the Communication Function Continued

Procedure 2

When not using communications, set the switches as followings.

Step	Procedure
1	Remove the display cover.
2	Set the SFC and I switches on the top of the main card as shown below. (Move the switches to the blackened positions.) <div data-bbox="859 600 1165 757" style="text-align: center;"></div>

3.5 Setting Write Protection

Introduction

This product is set up at shipment so that settings can be made in any mode. However, write protection can be set to protect data from being accidentally changed after start-up.

Levels of write protect

The following write-protect levels are available. The product is set to level 0 when shipped.

Level	Operator's Mode	Engineering Mode	Maintenance Mode	Remarks
0	○	○	○	When shipped
1	○	○	×	
2	○	△	×	
3	△	△	×	

○: Both data confirmation and manipulation are possible.

△: Only data confirmation is possible.

×: Neither data confirmation nor manipulation is possible.

Procedure 1

To change the write-protect level, set the switches in the following steps.

Step	Procedure
1	Remove the display cover.
2	<p>The switches are located on the main card. Set switches LEV1, LEV2, and LEV3 on the top of the card as shown below. (Move the switches to the blackened positions.)</p> <p>The diagram shows a 'Main card' with a 'Data setting device' and a 'Pulse card' on top. Three switches are labeled LEV1, LEV2, and LEV3. To the right, four switch configurations are shown for write protection levels 0, 1, 2, and 3. In each configuration, a black square indicates the switch is in the 'blackened' position. Level 0: all three switches (LEV1, LEV2, LEV3) are black. Level 1: only LEV1 is black. Level 2: only LEV2 is black. Level 3: both LEV1 and LEV2 are black.</p>

3.6 Setting the Empty Detection Function

Introduction

This function fixes the output at 4 mA and latches the display to zero when the detector becomes empty.

Procedures

To set the empty detection function, set the switches in the following steps.

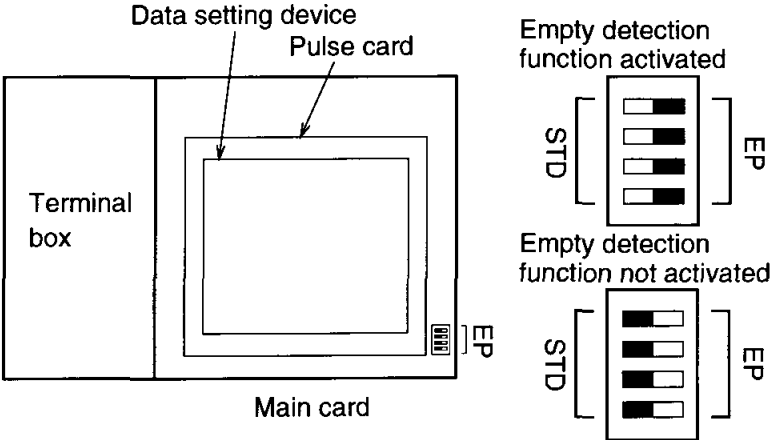
Step	Procedure
1	Remove the display cover.
2	<p>The switches are located on the main card. Set switches EP and STD on the right of the card as shown below. (Move the switches to the blackened positions.)</p>  <p>The diagram illustrates the hardware components and switch settings. On the left is a 'Terminal box'. To its right is the 'Main card', which contains a 'Data setting device' and a 'Pulse card'. On the right side of the main card, there are two switches labeled 'STD' and 'EP'. Two configurations are shown: <ul style="list-style-type: none"> Empty detection function activated: Both the STD and EP switches are shown with black bars, indicating they are in the 'on' position. Empty detection function not activated: Both the STD and EP switches are shown as white, indicating they are in the 'off' position. </p>

MEMO

Chapter 4 - Operation Using the Data Setting Device

Outline of this chapter

This chapter explains how to operate this product using the data setting device.

Read this chapter only if this device has a data setting device. Refer to the S-SFC user's manual CM1-MGG000-2001 or CM2-MGG000-2001 "Device Smart Electromagnetic Flowmeter S-SFC II User's Manual" if using an S-SFC data setter.

The device can be operated using the 4 keys on the data setting device.

4.1 Functions of the Data Setting Device

Data Setting Device

Names of parts

Figure 4-1 shows describes the parts of the data setting device.

Figure 4-1 Names of data setter parts

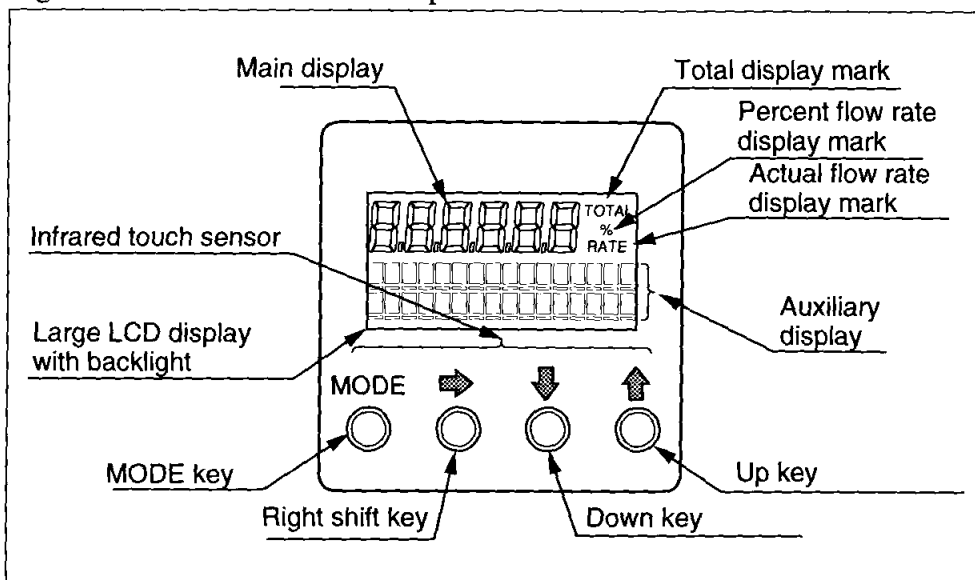

Part names and explanation

The display that appears on the data setting device is explained below.

- Flow rate indication
The display indicates “%” for percent flow rate, “RATE” for actual flow rate, and “TOTAL” for the integrated value.

Section	Explanation
7-segment 6-digit display	<ul style="list-style-type: none"> • Indicates the flow rate selected in the Operator’s Mode.
Percent flow rate indicator (%)	<ul style="list-style-type: none"> • Indicates that percent flow rate is currently displayed.
Actual flow rate indicator (RATE)	<ul style="list-style-type: none"> • Indicates that actual flow rate is currently displayed.
Integrated value indicator (TOTAL)	<ul style="list-style-type: none"> • Indicates that the integrated value is currently displayed.
Auxiliary display	<ul style="list-style-type: none"> • During the Measuring Mode, indicates a flow rate to supplement the flow rate indication selected in the Operator’s Mode. • Indicates the integrated flow value when pulse is selected. • Indicates the procedures for parameter setting, adjustment, etc. when not in the Measuring Mode.



(Continued on next page)



Data Setting Device Continued

Part names and explanation

The following is an explanation of the various keys on the data setting device.

- When operating the keys, be sure to close the cover. Only touch the keys through the glass.
- When operating the keys, touch the glass lightly, targeting the central part of each key.

Hold down the  or  key to scroll the characters up to 40 times.

Name	Explanation
<p>MODE key</p> <p style="text-align: center;">MODE</p> 	<ul style="list-style-type: none"> • Enter the Operator's Mode. • After changing the parameters or internal data in the Engineering Mode or Maintenance Mode, press this key to write the data into memory. • Touch this key for more than one second to complete the write.
<p>Right-shift key</p> 	<ul style="list-style-type: none"> • Shift the cursor to the right.
<p>Down key</p> 	<ul style="list-style-type: none"> • Change the parameter at the cursor position. • Display the previous screen. <p>When the cursor is located at the far left of the upper row (*, #, >)</p> <div style="border: 1px solid black; padding: 5px; margin-bottom: 10px;"> <p>* OPERATOR' S MODE</p> <p>— Cursor</p> </div> <p>Changes the screen.</p> <p>When the cursor is located at a numerical figure</p> <div style="border: 1px solid black; padding: 5px; margin-bottom: 10px;"> <p>* DAMPING 0 0 1 . 0 S</p> <p>— Cursor</p> </div> <p>Decrements the numerical figure.</p> <p>When the cursor is located at the decimal point</p> <div style="border: 1px solid black; padding: 5px;"> <p># 1. 0 0 0 0 m/s SPAN 0 7 . 0 6 9 m³/h</p> <p>— Cursor</p> </div> <p>Moves the decimal point to the right.</p>

(Continued on next page)

Data Setting Device Continued

Part names and explanation
(continued)

Name	Explanation
<p>Up key</p> 	<ul style="list-style-type: none"> • Change the parameter at the cursor position. • Display the next screen. <p>When the cursor is located at the far left of the upper row (*, #, >)</p> <div data-bbox="816 589 1237 725" style="border: 1px solid black; padding: 5px;"> <p>* OPERATOR' S MODE</p> <p>Cursor</p> </div> <p>Changes the screen.</p> <p>When the cursor is located at a numerical figure</p> <div data-bbox="816 808 1237 945" style="border: 1px solid black; padding: 5px;"> <p>* DAMPING 0 0 1 . 0 S</p> <p>Cursor</p> </div> <p>Increments the numerical figure.</p> <p>When the cursor is located at the decimal point</p> <div data-bbox="816 1025 1237 1162" style="border: 1px solid black; padding: 5px;"> <p># 1. 0 0 0 0 m / s SPAN 0 7 . 0 6 9 0 m³ / h</p> <p>Cursor</p> </div> <p>Moves the decimal point to the left.</p> <p>When the cursor is located at "READY"</p> <div data-bbox="816 1243 1237 1379" style="border: 1px solid black; padding: 5px;"> <p>* AUTO ZERO READY</p> <p>Cursor</p> </div> <p>Starts operation when touched.</p>

Operating the Display/Data Setting Device

Outline of the various modes

The following 4 modes are available on the device.

Mode	Explanation
<div style="border: 1px solid black; padding: 5px; text-align: center;">MEASURING MODE</div>	<p>This mode indicates the measuring status.</p>
<div style="border: 1px solid black; padding: 5px; text-align: center;">OPERATOR'S MODE</div>	<p>The operator setting mode is used for data that are registered or changed frequently. The settings can be changed at start-up and on other occasions when write protect is set to level 0, 1, or 2. With level 3, only configuration data monitoring is available. Includes damping time constant, auto zero adjustment, counter reset, counter preset value.</p> <p>Note:</p> <ul style="list-style-type: none"> Registered or changed data is temporarily written in to memory when input, but will return to the previous status within two minutes unless it is saved. (exception: only counter reset will not return to the previous status even after 2 minutes.) <p>To save the data, be sure to press the MODE key to open the Measuring Mode.</p> <p>When the mode changes to the Measuring Mode, the data will be written into memory.</p>

(Continued on next page)

Operating the Display/Data Setting Device Continued

Outline of the various modes (continued)

Mode	Explanation
<div style="border: 1px solid black; padding: 5px; text-align: center;">ENGINEERING MODE</div>	<p>This is the engineering setting mode. It is used for data that are registered or changed less frequently than in the Operator's Mode.</p> <p>Settings can be registered or changed when write protect is set to level 0 or 1. When the level is 2 or 3, only configuration data monitoring is available. Includes ID function setting, detector data, flow rate span, hysteresis width, pulse data, low flow cut, output at error.</p> <p>Note:</p> <ul style="list-style-type: none"> • When registering or changing data, be sure to press the MODE key to write it to non-volatile memory. Rewriting occurs when the mode is changed to the Measuring mode by pressing the MODE key.
<div style="border: 1px solid black; padding: 5px; text-align: center;">MAINTENANCE MODE</div>	<p>This is the maintenance setting mode. It is used when adjustment or verification is needed at regular maintenance periods or when an abnormality occurs. Settings can be adjusted or confirmed only when the write protect level is set at 0. Includes loop check, output adjustment, gain adjustment.</p> <p>This mode is further divided into the following 3 modes:</p> <p style="text-align: center;">OUTPUT CHECK MODE CALIBRATION MODE CRITICAL MODE</p> <p>Notes:</p> <ul style="list-style-type: none"> • Calibration Mode and Critical Mode contain adjustments and operations that are very important for flow rate measurement. When operating these modes, fully check the details of the adjustments to be made. • Missetting will prevent measurement. • When registering or changing data, be sure to press the MODE key to write it to non-volatile memory. Rewriting occurs when the mode is changed to the Measuring mode by pressing the MODE key.

Screen Organization

Introduction

The device modes are arranged as follows.

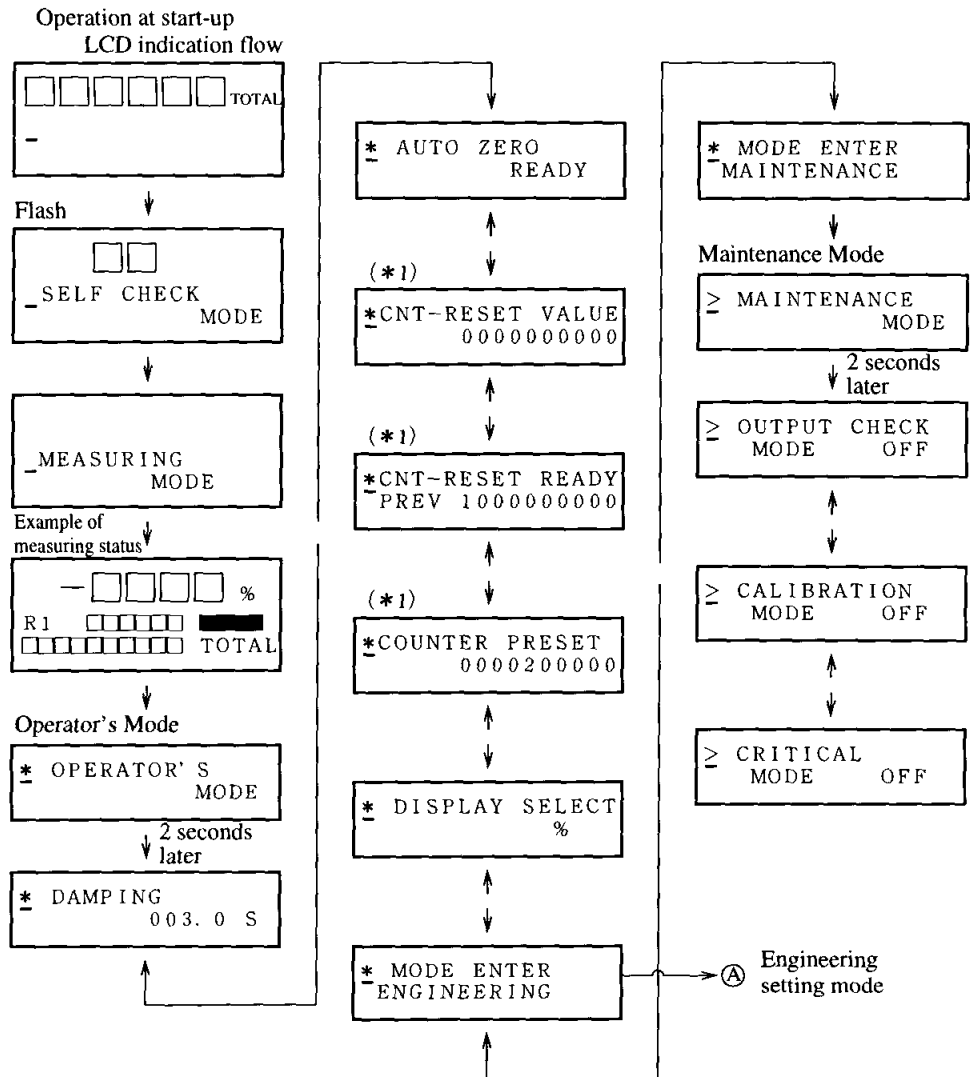

(Continued on next page)

Screen Organization *Continued*

Introduction (continued)

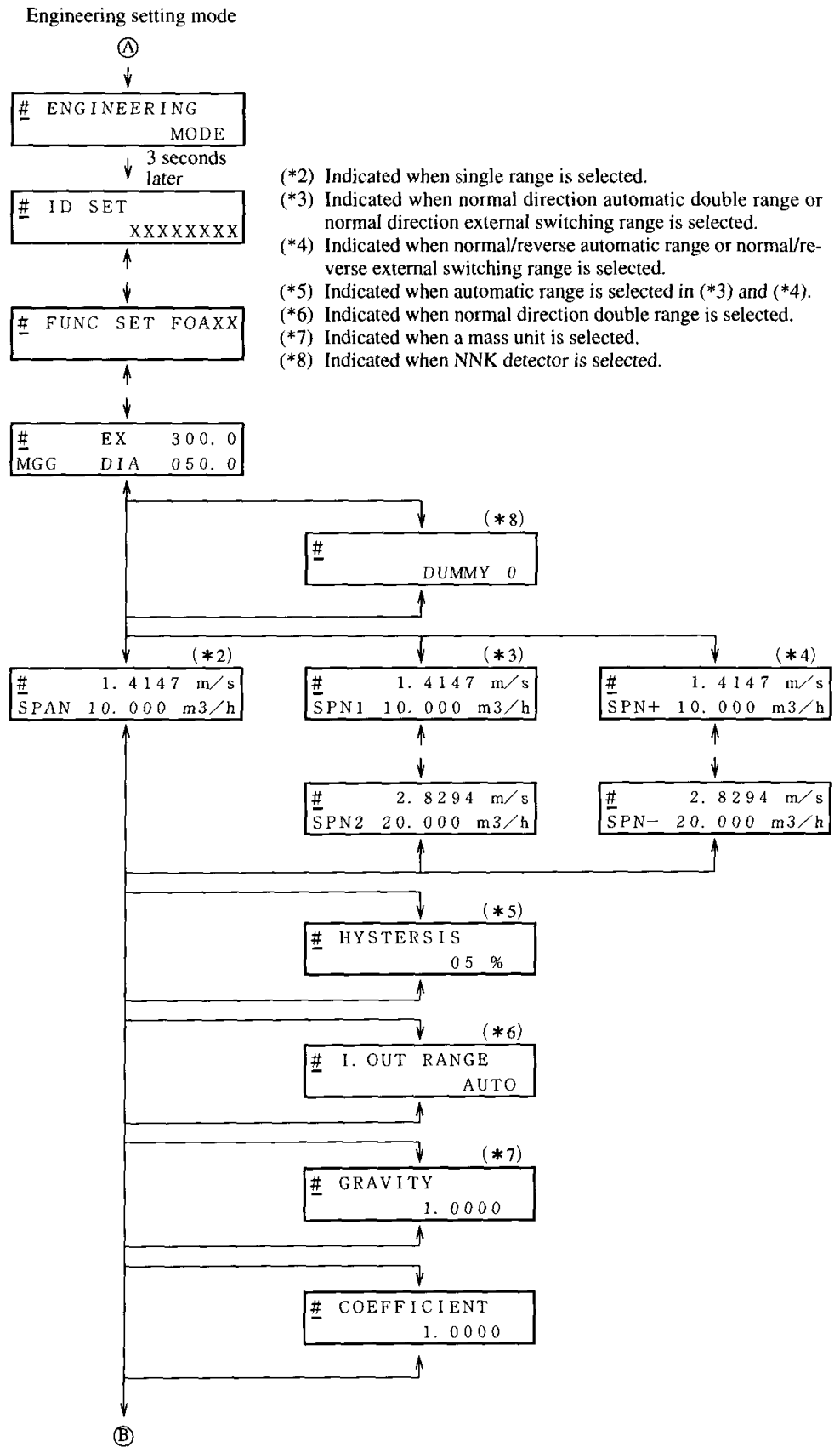

(Continued on next page)





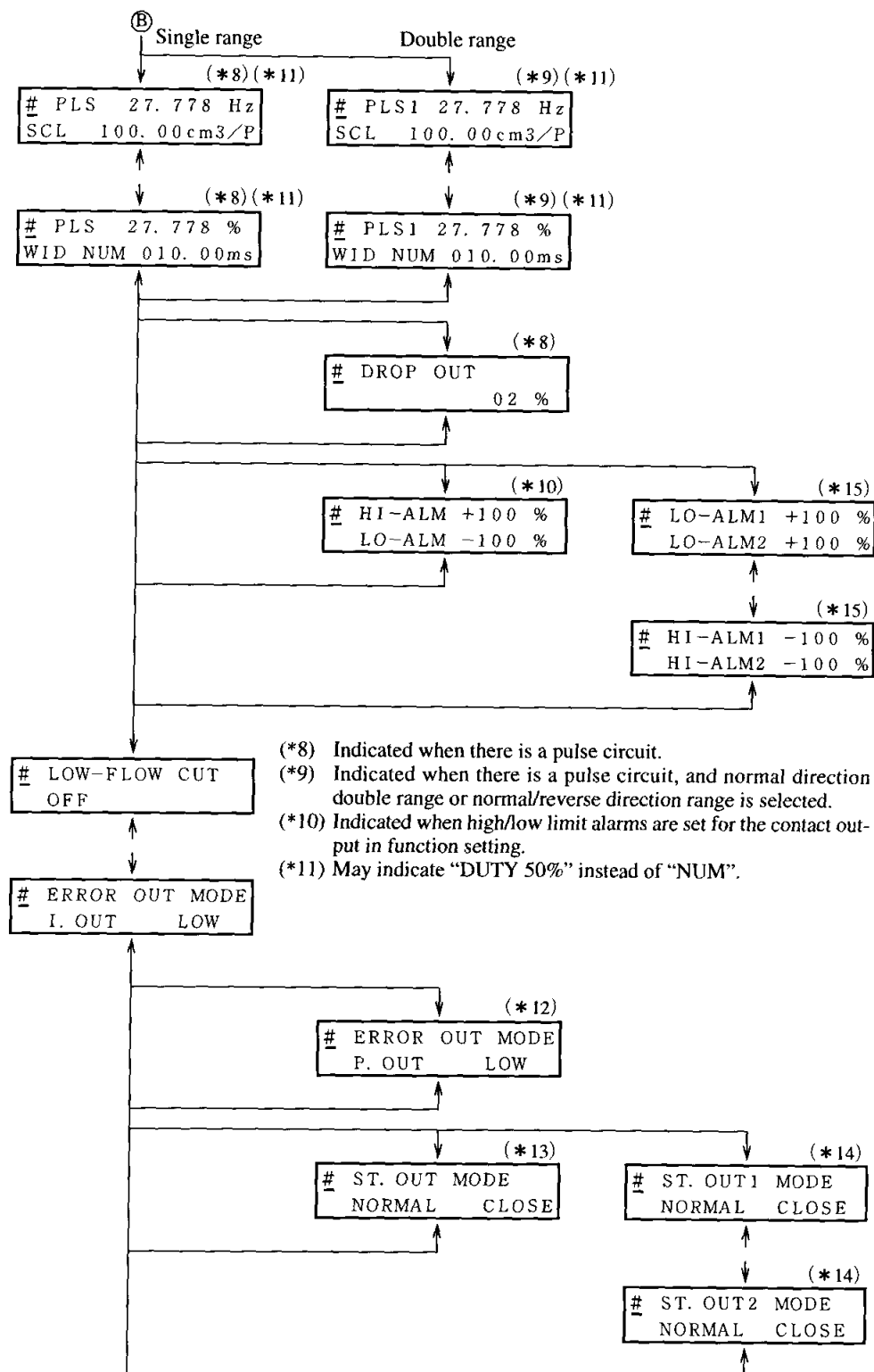

Screen Organization Continued

Introduction (continued)





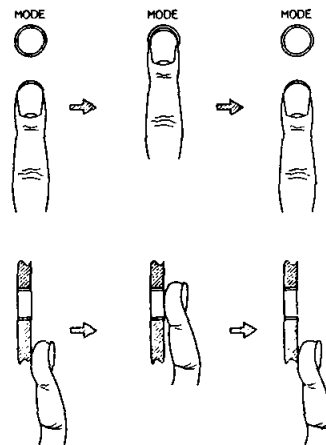

- (*12) Indicated when there is a pulse circuit.
- (*13) Indicated when contact output is registered in function setting.
- (*14) Indicated when 2-contact output is used.
- (*15) Indicated when Single Range HH/LL is selected in function setting.

How to Skillfully Operate the Touch Key Switches

1. As illustrated, move your finger upward from underneath the target, and completely cover the white round target. Then, move the finger downward to its original position. These motions ensure smooth key operation. If you move your finger sideways, you may inadvertently actuate the wrong key.
2. To enter the MODE key, keep touching the key for 3 seconds. Release the key on completion of screen change to ensure smooth operation. If the screen change is not completed within 3 seconds, move the finger off, and touch the MODE key again 3 seconds later. If you touch the key right away, the input may not be accepted.
3. To enter the , , or  keys in succession (increment or decrement), keep touching the target until the desired display is obtained. Note, however, that the  key stops at the mode signs shown below.
 - * (OPERATOR'S MODE)
 - # (ENGINEERING MODE)
 - > (MAINTENANCE MODE)To move the cursor again, press the  key again. The  and  keys can be incremented or decremented up to 40 times in succession. If you want to make another key entry, press the key again.

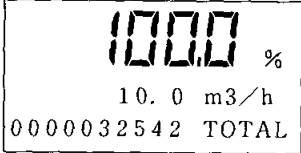

How to Enter the Operator's Mode

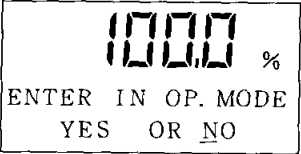
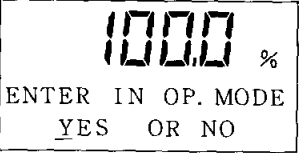
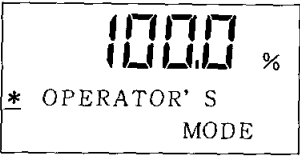
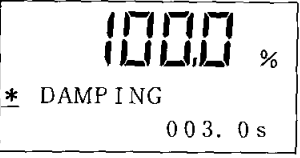
Step	Procedure	Screen
1	The screen at right shows an example of display of 10 m ³ /h, 100% in the Measuring Mode. Touch the MODE key for about 3 seconds.	
2	<p>Complete the following operations within 8 seconds (the screen at right will be displayed for about 8 seconds only):</p> <p>1) To enter the Operator's Mode, move the cursor under "Y" by touching the  key twice, and then touch the  key.</p> <p>2) To return to the Measuring Mode, move the cursor under "N" and touch the  key.</p> <p>The screen will automatically return to the Measuring Mode (screen shown in step 1) 8 seconds later.</p>	 
3	The operation mentioned under 1) in the above step will make the screen on the right be displayed for about 2 seconds.	
4	The Damping Setting screen will be displayed about 2 seconds later.	

Operating in Operator's Mode

Introduction

The Operator's Mode includes the following settings and adjustments. To enter the Operator's Mode, touch the MODE key for more than three seconds.

Screen display	Description	Indicated conditions
DAMPING	Sets the damping time constant	
AUTO ZERO	Performs zero adjustment	
CNT-RESET VALUE	Sets the reset value of the built-in flow counter	Selection of pulse output and TOTAL display.
CNT-RESET	Resets the built-in flow counter to the reset value	Selection of pulse output and the TOTAL display.
COUNTER PRESET	Sets the preset value of the built-in flow counter	Selection of pulse output (in selective specifications) and setting of counter preset (in function setting).
DISPLAY SELECT	Sets the flow rate display	
MODE ENTER ENGINEERING	Enters the Engineering Mode	
MODE ENTER MAINTENANCE	Enters the Maintenance Mode	Setting of write protect to level 0.

Details of the screens are explained on the following pages using concrete examples. To display the various screens, enter the Operator's mode and then press the  key.

Note:

- Settings and adjustments made in the Operator's Mode are temporarily written into memory when input. However, the settings will return to their previous status unless the data are saved within 2 minutes. Be sure to save the data by pressing the MODE key at the end of setting/adjustment.

Resetting the Damping Time Constant

Introduction

Set a damping time constant to cut out minute fluctuations when transmitting the measured instantaneous flow rate to the control equipment. Check the amplitude of variation in instantaneous flow output and set the damping time constant to an appropriate value.







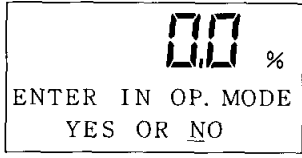
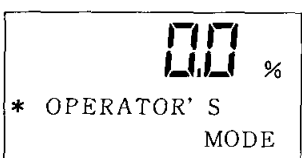
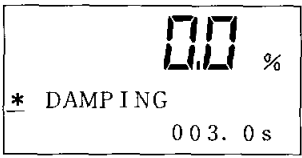

The new value of the damping time constant becomes effective at the moment when the setting is changed.

Default setting

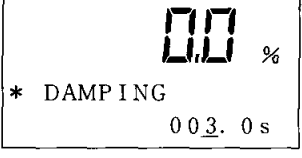
The damping time constant is set to 3 seconds at shipment.

Setting range

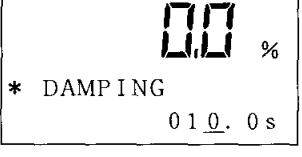
The time constant can be set to any value from 000.5 to 199.9.

Step	Procedure	Screen
1	Touch the MODE key for more than 3 seconds. Note: The screen at left will be displayed for 8 seconds. Complete the following operations within 8 seconds.	
2	Touch the MODE key for more than one second.	
3	About 2 seconds after that, the screen will indicate the damping time constant setup display.	
4	Touch the  key three times.	
5	Touch the  or  key to indicate the desired time constant. In this example, damping time is changed from 3 seconds to 10 seconds by six touches of the  key. The value can also be changed by holding down the key.	
6	Touch the  key twice.	





Zero Adjustment

Introduction

Adjust the flowmeter so that the measured instantaneous flow rate will be zero when the fluid stands still in the detector.

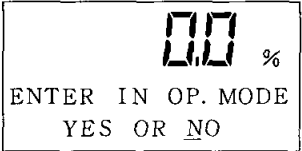
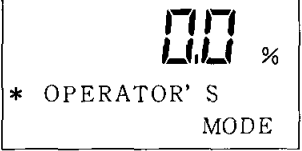
Notes:

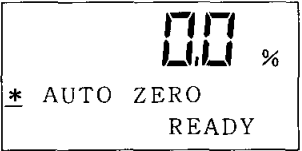

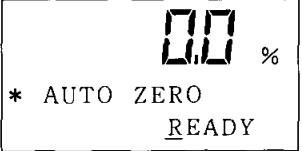
- Zero adjustment is very important for accurate flow measurement. Before operating the unit for the first time, be sure to zero the flowmeter.
- Before zero adjustment, make sure the detector has proper Class 3 grounding and that the fluid to be measured is charged into the detector and is standing still. Zero adjustment is possible when the flow speed is 0.2 m/s or below, but wait until the fluid completely stops (flow speed: 0.0 m/s) for accurate adjustment. Otherwise, output errors may result.

Step	Procedure	Screen
1	Touch the MODE key for more than 3 seconds. Note: The screen at left will be displayed for 8 seconds. Complete the following operations within 8 seconds.	
2	Touch the MODE key for more than one second.	
3	Touch the MODE key on the data setting device for more than one second to enter the Operator's Mode. Touch the  key to open the screen shown at right. Note: The figure shows the screen when the main display is set at %.	
4	Touch the  key once.	

(Continued on next page)

Zero Adjustment Continued

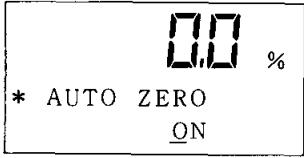
Zero Adjustment Continued

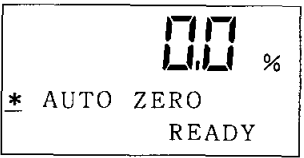
Step	Procedure	Screen
5	Touch the  key to start zero adjustment. When the large 7-segment display shows the flow rate in percent, "0.0" will flash during adjustment. When zero adjustment is completed, the flashing will stop and the "ON" message will return to "READY." It takes about 30 seconds for zero adjustment.	
6	Touch the  key once.	

Setting the Reset Value of the Built-in Flow Counter

Introduction

This sets and changes the integration starting value of the built-in flow counter.







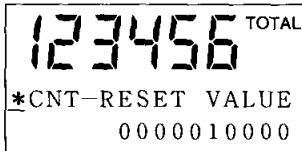

This function is used when a pulse output board has been selected (additional specification).

Default setting

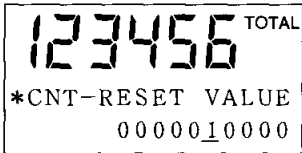
The reset value is set to "0000000000" at shipment.

Setting range

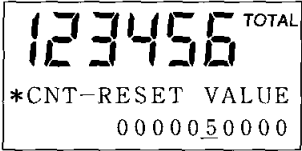

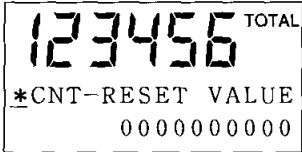



-999999999 - 9999999999

Step	Procedure	Screen
1	Open the built-in flow counter reset value setup screen by following the steps to enter the Operator's Mode.	
2	Touch the  key to move the cursor to the desired numerals. In this example, the cursor is moved to the position of the "1" by touching the  key several times. (You can also hold down the key.)	
3	Touch the  or  key to set the desired numbers. In this example, the number "1" is changed to "5" by four touches of the  key.	
4	Touch the  key to return the cursor to the "*".	

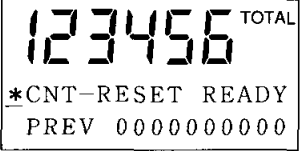
Resetting the Built-in Flow Counter

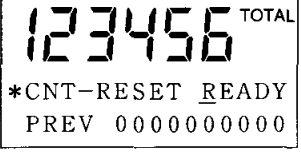
Introduction

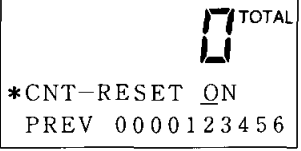
This resets the current integrated flow rate and saves it to memory. The built-in counter indicates “0000000000” at power-up. This function is used when a pulse output board has been selected (additional specification).

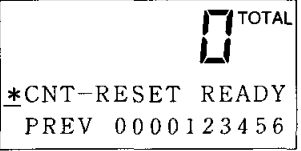
Step	Procedure	Screen
1	Open the built-in counter reset screen by entering the Operator's Mode.	
2	Touch the  key once.	
3	Touch the  key to reset the counter. About 0.5 seconds later, the “ON” message will return to “READY”, and resetting is completed.	
4	Touch the  key once.	

Setting/Changing the Preset Value of the Built-in Flow Counter

Introduction

This changes the contact output status from H to L or from L to H when the flow counter reaches a preset value.

This function is used when contact output has been selected (additional specification) and pulse output has been selected (additional specification).







Also, be sure to select the preset counter for the contact output in function setting.

Default setting

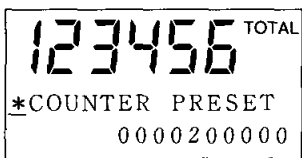
The preset value is set to "0000000000" at shipment.

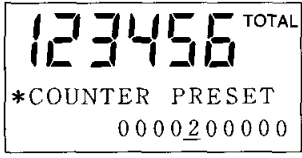
Setting range

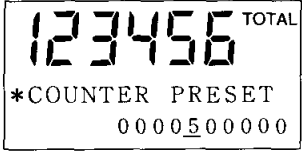
0000000000 - 9999999999

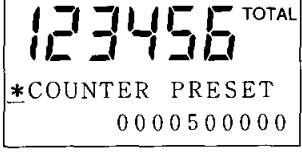
Step	Procedure	Screen
1	Open the built-in flow counter preset value setup screen by following the steps to enter the Operator's Mode.	
2	Touch the  key to move the cursor to the desired digits. In this example, the cursor is moved to the "2" position by touching the  key five times.	
3	Touch the  or  key to set the desired numbers. In this case, the numeral "2" is changed to "5" by five touches of the Increment key.	
4	When the counter reset value has been changed, touch the  key to return the cursor to the "*".	

Setting/Changing the Flow Rate Indication

Introduction

Selects the mode of flow rate indication for the main display: from percent display: actual flow rate display, and integrated value display.

Default setting

The default setting is percent display.

Setting range

Select either “%” (instantaneous percent flow rate), “RATE” (instantaneous actual flow rate), or “TOTAL” (integrated value).

Step	Procedure	Screen
1	Open the flow rate display setup screen by following the steps to enter the Operator's Mode.	
2	Touch the key once.	
3	Touch the or key to select the desired flow rate display. In this example, “%” is changed to “RATE” by one touch of the key.	
4	Touch the key once.	
5	Perform setting for the “TOTAL” display as well.	

Selecting Modes





Introduction

Select either the Engineering Mode (to operate the setting parameters of the electromagnetic flowmeter) or the Maintenance Mode (to perform adjustments or inspection).

Note:

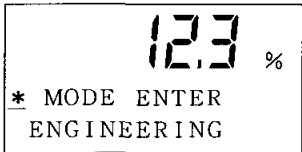
- In some cases, a mode selection screen will not open, depending on the write-protect setting. Only the Engineering Mode selection screen will open if the write-protect switches on the main board are used to select level 1, 2, or 3. If level 0 is selected, both the Engineering Mode and the Maintenance Mode will open. Refer to Chapters 3 and 5.

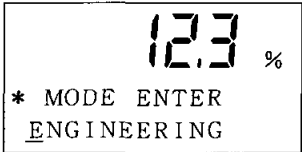
To enter the Engineering Mode

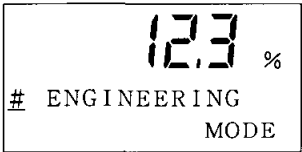
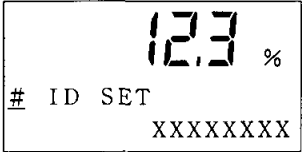





Step	Procedure	Screen
1	Call up the Engineering Mode selection screen by following the steps to enter the Operator's Mode.	
2	Touch the  key once.	
3	Touch the  key, and the display will change to the Engineering Mode.	
4	Two seconds later, the display shown at right will appear.	

(Continued on next page)

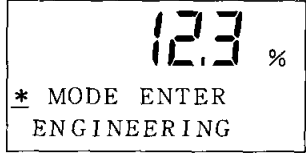
Selecting Modes Continued

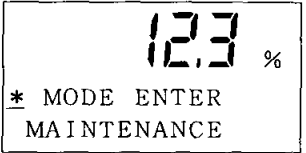
Introduction
(continued)

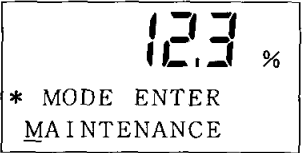
To enter the Maintenance Mode

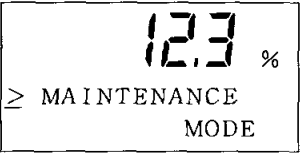
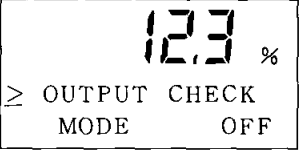
Step	Procedure	Screen
1	Call up the Maintenance Mode selection screen by following the steps to enter the Operator's Mode.	
2	Touch the  key once.	
3	Touch the  key once.	
4	Touch the  key, and the display will change to the Maintenance Mode.	
5	Two seconds later, the display shown at right will appear.	

Engineering Mode

Introduction

The Engineering Mode contains the following settings and adjustments.

Screen display	Description	Indicated conditions
ID SET	Sets the ID	
FUNC SET	Sets the functions	
EX, TYPE, DIA	Sets detector data	
DUMMY	Sets the number of dummy detectors	Selection of an NNK detector in the detector data setting.
SPAN	Sets the range	
HYSTERESIS	Sets the hysteresis	Selection of normal direction automatic double range or normal/reverse direction automatic double range in function setting.
I. OUT RANGE	Selects the electromagnetic output method	Selection of normal direction automatic or external double range or normal/reverse direction automatic or external double range in function setting.
GRAVITY	Selects the specific gravity	Selection of a weight unit (t, kg, g, lb) in range setting.
COEFFICIENT	Selects the coefficient of compensation	
PLS SCL	Sets the pulse scale	Selection of pulse output (option).
PLS WID	Selects the pulse width	Selection of pulse output (option).
DROP OUT	Sets the drop out	Selection of pulse output (option).

(Continued on next page)

Engineering Mode Continued

Introduction (continued)

Screen display	Description	Indicated conditions
HI-ALM/LO-ALM	Sets high/low limit alarms	Selection of alarm output and high/low limit alarms in function setting (option).
LO-ALM1/LO-ALM2	Sets the 2-stage low limit alarm	Selection of 2-stage low alarm in function setting (option).
HI-ALM1/HI-ALM2	Sets the 2-stage high limit alarm	Selection of 2-stage high limit alarm in function setting (option).
LOW-FLOW CUT	Sets the low flow cut	
ERROR OUT MODE P.OUT	Determines the pulse output abnormality treatment direction	Selection of pulse output (option).
ERROR OUT MODE I.OUT	Determines the analog output abnormality treatment direction	
ST.OUT MODE	Sets the contact output status	Selection of contact input/output (option).

Details of the various screens are explained on the following pages. To open the various screens, press the  key after entering Engineering Mode.

Note:

- To write data set in the Engineering Mode to non-volatile memory, press the MODE key. When changing data, be sure to press the MODE key.

Setting the ID

Introduction







Sets the ID code for the electromagnetic flowmeter.

Default setting

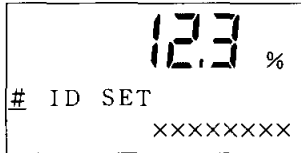
XXXXXXXX

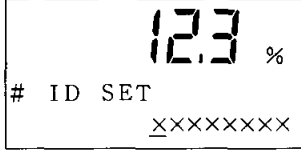
Setting range

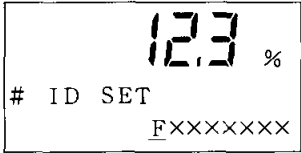
The ID code can be set using up to 8 alphanumeric characters: letters (A to Z), numbers to 9), -, /, space, and period.

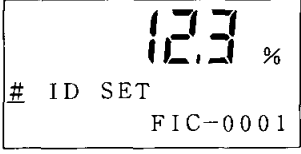
Step	Procedure	Screen
1	Open the ID setup display by following the steps to enter the Engineering Mode.	 <p>12.3 % # ID SET XXXXXXXX</p>
2	Touch the  key to move the cursor to the characters to be changed.	 <p>12.3 % # ID SET xXXXXXXXX</p>
3	Touch the  or  key to change the characters to the desired ones. Use the Right-shift, Down, and Up keys to set up the desired code.	 <p>12.3 % # ID SET FXXXXXXXX</p>
4	When the desired tag No. is shown, touch the  key to move the cursor to the "*".	 <p>12.3 % # ID SET FIC-0001</p>











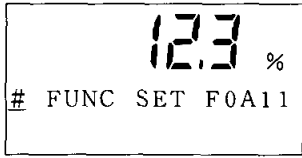

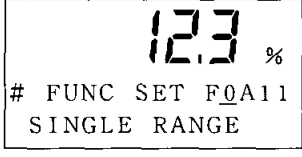
Selecting Functions

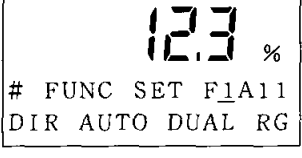
Introduction

Sets the electromagnetic flowmeter functions: range, counter, contact input, and contact output.

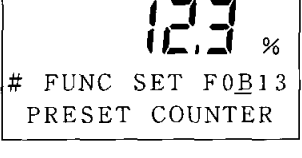
There will be restrictions on the functions that can be set depending on your model's specifications. Note that the setting range will be limited depending on whether or not a pulse output board is used and the kind of contact input/output boards.



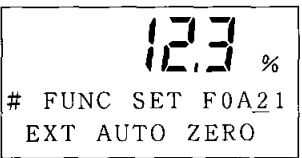

The possible combinations are shown on the following pages.

Step	Procedure	Screen
1	Open the function setup screen by following to the steps to enter the Engineering Mode.	
2	Touch the  key to select the kind of function settings. One touch is for range setting, two touches for built-in counter setting, three touches for the contact input function setting, and four touches for the contact output function setting.	
3	Touch the  or  key to select the desired function.	
4	Two touches of the  key in Step 1 enables the selection of the built-in counter function. Touch the  or  key to select the desired function.	
5	Three touches of the  key in Step 1 enables the selection of the contact input function. Touch the  or  key to select the desired function.	

(Continued on next page)

Selecting Functions Continued

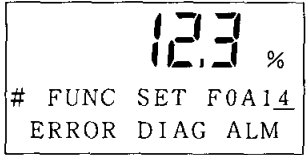
Introduction
(continued)

Step	Procedure	Screen
6	Four touches of the  key in Step 1 enables the selection of the contact output function. Touch the  or  key to select the desired function.	
7	When completing the settings of the respective functions, touch the  key to move the cursor to the “#”.	

Relations for Setting Function FXXXX

Introduction

The range, built-in counter, contact input, and contact output functions can be set using the combinations shown in the table below. For example, when “Single range” and “Addition with preset” are selected, there are three contact input choices (X, 1, and 2) and three contact output choices.

1-contact input and 1-contact output (DI/DO)

Range function	Built-in counter function	Contact input function	Contact output function
0: Single range	X: Not activated	X: Not activated	X: Not activated
			1: Alarm output
			4: Self-check result output
			5: Empty detection function
			6: High/low limit alarm
			1: External 0% lock
		X: Not activated	
		1: Alarm output	
		4: Self-check result output	
	5: Empty detection function		
	6: High/low limit alarm		
	2: External auto zero adjustment		
	X: None		
	1: Alarm output		
	4: Self-check result output		
	5: Empty detection function		
	6: High/low limit alarm		
	A: Addition	X: Not activated	X: Not activated
1: Alarm output			
4: Self-check result output			
5: Empty detection function			
6: High/low limit alarm			
1: External 0% lock			
X: Not activated			
1: Alarm output			
4: Self-check result output			
5: Empty detection function			
6: High/low limit alarm			
2: External auto zero adjustment			
X: Not activated			
1: Alarm output			
4: Self-check result output			
5: Empty detection function			
6: High/low limit alarm			
4: Counter reset	X: Not activated	X: Not activated	X: None
			1: Alarm output
			4: Self-check result output
			5: Empty detection function
			6: High/low limit alarm
			B: Addition with preset
1: External 0% lock			
2: External auto zero adjustment			
			3: Preset output
			3: Preset output

(Continued on next page)

Relations for Setting Function FXXXX Continued

Introduction (continued)

1-contact input and 1-contact output (DI/DO) (continued)

Range function	Built-in counter function	Contact input function	Contact output function	
1: Automatic switching double range	X: Not activated	X: Not activated	2: Range switching output	
		1: External 0% lock	2: Range switching output	
		2: External auto zero adjustment	2: Range switching output	
	A: Addition	X: Not activated	2: Range switching output	
		1: External 0% lock	2: Range switching output	
		2: External auto zero adjustment	2: Range switching output	
2: External switching double range	X: Not activated	3: External range switching	X: Not activated	
			1: Alarm output	
			4: Self-check result output	
	A: Addition	3: External range switching	X: Not activated	
			1: Alarm output	
			4: Self-check result output	
	B: Addition with preset	3: External range switching	3: Preset output	
			2: Range switching output	
			2: Range switching output	
3: Normal/reverse automatic switching range	X: Not activated	X: Not activated	2: Range switching output	
		1: External 0% lock	2: Range switching output	
		2: External auto zero adjustment	2: Range switching output	
	A: Addition	X: Not activated	X: Not activated	2: Range switching output
			1: External 0% lock	2: Range switching output
			2: External auto zero adjustment	2: Range switching output
	C: Normal/reverse flow integration	X: Not activated	X: Not activated	2: Range switching output
			1: External 0% lock	2: Range switching output
			2: External auto zero adjustment	2: Range switching output
	4: Normal/reverse external switching range	X: Not activated	3: External range switching	X: Not activated
				1: Alarm output
				4: Self-check result output
A: Addition		3: External range switching	X: Not activated	
			1: Alarm output	
			4: Self-check result output	
B: Addition with preset		3: External range switching	3: Preset output	
			2: Range switching output	
			2: Range switching output	
C: Normal/reverse flow integration		3: External range switching	X: Not activated	
			1: Alarm output	
			4: Self-check result output	
			5: Empty detection function	
			6: High/low limit alarm	
			6: High/low limit alarm	

(Continued on next page)

Relations for Setting Function FXXXX Continued

Introduction
(continued)

2-contact input (DI/DI)

Range function	Built-in counter function	Contact input function	Contact output function		
0: Single range	X: Not activated	X: Not activated	X: Not activated		
		1: External 0% lock	X: Not activated		
		2: External auto zero function	X: Not activated		
		5: External 0% lock+Auto zero adjustment	X: Not activated		
		A: Addition	X: Not activated	X: Not activated	
	A: Addition	1: External 0% lock	X: Not activated		
		2: External auto zero function	X: Not activated		
		4: Counter reset	X: Not activated		
		5: External 0% lock+Auto zero adjustment	X: Not activated		
		7: External 0% lock+Counter reset	X: Not activated		
		9: External auto zero+Counter reset	X: Not activated		
		2: External switching double range	X: Not activated	3: External range switching	X: Not activated
6: External 0% lock+Range switching	X: Not activated				
8: External auto zero adjustment+Range switching	X: Not activated				
A: Addition	3: External range switching		X: Not activated		
	6: External 0% lock+Range switching		X: Not activated		
	8: External auto zero adjustment+Range switching		X: Not activated		
	A: External range switching+Counter reset		X: Not activated		
	4: Normal/ reverse external switching range		X: Not activated	3: External range switching	X: Not activated
				6: External 0% lock+Range switching	X: Not activated
8: External auto zero adjustment+Range switching		X: Not activated			
A: Addition		3: External range switching	X: Not activated		
		6: External 0% lock+Range switching	X: Not activated		
		8: External auto zero adjustment+Range switching	X: Not activated		
C: Normal/reverse flow integration	X: Not activated	A: External range switching+Counter reset	X: Not activated		
		3: External range switching	X: Not activated		
		6: External 0% lock+Range switching	X: Not activated		
		8: External auto zero adjustment+Range switching	X: Not activated		
		A: External range switching+Counter reset	X: Not activated		

(Continued on next page)

Relations for Setting Function FXXX Continued

Introduction
(continued)

2-contact output (DO/DO)

Range function	Built-in counter function	Contact input function	Contact output function				
0: Single range	X: Not activated	X: Not activated	X: Not activated				
			1: Alarm output				
			4: Self-check result output				
	A: Addition	X: Not activated	X: Not activated	5: Empty detection function			
				6: High/low limit alarm			
				X: Not activated			
				1: Alarm output			
				4: Self-check result output			
				5: Empty detection function			
B: Addition with preset	X: Not activated	X: Not activated	6: High/low limit alarm				
			3: Preset				
			D: Alarm+Preset output				
1: Automatic switching double range	X: Not activated	X: Not activated	2: Range switching output				
			7: Alarm+Range switching output				
			8: Self-check result+Range switching output				
			9: Empty detection function+Range switching output				
			A: High/low limit alarm+Range switching output				
			C: Range switching+Self-check empty detection function				
	A: Addition	X: Not activated	X: Not activated	2: Range switching output			
				7: Alarm+Range switching output			
				8: Self-check result+Range switching output			
				9: Empty detection function+Range switching output			
				A: High/low limit alarm+Range switching output			
				C: Range switching+Self-check empty detection function			
	B: Addition with preset	X: Not activated	X: Not activated	B: Range switching+Preset output			
				2: Range switching output			
				7: Alarm+Range switching output			
3: Normal/reverse automatic switching range	X: Not activated	X: Not activated	8: Self-check result+Range switching output				
			9: Empty detection function+Range switching output				
			A: High/low limit alarm+Range switching output				
			C: Range switching+Self-check empty detection function				
			A: Addition	X: Not activated	X: Not activated	2: Range switching output	
						7: Alarm+Range switching output	
	8: Self-check result+Range switching output						
	9: Empty detection function+Range switching output						
	A: High/low limit alarm+Range switching output						
	C: Range switching+Self-check empty detection function						
	B: Addition with preset	X: Not activated	X: Not activated	B: Range switching+Preset output			
				C: Normal/reverse flow integration	X: Not activated	X: Not activated	2: Range switching output
							7: Alarm+Range switching output
	8: Self-check result+Range switching output						
	9: Empty detection function+Range switching output						
A: High/low limit alarm+Range switching output							
C: Range switching+Self-check empty detection function							

Without DI/DO

Range function	Built-in counter function	Contact input function	Contact output function
0: Single range	X: Not activated	X: Not activated	X: Not activated
	A: Addition	X: Not activated	X: Not activated

Range Functions

Single range

Measures a single range in the normal direction.
The output for a reverse flow will be as follows.

Analog output: Possible to approx. -20% (0.8 mA). With S-SFC communication, to approx. -5% (3.2 mA).

Pulse output: No output

Display: A minus (-) symbol appears.

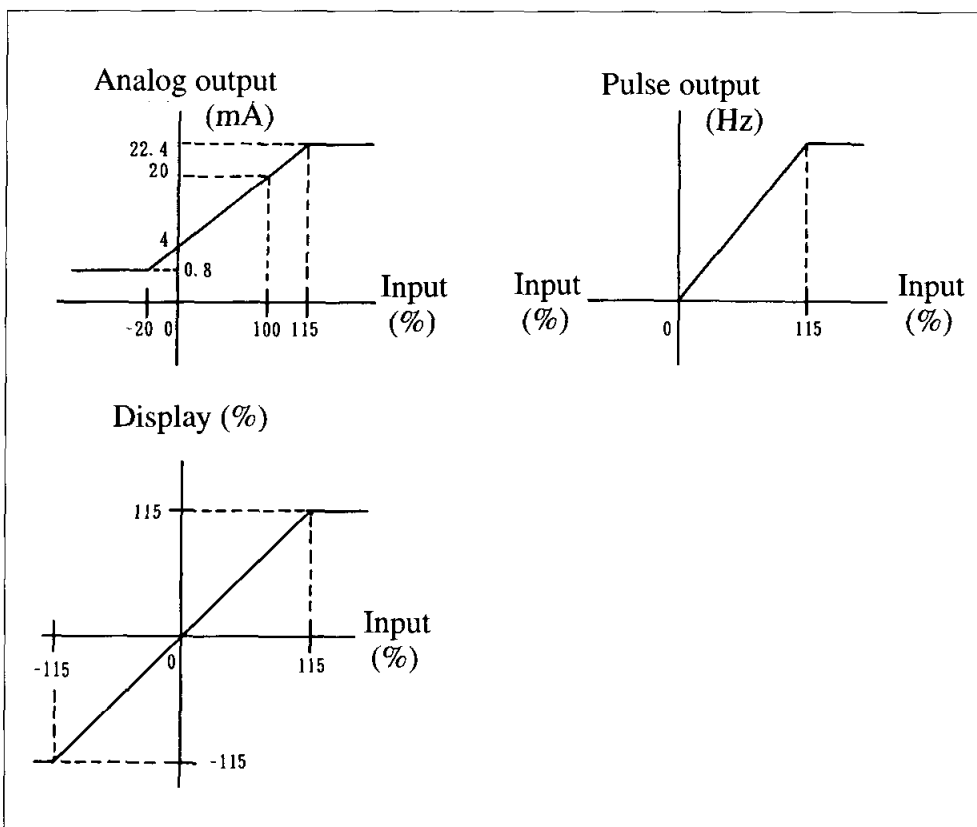

(Continued on next page)

Range Functions Continued

Normal direction automatic double range

This function has two ranges: wide and narrow. When the narrow range measurement exceeds 100%, the unit automatically changes to the wide range. This function should be used in combination with the wide/narrow range distinction output contact. Hysteresis is available when range switching. (See Figure 4-2.)

- ① When AUTO is selected for an analog output
Range No.1 4 - 20 mA DC
Range No.2 4 - 20 mA DC
- ② When WIDE is selected for an analog output
4 - 20 mA DC is output according to either range No.1 or range No.2, whichever has the wider span.

When there is a pulse output

The pulse scale is the same for both ranges No.1 and No.2.

Contact output

At shipment, the contact output status of the distinction status signal for ranges No.1 and No.2 is as follows.

Range No.1: Open

Range No.2: Closed

Reverse setting is also possible.

Figure 4-2 Normal direction automatic double range

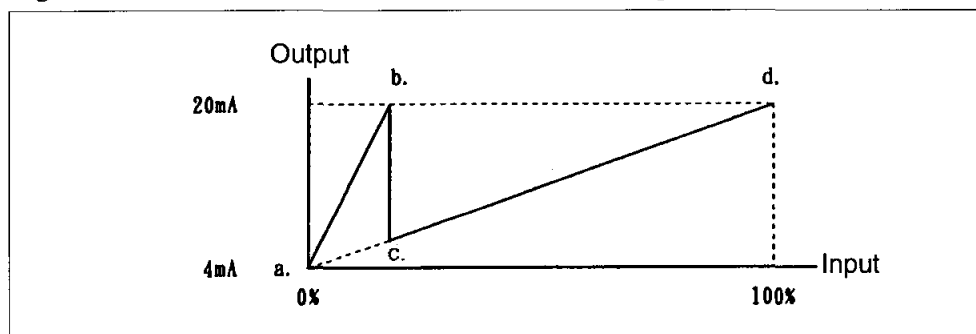

(Example)

- ① AUTO range
 - Range No.1 (narrow range): Outputs 4 - 20 mA for 0 - 10 m³/h (a - b).
 - Range No.2 (wide range): Outputs 4 - 20 mA for 0 - 40 m³/h (a - d).
- ② WIDE range
 - Range No.1 (narrow range): Outputs 4 - 8 mA for 0 - 10 m³/h (a - c).
 - Range No.2 (wide range): Outputs 8 - 20 mA for 0 - 40 m³/h (c - d).

(Continued on next page)

Range Functions Continued

Normal direction, external switching double range

The range is switched via an external switching command contact input. Also, the wide/narrow range distinction contact output (status signal) can be sent out using the same timing.

Analog output

- ① When AUTO is selected for an analog output
Range No.1 4 - 20 mA DC
Range No.2 4 - 20 mA DC
- ② When WIDE is selected for an analog output
4 - 20 mA DC is output according to either range No.1 or range No.2 whichever has the wider span.

When there is a pulse output

The pulse scale is the same for both ranges No.1 and No.2.

Contact input

Range switching command contact input
Range No.1: Open
Range No.2: Closed

Contact output (select functions as required.)

Range switching distinction status signal
The contact output status at shipment is as follows.
Range No.1: Open
Range No.2: Closed

Reverse setting is also possible.

(Continued on next page)

Range Functions Continued

Normal/reverse automatic switching range

Automatically switches the range when the fluid flow direction reverses. Hysteresis is available at the time of normal/reverse switching.

Analog output

Normal direction: 4 - 20 mA DC

Reverse direction: 4 - 20 mA DC

When there is a pulse output

There is no distinction in output between the normal and reverse directions. The pulse scale is also the same.

The built-in counter simply integrates the flow rate without distinguishing normal and reverse directions. However, when normal/reverse differential flow integration is selected, integration of the "-" direction (subtraction) is available.

Example: In the normal direction

-100 → -99 → -98 ... 0 → 1, 2, 3

In the reverse direction

100 → 99 → 98 ... 0 → 1, 2, 3

With indication

With a reverse flow rate, the "-" symbol will appear on the flow rate display. With a pulse output, it is possible to select the normal/reverse differential flow integration function.

Contact output

Normal/reverse distinction status signal

The contact output status at shipment is as follows.

Range No.1: Open

Range No.2: Closed

Reverse setting is also possible.

Figure 4-3 Normal/reverse automatic switching range

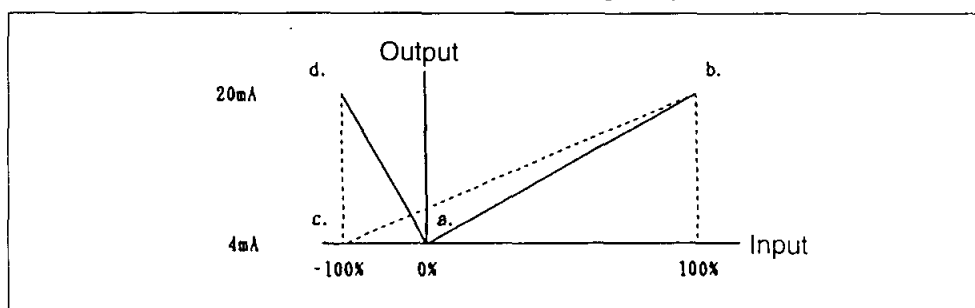

(Example of setting)

① AUTO range

• Range No.1 (narrow range): Outputs 4 - 20 mA for 0 - 10 m³/h (a - d).

• Range No.2 (wide range): Outputs 4 - 20 mA for 0 - 43 m³/h (a - b).

② WIDE range

• Range No.1 (narrow range): Outputs 4 - 8 mA for 0 - 10 m³/h (a - d).

• Range No.2 (wide range): Outputs 8 - 20 mA for 0 - 30 m³/h (c - b).

When WIDE is selected, Low-flow-cut is not performed.

(Continued on next page)

Range Functions Continued

Normal/reverse external switching range

Switches between the normal and reverse ranges by inputting a switching command contact from the gear section.

It is also possible to output the normal/reverse range distinctive contact output (status signal) using the same timing.

Analog output

- ① When AUTO is selected for an analog output

Normal direction: 4 - 20 mA DC

Reverse direction: 4 - 20 mA DC

- ② When WIDE is selected for an analog output

4 - 20 mA DC is output according to either range No.1 or range No.2, whichever has the wider span.

With pulse output

There is no distinction in output between the normal and reverse directions. The pulse scale is also the same.

The built-in counter simply integrates the flow rate without distinguishing between the normal and reverse directions. However, when normal/reverse differential flow integration is selected, the integration of the "-" direction (subtraction) is available.

Example: In the normal direction

-100 → -99 → -98 ... 0 → 1, 2, 3

In the reverse direction

100 → 99 → 98 ... 0 → 1, 2, 3

With indication

With a reverse flow rate, the "-" symbol will appear on the flow rate display.

When there is a pulse output, it is possible to select the normal/reverse differential flow integration function.

Contact input

Range switching command contact input

Normal direction: when opened

Reverse direction: when closed

Contact output (select the function required.)

Normal/reverse distinction status signal

The contact output status at shipment is as follows.

Range No.1: Open

Range No.2: Closed

Reverse setting is also possible.

"Built-in Counter Function"

- X: Not activated (No pulse output)
 - A: Addition counter
In the normal/reverse range, addition is performed in the normal and reverse directions, respectively.
 - B: Addition counter with preset
The preset value ranges from 0000000000 - 9999999999.
In the normal/reverse range, addition is made in the normal and reverse directions, respectively.
 - C: Normal/reverse differential flow rate integration display
Displays the difference in integration between the normal and reverse directions.
It is necessary to determine the direction: normal or reverse.
-

"Contact Input Function"

This function can be set when either 1- or 2-contact input has been selected in the additional specifications.

X: Not activated

1: External 0% lock input

Used to completely halt the flow rate signal (display, analog output, or pulse output) at 0%.

2: External auto zero adjustment input

Enables zero adjustment from a remote location.

Zero adjustment is possible when the contact is ON for 0.2 seconds or more.

When the contact is ON for 15 seconds or more, the status will become ON again.

Be sure to stop the fluid.

3: External range switching input

Range No.1 or normal direction: when opened

Range No.2 or reverse direction: when closed

4: Built-in counter reset input

Effective when there is a pulse output.

Reset will take effect when the contact is ON for 0.2 seconds or more, and counting will start from the counter reset value at the moment when the contact turns OFF.

5: External 0% lock input and external auto zero adjustment input

Terminal ST IN1 can be set to external 0% lock input and terminal ST IN2 to external auto zero adjustment input.

6: External 0% lock input and external range switching input

Terminal ST IN1 can be set to external 0% lock input and terminal ST IN2 to external range switching input.

7: External 0% lock input and built-in counter reset input

Terminal ST IN1 can be set to external 0% lock input and terminal ST IN2 to the built-in counter reset input.

8: External auto zero adjustment input and external range switching input

Terminal ST IN1 can be set to external auto zero adjustment input and the terminal ST IN2 to external range switching input.

9: External auto zero adjustment input and built-in counter reset input

Terminal ST IN1 can be set to auto zero adjustment input and terminal ST IN2 to built-in counter reset input.

A: External range switching input and built-in counter reset input

Terminal ST IN1 can be set to external range switching input and terminal ST IN2 to built-in counter reset input.

"Contact Output Function"

This function can be set when 1- or 2-contact output has been selected in the additional specifications.

X: Not activated

1: Alarm contact output

An alarm is output when any of the following items becomes abnormal. The abnormal item can be checked on the display inside the instrument. Also, external confirmation is available using the S-SFC.

① Self-diagnostic

- Coil disconnection
- ROM error
- RAM error
- NVM error
- ADC error

Output selection

Mode selection	Burn-out high (HIGH)	Hold (HOLD)	Burn-out low (LOW)
Analog output 4 - 20mA DC	Burn-out high (HIGH) Without SFC communication: 24 mA DC With SFC communication: 23.8 mA DC	Hold (HOLD)	Burn-out low (LOW) Without SFC communication: 0.8 mA DC With SFC communication: 2.96 mA DC
Pulse output	—	Hold (HOLD)	Burn-out low (LOW)
Contact output	Abnormal status (Open/closed can be freely selected.)		

Caution

- If the power supply is turned OFF with the "Burn-out high" setting, the 4 - 20 mA DC output will emit a burn-out high output once. Pay close attention when turning the power supply OFF.

Continued on next page

"Contact Output Function" Continued

② Empty detection function

When the detector becomes empty of the measured fluid, the respective output signals will be as follows.

Output signal \ Status	When the detector is empty of fluid
Analog output 4 - 20 mA DC	4mA DC
Pulse output	0%
Contact output	Abnormal status (Open/closed can be freely selected.)

However, this function can be used when the conductivity is 150 $\mu\text{S}/\text{cm}$ (equivalent to that of water) or higher. The empty detection function selector switch determines whether this function is activated or not. (The empty detection function is set to "NOT activated" at shipment.)

Note: Using the empty detection function with a conductivity of 150 $\mu\text{S}/\text{cm}$ or less will cause a measurement error (minus).

2: Range switching output

The contact output status at shipment is as follows.

Range No.1 or normal direction: Open

Range No.2 or reverse direction: Closed

Reverse setting is also possible.

3: Counter preset status output

Activated when the counter reaches the preset value.

4: Self-check result output

Activated only when a self-diagnostic abnormality occurs in the alarm contact output of code 1.

5: Empty detection function

Activated only when an empty status is detected in the alarm contact output of code 1.

6: High/low limit alarm

Activated only when a high/low limit alarm occurs in the alarm contact output of code 1.

7: Alarm contact output and range switching output (2-contact output)

The alarm contact output can be set to ST.OUT1 and the range switching output to ST.OUT2.

8: Self-diagnostic result output and range switching output (2-contact output)

The self-diagnostic result output can be set to ST.OUT1 and the range switching output to ST.OUT2.

9: Empty detection function and range switching output (2-contact output)

The empty status detection output can be set to ST.OUT1 and the range switching output to ST.OUT2.

Continued on next page

"Contact Output Function" Continued

- A: High/low limit alarm and range switching output (2-contact output)
The high/low limit alarm can be set to ST.OUT1 and the range switching output to ST.OUT2.
- B: Range switching output and counter preset status output (2-contact output)
The range switching output can be set to ST.OUT1 and the preset status output to ST.OUT2.
- C: Range switching output and (self-check result output or empty detection) (2-contact output)
The range switching output can be set to ST.OUT1 and the output when either a self-check result or empty detection abnormality occurs to ST.OUT2.
- D: Alarm contact output and counter preset status output (2-contact output)
The alarm contact output can be set to ST.OUT1 and the counter preset status output to ST.OUT2.
- E: 2-stage flow rate alarm output
The high/low limit alarm can be set to ST.OUT1 and the 2-stage high limit alarm or 2-stage low limit alarm to ST.OUT2.

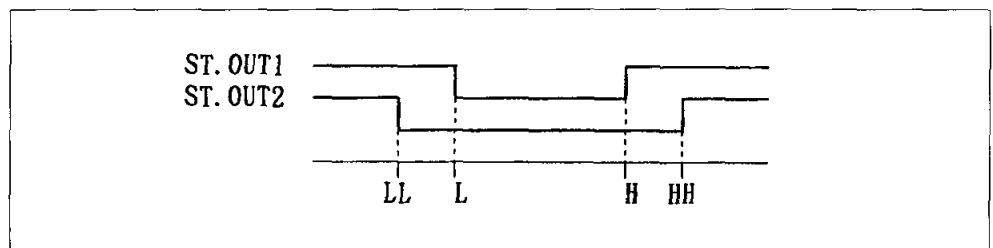

Detector Data Setup

Introduction











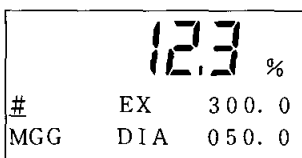

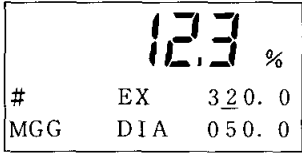

This is used to set and select the constant, model, and diameter of the detector to be used in combination with the converter.

Default setting

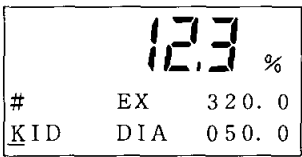
When there is no detector setting, EX300.0, MGG, DIA 050.0 will be selected.

Note:

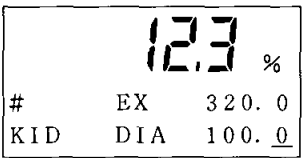
- When you purchase the converter and detector in combination, your converter will contain the detector data that was set during actual flow calibration. Take care not to change the data, or the flowmeter output will be incorrect. Refer to Table 4-1.

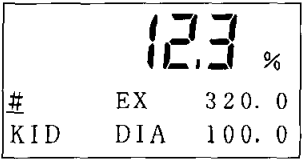
Step	Procedure	Screen
1	Open the detector data setup screen by following the steps to enter the Engineering Mode.	
2	Touch the  key to set the detector constant. Use the  and  keys to input the numerical value printed on the EX column of the detector nameplate.	
3	Touch the  key to select the type of detector. Use the  and  keys to select the model number printed on the nameplate of the detector to be used.	
4	Touch the  key to select the diameter. Use the  and  keys to select the diameter of the detector to be used.	
5	Use the  key to move the cursor to the "#".	

Continued on next page

Detector Data Setup Continued

Default setting
(continued)

Table 4-1 Converter and detector combinations

○: Can be used

Diameter / Detector model No.	MGG	KID	NNM	NNK
2.5	○	○		
5.0	○	○		
10.0	○	○		
15.0	○	○		
25.0	○	○	○	
40.0	○	○	○	
50.0	○	○	○	○
65.0	○			
80.0	○	○	○	
100.0	○	○	○	○
125.0	○			
150.0	○	○	○	
200.0	○	○	○	○
250.0	○	○	○	
300.0	○	○	○	
350.0	○	○	○	
400.0	○	○	○	○
450.0	○			
500.0	○	○	○	
600.0	○	○	○	○
700.0	○		○	
800.0	○			
900.0	○			○
1000.0	○			
1100.0	○			

Note:

- The method for setting the excitation current value (EX value) depends on the detector model number. For models MGG and KID, input the value indicated on the nameplate into the converter. For models NNM and NNK, contact Yamatake Corporation sales personnel when you need to change the setting. Missetting will cause errors and equipment damage.

Setting the Number of Dummy Detectors

Introduction

This is used to set the number of dummy detectors installed with the NNK detector (selected in the detector data setting) (page 4-37).







This screen appears only for underwater electromagnetic flowmeter NNK.

Default setting

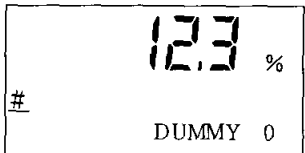
0

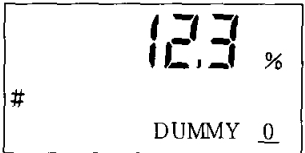
Setting range

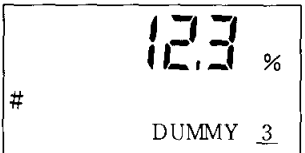
0 - 9

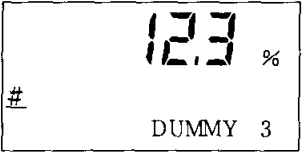
Step	Procedure	Screen
1	Open the dummy detector setup screen by following the steps to enter the Engineering Mode.	
2	Touch the  key once.	
3	Use the  and  keys to input the number of dummy detectors. In this example, the number of the dummy detectors has been changed from 0 to 3.	
4	Touch the  key once to move the cursor to the "#".	

Setting the Range











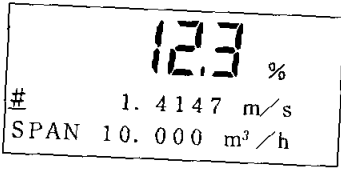

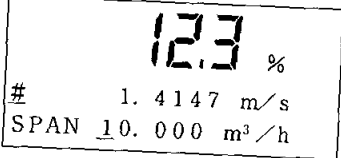

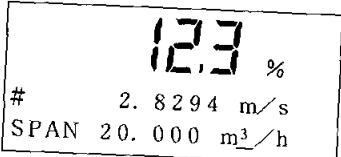
Introduction

This is used to set the flow rate measurement range, which means the value when the electromagnetic output reaches 100%. The lower limit of the range is zero.

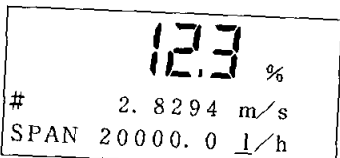
Setting the range

Flow rate: 0.0001 - 99999
 Units: m³, l, cm³, t, kg, g
 Time units: s, min., h, d

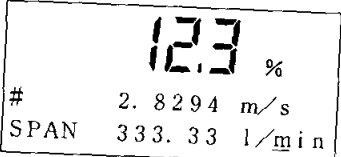
When single range is selected

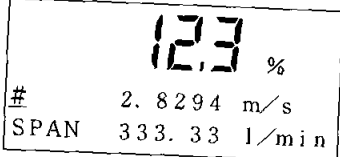
Step	Procedure	Screen
1	Open the range setup screen by following the steps to enter the Engineering Mode.	
2	Touch the  key to move the cursor to the desired digits.	
3	Use the  and  keys to change the numbers.	
4	Touch the  key to move the cursor to the time unit. Use the  or  key to select the desired unit.	
5	Touch the  key to move the cursor to the flow rate unit. Use the  or  key to select the desired unit.	
6	Touch the  key to move the cursor to the "#".	

Setting Hysteresis

Introduction







This is used to set the hysteresis as a range function to be used at range switching. Use for normal direction automatic double range or the normal/reverse direction automatic double range.

Default setting

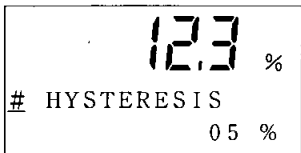
0

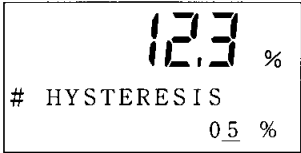
Setting range

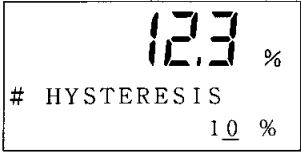
0 - 20%

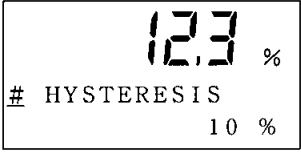
Step	Procedure	Screen
1	Open the hysteresis setup screen by following the steps to enter the Engineering Mode.	
2	Touch the  key once.	
3	Use the  and  keys to input the desired hysteresis value. In this example, here the hysteresis is changed from 5% to 10%.	
4	Touch the  key to move the cursor to the "#".	

Selecting the Current Output Method

Introduction

This is used as a range function with the normal direction double range or normal/reverse direction double range, to select how to output the 4 - 20 mA analog output: with either the range switching method or the wider range method.

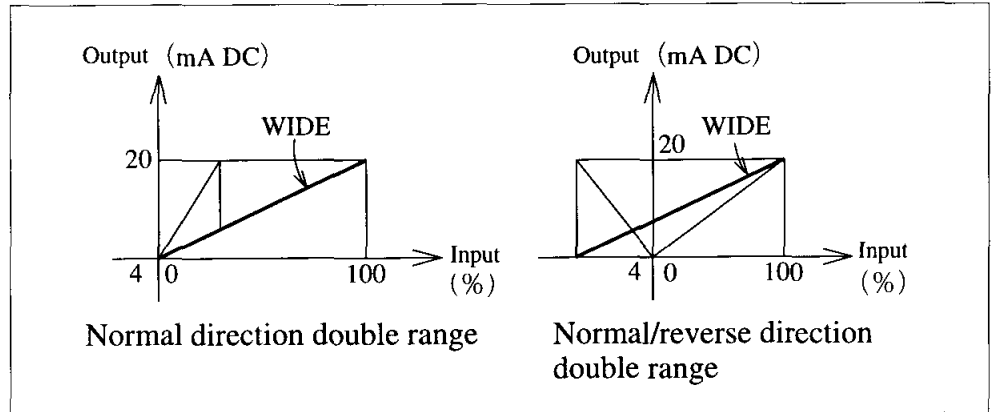

Default setting

AUTO

Setting the range

Either AUTO or WIDE.

Step	Procedure	Screen
1	Open the current output method selection screen by following the steps to enter the Engineering Mode.	
2	Touch the key once.	
3	Use the and keys to enter the desired hysteresis value.	
4	Touch the key to move the cursor to the "#".	

Setting the Specific Gravity

Introduction







This is used to set the specific gravity when selecting a weight unit (t, kg, g) in range setting. Without this setting, an output error may result.

Default setting

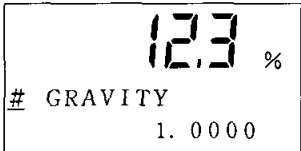
1.0000

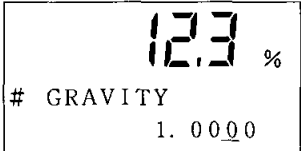
Setting range

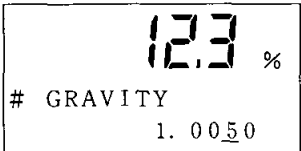
0.1000 - 9.9999

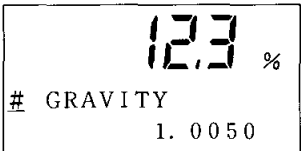





Step	Procedure	Screen
1	Open the specific gravity setup screen by following the steps to enter the Engineering Mode.	 <p>12.3 % # GRAVITY 1.0000</p>
2	Use the  key to move the cursor to the desired numbers.	 <p>12.3 % # GRAVITY 1.00<u>0</u>0</p>
3	Use the  and  keys to change the figures.	 <p>12.3 % # GRAVITY 1.00<u>5</u>0</p>
4	Touch the  key to move the cursor to the "#".	 <p>12.3 % # GRAVITY 1.0050</p>

Setting/Changing the Coefficient of Compensation

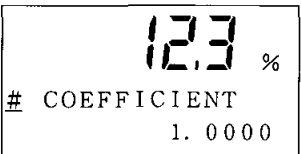
Introduction The coefficient of compensation can be set to multiply the output flow rate as required.

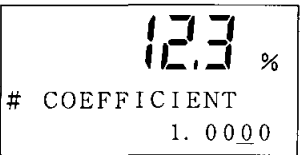
Default setting 1.0000

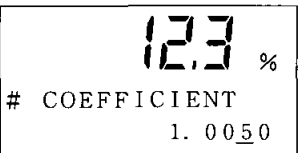
Setting range 0.1000 - 9.9999

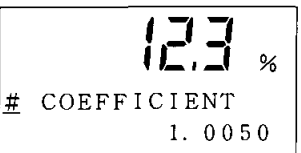
Step	Procedure	Screen
1	Open the compensation coefficient setup screen by following the steps to enter the Engineering Mode.	
2	Use the  key to move the cursor to the desired numbers.	
3	Use the  and  keys to change the figures.	
4	Touch the  key to move the cursor to the "#".	

Setting the Pulse Scale

Introduction

The flow rate per pulse can be set when a pulse output board has been selected (additional specifications). This is used to set the pulse scale so that the frequency on the upper right of the 16-digit display will not exceed 2,000 Hz. When changing the pulse scale with a double range, use the wider range.

Default setting

100.00 cm³/p

Setting range

Within the range where the frequency will not exceed 2000 Hz
Unit: m³, l, cm³, t, kg, g

Step	Procedure	Screen
1	Open the pulse scale setup screen by following the steps to enter the Engineering Mode.	
2	Use the key to move the cursor to the desired numbers.	
3	Use the and keys to change the figures.	
4	Touch the key to move the cursor to the "#".	

Setting the Pulse Width

Introduction

The pulse width that will be output from the pulse output terminal can be set when a pulse output board has been selected. This is used to set the pulse width so that the duty ratio at the upper right of the 16-digit display will not exceed 70%.

When changing the pulse width with a double range, use the wider range.

Default setting

NUM 010.00

Setting range

Pulse width: "NUM", "DUTY"

Pulse width: 000.00 - 999.99 ms

When "NUM" is selected, the pulse width can be set freely.

When "DUTY" is selected, "DUTY" is fixed at 50%.

Step	Procedure	Screen
1	Open the pulse width setup screen by following the steps to enter the Engineering Mode.	<p>12.3 % # PLS 27.778 % WID NUM 010.00ms</p>
2	Use the key to move the cursor to "NUM".	<p>12.3 % # PLS 27.778 % WID <u>NUM</u> 010.00ms</p>
3	By touching the key, the screen used to enter a numerical value pulse width will change to the screen used to fix the duty ratio at 50%.	<p>12.3 % # PLS WID <u>DUTY</u> 50%</p>
4	To enter the pulse width using a numerical value, return to the numerical value entry screen by using the key, and move the cursor to the desired digits using the key.	<p>12.3 % # PLS 27.778 % WID NUM 0<u>1</u>0.00ms</p>
5	Use the and keys to change the numbers.	<p>12.3 % # PLS 13.889 % WID NUM 00<u>5</u>.00ms</p>
6	Touch the key to move the cursor to the "#".	<p>12.3 % # PLS 13.889 % WID NUM 005.00<u>#</u>ms</p>

Setting the Drop-out

Introduction

A drop out is set to prevent incorrect integration of the flow rate. Pulse counting will pause when the flow rate is at the preset percentage of the set range.

Default setting

2%

Setting range

0 - 10%

Step	Procedure	Screen
1	Open the drop out setup screen by following the steps to enter the Engineering Mode.	
2	Touch the key.	
3	Use the and keys to change the number.	
4	Touch the key to move the cursor to the "#".	







Setting High and Low Limit Alarms

Introduction An alarm is output when the instantaneous percent flow rate exceeds the pre-set high and low limits.

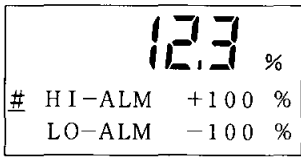
Important This function can be used when the high/low limit alarm is selected in the contact output function.

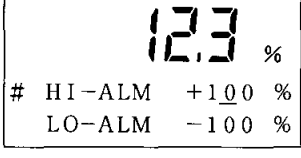
Default setting HI-ALM +100% LO-ALM +100%

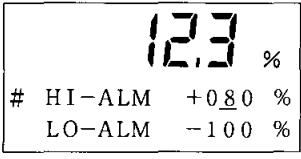
Setting range HI-ALM -115 - +115% LO-ALM -115 - +115%

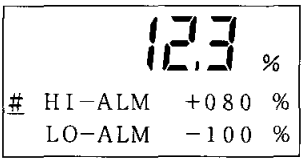
Step	Procedure	Screen
1	Open the high and low limit alarm setup screen by following the steps to enter the Engineering Mode.	 <p>12.3 % # HI-ALM +100 % LO-ALM -100 %</p>
2	Use the  key to move the cursor to the desired digit.	 <p>12.3 % # HI-ALM +100 % LO-ALM -100 %</p>
3	Use the  and  keys to change the numbers.	 <p>12.3 % # HI-ALM +080 % LO-ALM -100 %</p>
4	Touch the  key to move the cursor to the "#".	 <p>12.3 % # HI-ALM +080 % LO-ALM -100 %</p>

Setting a 2-stage Flow Rate Alarm

Introduction

A first alarm will be output when the instantaneous percent flow rate exceeds the preset first high or low limit. A second alarm will be output when the flow rate exceeds the second high or low limits.

Important

This function can be used when the 2-stage high/low limit alarm is selected in the contact output function.

Default setting







HI-ALM1, HI-ALM2 +100%

LO-ALM1, LO-ALM2 -100%

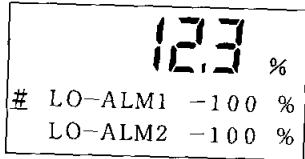
Setting range

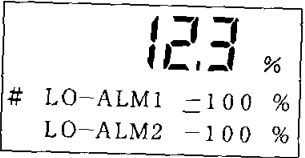
HI-ALM1, HI-ALM2 -115 - +115%

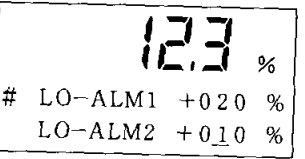

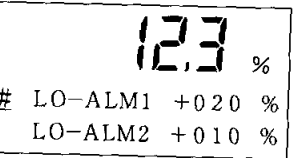



LO-ALM1, LO-ALM2 -115 - +115%

Step	Procedure	Screen
1	Open the 2-stage high/low limit alarm setup screen by following the steps to enter the Engineering Mode.	
2	Use the  key to move the cursor to the desired digits.	
3	Use the  and  keys to change the numbers.	
4	Touch the  key to move the cursor to the "#".	

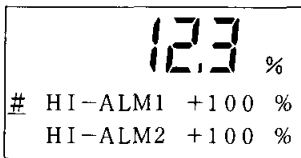
Continued on next page

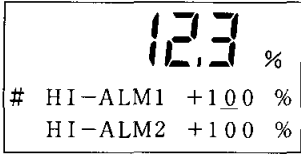
Setting a 2-stage Flow Rate Alarm Continued

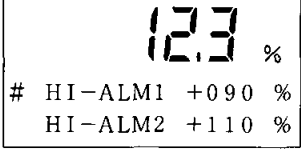
Setting the flow rate alarm (Continued)

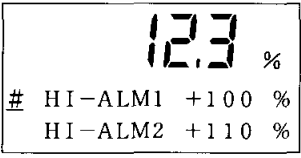
Step	Procedure	Screen
5	Touch the  key to set the 2-stage high limit alarm in the same way.	
6	Use the  key to move the cursor to the desired digits.	
7	Use the  and  keys to change the numbers.	
8	Touch the  key to move the cursor to the "#".	

Setting the Low Flow Cut

Introduction









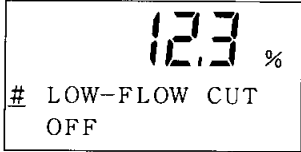

When the fluid flow inside the detector is narrow, the fluid is regarded as stationary and the analog output can be latched to zero. The value at which to cut the flow in this situation is referred to as the "low flow latch."

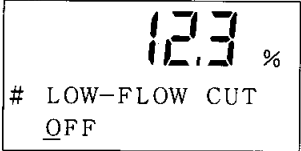
Default setting

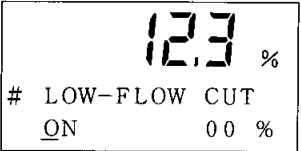
OFF

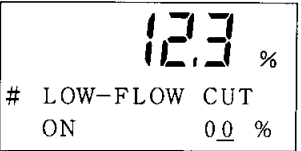
Setting range

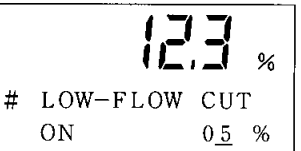
OFF or ON 0% - ON 10%

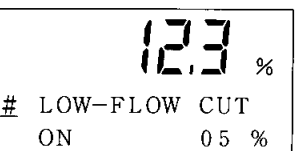
Step	Procedure	Screen
1	Open the low flow cut setup screen by following the steps to enter the Engineering Mode.	
2	Touch the  key.	
3	By touching the  key, the "OFF" message will change to "ON". Now you can enter the low flow cut in a numerical value.	
4	Touch the  key, and the cursor will moves to the numerical figures.	
5	Use the  and  keys to select the desired numbers.	
6	Touch the  key to move the cursor to the "#".	

Determining the Pulse Output Abnormality Treatment Direction

Introduction

It is possible to determine the pulse output direction when an abnormality occurs in the electromagnetic flowmeter and flow rate measurement becomes impossible. Use this function when pulse output is selected.

Caution

- The abnormality treatment direction is very important for securing the safety of the overall control process. Determine the treatment direction very carefully. Otherwise the equipment will be damaged.







Default setting

"LOW"

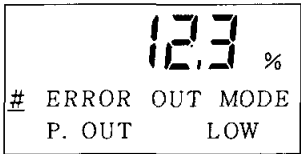
Setting range

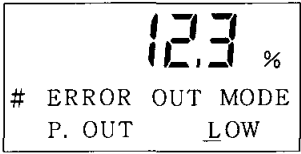
"LOW": Outputs no pulse.

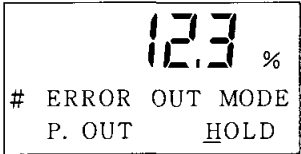
"HOLD": Holds the pulse to the value obtaining just before the abnormality occurred.

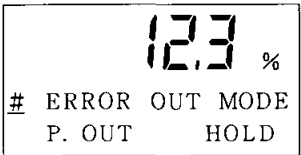
Step	Procedure	Screen
1	Open the pulse output abnormality treatment direction setup screen by following the steps to enter the Engineering Mode.	
2	Touch the  key.	
3	Use the  or  key to determine the abnormality treatment direction.	
4	Touch the  key to move the cursor to the "#".	

Determining the Analog Output Abnormality Treatment Direction

Introduction

It is possible to determine the analog output direction when an abnormality occurs in the electromagnetic flowmeter and flow rate measurement becomes impossible.

Caution

- The abnormality treatment direction is very important for securing the safety of the overall control process. Determine the treatment direction very carefully. Otherwise the equipment will be damaged.

Default setting







"LOW"

Setting range

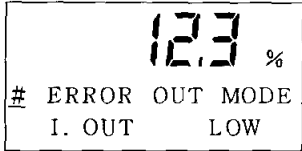
"LOW": Minimizes the output.

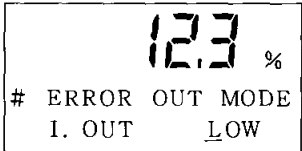
"HIGH": Maximizes the output.

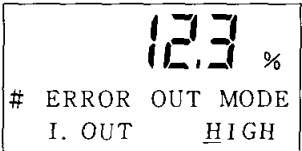
"HOLD": Holds the pulse to the value obtaining just before the abnormality occurred.

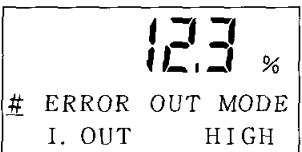
Step	Procedure	Screen
1	Open the analog output abnormality treatment direction setup screen by following the steps to enter the Engineering Mode.	
2	Touch the  key.	
3	Use the  and  keys to determine the abnormality treatment direction.	
4	Touch the  key to move the cursor to the "#".	

Setting the Contact Output Status

Introduction

This is used to set the contact output status for normal operation.

Important

This function is displayed when contact output has been selected (additional specification).







Default setting

"CLOSE"

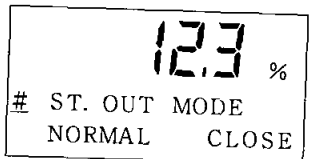
Setting range

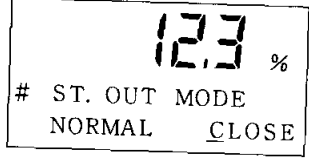
"CLOSE" "OPEN"

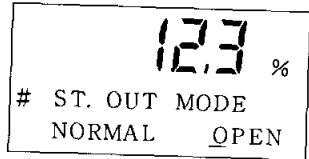
For 1-contact input and 1-contact output

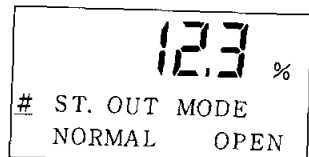
Step	Procedure	Screen
1	Open the contact output status setup screen by following the steps to enter the Engineering Mode.	
2	Touch the  key.	
3	Use the  key to set the contact output status.	
4	Touch the  key to move the cursor to the "#".	

(Continued on next page)

Setting the Contact Output Status Continued

Setting range
(continued)

<For 2-contact output>

Step	Procedure	Screen
1	Open the contact output status setup screen by following the steps to enter the Engineering Mode.	<p>12.3 % # ST. OUT1 MODE NORMAL CLOSE</p>
2	Touch the key.	<p>12.3 % # ST. OUT1 MODE NORMAL <u>C</u>LOSE</p>
3	Use the key to set the contact output status.	<p>12.3 % # ST. OUT1 MODE NORMAL <u>O</u>PEN</p>
4	Touch the key to move the cursor to the "#".	<p>12.3 % # ST. OUT1 MODE NORMAL OPEN</p>
5	Touch the key to set contact output 2 in the same way.	<p>12.3 % # ST. OUT2 MODE NORMAL CLOSE</p>

Maintenance Mode

Introduction

The Maintenance Mode includes the following adjustments and items to be checked. Refer to Chapter 6 for the operating method.

OUTPUT CHECK MODE

Screen display	Description	Indication conditions
OUTPUT CHECK I.OUT	Checks the analog output loop	
OUTPUT CHECK P.OUT	Checks the pulse output loop	Selection of pulse output.
ST.IN OPEN ST.OUT CLOSE	Checks the contact input/output loop	Selection of 1-contact input and 1-contact output (additional specification).
ST.IN1 OPEN ST.IN2 OPEN	Check the 2-contact input loop	Selection of 2-contact input (additional specification).
ST.OUT1 CLOSE ST.OUT2 CLOSE	Checks the 2-contact output loop	Selection of 2-contact output (additional specification).
EX CHECK	Check the excitation source.	

CALIBRATION MODE

Screen display	Description	Indication conditions
CAL EX	Adjusts the excitation current	
CAL I.OUT	Adjusts the analog output	
CAL GAIN	Adjusts the converter gain	

CRITICAL MODE

Screen display	Description	Indication conditions
ROM VER.	Checks the ROM version	
ERROR HISTORY	Checks the error history	
SHIPPING DATA RECOVERY	Restores the internal data to the status at shipment	
INITIAL DATA RECOVERY	Initializes the internal data	

Chapter 5 - Maintenance and Troubleshooting of the Electromagnetic Flowmeter

Outline of this chapter

This chapter describes the maintenance and inspection procedures for the electromagnetic flowmeter and the information that should be referred to during troubleshooting.

First, this chapter explains the procedures used to check the converter functions. The items to be checked are as follows.

- Input/output signal loop check
 - Analog output
 - Pulse output
 - Contact input/output
 - Excitation current
- False signal input by the calibrator

These items serve to aid in early detection of the causes of abnormalities in converter operation.

This chapter also explains the troubleshooting procedures and the initial data recovery procedures.

When using the S-SFC (either Japanese or English display) refer to the user's manual CM1-MGG000-2001 or CM2-MGG000-2001.

5.1 Checking Functions

Checking the Input/Output Signal Loop

Introduction

The converter includes a constant current generator. Current from 0% to 115% of the flow rate signal can be set. Loop checking can be performed with this function, as can loop checking of the pulse output and contact input/output. This function can be executed in the Maintenance Mode.

Occasion

Use this function to check wiring and the operation of the equipment connected to the converter in the measuring loop.

Type

These are the items used for the loop check.







- Analog output
 - Pulse output
 - Contact input/output
 - Excitation current
-

Checking the Analog Output

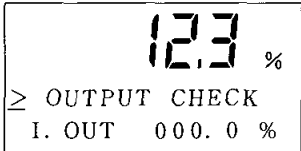
Introduction The analog output can be checked by using the electromagnetic flowmeter as a constant current generator.

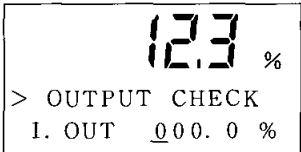
Default setting Display current output

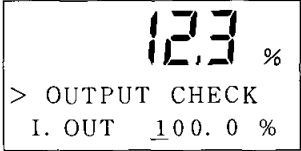
Setting range 000.0% - 115.0% (the percentage is the ratio of the preset range.)

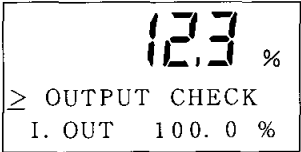





Step	Procedure	Screen
1	Open the analog output check screen by following the steps to enter the Maintenance Mode.	 <p>12.3 % > OUTPUT CHECK I. OUT 000.0 %</p>
2	Touch the  key to move the cursor to the numerical figure to be checked. In this situation, the current corresponding to the percentage of the preset I.OUT will be output.	 <p>12.3 % > OUTPUT CHECK I. OUT <u>0</u>00.0 %</p>
3	Using the  and  keys, change the percentage to the desired one. In the example at right, an analog output of 100% of the range (20 mA) is output.	 <p>12.3 % > OUTPUT CHECK I. OUT <u>1</u>00.0 %</p>
4	Touch the  key to move the cursor to ">." The analog output will return to the value corresponding to the percentage of the actual flow rate indicated on the main display.	 <p>12.3 % > OUTPUT CHECK I. OUT 100.0 %</p>

Checking the Pulse Output

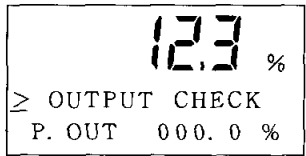
Introduction The pulse output can be checked by using the electromagnetic flowmeter as a constant current generator.
This screen will appear if pulse output has been selected (additional specification).

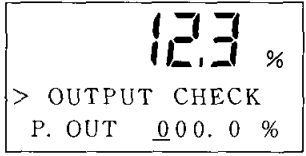
Default setting Display current output

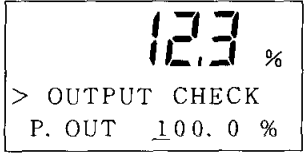
Setting range 000.0% - 115.0%

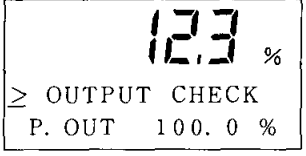
Step	Procedure	Screen
1	Open the pulse output check screen by following the steps to enter the Maintenance Mode.	 <p>12.3 % ≥ OUTPUT CHECK P. OUT 000.0 %</p>
2	Touch the  key to move the cursor to the numerical figure to be checked. In this situation, the pulse of the frequency corresponding to the indication will be generated.	 <p>12.3 % > OUTPUT CHECK P. OUT <u>0</u>00.0 %</p>
3	Using the  and  keys, change the percentage to the desired one. In the example at right, a pulse of the frequency corresponding to a flow rate of 100% will be generated.	 <p>12.3 % > OUTPUT CHECK P. OUT <u>1</u>00.0 %</p>
4	Touch the  key to move the cursor to “>.” The pulse will be generated according to the indication on the large 7-segment flow rate display.	 <p>12.3 % ≥ OUTPUT CHECK P. OUT 100.0 %</p>

Checking the Contact Input/Output Loop

Introduction







Check the contact input terminal status on the LCD by turning ON/OFF the contact input terminal of the electromagnetic flowmeter.
 It is also possible to check the loop of the contact output signal by turning ON/OFF the contact output terminal of the electromagnetic flowmeter.
 The screen that will be displayed depends on what contact input/output functions have been selected (additional specification).

Default setting

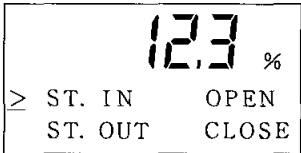
Display current status

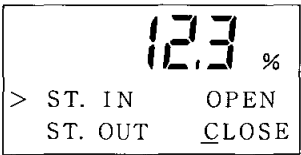
Setting range

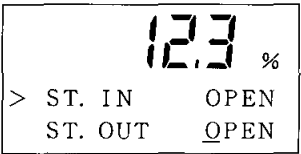
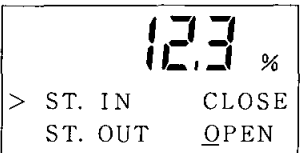
“CLOSE” “OPEN”

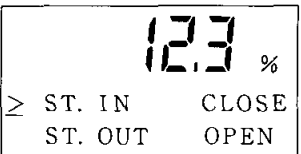
	Procedure	Screen
1	Open the contact input/output loop check screen by following the steps to enter the Maintenance Mode.	
2	Touch the  key to move the cursor to the “CLOSE” or “OPEN” that indicate the status of ST.OUT (abbreviation of contact output).	
3	Using the  key, select the contact output status to be checked. While this screen is being displayed, the contact status is output as indicated.	
4	While this screen is being displayed, the indication of OPEN or CLOSE will change according to the contact input terminal status.	
5	Touch the  key to move the cursor to “>”.	

Continued on next page





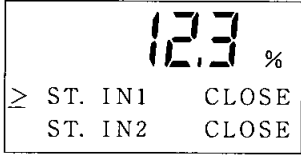
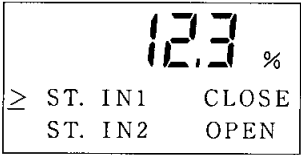

Checking the Contact Input/Output Loop Continued

Setting range
(continued)

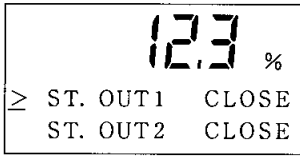
When 2-contact input is selected

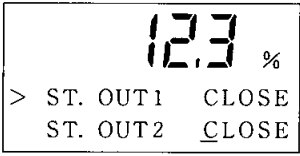
Step	Procedure	Screen
1	Open the contact input loop check screen by following the steps to enter the Maintenance Mode.	 <p>12.3 % ≥ ST. IN1 CLOSE ST. IN2 CLOSE</p>
2	There is no cursor movement on this display. The indication of OPEN or CLOSE will change depending on the connected contact input terminal status.	 <p>12.3 % ≥ ST. IN1 CLOSE ST. IN2 OPEN</p>

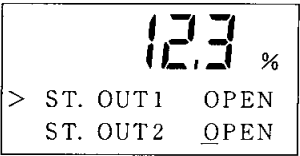
When 2-contact output is selected

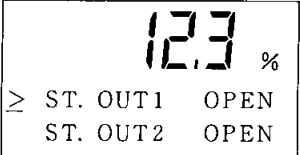





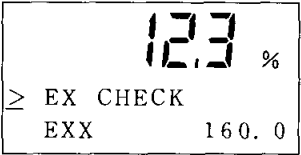

Step	Procedure	Screen
1	Open the contact output loop check screen by following steps to enter the Maintenance Mode.	 <p>12.3 % ≥ ST. OUT1 CLOSE ST. OUT2 CLOSE</p>
2	Touch the  key to move the cursor to the "CLOSE" or "OPEN" that indicates the contact output status.	 <p>12.3 % > ST. OUT1 CLOSE ST. OUT2 <u>CLOSE</u></p>
3	Using the  key, select the contact output status to be checked. The two contact output terminals close or open simultaneously. While this screen is being displayed, the contact status is output as indicated. It is impossible to change the status of only one contact output terminal.	 <p>12.3 % > ST. OUT1 OPEN ST. OUT2 <u>OPEN</u></p>
4	Touch the  key to move the cursor to ">."	 <p>12.3 % ≥ ST. OUT1 <u>OPEN</u> ST. OUT2 OPEN</p>

Checking the Excitation Current

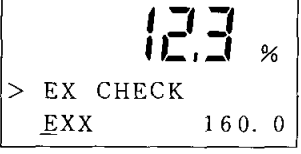
Introduction

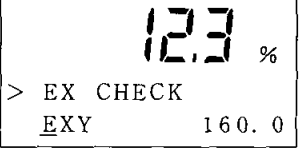
It is possible to check the excitation current value that flows into the coil in the detector and its flow direction.

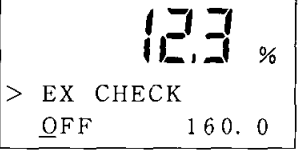
This check is not possible for integral models.

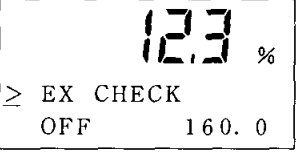
Step	Procedure	Screen
1	Open the excitation current check screen by following the steps to enter the Maintenance Mode. In this situation, the multimeter output will not be stable since the excitation current is flowing rectangularly.	 <p>12.3 % > EX CHECK EXX 160.0</p>
2	Touch the  key once, and the excitation current will be a direct current and will flow from X to Y. Make sure the current reaches 160.0 mA.	 <p>12.3 % > EX CHECK EXX 160.0</p>
3	Touch the  key again, and the current will flow from Y to X. The polarity will be the reverse of the status in Step 2.	 <p>12.3 % > EX CHECK EXY 160.0</p>
4	Touch the  key again, and the excitation current will stop.	 <p>12.3 % > EX CHECK OFF 160.0</p>
5	Finally, touch the  key again to move the cursor to ">".	 <p>12.3 % > EX CHECK OFF 160.0</p>

False Signal Input by Calibrator

Introduction	The electromagnetic flowmeter is provided with a dedicated calibrator, which has the function of generating the same signal as the flow rate signal from the detector. The converter function can be checked using this false signal.
When to use	When a problem occurs in the converter, use this method to judge whether detector or the converter is responsible for the problem.
Preparation	<p>Prepare the following equipment.</p> <ul style="list-style-type: none">• Dedicated calibrator and dedicated cable• Digital voltmeter• Resistor (250Ω) <p>In addition, the value of the measuring span is needed as data to be input into the dedicated calibrator.</p>
How to check	Calibrate the electromagnetic flowmeter according to the calibrator's operating manual. The code of the calibrator's operating manual is CM2-MGZ100-2001.

5-2 Troubleshooting

Overview

Introduction

If a problem occurs at electromagnetic flowmeter start-up and operation, the following three causes should be considered.

- Inconsistency between the electromagnetic flowmeter's specifications and the actual operating conditions
- Missetting or misoperation
- Electromagnetic flowmeter malfunction

If a problem occurs during electromagnetic operation, the converter's self-diagnostic function will classify it as serious or minor. It will indicate this and respond accordingly.

Perform the proper correction measures, referring to the troubleshooting guidelines described in this section.

Serious trouble

Serious problems may obstruct electromagnetic flowmeter operation and finally damage the flowmeter, if not corrected. When serious trouble occurs during electromagnetic flowmeter operation, an error message will appear on the converter's display panel and the flowmeter will continue to output the preset value in the abnormality treatment (fail-safe) direction. The error message and the self-diagnostic results will be visible on the display panel or using the S-SFC's STAT (diagnosis) key.

Example:

EX CHECK ERROR: This message appears if the detector coil has been disconnected.

Minor trouble

Minor problems will not seriously obstruct electromagnetic flowmeter operation. When an error occurs during electromagnetic flowmeter operation and is regarded as a minor problem by the converter self-diagnostics, the output will not burn out and the electromagnetic flowmeter will continue to output the instantaneous flow rate.

Errors at Start-up

Troubleshooting

When a problem occurs at start-up, perform the following procedures. If the problem remains, it is possible that the electromagnetic flowmeter has been damaged. Contact the reference listed on the last page of this manual.

Trouble	Check points and treatment
No indication on display panel at power-up.	<ul style="list-style-type: none"> • Check the converter power supply specification. • Make sure the ambient temperature is not below -25°C.
No output at power-up.	<ul style="list-style-type: none"> • Make sure the signal line is correctly connected.
No communication with S-SFC.	<ul style="list-style-type: none"> • Make sure the main card switches have the following settings. <div data-bbox="964 840 1207 963" data-label="Diagram"> </div> <ul style="list-style-type: none"> • Make sure the signal line is correctly connected. • Make sure the S-SFC is correctly connected. • Make sure the S-SFC is Version 7.0 or later. Some functions will not work on other versions.
No pulse output.	<ul style="list-style-type: none"> • Make sure the pulse output line is correctly connected. • Make sure pulse output has been selected in the converter specification.
Current output remains 0 mA.	<ul style="list-style-type: none"> • Make sure the power supply and voltage are correct. • Make sure the main card switches have the following settings. <div data-bbox="964 1568 1207 1691" data-label="Diagram"> </div>

Errors during Operation

Troubleshooting

When a problem occurs during operation, perform the following procedures.

1. Check against the table on this page for symptoms of the error. If found, perform the steps indicated in the table.
2. When communication with S-SFC is used, read the error message and the self-diagnostic result using the STAT (diagnosis) key.
3. When the problem cannot be solved, it is possible that the electromagnetic flowmeter has been damaged. Contact the reference listed on the last page of this manual.

Trouble	Check points and treatment
Output fluctuates excessively beyond the estimated flow rate range.	<ul style="list-style-type: none"> • Make sure the electromagnetic flowmeter is correctly grounded. • Make sure the damping time constant is set correctly. • Clean the electrodes.
Output exceeds 100%.	<ul style="list-style-type: none"> • Make sure the set range is set correctly. • Make sure the span is set correctly. • Make sure the zero point is correctly adjusted. • Make sure the converter is correctly calibrated.
Output remains 0%.	<ul style="list-style-type: none"> • Make sure the pipe is not empty. If it is empty, the empty detection function will be functioning. • Make sure the signal line is correctly connected. • Make sure the valves are open on the upper and lower sides. • Make sure the span is set correctly. • Make sure the converter is not in the constant current mode. • Make sure the flow rate is not in the low flow cutoff range.

Continued on next page

Errors during Operation Continued

Troubleshooting (continued)

Trouble	Check points and treatment
Output has burnt out.	<ul style="list-style-type: none">• Refer to “Error messages and treatment” to perform measures.
Pulse output is too large or too small for the flow rate.	<ul style="list-style-type: none">• Make sure the pulse scale and width are correctly set.• Make sure the converter is correctly calibrated.• Make sure the pulse counter specification is proper.• Make sure the drop out value is correctly set between 0 and 10%.

Error Messages and Treatment (Display)

Hardware check

Hardware check is executed in the Measuring Mode.

Perform the proper measures immediately.

While an error code (Err-01 to Err-05) is being displayed, the output for the abnormal situation will be as preset in the Engineering Mode.

Error codes for serious trouble

Err-01
 EX CHECK
 ERROR

Error code	Error contents	Treatment	LCD display
Err-01	Coil disconnected EX open	1. Check connection. 2. Measure coil resistance. 3. Restore power.	EX CHECK ERROR
Err-02	ROM check error	1. Restore power. 2. Replace ROM. 3. Replace main circuit board.	ROM CHECK ERROR
Err-03	RAM READ AFTER WRITE error	1. Restore power. 2. Replace main circuit board.	RAM CHECK ERROR
Err-04	NVM READ AFTER WRITE error	1. Restore power. 2. Replace main circuit board.	NVM CHECK ERROR
Err-05	ADC error A/D change error	1. Restore power. 2. Replace main circuit board.	ADC CHECK ERROR

(Continued on next page)

Error Messages and Treatment (Display) Continued

Checking for mis-setting

Missetting diagnostics are executed in the Engineering Mode. When a setting is incorrect, the error will be displayed for one second and then the incorrectly-set screen will appear.
(To view the error contents again, press the MODE key.)

Note: Press the MODE key for more than 5 seconds, and the data will return to the status obtaining before entering the Engineering Mode.

Error codes for minor trouble

Error code	Error contents	Treatment	LCD display
Err-11	Mismatch of diameter and detector type.	Check diameter and detector and enter proper data.	TYPE-DIA MATCHING ERROR
Err-12	High/low limit alarm error. HI>LO	Set HI≥LO.	SETTING ERROR HI<LO
Err-21	Span setting of 12 m/s or more.	Check SPAN, DIA, TYPE, DUMMY settings.	SPAN ERROR OVER 12m/s
Err-22	Pulse frequency too large or too small.	Check 1. pulse scale and 2. pulse frequency settings.	PULSE WEIGHT SETTING ERROR
Err-23	Pulse width too large. DUTY 70% or more at pulse frequency output	Check 1. pulse width 2. pulse scale and 3. span settings.	PULSE WIDTH OVER DUTY 70%
Err-24	Hysteresis exceeding 100% of range in normal/reverse automatic range	Check hysteresis setting.	HYSTERSIS SETTING ERROR

MagneW 3000 FLEX Smart Electromagnetic Flowmeter Converter (General model) MGG10C (Integral/Remote)

Introduction

The MagneW 3000 FLEX electromagnetic flowmeter converter is a high performance, highly reliable flowmeter. Based on Yamatake Corporation's proven MagneW 3000 flow measurement technologies, the MGG10C offers expanded flowrate and process measurement capabilities when used with the new range of MagneW 3000 FLEX detectors.

Special features

- 1) Liquid crystal display with optional backlighting
 - Backlight eases reading in direct sunlight or in a dark room.
 - Simultaneously displays flow volume in %, actual flow volume and integrated flow volume.
 - Rotating display improves visibility of integral models mounted on pipes up to 90° degrees from standard.
- 2) Setting parameters by optional infrared touch sensor
 - Allows sare setting, in severe environments, without opening the cover of the converter.
 - Prevent malfunctioning of the infrared touch sensor via special security feature.
- 3) Easy changeover of integral and remote models
 - One converter case is used for both models.
- 4) Broader range of pitch in cable connection port
 - Allows incorporation of an all-purpose waterproofing gland the pitch of the cable connection port has been significantly increased.
- 5) Compatibility
 - Enables combination of the remote electromagnetic flow converter with conventional detectors. Please talk to your Yamatake Corporation representative for details.

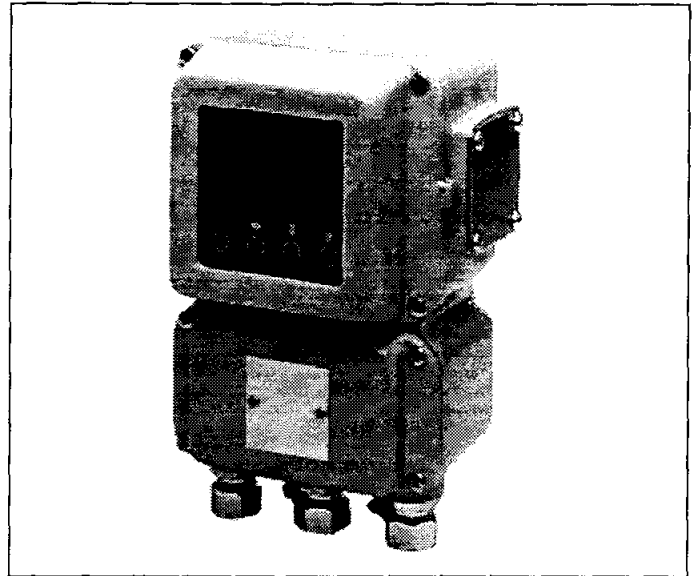

Wide variety of applications

- Pulp and Paper:** Pulp liquids, chemicals, corrosive liquids, industrial water, wastewater, etc.
- Petroleum/petrochemical/chemicals:**
Corrosive liquids, dyestuffs, chemicals, industrial water, waste water, etc.
- Public utilities:** Water supply systems, sewage systems, community drainage, human waste, sludge, sediment slurry, regulation of total effluent, etc.
- Food:** Potable water, light, medium and high density fluids, industrial water, waste water, etc.
- Steel/nonferrous metals/ceramics:**
Alumina slurry, cooling water, industrial water, corrosive liquids, wastewater, etc.
- Machinery/equipment/electric machinery:**
Corrosive liquids, cooking water, circulating water, industrial water, waste water, etc.
- Construction:** Building material slurry, sediment slurry, cement slurry, industrial water, etc.
- Shipbuilding:** Sediment slurry, etc.
- Electric power:** Corrosive liquids, cooling water, industrial water, wastewater, etc.
- Gas:** Circulating water for air conditioning, etc.

Converter specifications (standard)

<Equipment specifications>

Structure: JIS C 0920 Water-proof model

NEMA ICS6-110 TYPE4X

IEC PUBL 529 IP66

Finish: Acrylic resin

Color: Light beige (Munsell 4Y7.2/1.3)

Main body material: Aluminum alloy

Display cover material: Tempered glass, 5mm thick
Aluminum alloy

Main power supply: AC100V, 110V, 115/120V±10%
AC200V, 220V, 230/240V±10%

Frequency: 50Hz or 60Hz
DC24V±10%

Power consumption: Within 13W (17VA)

Input signal:

Flow signal: Flow proportional voltage signal from the detector

Contact input (optional):

Solid-state contact or no-voltage contact

Output signal:

Excitation current:

Output of the excitation current to the detector coil

Analog output: 4 to 20mADC (select digital output)

Digital output: DE (Select analog output)

Contact output (optional):

Open collector

Contact capacity: 30VDC max., 200mA max.

Pulse output (optional):

Open collector

Contact capacity: 30VDC max., 200mA max.

Pulse frequency: 2000Hz max.

Pulse width: 0.3 to 999.9ms

Random setting or fixed at 50% of the duty

Analog output range/load resistance

Without SFC communication:

0.8mA to 22.4mA (-20% to +115%)

Load resistance: 0 to 600 ohm

With SFC communication:

3.2mA to 22.4mA (-5% to +115%)

External power source for SFC communication:

DC16 to 45V

Load resistance (Ω) =

(External power source for communication - 8.5V) /
0.025

Digital output range/load resistance

With SFC communication:

3.2mA to 22.4mA (-5% to +115%)

External power source for SFC communication/

digital communication: DC16 to 45V

Load resistance (Ω) =

(External power source for communication - 8.5V) /
0.025

Display (optional): Indication by LCD with backlighting

Main display: 7-segment, 6 digits

Sub display: 16 digits, 2 lines

Display contents:

Instantaneous indication of flow volume in percentage, instantaneous indication of actual flow volume and indication of integrated flow volume (when pulse output selected)

Selection of main display and secondary display:

Random selection depending on data, three columns maximum.

Data setter (optional):

Setting by means of infrared touch sensor

Infrared touch sensor: four key switches

Unit of flow indication:

Can be selected from between percentage, volume flow, mass flow, time.

Indication of volume flow: m³, ℓ, cm³

Indication of mass flow: t, kg, g

Indication of time: d, h, min, s

Damping time constant:

Continuous variable from 0.5s to 199.9s (time duration until 63.2% of the set range is reached.)

Low flow cutoff:

Output corresponding to 0 to 10% of the set range of the analog output and digital output is fixed at 0% (the integer is a continuous variable.)

Dropout:

Pulse output corresponding to 0 to 10% of the set range of the analog output and digital output is cut (the integer is a continuous variable.)

Lightning protection:

12kV, 1000A

Incorporated into the power source and external input and output terminals.

Power failure:

An EEPROM retains data record of integrated flow volume when pulse output is used (retention period approximately 10 years)

Converter specifications (standard)

Installation specifications

Ambient temperature: -25 to +60°C

Ambient humidity: 5 to 100% RH

Wiring connection port:

G1/2 (PF1/2) internal threads, 1/2 NPT internal threads, CM20 internal threads, Pg 13.5 internal threads

Installation: Integral detector / converter,
Wall mounting, 2B pipe mounting

Grounding: Category 3(Grounding resistance:
lower than 100 Ω)

Mass : 3.7kg

Functions

Functions of built-in counter (optional for pulse output models):

Totalizer:

Depending on the pulse distortion setting, it totals one count at a time, for forward and reverse flows.

Totalizer with presetting function:

A preset value target total can be set between 0000000000 and 9999999999. The counting method is the same as the standard totalizer's.

Forward/reverse flow difference totalizer:

The difference in flow volumes in the forward and reverse directions is calculated and counted.

Contact input function (optional)

External 0% lock input:

Enables 0% stop of the flow indication, analog output, digital output and pulse output via contact input.

External automatic zero adjustment input:

Adjusts the zeropoint by contact input.

External range changeover input:

Switches double range or forward/reverse range is achieved by contact input.

Built-in counter reset input

(optional for pulse output model):

Resets the integrated value of the built-in counter by contact input.

Contact output function (optional):

Alarm actuating contact output:

Outputs alarm-actuating contacts for self-diagnosis, no-load detection, and upper/lower flow limit value alarm.

Range identification output:

Outputs ID signal contacts for large and small ranges, forward and reverse direction ranges.

Preset status output (for the pulse output model):

Outputs a contact is output when the built-in counter reaches the preset value.

Self-diagnosis alarm output:

Outputs an alarm-actuating contact when the self-diagnosis function detects an error.

Empty-status detection:

Outputs an alarm-actuating contact when the fluid level in the detector goes below the electrode level.

Upper/lower flow limit value alarm output:

Outputs an alarm-actuating contact is output when the flow volume exceeds the set upper/lower limit values.

**Two-stage flow value alarm output:
(with two contact outputs)**

Outputs an alarm-actuating contact when the simultaneous flow value exceeds the set two upper limits (H and HH) or the two lower limits (L and LL).

Additional specifications (optional)

No-load detection function:

When the fluid level in the detector goes below the electrode level, the analog output, digital output and pulse output are fixed at 0%.

Pulse output:

Refer to "Output" in the standard specifications.

Certification of traceability:

From 3 sources: Measuring management system the configuration for your electromagnetic flowmeter, a repair certification, and test reports.

Tropicalization treatment (for transportation/storage):

Protects the electromagnetic flow meter in harsh environments during transportation and/or storage. The following treatments can be applied: corrosion protection, moisture prevention and mildew proofing.

Indication other than SI units:

Units to be exported other than SI units. Those units are as follows:

Volume unit:

B (barrel), kG (kilo-gallon), G (gallon),
mG (milli-gallon)

Mass unit: r b

Tag number on terminal box:

The designated tag numbers (maximum 16 characters) should be stamped on a plate, which is attached to the terminal box. One line can contain 8 characters, so if more characters must be written on two lines. Characters can be upper-case English letters, numbers and hyphens (-).

PT1/4 air purge hole:

One of the cable connection ports is a dedicated air purge hole with threads for a PT1/4 screw.

For additional specifications, please contact your Yamatake Corporation representative.

Performance (standard)

Measurable condition rate:

With detector of 2.5mm to 1100mm in diameter;
3 μ S/cm or more (consult your Yamatake Corporation engineer when conditions are 3 μ S/cm or less.)

Accuracy (in combination with a detector):

Refer to Table 1.

Table 1

<diameter 2.5~15mm>		Upper limit value of Vs=set velocity range
Vs (m/s)	Velocity during measurement \geq Vs \times 40%	Velocity during measurement \leq Vs \times 40%
1.0 \leq Vs \leq 10	\pm 0.5% of indicated value	\pm 0.2% of Vs
0.1 \leq Vs \leq 1.0	\pm (0.1/Vs+0.4%) of the indicated value	\pm 0.4(0.1/Vs+0.4)% of Vs

<diameter 25~600mm>		Upper limit value of Vs=set velocity range
Vs (m/s)	Velocity during measurement \geq Vs \times 20%	Velocity during measurement \leq Vs \times 20%
1.0 \leq Vs \leq 10	\pm 0.5% of indicated value	\pm 0.1% of Vs
0.1 \leq Vs \leq 1.0	\pm (0.1/Vs+0.4%) of the indicated value	\pm 0.2(0.1/Vs+0.4)% of Vs

<diameter 700~1100mm>		Upper limit value of Vs=set velocity range
Vs (m/s)	Velocity during measurement \geq Vs \times 50%	Velocity during measurement \leq Vs \times 50%
1.0 \leq Vs \leq 10	\pm 1.0% of indicated value	\pm 0.5% of Vs
0.1 \leq Vs \leq 1.0	\pm (0.2/Vs+0.8%) of the indicated value	\pm 0.5(0.2/Vs+0.8)% of Vs

MagneW 3000 FLEX (General Converter/Remote models)

Basic Model No.

MGG10C

		Selections	Optional selections	Options
Power supply	AC100V 50/60Hz	A		
	AC110V 50/60Hz	B		
	AC115/120V 50/60Hz	C		
	AC200V 50/60Hz	D		
	AC220V 50/60Hz	E		
	AC230/240V 50/60Hz	F		
	DC24V AC Noise filter 50Hz	G		
	DC24V AC Noise filter 60Hz	H		
Output signal/ Communication	Volume flow 4-20mA DC output /Without communication	A		
	Volume flow 4-20mA DC output /With communication	B		
	Volume flow DE output /With communication	C		
	Others			
Conduit connection/ Watertight gland	G1/2 internal thread/Without watertight gland			
	G1/2 internal thread/With brass(Ni-plated) watertight gland	1		
	G1/2 internal thread/With plastic watertight gland	2		
	1/2NPT internal thread/Without watertight gland	3		
	CM20 internal thread/Without watertight gland	4		
	Pg13.5 internal thread/Without watertight gland	5		
Installation/ Wiring direction	Remote model			
	Wall mounting/With standard bracket			
	2B pipe mounting/With standard bracket	G		
	Others			
			X Finish	Standard finish
			1	Corrosion-resistant finish
			2	Corrosion-proof finish
			X Display/Data setting device	None
			A	With display and data setting device
			X Contact inputs/outputs	None
			1	1 input and 1 output
			2	2 inputs
			3	2 outputs
			X Approval	None

Converter Terminal Correspondence Table

1-contact input and 1-contact output

Symbol	Description
A	Flow rate signal input
B	
C	
SA	
SB	
I.OUT	+ Current output
	-
P.OUT	+ Pulse output
	-
X	Excitation output
Y	
STATUS OUT	+ Contact output
	-
STATUS IN	+ Contact input
	-
POWER AC	L Power supply
	N
E	Not used
$\frac{1}{\text{---}}$	Class 3 grounding

2-contact input

Symbol	Description
A	Flow rate signal input
B	
C	
SA	
SB	
I.OUT	+ Current output
	-
P.OUT	+ Pulse output
	-
X	Excitation output
Y	
STATUS IN 2	+ Contact input 2
	-
STATUS IN 1	+ Contact input 1
	-
POWER AC	L Power supply
	N
E	Not used
$\frac{1}{\text{---}}$	Class 3 grounding

2-contact output

Symbol	Description
A	Flow rate signal input
B	
C	
SA	
SB	
I.OUT	+ Current output
	-
P.OUT	+ Pulse output
	-
X	Excitation output
Y	
STATUS OUT1	+ Contact output 1
	-
STATUS OUT2	+ Contact output 2
	-
POWER AC	L Power supply
	N
E	Not used
$\frac{1}{\text{---}}$	Class 3 grounding

Note) When the power supply is 24 V DC, "POWER AC" should read "POWER 24 V DC."

Dimension

(Unit:mm)

Wall mounting

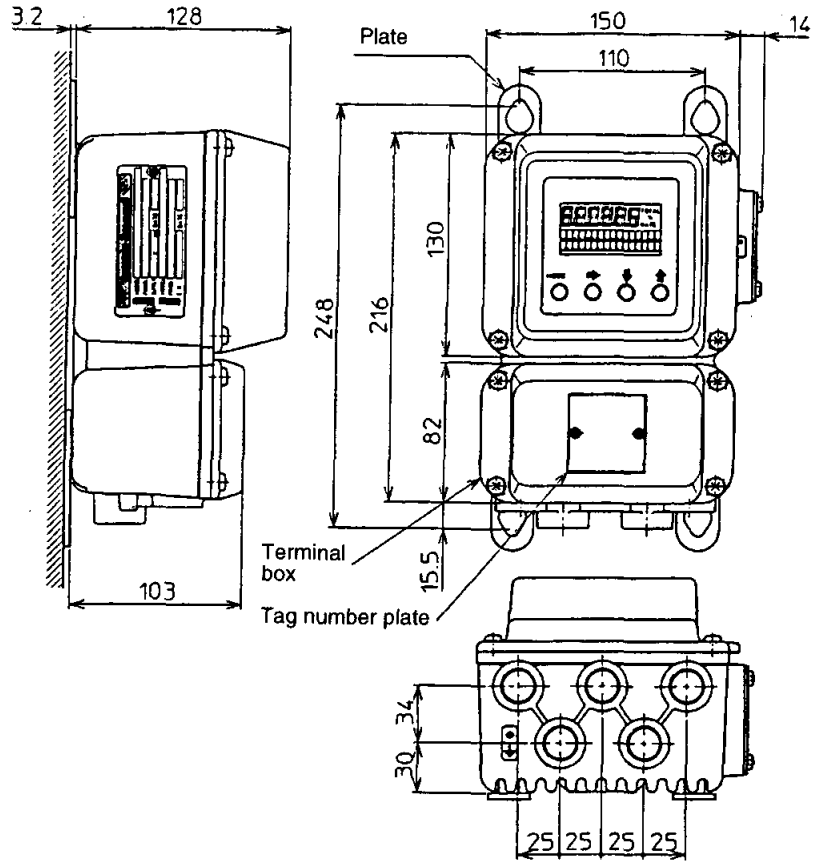

2-inch pipe mounted

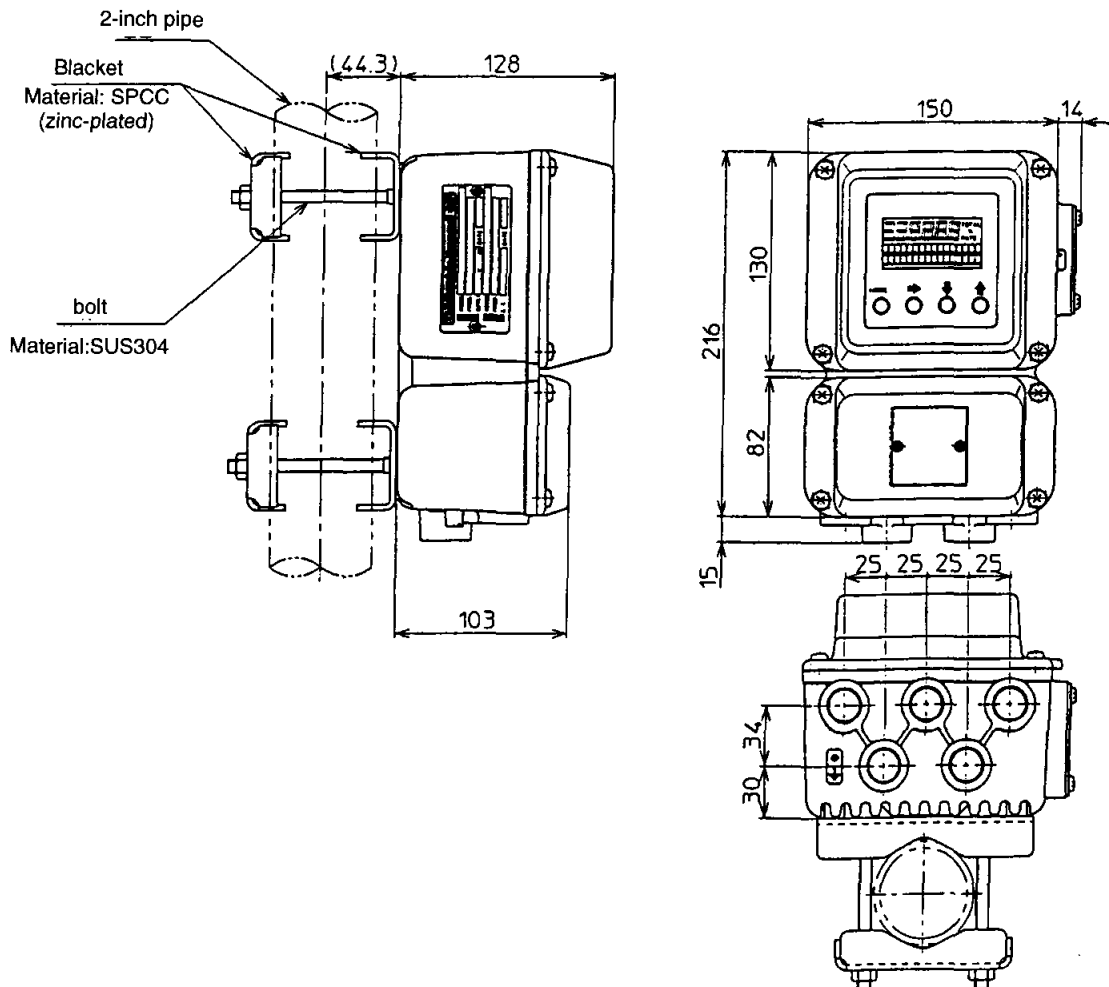

Integral Type

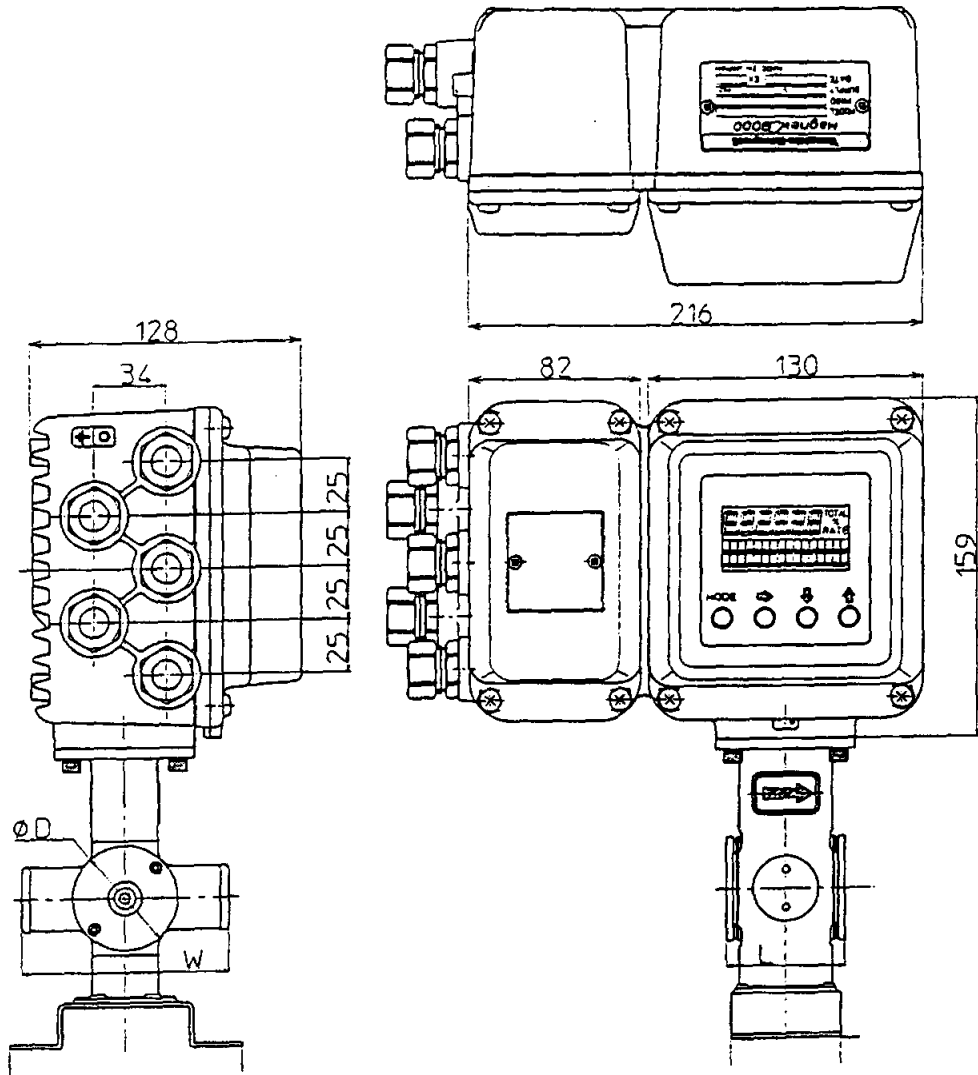

Note: The mass of an integral detector is 100g less than the mass of remote detectors.

Introduction

The MGA 12W/KIW type signal/excitation cables are dedicated detector-converter connection cables for the MagneW, MagneW 3000, and MagneW 3000 Flex flowmeters. They consist of a signal cable to convey the electromotive force generated in the detector and an excitation cable to convey excitation current.

With the MGA 12W type, terminals are all treated with shield drives. With the KIW type signal cable, however, terminal treatment differs according to the relations between the detector diameter, fluid conductivity, and cable length. In selecting terminal treatment, therefore, refer to the graphs shown in the figure "Relation Between Fluid Conductivity and Cable Length."

Standard Specifications

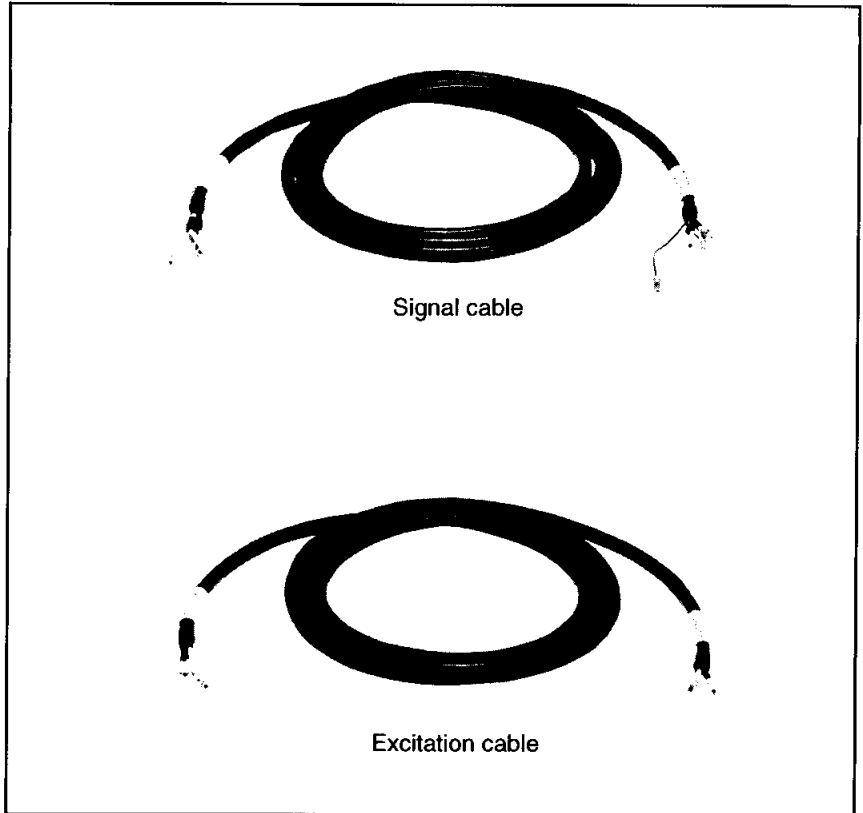

Signal cable : 2-core individual double-shielded cable
(Nominal cross section: 0.75 mm²; outside diameter: 11.4 mm)

Excitation cable : 2-core chloroprene cable
(Nominal cross section: 2 mm²; outside diameter: 11.4 mm)

Mass:

Signal cable : approx. 2 kg/10 m
Excitation cable : approx. 1.5 kg/10 m

Figure 1 Relation Between Fluid Conductivity and Cable Length (KIW Type)

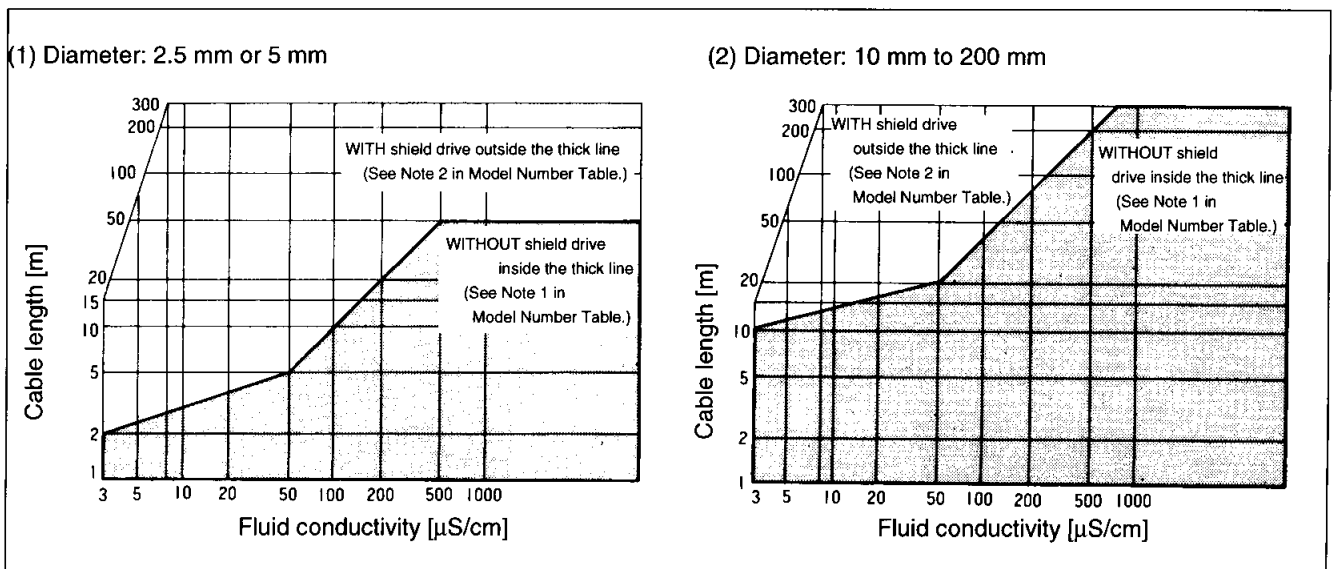

Note) With the MGA 12W type, all lengths inside the graph are applicable.

Model Numbers

Between Detector and Converter (MagneW 3000 and MagneW 3000 FLEX)

Basic model No.	Selections		Description	
	Cable length (L)	Terminal treatment		
		Detector side		Converter side
MGA12W-A			Signal cable	
MGW12W-B			Excitation cable	
MGA12W-C			One signal cable and one excitation cable	
	□□□		Three-digit display in m For model numbers, refer to Instrument Specifications.	
		A	MGG□□□D	
		X	No terminal treatment	
		A	MGG□□□C	
		X	No terminal treatment	

Between Detector and Zener Barrier (MagneW 3000 Using KID 15B Detector)

Basic model No.	Selections		Description	
	Cable length (L)	Terminal treatment		
		Detector side		Zener barrier side
KIW			Dedicated cable for MagneW electromagnetic flowmeters	
	XI		Signal cable	
	-□□□		Three-digit display in m	
		B	For KID 15B type (See Note 1.)	
		D	For KID 15B type (See Note 2.)	
		E	For zener barrier 8907	

Between Zener Barrier and Converter (MagneW 3000 Using KID 15B Detector)

Basic model No.	Selections		Description	
	Cable length (L)	Terminal treatment		
		Zener barrier side		Converter side
KIW			Dedicated cable for MagneW electromagnetic flowmeters	
	XI		Signal cable	
	-□□□		Three-digit display in m	
		E	For zener barrier 8907	
		C	For KIC/KIX type (See Note 1.)	
		D	For KIC/KIX type (See Note 2.)	

Note 1) To be selected when the relation between fluid conductivity and cable length is inside the thick line in figure 1 (WITHOUT shield drive)

Note 2) To be selected when the relation between fluid conductivity and cable length is outside the thick line in figure 1 (WITH shield drive)

Signal Cable

(Unit:mm)

Terminal treatment on detector side Terminal treatment on converter side

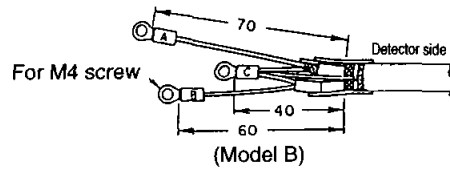
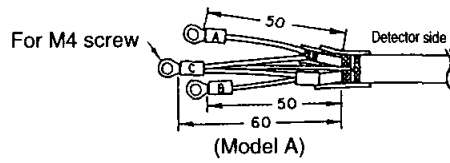
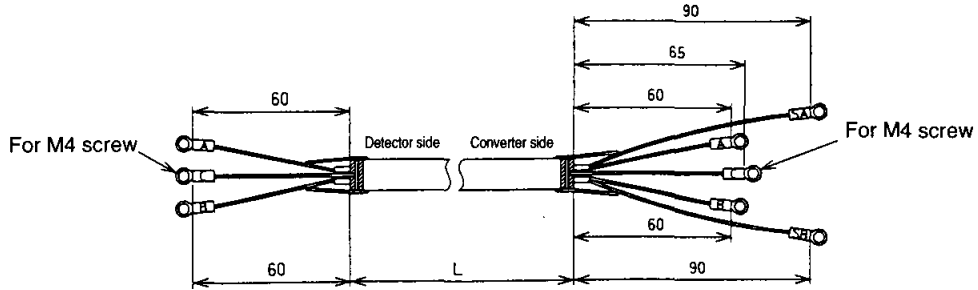

Terminal treatment on detector side Terminal treatment on zener barrier side

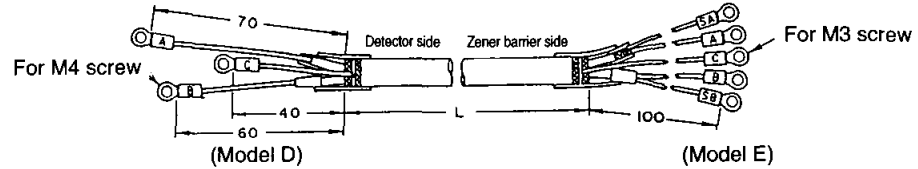
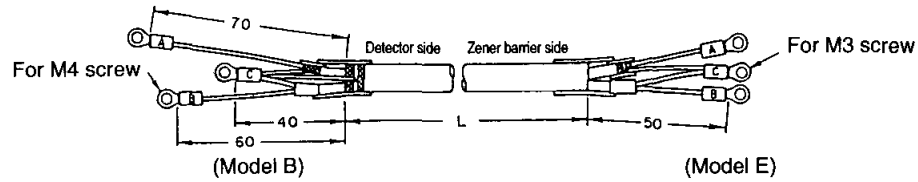

Terminal treatment on zener barrier side Terminal treatment on converter side

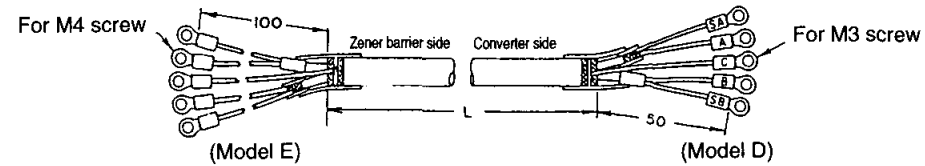
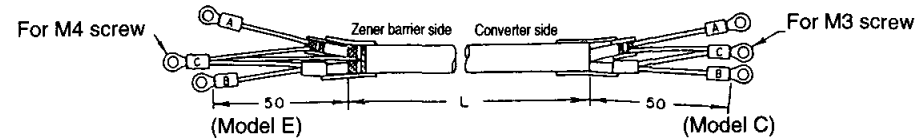

Signal Cable Construction

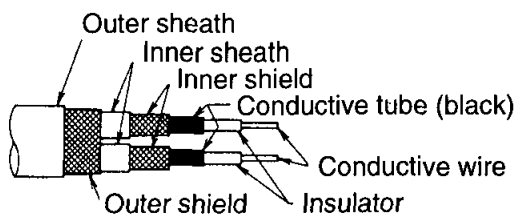

Note) Strip the conductive tubing (black) down to the ends of the inner shields on the conductor wires for terminals A and B.

Excitation Cables

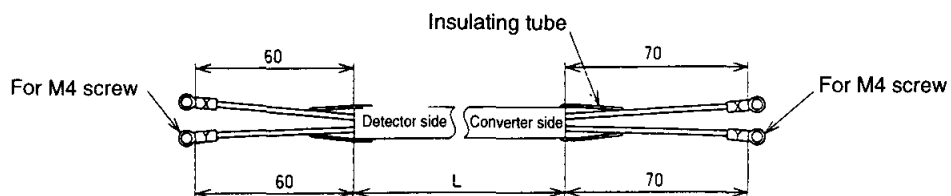

Terminal treatment on detector side

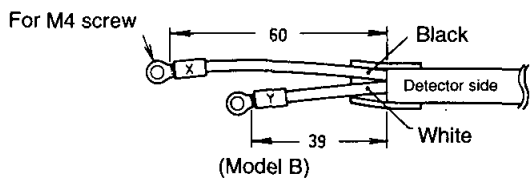
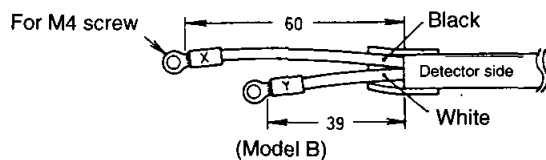
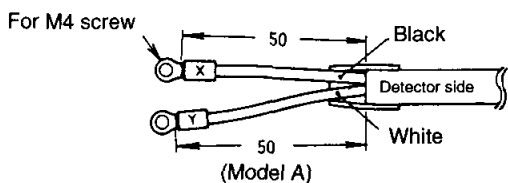
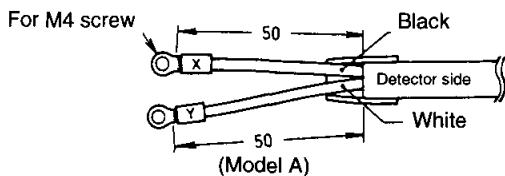

Excitation Cable Construction

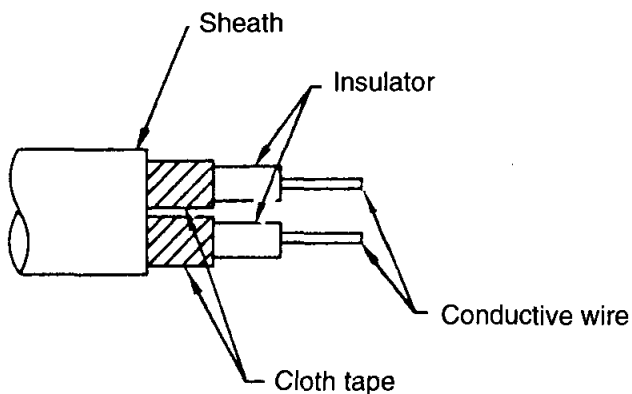

Document Number : CM2-MGG110-2001
Document Name : MagneW3000 FLEX Smart
Electromagnetic Flowmeter General Use
Converter Model MGG10C

Date : Feb., 1997
July., 1998 Rev.2

Issued / Edited by : Yamatake Corporation
