

# Analog Output and Digital Output

---

## Introduction

The configuration chosen depends on the purpose: systems with an analog signal output and systems with a digital signal output. Different equipment will be required depending on the output required.

---

## Analog output (4 - 20 mA DC output)

An analog output system outputs only the instantaneous flow rate as an analog value to the control equipment.

---

## Digital output (DE output)

A digital output system outputs the instantaneous flow rate, the database in the unit, and self-diagnosis to the control equipment.

---

## Switching output

The output for this unit can be selected. Refer to the "selective specifications" in the model number organization. Additionally, output can be changed on-site using the smart communicator (S-SFC).

---

## System Configuration for Digital Output (DE Output)

### System configuration

Figure 1-5 shows a system configuration in which the flow rate measured by the unit, the database in the unit, and self-diagnostics are output using the DE (Digital Enhancement) protocol (rules for digital signal communication).

In this system, the DE protocol-based digital signal transmitted from the unit is output to the control system after conversion to an analog signal at the smart protocol converter (SPC). Or, the digital signal is directly transmitted to the control system, if it is capable of receiving the DE protocol-based signal directly.

Figure 1-5 System configuration for digital output

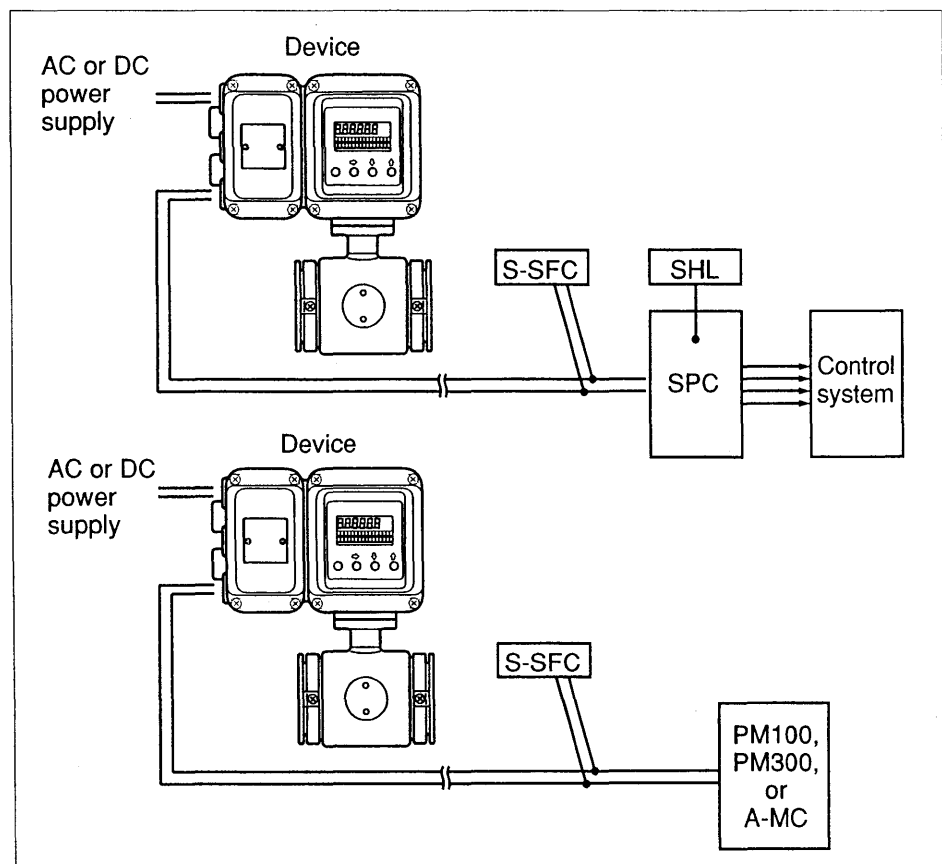

- Smart electromagnetic flowmeter (device): Measures the flow rate and outputs the instantaneous flow rate and unit self-diagnostics using a digital signal.
- Smart protocol converter (SPC): Converts the DE protocol-based digital signal into a 4 - 20 mA or 1 - 5 V DC analog signal for output.
- Smart handy loader (SHL): Used to change the SPC settings.
- Smart communicator (S-SFC): Used to communicate with the device to read data and change the device settings.
- PM100: Simultaneously executes such functions as process control on the UCN, regulatory control, sequencing, calculation, and process input/output.

# Electrical Wiring (5)

## Current output wiring

The current output wiring method depends on whether or not communication with the S-SFC is used.

An external power supply is required to communicate with the S-SFC.  
(Switch the main board pins after turning the power supply OFF.)

Figure 2-11 Wiring diagram for current output

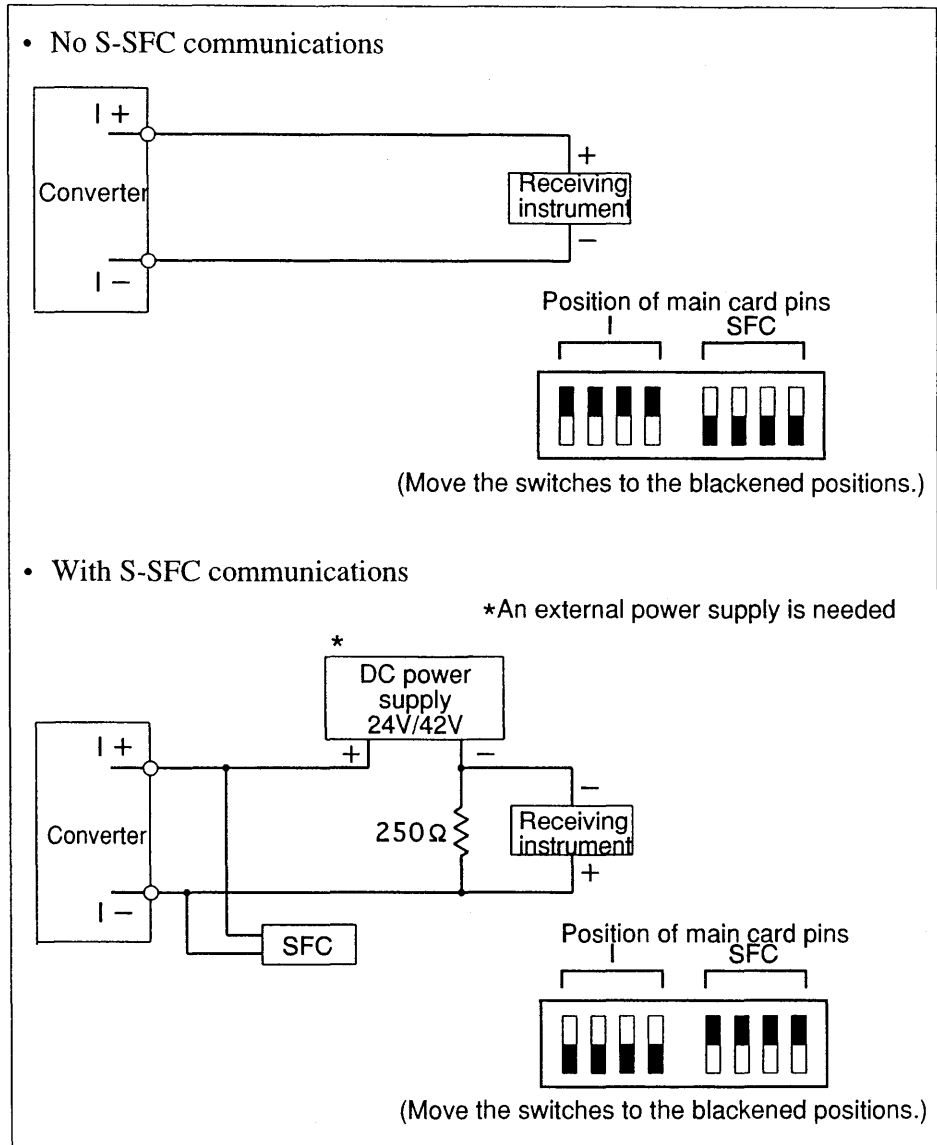

**Note:**

- Miswiring of polarity may cause damage to the equipment. Recheck the wiring position carefully.

## 2-4-6 Switching Between Digital and Analog Output - A<->DE

### Introduction

This function allows you to switch the SMT output configuration between analog and digital.

### Important

Before switching the output configuration, make sure to change the host control system to manual mode in order to prevent the switch in output configuration from affecting the host control system.

### Procedure

Follow the procedure given in Table 2-19 to switch the SMT output configuration.

Table 2-19 Switching the SMT Output Configuration

Step	Action	SFC Display
1	Verify that the SFC is in READY status. If not, press the CLR key to place the SFC into READY status.	MAG XXXXXXXXX READY...
2	Press the SHIFT key.	SHIFT-
3	Press the <- (A <->DE) key. <b>Result:</b> <ul style="list-style-type: none"> <li>The readout on the right appears if the output configuration is digital.</li> <li>The readout on the right appears if the output configuration is analog.</li> </ul>	MAG DE. XXXXXXXX CHNG TO ANALOG? (Digital configuration)  MAG XXXXXXXXX CHNG TO DIGITAL? (Analog configuration)
4	Press the ENTER key. <b>Branch:</b> <ul style="list-style-type: none"> <li>To cancel the switch, press the CLR key.</li> </ul> <b>Result:</b> <ul style="list-style-type: none"> <li>The readout for step 1 reappears on the display.</li> </ul>	MAG XXXXXXXXX ARE YOU SURE !?

*Continued on next page*

## 2-4-6 Switching between Digital and Analog Output - A<-->DE

Continued

### Procedure (continued)

Table 2-19 Switching the SMT Output Configuration (continued)

Step	Action	SFC Display				
5	Press the ENTER key.	<table border="1"><tr><td data-bbox="1166 506 1417 573">MAG XXXXXXXXX WORKING...</td></tr><tr><td data-bbox="1166 595 1417 663">MAG XXXXXXXXX ANALOG XMTR</td></tr><tr><td data-bbox="1166 685 1417 719">or</td></tr><tr><td data-bbox="1166 741 1417 808">MAG XXXXXXXXX DE XMTR</td></tr></table>	MAG XXXXXXXXX WORKING...	MAG XXXXXXXXX ANALOG XMTR	or	MAG XXXXXXXXX DE XMTR
MAG XXXXXXXXX WORKING...						
MAG XXXXXXXXX ANALOG XMTR						
or						
MAG XXXXXXXXX DE XMTR						