

MagneW Two-wire PLUS⁺

Smart Two-wire Electromagnetic Flowmeter

Model MTG18A (Integral type)

Model MTG14C/MTG18B (Remote type)

OVERVIEW

The MagneW Two-wire PLUS⁺ is a high performance electromagnetic flowmeter based on field proven Yamatake two-wire loop powered technology. The MagneW Two-wire PLUS offers the stable and accurate measurement of a traditional magflow meter with low power consumption. The result is a lower overall cost of ownership.

FEATURES

Two-wire operation

MagneW Two-wire PLUS⁺ improves its noise immunity performance by 700% maximum and 250% in average. For the spike noise, MagneW Two-wire PLUS⁺ improves its noise immunity performance in 250% in average.

High accuracy and stable output

MagneW Two-wire PLUS⁺ provides high accuracy ($\pm 0.5\%$ of rate) and its output is as stable as current four wired magnetic flowmeters.

Minimum measurable fluid conductivity

The MagneW Two-wire PLUS⁺ offers a minimum process fluid conductivity of $10\mu\text{S}/\text{cm}$ which is the best among two-wire magflow meters thereby maximizing applicability.

Wider range in size

MagneW Two-wire PLUS⁺ offers wider range in detector size.

Detector size: 2.5 to 200 mm.

Wafer and flange style, integral and remote style available

The MagneW Two-wire PLUS⁺ is available integral or remote, flanged or wafer, making the selection of the right meter for the application simple.

Electrode status diagnostic function

The MagneW Two-wire PLUS⁺ offers the



Integral type

Remote type

diagnostic function for the electrode condition. It diagnoses the Empty pipe condition or scale on electrode condition.

APPLICATIONS

- Corrosive liquid measurement
- Chemical solution measurement
- Drainage/waste disposal fluid measurement
- Drinking water and waste water service
- Industrial/agricultural water measurement
- Seawater measurement

FUNCTIONAL SPECIFICATIONS

Enclosure rating

NEMA TYPE 4X, IEC IP67

Hazardous Areas certifications

Integral type

FM approval

<for Division 1>

Class I, Division 1, Groups A, B, C & D, T4;
 Class II, Division 1, Groups E, F & G, T4;
 Class III, T4, $-20^{\circ}\text{C} \leq T_{amb} \leq +60^{\circ}\text{C}$

<for Division 2>

Nonincendive for
 Class I, Division 2, Groups A, B, C & D, T4;
 Class II, Division 2, Groups F & G, T4;
 Class III, T4; Class I, Zone 2, Group IIC, T4,
 $-20^{\circ}\text{C} \leq T_{amb} \leq +60^{\circ}\text{C}$

CSA certification

<for Division 1>

Class I, Division 1, Groups A, B, C & D, T4;
 Class II, Division 1, Groups E, F & G, T4;
 Class III, T4, $-20^{\circ}\text{C} \leq T_{amb} \leq +60^{\circ}\text{C}$

<for Division 2>

Class I, Division 2, Groups A, B, C, & D, T4;
 Class II, Division 2, Groups E, F & G, T4;
 Class III, T4, $-20^{\circ}\text{C} \leq T_{amb} \leq +60^{\circ}\text{C}$

ATEX(KEMA) Certification

<for Type n>

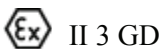

Ex nA II T6 T135°C at Tprocess: $-40...+85^{\circ}\text{C}$
 Ex nA II T5 T135°C at Tprocess: $-40...+100^{\circ}\text{C}$
 Ex nA II T4 T135°C at Tprocess: $-40...+130^{\circ}\text{C}$
 $-40^{\circ}\text{C} \leq T_{amb} \leq +60^{\circ}\text{C}$
 KEMA 07ATEX0066
 IP66/67

NEPSI Certification

<for Type n>

Ex nA II T6 DIP A21 TA 135°C at Tprocess=85°C
 Ex nA II T5 DIP A21 TA 135°C at Tprocess=100°C
 Ex nA II T4 DIP A21 TA 135°C at Tprocess=130°C
 $-40^{\circ}\text{C} \leq T_{amb} \leq +60^{\circ}\text{C}$

Remote type

FM approval

<for Division 2>

Nonincendive for
 Class I, Division 2, Groups A, B, C & D, T4;
 Class II, Division 2, Groups F & G, T4;
 Class III, T4; Class I, Zone 2, Group IIC, T4,
 $-20^{\circ}\text{C} \leq T_{amb} \leq +60^{\circ}\text{C}$

CSA certification

<for Division 2>

Class I, Division 2, Groups A, B, C & D, T4;
 Class II, Division 2, Groups E, F & G, T4;
 Class III, T4, $-20^{\circ}\text{C} \leq T_{amb} \leq +60^{\circ}\text{C}$

EU Pressure Equipment Directive (97/23/EC)

Model MTG18A and MTG18B are in accordance with SEP category (Article 3, paragraph 3).

for dangerous liquids

DN	Maximum Pressure
Less than 65mm	30bar
80mm	25bar
100mm	20bar
150mm	13bar
200mm	10bar

for non dangerous liquids

The maximum process pressure is 30bar for all sizes.

Output signal

Analog output

4 to 20 mA DC

Digital output

DE

Analog or Digital output is selectable.

Pulse output

Open collector output (30V DC, 100 mA max.)

Pulse frequency: 0.0001 to 200 Hz

Pulse width: 1 ms to 1 s

LOW value: 2.7V (10mA) (Refer to the blow drawing.)

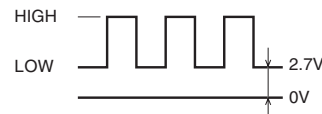

Contact output

Open collector output (30V DC, 100 mA max.)

Pulse or contact output is selectable

Communication protocol

SFC communication and HART communication

HART® communication

- Multidrop mode: current fixed at 12mA
 Optional Burst mode is not available.

Load resistance characteristic of communication

External power supply 21.05 to 42V DC for communication.

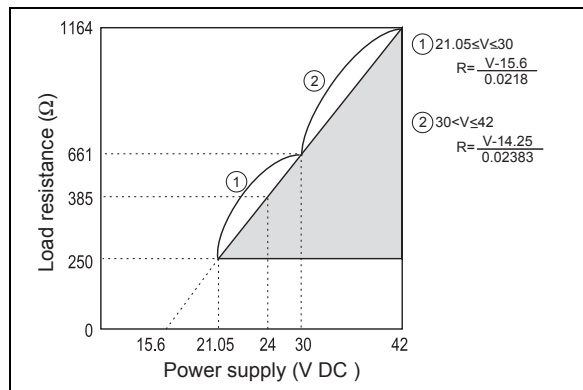

Note) The load resistance of 250 Ω or more is necessary for communications of SFC and the HART communicator.

Flow unit

Volume flow: m³, L, cm³, G (gallon), mG, kG,
B (barrel), IG (imperial gallon), mlG,
kIG

Mass flow: t, kg, g, lb

Time: d, h, min., s

Display

Display: LCD

Main display: 7-segment, 8 digits

Sub display: 16 digits, 2 lines

Display contents:

Simultaneously displays % flow rate, Actual flow rate (eng. unit) and Totalized value.

Data setting

Operation by four key switches

Damping

Adjustable between 0.5 and 199.9 seconds.

Low flow cutoff

Adjustable between 0 and 10% of setting range.

Below selected value, output is driven to the zero flow rate signal level.

Dropout

Adjustable between 0 and 10% of setting range.

Below selected value, pulse output is cut.

Electrode status diagnostic

Detect empty pipe condition or scale on electrode condition by monitoring flow rate signal. Once the flow rate signal fluctuates over a certain threshold, the device judges that the detector is empty or scale appears on the electrode.

The Electrode status diagnostic function makes the analog output and pulse output to the values as selected in the below "Electrode status output mode" table.

The display alternately shows the output values selected and "EMPTY OR SCALE ON ELECTRODE".

There are five threshold levels to meet an environment where the device is installed. Set an appropriate threshold level from below.

SENSITIVITY HIGH

SENSITIVITY MID

SENSITIVITY LOW

SENSITIVITY LL

SENSITIVITY LLL

Default setting: OFF

Operating condition:

The following conditions must be met when using the electrode status diagnostic function.

- Diameter: 10mm or larger
- Electric conductivity of fluid: 30 μS/cm or greater
- Grounding: Grounding resistance must be less than 100Ω
- The noise level must be over the set threshold when the pipe is empty.
- The noise level must be under the set threshold when the process fluid flows in the detector.

“Electrode status output mode” table”

Output/Display	Parameter selection in the “Electrode status output mode”		
	OFF	ZERO	HOLD
Analog 4 – 20mA output	Output values as the meter measures.	Analog output is fixed to 0% (4mA).	Analog output is held at its last good value.
Pulse output	Output values as the meter measures.	Pulse output is fixed to 0 (does not generate pulses).	Pulse output is held at its present state.
Display	Display the value as it measures.	Flashes the message 0% and “Empty or scale on electrode” alternately (when % flow rate is specified for the main display). Flashes the message 0.000 RATE and “Empty or scale on electrode” alternately (when actual flow rate is specified for the main display). Flashes the message XXXXXXXX (totalized value at setup) and “Empty or scale on electrode” alternately (when totalized value is specified for the main display).	Flashes the values at its last good values and a message of “Empty or scale on electrode” alternately.

Lightning protection

12 kV, 1000A

Equipped with the lightning arrester in the power source and external output terminals.

Power failure

An EEPROM retains data record of totalized value when pulse output is used (retention period approximately 10 years).

Power supply

15.6 to 42V DC (without communication)

21.05 to 42V DC (with communication)

Current capacity: 24mA min.

In case of current capacity is 22mA, the voltage must be 15.6V minimum.

Size

Wafer style

25, 40, 50, 65, 80, 100 mm (1, 1½, 2, 2½, 3, 4 inches)

Flange style

2.5, 5 mm (0.1, 0.2 inch) (Model MTG18A only)

10, 15, 25, 40, 50, 65, 80, 100, 150, 200 mm (3/8, 1/2, 1, 1½, 2, 2½, 3, 4, 6, 8 inches)

Flange rating

ANSI150, ANSI300, DIN PN10, DIN PN16, DIN PN25, JIS10K, JIS20K, JIS30K

Reference flange standard

JIS; JIS B2210 (1984)

ANSI; ANSI B16.5 (1988)

Ambient temperature limits

-20 to 60°C (-4 to 140°F)

Ambient humidity limits

10 to 90% RH

Vibration effect

Integral style: 4.9m/s²(0.5G) max.

Remote style converter: 19.6m/s²(2G) max.

Remote style detector: 19.6m/s²(2G) max.

Temperature range and pressure range of process fluid

Refer to the following.

Size: 2.5 to 10 mm (0.1 to 3/8 inch)

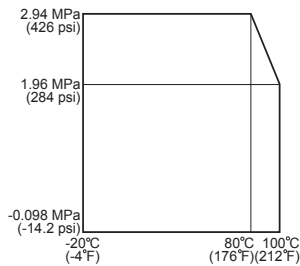

Size: 15 to 200 mm (1/2 to 8 inch)

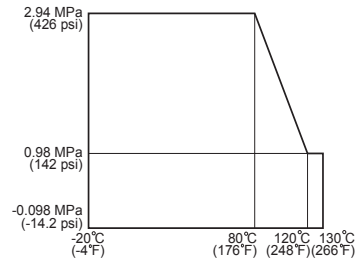

Measurable electrical conductivity

10 µS/cm or greater

50 µS/cm or greater (10 mm (3/8 inch), 15 mm (1/2 inch) for remote type)

Measurement flow range

Size		Maximum flow velocity range is 0 to 0.3 m/s (0 to 0.98 ft/s)		Maximum flow velocity range is 0 to 10 m/s (0 to 32.8 ft/s)		Conversion factor K
		Minimum range		Maximum range		
mm	inches	m ³ /h	GPM	m ³ /h	GPM	
2.5	0.1	0 to 0.00531	0 to 0.02335	0 to 0.1767	0 to 0.778	56.59
5	0.2	0 to 0.02121	0 to 0.09337	0 to 0.7068	0 to 3.112	14.15
10	3/8	0 to 0.08483	0 to 0.3735	0 to 2.827	0 to 12.44	3.537
15	1/2	0 to 0.1909	0 to 0.8404	0 to 6.361	0 to 28.00	1.572
25	1	0 to 0.5302	0 to 2.335	0 to 17.67	0 to 77.80	0.5659
40	1½	0 to 1.358	0 to 5.976	0 to 45.23	0 to 199.1	0.2210
50	2	0 to 2.121	0 to 9.337	0 to 70.68	0 to 311.2	0.1415
65	2½	0 to 3.584	0 to 15.78	0 to 119.4	0 to 525.9	0.08371
80	3	0 to 5.429	0 to 23.91	0 to 180.9	0 to 796.7	0.05526
100	4	0 to 8.483	0 to 37.35	0 to 282.7	0 to 1244	0.03537
150	6	0 to 19.09	0 to 84.04	0 to 636.1	0 to 2800	0.01572
200	8	0 to 33.93	0 to 149.4	0 to 1130	0 to 4979	0.008842

Velocity V (m/s) = K × Q

K = Conversion factor = 1/3600 × 4/(πD²) × 1000², D = Size (mm), Q = Flow rate (m³/h)

VPERFORMANCE SPECIFICATIONS

Analog output accuracy

Size: 2.5, 5 mm (0.1, 0.2 inch)

V_s = velocity of setting range (m/s)

V_s (m/s)	Velocity during measurement $\geq V_s \times 50\%$	Velocity during measurement $\leq V_s \times 50\%$
$1.0 \leq V_s \leq 10$	$\pm 0.5\%$ of rate	$\pm 0.5\%$ of V_s
$0.3 \leq V_s \leq 1.0$	$\pm \frac{0.5}{V_s} \%$ of rate	$\pm 0.5 + \left(\frac{0.5}{V_s}\right) \%$ of V_s

Size: 10, 15 mm (3/8, 1/2 inch)

V_s = velocity of setting range (m/s)

V_s (m/s)	Velocity during measurement $\geq V_s \times 40\%$	Velocity during measurement $\leq V_s \times 40\%$
$1.0 \leq V_s \leq 10$	$\pm 0.5\%$ of rate	$\pm 0.5\%$ of V_s
$0.3 \leq V_s \leq 1.0$	$\pm \frac{0.5}{V_s} \%$ of rate	$\pm 0.4 + \left(\frac{0.5}{V_s}\right) \%$ of V_s

Size: 25 to 200 mm (1 to 8 inches)

V_s = velocity of setting range (m/s)

V_s (m/s)	Velocity during measurement $\geq V_s \times 30\%$	Velocity during measurement $\leq V_s \times 30\%$
$1.0 \leq V_s \leq 10$	$\pm 0.5\%$ of rate	$\pm 0.5\%$ of V_s
$0.3 \leq V_s \leq 1.0$	$\pm \frac{0.5}{V_s} \%$ of rate	$\pm 0.3 + \left(\frac{0.5}{V_s}\right) \%$ of V_s

Accuracy is guaranteed by the totalized flow volume under the condition of continuous flow measurement for 30 seconds or longer.

PHYSICAL SPECIFICATIONS

Converter case finishing

Standard

Baked acrylic paint

Corrosion-proof

Baked epoxy paint

Converter case material

Aluminum alloy

Display cover material

Tempered glass

Terminal box finishing (Model MTG18B only)

Standard: Baked acrylic paint

Corrosion-proof: Baked epoxy paint

Terminal box material (Model MTG18B only)

Aluminum alloy

Detector main body materials

Case material

Size 2.5 to 15 mm (0.1 to 1/2 inch):

SCS13 stainless steel

Size 25 to 200 mm (1 to 8 inches):

SUS304 stainless steel

Measuring pipe material

SUS304 stainless steel

Flange

SUS304 stainless steel

(size 2.5 to 65 mm (0.1 to 2½ inches))

Carbon steel + corrosion-preventive painting
(size 80 to 200 mm (3 to 8 inches))

Process wetted materials

Lining: PFA

Electrodes

SUS316L, ASTM B574 (Hastelloy C-276 equivalent), Titanium, Tantalum, Nickel, Zirconium, Platinum-Iridium

Grounding rings

SUS316, ASTM B575 (Hastelloy C-276 equivalent), Titanium, Tantalum, Zirconium, Platinum

INSTALLATION

Electrical connection

1/2NPT internal thread (must be selected for FM approval)

CM20 internal thread

G1/2 internal thread

Remote converter mounting

Wall mounting, 2-inch pipe mounting

Grounding

The grounding is essential for flow measurement.

The most effective grounding method is direct connection to earth ground with minimal impedance.

For approval selection code "1", to maintain Intrinsic safety of system connect conductor to earth ground so that it has less than 1 Ohm to earth ground. See ANSI/ISA RP12.06.01 Installation of Intrinsically Safe Systems for Hazardous (Classified) Locations for guidance on installation of intrinsically safe apparatus and systems.

Pipe connection

Wafer style (Size: 25 to 100 mm (1 to 4 inches))

Flange style (Size: 2.5 to 200 mm (0.1 to 8 inches))

Length of straight pipe

Required straight pipe length clearance on the upstream side and the downstream side, while installing the detector.

Upstream side

A minimum 5D straight pipe length is required.

A minimum 10D straight pipe length is required if a diffuser/valve/pump is installed upstream side.

Downstream side

2D straight pipe length is recommended.

(Where D is the nominal bore diameter of the detector)

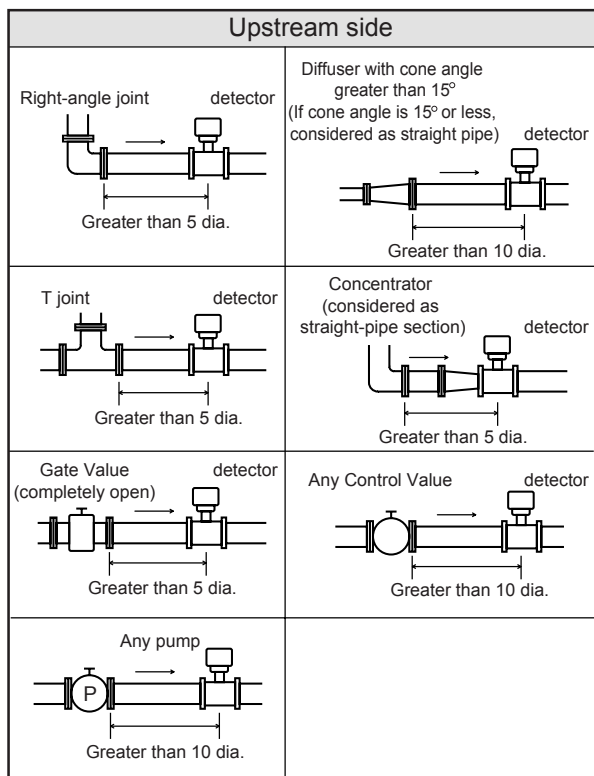

Figure 1

Cable between converter and detector
(Remote type)

Length

70 m (233 ft) or shorter
(25 mm (1 inch) to 200 mm (8 inches))
30 m (98 ft) or shorter
(10 mm (3/8 inch), 15 mm (1/2 inch))

Outside diameter

11.4 mm (0.45 inch)

Maximum cable length of SMC11 cable

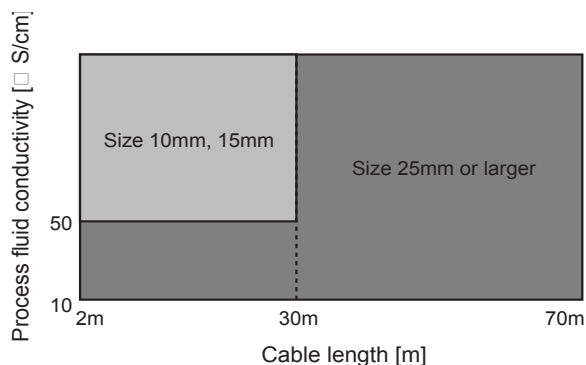

Figure 2 Maximum cable length of SMC11 cable

Notice for installation

To fully enjoy the performance of the device, please choose an appropriate location according to the following.

Notice after installation

WARNING

When removing the device from the piping, make sure that there is no line pressure or process fluid inside of the device. Removing the device before depressurizing may result in serious injury.

CAUTION

Do not use the device as a foothold. It may cause injury or damage of the device.

Notice for environment

- Install the flowmeter in a location with an ambient temperature of -25°C to 60°C (-13°F to 140°F) and an ambient humidity of 5 to 100%RH to prevent equipment malfunction or output errors.
- Do not install the flowmeter in a location subject to severe vibration or in a highly corrosive atmosphere. The converter and detector can be damaged. * When install some electromagnetic flowmeters in closer location, keep minimum 500mm (20 inch) space from each flowmeter. Closer electromagnetic flowmeter installation may cause magnetic interference each other and results in output errors.
- Do not install the flowmeter in a location subject to severe vibration or in a highly corrosive atmosphere. The converter and detector can be damaged.
- When install some electromagnetic flowmeters in closer location, keep minimum 500mm (20 inch) space from each flowmeter. Closer electromagnetic flowmeter installation may cause magnetic interference each other and results in output errors.

Notice for application

- Electrolytic bath application, process fluid with higher voltage/current
Process fluid of the electrolytic bath application is mostly with high voltage/current. It is not a suitable application for the two wire loop powered magnetic flowmeter.

Example: Sodium hypochlorite with 200V and 30kA

Four wire magnetic flowmeter is recommended.

- Application which pipe frequently becomes empty
Both two wire magnetic flowmeter and four wire magnetic flowmeter have empty pipe detection function. The two wire magnetic flowmeter detects empty by monitoring signal fluctuation caused by empty pipe condition. Therefore the empty pipe detection function of the two wire magnetic flowmeter sometimes does not work properly if noise level is too low or too high. The four wire magnetic flowmeter detects empty by monitoring impedance between electrodes and grounding. So the four wire magnetic flowmeter directly monitors the empty pipe condition. If the application requires empty detection quickly and perfectly, the four wire magnetic flowmeter is recommended.
- Plastic piping or piping with liner
If the customer piping is plastic or lined with insulation material, process fluid may not be properly grounded. In such case, it is recommended to connect earth wire between upstream side grounding ring and downstream side grounding ring for better grounding.
- Slurry application
Process fluid with slurry exceeds 3% is not suitable for the two wire magnetic flowmeter. The four wire magnetic flowmeter is recommended for the fluid with slurry concentration more than 3%.
If hard particles hit the electrode, output of the two wire magnetic flowmeter may fluctuate even though the slurry concentration is less than 3%. In this case, the four wire magnetic flowmeter is recommended.
- Electrochemically homogeneous fluid
Install the device where the process fluid is electrochemically homogeneous. If two kind of process fluids are mixed at the upstream side, the process fluid must be uniformly mixed.
- The application which the electric conductivity changes or non-homogeneous fluid
Do not use the device for the following fluid conditions even if the electric conductivity, temperature, and pressure are within the device specifications.

tions. Those fluid may cause of inaccurate flow measurement.

- Fluids that have sufficient conductivity at high temperature but do not meet the conductivity requirement at room temperature (about 20°C (68°F)). (e.g. fatty acids and soap)
- Some fluids contain surfactant (e.g. rinse, shampoo and CWM (coal water mixture))
- Insulating adhesive materials (e.g. kaolinite, kaolin, calcium stearate)
- The analog output may fluctuate due to flow noise, which is generated by the process fluid flow. In such a case, connect the upstream grounding ring to the downstream grounding ring by a wire. The output fluctuation may be reduced.

Caution On PLC Connection

A circuit in some PLC may affect the flow measurement and the analog output may fluctuate. In this case, make sure that the both PLC and the MagneW Two-wire PLUS+ flowmeter are properly grounded. Proper grounding solves the fluctuation problem.

Notice for power supply

- Use the following power supply. If the power supply does not meet the following specifications, this device may not work.
 - Current capacity: 24mA min.

CAUTION

In accordance with the safety standards of flameproof regulation, please comply with the following instructions.:

- (1) The voltage of general equipment such as the power supply and the receiver should not exceed 250VAC, 50/60Hz, 250VDC at any time at normal or abnormal operation.
- (2) The ambient temperature around the device is 50°C (122°F) maximum.
- (3) The process fluid temperature is 125°C (257°F) max. for the size of 15mm (1/2 inch) or larger.
- (4) The process fluid temperature is 100°C (212°F) max. for the size of 10mm (3/8 inch) or smaller.
- (5) Use the specified flameproof cable glands.
- (6) Wait for seven minutes after switching OFF the power supply, before opening the front cover or the terminal cover.

A specified explosion-proof performance is available only when this device is used under the conditions described above.

MODEL SELECTION

MagneW Two-wire PLUS⁺

Model MTG18A - I II III IV V VI VII VIII IX X XI - XII XIII - Options (some options can be selected per each model)

Basic model no.

Selections

Optional selections Options

MTG18A												
I	Line size	2.5 mm (0.1 inch) (flange type only)	002	*1								
		5 mm (0.2 inch) (flange type only)	005	*1								
		10 mm (3/8 inch) (flange type only)	010	*1								
		15 mm (0.5 inch) (flange type only)	015	*1								
		25 mm (1 inch)	025									
		40 mm (1½ inches)	040									
		50 mm (2 inches)	050									
		65 mm (2½ inches)	065									
		80 mm (3 inches)	080									
		100 mm (4 inches)	100									
		150 mm (6 inches) (flange type only)	150									
		200 mm (8 inches) (flange type only)	200									
II	Lining	PFA		P								
III	Pipe connection	Wafer JIS10K		11								
		Wafer JIS16/20K		12								
		Wafer JIS30K		13								
		Wafer ANSI 150		21								
		Wafer ANSI 300		22								
		Wafer DIN PN10		41								
		Wafer DIN PN16		42								
		Wafer DIN PN25		43								
		Flange JIS10K		J1								
		Flange JIS20K		J2								
		Flange JIS30K		J3								
		Flange JIS10K for 10 mm size flange		*2	J4							
		Flange JIS20K for 10 mm size flange		*2	J5							
		Flange ANSI 150			A1							
		Flange ANSI 300			A2							
		Flange DIN PN10			D1							
Flange DIN PN16			D2									
Flange DIN PN25			D3									
IV	Electrode	SUS316L		L								
		ASTM B574 (Hastelloy C-276 equivalent)		C								
		Titanium		K								
		Zirconium		H								
		Tantalum		T								
		Nickel		N								
		Platinum-iridium		P								
V	Grounding ring	SUS316		S								
		ASTM B575 (Hastelloy C-276 equivalent)		C								
		Titanium		K								
		Zirconium		H								
		Tantalum		T								
		Platinum		P								
		Nickel		N								
VI	Wiring connection	G1/2 internal thread		A								
		G1/2 internal thread with plastic water tight gland		B								
		G1/2 internal thread with brass Ni-plated watertight gland		C								
		1/2NPT internal thread (must be selected for FM approval)*4		D								
		CM20 internal thread		E								
		G1/2 internal thread with two plastic watertight glands		J								
		G1/2 internal thread with two brass Ni-plated watertight gland		K								
VII	Face-to-face dimension	Standard		A								
		Replacement for SMT3000 (for wafer type 40 to 100 mm)		S								
VIII	Installation / Display direction	Horizontal piping / Right side viewed from upstream		A								
		Horizontal piping / Left side viewed from upstream		B								
		Horizontal piping / Downstream side		C								
		Horizontal piping / Upstream side		D								
		Vertical piping / Right side of piping / Flow direction: Upward		E								
		Vertical piping mounting / Left side of piping / Flow direction: Upward		F								
IX	Calibration	Standard		J								
X	Output / communication	Volume flow 4-20mA DC output/with SFC communication		E								
		Volume flow DE output/with communication		D								
		Volume flow 4-20mA DC output with HART communication		T								
XI	Approval/ Certification	None		X								
		FM approval, Class I, II, III, Division 1, Groups A, B, C, D, E, F & G, T4		*5	1							
		CSA certification, Class I, II, III, Division 1, Groups A, B, C, D, E, F & G, T4		*5	2							
		FM approval, NI for Class I, II, III, Division 2, Groups A, B, C, D, F & G, T4										
		CSA certification, Class I, II, III, Division2, Groups A, B, C, D, E, F & G, T4										
		ATEX Type nA certification			4							
NPSI Type nA certification Ex nAII T4 to T6			6									

X	None			
B	Traccability certificate		Options	
C	Material certificate (electrode/grounding ring)			
G	Gasket for plastic piping			
J	Tropical treatment			
K	with tagging on the converter housing *3			
L	with tag number plate wired to the flowmeter			
X	Finish / paint	Standard paint		XII
2		Corrosion-proof paint		
X	Bolt and nut	None	XIII	
2		SUS304 (only for wafer type)		

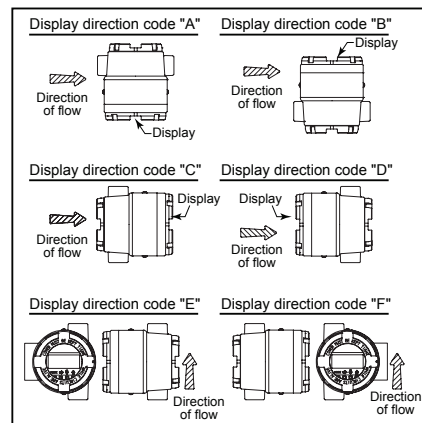

Note) *1: Flange of size 2.5 to 15 mm detector is 15 mm flange.
 *2: Available for size 2.5 to 10 mm detector.
 *3: Must be selected if tagging is required.
 *4: Must select "Approval 1 or 2".
 *5: Must select "Wiring connection D".

MagneW Two-wire PLUS⁺ Wafer/Flange remote type converter

Model MTG14C - I II III IV - Options (some options can be selected per each model)

Basic model no.

Basic model no.		Selections				Options
MTG14C						-
I	Analog output / communication	Volume flow 4-20 mA DC output / with SFC communication	E			
		Volume flow DE output / with communication	D			
		Volume flow 4-20 mA DC output / with HART communication	T			
II	Wiring connection	G1/2 internal thread	A			
		G1/2 internal thread with a plastic water-tight gland	B			
		G1/2 internal thread with a brass Ni-plated water-tight gland	C			
		1/2NPT internal thread	D			
		CM20 internal thread	E			
III	Converter mounting	Wall mounting with standard bracket	G			
		2-inch pipe mounting with standard bracket	H			
IV	Approval	None			X	
		FM approval, Class I, II, III, Division 2, Groups A, B, C, D, F & G, T4 CSA certification, Class I, II, III, Division 2, Groups A, B, C, D, E, F & G, T4	*2	2		
V	Option	None				X
		Traceability certificate				B
		With the Tag number plate on the converter housing			*1	K
		Corrosion-proof paint				2

Note) *1: Must be selected if tagging is required.

*2: Must select "Wiring connection D".

MagneW Two-wire PLUS⁺ Wafer/Flange remote type cable

Model SMC11 - I II III

Basic model no.

Basic model no.		Selections		
SMC11				
I	Cable	2 m (6 feet 8 inches)	02	
		3 m (10 feet)	03	
		4 m (13 feet 4 inches)	04	
		5 m (16 feet 8 inches)	05	
		10 m (33 feet 4 inches)	10	
		15 m (50 feet)	15	
		20 m (66 feet 8 inches)	20	
		30 m (100 feet)	30	
		40 m (133 feet 4 inches)	40	
		50 m (166 feet 8 inches)	50	
		60 m (200 feet)	60	
		70 m (233 feet 4 inches)	70	
		II	Terminals for detector	With terminals
III	Terminals for converter	With terminals		A

DIMENSIONS

All dimensions are in millimeters, dimensions in brackets () are in inches (inch).

Model MTG18A - Flange type size 2.5 mm (0.1 inch) to 15 mm (1/2 inch)
- Flange type size 25 mm (1 inch)

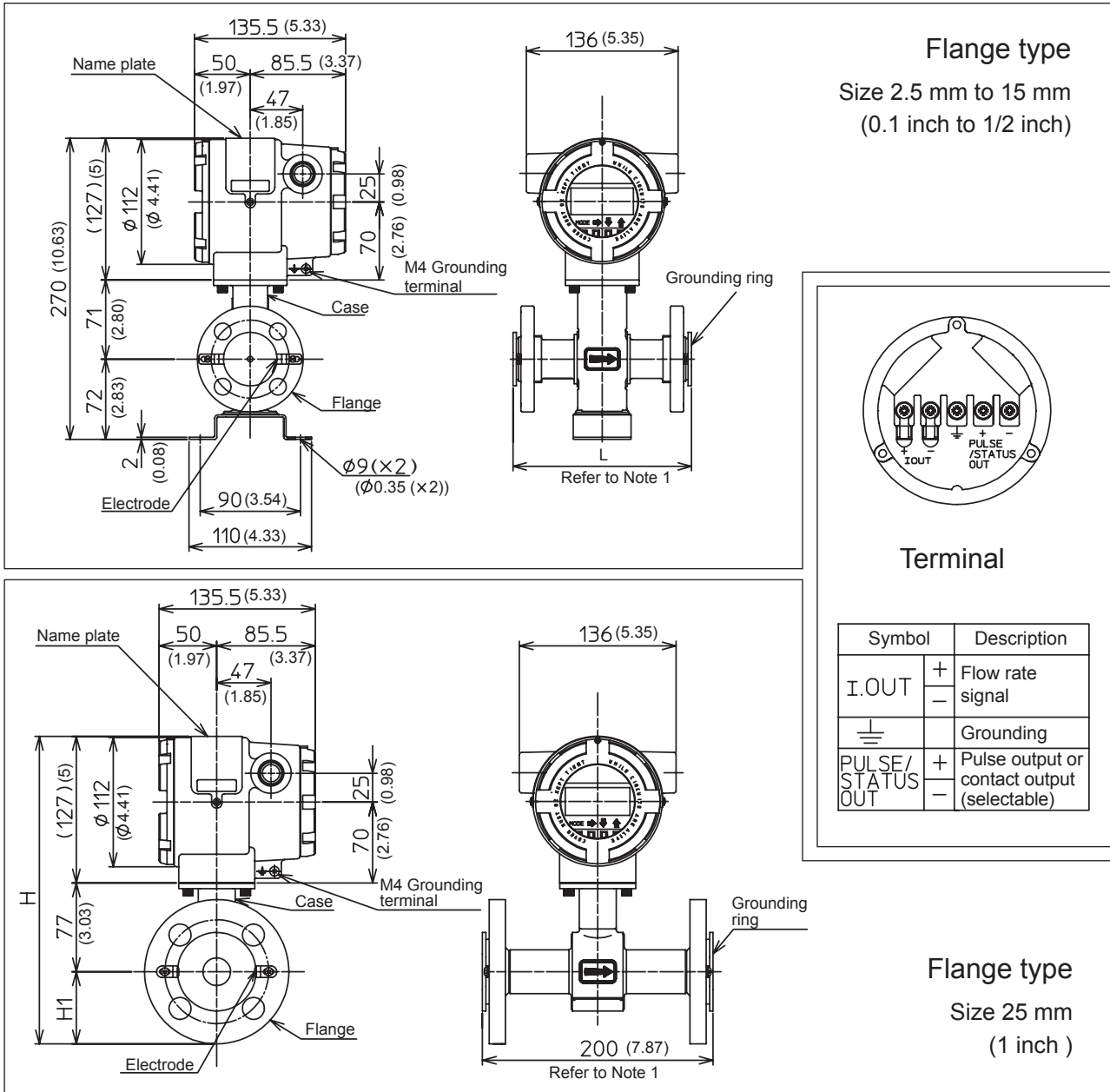

Note 1 • When grounding ring material is SUS316, gasket dimension is not included to the face-to-face dimension.
 • When grounding ring material is other than SUS316, a 3 mm of Teflon gasket dimension is included to the face-to-face dimension.

Table 1

Size mm (inch)	Model no.		J1	J2	J3	J4	J5	A1	A2	D1/D2	D3/D4
	Flange rating		JIS					ANSI		DIN	
			10K	20K	30K	10K 10 mm flange	20K 10 mm flange	150	300	PN 10/16	PN 25/40
2.5 to 10 (0.1 to 3/8)	Dimension	L	160	160	160	160	160	160 (6.3)	160 (6.3)	160	160
	Weight	(kg)	6.8	7	8	6.7	6.8	6.4 (14.1 lb)	6.9 (15.2 lb)	6.9	7.1
15 (1/2)	Dimension	L	200	200	200	200	200	200 (7.87)	200 (7.87)	200	200
	Weight	(kg)	7	7.2	8.2	6.9	7	6.6 (14.6 lb)	7.1 (15.7 lb)	7.1	7.3
25 (1)	Dimension	H	267	267	269	-	-	258 (10.16)	266 (10.47)	262	262
		H1	63	63	65	-	-	54 (2.13)	62 (2.44)	58	58
	Weight	(kg)	9.2	9.5	10.3	-	-	8.4 (18.5 lb)	9.5 (20.9 lb)	9.1	9.4

Model MTG18A - Flange type size 40 mm (1½ inch) to 100 mm (4 inches)

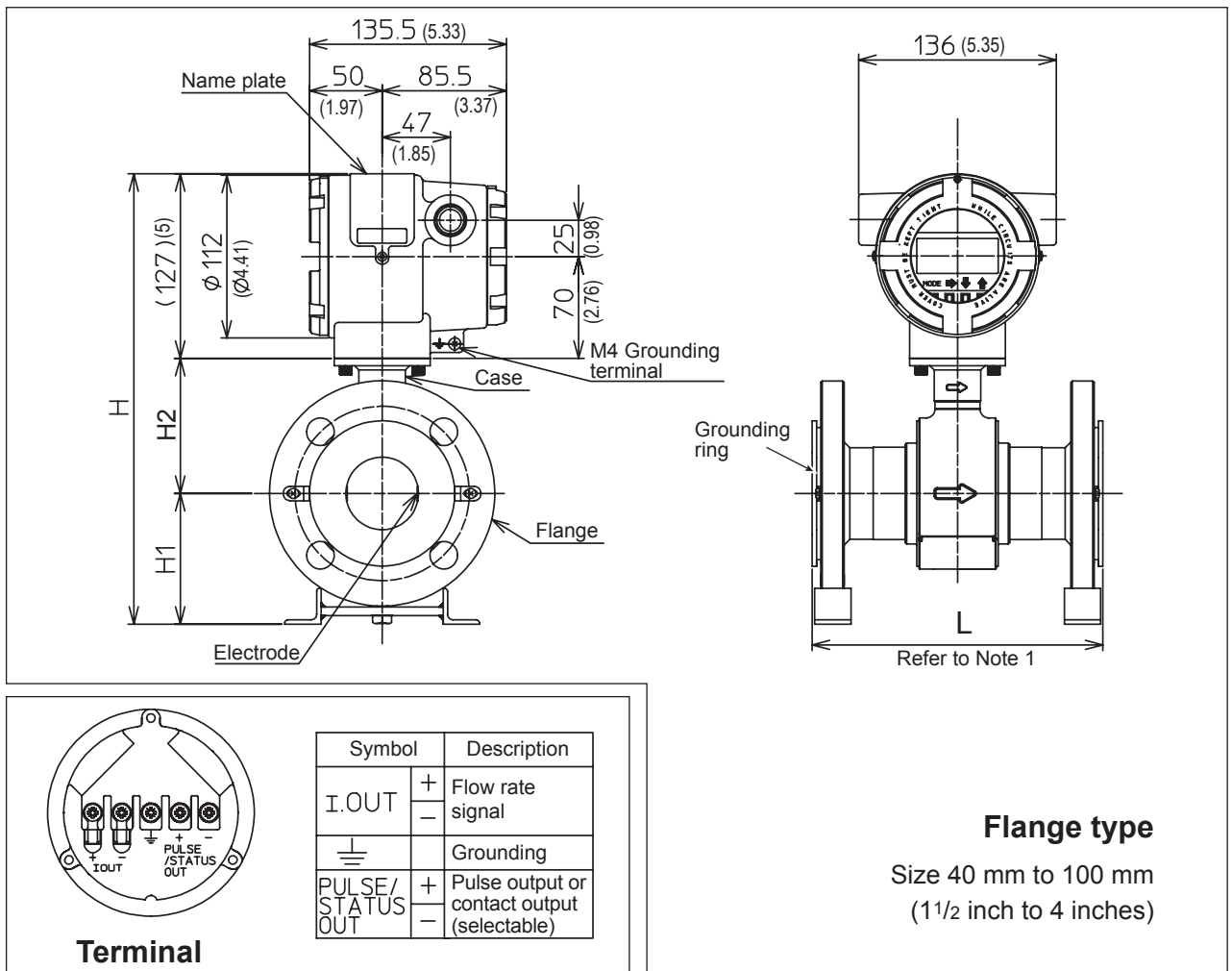

Note 1 • When grounding ring material is SUS316, gasket dimension is not included to the face-to-face dimension.
• When grounding ring material is other than SUS316, a 3 mm of Teflon gasket dimension is included to the face-to-face dimension.

Table 2

Size mm (inches)	Model no.		J1	J2	J3	A1	A2	D1/D2	D3/D4
			JIS			ANSI		DIN	
	Flange rating		10K	20K	30K	150	300	PN 10/16	PN 25/40
40 (1.5)	Dimension	L	200	200	200	200 (7.87)	200 (7.87)	200	200
		H	296	296	307	288 (11.34)	305 (12.01)	302	302
		H1	85	85	96	77 (3.03)	94 (3.7)	91	91
		H2	84	84	84	84 (3.31)	84 (3.31)	84	84
	Weight	(kg)	8.3	8.6	11	7.8 (17.2 lb)	10.1 (22.3 lb)	8.7	9.7
50 (2)	Dimension	L	200	200	200	200 (7.87)	200 (7.87)	200	200
		H	310	310	316	308 (12.13)	316 (12.44)	316	316
		H1	90	90	96	88 (3.46)	96 (3.78)	96	96
		H2	93	93	93	93 (3.66)	93 (3.66)	93	93
	Weight	(kg)	11.9	12	13.7	12.3 (27.1 lb)	13.8 (30.4 lb)	13.3	13.8
65 (2.5)	Dimension	L	200	200	200	200 (7.87)	200 (7.87)	200	200
		H	329	329	343	330 (12.99)	388 (13.31)	334	334
		H1	102	102	116	103 (4.06)	111 (4.37)	107	107
		H2	100	100	100	100 (3.94)	100 (3.94)	100	100
	Weight	(kg)	13.9	14	15.7	14.3 (31.5 lb)	15.8 (34.8 lb)	15.3	15.8
80 (3)	Dimension	L	200	200	200	200 (7.87)	200 (7.87)	200	200
		H	345	354	359	346 (13.62)	359 (14.13)	354	354
		H1	110	119	124	113 (4.45)	124 (4.88)	119	119
		H2	108	108	108	108 (4.25)	108 (4.25)	108	108
	Weight	(kg)	14.4	16.7	20.4	17.3 (38.1 lb)	21.3 (47.0 lb)	14.4	16.5
100 (4)	Dimension	L	250	250	250	250 (9.84)	250 (9.84)	250	250
		H	367.5	376.5	384.5	378.5 (14.90)	392.5 (15.45)	373.5	381.5
		H1	120	129	137	131 (5.16)	145 (5.71)	126	134
		H2	120.5	120.5	120.5	120.5 (4.74)	120.5 (4.74)	120.5	120.5
	Weight	(kg)	20.2	23.7	28.6	25.1 (55.3 lb)	34.2 (75.4 lb)	19.6	23.4

Model MTG18A - Flange type size 150 mm (6 inches) and 200 mm (8 inches)

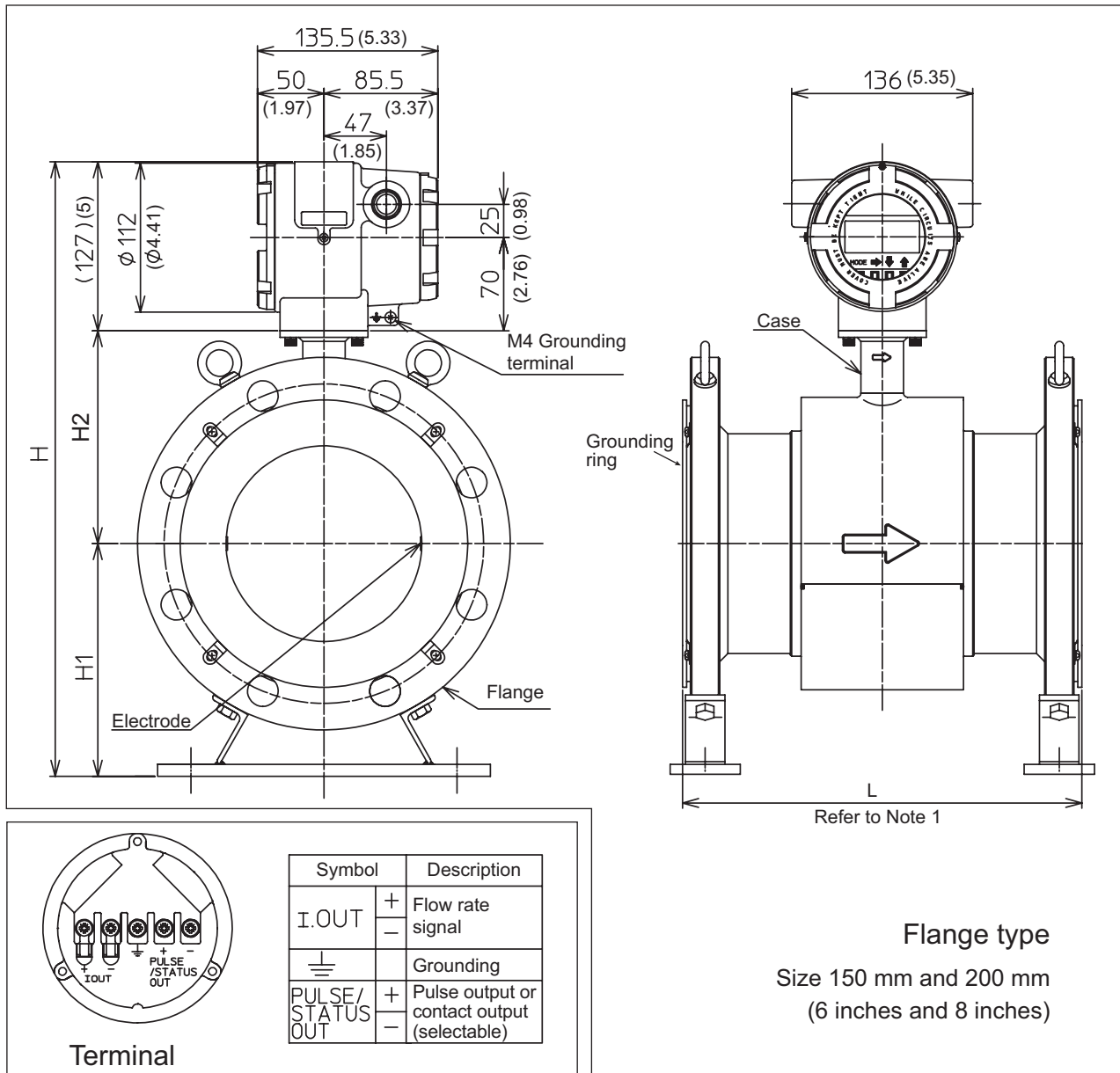

Note 1 • When grounding ring material is SUS316, gasket dimension is not included to the face-to-face dimension.
 • When grounding ring material is other than SUS316, a 3 mm of Teflon gasket dimension is included to the face-to-face dimension.

Table 3

Size mm (inches)	Model no.	J1	J2	J3	A1	A2	D1/D2	D3	D4	
							JIS			ANSI
	Flange rating	10K	20K	30K	150	300	PN 10/16	PN 25	PN40	
150 (6)	Dimension	L	300	300	300	300 (11.81)	300 (11.81)	300	300	300
		H	462	476	487	461 (18.15)	483 (19.02)	465	473	473
		H1	175	189	200	174 (6.85)	196 (7.72)	178	186	186
		H2	160	160	160	160 (6.3)	160 (6.3)	160	160	160
	Weight	(kg)	34.4	41.7	54.3	37.2 (82.0 lb)	56.2 (123.9 lb)	30.7	38.6	38.6
200 (8)	Dimension	L	350	350	350	350 (13.78)	350 (13.78)	350	350	350
		H	508	515	531	516 (20.31)	537 (21.14)	514	526	534
		H1	196	203	219	204 (8.03)	225 (8.86)	202	214	222
		H2	185	185	185	185 (7.28)	185 (7.28)	185	185	185
	Weight	(kg)	49.8	59.8	87	61.8 (136.2 lb)	90.8 (200.2 lb)	48.1	68.5	72

Model MTG18A - Wafer type size 25 mm (1 inch) to 100 mm (4 inches)

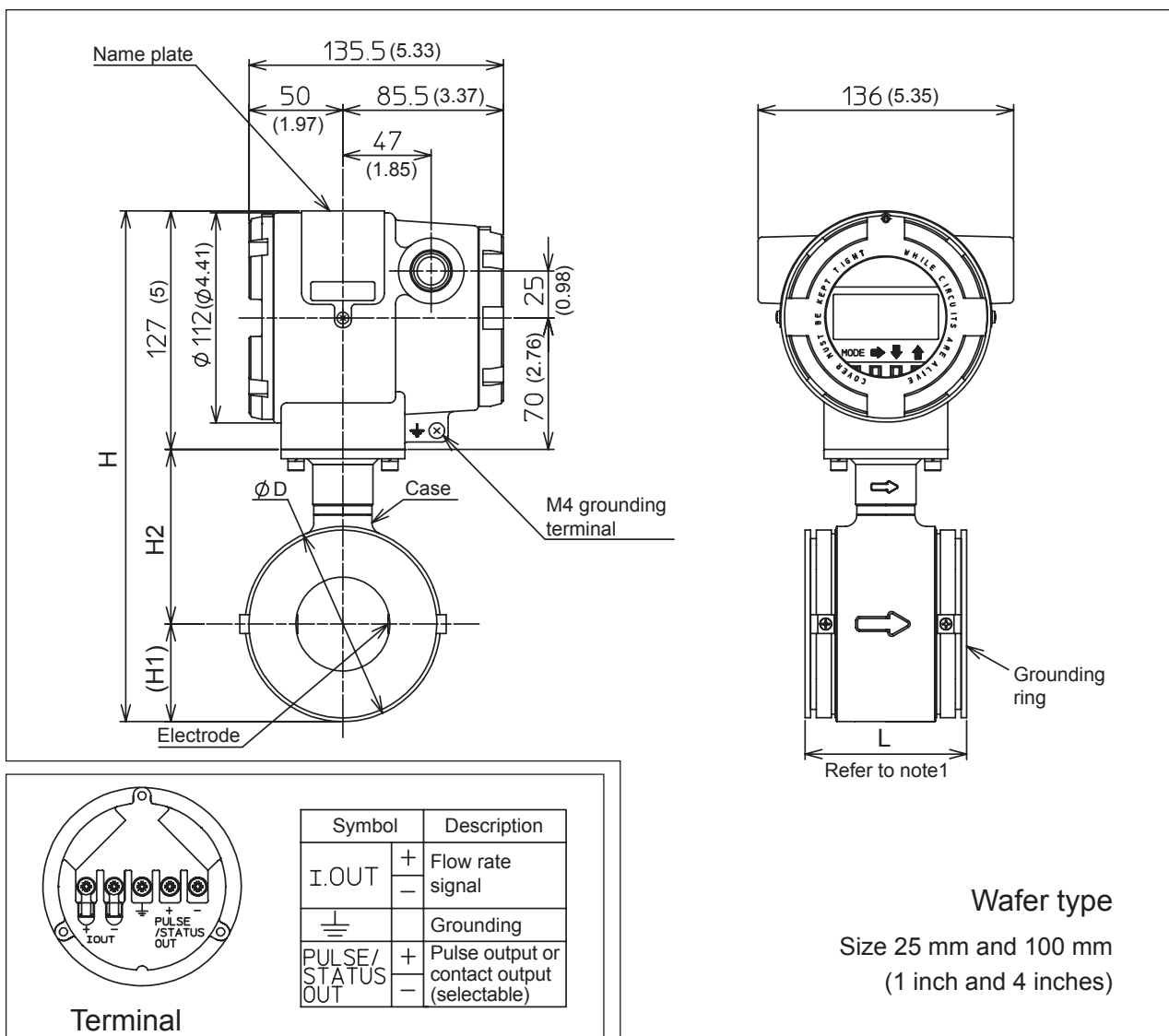

Note 1 • When grounding ring material is SUS316, gasket dimension is not included to the face-to-face dimension.
 • When grounding ring material is other than SUS316, a 3 mm of Teflon gasket dimension is included to the face-to-face dimension.

Table 4

Flange rating	25 mm (1 inch)	40 mm (1½ inch)		50 mm (2 inches)		65 mm (2½ inches)	80 mm (3 inches)		100 mm (4 inches)		
	A	A	S	A	S	A	A	S	A	S	
Dimension size	L	94 (3.7)	80 (3.15)	98 (3.86)	86 (3.39)	104 (4.09)	96 (3.78)	106 (4.17)	130 (5.12)	120 (4.72)	150 (5.91)
	H	238 (9.37)	254.5 (10.02)		272 (10.71)		289 (11.38)	302 (11.89)		327 (12.87)	
	H1	34 (1.34)	43.5 (1.71)		52 (2.05)		62 (2.44)	67 (2.64)		79.5 (3.13)	
	H2	77 (3.03)	84 (3.31)		93 (3.66)		100 (3.94)	108 (4.25)		120.5 (4.74)	
	D	68 (2.68)	87 (3.43)		104 (4.09)		124 (4.88)	134 (5.28)		159 (6.26)	
Weight	(kg)	3.7	3.8	4.3	4.4	5.0	5.5	6.4	7.1	8.2	9.2
		(8.2 lb)	(8.4 lb)	(9.5 lb)	(9.7 lb)	(11.0 lb)	(12.1 lb)	(14.1 lb)	(15.7 lb)	(18.1 lb)	(20.3 lb)

Model MTG14C - Converter

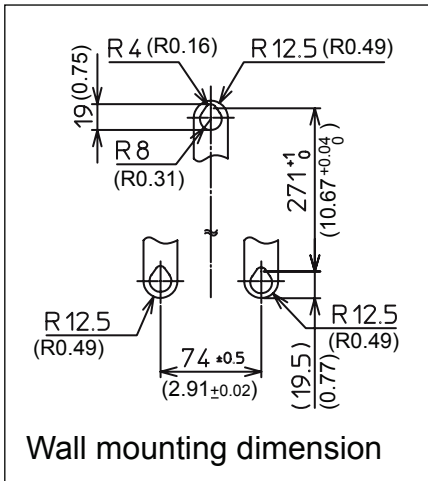

Wall mounting dimension

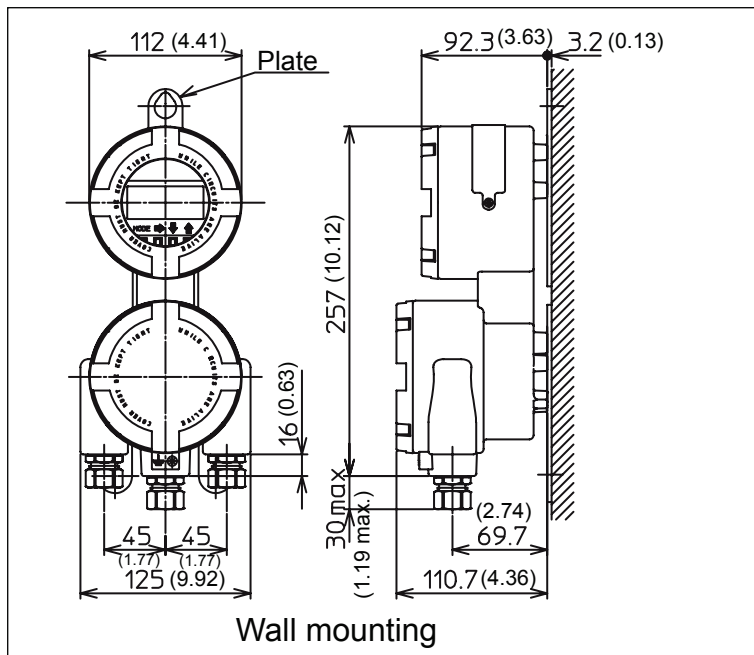

Wall mounting

Terminal

Symbol	Description
I-OUT $\begin{matrix} + \\ - \end{matrix}$	Flow rate signal
---	Grounding
PULSE/STATUS OUT $\begin{matrix} + \\ - \end{matrix}$	Pulse output or contact (selectable)
X	Excitation output
Y	
A	Flow rate signal input
B	
C	

* Terminal screw: M4

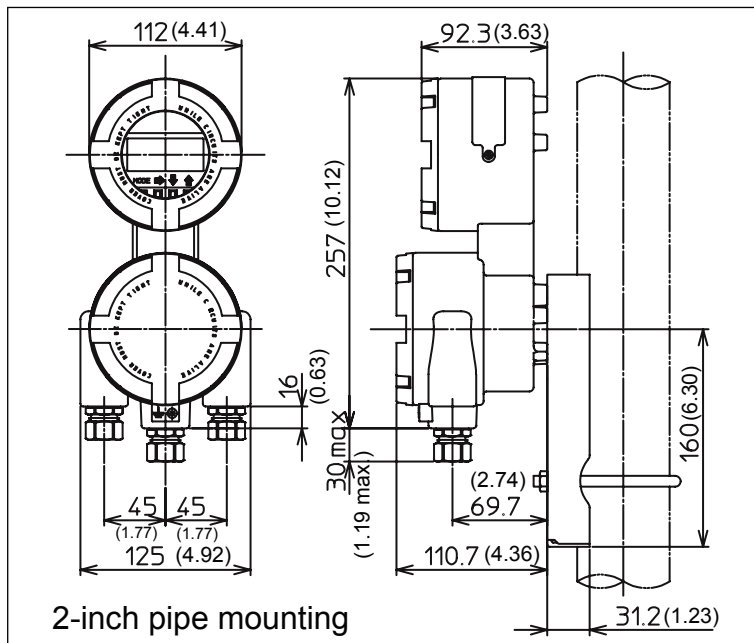

2-inch pipe mounting

Model SMC11 - Cable

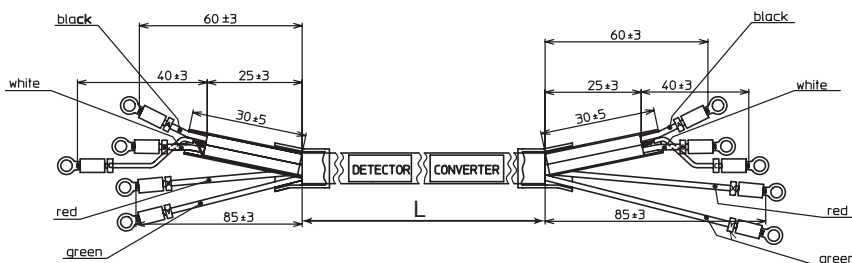

L: Cable length

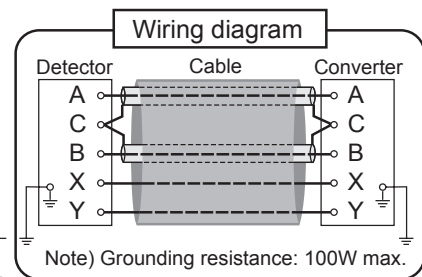

**Model MTG18B - Detector - Flange type size 10 mm (3/8 inch) and 15 mm (1/2 inch)
- Flange type size 25 mm (1 inch)**

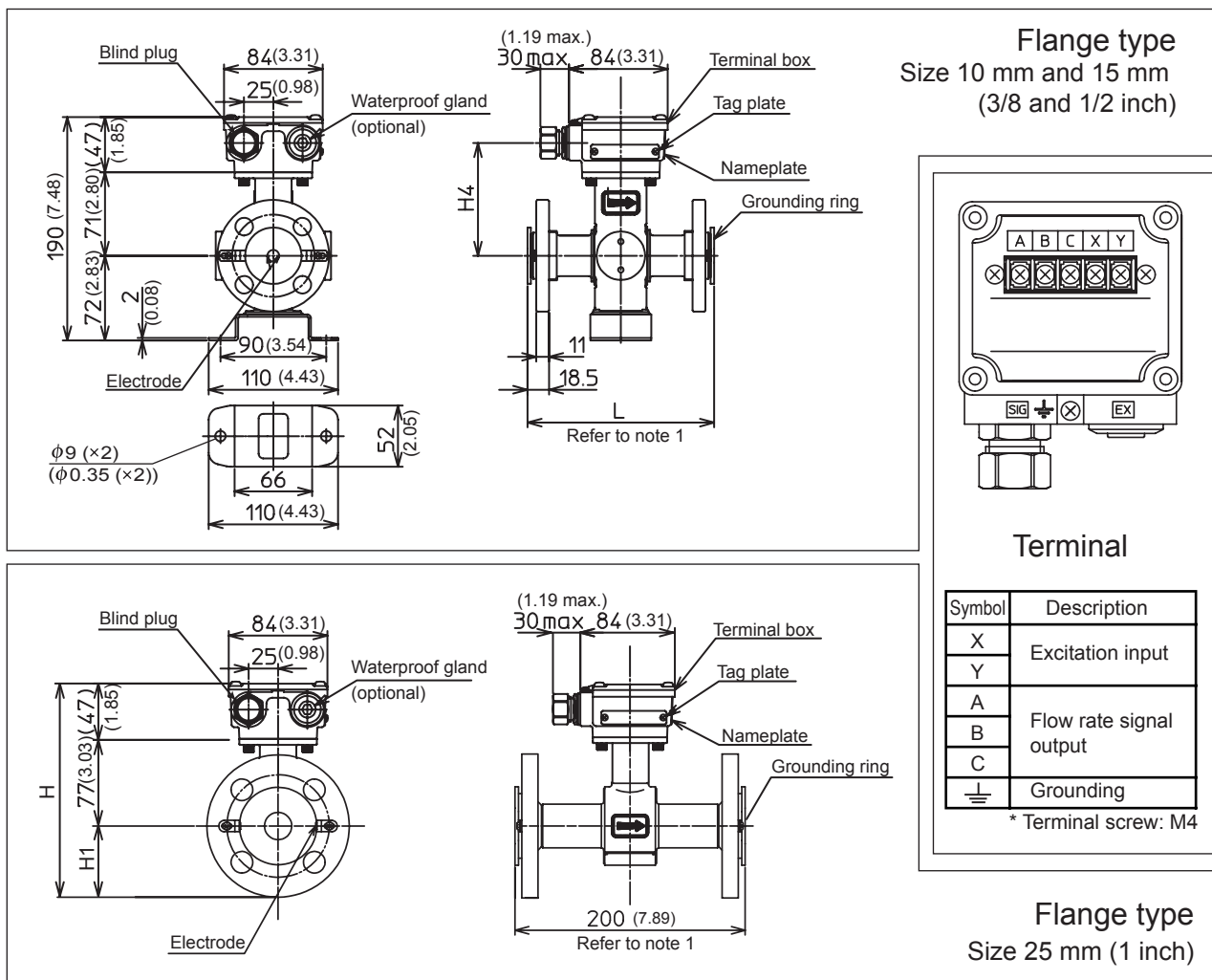

Note 1 • When grounding ring material is SUS316, gasket dimension is not included to the face-to-face dimension.
• When grounding ring material is other than SUS316, a 3 mm of Teflon gasket dimension is included to the face-to-face dimension.

Table 5

Size mm (inches)	Model no.		J1	J2	J3	J4	J5	A1	A2	D1/D2	D3/D4
	Flange rating		JIS					ANSI		DIN	
			10K	20K	30K	10K 10 mm flange	20K 10 mm flange	150	300	PN 10/16	PN 25/40
10 (3/8)	Dimension	L	160	160	160	160	160	160 (6.3)	160 (6.3)	160	160
	Weight	(kg)	5	5.2	6.2	4.9	5	4.6 (10.1 lb)	5.1 (11.2 lb)	5.1	5.3
15 (1/2)	Dimension	L	200	200	200	200	200	200 (7.87)	200 (7.87)	200	200
	Weight	(kg)	5.2	5.4	6.4	5.1	5.2	4.8 (10.6 lb)	5.3 (11.7 lb)	5.3	5.5
25 (1)	Dimension	H	187	187	189	-	-	188 (7.4)	186 (7.32)	182	182
		H1	63	63	65	-	-	54 (2.13)	62 (2.44)	58	58
	Weight	(kg)	7.4	7.7	8.5	-	-	6.6 (14.6 lb)	7.7 (17.0 lb)	7.3	7.6

Model MTG18B - Detector - Flange type size 40 mm (1½ inch) to 100 mm (4 inches)

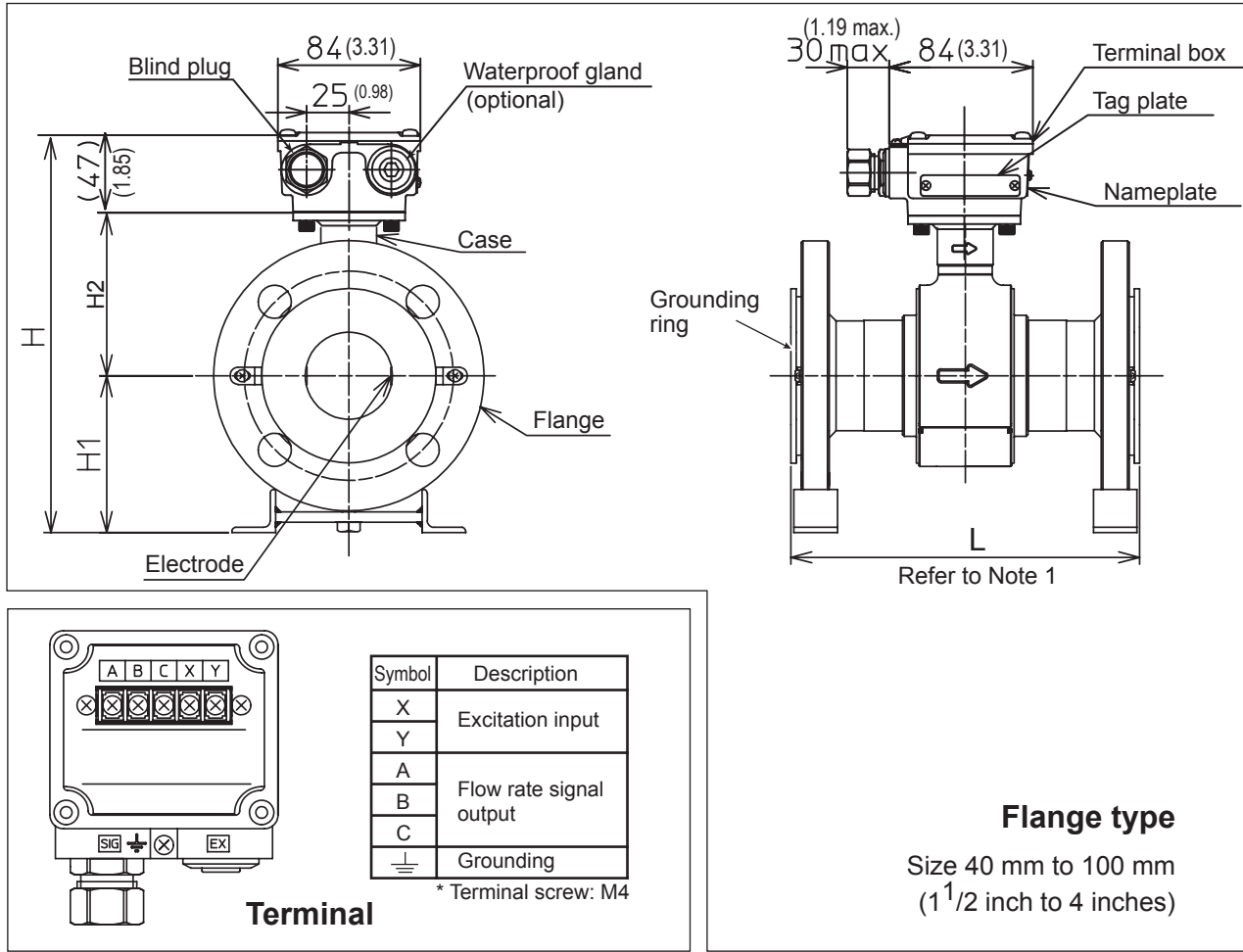

Note 1 • When grounding ring material is SUS316, gasket dimension is not included to the face-to-face dimension.
 • When grounding ring material is other than SUS316, a 3 mm of Teflon gasket dimension is included to the face-to-face dimension.

Table 6

Size mm (inches)	Model no. Flange rating	JIS			ANSI		DIN		
		J1	J2	J3	A1	A2	D1/D2	D3/D4	
		10K	20K	30K	150	300	PN 10/16	PN 25/40	
40 (1.5)	Dimension	L	200	200	200	200 (7.87)	200 (7.87)	200	200
		H	216	216	227	208 (8.19)	225 (8.86)	222	222
		H1	85	85	96	77 (3.03)	94 (3.7)	91	91
		H2	84	84	84	84 (3.31)	84 (3.31)	84	84
	Weight	(kg)	6.5	6.8	9.2	6 (13.2 lb)	8.3 (18.3 lb)	6.9	7.9
50 (2)	Dimension	L	200	200	200	200 (7.87)	200 (7.87)	200	200
		H	230	230	236	228 (8.98)	236 (9.29)	236	236
		H1	90	90	96	88 (3.46)	96 (3.78)	96	96
		H2	93	93	93	93 (3.66)	93 (3.66)	93	93
	Weight	(kg)	10.1	10.2	11.9	10.5 (23.1 lb)	12 (26.5 lb)	11.5	12
65 (2.5)	Dimension	L	200	200	200	200 (7.87)	200 (7.87)	200	200
		H	249	249	263	250 (9.84)	258 (10.16)	254	254
		H1	102	102	116	103 (4.06)	111 (4.37)	107	107
		H2	100	100	100	100 (3.94)	100 (3.94)	100	100
	Weight	(kg)	12.1	12.2	13.9	12.5 (27.6 lb)	14 (30.9 lb)	13.5	14
80 (3)	Dimension	L	200	200	200	200 (7.87)	200 (7.87)	200	200
		H	265	274	279	266 (10.47)	279 (10.98)	274	274
		H1	110	119	124	113 (4.45)	124 (4.88)	119	119
		H2	108	108	108	108 (4.25)	108 (4.25)	108	108
	Weight	(kg)	16.6	14.9	18.6	15.5 (34.2 lb)	19.5 (43.0 lb)	12.6	14.7
100 (4)	Dimension	L	250	250	250	250 (9.84)	250 (9.84)	250	250
		H	287.5	296.5	304.5	298.5 (11.75)	312.5 (12.30)	293.5	301.5
		H1	120	129	137	131 (5.16)	145 (5.71)	126	134
		H2	120.5	120.5	120.5	120.5 (4.74)	120.5 (4.74)	120.5	120.5
	Weight	(kg)	18.4	21.9	26.8	23.3 (51.4 lb)	32.4 (71.4 lb)	17.8	21.6

Model MTG18B - Detector - Flange type size 150 mm (6 inches) and 200 mm (8 inches)

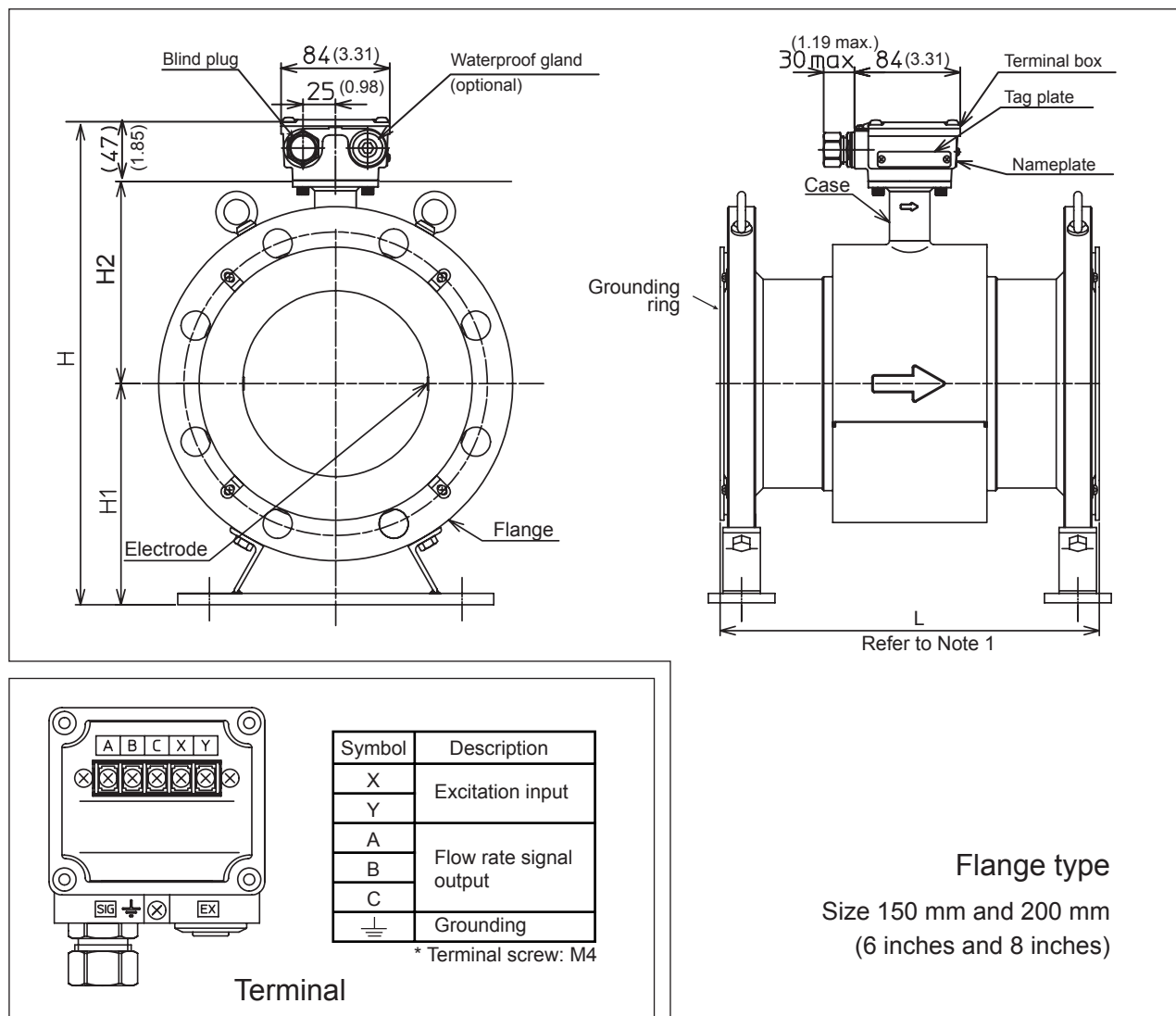

Note 1 • When grounding ring material is SUS316, gasket dimension is not included to the face-to-face dimension.
• When grounding ring material is other than SUS316, a 3 mm of Teflon gasket dimension is included to the face-to-face dimension.

Table 7

Size mm (inches)	Model no.	Flange rating	J1	J2	J3	A1	A2	D1/D2	D3	D4
			JIS			ANSI		DIN		
			10K	20K	30K	150	300	PN 10/16	PN 25	PN 40
150 (6)	Dimension	L	300	300	300	300 (11.81)	300 (11.81)	300	300	300
		H	382	396	407	381 (15)	403 (15.87)	385	393	393
		H1	175	189	200	174 (6.85)	196 (7.72)	178	186	186
		H2	160	160	160	160 (6.3)	160 (6.3)	160	160	160
	Weight	(kg)	32.6	39.9	52.5	35.4 (78 lb)	54.4 (119.9 lb)	28.9	36.8	36.8
200 (8)	Dimension	L	350	350	350	350 (13.78)	350 (13.78)	350	350	350
		H	428	435	451	436 (17.17)	457 (17.99)	434	446	454
		H1	196	203	219	204 (8.03)	225 (8.86)	202	214	222
		H2	185	185	185	185 (7.28)	185 (7.28)	185	185	185
	Weight	(kg)	48	58	85.2	60 (132.3 lb)	89 (196.2 lb)	46.3	66.7	70.2

Model MTG18B - Detector - Wafer type size 25 mm (1 inch) to 100 mm (4 inches)

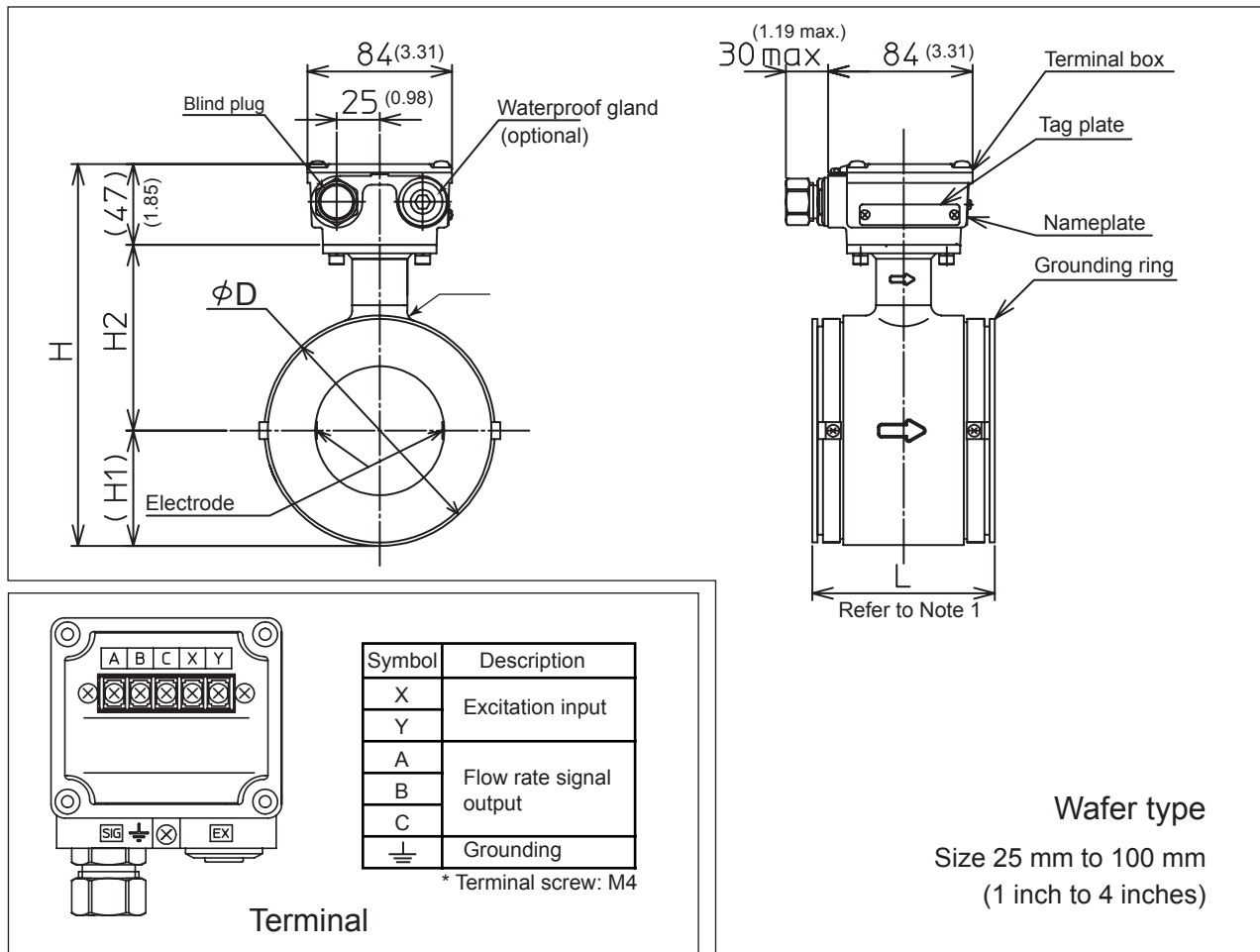

Note 1 • When grounding ring material is SUS316, gasket dimension is not included to the face-to-face dimension.
 • When grounding ring material is other than SUS316, a 3 mm of Teflon gasket dimension is included to the face-to-face dimension.

Table 8

Flange rating	25 mm (1 inch)		40 mm (1½ inch)		50 mm (2 inches)		65 mm (2½ inches)		80 mm (3 inches)		100 mm (4 inches)	
	A		A	S	A	S	A	A	S	A	S	
Dimension size	L	94 (3.7)	80 (3.15)	98 (3.86)	86 (3.39)	104 (4.09)	96 (3.78)	106 (4.17)	130 (5.12)	120 (4.72)	150 (5.91)	
	H	158 (6.22)	174.5 (6.87)		192 (7.56)		209 (8.23)	222 (8.74)		247 (9.72)		
	H1	34 (1.34)	43.5 (1.71)		52 (2.05)		62 (2.44)	67 (2.64)		79.5 (3.13)		
	H2	77 (3.03)	84 (3.31)		93 (3.66)		100 (3.94)	108 (4.25)		120.5 (4.74)		
	D	68 (2.68)	87 (3.43)		104 (4.09)		124 (4.88)	134 (5.28)		159 (6.26)		
Weight	(kg)	2	2	2.5	2.6	3.2	3.7	4.6	5.3	6.4	7.4	
		(4.4 lb)	(4.4 lb)	(5.5 lb)	(5.7 lb)	(7.1 lb)	(8.2 lb)	(10.1 lb)	(11.7 lb)	(14.1 lb)	(16.3 lb)	

