

**Smart Two-wire
Electromagnetic Flowmeter
JIS Explosion-protected Apparatus
Model: MTG15A**

User's Manual



Yamatake Corporation

Copyright, Notices and Trademarks

Printed in Japan - ©Copyright 2005 by Yamatake Corporation.

While this information is presented in good faith and believed to be accurate, Yamatake Corporation disclaims the implied warranties of merchantability and fitness for a particular purpose and makes no express warranties except as may be stated in its written agreement with and for its customer.

In no event is Yamatake Corporation liable to anyone for any indirect, special or consequential damages. This information and specifications in this document are subject to change without notice.

Preface

Thank you for purchasing our smart two-wire electromagnetic flowmeter. The model MTG is an epoch-making electromagnetic flowmeter that is operated on 4-20mA DC. Based on our extensive experience in the field, meticulous care is taken in the detector lining material and waterproofing properties to secure high reliability.

Unpacking and inspection

Unpacking

This flowmeter is a precision instrument. When unpacking, handle it with care to prevent accidents or damage. Check that the following items are contained:

MTG main unit, standard accessories and SETTING DATA sheet

Verifying the specifications

The specifications are written on the nameplate of the main unit. Referring to Appendix A, check that these are consistent with your specifications. Check the following items, in particular:

(Main unit)

- Detector bore diameter
- Electrode material
- Flange rating
- Grounding ring material

Inquiries

If you have any questions regarding the specifications, contact the nearest Yamatake Corporation office or Yamatake Corporation representative. When making an inquiry, be sure to provide the MODEL NO. and PRODUCT NO.

Storage precautions

When storing this instrument before use, observe the following instructions:

- Store it indoors and at room temperature and humidity in a place safe from vibration or shock.
- Store it in its packed and shipped state.

When storing this instrument after usage, observe the following instructions:

1. Rinse the inside of the detector with water to remove the adhering measured fluid and dry off the water.
2. Tighten the display cover and terminal box cover. This prevents humidity from getting in.
3. Return the instrument to its shipped, packed state.
4. Store it indoors at room temperature and humidity in a place from vibration and shock.

Usage precautions

In this manual, the following symbols are used for safe instrument use.



WARNING

If the user handles the instrument incorrectly, it may give rise to a dangerous situation that results in death or serious injury to the user. This symbol refers to warnings to avoid such danger.



CAUTION

If the user handles the instrument incorrectly, it may give rise to a dangerous situation that results in slight injury to the user or physical damage to property alone. This symbol refers to cautions to avoid such danger.

How this Manual is organized and used

Organization and method of use

This manual explains how to use model MTG and related equipment in the following order:

Chapter 1

Explains the configuration of measuring systems using this instrument and describes the names and functions of various parts of the instrument.

Chapter 2

Describes instrument installation. The persons in charge of installation and piping should refer to this chapter.

Chapter 3

Describes the wiring and connections. The persons in charge of wiring work should refer to this chapter.

Chapter 4

Describes the procedure to start, operate and stop this instrument.

Chapter 5

To manipulate the instrument, either its data setter or a communication line may be used. In this manual, the data setter is taken up.

Read this chapter when starting the instrument after installation or when stopping its operation.

Chapter 6

Describes the procedures that are necessary for maintenance, inspection and troubleshooting of the instrument.

Use this chapter when searching for an explanation necessary for maintenance or troubleshooting.

Appendix A

Gives the specifications of the instrument.

This manual explains how to use the instrument and related equipment in the following order:

Table of Contents

Chapter 1 : Measuring configuration system and model MTG structure

1-1 : System configuration	1-2
Measuring system.....	1-2
System configuration 1 for analog output	1-4
System configuration for digital output (DE output)	1-5
System configuration for pulse output.....	1-6
System configuration for contact output.....	1-7
1-2 : JIS Explosion-protected apparatus	1-8
1-3 : Structure of this instrument and functions of its various parts	1-9
Structure of main unit.....	1-9
Detector 1: Flanged type.....	1-10
Detector 2: Wafer type	1-11
Indicator / data setter	1-12
Terminal box	1-13

Chapter 2 : Installing the model MTG

2-1 : Before installation	2-2
Criteria (1) for installation location	2-2
Criteria (2) for installation location	2-4
Direction of display/data setter.....	2-6
2-2 : Method of Installation.....	2-7
2-2-1 : Installing a safer type detector.....	2-7
Basic installation method	2-7
Accessory parts for installation	2-10
Selecting an installation method	2-12
Installation on horizontal pipe	2-13
Installation on vertical pipe	2-14
Installation on metal pipe (1).....	2-16
Installation on metal pipe (2).....	2-17
Installation on PVC pipe (1)	2-18
Installation on PVC pipe (2).....	2-20
2-2-2 : Installation a flange type detector.....	2-22
Basic installation method	2-22
Accessory parts for installation	2-25
Selecting an installation method	2-26
Installation on metal pipe (1).....	2-27
Installation on metal pipe (2).....	2-28
Installation on PVC pipe (1)	2-29
Installation on PVC pipe (2).....	2-32

Table of Contents

Chapter 3 : Electrical wiring

3-1 : Electrical wiring	3-2
Electrical wiring	3-2

Chapter 4 : Start and stop operation procedure for model MTG

4-1 : Confirmation before start	4-2
4-2 : Stopping.....	4-3

Chapter 5 : Operation using the data setting device

5-1 : Startup	5-2
5-2 : Functions of the data setting device	5-5
5-2-1 : Data setting device	5-5
5-3 : Description of MEASURING MODE	5-7
5-3-1 : Display overview.....	5-7
5-3-2 : Display of write protect level.....	5-8
5-4 : Overview of operation using the data setting device	5-10
5-5 : Configuration of OPERATOR'S MODE.....	5-11
5-5-1 : Changing setting of damping time constant	5-13
5-5-2 : Auto zero adjustment.....	5-14
5-5-3 : Setting of built-in counter reset value	5-15
5-5-4 : Setting of built-in counter reset value	5-16
5-5-5 : Setting auto spike cut	5-17
5-5-6 : Setting moving average processing	5-18
5-5-7 : Setting empty pipe detection	5-20
5-5-8 : Selecting flow rate to be displayed in the main display	5-27
5-5-9 : Selecting a communication system	5-28
5-5-10 : Entering ENGINEERING MODE and MAINTENANCE MODE	5-30
5-6 : Configuration of ENGINEERING MODE.....	5-32
5-6-1 : Setting ID.....	5-35
5-6-2 : Selecting pulse output or contact output	5-36
5-6-3 : Setting detector information.....	5-37
5-6-4 : Setting flow rate range.....	5-38
5-6-5 : Setting and changing compensation coefficient	5-39
5-6-6 : Setting specific gravity.....	5-40
5-6-7 : Setting pulse scale	5-41
5-6-8 : Setting pulse width	5-43
5-6-9 : Setting drop out	5-46
5-6-10 : Setting low flow cutoff.....	5-47
5-6-11 : Setting upper and lower limit alarm	5-48
5-6-12 : Selecting failsafe mode for analog outputs.....	5-49
5-6-13 : Selecting failsafe mode for pulse output.....	5-50
5-6-14 : Setting contact output status	5-51

Table of Contents

5-7 : Configuration of MAINTENANCE MODE.....	5-52
5-7-1 : Configuration of OUTPUT CHECK MODE	5-53
5-7-2 : Performing loop checks of analog outputs	5-54
5-7-3 : Performing loop checks of pulse outputs.....	5-55
5-7-4 : Performing loop checks of contact outputs.....	5-56
5-7-5 : Configuration of CALIBRATION MODE	5-57
5-7-6 : Configuration of CRITICAL MODE	5-60
5-7-7 : Displaying ROM version and date	5-61
5-7-8 : Returning to settings at shipment	5-62
5-8 : Description of Error Messages.....	5-63

Chapter 6 : Maintenance and troubleshooting

6-1 : Maintenance and inspection of hardware	6-2
Replacement of indicator/data setter	6-2
6-2 : Troubleshooting	6-3
Types of troubles	6-3
Troubles at startup.....	6-4
Trouble during operation.....	6-5

Table of Contents

List of Figure

Figure 1-1	Conceptual drawing of measuring system (integral type)	1-2
Figure 1-2	System configuration for analog output	1-4
Figure 1-3	System configuration for digital output	1-5
Figure 1-4	System configuration for pulse output	1-6
Figure 1-5	System configuration for contact output	1-7
Figure 1-6	Nameplate	1-8
Figure 1-7	Overview of integral type	1-9
Figure 1-8	Detector details (Flanged detector)	1-10
Figure 1-9	Detector details (wafer-type detector)	1-11
Figure 1-10	Indicator/data setter details	1-12
Figure 1-11	Terminal box details	1-13
Figure 1-12		1-14
Figure 2-1	Example of installation	2-4
Figure 2-2	Straight pipe section upstream of detector (D: Nominal detector bore diameter)	2-4
Figure 2-3	Maintenance space	2-5
Figure 2-4	Changing the display / data setter direction	2-6
Figure 2-5	Device installation example	2-7
Figure 2-6	Flange shape	2-8
Figure 2-7	Examples of unacceptable installations (1)	2-9
Figure 2-8	Examples of unacceptable installations (2)	2-9
Figure 2-9	Horizontal centering of the detector (Position two centering bushings against each flange)	2-10
Figure 2-10	Vertical centering of the detector (Position the four centering bushings on the bottom flange)	2-10
Figure 2-11	Installation using SUS material grounding ring and metal pipe	2-16
Figure 2-12	Installation using Non-SUS material grounding ring and metal pipe	2-17
Figure 2-13	Example of incorrect installation	2-17
Figure 2-14	Installation using SUS material grounding ring	2-18
Figure 2-15	Installation using SUS material grounding ring (with protective plate)	2-19
Figure 2-16	Installation using SUS material grounding ring (with rubber gasket)	2-19
Figure 2-17	Installation using the grounding ring of Non-SUS material	2-20
Figure 2-18	Installation using the grounding ring of Non-SUS material (with protective plate)	2-21
Figure 2-19	Installation using the grounding ring of Non-SUS material (with rubber gasket)	2-21
Figure 2-20	Installation example	2-22
Figure 2-21	Flange shape	2-24
Figure 2-22	Example of incorrect mounting	2-24
Figure 2-23	Installation using grounding rings of SUS material	2-27
Figure 2-24	Installation using grounding ring made of Non-SUS material	2-28
Figure 2-25	Example of incorrect installation	2-28
Figure 2-26	Installation using SUS material grounding ring	2-30
Figure 2-27	Detector installation using SUS material grounding ring (with protective plate)	2-30
Figure 2-28	Detector installation using SUS material grounding ring (with rubber gasket)	2-31
Figure 2-29	Detector installation using Non-SUS material grounding ring	2-32
Figure 2-30	Detector installation using Non-SUS material grounding ring (with protective plate)	2-33
Figure 2-31	Detector installation using Non-SUS material grounding ring (with rubber gasket)	2-33

List of Figure

Figure 3-1	Supply power voltage-load resistance characteristics.....	3-2
Figure 3-2	3-4
Figure 3-3	3-4
Figure 3-4	Installation method of JIS Intrinsically Safe.....	3-5
Figure 3-5	Wire connection diagram.....	3-6
Figure 3-6	Pulse output wire connection diagram.....	3-6
Figure 3-7	Contact output wire connection diagram.....	3-7
Figure 3-8	Wiring for power supply.....	3-8
Figure 5-1	Damping output characteristics.....	5-13
Figure 5-2	Auto spike cut output characteristics.....	5-17
Figure 5-3	Output characteristics of moving average processing.....	5-18
Figure 6-1	Replacement of indicator/data setter (with the cover removed).....	6-2

List of Table

Table 2-1	Fastening torque levels.....	2-8
Table 2-2	Recommended internal diameters of gaskets (Unit: mm)	2-11
Table 2-3	Internal and external diameters of rubber gaskets (0.5 to 1 mm thick) (Unit: mm)	2-11
Table 2-4	Internal and external diameter of rubber gaskets (3 to 4 mm thick) (Unit: mm)	2-11
Table 2-5	Fastening torque (1)	2-23
Table 2-6	Recommended internal diameters of gaskets.....	2-25
Table 5-1	Set levels for empty pipe detection	5-21

Chapter 1 : Measuring configuration system and model MTG structure

Outline of this chapter

This chapter presents the equipment configuration of a measuring system using this instrument.

It also describes the structure and the names and functions of various parts of the main unit.

1-1 : System configuration

Measuring system

Introduction

This instrument is a two-wire electromagnetic flowmeter operated on 4-20mA DC. It measures the flow rate of conductive fluid flowing in the detector and outputs a signal that is suitable for the measuring range.

Concept of flow rate measurement by this instrument

The concept of a flow rate measuring system using this instrument is shown.

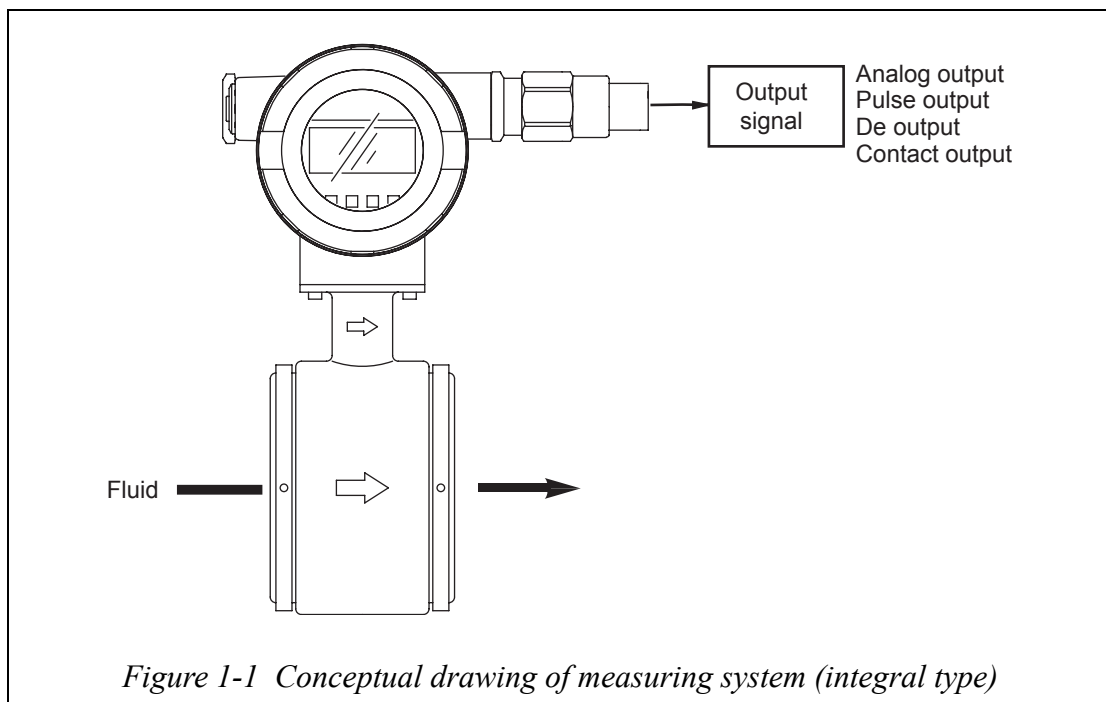

Analog output

If instantaneous flow rate values are to be output as an analog variable to control equipment, configure the system to output an analog output.

Digital output (DE output)

Use this system configuration if instantaneous flow rate values, instrument database and self-diagnosis results are to be outputted as digital variables (DE outputs) to control equipment.

Pulse output

As a pulse output, the open-collector output is available. Pulse frequencies up to 200 Hz can be outputted. The pulse output can be outputted simultaneously with an analog output.

If integrated flow values are to be outputted as a pulse to control equipment, wire an another two-wire to output a pulse output.

Contact output

Instead of the pulse output, a contact output the open-collector output is available. The contact output can be outputted simultaneously with an analog output.

System configuration 1 for analog output

System configuration

An example of system configuration is shown. The instantaneous flow rate values measured by this instrument are outputted as a 4-20mA DC analog signal.

In this system configuration, the analog signal from the instrument can be outputted directly to a host control system.

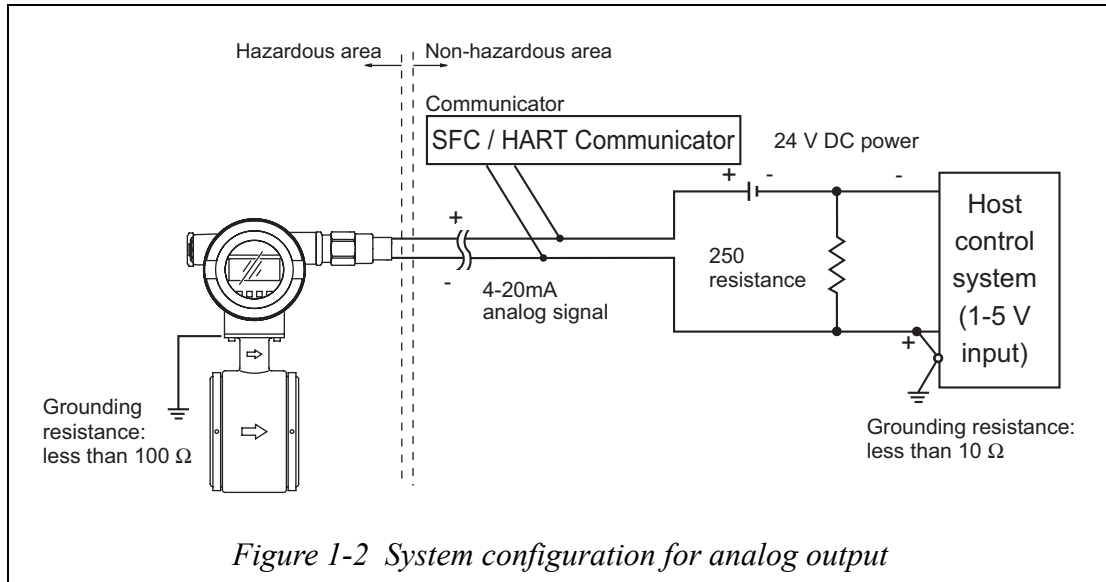

- Smart two-wire electromagnetic flowmeter (main unit): Measures flow rate and outputs instantaneous flow rate value as an analog signal.
- Communicator: Used to communicate with this instrument, read data and change the instrument data settings.

~Note

- To use the SFC, read the instruction manual CM2-MTG100-2002.
- To use the HART communicator, read the instruction manual CM2-MTG100-2002.
- Compatible with the SFC of Ver 7.0 or over. However, some functions on the main unit cannot be set.
- For DD (device description) of the HART[®] Communicator, use the HCF DD Library Host DD Distribution (HCF-KIT-III) Release 2002 Number 3 or later.
- This instrument can communicate on two protocols: Smart Field Communication (SFC) and HART[®] communication (HART[®] communicator). The communication method to be used is selected by the (human) data setter.

When configuring a system using this instrument, it is necessary to determine the power supply voltage and load resistance to satisfy the operation conditions of this instrument.

For details, refer to specification sheet (SS2-MTG100-0300).

System configuration for digital output (DE output)

System configuration

In the system configuration shown below, the flow rate measurements, database and self-diagnosis results of this instrument are outputted on the DE (digital enhancement) protocol, which is a communication protocol for digital signals.

In this system configuration, the instrument transmits digital signals on the DE protocol and the smart protocol converter (SPC) converts the digital signals into analog signals, which is outputted to a control system. It can also output the DE protocol based digital signals without conversion to a control system.

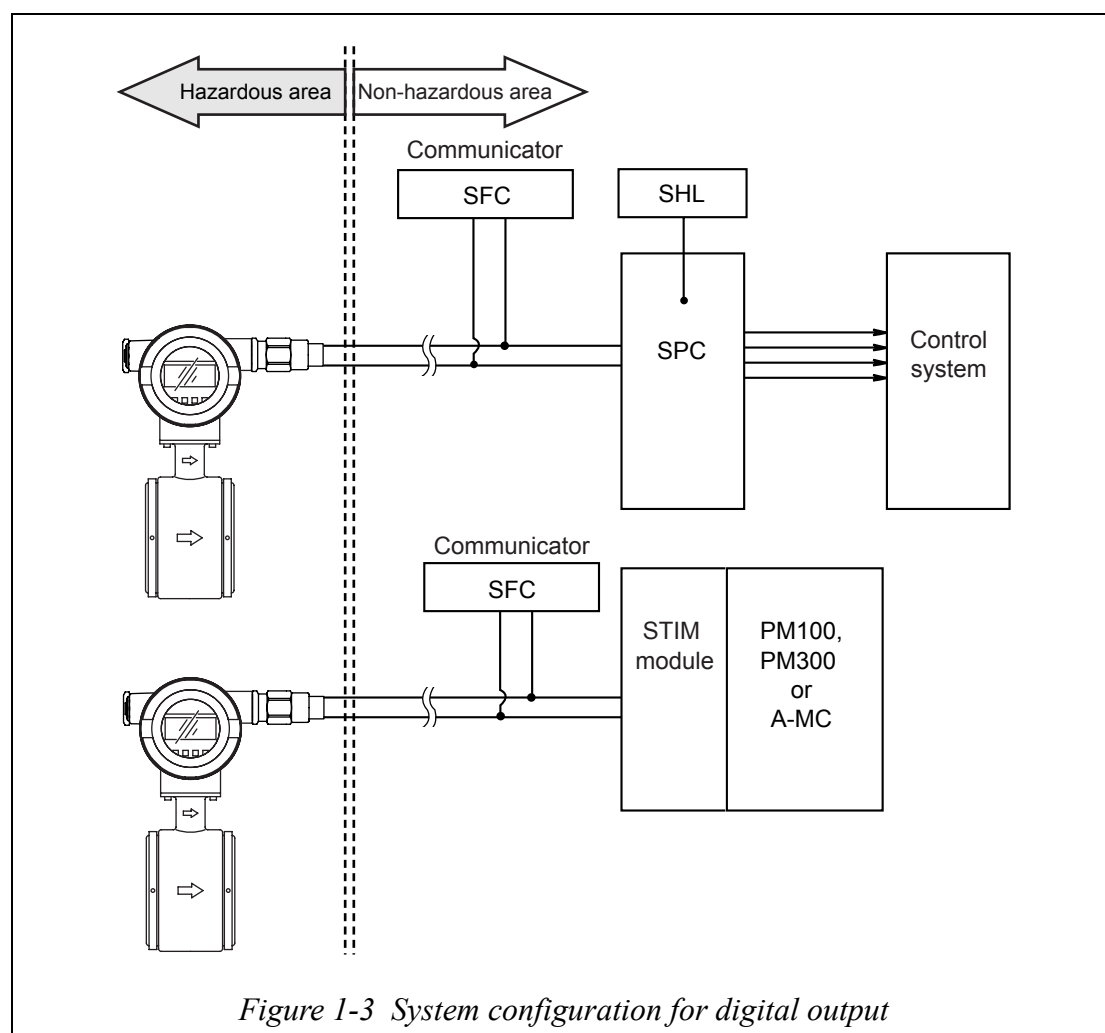

- Smart two-wire electromagnetic flowmeter (main unit): Measures flow rate and outputs the instantaneous flow rate values and the instrument's self-diagnosis results as the form of digital signals.
- Smart protocol converter (SPC): Receives DE protocol based digital signals from this instrument and converts them into a 4-20mA DC or 1-5 V DC analog signal and outputs it.
- Smart handy loader: Used to change SPC settings data.
- Communicator: Used to communicate with this instrument, read data and change the instrument's settings data.
- PM100, PM300, A-MC: These are process controllers on the UCN and do regulatory control, sequences, arithmetic operations, process I/O and other functions simultaneously.

- STIM module: This is an I/O module for smart transmitter interfaces to connect a process manager (PM) to model MTG or other field equipment.

System configuration for pulse output

System configuration

An example of system configuration is shown. Instantaneous flow rate values measured by this instrument are outputted as a pulse output with the specified pulse width and pulse weight.

Besides an analog signal, this system configuration allows the instrument to output a pulse output to an electronic counter, sequencer or other host control system or counter.

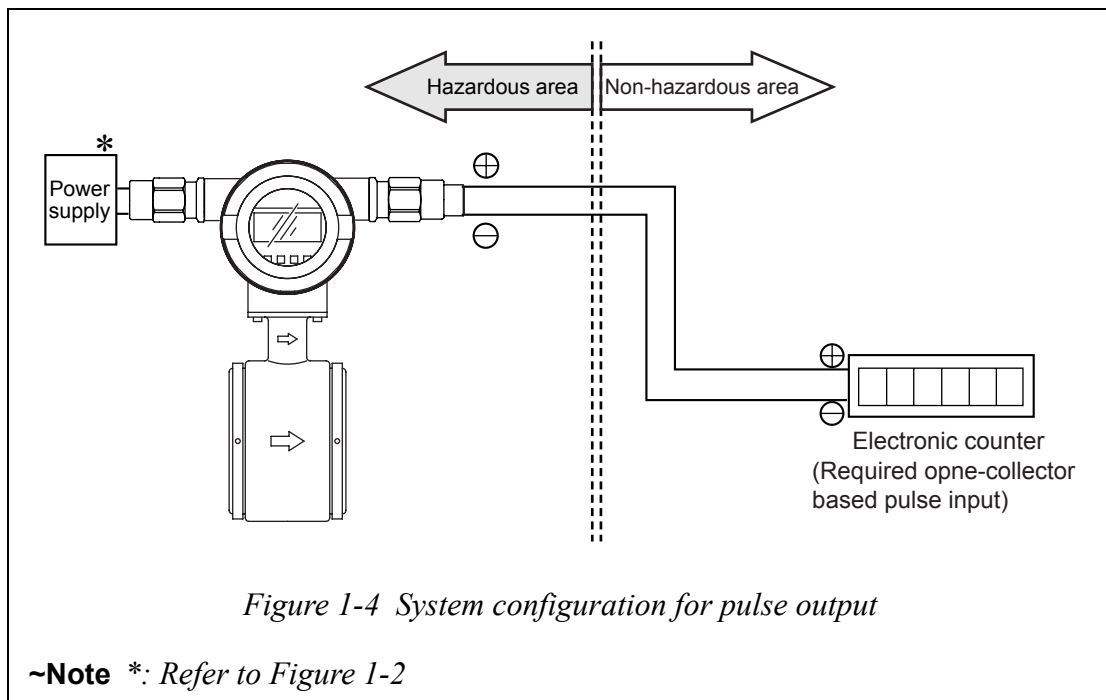

- Smart two-wire electromagnetic flowmeter (main unit): Measures flow rate and outputs a pulse output signal to an electronic counter. Displays the measured flow rate as a flow rate value.
- Electronic counter: Receives the pulse input signal as input and displays the integrated value and control the target equipment by batch control function.
- Open collector: A pulse output method using a transistor contact.

System configuration for contact output

System configuration

An example of system configuration is shown. If the instantaneous flow rate value measured by this instrument reaches to the upper or lower limit settings or a major failure occurs in the instrument, that state is outputted as a contact output.

In this system configuration, it is not only an analog signal but also the instrument to output the contact output to a sequencer or other host control system.

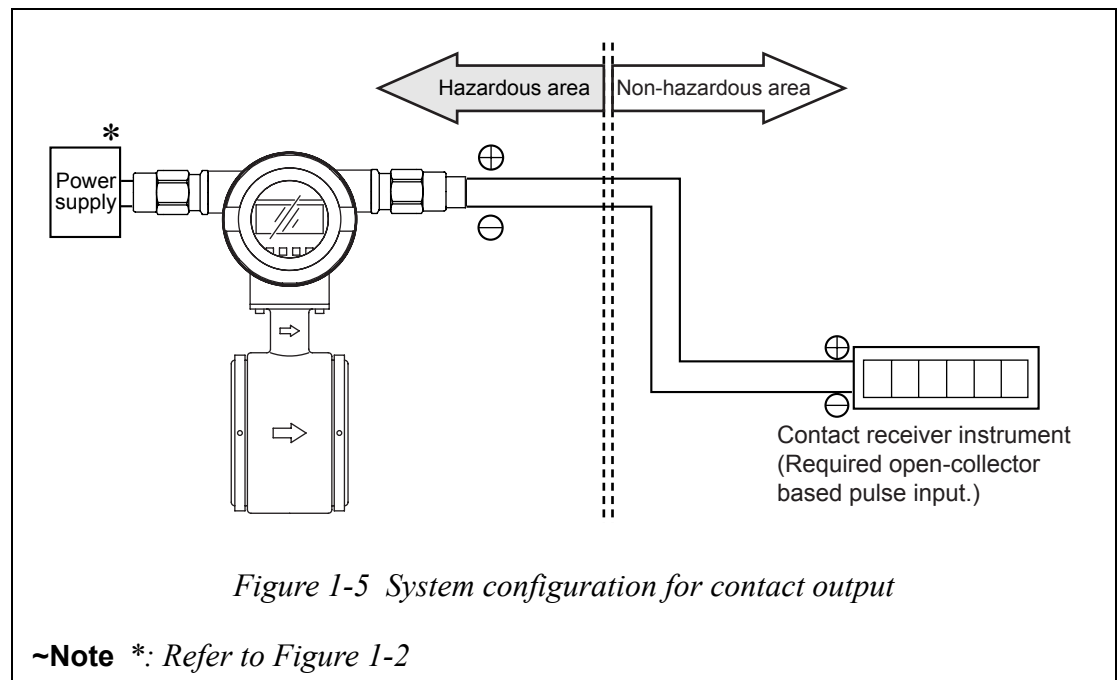

- Smart two-wire electromagnetic flowmeter (main unit): Measures flow rate and outputs an upper or lower limit alarm or major failure as a contact output.
- Contact receive instrument: Receive the contact input.
- Open collector: An output method using a transistor contact.

1-2 : JIS Explosion-protected apparatus

Before use

This is flameproof structure flowmeter. Read this item carefully to ensure correct use.

Flameproof structure

Flameproof structure means a totally enclosed housing that is capable of withstanding an explosion of a gas or vapor within it, and of preventing the ignition of an explosive gas or vapor that may surround it.

CAUTION

Before opening cover, you must turn off the power and wait for seven (7) minutes.

Location guidelines

Install the flowmeter in accordance with the following guidelines:

- The flowmeter can be installed in hazardous areas of grade:

$$\frac{\text{IIC}}{1} \quad \frac{\text{T4}}{2}$$

- Explosive gaseous atmosphere graded IIC
- Gaseous atmosphere where the ignition temperature is 135°C or greater

This means that the flowmeter can only be installed in Class I and II locations. It cannot be installed in Class 0 locations.

- When installing the flowmeter in a hazardous or non-hazardous area, refer to the installation specifications described in the appendix for the correct wiring.
- The pressure-resistant packing cable adapter must be placed in the signal wire outlet of the flowmeter converter. Use the adapter supplied.
- Handle the flowmeter case and cover carefully to prevent any damage or distortion. Properly tighten the converter cover and never open it during operation.

The specified explosion capability cannot be guaranteed if any of the above guidelines are ignored.

When wiring the flowmeter in a Class 1 Hazardous Area, or in any area where only low voltage wiring work is allowed, follow procedures published by the Technology Institution of Industrial Safety.

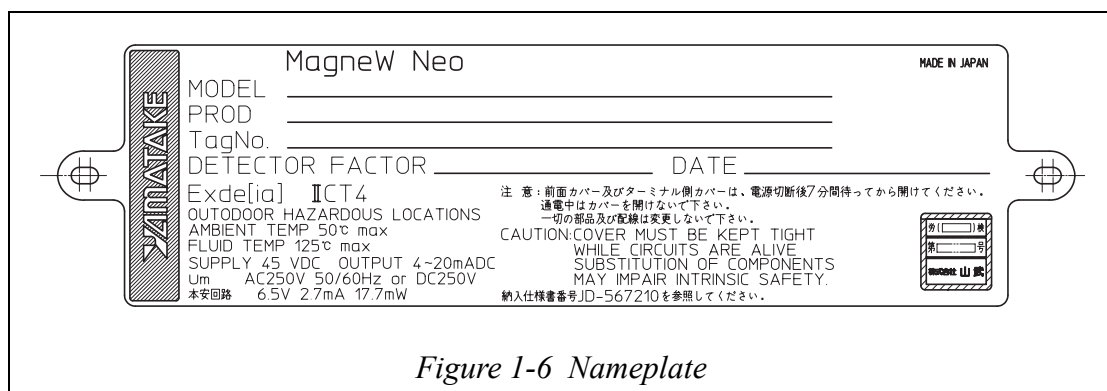

Figure 1-6 Nameplate

1-3 : Structure of this instrument and functions of its various parts

Structure of main unit

Major components

This instrument consists of a detector and converter. The converter, consists of the converter proper, indicator/data setter and terminal box. Figure 1-7 shows overview of the instrument. (The detail specification and outline drawing, refer to SS2-MTG100-0100)

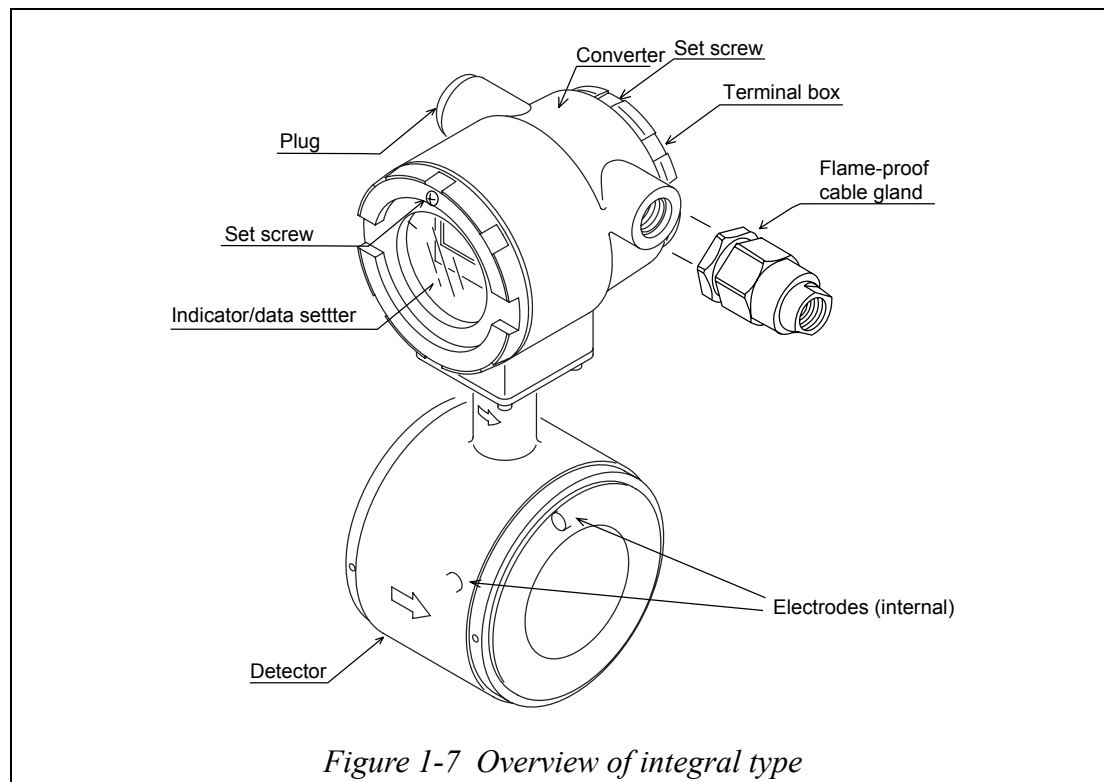

Names and description of various parts

The following table gives a description of the various parts.

Name	Description
Detector	<ul style="list-style-type: none"> When a fluid passes through the inside, the detector generates a signal of electromotive force that is proportional to the passing flow rate. Connects to the pipes and supports the entire instrument. As to the electrode position, both electrodes are installed in a horizontal position.
Converter	<ul style="list-style-type: none"> Transmits the signal of electromotive force generated by the detector into an instantaneous flow rate value and outputs it as a flow rate signal.
Indicator/data setter	<ul style="list-style-type: none"> Displays the instantaneous flow rate value and internal conditions of the instrument.
Terminal box	Contains output signal and grounding terminals.
Nameplate	MODEL No., PRODUCT No. and detector constant (EX) are written.
TAG No. plate	TAG No. is stamped according to the order specification.
Set screw	Keep the cover tightened and ensure the flame-proof capability. Use the device with set screw tightened.
Flame-proof cable gland	Seal the cable to assure the flame-proof capability. Required for explosion-proof instrumentation.

Detector 1: Flanged type

Description

The flanged detector has the function and structure as follows:

- When a fluid passes through the inside, the detector generates a signal of electromotive force, which is proportional to the passing flow rate.
- Installs to the pipes and supports the entire instrument.
- As to the electrode position, both electrodes are installed in a horizontal position.

Names of various parts

The structure and names of various parts of the detector are shown.

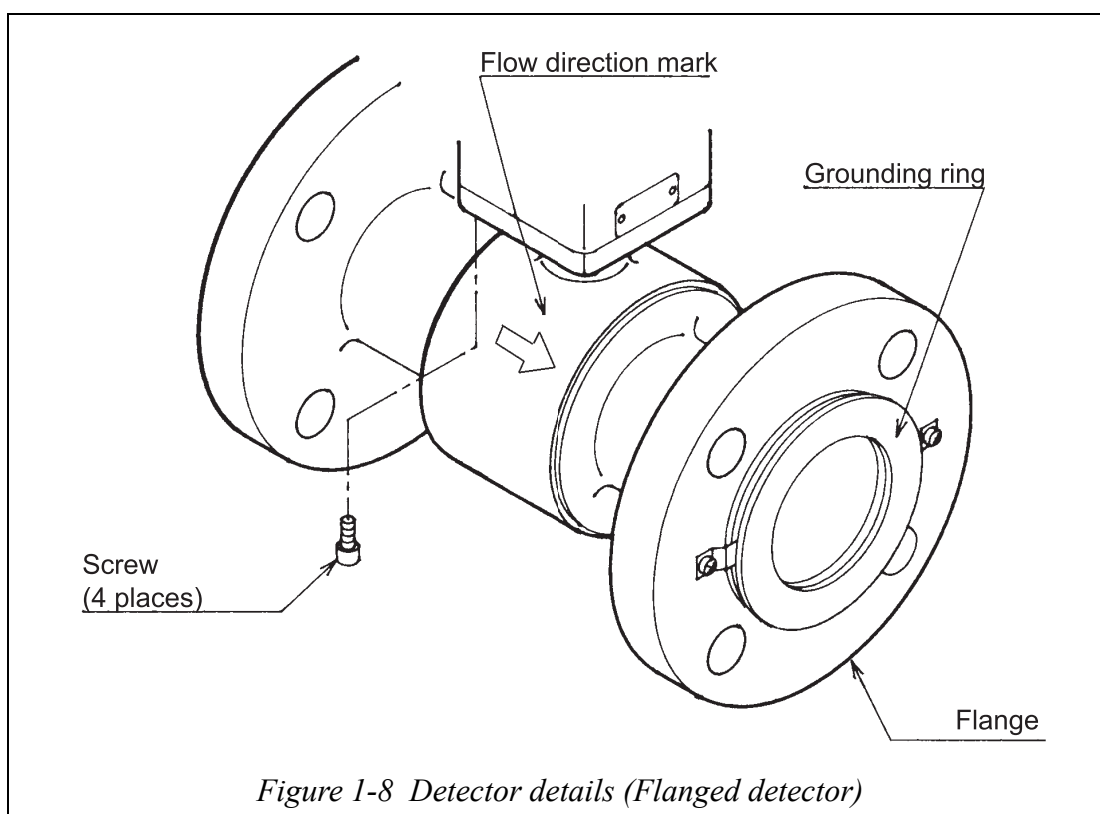

Names and functions of various parts

The following table describes the various parts of the detector.

Name	Description
Flow direction mark	<ul style="list-style-type: none"> • Indicates the flow direction of the fluid. • Mount the detector so that the measured fluid flows in the direction indicated by this mark.
Grounding ring	<ul style="list-style-type: none"> • Keep reference voltage as zero by grounding the unit. The grounding ring material varies depending on the corrosion characteristics of the measured fluid.
Screw	<ul style="list-style-type: none"> • Fixes the detector to the converter. • When these screws are removed, the detector direction may be changed with respect to the converter direction.
Flange	The flanges depend on the flanges on the pipes to which to connect.

Detector 2: Wafer type

Description

The wafer type detector has a function and structure as follows:

- When a fluid passes through the inside, the detector generates a signal of electromotive force that is proportional to the passing flow rate.
- As to the electrode position, both electrodes are installed in a horizontal position.

Names of various parts

The structure and names of various parts of the detector are shown.

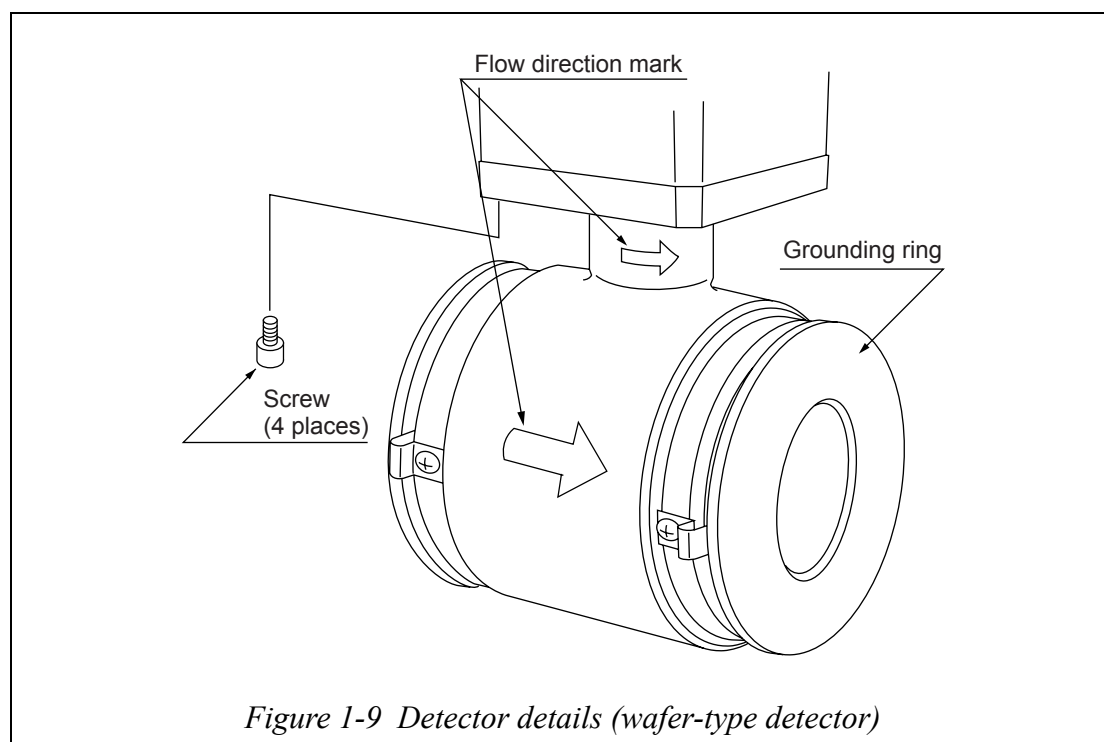

Names and functions of various parts

The following table describes the various parts of the detector.

Name	Description
Flow direction mark	<ul style="list-style-type: none"> • Indicates the flow direction of the fluid. • Mount the detector so that the measured fluid flows in the direction indicated by this mark.
Grounding ring	<ul style="list-style-type: none"> • Keep reference voltage as zero by grounding the unit. The grounding ring material varies depending on the corrosion characteristics of the measured fluid.

Indicator / data setter

Description

The indicator/data setter has the following function and structure.

- Displays the instantaneous flow rate value and internal conditions of the instrument.
- The indicator face can be turned at intervals of 90 degrees through one turn.

Names of various parts

The names of various parts of the indicator/data setter are shown.

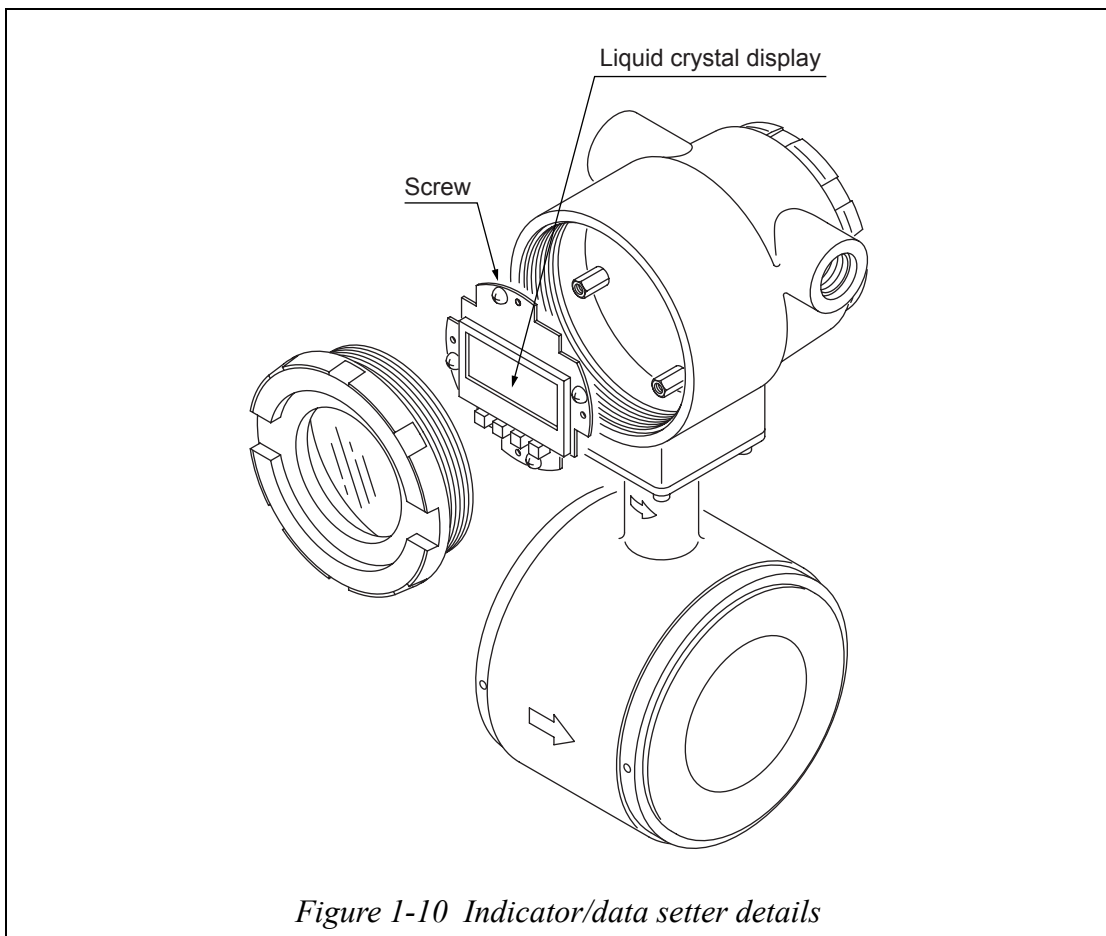

Figure 1-10 Indicator/data setter details

Terminal box

Description

The terminal box contains output signal terminals.

Names of various parts

Figure 1-10 shows the structure and names of various parts of the terminal box.

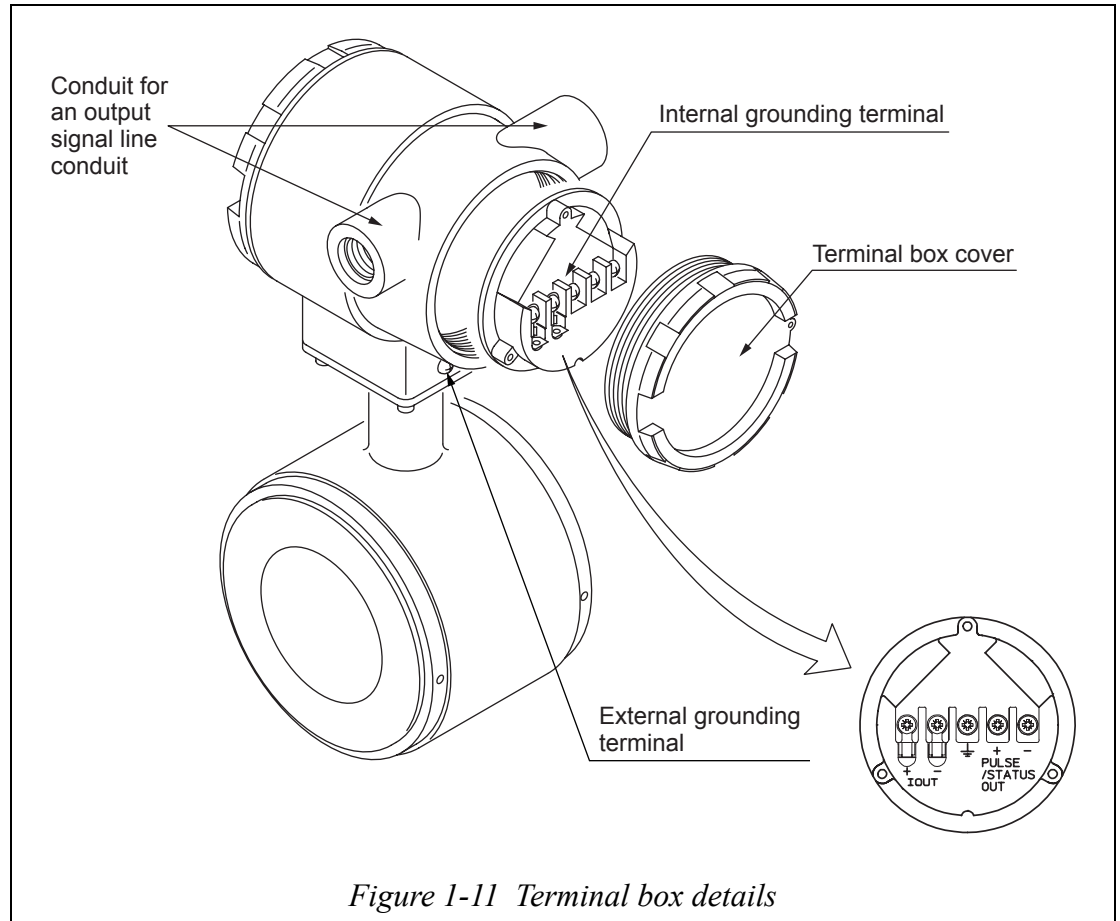
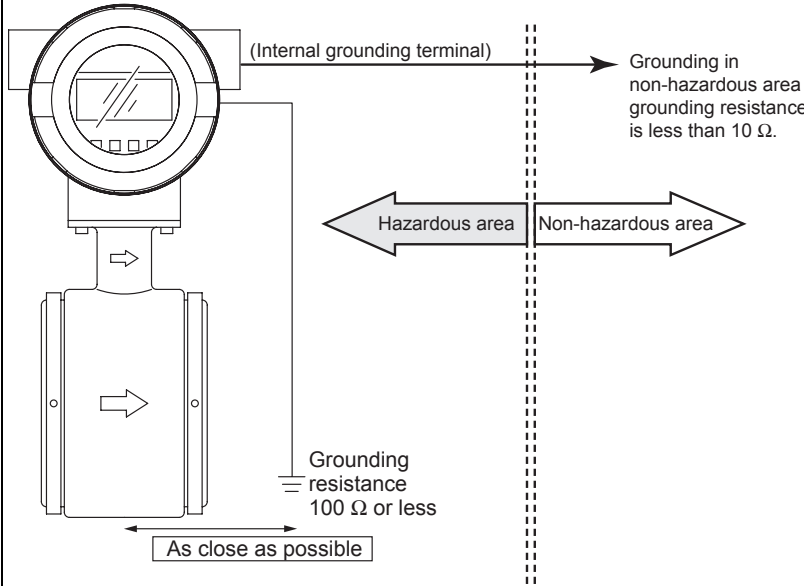

Figure 1-11 Terminal box details

Names and description of various parts

The following table describes the various parts of the terminal box.

Name	Description
Terminal box cover	<ul style="list-style-type: none"> • Watertight construction (equivalent to NEMA 4X)
Wiring precautions	<ul style="list-style-type: none"> • Matters to pay attention to when doing wiring work of this instrument are given.
Output signal terminal	<ul style="list-style-type: none"> • I.OUT+, - : Analog current output and DC power supply terminals • PULSE/STATUS OUT+, - : Open-collector pulse output and contact output terminals
External grounding terminal	<ul style="list-style-type: none"> • Make a grounding at a place as close to this instrument as possible. • The grounding resistance should be 100 Ω or less. If not grounded, malfunction can result. • Internal grounding terminal must be grounded in non-hazardous area with grounding resistance 10 Ω or less.  <p style="text-align: center;"><i>Figure 1-12</i></p>
Internal grounding terminal	<ul style="list-style-type: none"> • If susceptible to noise (while communication takes place), connect one end of the shielded wire to this terminal (which is not used in ordinary cases). • Connected inside to the external grounding terminal. <p>When using, take care not to make a two-point grounding.</p>
Socket for an output signal line conduit	<ul style="list-style-type: none"> • Wire the signal line through this port. • Comes with a plastic dust cover if a type number without a waterproof gland is selected. However, it has no waterproof capability. The customer should provide a waterproof gland.

Chapter 2 : Installing the model MTG

Outline of this chapter

This chapter describes the installation and wiring of the instrument.

The necessary components and installing methods depend on the grounding ring material and installed pipe material.

The description proceeds in the following order:

- Criteria for selecting an installed environment
- Outline of installing method of the instrument
- Material wise detailed installing methods

2-1 : Before installation

Criteria (1) for installation location

Introduction

To bring out the performance of this instrument to the maximum, choose the optimum installation location according to the following criteria for installation location.

Cautions on surrounding environment

- Install at a place where the ambient temperature is in the range from -4°F to +140°F (-20°C to +60°C) and ambient humidity in the range from 10 to 90% RH. Otherwise, instrument failure or output errors may result.
- Avoid a place close to a large-current cable, motor or transformer that may bring about inductive interferences. Otherwise, instrument failure or output errors may result.
- Avoid a place where there are severe vibrations or a highly corrosive atmosphere. Otherwise, a broken detector or damaged instrument may result.
- Avoid a place exposed to direct sunlight if possible. Otherwise, output errors may result.

Cautions on measured fluid

As to the measured fluid, install the instrument where it satisfies the following conditions. Otherwise, output errors or fluctuations may result.

- A place where the measured fluid has an electric conductivity (the value depending on the converter used in combination) required for measurement and the conductivity distribution can be deemed almost even.
- A place where the measured fluid can be deemed electrochemically homogeneous. If, for example, fluids are mixed upstream of the pipe, a place where the two fluids can be deemed to have mixed together homogeneously.
- If an ingredient is mixed in, a place where the ingredient distribution can be deemed to be homogeneous.
- For the following fluids, do not use this instrument even if the electric conductivity, temperature, pressure and others are within the instrument specifications (see Appendix) because they can cause problems in measurement.
 - (1) Fluids that have sufficient conductivity at high temperatures, but do not satisfy the conductivity requirement at room temperature (about 68°F (20°C)). (For example, fatty acids and soap)
 - (2) Some fluids with a surfactant mixed in
(For example, rinse, shampoo and CWM)
 - (3) Insulating adhesive materials
(For example, oil, kaolinite, kaolin, calcium stearate)
 - (4) Slurry fluids containing solid matter
(For example, pulp slurry, mud slurry, cement slurry)

Cautions after installation**CAUTION**

-
- (1) Avoid using this instrument as a foothold after installation because such a use may cause damage to equipment or humans.
 - (2) The integral type of this instrument uses glass for the converter window. It can break if hit by a hand tool or other kind of utensil, and broken glass pieces may injure you. Pay attention.
-

**WARNING**

-
- (1) When removing this instrument, do removal work after ascertaining that there is no residual liquid or pressure in the pipe or inside the detector. Otherwise, you may be injured.
-
- The output signal or indication may fluctuate depending on pulsation or other conditions of the fluid. In such cases, increase the dumping time constant or take some other measure.

Criteria (2) for installation location

Installed position

Install the instrument at a place where the measured fluid always fills inside the detector. An example of installation is shown in the figure below to illustrate this condition.

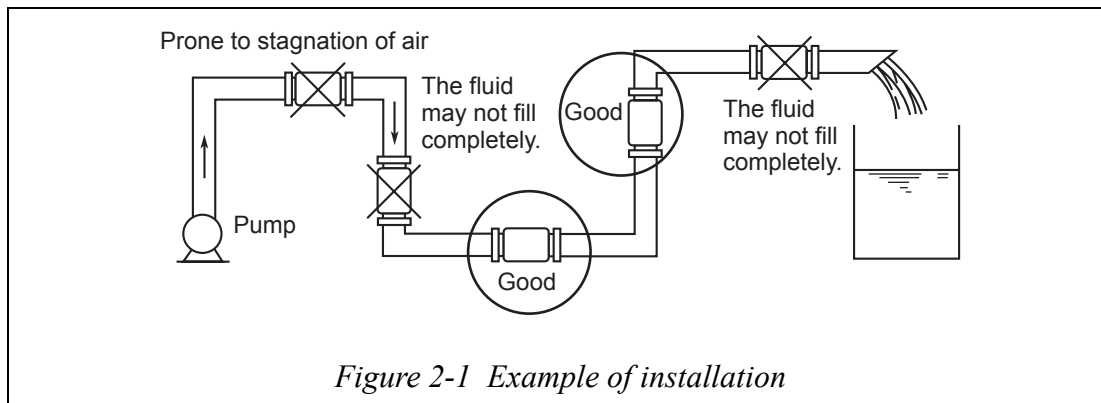

- ~Note**
- Install the instrument under the condition marked by a circle in the figure above with the detector filled with the fluid in full. If the detector is not filled in full, output errors may result. If empty, output fluctuations may result.
 - If the measured fluid is highly viscous, we recommend installing the instrument on a vertical pipe and flowing the fluid to ensure an axially symmetrical flow.
 - Arrange a straight pipe section upstream and downstream of the installed place. For the straight section length, see the figure below.

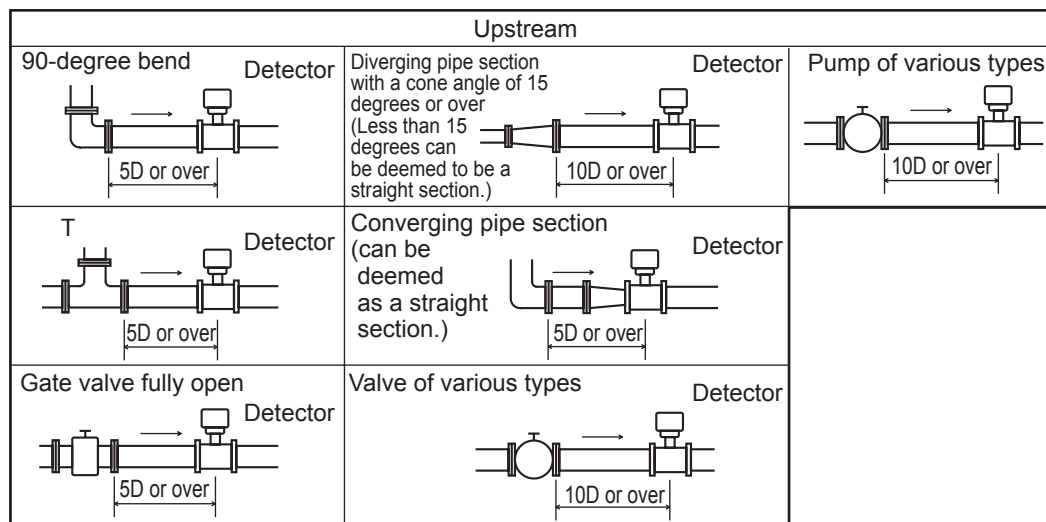

Figure 2-2 Straight pipe section upstream of detector (D: Nominal detector bore diameter)

- No straight pipe section is basically needed on the downstream side. However, ensure 2D or over if influences of drift are foreseen.
- Choose a place where there are little pulsations in the flow (install at a place sufficiently distant from a pump or the like).
- Ensure a space necessary to maintain the terminal box.

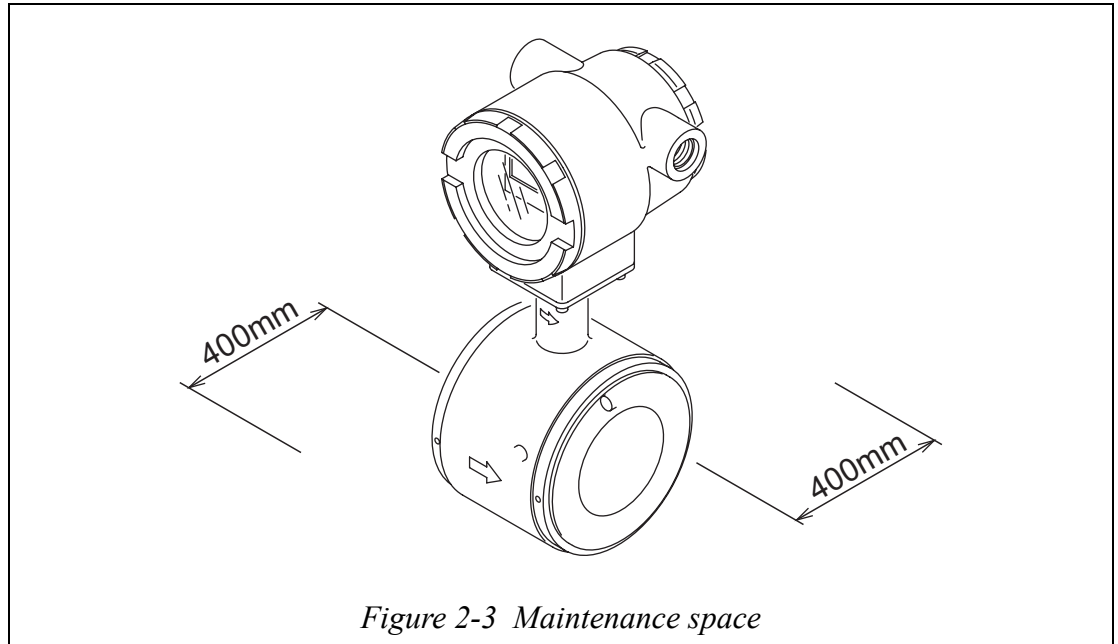

Figure 2-3 Maintenance space

Direction of display/data setter

Changing the display / data setter direction

The display / data setter can be changed to a horizontal or vertical direction.

Step	Procedure
1	Power-off the converter. For the power-off, use the circuit breaker or the like.
2	The converter front cover is fixed by hexagon socket head setscrews (M3). Loosen the setscrews with an Allen wrench (1.5).
3	Remove the converter front cover by turning it counterclockwise with the dedicated tool. ~Note Remove the front cover straight toward you with care.
4	The display / data setter is fixed by three screws. Remove these screws. ~Note The screws are not captive to the display / data setter, so take care not to drop them.
5	Remove the display / data setter. ~Note A cable is attached to the rear side of the display / data setter. This cable is connected to the connector on the converter proper.
6	Turn the display / data setter to the desired direction and align it to the threaded holes in the converter proper.
7	Fix the display / data setter again using the three screws. When tightening the screws, take care not to entangle the cable.
8	Attach the front cover. ~Note Take care not injure your fingers by the cover edge or the thread in the case.

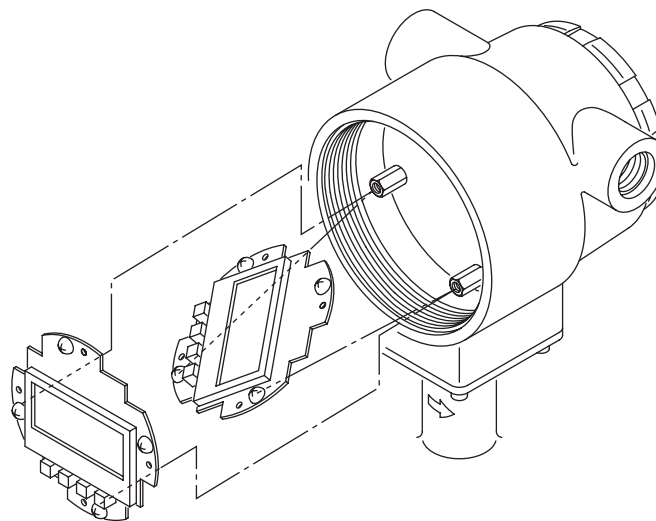

Figure 2-4 Changing the display / data setter direction

2-2 : Method of Installation

2-2-1 : Installing a safer type detector

Basic installation method

Introduction

Process connection of the instrument are wafer type, flange type, union, hose, or clamp unit. Referring to the appropriate method of installation, install the unit properly.

Installation example

Figure 2-5 shows the basic method for installing the device.

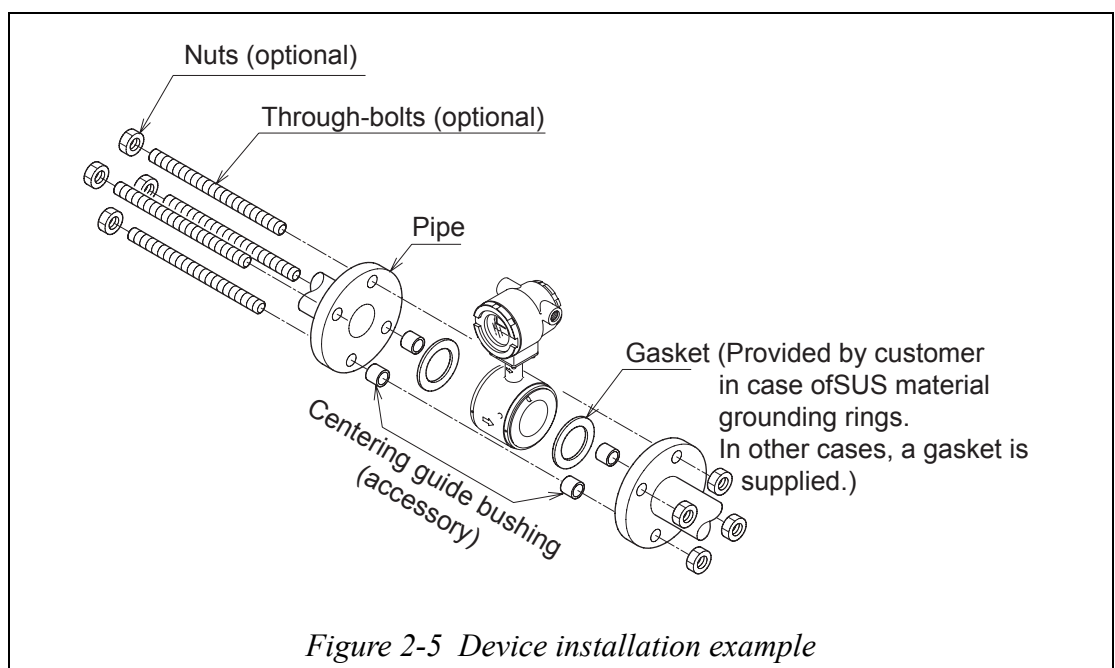

CAUTION

Be careful in handling this unit. It is heavy, dropping it accidentally could cause injury.

Fastening torque

CAUTION

Table 2-1 shows the fastening torque for each pipe bore. Using centering hardware, apply the prescribed fastening torque to prevent any liquid leak from the pipe.

Table 2-1 Fastening torque levels

Nominal detector bore	Fastening torque
25 mm	20 to 30 N•m (14.7 to 22.1 ft•lb)
40 mm, 50 mm, 65 mm, 80 mm	30 to 50 N•m (22.1 to 36.8 ft•lb)
100 mm	50 to 70 N•m (36.8 to 51.6 ft•lb)

Flange shape

The flanges used should be such that the area of contact with the gasket is maximized, as shown in Figure 2-6.

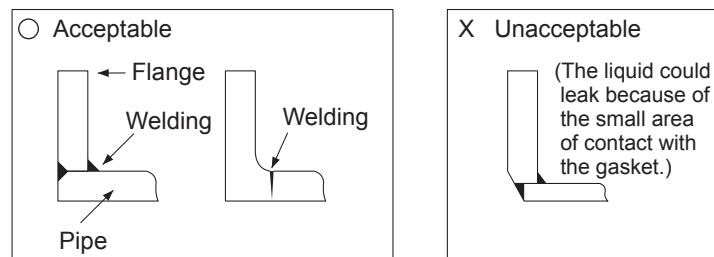
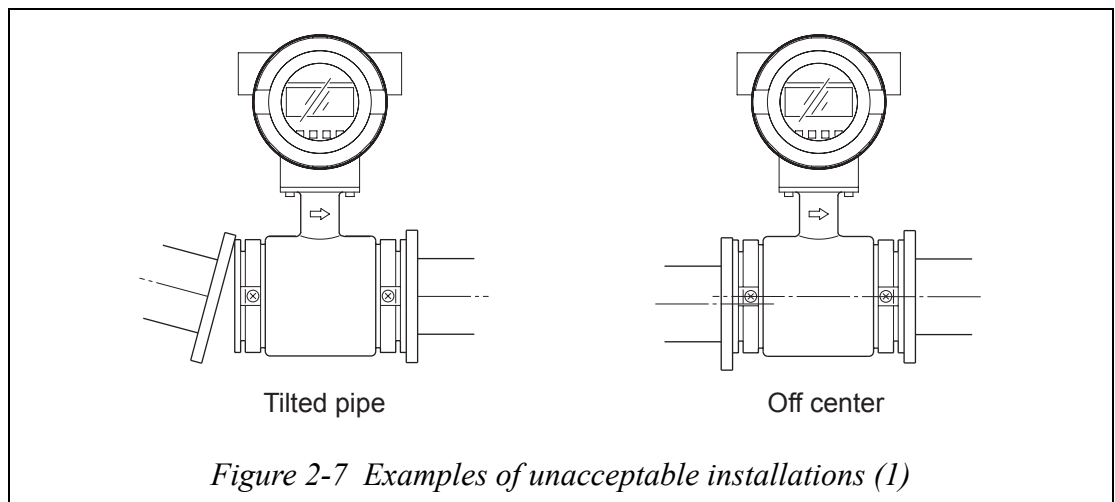

Figure 2-6 Flange shape

- ~Note**
- Before installing the detector be sure to flush out any foreign matter that may be present in inside of the detector. Residual foreign matter could cause output fluctuations.
 - Do not touch the electrodes by your hand or waste cloth with oil. It could cause output fluctuations.
 - Install the detector in accordance with the flow direction mark on the detector with the direction of the liquid flow. Misalignment could result in a negative output.

CAUTION

Before installing the detector make sure that the pipe is exactly straight and centered. Any irregularity in these respects could cause leakage or other hazards.



~Note *Never force the device between two flanges when the space is too narrow. It can damage the detector.*

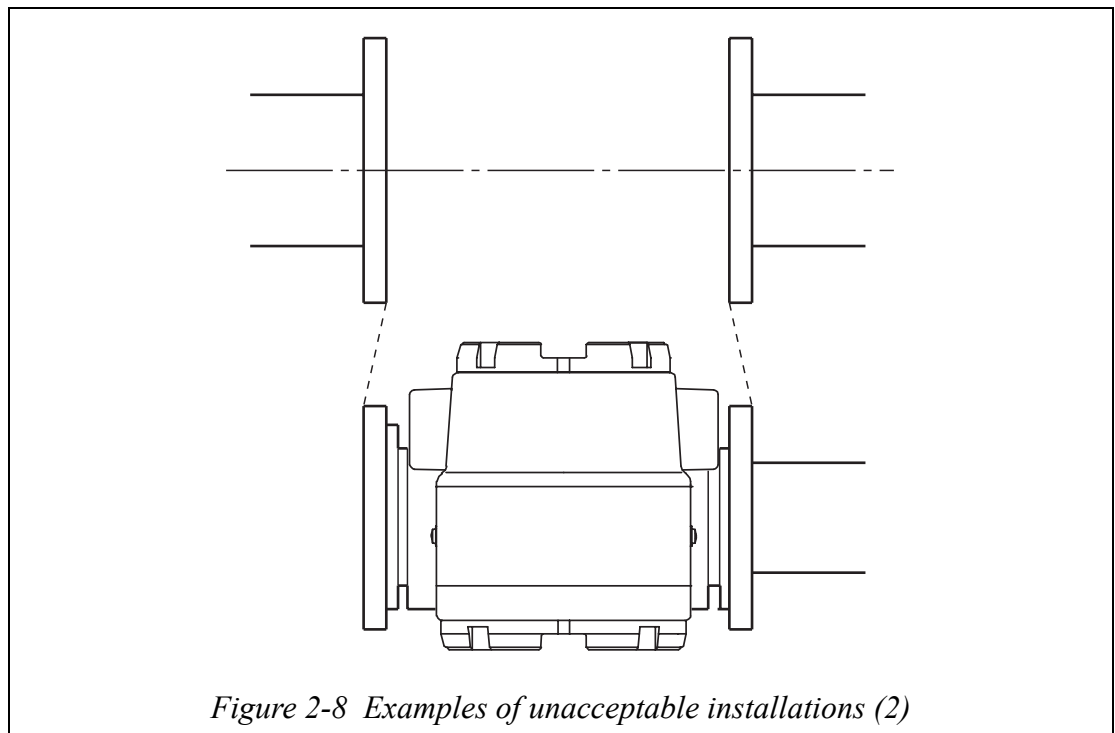

⚠ WARNING

Ensure the bore diameters of the pipe and the detector are exactly the same, install the detector so that the gasket does not protrude into the internal bore of the pipe, as this could result in leakage or other hazards.

~Note *Tighten each bolt a little at a time and apply uniform torque to all the bolts while fastening them. If leakage does not stop on completion of fastening, make sure that the pipe is not off center, then tighten the bolts little by little. Install the detector carefully so that the fastening torque does not exceed the prescribed limit; otherwise the detector could be damaged.*

Accessory parts for installation

Introduction

The following parts are necessary for the installation of the detector:

- Centering guide bushing (standard accessory)
- Through bolts and nuts (option)
- Gaskets: Provide gaskets by customer when using grounding rings made of SUS material.
Supplied gaskets as standard accessory, when using grounding rings made of hastelloy, titanium, tantallum, or platinum.
- Protective plate: Required when connecting the detector to polyvinyl chloride (PVC) piping

Centering guide bushings

To install the detector, use centering bushing to ensure the exact centerize of the pipe and the detector.

Slip the centering bolts onto the through-bolts, and set the detector on top of the nuts so that the nuts are on four sides of the detector.

The positions of the centering bushings depend on the direction in which the detector is installed.

For the positions of the centering bushings, refer to Figure 2-9 and Figure 2-10.

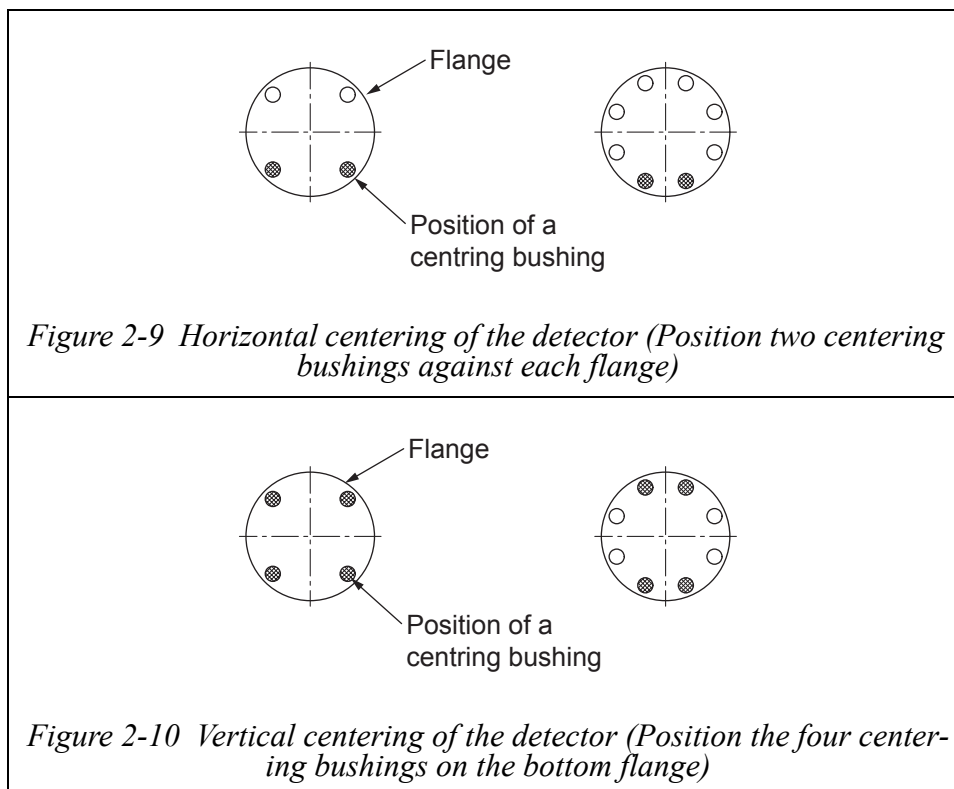

Gaskets

Gaskets are supplied with the grounding ring as standard accessory, except when it is made of SUS material. Secure gaskets when you use a grounding ring made of SUS material. We recommend gasket material such as joint sheet or PTFE. For the internal diameters of the gaskets, refer to Table 2-2. We do not recommend the use of rubber gaskets. Observe the precautions below.

- ~Note**
- *A gasket with too small internal diameter may generate turbulent flow and affect resulting in inaccurate measurements.*
 - *A gasket with too large internal diameter may cause leakage. Also, any solid substance in the fluid to be measured could accumulate between the gasket and the flange, resulting in inaccurate measurements.*

Table 2-2 Recommended internal diameters of gaskets

(Unit: mm)

Body diameter Dimensions	25 mm (1 inch)	40 mm (1½ inch)	50 mm (2 inches)	65 mm (2½ inches)	80 mm (3 inches)	100 mm (4 inches)
Internal diameter	25 ±1	40 ±1	51 ±1	64 ±1	76 ±1	101 ±1

If you install the detector at a lower torque level using rubber gaskets, you must use gaskets with the internal and external diameters shown in Table 2-3 for the respective pipe size. Depending on the grounding ring material, two gaskets of different thicknesses may be required. (See Figure 2-16 on page 2-19 and Figure 2-19 on page 2-21.)

Table 2-3 Internal and external diameters of rubber gaskets (0.5 to 1 mm thick)

(Unit: mm)

Body diameter Dimensions	25 mm (1 inch)	40 mm (1½ inch)	50 mm (2 inches)	65 mm (2½ inches)	80 mm (3 inches)	100 mm (4 inches)
Internal diameter	25 ±1	40 ±1	51 ±1	64 ±1	76 ±1	101 ±1
External diameter	50 ±1	75 ±1	91 ±1	111 ±1	121 ±1	146 ±1

Table 2-4 Internal and external diameter of rubber gaskets (3 to 4 mm thick)

(Unit: mm)

Body diameter Dimensions	25 mm (1 inch)	40 mm (1½ inch)	50 mm (2 inches)	65 mm (2½ inches)	80 mm (3 inches)	100 mm (4 inches)
Internal diameter	25 ±1	39 ±1	51 ±1	64 ±1	76 ±1	101 ±1
External diameter	50 ±1	68 ±1	84 ±1	104 ±1	114 ±1	139 ±1

Selecting an installation method

CAUTION

The necessary materials and the installation method vary according to the material of the ring and that of the pipe on which the detector is to be installed. Select the appropriate method of installation after confirming the specifications of the detector to be installed and the conditions of installation. Improper installation may result in leakage or damage to the pipe flanges.

Installation method according to materials

Select the appropriate installation method from the table below.

Pipe material	Grounding ring material	See page
Metal	SUS material	2-16
	Non-SUS material	2-17
PVC	SUS material	2-18
	Non-SUS material	2-20

Installation on horizontal pipe

CAUTION

Improper installation may result in leakage or damage to the pipe flanges.

Required accessories

The following parts are required:

- Through-bolts and nuts
- Centering guide bushing
- Gaskets: The required gasket material will vary according to the material of the pipe on which the detector is to be installed. See the installation procedures for different pipe materials described on pages 2-16 to 2-21.

Procedure

Follow this procedure to install the detector on a horizontal pipe.

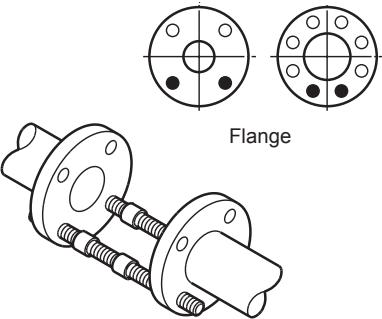
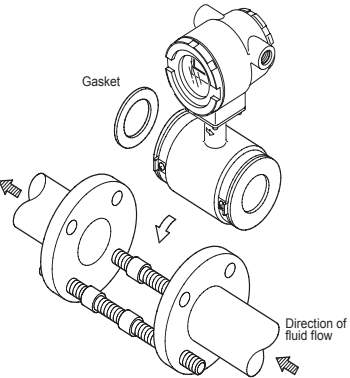
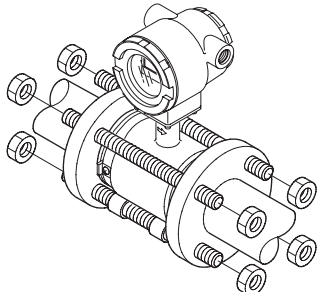
Step	Action	Drawing
1	Insert through-bolts in the flange holes shown by black dots in the drawing. Slip two centering nuts onto each through-bolt before inserting the bolts.	 <p style="text-align: center;">Flange</p>
2	<ul style="list-style-type: none"> • Turn the detector so that the direction mark on the detector matches the direction of fluid flow. • Insert the detector and gaskets between the pipe flanges. • Position the detector so that it sits on top of the centering. 	 <p style="text-align: center;">Gasket</p> <p style="text-align: right;">Direction of fluid flow</p>
3	<ul style="list-style-type: none"> • Make sure that the detector remains properly centered. • Make sure that the gaskets do not protrude beyond the edges of the pipe flanges. • When you have checked these items, insert the remaining through-bolts into the flange holes and tighten the bolts evenly using the appropriate fastening torque given on page 2-7. 	

Installation on vertical pipe

CAUTION

Improper installation may result in leakage or damage to the pipe flanges.

Required accessories

The following parts are required:

- Through-bolts and nuts
- Centering guide bushings
- Gaskets: The required gasket material will vary according to the material of the pipe on which the detector is to be installed. See the installation procedures for different pipe materials described on pages 2-16 to 2-21.

Procedure

Follow this procedure to install the detector on a vertical pipe.

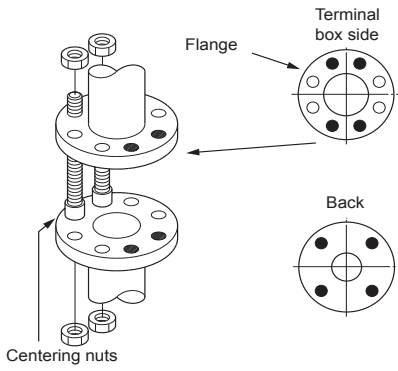
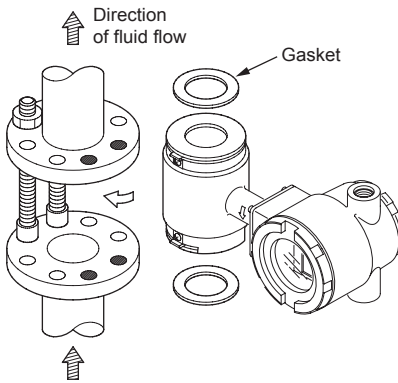
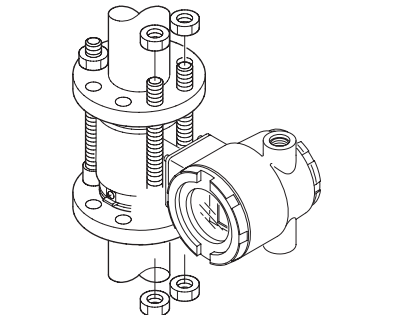
Step	Action	Drawing
1	<ul style="list-style-type: none"> • Of the flange holes shown by black dots in the drawing, insert through-bolts into the two holes at the back and fasten them lightly with nuts. Slip one centering nut onto each through bolt before inserting the bolts. 	
2	<ul style="list-style-type: none"> • Turn the detector so that the direction mark on the detector matches the direction of fluid flow. • Insert the detector and gaskets between the pipe flanges. 	
3	<ul style="list-style-type: none"> • Insert through-bolts fitted with one centering nut each into the remaining two flange holes shown by black dots in steps 1 and 2. 	

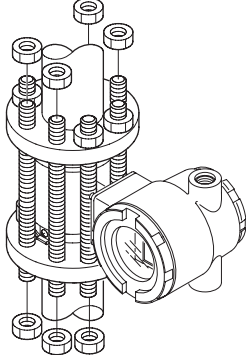
Step	Action	Drawing
4	<ul style="list-style-type: none">• Make sure that the detector remains properly centered.• Make sure that the gaskets do not protrude beyond the edges of the pipe flanges.• When you have checked these items, insert the remaining through-bolts into the flange holes and tighten the bolts evenly using the appropriate fastening torque given on page 2-7.	

Installation on metal pipe (1)

Introduction

The installation method described in this section corresponds to the following combination of pipe and grounding ring materials. For the installation method corresponding to any other combination, refer to the table on page 2-12.

Pipe material: Metal

Grounding ring material: SUS material

Required accessories

The following parts are required:

- Through-bolts and nuts
- Centering guide bushings
- Gaskets: We recommend non-rubber gaskets such as those made of joint sheet or PTE.

For recommended internal diameters, refer to Table 2-2 on page 2-11. Although rubber gaskets may be used, it is not possible to reduce the fastening torque.

Installation procedure

- Install the detector as shown in Figure 2-11. The torque level for tightening the bolts is not related to the gasket material. See Table 2-1 on page 2-8 for the appropriate torque. For the internal diameter of the gaskets, see Table 2-2 on page 2-11.
- To use rubber gaskets for a low fastening torque, refer to page 2-19.

CAUTION

Please note that the use of rubber gaskets and a lower fastening torque may result in insufficient surface pressure between the lining and the grounding ring, resulting in leakage.



Installation on metal pipe (2)

Introduction

The installation method described in this section corresponds to the following combination of pipe and grounding ring materials. For the installation method corresponding to any other combination, refer to the table on page 2-12.

Pipe material: metal

Grounding ring material: other than SUS material

Required accessories

The following parts are required. No gaskets are necessary since PTFE gaskets are provided.

- Through-bolts and nuts
- Centering guide bushings

Installation procedure

- Install the detector as shown in Figure 2-12. See Table 2-1 on page 2-8 for the appropriate fastening torque.
- To use rubber gaskets for a low fastening torque, refer to page 2-21.

CAUTION

Please note that the use of an additional gasket besides the existing PTFE gasket may result in leakage (see Figure 2-13).

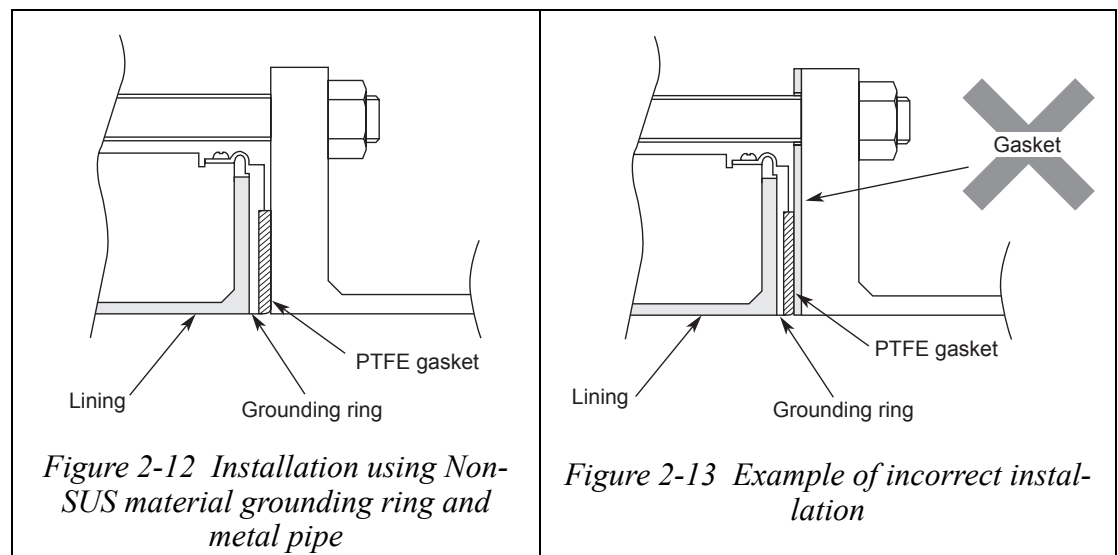

Installation on PVC pipe (1)

Introduction

The installation method described in this section corresponds to the following combination of pipe and grounding ring materials. For the installation method corresponding to any other combination, refer to the table on page 2-12.

Pipe material: PVC

Grounding ring material: SUS material

Required accessories

The following parts are required:

- Through-bolts and nuts
- Centering guide bushings
- Gaskets: Non-rubber gaskets are recommended (i.e. joint sheet or PTFE). See Table 2-2 on page 2-11 for the recommended bore diameters. When using rubber gaskets, another gasket of the same material and with a thickness of 0.5 to 1.0 mm is required. See Table 2-3 on page 2-11 for the appropriated dimensions.
- Protective plate: Use the protective plate if bolt tightening at the specified torque threatens to warp or damage the PVC pipe. See Figure 2-15 for an illustration of the protective plate.

Installation procedure

The installation procedure varies with such conditions as the fastening torque and the need for a protective plate. Choose one of the following three methods as applicable.

1. Use this method to install the detector with a specified fastening torque.
Install the detector as shown in Figure 2-14.
The torque level for tightening the bolts is not related to the gasket material. See Table 2-1 on page 2-8 for the appropriate torque. For the internal diameter of the gaskets, see Table 2-2 on page 2-11.

CAUTION

Please note that the use of rubber gaskets and a lower fastening torque may result in insufficient surface pressure between the lining and the grounding ring, resulting in leakage.

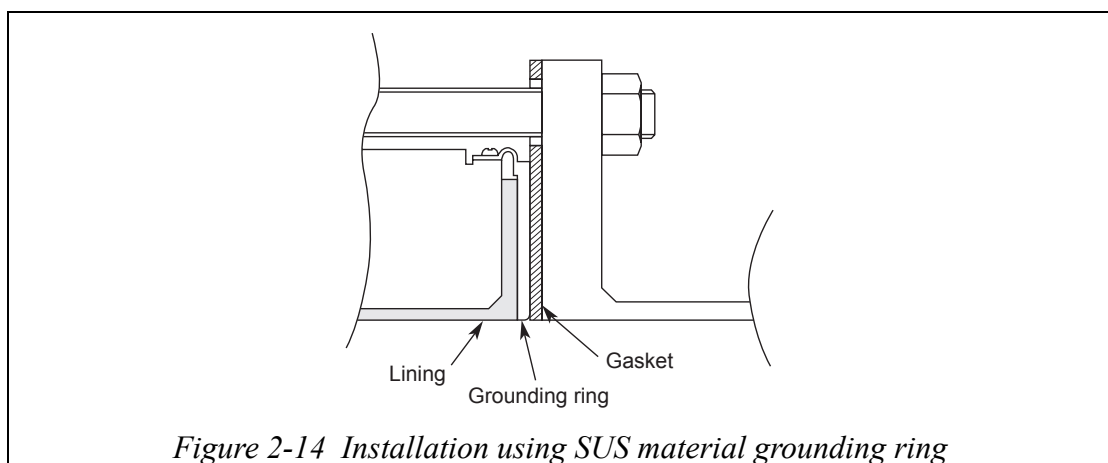

2. Use this method to install the detector using a protective plate to prevent the PVC pipe from being deformed or damaged when the bolts are tightened with the specified torque.

Install the protective plate between the outer side of the PVC flange and the detector, as shown in Figure 2-15. The protective plate protects the PVC pipe from deformation or damage when secured at the specified torque. The torque level is unrelated to the pipe or grounding ring material. See Table 2-1 on page 2-8 for the appropriate torque.

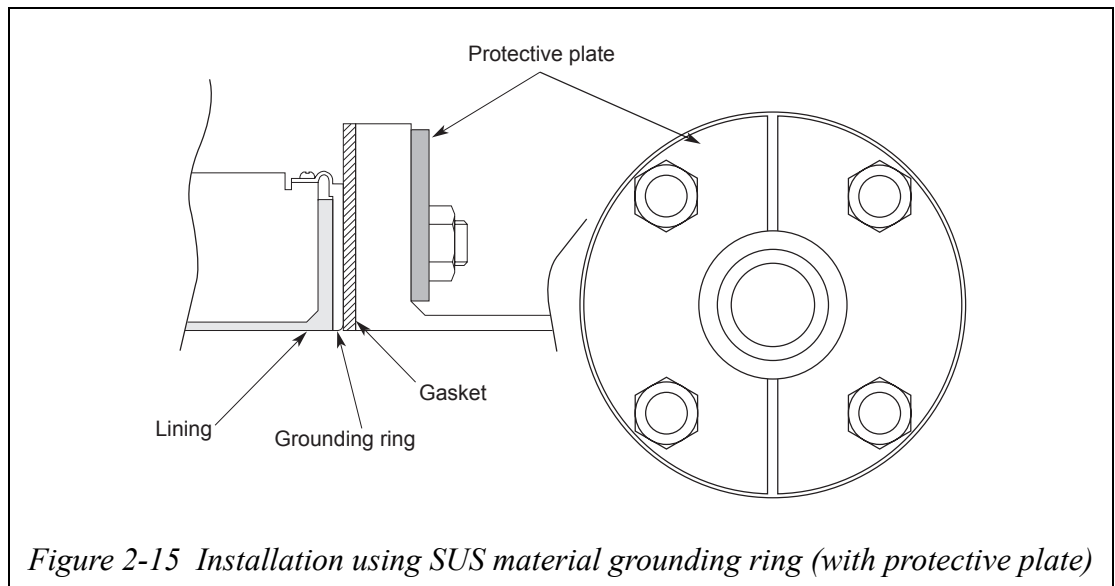

3. Use this method to install the detector using a low fastening torque and rubber gaskets.

Remove the grounding ring from the detector, insert a rubber gasket 0.5 to 1.0 mm thick, then reinsert the grounding ring on top of the rubber gasket. With the rubber gasket in the position shown in Figure 2-16, attach the detector to the pipe. Fasten the bolts with a torque that provides a leakproof joint. In this case, use the two kinds of rubber gaskets made of the same material.

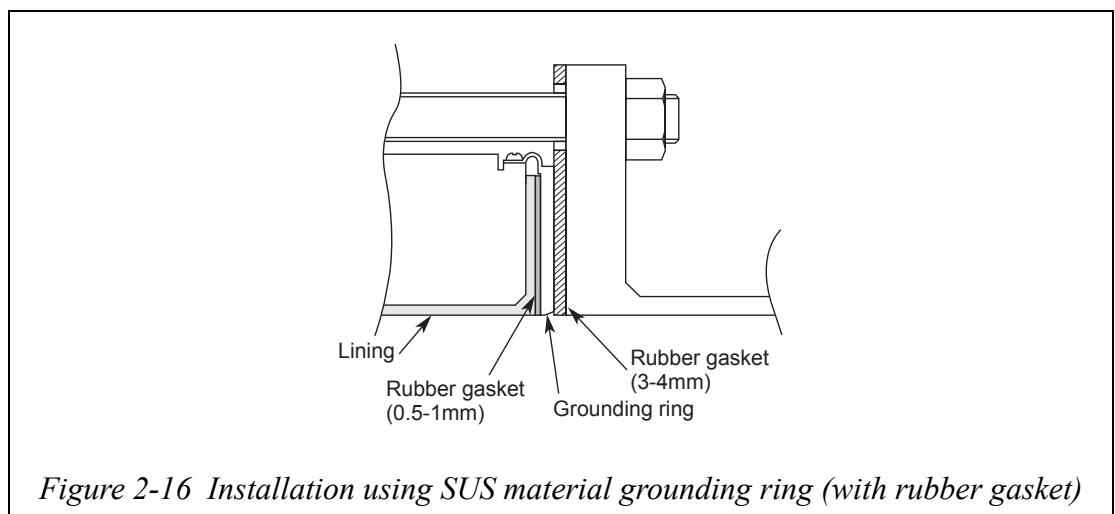

Installation on PVC pipe (2)

Introduction

The installation method described in this section corresponds to the following combination of pipe and grounding ring materials. For the installation method corresponding to any other combination, refer to the table on page 2-12.

Pipe material: PVC

Grounding ring material: Other than SUS material

Required accessories

The following parts are required:

- Through-bolts and nuts
- Centering guide bushings
- Gaskets: No gaskets are necessary due to the provision of a PTFE gasket. When using a rubber gasket, gaskets of the same material and of two thicknesses, 0.5 to 1.0 mm and 3.0 to 4.0 mm, are required. See Table 2-3 and 2-4 on page 2-11 for the appropriate dimensions.
- Protective plate: A protective plate is required if tightening the bolts to the specified torque may deform or damage the PVC pipe. Use stainless steel or similar hard metal 1 mm thick or over. For the shape, see Figure 2-18.

Installation procedure

The installation procedure varies with such conditions as the fastening torque and the need for a protective plate. Choose one of the following three methods as applicable.

1. Use this method to install the detector with the specified fastening torque. Install the detector as shown in Figure 2-17. See Table 2-1 on page 2-8 for the appropriate fastening torque.

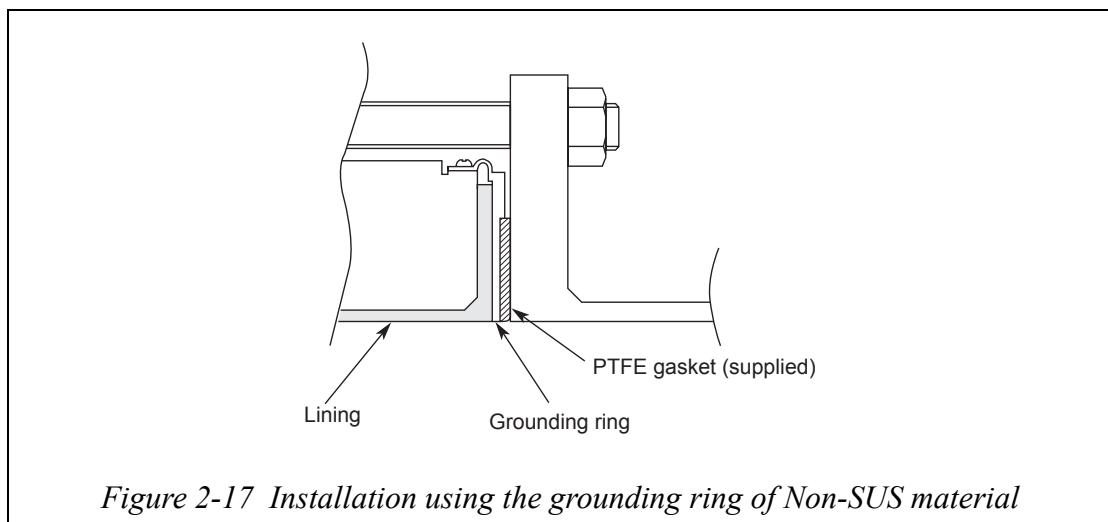

- Use this method to install the detector along with a protective plate to prevent PVC pipe from being deformed or damaged when the bolts are tightened to the specified torque.

Insert a protective plate between the outer side of the PVC flange and the detector as shown in Figure 2-18. The protective plate protects the PVC pipe from deformation or damage when it is secured to the specified torque. For the appropriate torque, see Table 2-1 on page 2-8.

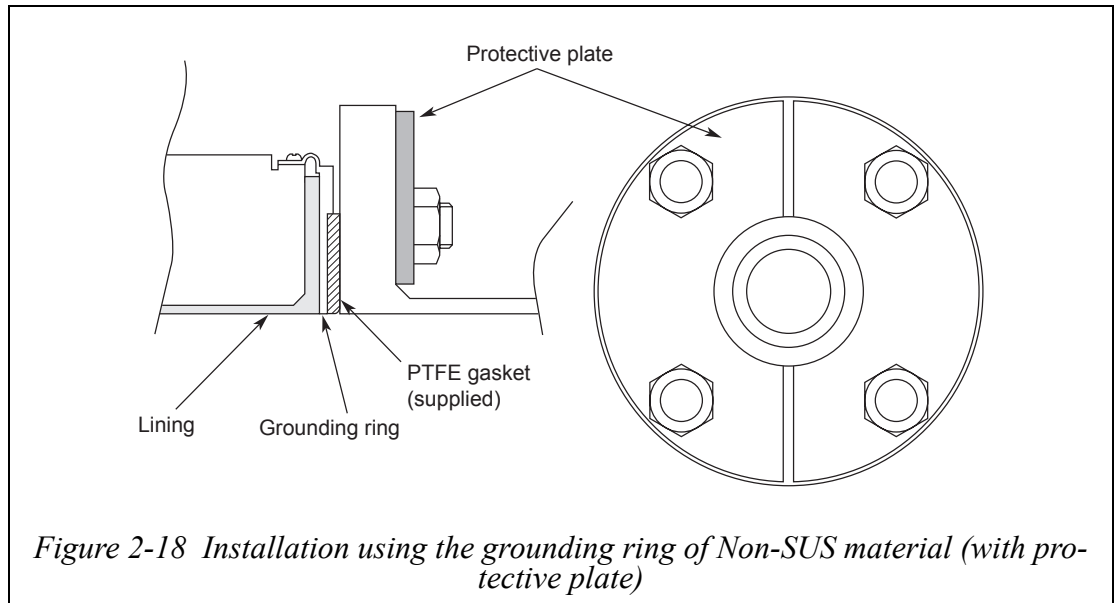

- Use this method to install the detector using a low fastening torque and rubber gaskets. First, remove the grounding ring from the detector, then insert a rubber gasket with a thickness of 0.5 to 1.0 mm. Then reinsert the grounding ring on top of the rubber gasket. Next, remove the PTFE gasket and insert a rubber gasket 3.0 to 4.0 mm thick to replace it. Under these conditions, install the detector on the pipe as shown in Figure 2-19. Tighten the bolts to the torque required to achieve a fluid seal for the rubber gasket. In this case, the two kinds of rubber gaskets that are used should be made of the same material. For the dimensions of the rubber gaskets, refer to Table 2-3 and Table 2-4 on page 2-11.

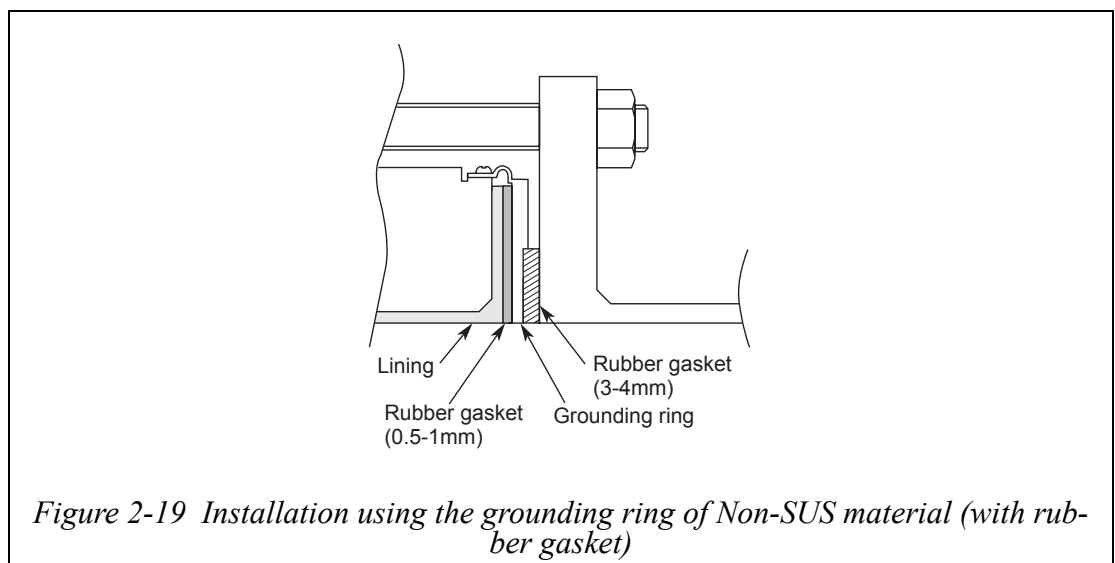

2-2-2 : Installation a flange type detector

Basic installation method

Installation example

Figure 2-20 shows the basic method for installing the device.

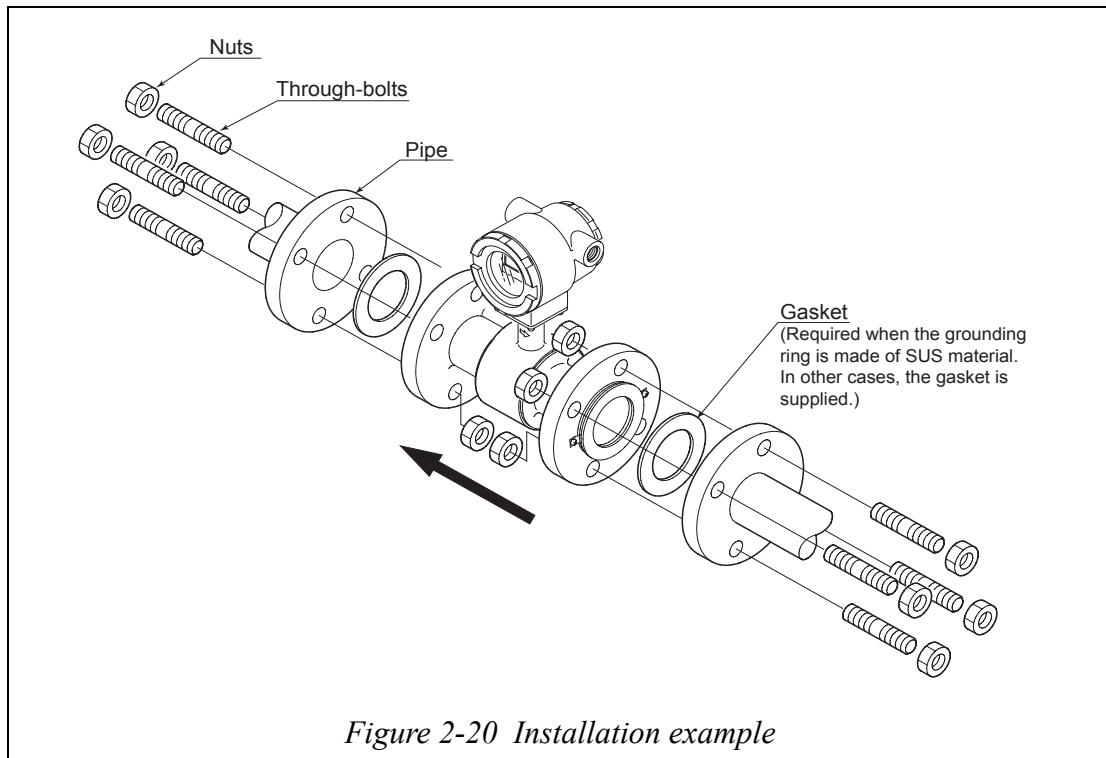

Fastening torque

CAUTION

Be careful in handling flanged detectors. Dropping it could cause injury.

WARNING

Table 2-5 shows the fastening torque for each pipe bore. Apply the prescribed fastening torque to prevent leakage.

Table 2-5 Fastening torque (1)

Diameter and flange ratings		Fastening torque N•m (ft•lb)	
2.5 to 15 mm	JIS 10K	8 to 13	(5.9 to 9.5)
	JIS 20K	8 to 13	(5.9 to 9.5)
	ANSI/JPI 150	9 to 14	(6.6 to 10.3)
	ANSI/JPI 300	10 to 16	(7.3 to 11.8)
25 mm (1 inch)	JIS 10K	21 to 31	(15.4 to 22.8)
	JIS 20K	21 to 32	(15.4 to 23.6)
	ANSI/JPI 150	11 to 17	(8.1 to 12.5)
	ANSI/JPI 300	22 to 34	(16.2 to 25.0)
40 mm (1½ inch)	JIS 10K	22 to 32	(16.2 to 23.6)
	JIS 20K	22 to 34	(16.2 to 25.0)
	ANSI/JPI 150	13 to 18	(9.5 to 13.2)
	ANSI/JPI 300	36 to 57	(26.5 to 42.0)
50 mm (2 inches)	JIS 10K	24 to 34	(17.7 to 25.0)
	JIS 20K	19 to 31	(14.0 to 22.8)
	ANSI/JPI 150	23 to 32	(16.9 to 23.6)
	ANSI/JPI 300	20 to 32	(14.7 to 23.6)
65 mm (2½ inches)	JIS 10K	20 to 31	(14.7 to 22.8)
	JIS 20K	37 to 61	(27.2 to 44.9)
	ANSI/JPI 150	26 to 35	(19.1 to 25.8)
	ANSI/JPI 300	37 to 57	(27.2 to 42.0)
80 mm (3 inches)	JIS 10K	20 to 31	(14.7 to 22.8)
	JIS 20K	37 to 61	(27.2 to 44.9)
	ANSI/JPI 150	26 to 35	(19.1 to 25.8)
	ANSI/JPI 300	37 to 57	(27.2 to 42.0)
100 mm (4 inches)	JIS 10K	22 to 33	(16.2 to 24.3)
	JIS 20K	41 to 66	(30.2 to 48.6)
	ANSI/JPI 150	21 to 31	(15.4 to 22.8)
	ANSI/JPI 300	43 to 66	(31.7 to 48.6)
150 mm (6 inches)	JIS 10K	47 to 67	(34.6 to 49.4)
	JIS 20K	58 to 91	(42.7 to 67.1)
	ANSI/JPI 150	42 to 60	(30.9 to 44.2)
	ANSI/JPI 300	50 to 74	(36.8 to 54.5)
200 mm (8 inches)	JIS 10K	44 to 65	(32.4 to 47.9)
	JIS 20K	66 to 102	(48.6 to 75.2)
	ANSI/JPI 150	42 to 59	(30.9 to 43.5)
	ANSI/JPI 300	81 to 120	(59.7 to 88.5)

Flange shape

Use flanges that will maximize the area of contact with the gasket, as shown in Figure 2-21.

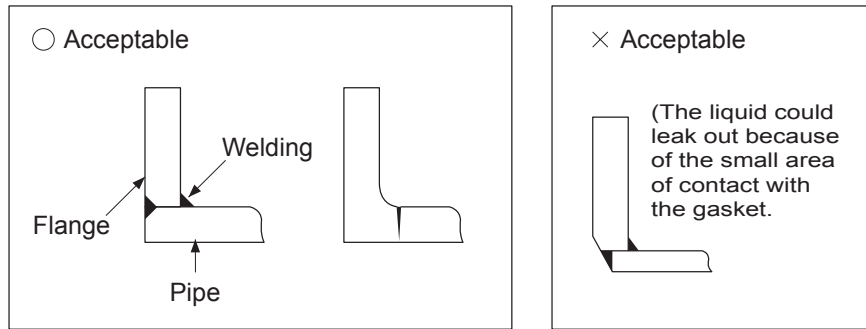

Figure 2-21 Flange shape

~Note

- Before installing the detector, make sure any foreign matter is flushed from the inside of the detector. Residual foreign matter could cause output fluctuations.
- Do not touch the electrodes by your hand or wasted cloth with oil. This could cause output fluctuations.
- Install the detector in accordance with the flow direction mark on the detector in the direction of the liquid flow. Misalignment could result in a negative output.



CAUTION

Never force the detector between two flanges when the space is too narrow. It can damage the detector.

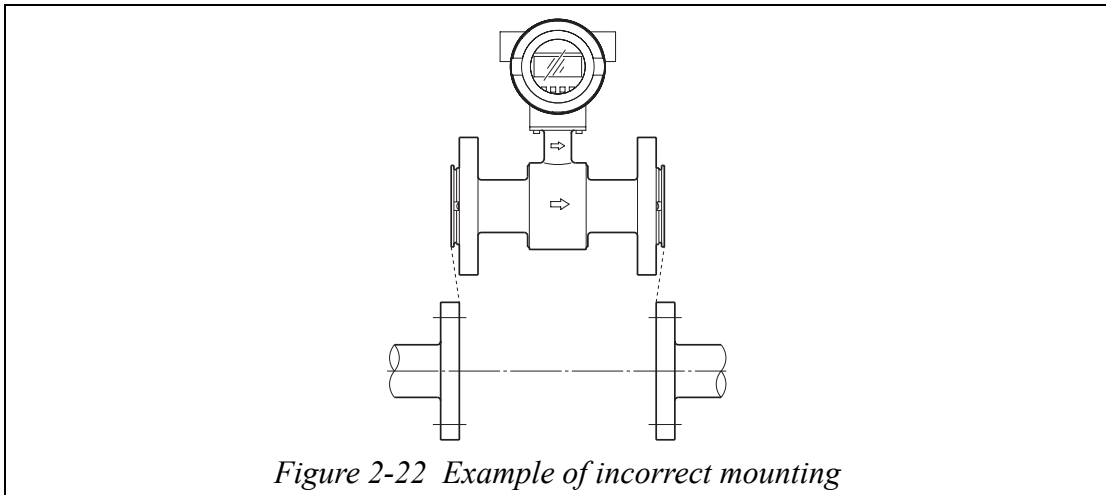

Figure 2-22 Example of incorrect mounting



WARNING

After ensuring that the internal diameter of the pipe and that of the detector are the exactly the same, install the detector so that the gasket does not protrude into the internal diameter of the pipe. Failing to do so could result in leakage or other hazards.

~Note

Tighten each bolt a little at a time, apply uniform torque to all the bolts while fastening them. If leakage does not stop on completion of fastening, make sure that the pipe is not off center, then tighten the bolts little by little. Install the detector carefully so that the fastening torque does not exceed the prescribed limit. Otherwise, the detector could be damaged.

Accessory parts for installation

Introduction

The following parts are necessary for the installation of the detector:

- Gaskets: Provides gaskets by customer when using grounding rings made of SUS material.

Supplied gaskets as standard accessory, when using grounding rings made of other material.

Gaskets

Gaskets are supplied with the grounding ring, except when it is made of SUS material. Provides the gaskets by customer when you use a grounding ring made of SUS material. We recommend a non-rubber gasket material such as joint sheet or PTFE.

For the internal diameters of the gaskets, refer to Table 2-6.

- ~Note**
- *A gasket with small internal diameter may generate turbulent flow and affect, resulting in inaccurate measurements.*
 - *A gasket diameter with two large internal may cause leakage. Also, if there are any solids in the fluid to be measured, these may build up between the gasket and the flange, resulting in inaccurate measurements.*

Table 2-6 Recommended internal diameters of gaskets

Body diameter	Internal diameter (mm)
2.5 mm	11±1
5 mm	11±1
10 mm	11±1
15 mm (½ inch)	16±1
25 mm (1 inch)	25±1
40 mm (1½ inch)	40±1
50 mm (2 inches)	51±1
65 mm (2½ inches)	64±1
80 mm (3 inches)	76±1
100 mm (4 inches)	101±1
125 mm (5 inches)	124±1
150 mm (6 inches)	148±1
200 mm (8 inches)	196±1

Selecting an installation method

Caution



CAUTION

The necessary materials and the method of installation vary depending on the material of the grounding ring and the material. Select the applicable method of installation after checking the specifications of the detector to be installed and the conditions of installation. Improper installation may result in leakage or damage to the pipe flanges.

Installation method according to material

Select the appropriate installation method from the table below.

Pipe material	Grounding ring material	See page
Metal	SUS material	2-27
	Other than SUS material	2-28
PVC	SUS material	2-29
	Other than SUS material	2-32

Installation on metal pipe (1)

Introduction

The installation method described in this section is to be used with the following grounding ring materials. For the installation method used for any other grounding ring material, refer to the table on page 2-26.

Pipe material: Metal

Grounding ring material: SUS material

Required accessories

The following parts are required:

- Nuts and bolts
- Gaskets: We recommend non-rubber gaskets such as those made of joint sheet or PTFE. For recommended internal diameters, refer to Table 2-6 on page 2-25.

For the recommended internal diameter of the gaskets, see Table 2-2 on page 2-11.

Installation procedure

- Install the detector as shown in Figure 2-23. The torque level for tightening the bolts is not related to the gasket material. See Table 2-5 on page 2-23 for the appropriate torque. For the internal diameter of the gaskets, see Table 2-2 on page 2-11.

CAUTION

A lower fastening torque may result in insufficient surface pressure between the lining and the grounding ring, resulting in leakage.

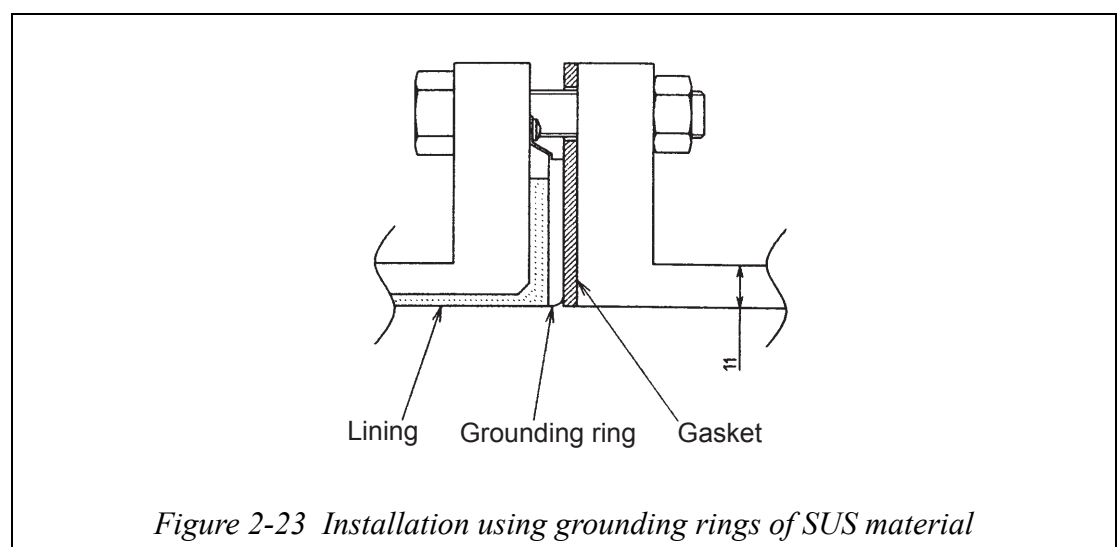

Installation on metal pipe (2)

Introduction

The installation method described in this section is to be used with the following grounding ring materials. For the installation method used with grounding rings of SUS material, refer to the table on page 2-26.

Pipe material: metal

Grounding ring material: other than SUS material

Required accessories

The following parts are required. No gaskets are necessary since PTFE gaskets are provided.

- Bolts and nuts

Installation procedure

- Install the detector as shown in Figure 2-24. See Table 2-5 on page 2-23 for the appropriate fastening torque.

CAUTION

Please note that the use of an additional gasket besides the existing PTFE gasket may result in leakage (see Figure 2-25).

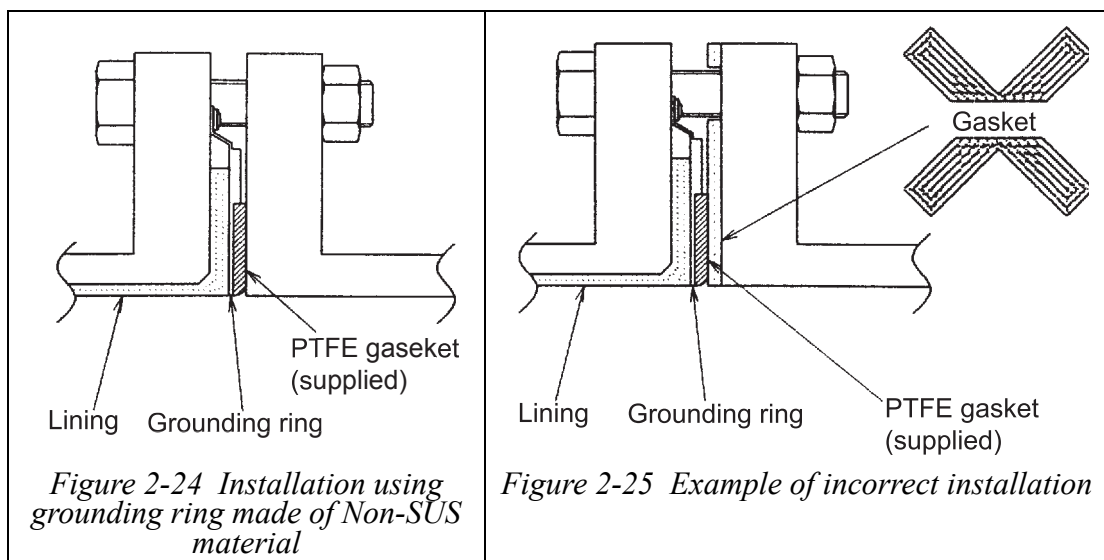

Installation on PVC pipe (1)

Introduction

The installation method described in this section is used for the following combination of pipe and grounding ring materials. For the installation method corresponding to any other combination, refer to the table on page 2-26.

Pipe material: PVC

Grounding ring material: SUS material

Required parts

The following parts are required:

- Through-bolts and nuts
- Gaskets: Non-rubber gaskets are recommended (i.e. joint sheet or PTFE). See Table 2-6 on page 2-25 for the recommended bore diameters. When using rubber gaskets, another gasket of the same material and with a thickness of 0.5 to 1.0 mm is required. See Table 2-3 on page 2-11 for the appropriated dimensions.
- Protective plate: Use a protective plate if bolt tightening to the specified torque threatens to warp or damage the PVC pipe. The plate material must be metal (such as stainless steel at least 6 mm thick) that will not deform when the nuts are tightened. For the shape of the protective plate, see Figure 2-27.

Installation procedure

The installation procedure varies depending on conditions such as the fastening torque and the need for a protective plate. Choose one of the following three methods as applicable.

1. Use this method to install the detector to the specified fastening torque. Install the detector as shown in Figure 2-26. The torque level for tightening the bolts is not related to the gasket material. See Table 2-5 on page 2-23 for the appropriate torque. For the internal diameter of the gaskets, see Table 2-2 on page 2-11.



CAUTION

Please note that the use of rubber gaskets and a lower fastening torque may result in insufficient surface pressure between the lining and the grounding ring, resulting in leakage.

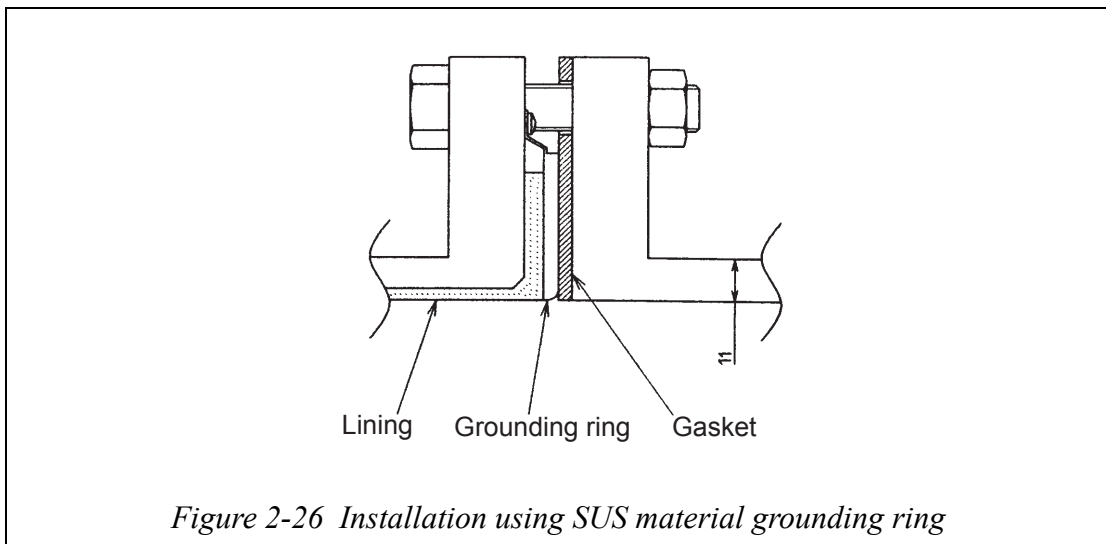

2. Use this method to install the detector using a protective plate to prevent PVC pipe from being deformed or damaged when the bolts are tightened to the specified torque.

Install the protective plate between the outer side of the PVC flange and the detector, as shown in Figure 2-27. The protective plate protects the PVC pipe from deformation or damage when secured at the specified torque. The torque level is unrelated to the pipe or grounding ring material. See Table 2-5 on page 2-23 for the appropriate torque. For the internal diameters of the gaskets, see Table 2-6 on page 2-25.

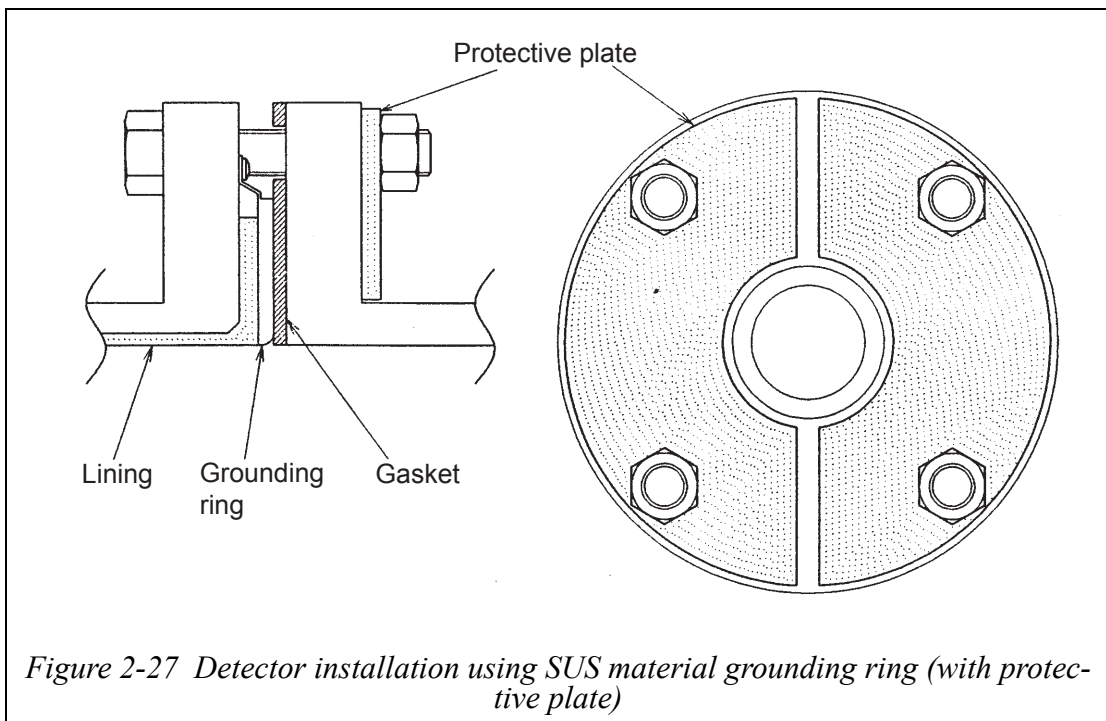

3. Use this method to install the detector using a low-fastening torque and rubber gaskets.

Remove the grounding ring from the detector, insert a rubber gasket 0.5 to 1.0 mm thick between the lining and the grounding ring, then reinsert the grounding

ring. Then remove the PTFE gasket, and attach a gasket 3 to 4 mm thick instead. Under these conditions, attach the detector to the pipe as shown in Figure 2-28. Fasten the bolts to a torque that provides a leakproof joint

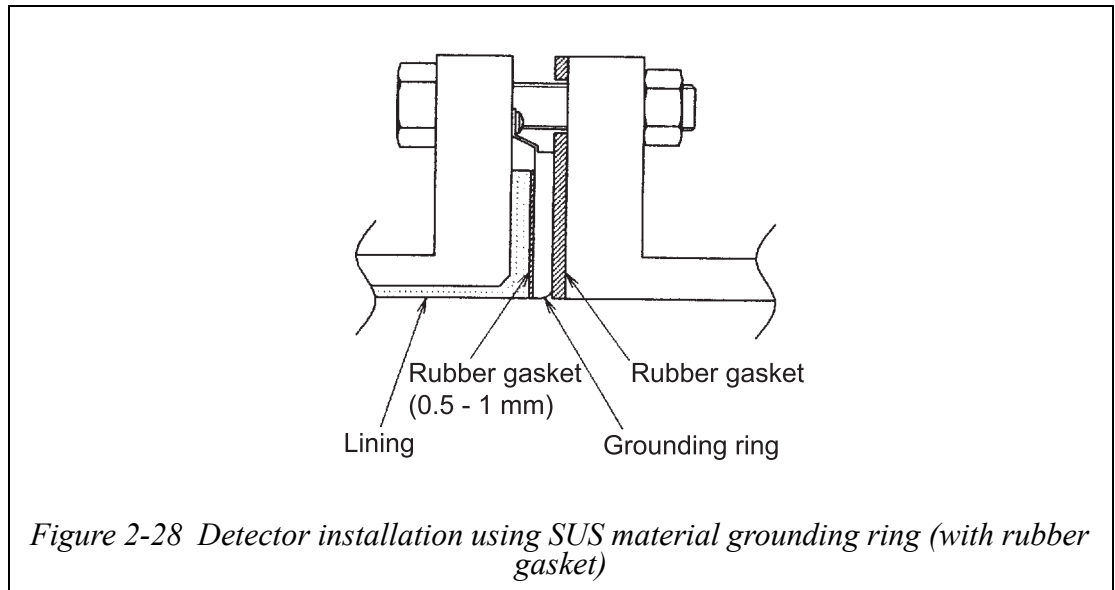

Installation on PVC pipe (2)

Introduction

The installation method described in this section is to be used for the following combination of pipe and grounding ring materials. For the installation method used for any other combination, refer to the table on page 2-26.

Pipe material: PVC

Grounding ring material: Other than SUS material

Required parts

The following parts are required:

- Through-bolts and nuts
- Gaskets: No gaskets are necessary due to the provision of a PTFE gasket. When using a rubber gasket, gaskets of the same material and of two thicknesses, 0.5 to 1.0 mm and 3.0 to 4.0 mm, are required. See Table 2-3 and 2-4 on page 2-11 for the appropriate dimensions.
- Protective plate: A protective plate is required if tightening the bolts to the specified torque may deform or damage the PVC pipe. Use stainless or hard metal 1 mm thick or more. For the shape of the metal, see Figure 2-30.

Installation procedure

The installation procedure varies depending on conditions such as the fastening torque and the need for a protective plate. Choose one of the following three methods as applicable.

1. Use this method to install the detector to the specified fastening torque. Install the detector as shown in Figure 2-29. See Table 2-5 on page 2-23 for the appropriate fastening torque. For dimensions of the rubber gaskets, see Table 2-3 and Table 2-4 on page 2-11

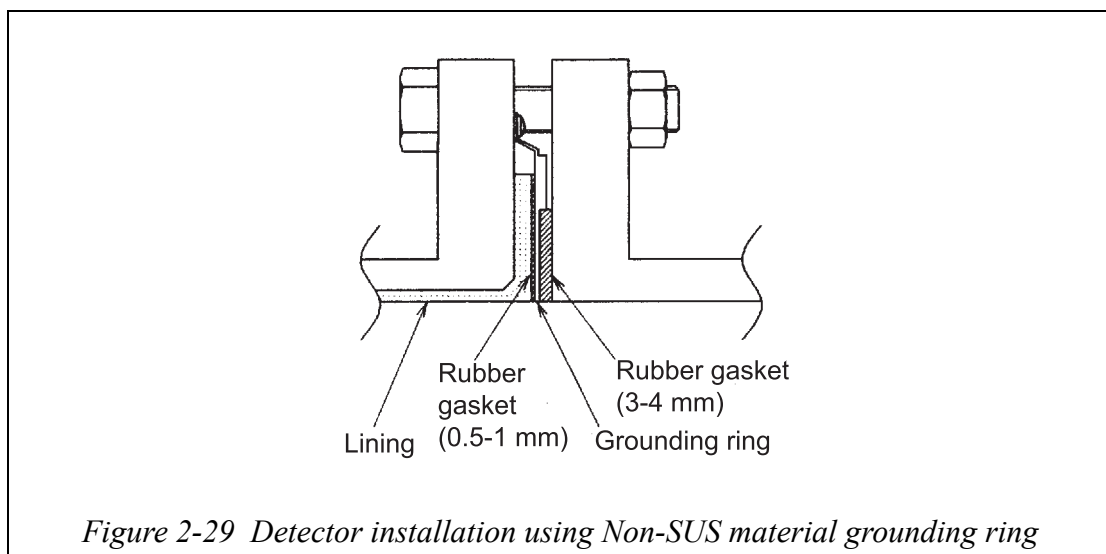

- Use this method to install the detector along with a protective plate to prevent PVC pipe from being deformed or damaged when the bolts are tightened to the specified torque.

Insert a protective plate between the outer side of the PVC flange and the detector as shown in Figure 2-30. The protective plate protects the PVC pipe from deformation or damage when it is secured to the specified torque. For the appropriate torque, see Table 2-5 on page 2-23.

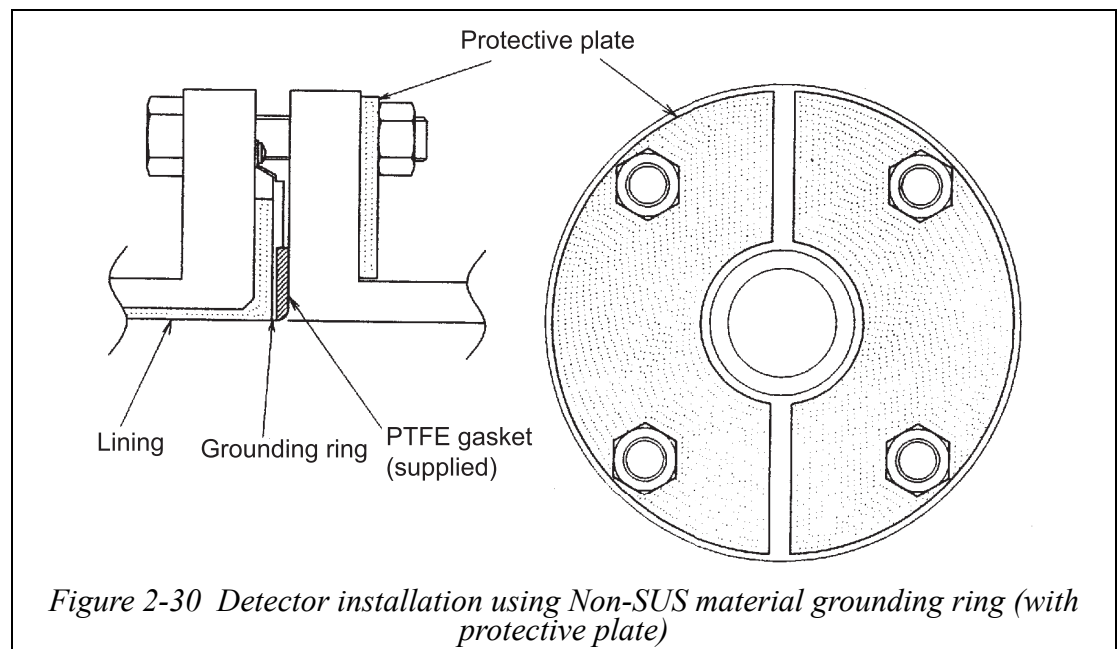

Figure 2-30 Detector installation using Non-SUS material grounding ring (with protective plate)

- Use this method to install the detector using a low fastening torque and rubber gaskets. First, remove the grounding ring from the detector, then insert a rubber gasket with a thickness of 0.5 to 1.0 mm. Then reinsert the grounding ring on top of the rubber gasket. Next, remove the PTFE gasket and insert a rubber gasket 3.0 to 4.0 mm thick to replace it. Under these conditions, install the detector on the pipe as shown in Figure 2-31. Tighten the bolts to the torque required to achieve a fluid seal for the rubber gasket. In this case, the two kinds of rubber gaskets that are used should be made of the same material. For the dimensions of the rubber gaskets, refer to Table 2-3 and Table 2-4 on page 2-11.

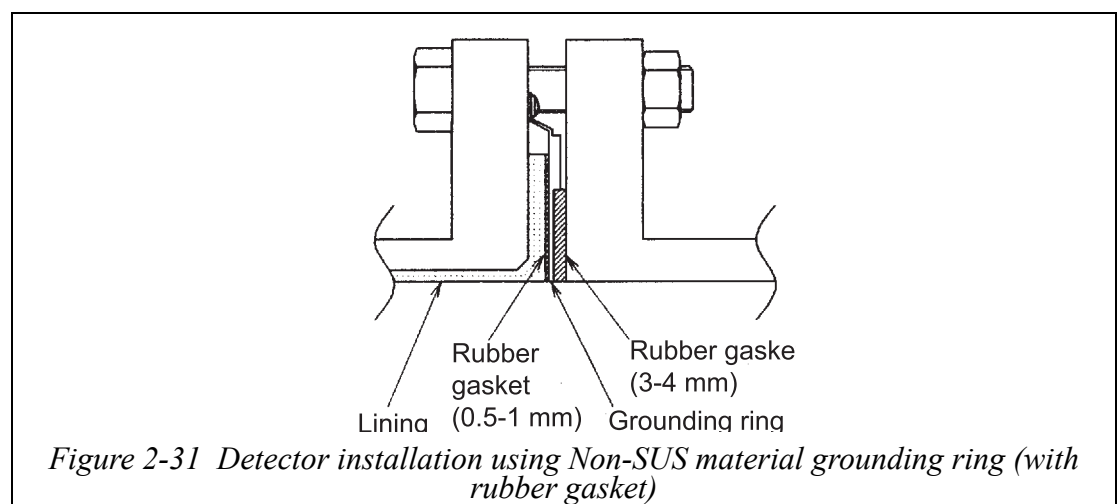

Figure 2-31 Detector installation using Non-SUS material grounding ring (with rubber gasket)

Chapter 3 : Electrical wiring

Outline of this chapter

This chapter describes the electrical wiring of the main unit, SFC and HART[®] Communicator.

3-1 : Electrical wiring

Electrical wiring

Introduction

For this instrument to operate, 15.6 to 42 V DC power supply is required to signals wiring. The electrical wiring of this instrument is described below as to the following items:

- Wiring cable connecting positions
- Dedicated cable connecting positions (detector and converter)
- Power source and load resistance
- Cable selection and cabling
- Grounding
- Wiring connection of power supply and analog current output
- Wiring connection for pulse output
- Wiring connection for contact output
- Wiring procedure

~Note *Do not connect commercial power directly to this instrument. Impressing commercial power on this instrument causes unrecoverable damage to the internal measuring circuit.*

Power and load resistance

Use a direct current (15.6 to 42 V DC) for the power.

Supply 50 V DC or over or 35 V AC or over causes unrecoverable damage to the instrument.

The power ripple should be 1 V or less in peak-to-peak value.

See that the load resistance of the loop wiring should within the operational range shown in Figure 3-1 with respect to the power supply voltage used.

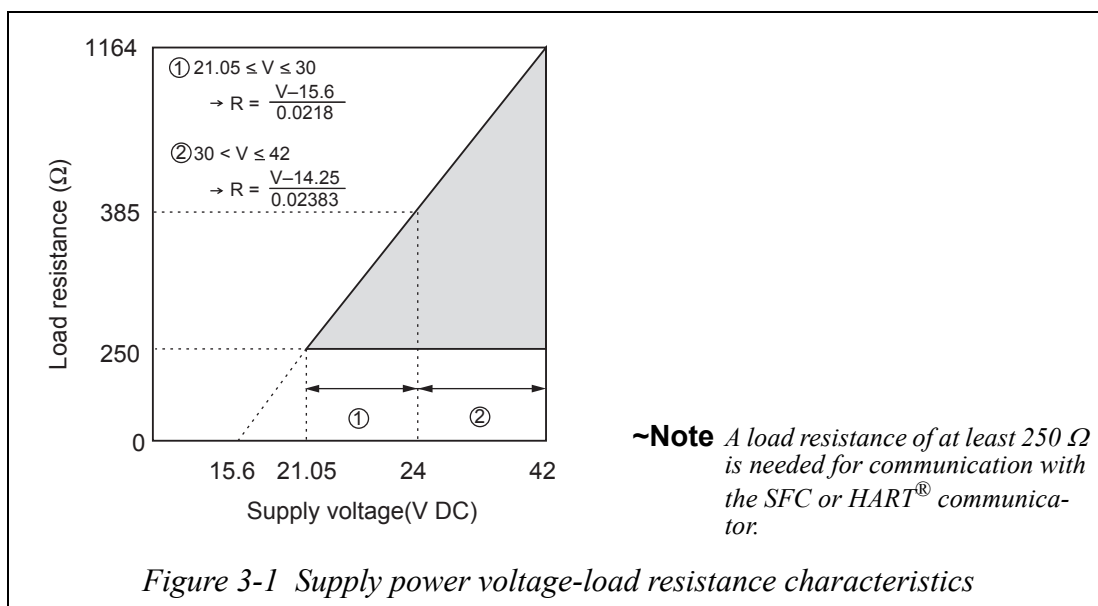

For a sequencer or other application that does analog/digital conversion of 4-20mA at high speed, use it after adding the following circuit in parallel with the load resistance.

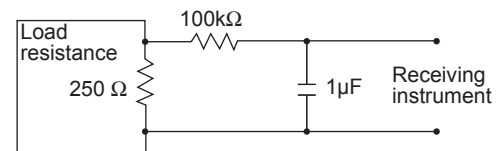

Selecting the wiring cable

For the electrical cable, we recommend 600 V vinyl insulation, vinyl sheath wire CVV with a conductor area of $2\ \text{mm}^2$ or a stranded wire cable having equivalent or superior performance.

For the wiring in a noisy place, we recommend a two-core shielded cable.

Select a sheath material that can endure the environment (ambient temperature, corrosive gas, corrosive fluid and the like) in which the cable is running.

The cable is wired in to the terminal box through a conduit cable ground (with G1/2 internal thread, CM20 internal thread or 1/2NPT internal thread). Therefore, the optimum cable external diameter is $\phi 11$.

For the terminal treatment of the cable, we recommend a crimp terminal (M4 screw) with an insulating sleeve.

The maximum length of wiring cable is 1500 meters.

Cabling

When running a cable between the instrument and a controller, pay attention to the following:

- The cabling should avoid a large-capacity transformer, motor, power source or other noise source. Do not put the cable in the same tray or duct with other power cables.
- For waterproofing and damage prevention of the wire, we recommend cabling work using conduits and ducts. Use a waterproof gland at the conduit cable ground.

Grounding (integral type)

For the grounding terminal, do grounding work (grounding resistance 100 Ω or less) according to Figure 3-2 or Figure 3-3. Do not ground both at the same time.

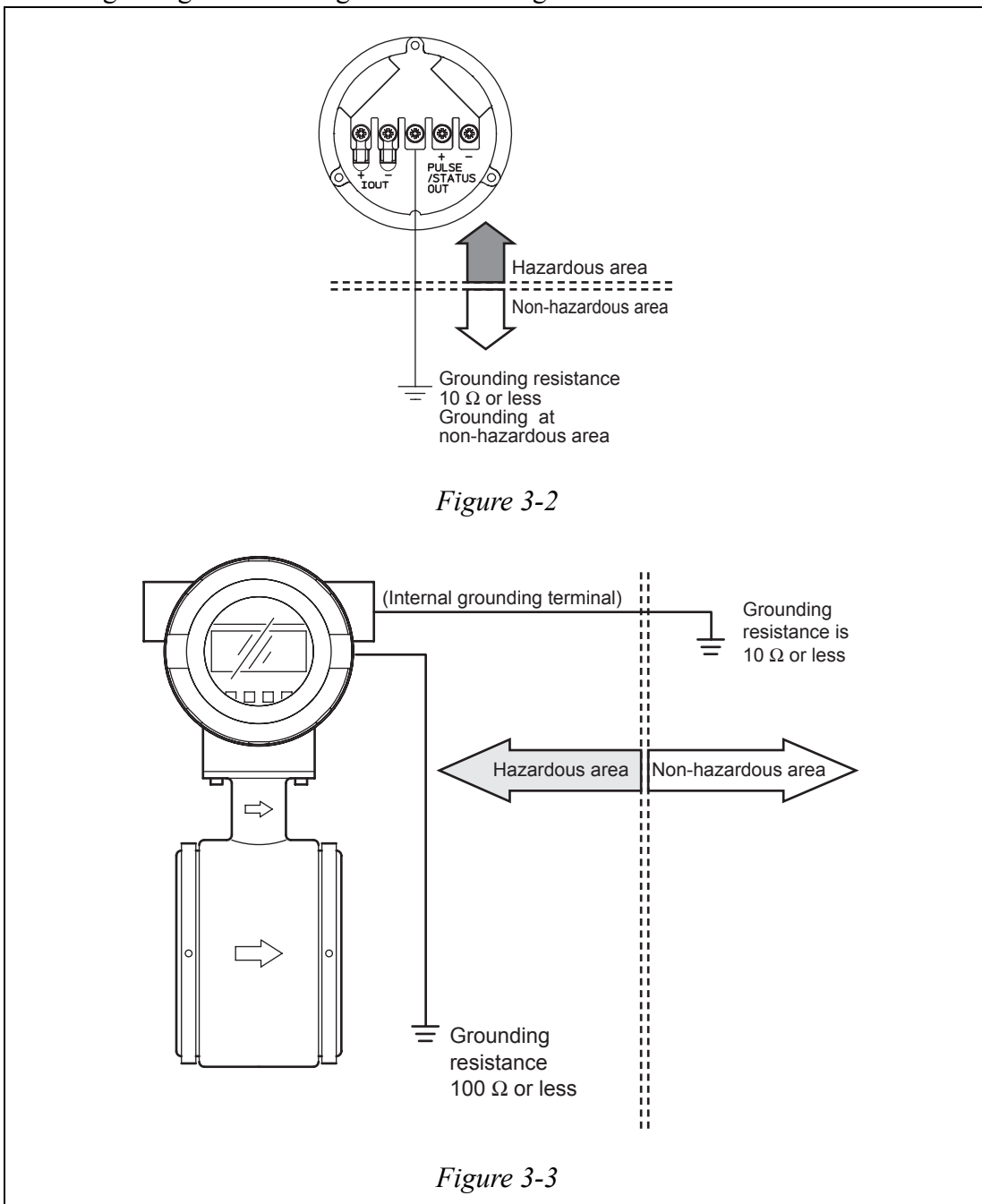

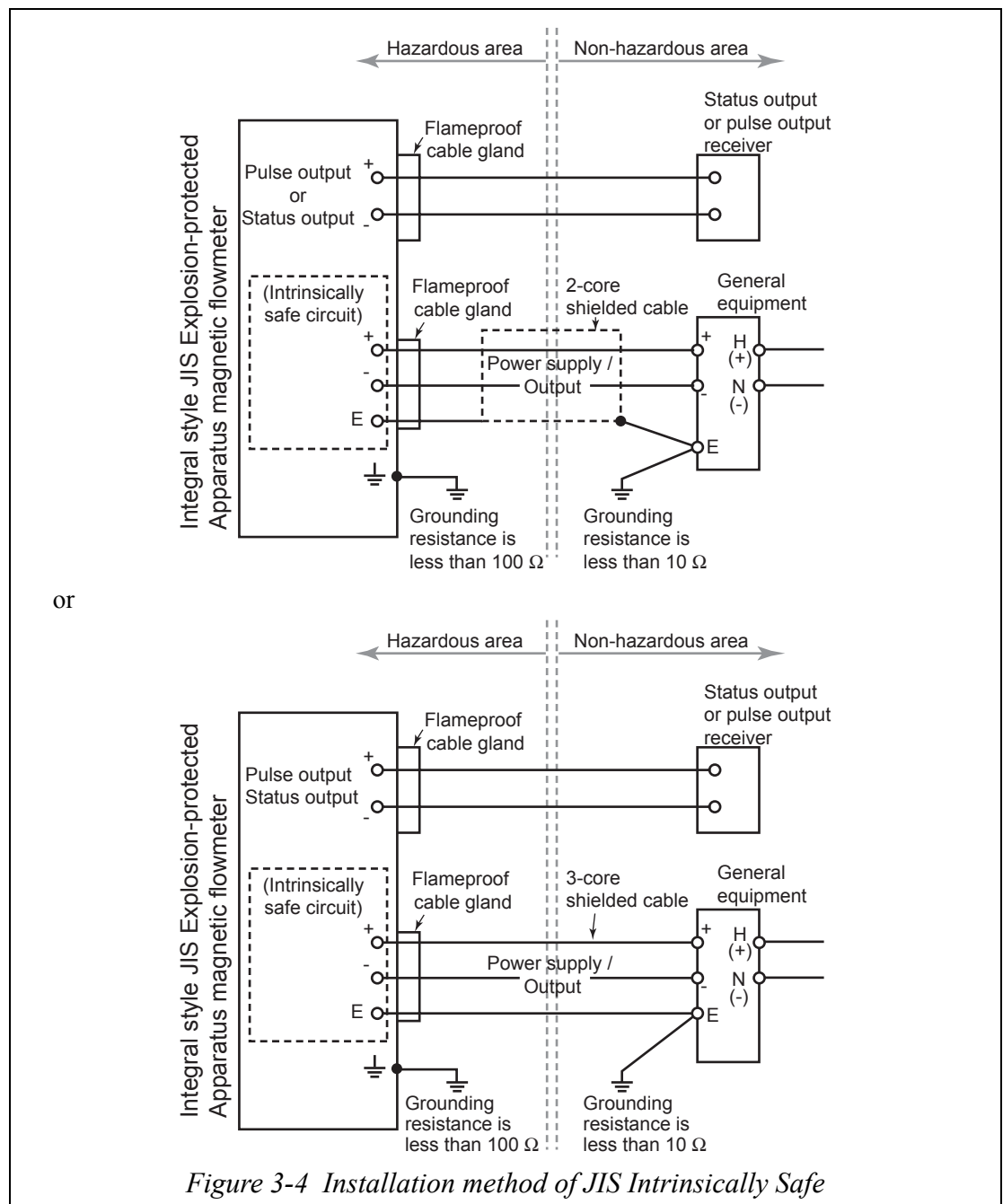
**CAUTION**

In accordance with the safety standards of flameproof regulation, please comply with the following instructions:

1. The voltage of general equipment such as the power supply and the receiver should not exceed 250 V AC, 50/60 Hz, 250 V DC at any time at normal or abnormal operation.
2.
 - 1) The ambient temperature around Magnetic Flowmeter is max.50°C (122°F).
 - 2) The fluid temperature is 125°C (257°F) max. (The line size 10 mm (3/8 inch) or less is 100°C (212°F).)
 - 3) Please use specified flameproof cable gland adaptors.
 - 4) Please do not open the case cover during operation.
 - 5) Please wait for seven minutes after switching OFF the power supply, before opening the front cover or side terminal cover.
3. A specified explosion-proof performance is available only when this electromagnetic flow meter is used according to the described specification.

Wiring connection of power supply and analog current output

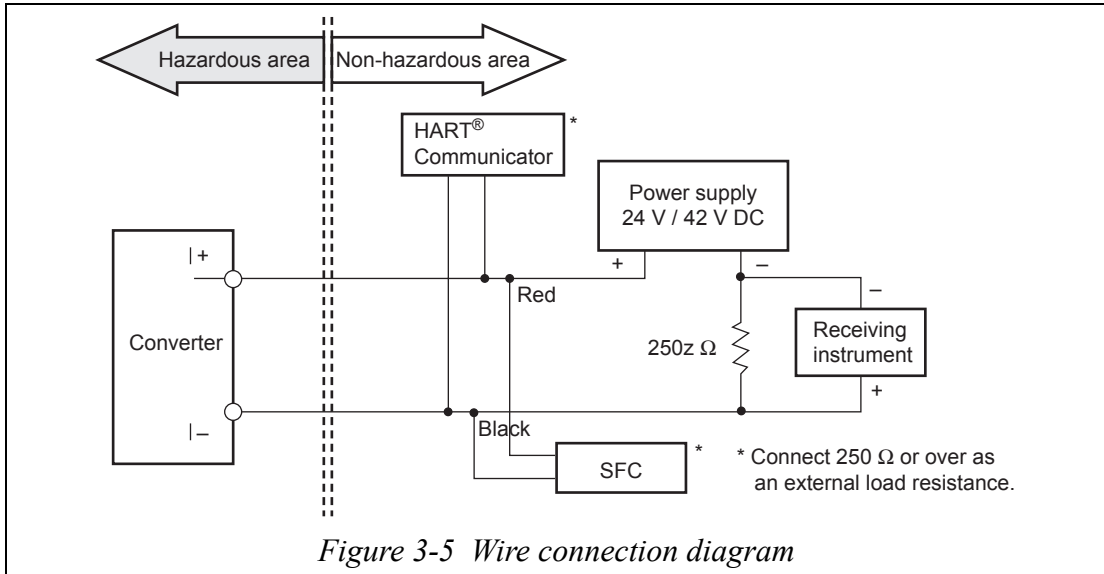

Figure 3-5 Wire connection diagram

CAUTION

- Incorrect wiring polarity can do damage to the equipment. Double-check the wiring position.
- The SFC and HART® Communicator cannot be used simultaneously.
- Only the communication method selected by the data setter is available.

Wiring connection for pulse output

The pulse output is an open-collector output.

Do wiring paying attention to the voltage and polarity.

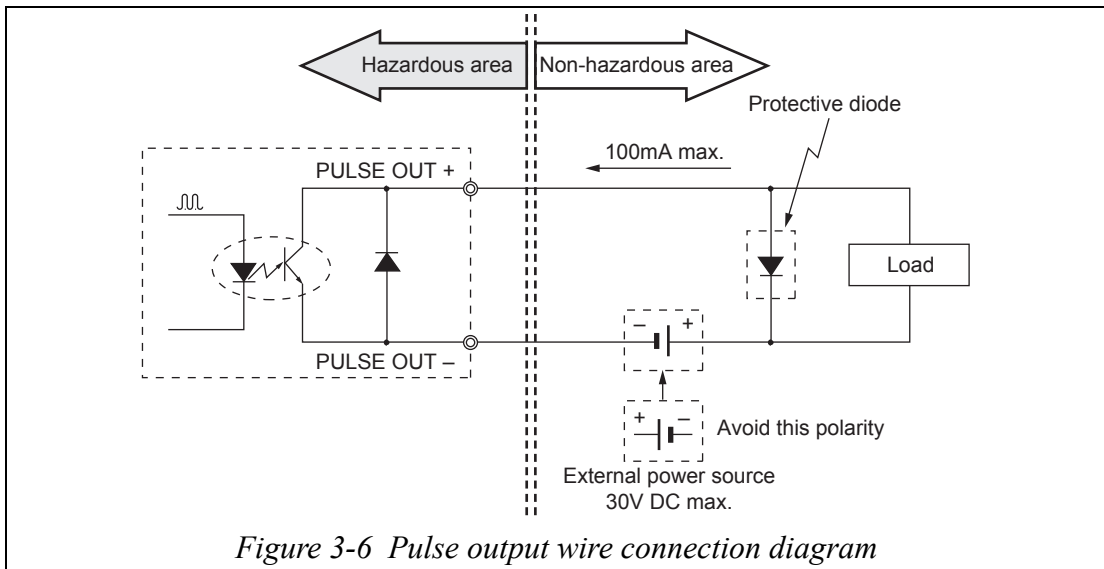

Figure 3-6 Pulse output wire connection diagram

CAUTION

- Incorrect wiring polarity can do damage to the equipment. Double-check the wiring position.
- Use an external power source that meets the voltage and capacity specifications.

Wiring connection for contact output

Because of an open-collector output, do wiring paying attention to the polarity.

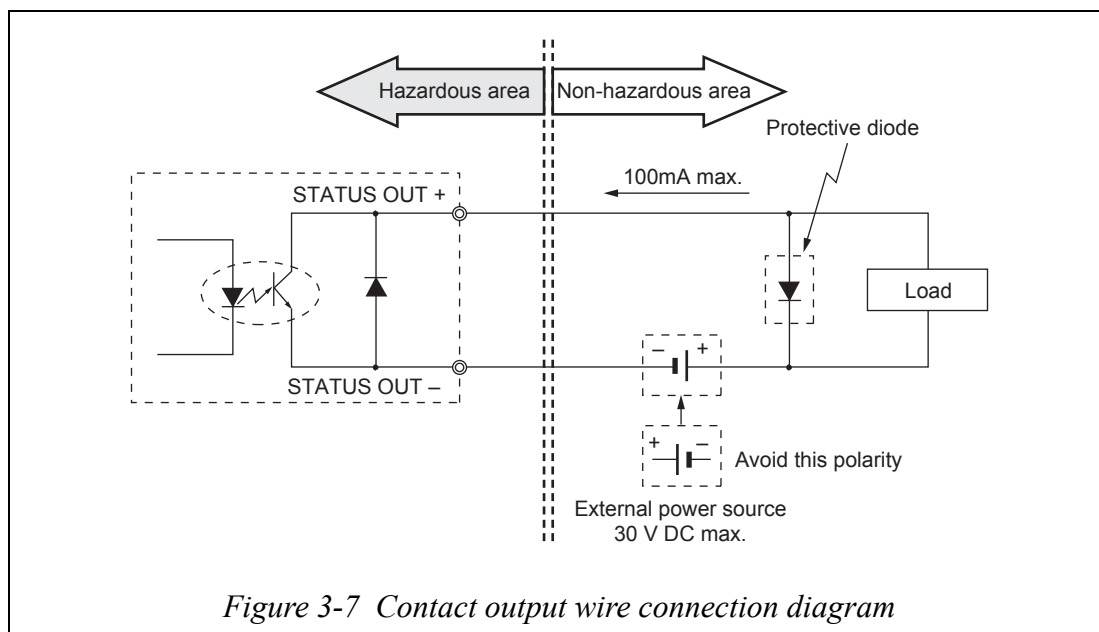

CAUTION

Incorrect wiring polarity can do damage to the equipment. Double-check the wiring position.

Use an external power source that meets the voltage and capacity specifications.

Wiring procedure

Do wiring between the instrument and a power supply according to the following procedure.

Step	Procedure
1	The terminal box cover is fixed by hexagon socket head setscrews (M3). Loosen the setscrews with an Allen wrench (1.5).
2	Remove the terminal box cover by turning it counterclockwise with the dedicated tool.
3	Remove the dust plug in the socket for an output signal line conduit.
4	Insert the cable into the conduit cable ground. ~Note <i>Take care not to do damage to the cable sheath.</i>
5	Referring to Figure 3-6, connect the cable to the output signal terminals (IOUT+, -) of the terminal box. ~Note <ul style="list-style-type: none"> • <i>Pay attention to the polarity.</i> • <i>Tighten the terminal screws well. The recommended tightening torque is 1.1 ft·lb (1.5 N·m).</i>
6	Waterproof the conduit sufficiently to prevent rainwater or the like from getting in. ~Note <i>We recommend using a silicon resin-based non-curing sealant.</i>
7	Attach the terminal box cover and tighten it well with the dedicated tool. Then, fix the cover with the setscrews. ~Note <i>Take care not injure your fingers on the cover edge or the thread in the case.</i>

Wiring for power supply

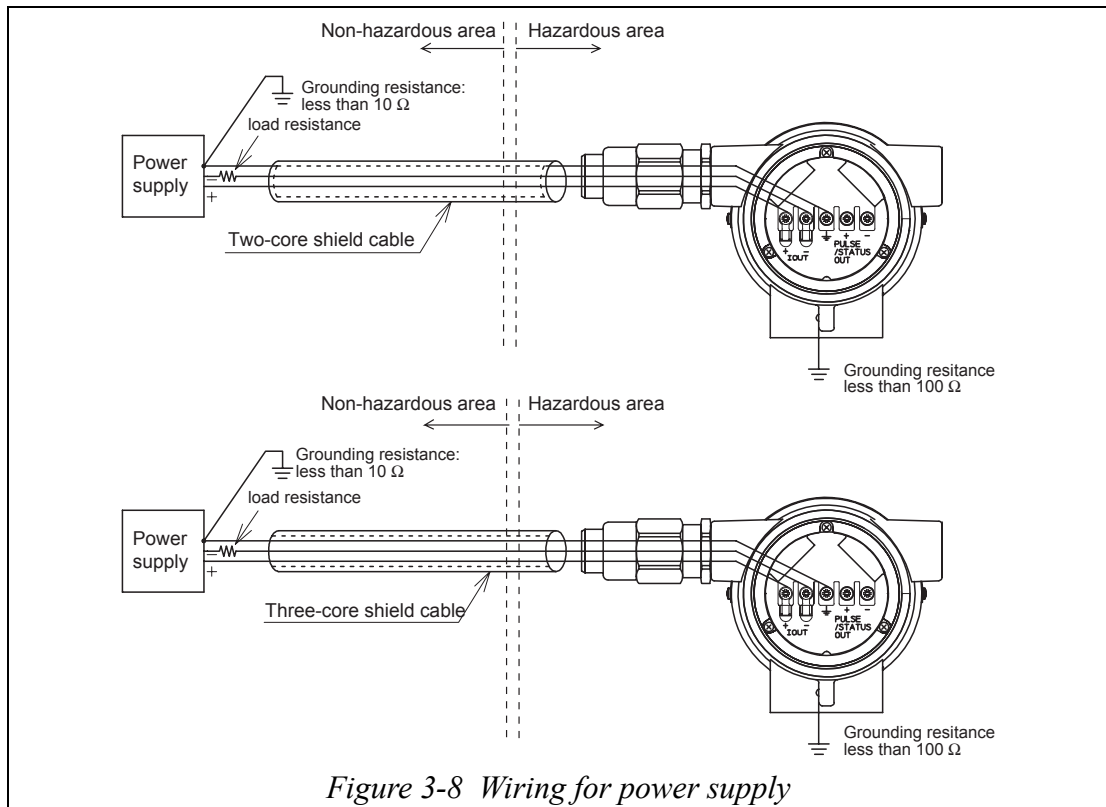

Figure 3-8 Wiring for power supply

Chapter 4 : Start and stop operation procedure for model MTG

Outline of this chapter

This chapter describes the procedure to start the instrument and do zero adjustment.

When starting and operating the instrument for the first time, follow the descriptions in this chapter.

4-1 : Confirmation before start

Introduction

Before you start up the instrument, confirm the following items. Numbers in parentheses indicate the chapter to which to refer.

- (1) Confirm that the electromagnetic flowmeter is installed correctly in the pipes (Chapter 3 : Electrical wiring).
- (2) Confirm that the electrical wiring is correct (Chapter 3 : Electrical wiring).
- (3) If communication is required, confirm that the communication equipment is wired correctly (Volume on Communication).
- (4) Fill the electromagnetic flowmeter's detector with a fluid and do zero adjustment in a static state (Chapter 5 : Operation using the data setting device).
- (5) Confirm that there is no leakage at the joint of the electromagnetic flowmeter's detector (Chapter 3 : Electrical wiring).
- (6) Confirm that the electromagnetic flowmeter's detector is filled with water and there are no stagnant bubbles.
- (7) Turn on power and warm up for 30 minutes.
- (8) Confirm whether the settings of the data sheet inserted in the converter have been attained. If there is need to change settings to meet your usage, change them using the data setter or the like.

- ~Note**
- *If the detector is not filled with water or many bubbles have adhered inside, the indication may not reach zero flow rate. In such cases, make a flow of water once to ensure that the detector is free of bubbles and filled with water.*
 - *With incorrect grounding, the indication of flow rate may fluctuate largely. In such cases, check the grounding condition.*

4-2 : Stopping

~Note *When stopping the instrument from operation and shutting down the output to control equipment, always change over the control equipment to manual control. This is for preventing the instrument's output shutdown from directly influencing the control equipment.*

Procedure

When stopping the instrument, follow the following procedure:

Step	Procedure
1	Change over the control equipment of this instrument to be stopped to manual control.
2	Turn off power.

Chapter 5 : Operation using the data setting device

This section describes how to operate this system from the data setting device. This system configuration and settings can be made using the four keys on the data setting device.

5-1 : Startup

Introduction

With the model MTG, all settings can be configured from the data setting unit.

Startup

When the power supply is turned on, the display changes in the order of OVERALL DISPLAY, SELF CHECK MODE, and MEASURING MODE.

OVERALL DISPLAY

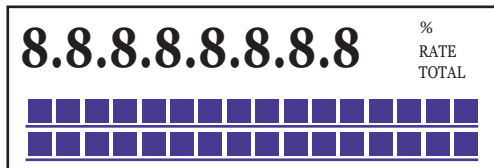

8.8.8.8.8.8.8.8
 Main display: 7-segment, 8-digit display
 % flow rate Actual flow rate Integration value
 ■■■■■■ Unit display
 ■ Sub-display Display screen for setting
 Displayed for 2 seconds.



SELF CHECK MODE



Main display 7-segment, 8-digit blinks.
 The display (-) moves from left to right.
 Sub display: SELF CHECK MODE
 Displayed for 5 seconds



MEASURING MODE

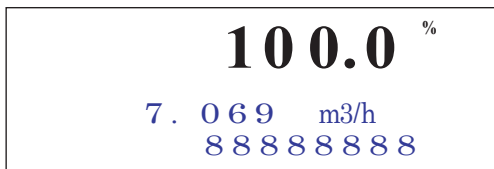

Display and operation contents of data setting device

Overview of mode

This system provides the following four modes available in accordance with the operations:

Mode	Description
MEASURING MODE	Mode that shows measuring status.
OPERATOR'S MODE	<p>Mode that is set for the operator. This mode is comprised of setting and configuration of data that are set or changed frequently during startup. In this mode, settings can be changed only when the write protect levels are set to 0, 1 and 2. At level 3, only the set data can be checked. (See "5-3-2 : Display of write protect level")</p> <p>[Damping constant, auto zero adjustment, counter reset, counter preset value, etc.]</p> <div data-bbox="794 779 1449 1070" style="border: 1px solid black; padding: 5px;"> <p style="text-align: center;">⚠ CAUTION</p> <p>Set or changed data are temporarily written into the memory. Note that if the configured data are not saved/written into the memory within 10 minutes, the configured data returns to the previous values. Be sure to press the MODE key to return to the MEASURING MODE and to save data.</p> </div>
ENGINEERING MODE	<p>In the set mode for engineering, the mode is comprised of data that is set or changed less frequently than the data in "OPERATOR'S MODE."</p> <p>Data can be set and changed at write protect level 0 or 1. At level 2 or 3, only the set data check is allowed.</p> <p>[ID, function selection, detector data, flow rate range, hysteresis width, pulse data, low flow cut, selecting false mode for output, etc.]</p> <div data-bbox="794 1406 1449 1899" style="border: 1px solid black; padding: 5px;"> <p style="text-align: center;">⚠ CAUTION</p> <ul style="list-style-type: none"> • When the mode is changed to MEASURING MODE by pressing the MODE key, the set/changed data are saved into a non-volatile memory. Be sure to press the MODE key, to save the configured data. • Set or changed data are temporarily written into the memory. Note that if the configured data are not saved/written into the memory within 10 minutes, the configured data returns to the previous values. Be sure to press the MODE key to return to the MEASURING MODE and to save data. </div>

Mode	Description
<p>MAINTENANCE MODE</p>	<p>A mode for maintenance that is used when adjustments and checks are needed for regular maintenance and when troubles occur. Adjustments and checks are allowed only at write protect level 0. [Loop check, output adjustment, gain adjustment, etc.] This mode is furthermore divided into the following three types: OUTPUT CHECK MODE CALIBRATION MODE CRITICAL MODE</p> <div data-bbox="700 573 1353 862" style="border: 1px solid black; padding: 5px;"> <p style="text-align: center;">⚠ CAUTION</p> <ul style="list-style-type: none"> • CALIBRATION MODE and CRITICAL MODE contains very important adjustment values or operations for the flow rate measurement. Wrong settings make accurate flow rate measurement impossible. For the operation, contact our service engineers. </div> <div data-bbox="700 900 1353 1391" style="border: 1px solid black; padding: 5px; margin-top: 10px;"> <p style="text-align: center;">⚠ CAUTION</p> <ul style="list-style-type: none"> • When the mode is changed to MEASURING MODE by pressing the MODE key, the set/changed data are saved into a non-volatile memory. Be sure to press the MODE key, to save the configured data. • Set or changed data are temporarily written into the memory. Note that if the configured data are not saved/written into the memory within 10 minutes, the configured data returns to the previous values. Be sure to press the MODE key to return to the MEASURING MODE and to save data. </div>

5-2 : Functions of the data setting device

5-2-1 : Data setting device

Name of parts

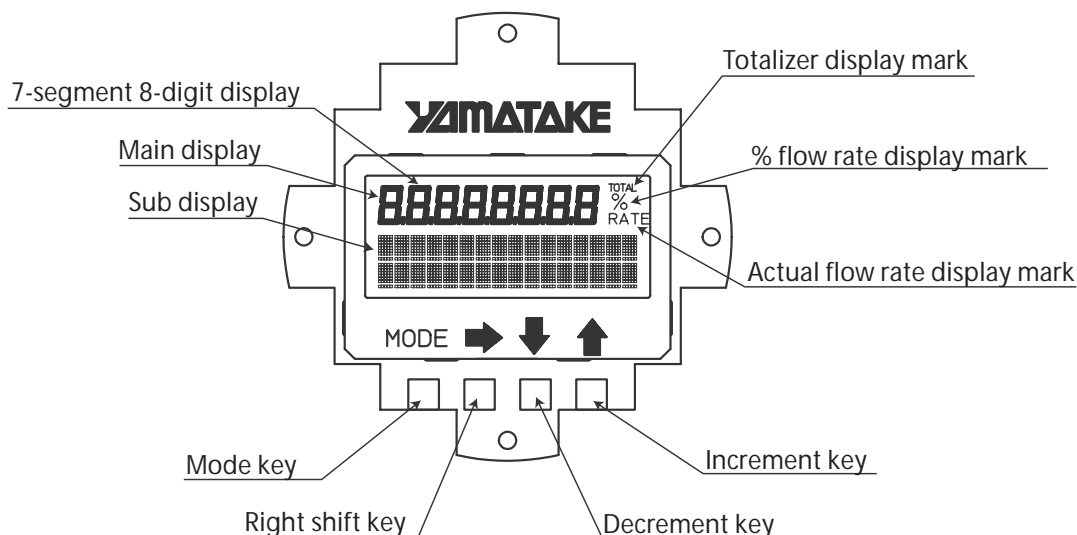

Names and Descriptions of Parts

This section describes displays shown on the data setting device.

- Flow rate display

The flow rate display is given at three stages: % flow rate, actual flow rate and totalized value. Operating the key, the main display to be shown at the top stage can be set selecting from the actual flow rate, % flow rate and totalized value. RATE appears for the actual flow rate display, % for the % flow rate display, and TOTAL for the totalized value display (see “5-3-1 : Display overview”).



Area	Description
Main display 7-segment 8-digit display	Displays the flow rate display selected for the main display by DISP SELECT in OPERATOR'S MODE.
% flow rate display mark (%)	Displays when % flow rate is shown for the main display.
Actual flow rate display mark (RATE)	Displays when the actual flow rate is shown for the main display.
Totalized value display mark (TOTAL)	Displays when the totalized value is shown for the main display.
Sub display	<ul style="list-style-type: none"> In MEASURING MODE, shows a flow rate display other than a flow rate display selected for the main display by DISP SELECT in OPERATOR'S MODE. In modes other than MEASURING MODE, indicate procedures for setting and adjusting parameters.

This section describes keys on the data setting device.

Name	Description
MODE key	<ul style="list-style-type: none"> Enters OPERATOR'S MODE. When parameters and configured data have been changed in ENGINEERING MODE or MAINTENANCE MODE, press this key to save the data.
Right shift key	<ul style="list-style-type: none"> Moves the cursor to the right.
Decrement key	<ul style="list-style-type: none"> Changes the parameter at a cursor position. Displays the previous screen. <div style="display: flex; justify-content: space-between;"> <div style="border: 1px solid black; padding: 5px; width: 40%;"> <p>* OPERATOR'S MODE</p> <p>Cursor</p> </div> <div style="width: 55%;"> <p>If the key is pressed, when the cursor is placed at the upper left end (*, #, >), the screen will change</p> </div> </div> <div style="display: flex; justify-content: space-between; margin-top: 10px;"> <div style="border: 1px solid black; padding: 5px; width: 40%;"> <p>* DAMPING 001.0 S</p> <p>Cursor</p> </div> <div style="width: 55%;"> <p>If the key is pressed, when the cursor is placed at a number, the number is decremented.</p> </div> </div> <div style="display: flex; justify-content: space-between; margin-top: 10px;"> <div style="border: 1px solid black; padding: 5px; width: 40%;"> <p># 1.0000 m/s SPAN 07_069 m³/h</p> <p>Cursor</p> </div> <div style="width: 55%;"> <p>If the cursor is placed at a decimal point, the decimal point moves rightward.</p> </div> </div>
Increment key	<ul style="list-style-type: none"> Changes the parameter at a cursor position. Displays the following screen. <div style="display: flex; justify-content: space-between;"> <div style="border: 1px solid black; padding: 5px; width: 40%;"> <p>* OPERATOR'S MODE</p> <p>Cursor</p> </div> <div style="width: 55%;"> <p>If the key is pressed, when the cursor is placed at the upper left end (*, #, >), the screen will change.</p> </div> </div> <div style="display: flex; justify-content: space-between; margin-top: 10px;"> <div style="border: 1px solid black; padding: 5px; width: 40%;"> <p>* DAMPING 001.0 S</p> <p>Cursor</p> </div> <div style="width: 55%;"> <p>If the key is pressed, when the cursor is placed at a number, the number is incremented.</p> </div> </div> <div style="display: flex; justify-content: space-between; margin-top: 10px;"> <div style="border: 1px solid black; padding: 5px; width: 40%;"> <p># 1.0000 m/s SPAN 07_069 m³/h</p> <p>Cursor</p> </div> <div style="width: 55%;"> <p>If the key is pressed, when the cursor is placed at a decimal point, the decimal point moves to the left.</p> </div> </div> <div style="display: flex; justify-content: space-between; margin-top: 10px;"> <div style="border: 1px solid black; padding: 5px; width: 40%;"> <p>* AUTO ZERO READY</p> <p>Cursor</p> </div> <div style="width: 55%;"> <p>If the cursor is placed over READY, pressing the key starts operation.</p> </div> </div>

5-3 : Description of MEASURING MODE

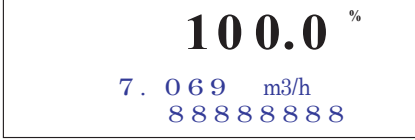
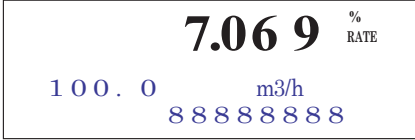
5-3-1 : Display overview

<p>% flow rate display</p> 	<p>1st line (Main display): 7-segment 4-digit display % flow rate (%)</p> <p>2nd line: Actual flow rate display (Significant value of 5 digits)</p> <p>3rd line: Totalized value display (Significant figure of 8 digits)</p> <p>Write protect level display (WP0 to 3)</p>
<p>Actual flow rate display</p> 	<p>1st line (Main display): 7-segment 4-digit display Actual flow rate (RATE)</p> <p>2nd line: % flow rate display (Significant figure of 4 digits), unit of actual flow rate</p> <p>3rd line: Totalized value display (Significant figure of 8 digits)</p> <p>Write protect level display (WP0 to 3)</p>
<p>Totalizer display</p> 	<p>1st line (Main display): 7-segment 8-digit display Totalized value (TOTAL)</p> <p>2nd line: Actual flow rate display (Significant figure of 4 digits)</p> <p>3rd line: % flow rate display (Significant figure of 4 digits)</p> <p>Write protect level display (WP0 to 3)</p>

Totalization is not performed, when the output selection is set to the contact output. However, the previous value is displayed as the totalized value.

* Details on display

- % flow rate display:** The % flow rate display range is from -115.0% to 115.0%. A value up to the first decimal place is displayed. The position of the decimal point is fixed. The integer part to be displayed has up to three digits (0 to 115). In the main display, unnecessary zeros are deleted (but are not deleted in the sub display).
Example) 019.8% → 19.8%
 -000.5% → -0.5%
- The position of the negative sign (-) is fixed. (The positive sign is not displayed.)
- Actual flow rate display:** The flow rate displayed in the actual flow rate display is up to 115% of the range or the equivalent. However, if the flow rate equivalent to 115% of the range exceeds the range of significant figure, the highest value (e.g., 9.999) will be displayed. In the main display, unnecessary zeros are deleted (but are not deleted in the sub display).

Totalized value display: An totalized value is displayed in 8 digits without signs and decimal points.

In the main display, unnecessary zeros are deleted (but are not deleted in the sub display).

Next to 99999999, totalization starts from 00000000.

5-3-2 : Display of write protect level

Protect level

The write protect levels and their corresponding settings and operating condition are shown below.

Write protect level	SW1	SW2	LSC (Key operation)			Communication		
			OPERATOR'S MODE	ENGINEERING MODE	MAINTENANCE MODE	OPERATOR'S MODE	ENGINEERING MODE	MAINTENANCE MODE
0	OFF	OFF	R/W ENABLE	R/W ENABLE	R/W ENABLE	R/W ENABLE	R/W ENABLE	R/W ENABLE
1	ON	OFF	R/W ENABLE	R/W ENABLE	R/W ENABLE	R ONLY	R ONLY	R ONLY
2	OFF	ON	R/W ENABLE	R ONLY	R/W ENABLE	R ONLY	R ONLY	R ONLY
3	ON	ON	R ONLY	R ONLY	R/W ENABLE	R ONLY	R ONLY	R ONLY

R/W: Read and write (Reads and writes set values.)

R: Read

W: Write

ENABLE: Enabled

Disable: Disabled

ONLY: Only the indicated operation is enabled.

~Note *Be sure to turn off the power supply before changing the write protect level dip switch settings.*

Settings of write protect switches

SW No.	At shipment
S1	Determined by WP LEVEL.
S2	Determined by WP LEVEL.
S3	ON (No data change is allowed.)

Main board

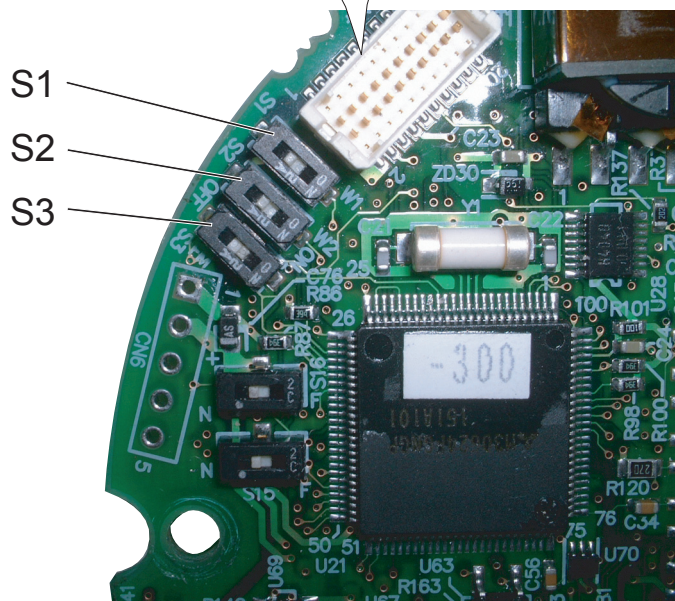
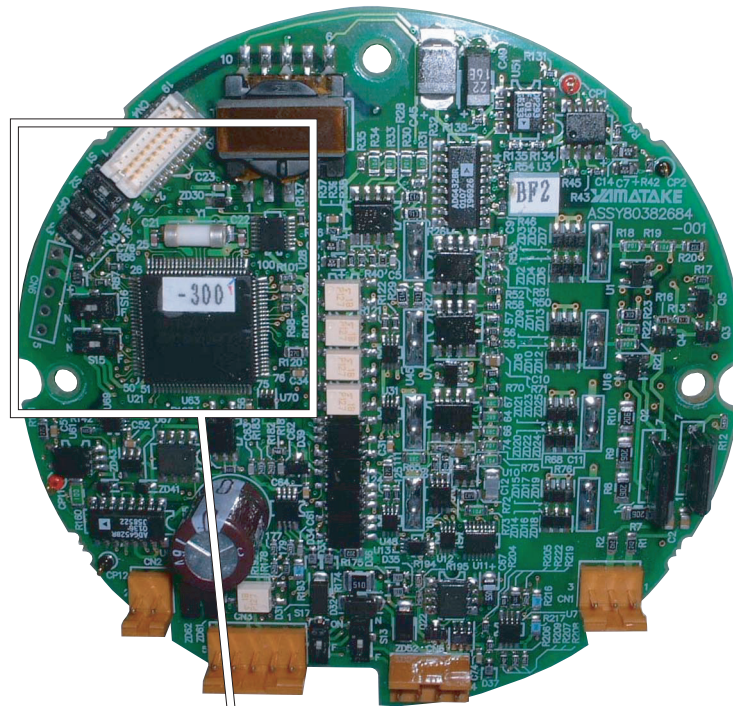

5-4 : Overview of operation using the data setting device

Introduction

The data setting device has three types of modes: OPERATOR'S MODE, ENGINEERING MODE, and MAINTENANCE MODE. MAINTENANCE MODE is furthermore divided into three of sub-modes: OUTPUT, CALIBRATION, and CRITICAL. The screen flow is as follows:

Entire display flow 1

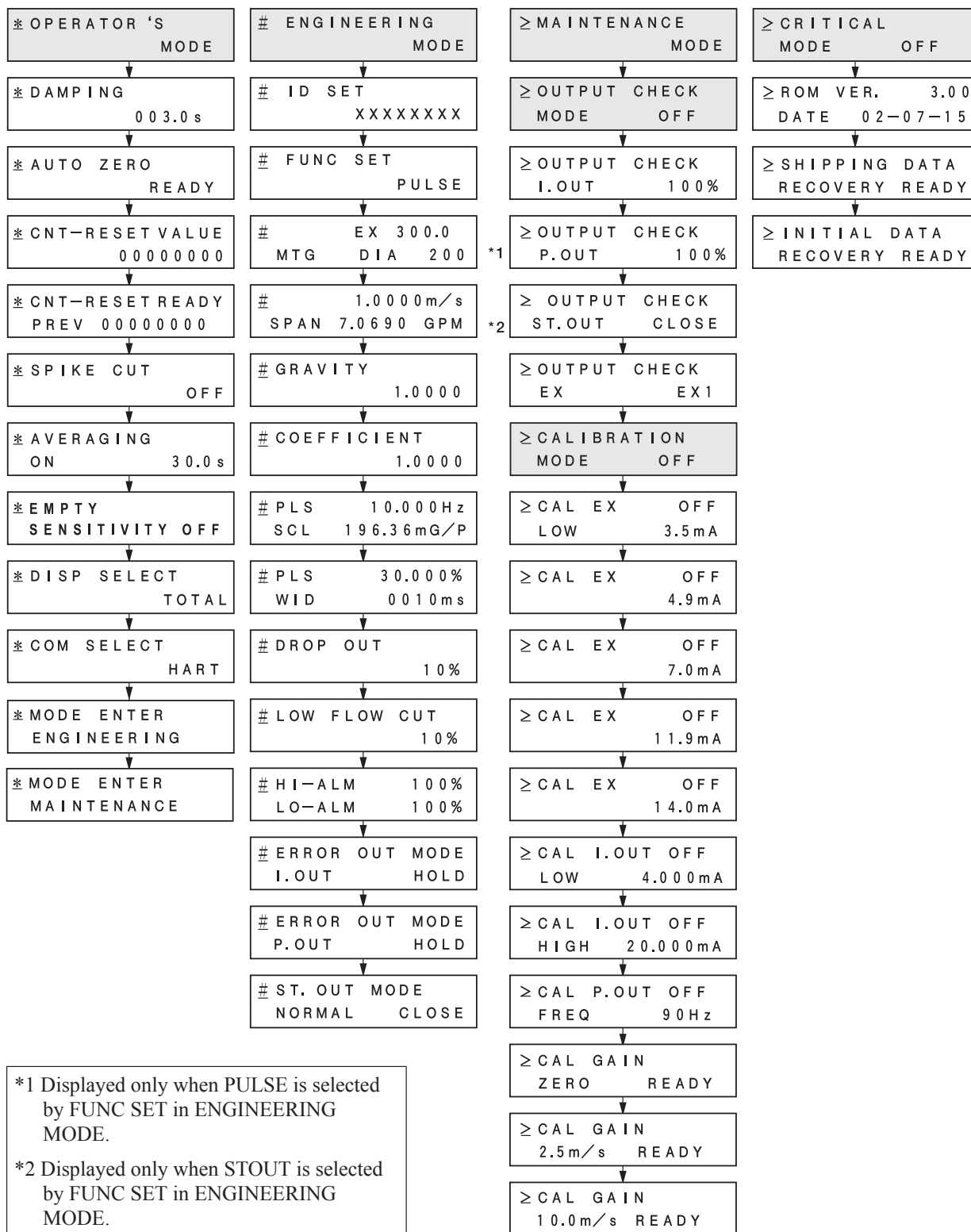

*1 Displayed only when PULSE is selected by FUNC SET in ENGINEERING MODE.
 *2 Displayed only when STOUT is selected by FUNC SET in ENGINEERING MODE.

5-5 : Configuration of OPERATOR'S MODE

Introduction

OPERATOR'S MODE provides the following setting and adjustment items.

For details on functions in the items, see “5-5-1 : Changing setting of damping time constant” and later.

Item	Contents	Screen
DAMPING	Sets a damping time constant.	<div style="border: 1px solid black; padding: 5px; text-align: right;"> 20.0 % * DAMPING 005.0 s </div>
AUTO ZERO	Auto zero adjustment	<div style="border: 1px solid black; padding: 5px; text-align: right;"> 20.0 % * AUTO ZERO READY </div>
CNT-RESET VALUE	Sets a built-in counter reset value.	<div style="border: 1px solid black; padding: 5px; text-align: right;"> 20.0 % * CNT-RESET VALUE 0 0 0 4 4 4 4 </div>
CNT-RESET READY	Resets totalized value to a built-in counter reset value.	<div style="border: 1px solid black; padding: 5px; text-align: right;"> 20.0 % * CNT-RESET READY 0 0 0 0 0 0 0 0 </div>
SPIKE CUT	Sets auto spike cut.	<div style="border: 1px solid black; padding: 5px; text-align: right;"> 20.0 % * SPIKE CUT OFF </div>
AVERAGING	Sets a moving average function.	<div style="border: 1px solid black; padding: 5px; text-align: right;"> 20.0 % * AVERAGING OFF </div>
DISP SELECT	Selects either % flow rate, actual flow rate or totalized value to be displayed in the main display.	<div style="border: 1px solid black; padding: 5px; text-align: right;"> 20.0 % * DISP SELECT % </div>
COM SELECT	Selects a communication method.	<div style="border: 1px solid black; padding: 5px; text-align: right;"> 20.0 % * COM SELECT SFN. A </div>
MODE ENTER ENGINEERING	Enters the ENGINEERING MODE.	<div style="border: 1px solid black; padding: 5px; text-align: right;"> 20.0 % * MODE ENTER ENGINEERING </div>
MODE ENTER MAINTENANCE	Enters the MAINTENANCE MODE.	<div style="border: 1px solid black; padding: 5px; text-align: right;"> 20.0 % * MODE ENTER MAINTENANCE </div>

LCD display flow

The LCD display flow of the OPERATOR'S MODE is as shown below:

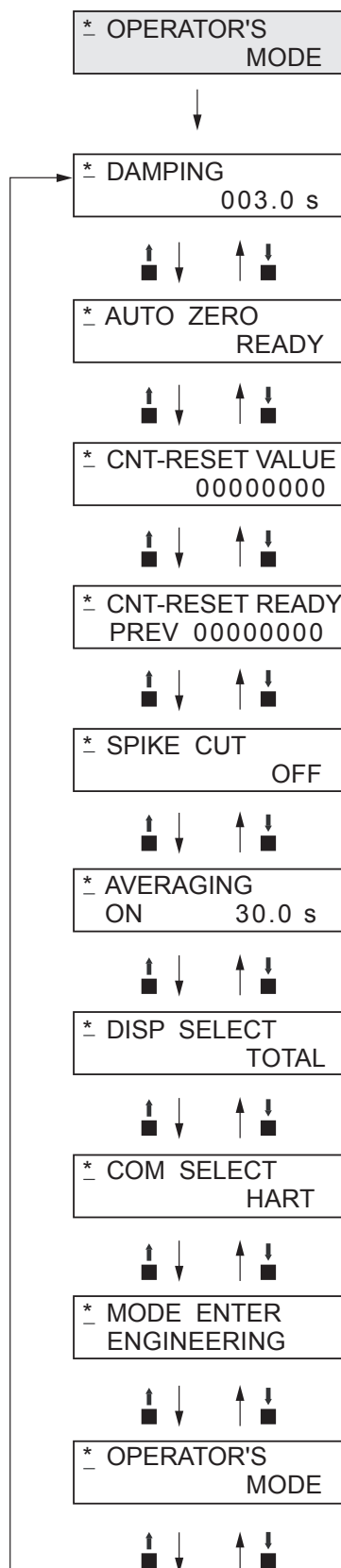

5-5-1 : Changing setting of damping time constant

Damping means a response time of the primary time lag (63.2% response) for a step response of the flow rate. If the out fluctuations are large, increase the damping. A large damping value stabilizes the output but lowers the response performance. We suggest setting the damping to the largest value the system can accept.

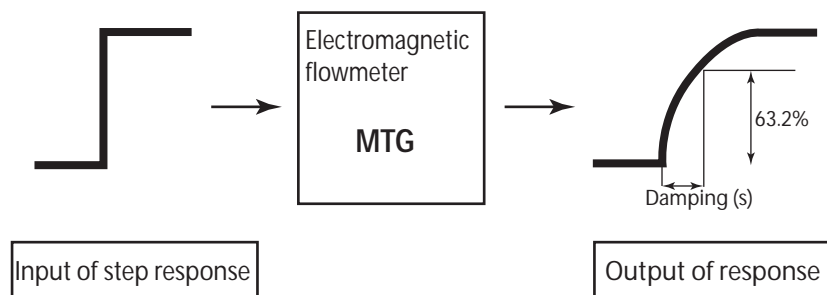

Figure 5-1 Damping output characteristics

Set the damping time constant in accordance with the following procedure:

Step	Procedure	Screen
1	The screen at right is a screen display example in MEASURING MODE (measurement state). Press the MODE key.	<pre> 20.0 % 01.94 m³/h WPO 00069401 </pre>
2	The OPERATOR'S MODE screen appears for approx. two seconds and then the damping setting screen appears.	<pre> 20.0 % * OPERATOR'S _ MODE </pre> <pre> 20.0 % * DAMPING _ 005.0 s </pre>
3	Press the → key until the cursor is at the value to be changed. In this example, the key is pressed three times to move to the position “5.”	<pre> * DAMPING 20.0 % 00<u>5</u>.0 s </pre>
4	Press the ↑ or ↓ key to display a time constant to be changed. In this example, the ↑ key is pressed five times to change the damping time from 5 seconds to 10 seconds.	<pre> * DAMPING 20.0 % 00<u>5</u>.0 s </pre>
5	Press the → key until the cursor is back at the mode indicator. Press the MODE key to return to the MEASURING MODE and to save data.	<pre> * DAMPING 20.0 % _ 005.0 s </pre>

⚠ CAUTION

You have only ten minutes to return to MEASURING MODE to save the new value before the system resets it to the previously saved value.

5-5-2 : Auto zero adjustment

Auto zero must be carried out only under the condition when the detector is filled with process fluid at zero flow. Run this function only after installing the electromagnetic flowmeter to the process pipe. Performing this function under a condition where the process fluid is not at zero flow may cause measurement errors.

Set range: None in particular

Default: None in particular

~Note *The zero adjustment takes approx. two minutes. During the zero adjustment, the output of analog current may rise to approx. 9 mA in some cases. This is not abnormal. To carry out the zero adjustment, set the control loop to manual.*

Make the auto zero adjustment in accordance with the following procedure:

Step	Procedure	Screen
1	The screen at right is a screen display example in MEASURING MODE (measurement state). Press the MODE key.	<div style="border: 1px solid black; padding: 5px; text-align: center;"> 1.0 % 01.94 m³/h 00069401 </div>
2	The OPERATOR'S MODE screen appears for approx. two seconds and then the damping setting screen appears.	<div style="border: 1px solid black; padding: 5px; text-align: center;"> 1.0 % * OPERATOR'S _ MODE </div> <div style="border: 1px solid black; padding: 5px; text-align: center;"> 1.0 % * DAMPING 005.0 s </div>
3	Press the ↑ key once to display the screen as shown.	<div style="border: 1px solid black; padding: 5px; text-align: center;"> 0.0 % * AUTO ZERO _ READY </div>
4	Press the → key to move the cursor to the position READY.	<div style="border: 1px solid black; padding: 5px; text-align: center;"> 0.0 % * AUTO ZERO _ READY </div>
5	Press the ↑ key to start the auto zero adjustment. If the main display selects % flowrate, the display of 0.0 blinks during adjustment. With the adjustment completed, the display stops blinking with ON switched to READY. This zero adjustment takes about two minutes.	<div style="border: 1px solid black; padding: 5px; text-align: center;"> 0.0 % * AUTO ZERO _ ON </div> <div style="border: 1px solid black; padding: 5px; text-align: center;"> 0.0 % * AUTO ZERO _ READY </div>
6	Press the → key to move the cursor to the position under *. Press the MODE key to return to the MEASURING MODE and save data.	<div style="border: 1px solid black; padding: 5px; text-align: center;"> 0.0 % * AUTO ZERO _ READY </div>

⚠ CAUTION

You have only ten minutes to return to MEASURING MODE to save the new value before the system resets it to the previously saved value.

5-5-3 : Setting of built-in counter reset value

Set a start value of the built-in counter. The scale of this value is considered as the weight of the pulse. Carry out the built-in counter reset in Section 5.4.5 to start totalization from any totalized value.

Set range: 00000000 - 99999999

Default: 00000000

Set an internal counter reset value in accordance with the following procedure:

Step	Procedure	Screen
1	The screen at the right is a screen display example in MEASURING MODE (measurement state). Press the MODE key.	<div style="border: 1px solid black; padding: 5px; width: fit-content;"> <div style="text-align: right;">20.0 %</div> <div style="text-align: right;">01.94 m³/h</div> <div style="display: flex; justify-content: space-between;"> WPO 00069401 </div> </div>
2	The OPERATOR'S MODE screen appears for approx. two seconds and then the damping setting screen appears.	<div style="border: 1px solid black; padding: 5px; width: fit-content;"> <div style="text-align: right;">20.0 %</div> <div style="text-align: center;">* OPERATOR'S _ MODE</div> </div> <div style="border: 1px solid black; padding: 5px; width: fit-content;"> <div style="text-align: right;">20.0 %</div> <div style="text-align: center;">* DAMPING _</div> <div style="text-align: right;">005.0 s</div> </div>
3	Press the ↑ key twice to display the screen.	<div style="border: 1px solid black; padding: 5px; width: fit-content;"> <div style="text-align: right;">20.0 %</div> <div style="text-align: center;">* CNT-RESET VALUE _</div> <div style="text-align: right;">00044444</div> </div>
4	Press the → key to move the cursor to the position under a target value to be changed.	<div style="border: 1px solid black; padding: 5px; width: fit-content;"> <div style="text-align: right;">20.0 %</div> <div style="text-align: center;">* CNT-RESET VALUE</div> <div style="text-align: right;">0000<u>0</u>000</div> </div>
5	Press the ↑ or ↓ key to set a desired value.	<div style="border: 1px solid black; padding: 5px; width: fit-content;"> <div style="text-align: right;">20.0 %</div> <div style="text-align: center;">* CNT-RESET VALUE</div> <div style="text-align: right;">0000<u>5</u>000</div> </div>
6	Press the → key to move the cursor to the position under *. Press the MDOE key to return to the MEASURING MODE and to save data.	<div style="border: 1px solid black; padding: 5px; width: fit-content;"> <div style="text-align: right;">20.0 %</div> <div style="text-align: center;">* CNT-RESET VALUE</div> <div style="text-align: right;">00005000</div> </div>

⚠ CAUTION

You have only ten minutes to return to MEASURING MODE to save the new value before the system resets it to the previously saved value.

5-5-4 : Setting of built-in counter reset value

Reset the built-in counter to start totalization from a value set as the built-in counter reset value. If this value is set to 1000, the built-in counter starts totalization from 1000 after the counter is completely reset.

If the built-in counter is reset, the built-in counter value just before the reset appears at the side of PREV on the LCD display.

Set range: None

Default: None

Reset the internal counter in accordance with the following procedure:

Step	Procedure	Screen
1	The screen at the right is a screen display example in MEASURING MODE (measurement state). Press the MODE key.	<div style="border: 1px solid black; padding: 5px; width: fit-content;"> <p style="text-align: right;">20.0 % 01.94 m³/h</p> <p>WPO 00069401</p> </div>
2	The OPERATOR'S MODE screen appears for approx. two seconds and then the damping setting screen appears.	<div style="border: 1px solid black; padding: 5px; width: fit-content;"> <p style="text-align: right;">20.0 % * _ OPERATOR'S MODE</p> </div> <div style="border: 1px solid black; padding: 5px; width: fit-content; margin-top: 10px;"> <p style="text-align: right;">20.0 % * _ DAMPING 005.0 s</p> </div>
3	Press the ↑ key three times to display the screen shown on the right.	<div style="border: 1px solid black; padding: 5px; width: fit-content;"> <p style="text-align: right;">20.0 % * _ CNT-RESET READY PREV 00000000</p> </div>
4	Press the → key to move the cursor to the position READY.	<div style="border: 1px solid black; padding: 5px; width: fit-content;"> <p style="text-align: right;">20.0 % * CNT-RESET <u>READY</u> PREV 00000000</p> </div>
5	Press the ↑ key to reset. In 0.5 seconds, the reset is completed with ON changing to READY.	<div style="border: 1px solid black; padding: 5px; width: fit-content;"> <p style="text-align: right;">20.0 % * CNT-RESET <u>ON</u> PREV 00000000</p> </div> <div style="border: 1px solid black; padding: 5px; width: fit-content; margin-top: 10px;"> <p style="text-align: right;">20.0 % * CNT-RESET READY PREV 00123456</p> </div>
6	Press the → key to move the cursor to the position under *. Press the MODE key to return to the MEASURING MODE and save data.	<div style="border: 1px solid black; padding: 5px; width: fit-content;"> <p style="text-align: right;">20.0 % * _ CNT-RESET READY PREV 00123456</p> </div>

⚠ CAUTION

You have only ten minutes to return to MEASURING MODE to save the new value before the system resets it to the previously saved value.

5-5-5 : Setting auto spike cut

This function eliminates steep noise spikes (spike noise) in the flow rate. Noise generated when foreign matters collide with electrode is an example of the spike noise.

When the flow rate changes sharply, this function holds the outputs according to the damping time. Generally the spike noise occurs in a few milliseconds and settles down within the output holding time and the outputs are not affected. For ordinary flowrate changes, the output responds after the damping hold time.

It is not recommended to use this function for applications requiring high response and performance, e.g., the function should not be used when a pump frequently generates pulsation.

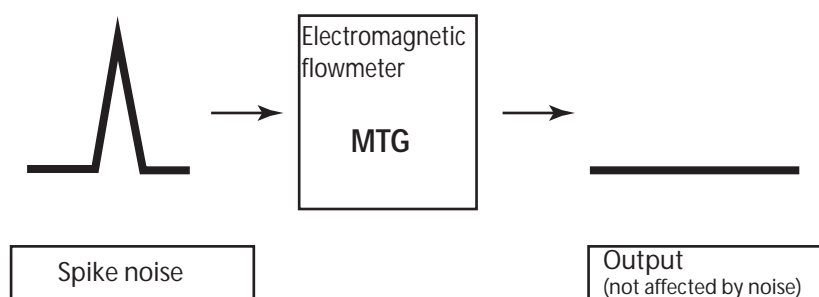

Figure 5-2 Auto spike cut output characteristics

Set the auto spike cut in accordance with the following procedure.

Step	Procedure	Screen
1	The screen at right is a screen display example in MEASURING MODE (measurement state). Press the MODE key.	<div style="border: 1px solid black; padding: 5px; width: fit-content;"> <div style="text-align: right;">20.0 %</div> <div style="text-align: right;">01.94 m³/h</div> <div style="text-align: left;">WPO 00069401</div> </div>
2	The OPERATOR'S MODE screen appears for approx. two seconds and then the damping setting screen appears.	<div style="border: 1px solid black; padding: 5px; width: fit-content;"> <div style="text-align: right;">20.0 %</div> <div style="text-align: left;">* OPERATOR'S MODE</div> </div> <div style="border: 1px solid black; padding: 5px; width: fit-content;"> <div style="text-align: right;">20.0 %</div> <div style="text-align: left;">* DAMPING 005.0 s</div> </div>
3	Press the ↑ key four times to display the screen shown on the right.	<div style="border: 1px solid black; padding: 5px; width: fit-content;"> <div style="text-align: right;">20.0 %</div> <div style="text-align: left;">* SPIKE CUT OFF</div> </div>
4	Press the → key to move the cursor to the OFF position.	<div style="border: 1px solid black; padding: 5px; width: fit-content;"> <div style="text-align: right;">20.0 %</div> <div style="text-align: left;">* SPIKE CUT OFF</div> </div>

Step	Procedure	Screen
5	Press the ↑ or ↓ key to select ON or OFF.	<div style="border: 1px solid black; padding: 5px; width: fit-content;"> <div style="text-align: right;">20.0 %</div> * SPIKE CUT <div style="text-align: right;">ON</div> </div>
6	Press the → key to move the cursor to the position under *. Press the MODE key to return to the MEASURING MODE and save data.	<div style="border: 1px solid black; padding: 5px; width: fit-content;"> <div style="text-align: right;">20.0 %</div> * SPIKE CUT <div style="text-align: right;">OFF</div> </div>

⚠ CAUTION

You have only ten minutes to return to MEASURING MODE to save the new value before the system resets it to the previously saved value.

5-5-6 : Setting moving average processing

This function is used to carry out the moving average processing of the measured flow rate values. The model MTG performs the flow rate calculation every 400 ms. For example, if the moving average process time is set to 2 seconds, the moving average processing will be carried out 2 sec./400 ms = 5 times.

If pulsation are generated, this function can be used to suppress the flow rate fluctuations. The moving average processing can be given by the following formula:

$$Q_{current} = \frac{\sum_{n=1}^k Q_k}{k}$$

Example) When the moving average processing is set to 2 sec.:

$$Q_{current} = \frac{q_k + Q_{k-1} + Q_{k-2} + Q_{k-3} + Q_{k-4}}{5}$$

where q_k is a value currently measured, and Q_k is a previous output value.

Set range: ON / OFF
 ON (1.0 to 30.0 s)
 Default: OFF

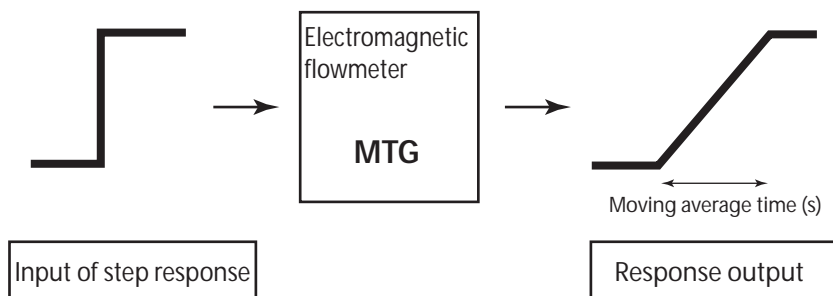

Figure 5-3 Output characteristics of moving average processing

Set the moving average processing in accordance with the following procedure:

Step	Procedure	Screen
1	The screen at right is a screen display example in MEASURING MODE (measurement state). Press the MODE key.	<div style="border: 1px solid black; padding: 5px; width: fit-content;"> 20.0 % 01.94 m³/h WPO 00069401 </div>
2	The OPERATOR'S MODE screen appears for approx. two seconds and then the damping setting screen appears.	<div style="border: 1px solid black; padding: 5px; width: fit-content;"> 20.0 % * _ OPERATOR'S MODE </div> <div style="border: 1px solid black; padding: 5px; width: fit-content;"> 20.0 % * _ DAMPING 005.0 s </div>
3	Press the ↑ or ↓ key to display the screen shown on the right.	<div style="border: 1px solid black; padding: 5px; width: fit-content;"> 20.0 % * _ AVERAGING OFF </div>
4	Press the → key to move the cursor to the OFF position.	<div style="border: 1px solid black; padding: 5px; width: fit-content;"> 20.0 % * AVERAGING OFF </div>
5	Press the ↑ key to switch the OFF screen to the ON screen. Press the → key to move the cursor to the value to be changed.	<div style="border: 1px solid black; padding: 5px; width: fit-content;"> 20.0 % * AVERAGING ON 01.0 s </div>
6	Press the ↑ or ↓ key to display a value to be set.	<div style="border: 1px solid black; padding: 5px; width: fit-content;"> 20.0 % * AVERAGING ON 05.0 s </div>
7	Press the → key to move the cursor back to the position under *. Press the MODE key to return to the MEASURING MODE and save data.	<div style="border: 1px solid black; padding: 5px; width: fit-content;"> 20.0 % * _ AVERAGING ON 05.0 s </div>

⚠ CAUTION

You have only ten minutes to return to MEASURING MODE to save the new value before the system resets it to the previously saved value.

5-5-7 : Setting empty pipe detection

Overview of empty pipe detection

The empty pipe detection function fixes analog output (4 to 20 mA) and pulse output to zero flow values when the detector is empty.

The display alternately shows zero value and "Empty Status".

Mechanism of empty pipe detection

Detect empty pipe condition by monitoring flow rate signal. Once the flow rate signal fluctuates over a certain threshold, the device judges that the detector is empty.

There are three threshold levels to meet an environment where the device is installed.

Set an appropriate threshold level from below.

SENSITIVITY HIGH

SENSITIVITY MID

SENSITIVITY LOW

Outputs

Analog output (4 to 20 mA): Fixes to 0% (4 mA)

Pulse output: Fixes to 0 (does not generate pulses)

Display: Flashes the messages "0%" and "EMPTY STATUS" alternately (when % flow rate is specified for the main display)

Flashes the messages "0.000 RATE" and "EMPTY STATUS" alternately (when actual flow rate is specified for the main display)

Flashes the messages "XXXXXXXX" (totalized value at setup) and "EMPTY STATUS" alternately (when totalized value is specified for the main display)

Operation conditions

- The grounding work must be securely carried out (grounding resistance 100Ω or less).
- The fluid conductivity must be 30 μS/cm or greater.
- The noise level must be higher than or equal to the set threshold value when the pipe is empty.
- The noise level must be lower than or equal to the set threshold value when the pipe is filled with fluid.

Default

SENSITIVITY OFF

Setting parameters

Table 5-1 Set levels for empty pipe detection

Empty pipe detection sensitivity	Noise detection level
SENSITIVITY OFF	Empty pipe detection function OFF
SENSITIVITY HIGH	Signal level Threshold LOW
SENSITIVITY MID	Signal level Threshold MID
SENSITIVITY LOW	Signal level Threshold HIGH

~Note 1 *This function is only available for detectors with a bore diameter of 10 mm or more. When the diameter is 2.5 mm or 5 mm, the setting screen for this function appears in the converter's display, but is not applicable.*

~Note 2 *This function is applicable for the converters with ROM version 3.8 or higher. If it is 3.7 or lower, the setting screen for this function is not displayed. To check the ROM version, refer to 5.7.7 "Displaying ROM version and date".
To use the empty pipe detection function with the ROM version 3.7 or lower, the main board must be replaced. For details, contact our sales representative.*

Set the empty pipe detection function in accordance with the following procedure.

Step	Procedure	Screen
1	The screen at right is a screen display example in MEASURING MODE (measurement state).	<div style="border: 1px solid black; padding: 5px; width: fit-content;"> <p style="text-align: right;">20.0 %</p> <p style="text-align: right;">01.94 m³/h</p> <p>WPO 00069401</p> </div>
2	Press the MODE key. The OPERATOR'S MODE screen appears for approx. two seconds, and then the damping setting screen appears.	<div style="border: 1px solid black; padding: 5px; width: fit-content;"> <p style="text-align: right;">20.0 %</p> <p>* OPERATOR'S MODE</p> </div> <div style="border: 1px solid black; padding: 5px; width: fit-content; margin-top: 5px;"> <p style="text-align: right;">20.0 %</p> <p>* DAMPING 005.0 s</p> </div>
3	Press the ↑ key to display the screen shown on the right.	<div style="border: 1px solid black; padding: 5px; width: fit-content;"> <p style="text-align: right;">20.0 %</p> <p>* EMPTY SENSITIVITY OFF</p> </div>
4	Press the → key to move the cursor to the OFF position.	<div style="border: 1px solid black; padding: 5px; width: fit-content;"> <p style="text-align: right;">20.0 %</p> <p>* EMPTY SENSITIVITY <u>OFF</u></p> </div>
5	Press the ↑ key to select SENSITIVITY HIGH.	<div style="border: 1px solid black; padding: 5px; width: fit-content;"> <p style="text-align: right;">20.0 %</p> <p>* EMPTY SENSITIVITY <u>HIGH</u></p> </div>
6	Press the → key to move the cursor to the position under *. Press the MODE key to return to the MEASURING MODE, and save the data.	<div style="border: 1px solid black; padding: 5px; width: fit-content;"> <p style="text-align: right;">20.0 %</p> <p>* EMPTY SENSITIVITY HIGH</p> </div>
7	<p>Empty the pipe with SENSITIVITY HIGH set to check if the function detects the empty status. Perform the checking when 30 seconds or more have passed, because it takes at least 30 seconds to detect the empty status after the pipe becomes empty.</p> <p>(Result) When the empty status is detected, the screen at right appears. The "EMPTY STATUS" message is flashing, the analog output is fixed to 4 mA, and the pulse output stops.</p>	<div style="border: 1px solid black; padding: 5px; width: fit-content;"> <p style="text-align: right;">0.0 %</p> <p>EMPTY STATUS</p> </div>

(To the next page)

Step	Procedure	Screen																				
8	<p>Repeat steps 1 to 5 to set SENSITIVITY MID or SENSITIVITY LOW to check if the function also detects the empty status with the converter's display.</p> <p>Depending on whether the empty status is detected in each setting, the result falls into one of the following.</p> <p>(Results of empty pipe detection operation check in empty status)</p> <table border="1" data-bbox="528 584 1425 763"> <thead> <tr> <th>Setting</th> <th>Results (1)</th> <th>Results (2)</th> <th>Results (3)</th> <th>Results (4)</th> </tr> </thead> <tbody> <tr> <td>LOW</td> <td>EMPTY STATUS flashes</td> <td>EMPTY STATUS does not flash</td> <td>EMPTY STATUS does not flash</td> <td>EMPTY STATUS does not flash</td> </tr> <tr> <td>MID</td> <td>EMPTY STATUS flashes</td> <td>EMPTY STATUS flashes</td> <td>EMPTY STATUS does not flash</td> <td>EMPTY STATUS does not flash</td> </tr> <tr> <td>HIGH</td> <td>EMPTY STATUS flashes</td> <td>EMPTY STATUS flashes</td> <td>EMPTY STATUS flashes</td> <td>EMPTY STATUS does not flash</td> </tr> </tbody> </table> <ul style="list-style-type: none"> • If the empty status is not detected when HIGH has been set (in the case of result (4)), this function is not available in that installation environment. <p>Repeat steps 1 to 5 to set the function to OFF.</p>	Setting	Results (1)	Results (2)	Results (3)	Results (4)	LOW	EMPTY STATUS flashes	EMPTY STATUS does not flash	EMPTY STATUS does not flash	EMPTY STATUS does not flash	MID	EMPTY STATUS flashes	EMPTY STATUS flashes	EMPTY STATUS does not flash	EMPTY STATUS does not flash	HIGH	EMPTY STATUS flashes	EMPTY STATUS flashes	EMPTY STATUS flashes	EMPTY STATUS does not flash	
Setting	Results (1)	Results (2)	Results (3)	Results (4)																		
LOW	EMPTY STATUS flashes	EMPTY STATUS does not flash	EMPTY STATUS does not flash	EMPTY STATUS does not flash																		
MID	EMPTY STATUS flashes	EMPTY STATUS flashes	EMPTY STATUS does not flash	EMPTY STATUS does not flash																		
HIGH	EMPTY STATUS flashes	EMPTY STATUS flashes	EMPTY STATUS flashes	EMPTY STATUS does not flash																		
9	<p>Next, fill fluid into the pipe.</p> <p>Check that the empty status is not detected in this condition.</p> <p>Since it takes at least 30 seconds to clear the empty status after fluid is filled in the pipe, perform checking when 30 seconds or more have passed after fluid is filled.</p> <p>(Branch 1)</p> <ul style="list-style-type: none"> • When the result is (1) in step 8 Check that the empty status is not detected when SENSITIVITY LOW has been set. <p>(Result)</p> <ul style="list-style-type: none"> • If the empty status is not detected, use that SENSITIVITY LOW setting without change. • If the empty status is detected and the screen shown on the right appears, this function is not available in that environment. Set the function to OFF. 	<div style="border: 1px solid black; padding: 5px; width: fit-content;"> <table style="width: 100%; border-collapse: collapse;"> <tr> <td style="width: 80%;"></td> <td style="text-align: right;">0.0 %</td> </tr> <tr> <td>EMPTY</td> <td style="text-align: right;">STATUS</td> </tr> </table> </div>		0.0 %	EMPTY	STATUS																
	0.0 %																					
EMPTY	STATUS																					

(To the next page)

Step	Procedure	Screen
<p>9 (Continued)</p>	<p>(Branch 2)</p> <ul style="list-style-type: none"> When the result is (2) in step 8 Check that the empty status is not detected when SENSITIVITY MID has been set. <p>(Result)</p> <ul style="list-style-type: none"> If the empty status is not detected, use that SENSITIVITY MID setting without change. If the empty status is detected and the screen shown on the right appears, this function is not available in that environment. Set the function to OFF. <p>(Branch 3)</p> <ul style="list-style-type: none"> When the result is (3) in step 8 Check that the empty status is not detected when SENSITIVITY HIGH has been set. <p>(Result)</p> <ul style="list-style-type: none"> If the empty status is not detected, use that SENSITIVITY HIGH setting without change. If the empty status is detected and the screen shown on the right appears, this function is not available in that environment. Set the function to OFF. 	<div data-bbox="1067 602 1358 707" style="border: 1px solid black; padding: 5px; margin-bottom: 20px;"> <p style="text-align: right;">0.0 %</p> <p>EMPTY STATUS</p> </div> <div data-bbox="1067 1102 1358 1207" style="border: 1px solid black; padding: 5px;"> <p style="text-align: right;">0.0 %</p> <p>EMPTY STATUS</p> </div>

Empty pipe detection flow chart

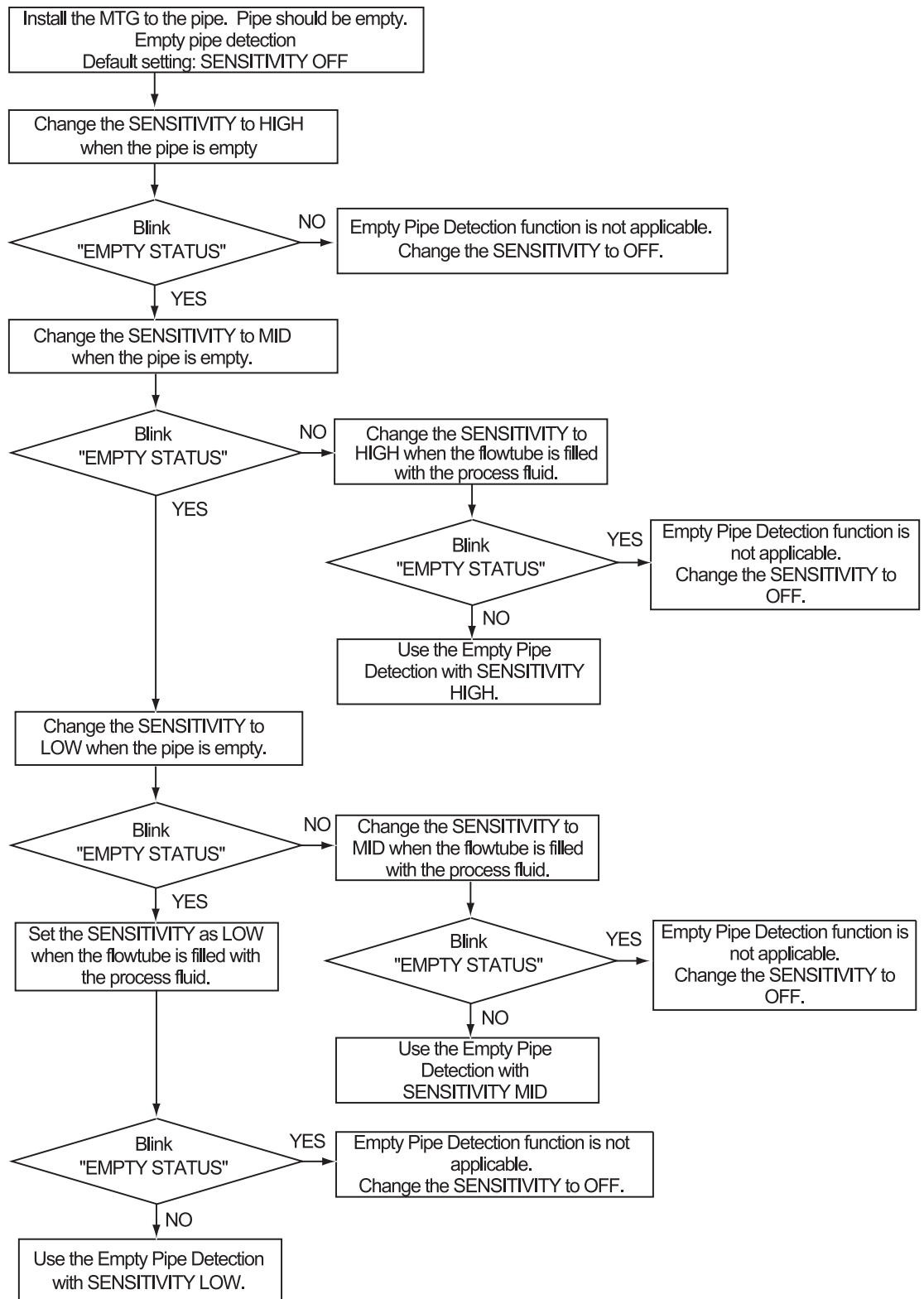

Empty pipe detection troubleshooting

Troubleshooting

If a problem occurs during empty pipe detection, take appropriate actions in accordance with the following procedure.

Trouble	Check point and troubleshooting
<ul style="list-style-type: none"> Empty pipe detection mistake when fluid is filled because the unit is used in the place where the flow rate changes swiftly. 	<p>When the flow rate swiftly changes due to pulsations from the pump, the function may recognize some of the swinging flow rate signals as those in the empty status and mistakenly determine it as empty. In this case, it is recommended to install the unit in the place where no effects from the pulsation can be reached, e.g., by securing a longer upstream straight pipe section. When the unit is installed in a place where swift change of the flow rate may cause misdetection of the empty status when fluid is filled, set this function to OFF. Please note that increasing the damping time constant does not solve this problem because this function determines the empty status based on the signals before the damping process.</p>
<ul style="list-style-type: none"> Empty not detected when the pipe is empty. 	<p>If there is conductivity between electrodes or between the electrode and grounding ring due to the fluid left in the pipe, etc., the empty status may not be detected even when the pipe is empty. In this case, this function is not available. Set it to OFF.</p> <p>If the display and output are not always fixed to zero because, for example, the fluid drops on the electrode, they may become stable at zero by increasing the setting value for low flow cutoff and setting the auto spike cut to ON.</p>
<ul style="list-style-type: none"> Empty pipe detection operation error after the surrounding noise environment has been changed by expansion of equipment etc., such as changing the installation location or installing the high-current motors or pumps. 	<p>Since change of the environment also changes the noise volume, the empty pipe detection may not function correctly with the conventional threshold value for it. In this case, reset the threshold value.</p>
<ul style="list-style-type: none"> Empty detected with flowing fluid in fluid-filled status (empty not detected with stationary fluid). 	<p>The empty status may be detected even when the fluid is filled because of the effects of the flow noises generated from the flowing fluid. In this case, reset the threshold value so that the empty status is not mistakenly detected when the fluid is flowing.</p>

5-5-8 : Selecting flow rate to be displayed in the main display

Select the flow rate to be always shown in the main display. The flow rates other than that selected for the main display are shown in the sub displays. Thereby, three flow rates can always be monitored.

Set	Description
%	% flow rate
RATE	Actual flow rate
TOTAL	Totalized value

% (% flow rate): Displays % flow rate

RATE (Actual flow rate)

Setting range: %, RATE, TOTAL

Default: RATE

Select the flow rate to be shown in the main display in accordance with the following procedure:

Step	Procedure	Screen
1	The screen at right is a screen display example in MEASURING MODE (measurement state). Press the MODE key.	<div style="border: 1px solid black; padding: 5px; text-align: right;"> 20.0 % 01.94 m³/h WPO 00069401 </div>
2	The OPERATOR'S MODE screen appears for approx. two seconds and then the damping setting screen appears.	<div style="border: 1px solid black; padding: 5px; text-align: right;"> 20.0 % * _ OPERATOR'S MODE </div> <div style="border: 1px solid black; padding: 5px; text-align: right;"> 20.0 % * _ DAMPING 005.0 s </div>
3	Press the ↑ or ↓ key to display the screen as shown on the right.	<div style="border: 1px solid black; padding: 5px; text-align: right;"> 20.0 % * _ DISP SELECT % </div>
4	Press the → key to move the cursor to the position for the flow rate display method (% , RATE, TOTAL). The screen at right shows an example where % flow rate has been set for the main display.	<div style="border: 1px solid black; padding: 5px; text-align: right;"> 20.0 % * _ OPERATOR'S MODE </div>
5	Press the ↑ or ↓ key to select a flow rate display to be set. The screen at right shows an example where RATE (actual flow rate) display has been selected.	<div style="border: 1px solid black; padding: 5px; text-align: right;"> 0.30 RATE * _ DISP SELECT RATE </div>
6	Press the → key to move the cursor to the position under *. Press the MODE key to return to the MEASURING MODE and to change to the set flow rate display.	<div style="border: 1px solid black; padding: 5px; text-align: right;"> 0.30 RATE * _ DISP SELECT RATE </div>

CAUTION

You have only ten minutes to return to MEASURING MODE to save the new value before the system resets it to the previously saved value.

5-5-9 : Selecting a communication system

Select the communication system (SFC, DE, HART, and communication disable).

Select a communication system to be used. Note that the converter will be rebooted when the MODE key is pressed to switch to the MEASURING MODE after the settings are changed.

HART: HART communication by using the HART Communicator.

SFN.A: SFC in the analog (4-20 mA) output mode.

SFN.D: DE (Digital Enhanced) communication.

NONE: Communication is not used/disable.

By default, SFN.A: SFC communication is set.

Select a communication system in accordance with the following procedure:

Step	Procedure	Screen
1	The screen at right is a screen display example in MEASURING MODE (measurement state). Press the MODE key.	<div style="border: 1px solid black; padding: 5px; width: fit-content;"> <div style="text-align: right;">20.0 %</div> <div style="text-align: right;">01.94 m³/h</div> <div style="display: flex; justify-content: space-between;"> WPO 00069401 </div> </div>
2	The OPERATOR'S MODE screen appears for approx. two seconds and then the damping setting screen appears.	<div style="border: 1px solid black; padding: 5px; width: fit-content;"> <div style="text-align: right;">20.0 %</div> <div style="text-align: center;">* OPERATOR'S _ MODE</div> </div> <div style="border: 1px solid black; padding: 5px; width: fit-content;"> <div style="text-align: right;">20.0 %</div> <div style="text-align: center;">* DAMPING _ 005.0 s</div> </div>
3	Press the ↑ key three times to display the screen as shown on the right.	<div style="border: 1px solid black; padding: 5px; width: fit-content;"> <div style="text-align: right;">20.0 %</div> <div style="text-align: center;">* COM SELECT _ SFN. A</div> </div>
4	Press the → key to move the cursor to the position for the communication system (SFN.A, SFN.D, NONE, HART). The screen at right shows an example where SFN.A has been selected for the communication system.	<div style="border: 1px solid black; padding: 5px; width: fit-content;"> <div style="text-align: right;">20.0 %</div> <div style="text-align: center;">* COM SELECT _ SFN. A</div> </div>
5	Press the ↑ or ↓ key to select a desired communication system to be set. The screen at right shows an example where HART communication has been selected.	<div style="border: 1px solid black; padding: 5px; width: fit-content;"> <div style="text-align: right;">20.0 %</div> <div style="text-align: center;">* COM SELECT _ HART</div> </div>

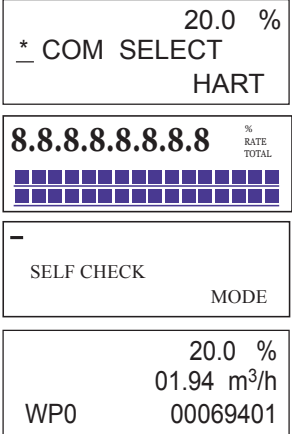
Step	Procedure	Screen
6	Press the → key to move the cursor to the position under *. Pressing the MODE key reboots the converter, returns to MEASURING MODE, and the communication system changes and saved.	 <p>The screenshots show the following information:</p> <ul style="list-style-type: none"> Top screen: 20.0 %, * COM SELECT, HART Second screen: 8.8.8.8.8.8.8.8, % RATE TOTAL, a bar graph, and a grid of 20 small squares. Third screen: SELF CHECK, MODE Bottom screen: 20.0 %, 01.94 m³/h, WPO, 00069401

⚠ CAUTION

You have only ten minutes to return to MEASURING MODE to save the new value before the system resets it to the previously saved value.

5-5-10 : Entering ENGINEERING MODE and MAINTENANCE MODE

Introduction

This section describes how to enter ENGINEERING MODE, in which setup parameters for the electromagnetic flowmeter are to be configured, and MAINTENANCE MODE, in which calibration and check are to be carried out.

~Note *The mode selection screen may not appear, depending on the settings of write protect. Operate the write protect switch on the main board, and then select one from levels 1, 2 and 3 to display the screen for selecting ENGINEERING MODE only. Select write protect level 0 to display the screen for selecting both ENGINEERING MODE and MAINTENANCE MODE. See “5-3-2 : Display of write protect level”.*

The procedure for entering ENGINEERING MODE is shown below.

Step	Procedure	Screen
1	The screen shown right is a screen display example in MEASURING MODE (measurement state). Press the MODE key.	<div style="border: 1px solid black; padding: 5px; width: fit-content;"> <p style="text-align: right;">20.0 %</p> <p style="text-align: right;">01.94 m³/h</p> <p>WP0 00069401</p> </div>
2	The OPERATOR'S MODE screen appears for approx. two seconds and then the damping setting screen appears.	<div style="border: 1px solid black; padding: 5px; width: fit-content;"> <p style="text-align: right;">20.0 %</p> <p>* OPERATOR'S</p> <p style="text-align: right;">MODE</p> </div> <div style="border: 1px solid black; padding: 5px; width: fit-content;"> <p style="text-align: right;">20.0 %</p> <p>* DAMPING</p> <p style="text-align: right;">005.0 s</p> </div>
3	Press the ↑ key twice to display the screen as shown.	<div style="border: 1px solid black; padding: 5px; width: fit-content;"> <p style="text-align: right;">20.0 %</p> <p>* MODE ENTER</p> <p style="text-align: right;">ENGINEERING</p> </div>
4	Press the → key once to move the cursor to the position shown on the screen.	<div style="border: 1px solid black; padding: 5px; width: fit-content;"> <p style="text-align: right;">20.0 %</p> <p>* MODE ENTER</p> <p style="text-align: right;">ENGINEERING</p> </div>
5	Press the ↑ key. With the display is changed, ENGINEERING MODE is active. The screen appears in approx. two seconds.	<div style="border: 1px solid black; padding: 5px; width: fit-content;"> <p style="text-align: right;">20.0 %</p> <p># ENGINEERING</p> <p style="text-align: right;">MODE</p> </div> <div style="border: 1px solid black; padding: 5px; width: fit-content;"> <p style="text-align: right;">20.0 %</p> <p># ID SET</p> <p style="text-align: right;">XXXXXXXX</p> </div>

The procedure for entering MAINTENANCE MODE is shown below.

Step	Procedure	Screen
1	The screen shown on the right is a screen display example in MEASURING MODE (measurement state). Press the MODE key.	<div style="border: 1px solid black; padding: 5px; width: fit-content;"> <div style="text-align: right;">20.0 %</div> <div style="text-align: right;">01.94 m³/h</div> <div>WP0 00069401</div> </div>
2	The OPERATOR'S MODE screen appears for approx. two seconds and then the damping setting screen appears.	<div style="border: 1px solid black; padding: 5px; width: fit-content;"> <div style="text-align: right;">20.0 %</div> <div>* OPERATOR'S</div> <div style="text-align: right;">MODE</div> </div> <div style="border: 1px solid black; padding: 5px; width: fit-content;"> <div style="text-align: right;">20.0 %</div> <div>* DAMPING</div> <div style="text-align: right;">005.0 s</div> </div>
3	Press the ↑ key once to display the screen as shown on the right.	<div style="border: 1px solid black; padding: 5px; width: fit-content;"> <div style="text-align: right;">20.0 %</div> <div>* MODE ENTER</div> <div style="text-align: right;">MAINTENANCE</div> </div>
4	Press the → key once to move the cursor to the position shown on the screen.	<div style="border: 1px solid black; padding: 5px; width: fit-content;"> <div style="text-align: right;">20.0 %</div> <div>* MODE ENTER</div> <div style="text-align: right;">MAINTENANCE</div> </div>
5	Press the ↑ key. With the display changed, MAINTENANCE MODE is active. The screen appears in approx. two seconds.	<div style="border: 1px solid black; padding: 5px; width: fit-content;"> <div style="text-align: right;">20.0 %</div> <div>≥ MAINTENANCE</div> <div style="text-align: right;">MODE</div> </div> <div style="border: 1px solid black; padding: 5px; width: fit-content;"> <div style="text-align: right;">20.0 %</div> <div>≥ OUTPUT CHECK</div> <div style="text-align: right;">MODE OFF</div> </div>

5-6 : Configuration of ENGINEERING MODE

Introduction

ENGINEERING MODE has the following setting and adjustment items:

For details on items, see “5-6-1 : Setting ID” to “5-6-14 : Setting contact output status”.

Item	Contents	Screen
ID SET	Sets ID and TAG No.	<div style="border: 1px solid black; padding: 5px; width: fit-content;"> <div style="text-align: right;">20.0 %</div> # ID SET XXXXXXXXXX </div>
FUNC SET	Setting of open collector output, selects pulse output or contact output.	<div style="border: 1px solid black; padding: 5px; width: fit-content;"> <div style="text-align: right;">20.0 %</div> # FUNC SET PULSE </div>
EX, TYPE, DIA	Sets the detector information (Ex value, detector type, and bore diameter).	<div style="border: 1px solid black; padding: 5px; width: fit-content;"> <div style="text-align: right;">20.0 %</div> # EX 300.0 MTG DIA 200 </div>
SPAN	Sets the flow rate range.	<div style="border: 1px solid black; padding: 5px; width: fit-content;"> <div style="text-align: right;">20.0 %</div> # 1.0000 m/s SPAN 7.0690 m³/h </div>
GRAVITY	Sets the specific gravity when mass flow rate unit is selected.	<div style="border: 1px solid black; padding: 5px; width: fit-content;"> <div style="text-align: right;">20.0 %</div> # GRAVITY 1.0000 </div>
COEFFICIENT	Sets a compensation coefficient for flow rate calculation.	<div style="border: 1px solid black; padding: 5px; width: fit-content;"> <div style="text-align: right;">20.0 %</div> # COEFFICIENT 1.0000 </div>
PLS SCL	Sets flow rate (pulse scale) per pulse.	<div style="border: 1px solid black; padding: 5px; width: fit-content;"> <div style="text-align: right;">20.0 %</div> # PLS 10.000 Hz SCL 200.00 I/P </div>
PLS WID	Sets the output pulse width.	<div style="border: 1px solid black; padding: 5px; width: fit-content;"> <div style="text-align: right;">20.0 %</div> # PLS 10.000 Hz WID 0010 ms </div>

Item	Contents	Screen
DROP OUT	Sets drop out.	<div style="border: 1px solid black; padding: 5px; width: fit-content;"> <div style="text-align: right;">20.0 %</div> # DROPOUT <div style="text-align: right;">10 %</div> </div>
LOW FLOW CUT	Sets low flow cut.	<div style="border: 1px solid black; padding: 5px; width: fit-content;"> <div style="text-align: right;">20.0 %</div> # LOW FLOW CUT <div style="text-align: right;">10 %</div> </div>
HI-ALM/LOW-ALM	Sets upper/lower limit alarm.	<div style="border: 1px solid black; padding: 5px; width: fit-content;"> <div style="text-align: right;">20.0 %</div> # HI-AIM 100 % LO-AIM 0 % </div>
ERROR OUT MODE I. OUT	Determines the analog output failsafe direction.	<div style="border: 1px solid black; padding: 5px; width: fit-content;"> <div style="text-align: right;">20.0 %</div> # ERROR OUT MODE I.OUT HOLD </div>
ERROR OUT MODE P. OUT	Determines the pulse output failsafe direction.	<div style="border: 1px solid black; padding: 5px; width: fit-content;"> <div style="text-align: right;">20.0 %</div> # ERROR OUT MODE P.OUT HOLD </div>
ST. OUT MODE	Sets a contact output status.	<div style="border: 1px solid black; padding: 5px; width: fit-content;"> <div style="text-align: right;">20.0 %</div> # ST. OUTMODE NORMAL CLOSE </div>

~Note *After the MODE key is pressed, configured data in the ENGINEERING MODE are saved in non-volatile memory. When configure data, be sure to press the MODE key to save the data.*

LCD display flow

The ENGINEERING MODE display flow is as follows:

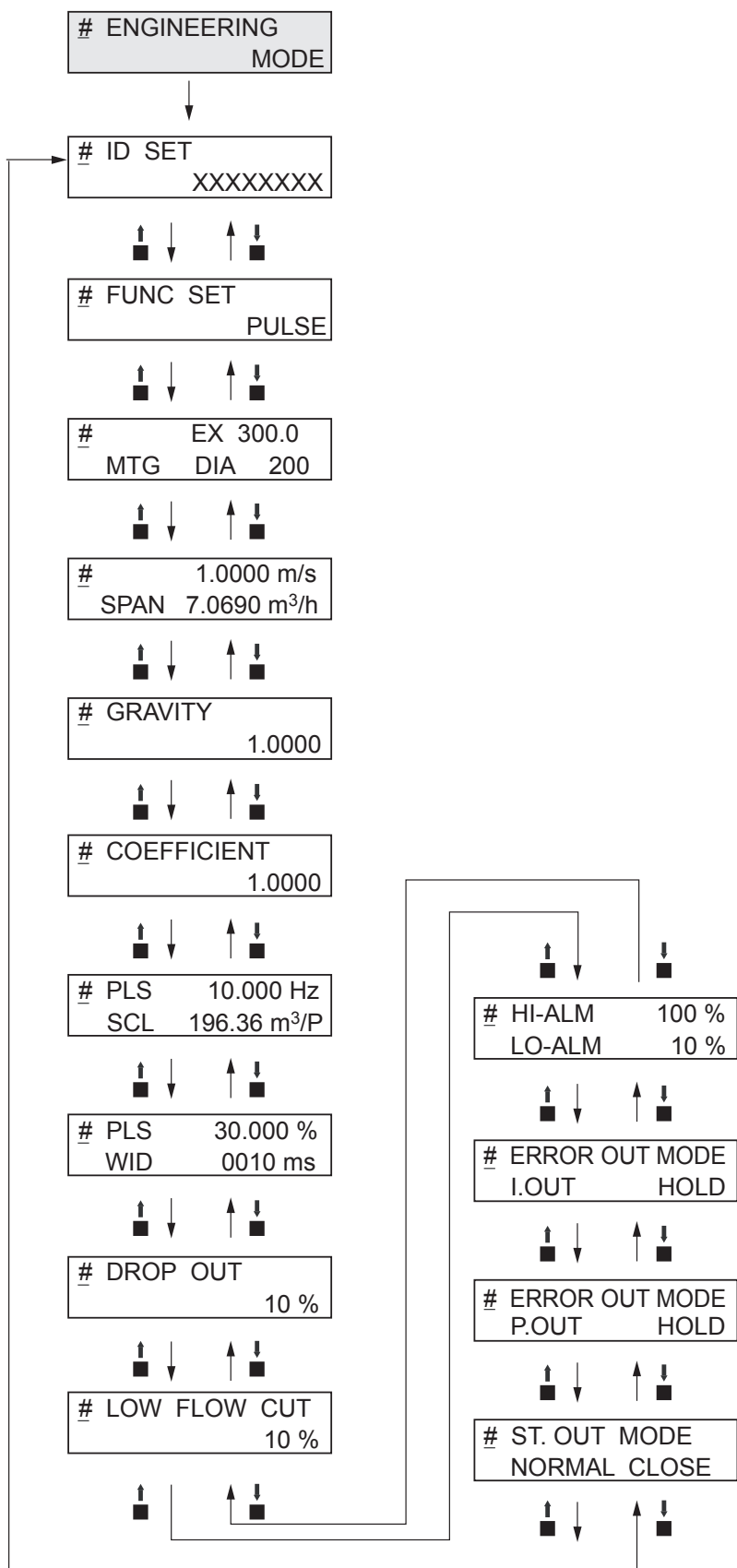

5-6-1 : Setting ID

You can enter a unique 8-digit alphanumeric code for the flowmeter.

Up to eight alphanumeric characters using any combination of letters (A to Z), numbers (0 to 9), - (dash), / (slash), space and period.

Set an ID in accordance with the following procedure:

Step	Procedure	Screen
1	Enter ENGINEERING MODE (see section 5-5-9 on page 5-30) and display the screen where the ID is to be set.	<div style="border: 1px solid black; padding: 5px; width: fit-content;"> <div style="text-align: right;">12.3 %</div> # ID SET XXXXXXXXXX </div>
2	Press the → key to move the cursor to the position under a desired character to be changed.	<div style="border: 1px solid black; padding: 5px; width: fit-content;"> <div style="text-align: right;">12.3 %</div> # ID SET XXXXXXXXXX </div>
3	Press the ↑ or ↓ key to select a desired character.	<div style="border: 1px solid black; padding: 5px; width: fit-content;"> <div style="text-align: right;">12.3 %</div> # ID SET FXXXXXXXXX </div>
4	If a target TAG NO. has been set, press the → key to move the cursor to the position under #. Press the MODE key to return to MEASURING MODE and to save data.	<div style="border: 1px solid black; padding: 5px; width: fit-content;"> <div style="text-align: right;">12.3 %</div> # ID SET FIC-0001 </div>

5-6-2 : Selecting pulse output or contact output

Pulse output or contact output are selectable. Both of them are open collector outputs.

When pulse output has been selected:

Set pulse scale, pulse width, drop out, and burn out.

When contact output has been selected:

As a contact output, self diagnosis output (critical failure) or upper/lower limit alarm is output.

Select % flow rate value for upper/lower alarm or output status (OPEN or CLOSE in normal (normal state)).

Setting range: PULSE: Selection of pulse output

STOUT: Selection of contact output

Default: PULSE

Select pulse output or contact output in accordance with the following procedure:

Step	Procedure	Screen
1	Enter ENGINEERING MODE in accordance with the entry into ENGINEERING MODE (see section 5-5-9 on page 5-30). Then press the ↑ or ↓ key to display the screen at right.	<div style="border: 1px solid black; padding: 5px; width: fit-content;"> <div style="text-align: right;">20.0 %</div> <div># FUNCSET</div> <div style="text-align: right;">PULSE</div> </div>
2	Press the → key to move the cursor to the position for set function. Press the ↑ or ↓ key to display a function to be set. Select either PULSE (pulse output) or STOUT (contact output).	<div style="border: 1px solid black; padding: 5px; width: fit-content;"> <div style="text-align: right;">20.0 %</div> <div># FUNCSET</div> <div style="text-align: right;"><u>P</u>LSE</div> </div> <div style="border: 1px solid black; padding: 5px; width: fit-content;"> <div style="text-align: right;">20.0 %</div> <div># FUNCSET</div> <div style="text-align: right;"><u>S</u>TOUT</div> </div>
3	Press the MODE key to return to the MEASURING MODE and to save data.	<div style="border: 1px solid black; padding: 5px; width: fit-content;"> <div style="text-align: right;">20.0 %</div> <div># FUNCSET</div> <div style="text-align: right;">STOUT</div> </div>

⚠ CAUTION

You have only ten minutes to return to MEASURING MODE to save the new value before the system resets it to the previously saved value.

5-6-3 : Setting detector information

Set detector information necessary for combination with the converter.

- EX value:** Each detector has a unique calibration factor (EX value). This value is determined at shipment in accordance with the actual flow rate calibration. DO NOT change this value or the flowmeter output will be incorrect.
- Detector type:** When measuring the flow rate, select MTG for the detector type. To perform adjustments and loop checks, select TST for the detector type.
- Bore diameter:** Sets the bore diameter (inside diameter) of the detector. The correct bore diameter is set as factory default setting.
- Setting range:** Detector constant: 200.0 to 699.9
Detector type: MTG/TST
Bore diameter: 2.5 to 200

Set the detector information in accordance with the following procedure:

Step	Procedure	Screen									
1	Enter ENGINEERING MODE in accordance with the entry into ENGINEERING MODE (see section 5-5-9 on page 5-30). Then press the ↑ or ↓ key to display the screen at right.	<table border="1"> <tr> <td></td> <td></td> <td>12.3 %</td> </tr> <tr> <td>#</td> <td>EX</td> <td>300.0</td> </tr> <tr> <td>MTG</td> <td>DIA</td> <td>050.0</td> </tr> </table>			12.3 %	#	EX	300.0	MTG	DIA	050.0
		12.3 %									
#	EX	300.0									
MTG	DIA	050.0									
2	Press the → key to set the detector constant. Using the ↑ or ↓ key, enter the numeric value found in the EX column stamped on the nameplate of the detector to be combined.	<table border="1"> <tr> <td></td> <td></td> <td>12.3 %</td> </tr> <tr> <td>#</td> <td>EX</td> <td>3<u>20</u>.0</td> </tr> <tr> <td>MTG</td> <td>DIA</td> <td>050.0</td> </tr> </table>			12.3 %	#	EX	3 <u>20</u> .0	MTG	DIA	050.0
		12.3 %									
#	EX	3 <u>20</u> .0									
MTG	DIA	050.0									
3	In addition, press the → key to select the detector type. Using the ↑ or ↓ key, select the detector type. To measure the flow rate, select MTG. To perform adjustments and loop checks, select TST.	<table border="1"> <tr> <td></td> <td></td> <td>12.3 %</td> </tr> <tr> <td>#</td> <td>EX</td> <td>320.0</td> </tr> <tr> <td><u>MTG</u></td> <td>DIA</td> <td>050.0</td> </tr> </table>			12.3 %	#	EX	320.0	<u>MTG</u>	DIA	050.0
		12.3 %									
#	EX	320.0									
<u>MTG</u>	DIA	050.0									
4	Then press the → key to select the bore diameter. Using the ↑ or ↓ key, select the bore diameter of the detector.	<table border="1"> <tr> <td></td> <td></td> <td>12.3 %</td> </tr> <tr> <td>#</td> <td>EX</td> <td>320.0</td> </tr> <tr> <td>MTG</td> <td>DIA</td> <td>100.<u>0</u></td> </tr> </table>			12.3 %	#	EX	320.0	MTG	DIA	100. <u>0</u>
		12.3 %									
#	EX	320.0									
MTG	DIA	100. <u>0</u>									
5	Using the → key, move the cursor to the position under #. Press the MODE key to return to the MEASURING MODE and save data.	<table border="1"> <tr> <td></td> <td></td> <td>12.3 %</td> </tr> <tr> <td><u>#</u></td> <td>EX</td> <td>320.0</td> </tr> <tr> <td>MTG</td> <td>DIA</td> <td>100.0</td> </tr> </table>			12.3 %	<u>#</u>	EX	320.0	MTG	DIA	100.0
		12.3 %									
<u>#</u>	EX	320.0									
MTG	DIA	100.0									

CAUTION

You have only ten minutes to return to MEASURING MODE to save the new value before the system resets it to the previously saved value.

5-6-4 : Setting flow rate range

Set the flow rate range. The lower limit of the range is ZERO. The upper limit, which is the value when the output reaches 100%, is entered here along with the selection of engineering and time units. The range has an upper limit value of 10 m/s in flow velocity when it is calculated at the upper stage of the display. It has a lower limit value of 0.3 m/s.

Set the flow rate range so that the regular flow rate to greater than or equal to 50% of the flow rate range.

Pressing the MODE key automatically deletes unnecessary zeros, if any, from the flow rate range.

Example: 07.069 → 7.0690 (Unnecessary zero is deleted.)

Setting range:

Flow rate range: 0 to 0.0001, 0 to 99999.

Units of flow rate:

Unit of SI volume flow rate: m³, l, cm³

Unit of SI mass flow rate: t, kg, g

Unit of non-SI volume flow rate: mG, G, kG, B, mIG, IG, kIG

Unit of SI mass flow rate: lb

Unit of time: d, h, min., s

Default: 10.000 m³/h

Set the flow rate range in accordance with the following procedure:

Step	Procedure	Screen
1	Enter ENGINEERING MODE in accordance with the entry into ENGINEERING MODE (see section 5-5-9 on page 5-30). Then press the ↑ or ↓ key to display the screen at right.	<div style="border: 1px solid black; padding: 5px; width: fit-content;"> <div style="text-align: right;">12.3 %</div> <div># 1.4147 m/s</div> <div>SPAN 10.000 m³/h</div> </div>
2	Press the → key to move the cursor to a desired digit to be set.	<div style="border: 1px solid black; padding: 5px; width: fit-content;"> <div style="text-align: right;">12.3 %</div> <div># 1.4147 m/s</div> <div>SPAN <u>10.000</u> m³/h</div> </div>
3	Using the ↑ or ↓ key, change the value to a desired one.	<div style="border: 1px solid black; padding: 5px; width: fit-content;"> <div style="text-align: right;">12.3 %</div> <div># 1.4147 m/s</div> <div>SPAN 20.000 m³/h</div> </div>
4	In addition, press the → key to move the cursor to the position under a desired flow rate unit. Using the ↑ or ↓ key, select the unit.	<div style="border: 1px solid black; padding: 5px; width: fit-content;"> <div style="text-align: right;">12.3 %</div> <div># 1.4147 m/s</div> <div>SPAN 20.000 <u>l</u>/h</div> </div>
5	Then press the → key to move the cursor to the position under the time unit. Using the ↑ or ↓ key, select the unit.	<div style="border: 1px solid black; padding: 5px; width: fit-content;"> <div style="text-align: right;">12.3 %</div> <div># 1.4147 m/s</div> <div>SPAN 333.33/<u>min</u></div> </div>
6	Press the → key to move the cursor to the position under #. Press MODE key to return to the MEASURING MODE, and to save data.	<div style="border: 1px solid black; padding: 5px; width: fit-content;"> <div style="text-align: right;">12.3 %</div> <div><u>#</u> 1.4147 m/s</div> <div>SPAN 333.33/ min</div> </div>

⚠ CAUTION

You have only ten minutes to return to MEASURING MODE to save the new value before the system resets it to the previously saved value.

5-6-5 : Setting and changing compensation coefficient

This function is used to set or change the compensation coefficient which is used to multiply the output flow rate as required.

Set range: 0.10000 to 5.9999

Default: 1.0000

Set and change a compensation coefficient in accordance with the following procedure:

Step	Procedure	Screen
1	Enter ENGINEERING MODE in accordance with the entry into ENGINEERING MODE (see section 5-5-9 on page 5-30). Then press the ↑ or ↓ key to display the screen at right.	<div style="border: 1px solid black; padding: 5px; text-align: right;"> 12.3 % # COEFFICIENT 1.0000 </div>
2	Press the → key to move the cursor to the position under a desired value to be set or changed.	<div style="border: 1px solid black; padding: 5px; text-align: right;"> 12.3 % # COEFFICIENT 1.00<u>0</u> </div>
3	Using the ↑ or ↓ key, change the value to the desired one to be set.	<div style="border: 1px solid black; padding: 5px; text-align: right;"> 12.3 % # COEFFICIENT 1.00<u>5</u>0 </div>
4	Press the → key to move the cursor to the position under #. Press the MODE key to return to the MEASURING MDOE and to save data.	<div style="border: 1px solid black; padding: 5px; text-align: right;"> 12.3 % # COEFFICIENT 1.0050 </div>

⚠ CAUTION

You have only ten minutes to return to MEASURING MODE to save the new value before the system resets it to the previously saved value.

5-6-6 : Setting specific gravity

This function is used to set the specific gravity when selecting a weight unit (t, kg, g, lb) in the flow rate range setting.

Set range: 0.1000 to 5.9999

Default: 1.0000

Set the specific gravity in accordance with the following procedure:

Step	Procedure	Screen
1	Enter ENGINEERING MODE in accordance with the entry into ENGINEERING MODE (see section 5-5-9 on page 5-30). Then press the ↑ or ↓ key to display the screen at right.	<div style="border: 1px solid black; padding: 5px; width: fit-content;"> <div style="text-align: right;">12.3 %</div> <div># GRAVITY</div> <div style="text-align: right;">1.0000</div> </div>
2	Press the → key to move the cursor to the position under a desired value to be set or changed.	<div style="border: 1px solid black; padding: 5px; width: fit-content;"> <div style="text-align: right;">12.3 %</div> <div># GRAVITY</div> <div style="text-align: right;">1.00<u>0</u></div> </div>
3	Using the ↑ or ↓ key, change the value to the desired one to be set.	<div style="border: 1px solid black; padding: 5px; width: fit-content;"> <div style="text-align: right;">12.3 %</div> <div># GRAVITY</div> <div style="text-align: right;">1.00<u>5</u>0</div> </div>
4	Press the → key to move the cursor to the position under #. Press the MODE key to return to the MEASURING MODE and to save data.	<div style="border: 1px solid black; padding: 5px; width: fit-content;"> <div style="text-align: right;">12.3 %</div> <div># GRAVITY</div> <div style="text-align: right;">1.0050</div> </div>

 **CAUTION**

You have only ten minutes to return to MEASURING MODE to save the new value before the system resets it to the previously saved value.

5-6-7 : Setting pulse scale

This function is used to set the flow rate per pulse and associated units for a flowmeter. Pulse scale of the totalization value indicated on the display is equal to the pulse scale set here.

Set range: 0.0001 to 99999.

However, the pulse scale should be set so that the pulse output span frequency f_s (shown in the auxiliary display) is between 0.0001 Hz and 200 Hz.

$$0.0001 \text{ Hz} \leq f_s \leq 200 \text{ Hz}$$

Units of flow rate:

Unit of SI volume flow rate: $\text{m}^3, \text{l}, \text{cm}^3$

Unit of SI mass flow rate: $\text{t}, \text{kg}, \text{g}$

Unit of non-SI volume flow rate: $\text{mG}, \text{G}, \text{kG}, \text{B}, \text{mIG}, \text{IG}, \text{kIG}$

Unit of SI mass flow rate: lb

Unit of time: $\text{d}, \text{h}, \text{min.}, \text{s}$

Default: $10.000 \text{ m}^3/\text{P}$

~Note *Select the same unit systems (volume unit or mass unit) for the flow rate range and pulse scale. Selection of different unit systems for them will cause set errors (Err-22 PULSE WEIGHT SETTING ERROR). (See page 5-64.)*

Calculation method of span frequency:

Span frequency f_s can be calculated by the following formula:

$$f_s = (\text{Flow rate range}) / (\text{Pulse scale})$$

To calculate f_s , pay attention to the following points:

- * Convert flow range into the range per second.
- * Select the same unit of flow rate for flow rate range and pulse scale.

Example) When flow rate range: 60 l/min. , and pulse scale: $10 \text{ cm}^3/\text{P}$:

1. Convert the flow rate range into the flow rate range per second.
 $60 \text{ l/min.} \rightarrow 60/60 \text{ l/s}$
 $= 1 \text{ l/s}$
2. Select the same unit of flow rate for flow rate range and pulse scale.
 In this example, the unit of pulse scale is changed.
 $10 \text{ cm}^3/\text{P} \rightarrow 10/1000 \text{ l/P}$
 $= 0.01 \text{ l/P}$
3. Calculate the span frequency.
 $(1 \text{ l/P}) / (0.01 \text{ l/P})$
 $= 100 \text{ Hz}$
 $f_s = 100 \text{ Hz}$

Set pulse scale in accordance with the following procedure:

Step	Procedure	Screen						
1	Enter ENGINEERING MODE in accordance with the entry into ENGINEERING MODE (see section 5-5-9 on page 5-30). Then press the ↑ or ↓ key to display the screen at right.	<table border="1"> <tr> <td></td> <td>12.3 %</td> </tr> <tr> <td># PLS</td> <td>27.780 Hz</td> </tr> <tr> <td>SCL</td> <td>100.00 l/p</td> </tr> </table>		12.3 %	# PLS	27.780 Hz	SCL	100.00 l/p
	12.3 %							
# PLS	27.780 Hz							
SCL	100.00 l/p							
2	Press the → key to move the cursor to the position under a desired value to be set or changed.	<table border="1"> <tr> <td></td> <td>12.3 %</td> </tr> <tr> <td># PLS</td> <td>27.780 Hz</td> </tr> <tr> <td>SCL</td> <td><u>100.00</u> l/p</td> </tr> </table>		12.3 %	# PLS	27.780 Hz	SCL	<u>100.00</u> l/p
	12.3 %							
# PLS	27.780 Hz							
SCL	<u>100.00</u> l/p							
3	Using the ↑ or ↓key, change the value to a desired pulse scale to be set.	<table border="1"> <tr> <td></td> <td>12.3 %</td> </tr> <tr> <td># PLS</td> <td>13.890 Hz</td> </tr> <tr> <td>SCL</td> <td><u>200.00</u> l/p</td> </tr> </table>		12.3 %	# PLS	13.890 Hz	SCL	<u>200.00</u> l/p
	12.3 %							
# PLS	13.890 Hz							
SCL	<u>200.00</u> l/p							
4	Press the → key to move the cursor to the position under #. Press the MODE key to return to the MEASURING MDOE and to save data.	<table border="1"> <tr> <td></td> <td>12.3 %</td> </tr> <tr> <td># PLS</td> <td>13.890 Hz</td> </tr> <tr> <td>SCL</td> <td>200.00 l/p</td> </tr> </table>		12.3 %	# PLS	13.890 Hz	SCL	200.00 l/p
	12.3 %							
# PLS	13.890 Hz							
SCL	200.00 l/p							

⚠ CAUTION
You have only ten minutes to return to MEASURING MODE to save the new value before the system resets it to the previously saved value.

5-6-8 : Setting pulse width

Set a pulse width. The pulse width should be set in accordance with the specifications of the pulse receiver installed.

Set range

DUTY 50%

Pulse width that is DUTY 50% of the span frequency, and 1,000 ms (1s) maximum. The pulse duty ratio defines the pulse ON time versus the pulse OFF time as a percentage of the total pulse cycle.

NUM (setting of a real value)

0001 to 1,000 ms (1 s)

* With DUTY 50%, no setting error appears.

* With NUM (with a real value set), a setting error occurs if the pulse width exceeds the DUTY ratio of 70% in span frequency.

Default:

DUTY 50%

Method of setting pulse width:

The DUTY ratio is B/A (%) in the diagram at right.

1. NUM (when real pulse width is selected)

DUTY ratio < 70%

Set the pulse width as shown above.

Calculation method: When the range is 360 m³, and pulse scale is 2 l/P,

First convert the unit of range to calculate the span frequency.

Convert the range into the unit of per-second (/s).

$$360 \text{ m}^3/\text{s} \rightarrow 0.1 \text{ m}^3/\text{s}$$

Convert the unit of flow rate range to be same as the unit of pulse scale.

$$0.1 \text{ m}^3/\text{s} \rightarrow 0.1 * 1000 \text{ l/s} \\ 100 \text{ l/s}$$

Calculation of span frequency

$$(100 \text{ l/s}) / (2 \text{ l/P})$$

$$= 50 \text{ Hz}$$

$$50 \text{ Hz} \rightarrow 20 \text{ ms (= A)}$$

Calculation of pulse width where the DUTY ratio is equivalent to 70%

$$B = 0.7 \times A$$

$$= 0.7 \times 20 \text{ ms}$$

$$= 14 \text{ ms}$$

Therefore, set the pulse width to less than 14 ms.

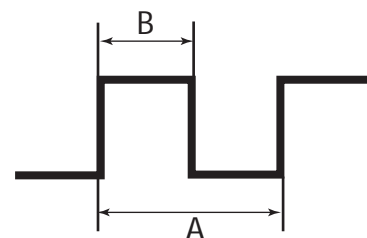

2. DUTY 50% (Automatically set)

Selecting DUTY 50% automatically sets the pulse width as follows:

Calculation method 1

Make calculations to obtain a pulse width that is DUTY 50% of the span frequency. The pulse width is automatically set. In this case, the calculated value of the pulse width does not appear on the display.

Calculation method 2

In addition, if the pulse width calculated by the calculation method 1 exceeds 1 second, the pulse width is set to 1 second.

Calculation method 1: When the range is 360 m³/h, and pulse scale is 2 l/P,

First convert the unit of range to calculate the span frequency.

Convert the range into the unit of per-second (/s).

$$360 \text{ m}^3/\text{h} \rightarrow 0.1 \text{ m}^3/\text{s}$$

Convert the unit of flow rate range to be same as the unit of pulse scale.

$$0.1 \text{ m}^3/\text{s} \rightarrow 0.1 \times 1000 \text{ l/s} \\ 100 \text{ l/s}$$

Calculation of span frequency

$$(100 \text{ l/s}) / (2 \text{ l/P})$$

$$= 50 \text{ Hz}$$

$$50 \text{ Hz} \rightarrow 20 \text{ ms} (= A)$$

Calculation of pulse width where the DUTY ratio is equivalent to 50%

$$B = 0.5 \times A \\ = 0.5 \times 20 \text{ ms} \\ = 10 \text{ ms}$$

Therefore, the pulse width is 10 ms.

Calculation method 2: When the range is 36 m³/h, and pulse scale is 100 l/P,

First convert the unit of range to calculate the span frequency.

Convert the range into the unit of per-second (/s).

$$36 \text{ m}^3/\text{h} \rightarrow 0.01 \text{ m}^3/\text{s}$$

Convert the unit of flow rate range to be same as unit of pulse scale.

$$0.01 \text{ m}^3/\text{s} \rightarrow 0.01 \times 1000 \text{ l/s} \\ 10 \text{ l/s}$$

Calculation of span frequency

$$(10 \text{ l/s}) / (100 \text{ l/p})$$

$$= 0.1 \text{ Hz}$$

$$0.1 \text{ Hz} \rightarrow 10 \text{ s} (= A)$$

Calculation of pulse width where the DUTY ratio is equivalent to 50%

$$B = 0.5 \times A \\ = 0.5 \times 10 \text{ s} \\ = 5 \text{ s}$$

Because the calculated pulse width exceeds 1 s, it takes 1s.

Set a pulse width in accordance with the following procedure:

Step	Procedure	Screen
1	Enter ENGINEERING MODE in accordance with the entry into ENGINEERING MODE (see section 5-5-9 on page 5-30). Then press the ↑ or ↓ key to display the screen at right.	<pre> 12.3 % # PLS 27.778 % WID NUM 010.00ms </pre>
2	Press the → key to move the cursor to the position under NUM.	<pre> 12.3 % # PLS 27.778 % WID <u>N</u>UM 010.00ms </pre>
3	Pressing the ↑ key switches a screen for entering a numeric value for pulse width to a screen for fixing the DUTY ratio to 50%.	<pre> 12.3 % # PLS WID <u>D</u>UTY 50 % </pre>
4	To enter a numeric value for pulse width, press the ↑ key to return to the screen for the entry of numeric values. Using the → key, move the cursor to the position under a desired digit to be set.	<pre> 12.3 % # PLS 27.778 % WID NUM 01<u>0</u>.00ms </pre>
5	Using the ↑ or ↓ key, change the value to a desired value to be set.	<pre> 12.3 % # PLS 13.889 % WID NUM 00<u>5</u>.00ms </pre>
6	Press the → key to move the cursor to the position under #. Press the MODE key to return to the MEASURING MODE and to save data.	<pre> 12.3 % # PLS 13.889 % WID NUM 005.00ms </pre>

⚠ CAUTION

You have only ten minutes to return to MEASURING MODE to save the new value before the system resets it to the previously saved value.

5-6-9 : Setting drop out

This function is used to set the drop out value for the pulse output. The pulse output will be cut off at this point to avoid flow pulsation in range values close to zero, thus preventing incorrect totalization of the flow rate.

Pulse counting pauses when the flow rate reaches this preset percentage of the set range.

Setting range: 0 to 10%

Default: 2%

Set drop out in accordance with the following procedure:

Step	Procedure	Screen
1	Enter ENGINEERING MODE in accordance with the entry into ENGINEERING MODE (see section 5-5-9 on page 5-30). Then press the ↑ or ↓ key to display the screen at right.	<div style="border: 1px solid black; padding: 5px; display: inline-block;"> <div style="text-align: right;">12.3 %</div> <div># DROPOUT</div> <div style="text-align: right;">02 %</div> </div>
2	Press the → key.	<div style="border: 1px solid black; padding: 5px; display: inline-block;"> <div style="text-align: right;">12.3 %</div> <div># DROPOUT</div> <div style="text-align: right;">0<u>2</u> %</div> </div>
3	Using the ↑ or ↓ key, change the value to a desired value to be set.	<div style="border: 1px solid black; padding: 5px; display: inline-block;"> <div style="text-align: right;">12.3 %</div> <div># DROPOUT</div> <div style="text-align: right;">0<u>5</u> %</div> </div>
4	Press the → key to move the cursor to the position under #. Press the MODE key to return to the MEASUREMENT MODE and to save data.	<div style="border: 1px solid black; padding: 5px; display: inline-block;"> <div style="text-align: right;">12.3 %</div> <div># DROPOUT</div> <div style="text-align: right;">05 %</div> </div>

⚠ CAUTION

You have only ten minutes to return to MEASURING MODE to save the new value before the system resets it to the previously saved value.

5-6-10 : Setting low flow cutoff

This function is used to set the low flow cutoff value. When the flow rate reaches the entered value, the analog output is cut off and latched to 4 mA (display flow rate of 0%) to avoid errors due to flow pulsation in range value close to zero.

Also, for reverse flow rate the output is latched to 4 mA (display flow rate of 0%)

The lower limit of the low flow cutoff setting is determined by the velocity range.

1. If the velocity range exceeds 3 m/s, the lower limit value is 1%.
2. If the flow speed range is 3 m/s or less, the lower limit value will cut the flow speed of 0.03 m/s or less flow the rate.

Example: If the flow speed range is set as 2 m/s, the lower limit of the low flow cutoff value is 1.5%. ($= 0.03/2 = 0.015 = 1.5\%$)

Setting range: 1 to 10%

Default: Depends on the velocity range.

Set low flow cut in accordance with the following procedure:

Step	Procedure	Screen
1	Enter ENGINEERING MODE in accordance with the entry into ENGINEERING MODE (see section 5-5-9 on page 5-30). Then press the ↑ or ↓ key to display the screen at right.	<div style="border: 1px solid black; padding: 5px; text-align: right;"> 12.3 % # LOW-FLOW CUT 02 % </div>
2	Press the → key. The cursor then moves to the position of the low flow cut value.	<div style="border: 1px solid black; padding: 5px; text-align: right;"> 12.3 % # LOW-FLOW CUT 0<u>2</u> % </div>
3	Using the ↑ or ↓ key, change the value to a desired value to be set.	<div style="border: 1px solid black; padding: 5px; text-align: right;"> 12.3 % # LOW-FLOW CUT 0<u>5</u> % </div>
4	Press the → key to move the cursor to the position under #. Press the MODE key to return to MEASURING MODE and to save data.	<div style="border: 1px solid black; padding: 5px; text-align: right;"> 12.3 % # LOW-FLOW CUT 05 % </div>

⚠ CAUTION

You have only ten minutes to return to MEASURING MODE to save the new value before the system resets it to the previously saved value.

5-6-11 : Setting upper and lower limit alarm

This function is used to set the upper and lower limit alarm set points when the contact output is selected.

An alarm is output when the flow rate exceeds these preset upper and lower limits.

The alarm output status depends on the “Setting contact output status” described later.

Set range: HI-ALM 0% to +115%
 LO-ALM 0% to +115%

Default: HI-ALM +115%
 LO-ALM 0%

Set the upper/lower limit alarm in accordance with the following procedure:

Step	Procedure	Screen						
1	Enter ENGINEERING MODE in accordance with the entry into ENGINEERING MODE (see section 5-5-9 on page 5-30). Then press the ↑ or ↓ key to display the screen at right.	<table border="1"> <tr> <td></td> <td>12.3 %</td> </tr> <tr> <td># HI-ALM</td> <td>+115%</td> </tr> <tr> <td>LO-ALM</td> <td>+000%</td> </tr> </table>		12.3 %	# HI-ALM	+115%	LO-ALM	+000%
	12.3 %							
# HI-ALM	+115%							
LO-ALM	+000%							
2	Using the → key, move the cursor to the position under a digit to be set or changed.	<table border="1"> <tr> <td></td> <td>12.3 %</td> </tr> <tr> <td># HI-ALM</td> <td>+1<u>0</u>0%</td> </tr> <tr> <td>LO-ALM</td> <td>-000%</td> </tr> </table>		12.3 %	# HI-ALM	+1 <u>0</u> 0%	LO-ALM	-000%
	12.3 %							
# HI-ALM	+1 <u>0</u> 0%							
LO-ALM	-000%							
3	Using the ↑ or ↓ key, change the value to the desired value to be set.	<table border="1"> <tr> <td></td> <td>12.3 %</td> </tr> <tr> <td># HI-ALM</td> <td>+0<u>8</u>0%</td> </tr> <tr> <td>LO-ALM</td> <td>-000%</td> </tr> </table>		12.3 %	# HI-ALM	+0 <u>8</u> 0%	LO-ALM	-000%
	12.3 %							
# HI-ALM	+0 <u>8</u> 0%							
LO-ALM	-000%							
4	Press the → key to move the cursor to the position under #. Press MODE key to return to the MEASURING MODE and to save data.	<table border="1"> <tr> <td></td> <td>12.3 %</td> </tr> <tr> <td># HI-ALM</td> <td>+080%</td> </tr> <tr> <td>LO-ALM</td> <td>-000%</td> </tr> </table>		12.3 %	# HI-ALM	+080%	LO-ALM	-000%
	12.3 %							
# HI-ALM	+080%							
LO-ALM	-000%							

However, set as follows: HI-ALM > LO-ALM.

5-6-12 : Selecting failsafe mode for analog outputs

This function is used to determine the analog output direction when the flowmeter detects a critical status condition.

⚠ CAUTION

The failsafe mode is very important for the overall safety of the control process. Choose the failsafe direction carefully, as equipment damage can result from a wrong choice.

Setting range: **LOW** Analog output is driven to low scale (TYP 3.7 mA)
HIGH Analog output is driven to high scale (TYP 21.8 mA)
HOLD Analog output is held at its last good value.

Default: **LOW**

Set failsafe mode for analog output in accordance with the following procedure:

Step	Procedure	Screen
1	Enter ENGINEERING MODE in accordance with the entry into ENGINEERING MODE (see section 5-5-9 on page 5-30). Then press the ↑ or ↓ key to display the screen at right.	<div style="border: 1px solid black; padding: 5px; text-align: right;"> 12.3 % # ERROR OUT MODE I.OUT LOW </div>
2	Press the → key.	<div style="border: 1px solid black; padding: 5px; text-align: right;"> 12.3 % # ERROR OUT MODE I.OUT <u>L</u>OW </div>
3	Using the ↑ or ↓ key, determine the failsafe mode for analog output.	<div style="border: 1px solid black; padding: 5px; text-align: right;"> 12.3 % # ERROR OUT MODE I.OUT <u>H</u>IGH </div>
4	Press the → key to move the cursor to the position under #. Press the MODE key to return to the MEASURING MODE and to save data.	<div style="border: 1px solid black; padding: 5px; text-align: right;"> 12.3 % # ERROR OUT MODE I.OUT HIGH </div>

⚠ CAUTION

You have only ten minutes to return to MEASURING MODE to save the new value before the system resets it to the previously saved value.

5-6-13 : Selecting failsafe mode for pulse output

This function is used to determine the pulse output direction when the flowmeter detects a critical status condition.

⚠ CAUTION
The failsafe mode is very important for the overall safety of the control process. Choose the failsafe direction carefully, as equipment damage can result from a wrong choice.

Set range: OFF Outputs no pulse.
 HOLD Pulse output signal held at its present state
 Default: OFF

Set failsafe mode for pulse output in accordance with the following procedure:

Step	Procedure	Screen
1	Enter ENGINEERING MODE in accordance with the entry into ENGINEERING MODE (see section 5-5-9 on page 5-30). Then press the ↑ or ↓ key to display the screen at right.	<div style="text-align: right;">12.3 %</div> <div># ERROR OUT MODE</div> <div>P.OUT OFF</div>
2	Press the → key.	<div style="text-align: right;">12.3 %</div> <div># ERROR OUT MODE</div> <div>P.OUT <u>OFF</u></div>
3	Using the ↑ or ↓ key, determine the failsafe mode for pulse output.	<div style="text-align: right;">12.3 %</div> <div># ERROR OUT MODE</div> <div>P.OUT <u>HOLD</u></div>
4	Press the → key to move the cursor to the position under #. Press the MODE key to return to the MEASURING MODE and to save data.	<div style="text-align: right;">12.3 %</div> <div># ERROR OUT MODE</div> <div>P.OUT HOLD</div>

⚠ CAUTION
You have only ten minutes to return to MEASURING MODE to save the new value before the system resets it to the previously saved value.

5-6-14 : Setting contact output status

This function is used to set contact output status for normal operation.

This function is effective only when contact output has been selected in the function specification.

Set range: CLOSE Sets the open collector output to ON.

OPEN Sets the open collector output to OFF.

Default: OPEN

Set the contact output status in accordance with the following procedure:

Step	Procedure	Screen
1	Enter ENGINEERING MODE in accordance with the entry into ENGINEERING MODE (see section 5-5-9 on page 5-30). Then press the ↑ or ↓ key to display the screen at right.	<div style="border: 1px solid black; padding: 5px; width: fit-content;"> <div style="text-align: right;">12.3 %</div> # ST. OUT MODE NORMAL CLOSE </div>
2	Press the → key.	<div style="border: 1px solid black; padding: 5px; width: fit-content;"> <div style="text-align: right;">12.3 %</div> # ST. OUT MODE NORMAL <u>C</u>LOSE </div>
3	Using the ↑ key, set the contact output status.	<div style="border: 1px solid black; padding: 5px; width: fit-content;"> <div style="text-align: right;">12.3 %</div> # ST. OUT MODE NORMAL <u>O</u>PEN </div>
4	Press the → key to move the cursor to the position under #. Press the MODE key to return to the MEASURING MODE and to save data.	<div style="border: 1px solid black; padding: 5px; width: fit-content;"> <div style="text-align: right;">12.3 %</div> # ST. OUT MODE NORMAL OPEN </div>

⚠ CAUTION

You have only ten minutes to return to MEASURING MODE to save the new value before the system resets it to the previously saved value.

5-7 : Configuration of MAINTENANCE MODE

Introduction

MAINTENANCE MODE consists of the following three types: OUTPUT CHECK MODE, CALIBRATION MODE, and CRITICAL MODE. For details on the modes, see the following pages.

LCD display flow

The LCD display flow of MAINTENACE MODE is as follows:

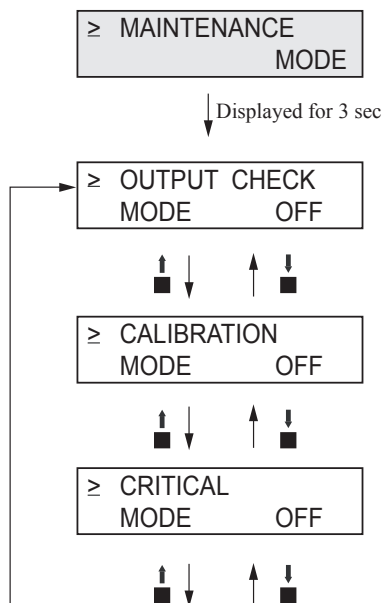

5-7-1 : Configuration of OUTPUT CHECK MODE

Introduction

OUTPUT CHECK MODE has the following setting and adjustment items.

For details on the function of items, see the following pages.

Item	Content	Screen
OUTPUT CHECK I.OUT	Outputs a fixed value of analog current output to perform loop checks.	<div style="border: 1px solid black; padding: 5px; width: fit-content;"> <div style="text-align: right;">12.3 %</div> <div style="text-align: center;">≥ OUTPUT CHECK</div> <div style="text-align: right;">I.OUT 100%</div> </div>
OUTPUT CHECK P.OUT	Outputs a fixed value of pulse output to perform loop checks.	<div style="border: 1px solid black; padding: 5px; width: fit-content;"> <div style="text-align: right;">12.3 %</div> <div style="text-align: center;">≥ OUTPUT CHECK</div> <div style="text-align: right;">P.OUT 100%</div> </div>
OUTPUT CHECK ST.OUT	Outputs a fixed value of contact output to perform loop checks.	<div style="border: 1px solid black; padding: 5px; width: fit-content;"> <div style="text-align: right;">12.3 %</div> <div style="text-align: center;">≥ OUTPUT CHECK</div> <div style="text-align: right;">ST.OUT CLOSE</div> </div>
OUTPUT CHECK EX	Outputs a fixed value of excitation current. This value was calibrated in the factory. DO NOT configure this value.	<div style="border: 1px solid black; padding: 5px; width: fit-content;"> <div style="text-align: right;">12.3 %</div> <div style="text-align: center;">≥ OUTPUT CHECK</div> <div style="text-align: right;">EX EX1</div> </div>

LCD display flow

The screen flow of OUTPUTCHECK MODE is as follows:

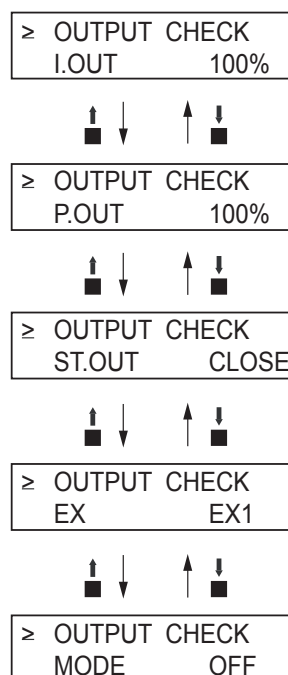

5-7-2 : Performing loop checks of analog outputs

Analog output check

The electromagnetic flowmeter can be used as a constant current generator to check analog outputs. Other instruments in the analog current output loop, such as recorders and controllers can be checked.

Default setting

Displays the current output value.

Setting range

Range settings are allowed ranging from 0 to 100%.

Perform loop checks of analog outputs in accordance with the following procedure:

Step	Procedure	Screen
1	Enter MAINTENANCE MODE in accordance with the entry into MAINTENANCE MODE (see section 5-5-9 on page 5-30). Then display the screen at right.	<div style="border: 1px solid black; padding: 5px; width: fit-content;"> <div style="text-align: right;">20.0 %</div> ≥ OUTPUT CHECK MODE OFF </div>
2	Press the → key to move the cursor to the OFF position. Press the ↑ key. With the display switched from OFF to ON, the output check mode is then active.	<div style="border: 1px solid black; padding: 5px; width: fit-content;"> <div style="text-align: right;">20.0 %</div> > OUTPUT CHECK MODE <u>OFF</u> </div> <div style="border: 1px solid black; padding: 5px; width: fit-content;"> <div style="text-align: right;">20.0 %</div> > OUTPUT CHECK MODE <u>ON</u> </div> <div style="border: 1px solid black; padding: 5px; width: fit-content;"> <div style="text-align: right;">20.0 %</div> ≥ OUTPUT CHECK I.OUT 000.0% </div>
3	Press the → key to move the cursor to the position under a desired value to be checked.	<div style="border: 1px solid black; padding: 5px; width: fit-content;"> <div style="text-align: right;">20.0 %</div> > OUTPUT CHECK I.OUT <u>000.0%</u> </div>
4	Pressing the ↑ or ↓ key, change the value to the desired value to be checked. As shown on the screen on the right, the output to the range, given as an analog output, is 100% i.e. 20 mA.	<div style="border: 1px solid black; padding: 5px; width: fit-content;"> <div style="text-align: right;">20.0 %</div> > OUTPUT CHECK I.OUT <u>100.0%</u> </div>
5	Press the → key to move the cursor to the position under >. Movement to another screen by using the ↑ or ↓ key returns to an analog output according to the actual flow rate.	<div style="border: 1px solid black; padding: 5px; width: fit-content;"> <div style="text-align: right;">20.0 %</div> ≥ OUTPUT CHECK I.OUT 100.0% </div>

5-7-3 : Performing loop checks of pulse outputs

Pulse output check

The electromagnetic flowmeter can be used as a pulse generator to check pulse outputs.

This screen appears when pulse output has been selected in FUNC SET of ENGINEERING MODE (see “5-6-2 : Selecting pulse output or contact output”).

Default setting

Displays the current output value.

Setting range

Range settings are allowed ranging from 0 to 100%.

Perform loop checks of pulse outputs in accordance with the following procedure:

Step	Procedure	Screen
1	Enter MAINTENANCE MODE in accordance with the entry into MAINTENANCE MODE (see section 5-5-9 on page 5-30). Then display the screen at right.	<div style="border: 1px solid black; padding: 5px; width: fit-content;"> <div style="text-align: right;">20.0 %</div> ≥ OUTPUT CHECK MODE OFF </div>
2	Press the → key to move the cursor to the OFF position. Press the - key. With the display switched from OFF to ON, the output check mode is then active.	<div style="border: 1px solid black; padding: 5px; width: fit-content;"> <div style="text-align: right;">20.0 %</div> > OUTPUT CHECK MODE OFF </div> <div style="border: 1px solid black; padding: 5px; width: fit-content;"> <div style="text-align: right;">20.0 %</div> > OUTPUT CHECK MODE ON </div> <div style="border: 1px solid black; padding: 5px; width: fit-content;"> <div style="text-align: right;">20.0 %</div> ≥ OUTPUT CHECK I.OUT 000.0% </div>
3	Press the ↑ key to display the screen at right.	<div style="border: 1px solid black; padding: 5px; width: fit-content;"> <div style="text-align: right;">20.0 %</div> ≥ OUTPUT CHECK P.OUT 000.0% </div>
4	Press the → key to move the cursor to the position under a desired value to be checked.	<div style="border: 1px solid black; padding: 5px; width: fit-content;"> <div style="text-align: right;">20.0 %</div> > OUTPUT CHECK P.OUT 000.0% </div>
5	Pressing the ↑ or ↓ key, change the value to the desired value to be checked. On the screen at right, a frequency pulse corresponding to flow rate signal 100% is output.	<div style="border: 1px solid black; padding: 5px; width: fit-content;"> <div style="text-align: right;">20.0 %</div> > OUTPUT CHECK I.OUT 100.0% </div>
6	Press the → key to move the cursor to the position shown on the screen at right. Movement to another screen by using the ↑ or ↓ key returns to a pulse output according to the actual flow rate.	<div style="border: 1px solid black; padding: 5px; width: fit-content;"> <div style="text-align: right;">20.0 %</div> ≥ OUTPUT CHECK I.OUT 100.0% </div>

5-7-4 : Performing loop checks of contact outputs

Contact output check

Contact outputs of electromagnetic flowmeter can be turned on and off to perform loop checks of contact output signals.

This screen appears when contact output has been selected in FUNC SET of ENGINEERING MODE (see “5-6-2 : Selecting pulse output or contact output”).

Default setting

Displays the current contact output status.

Setting range

Set range “CLOSE” and “OPEN”

Perform loop checks of contact outputs in accordance with the following procedure:

Step	Procedure	Screen
1	Enter MAINTENANCE MODE in accordance with the entry into MAINTENANCE MODE (see section 5-5-9 on page 5-30). Then display the screen at right.	<div style="border: 1px solid black; padding: 5px; width: fit-content;"> <div style="text-align: right;">20.0 %</div> <div style="text-align: center;">≥ OUTPUT CHECK</div> <div style="text-align: center;">MODE OFF</div> </div>
2	Press the → key to move the cursor to the OFF position. Press the ↑ key. With the display switched from OFF to ON, the output check mode is then active.	<div style="border: 1px solid black; padding: 5px; width: fit-content;"> <div style="text-align: right;">20.0 %</div> <div style="text-align: center;">> OUTPUT CHECK</div> <div style="text-align: center;">MODE <u>OFF</u></div> </div> <div style="border: 1px solid black; padding: 5px; width: fit-content;"> <div style="text-align: right;">20.0 %</div> <div style="text-align: center;">> OUTPUT CHECK</div> <div style="text-align: center;">MODE <u>ON</u></div> </div> <div style="border: 1px solid black; padding: 5px; width: fit-content;"> <div style="text-align: right;">20.0 %</div> <div style="text-align: center;">≥ OUTPUT CHECK</div> <div style="text-align: center;">I.OUT 000.0%</div> </div>
3	Press the ↑ key twice to display the screen at right. In this status, a contact output corresponding to the display is output.	<div style="border: 1px solid black; padding: 5px; width: fit-content;"> <div style="text-align: right;">20.0 %</div> <div style="text-align: center;">≥ OUTPUT CHECK</div> <div style="text-align: center;">ST.OUT CLOSE</div> </div>
4	Press the → key to move the cursor to the OPEN or CLOSE position that indicates the status of contact output.	<div style="border: 1px solid black; padding: 5px; width: fit-content;"> <div style="text-align: right;">20.0 %</div> <div style="text-align: center;">> OUTPUT CHECK</div> <div style="text-align: center;">ST.OUT <u>CLOSE</u></div> </div>
5	Press the → key to move the cursor to the position under >. Movement to another screen by using the ↑ or ↓ key returns the contact output to the output status according to the current status.	<div style="border: 1px solid black; padding: 5px; width: fit-content;"> <div style="text-align: right;">12.3 %</div> <div style="text-align: center;">≥ OUTPUT CHECK</div> <div style="text-align: center;">ST.OUT CLOSE</div> </div>

5-7-5 : Configuration of CALIBRATION MODE

Introduction

CALIBRATION MODE has the following setting and adjustment items:

Configuration of CALIBRATION MODE requires a dedicated calibrator.

Wrong operation may hinder accurate measurements of the flow rate. To operate in this mode, contact your local Yamatake representative.

Item	Content	Screen									
CAL EX LOW 3.5 mA	Adjusts 3.5 mA excitation current.	<div style="border: 1px solid black; padding: 5px; width: fit-content;"> <table style="width: 100%; border-collapse: collapse;"> <tr> <td style="width: 10%; text-align: right;">≥</td> <td style="width: 60%;">CAL EX</td> <td style="width: 30%; text-align: right;">12.3 %</td> </tr> <tr> <td></td> <td>LOW</td> <td style="text-align: right;">OFF</td> </tr> <tr> <td></td> <td></td> <td style="text-align: right;">3.5 mA</td> </tr> </table> </div>	≥	CAL EX	12.3 %		LOW	OFF			3.5 mA
≥	CAL EX	12.3 %									
	LOW	OFF									
		3.5 mA									
CAL EX 4.9 mA	Adjusts 4.9 mA excitation current.	<div style="border: 1px solid black; padding: 5px; width: fit-content;"> <table style="width: 100%; border-collapse: collapse;"> <tr> <td style="width: 10%; text-align: right;">≥</td> <td style="width: 60%;">CAL EX</td> <td style="width: 30%; text-align: right;">12.3 %</td> </tr> <tr> <td></td> <td></td> <td style="text-align: right;">OFF</td> </tr> <tr> <td></td> <td></td> <td style="text-align: right;">4.9 mA</td> </tr> </table> </div>	≥	CAL EX	12.3 %			OFF			4.9 mA
≥	CAL EX	12.3 %									
		OFF									
		4.9 mA									
CAL EX 7.0 mA	Adjusts 7.0 mA excitation current.	<div style="border: 1px solid black; padding: 5px; width: fit-content;"> <table style="width: 100%; border-collapse: collapse;"> <tr> <td style="width: 10%; text-align: right;">≥</td> <td style="width: 60%;">CAL EX</td> <td style="width: 30%; text-align: right;">12.3 %</td> </tr> <tr> <td></td> <td></td> <td style="text-align: right;">OFF</td> </tr> <tr> <td></td> <td></td> <td style="text-align: right;">7.0 mA</td> </tr> </table> </div>	≥	CAL EX	12.3 %			OFF			7.0 mA
≥	CAL EX	12.3 %									
		OFF									
		7.0 mA									
CAL EX 11.9 mA	Adjusts 11.9 mA excitation current.	<div style="border: 1px solid black; padding: 5px; width: fit-content;"> <table style="width: 100%; border-collapse: collapse;"> <tr> <td style="width: 10%; text-align: right;">≥</td> <td style="width: 60%;">CAL EX</td> <td style="width: 30%; text-align: right;">12.3 %</td> </tr> <tr> <td></td> <td></td> <td style="text-align: right;">OFF</td> </tr> <tr> <td></td> <td></td> <td style="text-align: right;">11.9 mA</td> </tr> </table> </div>	≥	CAL EX	12.3 %			OFF			11.9 mA
≥	CAL EX	12.3 %									
		OFF									
		11.9 mA									
CAL EX 14.0 mA	Adjusts 14.0 mA excitation current.	<div style="border: 1px solid black; padding: 5px; width: fit-content;"> <table style="width: 100%; border-collapse: collapse;"> <tr> <td style="width: 10%; text-align: right;">≥</td> <td style="width: 60%;">CAL EX</td> <td style="width: 30%; text-align: right;">12.3 %</td> </tr> <tr> <td></td> <td></td> <td style="text-align: right;">OFF</td> </tr> <tr> <td></td> <td></td> <td style="text-align: right;">14.0 mA</td> </tr> </table> </div>	≥	CAL EX	12.3 %			OFF			14.0 mA
≥	CAL EX	12.3 %									
		OFF									
		14.0 mA									
CAL I.OUT LOW 4.000 mA	Adjusts 4 mA analog current output.	<div style="border: 1px solid black; padding: 5px; width: fit-content;"> <table style="width: 100%; border-collapse: collapse;"> <tr> <td style="width: 10%; text-align: right;">≥</td> <td style="width: 60%;">CAL I.OUT</td> <td style="width: 30%; text-align: right;">12.3 %</td> </tr> <tr> <td></td> <td>LOW</td> <td style="text-align: right;">OFF</td> </tr> <tr> <td></td> <td></td> <td style="text-align: right;">4.000 mA</td> </tr> </table> </div>	≥	CAL I.OUT	12.3 %		LOW	OFF			4.000 mA
≥	CAL I.OUT	12.3 %									
	LOW	OFF									
		4.000 mA									
CAL I.OUT HIGH 20.00 mA	Adjusts 20 mA analog current output.	<div style="border: 1px solid black; padding: 5px; width: fit-content;"> <table style="width: 100%; border-collapse: collapse;"> <tr> <td style="width: 10%; text-align: right;">≥</td> <td style="width: 60%;">CAL I.OUT</td> <td style="width: 30%; text-align: right;">12.3 %</td> </tr> <tr> <td></td> <td>HIGH</td> <td style="text-align: right;">OFF</td> </tr> <tr> <td></td> <td></td> <td style="text-align: right;">20.000 mA</td> </tr> </table> </div>	≥	CAL I.OUT	12.3 %		HIGH	OFF			20.000 mA
≥	CAL I.OUT	12.3 %									
	HIGH	OFF									
		20.000 mA									
CAL P.OUT FREQ 90 Hz	Adjusts 90 Hz pulse output.	<div style="border: 1px solid black; padding: 5px; width: fit-content;"> <table style="width: 100%; border-collapse: collapse;"> <tr> <td style="width: 10%; text-align: right;">≥</td> <td style="width: 60%;">CAL P.OUT</td> <td style="width: 30%; text-align: right;">12.3 %</td> </tr> <tr> <td></td> <td>FREQ</td> <td style="text-align: right;">OFF</td> </tr> <tr> <td></td> <td></td> <td style="text-align: right;">90 Hz</td> </tr> </table> </div>	≥	CAL P.OUT	12.3 %		FREQ	OFF			90 Hz
≥	CAL P.OUT	12.3 %									
	FREQ	OFF									
		90 Hz									

Item	Content	Screen
CAL GAIN ZERO	Adjusts 0 m/s gain.	<div style="border: 1px solid black; padding: 5px; width: fit-content;"> <div style="text-align: right;">12.3 %</div> <div style="display: flex; justify-content: space-between;"> ≥ CAL GAIN OFF </div> <div style="display: flex; justify-content: space-between;"> ZERO READY </div> </div>
CAL GAIN 2.5 m/s	Adjusts 2.5 m/s gain.	<div style="border: 1px solid black; padding: 5px; width: fit-content;"> <div style="text-align: right;">12.3 %</div> <div style="display: flex; justify-content: space-between;"> ≥ CAL GAIN OFF </div> <div style="display: flex; justify-content: space-between;"> 2.5 m/s READY </div> </div>
CAL GAIN 10.0 m/s	Adjusts 10.0 m/s gain.	<div style="border: 1px solid black; padding: 5px; width: fit-content;"> <div style="text-align: right;">12.3 %</div> <div style="display: flex; justify-content: space-between;"> ≥ CAL GAIN OFF </div> <div style="display: flex; justify-content: space-between;"> 10.0 m/s READY </div> </div>

LCD display flow

The LCD display flow of CALIBRATION MODE is as follows:

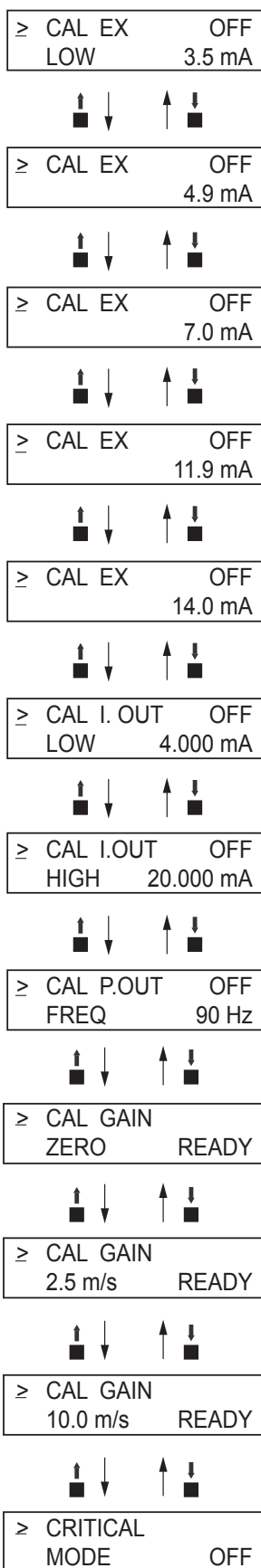

5-7-6 : Configuration of CRITICAL MODE

Introduction

CRITICAL MODE has the following setting and adjustment items:

Item	Content	Screen
ROM VER DATE	Displays the ROM version and date.	<div style="border: 1px solid black; padding: 5px; text-align: right;"> 20.0 % ≥ ROM VER. [] [] DATE YY-MM-DD </div>
SHIPPING DATA (default value) RECOVERY	You can return the device to factory setting/default values for pertinent operational and configuration parameters. These parameters are entered before the device is shipped, so they are commonly referred to as “shipping data”. They include factory calibration data and factory settings or initial default settings for customer configuration data.	<div style="border: 1px solid black; padding: 5px; text-align: right;"> 20.0 % ≥ SHIPPING DATA RECOVERY READY </div>
INITIAL DATA RECOVERY	Initial data recovery eliminates all calibration data and configuration parameters. DO NOT use this function.	<div style="border: 1px solid black; padding: 5px; text-align: right;"> 20.0 % ≥ INITIAL DATA RECOVERY READY </div>

LCD display flow

The screen flow of CRITICAL MODE is as follows:

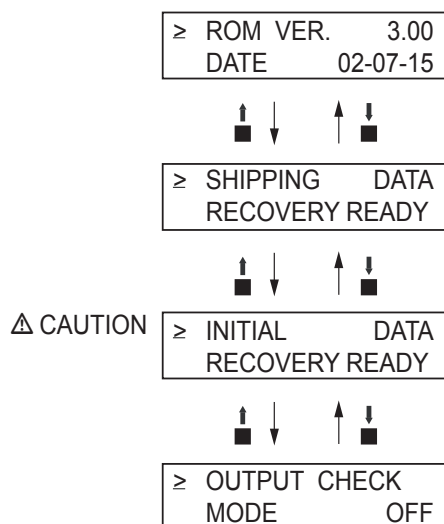

△ CAUTION

△ CAUTION

INITIAL DATA RECOVERY function is only for Yamatake service/maintenance specialist. Please DO NOT use this function. If this function is turned ON, all calibrated data will be missing. The device needs to be back to the factory to calibrate again.

5-7-7 : Displaying ROM version and date

Displaying ROM version

The ROM version and date of the converter can be displayed on the display screen.

Display the ROM version and data in accordance with the following procedure:

Step	Procedure	Screen
1	Enter MAINTENANCE MODE in accordance with the entry into MAINTENANCE MODE (see section 5-5-9 on page 5-30). Using the ↑ or ↓ key, display the screen at right.	<div style="border: 1px solid black; padding: 5px; width: fit-content;"> <div style="text-align: right;">20.0 %</div> ≥ OUTPUT CHECK MODE OFF </div>
2	Press the ↑ key twice to display the screen at right.	<div style="border: 1px solid black; padding: 5px; width: fit-content;"> <div style="text-align: right;">20.0 %</div> ≥ CRITICAL MODE OFF </div>
3	Press the → key to move the cursor to the OFF position. Then press the - key to switch the display from OFF to ON.	<div style="border: 1px solid black; padding: 5px; width: fit-content;"> <div style="text-align: right;">20.0 %</div> > CRITICAL MODE <u>ON</u> </div>
4	After the entry into CRITICAL MODE, the screen at right appears. On the screen, the ROM version and date can be checked.	<div style="border: 1px solid black; padding: 5px; width: fit-content;"> <div style="text-align: right;">20.0 %</div> ≥ ROM VER. [] [] DATE YY-MM-DD </div>

5-7-8 : Returning to settings at shipment

SHIPPING DATA (default value) RECOVERY

Performing SHIPPING DATA RECOVERY returns the internal data settings of the device to the settings at time of shipment.

Note that executing this operation erases the data that was set and changed by the customer.

Perform SHIPPING DATA RECOVERY in accordance with the following procedure:

Step	Procedure	Screen
1	Enter MAINTENANCE MODE in accordance with the entry into MAINTENANCE MODE (see section 5-5-9 on page 5-30). Using the ↑ or ↓ key, display the screen at right.	<div style="border: 1px solid black; padding: 5px; width: fit-content;"> <div style="text-align: right;">20.0 %</div> ≥ OUTPUT CHECK MODE OFF </div>
2	Press the ↑ key twice to display the screen at right.	<div style="border: 1px solid black; padding: 5px; width: fit-content;"> <div style="text-align: right;">20.0 %</div> ≥ CRITICAL MODE OFF </div>
3	Press the → key to move the cursor to the OFF position. Then press the ↑ key to switch the display from OFF to ON. After the entry into CRITICAL MODE, the screen at right appears.	<div style="border: 1px solid black; padding: 5px; width: fit-content;"> <div style="text-align: right;">20.0 %</div> > CRITICAL MODE <u>ON</u> </div> <div style="border: 1px solid black; padding: 5px; width: fit-content;"> <div style="text-align: right;">20.0 %</div> ≥ ROM VER. DATE YY-MM-DD </div>
4	Press the ↑ key to display the screen at right.	<div style="border: 1px solid black; padding: 5px; width: fit-content;"> <div style="text-align: right;">20.0 %</div> ≥ SHIPPING DATA RECOVERY READY </div>
5	Press the → key to move the cursor to the READY position, and then keep pressing the ↑ key for three seconds or more.	<div style="border: 1px solid black; padding: 5px; width: fit-content;"> <div style="text-align: right;">20.0 %</div> > SHIPPING DATA RECOVERY <u>READY</u> </div>
6	SHIPPING DATA RECOVER starts. The display will change as shown on the screen at right.	<div style="border: 1px solid black; padding: 5px; width: fit-content;"> <div style="text-align: right;">20.0 %</div> > SHIPPING DATA RECOVERY <u>ON</u> </div> <div style="border: 1px solid black; padding: 5px; width: fit-content;"> <div style="text-align: right;">8.8.8.8.8.8.8.8 % RATE TOTAL</div> <div style="background-color: #4a4a8a; height: 10px; width: 100%;"></div> <div style="background-color: #4a4a8a; height: 10px; width: 100%;"></div> </div> <div style="border: 1px solid black; padding: 5px; width: fit-content;"> - SELF CHECK MODE </div>
7	When SHIPPING DATA RECOVERY ends, the data settings return to those at the time of shipping, and then the MEASURING MODE screen reappears.	<div style="border: 1px solid black; padding: 5px; width: fit-content;"> <div style="text-align: right;">20.0 %</div> 01.94 m³/h WPO 00069401 </div>

5-8 : Description of Error Messages

Introduction

Errors are classified into critical failure and non-critical failure.

Critical failure

Critical failure may obstruct the electromagnetic flowmeter operation, if not corrected, ultimately damage the flowmeter. When critical failure occurs during operation, an error message will appear on the converter's display and the electromagnetic flowmeter will continue to output the preset value in the abnormality treatment (failsafe) direction. The error message and the self-diagnostic results will be visible on the display.

Perform the proper correction measures, referring to the actions below.

Error code of serious trouble

Error code	Error content	Action	LCD display
Err-02	CPU (ROM, RAM) CHECK SUM ERROR	1. Restore power. 2. Replace ROM. 3. Replace main P/C.	Err - 02 CPU CHECK ERROR
Err-04	NVM READ AFTER WRITE ERROR	1. Restore power. 2. Replace main P/C.	Err - 04 NVM CHECK ERROR

Non-critical error

Non-critical failures will not seriously affect electromagnetic flowmeter operation. When an error occurs during operation and is regarded as a non-critical problem by the converter self-diagnostics, the output will not burn-out and the electromagnetic flowmeter will continue to output the measured value.

If a wrong setting is found, an error message is displayed for a second, and then the screen set wrongly is displayed.

Error code of set errors

Error code	Error content	Action	LCD display
Err-12	Upper/lower limit alarm set error HI < LO is set.	Set HI>LO.	<div style="border: 1px solid black; padding: 5px; width: fit-content;"> Err - 12 SETTING ERROR HI<LO </div>
Err-21	Span is set to 12 m/s or more.	Check the settings of flow rate range and detector information (bore diameter and detector type).	<div style="border: 1px solid black; padding: 5px; width: fit-content;"> Err - 21 SPAN ERROR OVER 12 m/s </div>
Err-22	Pulse frequency is too large or too small. The flow rate range unit system is different from the pulse unit system. Example: SPAN m ³ /h pulse scale t/h	1. Check pulse scale. 2. Check the setting of pulse frequency. 3. Adopt a unified unit system.	<div style="border: 1px solid black; padding: 5px; width: fit-content;"> Err - 22 PULSE WEIGHT SETTING ERROR </div>
Err-23	The pulse width is too large. When pulse frequency is output, the duty is 70% or more.	Check the following settings: 1. Pulse width 2. pulse scale 3. Span	<div style="border: 1px solid black; padding: 5px; width: fit-content;"> Err - 23 PULSE WIDTH OVER DUTY 70% </div>

Chapter 6 : Maintenance and troubleshooting

Outline of this chapter

This chapter presents an instrument maintenance and maintenance procedure and information to refer to when doing troubleshooting. Ensure the procedure for maintenance based on the trouble.

6-1 : Maintenance and inspection of hardware

Replacement of indicator/data setter

Procedure

Replacement procedure is as follows.

Step	Procedure
1	The converter front cover is fixed by hexagon socket head screws (M3). Loosen these screws with an Allen wrench (1.5).
2	Remove the converter front cover by turning it counterclockwise with the dedicated tool. ~ Note <i>Remove the front cover straight and with care.</i>
3	Remove the 3 fixing screws.
4	Remove by pulling out.
5	Align the new card's connector to the converter connector. ~ Note <i>Ensure the correct panel direction. The panel attaching direction can be chosen from two options according to the attaching position of this instrument.</i>
6	Fix the card again with the 3 screws. ~ Note <i>The connector is connected firmly by tightening the screws.</i>
7	Attach the front cover. ~ Note <i>Take care not to injure your fingers on the cover edge or the thread in the case.</i>

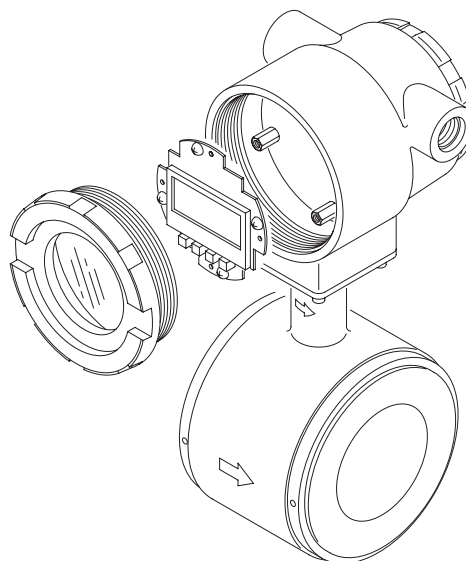

Figure 6-1 Replacement of indicator/data setter (with the cover removed)

6-2 : Troubleshooting

Types of troubles

Introduction

The troubles that can occur when starting up the instrument include the following three types:

- Troubles caused by inconsistencies between the specifications and actual application of the instrument.
- Troubles caused by mistakes in setting or operation
- Troubles caused by failures of the instrument.

The troubles that can occur while running the instrument are divided into major failures and minor failures as described below, and they are recognized, indicated or treated as such by the self-diagnosis function of the instrument.

If trouble should occur, take the appropriate measure referring to the troubleshooting guide described here.

Major failure

A major failure is referred to as a state or failure that causes a grave hindrance to the operation of the instrument and may lead to damage to the instrument itself if left untreated. If major failure occurs while the instrument is running, an error message is displayed on the display panel of the main unit and the output continues to output the value set in the direction of abnormality processing. The error message and self-diagnosis results can be read through communication (SFC, HART[®] communicator).

Minor failure

A minor failure is referred to as a state or failure that does not cause a grave hindrance to the operation of the instrument. If some trouble occurs while the instrument is running but the instrument self-diagnosis it as minor trouble, the output does not become abnormality-processing output and the instrument continues to output the instantaneous flow rate value.

Troubles at startup

Troubleshooting

If trouble should occur at the start of running, maintain according to the following table. If the trouble cannot be solved even if measures are taken according to the following table, the instrument may have broken down. Contact the nearest our customer service offices.

Trouble	Check point and troubleshooting
Nothing is displayed when powered on.	<ul style="list-style-type: none"> • Check the specifications of the power source. • Check the wiring. • Check that the ambient temperature is not under -4°F (-20°C).
No output is sent when powered on.	<ul style="list-style-type: none"> • Check the signal line for correct connection.
Communication impossible.	<ul style="list-style-type: none"> • Check the signal line for correct connection. A load resistance of 250 Ω or more is required (SFC). • Check the communicator for correct connection. (SFC has polarity.) • SFC of Version 7.0 or over is used. Operation is impossible with a lower version. • Is model MTG DD (device description) downloaded on the HART[®] Communicator? The DD for the model MTG should be downloaded from HCF DD Library Host DD Distribution (HCF-KIT-III) Release 2002 Number 3 or later.
Pulse output is not outputted.	<ul style="list-style-type: none"> • Check the counter type, input specifications and contact capacity. • Check the pulse setting of the flowmeter.

Trouble during operation

Troubleshooting

If trouble occurs during operation, maintain in the following procedure.

1. Search for the symptom of the trouble in the table on this page. If found, maintain according to the table.
2. If communication is possible, read the error message and self-diagnosis results. Maintain referring to “Error messages and troubleshooting”.
3. If the above steps cannot solve the trouble, the instrument may have broken down. Contact the nearest our customer service offices.

Trouble	Check point and troubleshooting
The output value fluctuates with a much larger amplitude than the expected variation range of flow rate.	<ul style="list-style-type: none"> • Check that the instrument is grounded correctly. • Check that the damping time constant is set correctly. • Clean the electrodes.
The output value exceeds 100%.	<ul style="list-style-type: none"> • Check that the range is set correctly. • Check that zero is adjusted correctly.
The output value stays at 0%.	<ul style="list-style-type: none"> • Check that the signal line is connected correctly. • Check the upstream and downstream valves. • Check that the range is set correctly. • Isn't the instrument in the constant current mode? • Press the CLR (clear) key on SFC to cancel this mode. • Check that the flow rate is not within the set range of low-flow cutoff. • Check that the flow rate is not reversed (negative flow rate). • Check the detector for unfilled condition, too low conductivity, excessive noise, or the like.
The output is burnt out.	<ul style="list-style-type: none"> • Take measures referring to “Error messages and measures”.
The pulse output is too large or too small for the flow rate.	<ul style="list-style-type: none"> • Is the pulse setting (weight and width) correct? • Is the output from the main unit correct? • Is a pulse counter of appropriate specifications used? • Is the dropout value correctly set between 0 and 10%.

Document Number:	CM2-MTG200-2001
Document Name:	Smart Two-wire Electromagnetic Flowmeter JIS Explosion-protected Apparatus Model: MTG15A User's Manual
Date:	Jul. 2003 (First issue) Jul. 2005 (Rev.1)
Issued/Edited by:	Yamatake Corporation

Yamatake Corporation
Advanced Automation Company

1-1-32 New Stage Yokohama, Shin-urashima-cho,
Kanagawa-ku, Yokohama, Kanagawa-ken 221-0031, Japan
Tel : +81-45-461-8631
Fax : +81-45-461-2658

YAMATAKE
Savemation

Saving through Automation