

**MagneW Neo / MagneW Two-wire PLUS
Smart Two-wire Electromagnetic Flowmeter
Model: MTG11A/18A
MTG11B/18B
MTG14C (Converter)**

User's Manual



Yamatake Corporation

Copyright, Notices and Trademarks

Printed in Japan - ©2002-2005 by Yamatake Corporation All Rights Reserved

While this information is presented in good faith and believed to be accurate, Yamatake Corporation disclaims the implied warranties of merchantability and fitness for a particular purpose and makes no express warranties except as may be stated in its written agreement with and for its customer.

In no event shall Yamatake Corporation be liable to anyone for any indirect, special or consequential damages. This information and specifications in this document are subject to change without notice.

Preface

Thank you for purchasing our smart two-wire electromagnetic flowmeter. The MagneW Neo / MagneW Two-wire PLUS is a landmark electromagnetic flowmeter that is operated on 4-20 mA DC. Based on our extensive experience in the field, meticulous care is taken in the detector lining material and waterproofing properties to secure high reliability.

Unpacking and inspection

Unpacking

This flowmeter is a precision instrument. When unpacking, handle it with care to prevent accident or damage. Check that the following items are contained:

MTG main unit, standard accessories and SETTING DATA sheet

Verifying the specifications

The specifications for this device are written on the nameplate of the main unit. Compare these specifications with those listed in the specification sheets, device standard specifications and model number, and verify that all the specifications on the name plate are correct paying special attention to the following:

(Main unit)

- Detector bore diameter
- Electrode material
- Flange rating
- Grounding ring material

Inquiries

If you have any questions regarding the specifications, contact your local Yamatake representative. When making an inquiry, be sure to provide the MODEL NO. and PRODUCT NO.

Storage precautions

When storing this instrument before use, observe the following instructions:

- Store the device indoors at room temperature and humidity, in a place safe from vibration or shock.
- Store the device in the same condition as it was shipped.

When storing this instrument after usage, observe the following instructions:

1. Rinse the inside of the detector with water to remove any residual fluids and then allow it to dry.
2. Tighten the display cover and terminal box cover in order to prevent moisture ingress.
3. Return the instrument to its original packing.
4. Store the device indoors at room temperature and humidity in a place safe from vibration and shock.

Usage precautions

The following symbols are used in this manual to alert you to possible hazards:

WARNING

Denotes a potentially hazardous situation which if not avoided, could result in death or serious injury.

CAUTION

Denotes a potentially hazardous situation which, if not avoided could result in minor injury or damage to device.

~Note *Denotes important information and guidelines for safety of personnel and protection of device.*

How this Manual is organized and used

Organization and method of use

This manual explains how to use model MTG and related equipment in the following order:

Chapter 1

Explains the configuration of measuring systems using this instrument and describes the names and functions of various parts of the instrument.

Chapter 2

Describes instrument installation. The persons in charge of installation and piping should refer to this chapter.

Chapter 3

Describes the wiring and connections. The persons in charge of wiring work should refer to this chapter.

Chapter 4

Describes the procedure for startup, operation and shut down of this instrument.

Chapter 5

To manipulate the instrument, either its data setting device or a communication line may be used. In this manual, the data setting device is taken up.

Read this chapter when starting the instrument after installation or when stopping its operation.

Chapter 6

Describes the procedures that are necessary for maintenance, inspection and troubleshooting of the instrument.

Use this chapter when searching for an explanation necessary for maintenance or troubleshooting.

Table of Contents

Chapter 1 : Model MTG11A/18A/11B/18B/14C System configuration and structure

	Outline of this chapter.....	1-1
1-1 :	System configuration.....	1-2
	Measuring system.....	1-2
	System configuration for analog output	1-3
	System configuration for analog output and pulse output.....	1-5
	System configuration for analog output and contact output.....	1-6
	System configuration for digital output (DE output)	1-7
1-2 :	Structure of this instrument and functions of its various parts	1-9
	Structure of main unit.....	1-9
	Detector 1: Flanged type	1-11
	Detector 2: Wafer type.....	1-12
	Indicator/data setting device	1-13
	Terminal box.....	1-15
1-3 :	Hazardous area approvals.....	1-17
1-3-1 :	Model MTG18A.....	1-17
	Combination of FM approval and CSA certification for Division 1 and Division 2.....	1-17
1-3-2 :	Models MTG18B and MTG14C	1-19
	FM approval with remote models MTG18B (detector) and MTG14C (converter).....	1-19
	CSA certification with remote models MTG18B (detector) and MTG14C (converter)	1-21

Chapter 2 : Instrument installation

	Outline of this chapter.....	2-1
2-1 :	Before installation	2-2
	Criteria for installation location (1)	2-2
	Criteria for installation location (2)	2-4
	Method of changing the direction of converter.....	2-6
	Changing the direction of display/data setting device.....	2-8
	Movable range of display/data setting device.....	2-9
	Wiring connection distance of remote-type converter and detector.....	2-10
2-2 :	Installation method.....	2-11
2-2-1 :	Installing a wafer type detector	2-11
	Basic installation	2-11
	Accessory parts for installation	2-14
	Selecting an installation method	2-16
	Installation on horizontal pipe	2-17
	Installation on vertical pipe	2-18
	Installation on metal pipe (1).....	2-19
	Installation on metal pipe (2).....	2-20
	Installation on PVC pipe (1)	2-21
	Installation on PVC pipe (2)	2-23
2-2-2 :	Installation a flange type detector	2-25
	Basic installation method	2-25
	Accessory parts for installation	2-28
	Selecting an installation method	2-29
	Installation on metal pipe (1).....	2-30
	Installation on metal pipe (2).....	2-31
	Installation on PVC pipe (1).....	2-32

Table of Contents

Installation on PVC pipe (2)	2-34
2-2-3 : Installation of remote-type converter	2-36

Chapter 3 : Electrical wiring

Outline of this chapter	3-1
3-1 : Electrical wiring	3-2
Electrical wiring	3-2

Chapter 4 : Operation

Outline of this chapter	4-1
4-1 : Confirmation before start-up	4-2
4-2 : Stopping	4-3

Chapter 5 : Operation using the data setting device

5-1 : Startup	5-2
Display and operation contents of data setting device	5-3
5-2 : Functions of the data setting device	5-5
5-2-1 : Data setting device	5-5
5-3 : Description of MEASURING MODE.....	5-7
5-3-1 : Display overview	5-7
5-3-2 : Display of write protect level	5-8
5-4 : Overview of operation using the data setting device	5-10
5-5 : Configuration of OPERATOR'S MODE	5-11
5-5-1 : Changing setting of damping time constant.....	5-13
5-5-2 : Auto zero adjustment.....	5-14
5-5-3 : Setting of built-in counter reset value	5-15
5-5-4 : Setting of built-in counter reset value	5-16
5-5-5 : Setting auto spike cut	5-17
5-5-6 : Setting moving average processing.....	5-18
5-5-7 : Setting empty pipe detection	5-20
Empty pipe detection troubleshooting.....	5-26
5-5-8 : Selecting flow rate to be displayed in the main display	5-27
5-5-9 : Selecting a communication system	5-28
5-5-10 : Entering ENGINEERING MODE and MAINTENANCE MODE	5-30
5-6 : Configuration of ENGINEERING MODE.....	5-32
5-6-1 : Setting ID	5-35
5-6-2 : Selecting pulse output or contact output.....	5-36
5-6-3 : Setting detector information	5-37
5-6-4 : Setting flow rate range.....	5-38
5-6-5 : Setting and changing compensation coefficient	5-39
5-6-6 : Setting specific gravity	5-40
5-6-7 : Setting pulse scale.....	5-41
5-6-8 : Setting pulse width.....	5-43
5-6-9 : Setting drop out	5-46
5-6-10 : Setting low flow cutoff	5-47
5-6-11 : Setting upper and lower limit alarm	5-48

Table of Contents

5-6-12 :	Selecting failsafe mode for analog outputs	5-49
5-6-13 :	Selecting failsafe mode for pulse output.....	5-50
5-6-14 :	Setting contact output status	5-51
5-7 :	Configuration of MAINTENANCE MODE	5-52
5-7-1 :	Configuration of OUTPUT CHECK MODE	5-53
5-7-2 :	Performing loop checks of analog outputs.....	5-54
5-7-3 :	Performing loop checks of pulse outputs.....	5-55
5-7-4 :	Performing loop checks of contact outputs.....	5-56
5-7-5 :	Configuration of CALIBRATION MODE.....	5-57
5-7-6 :	Configuration of CRITICAL MODE	5-60
5-7-7 :	Displaying ROM version and date	5-61
5-7-8 :	Returning to settings at shipment	5-62
5-8 :	Description of Error Messages	5-63

Chapter 6 : Operation using SFC communicator

6-1 :	Structure and functions of SFC	6-1
6-1-1:	Structure of SFC	6-1
	Structure of Smart Field Communicator (SFC).....	6-1
6-1-2:	Functions of SFC	6-3
	SFC keyboard.....	6-3
	Rules of key operations and interaction with screens.....	6-4
	Charging SFC	6-10
6-1-3:	SFC Wiring	6-11
	Wiring between two wired magnetic flowmeter converter and SFC	6-11
6-1-4:	SFC unavailable functions	6-11
6-1-5:	Before operating SFC	6-12
	Status of two wired magnetic flowmeter SFC at SFC communication.....	6-12
	Confirm write protect mode.....	6-12
	Writing on non-volatile memory	6-13
	Changing communication method	6-13
6-2 :	Configuration using SFC communicator	6-14
6-2-1:	Before communicating using the SFC	6-15
	What can be done using the SFC.....	6-15
	Hierarchical structure of CONFIG functions	6-17
	SFC hierarchical structure chart	6-17
	Example of a key sequence.....	6-18
6-2-2:	Setting using SFC communication (1) - setting using key assigned functions	6-19
	Starting communication: ID/DE READ key	6-19
	Entering TAG No.: ID key	6-21
	Setting/changing damping time constant: DAMP key.....	6-23
	Setting engineering units: UNITS key	6-24
	Setting output range and correction coefficient: URV key	6-26
	Displaying transmitting output: OUTPUT key	6-27
	Loop check of output signal	6-28
	Making zero adjustment: CORRECT key	6-29
	Displaying flow rate measured value: INPUT key.....	6-30
	Displaying self-diagnostics result: STAT key.....	6-31
	Error messages and remedial action	6-32
	Displaying software version: SW VER key	6-35
	Data printing	6-36

Table of Contents

	Printing internal data: PRINT key	6-37
	Continuously printing response result: ACT PRINT key	6-39
	Switching between digital output and analog output: A n DE key.....	6-41
6-2-3:	Setting using SFC communication (2) - setting using CONFIG functions	6-42
	Selecting unit system and setting specific gravity [UNIT KEY] function	6-42
	Setting or changing low flow cutoff: [CUT-OFF] function.....	6-44
	Changing flow rate display: [DISP] function.....	6-46
	Setting detector constant: [EX(mA)] function.....	6-48
	Setting detector type: [TYPE] function.....	6-50
	Setting diameter of detector: [DIAMETER=] function	6-52
	Setting high/low alarm values [ALARM CONFIG] function	6-54
	Deciding fail-safe direction: [F/S SET UP] function	6-56
	Setting burnout direction of pulse output: [F/S SETUP] function	6-58
	Select pulse output / contact output [DIGITAL I/O] function	6-60
	Setting contact output status [DIGITAL I/O] function	6-62
	Checking output of contact output: [DI/DO CHECK] function	6-64
	Adjusting analog current output [CORRECT DAC] function	6-66
	Calibrating gain constant [GAIN CAL] function.....	6-68
	Resetting the internal data to factory setting (default) [SHIP DATA RECOV] function.....	6-70
	Displaying totalized value [READ TOTAL] function	6-71
	Checking pulse output [PULSE OUTPUT] function	6-72
	Setting pulse scale and pulse scale unit [PULSE CONFIGURE] function.....	6-74
	Setting pulse width [PULSE CONFIGURE] function.....	6-76
	Setting dropout [PULSE CONFIGURE] function	6-78
	Setting counter reset function [RESET TOTALZE] function	6-80

Chapter 7 : Operation using HART communicator

7-1 :	Preparation for communication, verification and cautions on use	7-1
7-1-1 :	Wiring between converter and HART Communicator	7-1
7-1-2 :	Two wired magflow meter converter setting	7-2
7-1-3 :	Verifying communication.....	7-4
7-1-4 :	Cautions.....	7-4
7-2 :	Setting and calibrating devices using the HART Communicator	7-5
7-2-1 :	Setting procedures.....	7-6
	Flow units.....	7-6
	Range	7-7
	Specific gravity.....	7-7
	Damping time constant.....	7-8
	Zero adjustment.....	7-9
	Selecting display.....	7-10
	Selecting function	7-10
	Correction coefficient setting	7-11
	Changing communication method	7-12
7-2-2 :	Setting converter data.....	7-13
	Detector diameter	7-13
	Detector type	7-13
	Detector constant.....	7-14
7-2-3 :	Signal processing	7-15
	Auto spike cut.....	7-15
	Setting average processing	7-15
	Setting the average processing time	7-16

Table of Contents

	Low flow cutoff	7-16
	Drop-out	7-17
7-2-4 :	Pulse setting	7-18
	Pulse scale unit.....	7-18
	Pulse scale	7-18
	Pulse width	7-19
7-2-5 :	Totalized value setting	7-20
	Displaying totalized value	7-20
	Integrated reset value	7-20
	Resetting the totalized value.....	7-21
7-2-6 :	Contact output setting	7-22
	High alarm value setting	7-22
	Low alarm value setting	7-23
	Contact output status setting	7-23
7-2-7 :	Burnout setting.....	7-24
	Analog output burnout setting.....	7-24
	Pulse output burnout setting	7-24
7-3 :	Calibrating and Inspecting the device by HART Communicator and other functions	7-25
7-3-1 :	Device adjustment	7-25
	Analog current output adjustment.....	7-25
	Gain adjustment.....	7-27
	Pulse output adjustment	7-29
	Excitation current adjustment	7-31
7-3-2 :	Output check.....	7-33
	Analog output check	7-33
	Pulse output check	7-34
	Contact output check	7-35
7-3-3 :	Other functions	7-36
	Verifying status of converter	7-36
	Tag setting.....	7-37
	Shipping data recovery	7-37
	Review	7-38
7-4 :	Short cut commands and menus for HART communicator	7-39
7-4-1 :	Short cut keys	7-39
7-4-2 :	Menu tree.....	7-40
 Chapter 8 : Maintenance and troubleshooting		
	Outline of this chapter.....	8-1
8-1 :	Maintenance and inspection of parts	8-2
	Replacement of indicator / data setting device	8-2
8-2 :	Troubleshooting	8-3
	Types of troubles	8-3
	Troubles at startup	8-4
	Troubles during operation.....	8-5
8-3 :	Spare parts.....	8-6
8-3-1:	Spare parts for integral type	8-6
8-3-2:	Spare parts for remote type converter	8-8
8-3-3:	Spare parts for remote type detector	8-10

Table of Contents

Table of Contents

List of Figures & Tables

<Figures>

Figure 1-1	Conceptual drawing of measuring system (integral type).....	1-2
Figure 1-2-1	System configuration for analog output 1 (Integral type).....	1-3
Figure 1-2-2	System configuration for analog output 1 (Remote type).....	1-3
Figure 1-3-1	System configuration for analog output 2 (Integral type).....	1-5
Figure 1-3-2	System configuration for analog output (Remote type).....	1-5
Figure 1-4-1	System configuration for analog output 1 (Integral type).....	1-6
Figure 1-4-2	System configuration for analog output 2 (Remote type).....	1-6
Figure 1-5-1	System configuration for digital output.....	1-7
Figure 1-5-2	System configuration for digital output.....	1-8
Figure 1-6-1	Overview of integral type.....	1-9
Figure 1-6-2	Overview of remote type.....	1-10
Figure 1-7	Detector details (Flanged detector).....	1-11
Figure 1-8	Detector details (wafer-type detector).....	1-12
Figure 1-9	Indicator/data setting device details.....	1-13
Figure 1-10	Display.....	1-14
Figure 1-11	Terminal box details.....	1-15
Figure 1-12-1	Terminal block (integral type).....	1-15
Figure 1-12-2	Terminal block (remote type).....	1-15
Figure 1-13	Process fluid temperature and pressure limit for model MTG18A.....	1-18
Figure 1-14	Process fluid temperature and pressure limit for model MTG18B.....	1-21
Figure 2-1	Example of installation.....	2-4
Figure 2-2	Straight pipe section upstream of detector (D: Nominal detector bore diameter).....	2-4
Figure 2-3	Maintenance space.....	2-5
Figure 2-4	Change the direction of converter.....	2-6
Figure 2-5	Changing the display / data setting device direction.....	2-8
Figure 2-6	Movable range of display/data setting device.....	2-9
Figure 2-7	Cable length (m) between converter and detector.....	2-10
Figure 2-8	Cable length (m) between converter and detector.....	2-10
Figure 2-9	Device installation example.....	2-11
Figure 2-10	Flange shape.....	2-12
Figure 2-11	Examples of unacceptable installations (1).....	2-13
Figure 2-12	Examples of unacceptable installations (2).....	2-13
Figure 2-13	Horizontal centering of the detector.....	2-14
Figure 2-14	Vertical centering of the detector.....	2-14
Figure 2-15	Installation using SUS material grounding ring and metal pipe.....	2-19
Figure 2-16	Installation using Non-SUS material grounding ring and metal pipe.....	2-20
Figure 2-17	Example of incorrect installation.....	2-20
Figure 2-18	Installation using SUS material grounding ring.....	2-21
Figure 2-19	Installation using SUS material grounding ring (with protective plate).....	2-22
Figure 2-20	Installation using SUS material grounding ring (with rubber gasket).....	2-22
Figure 2-21	Installation using Non-SUS material grounding ring.....	2-23
Figure 2-22	Installation using Non-SUS grounding ring (with protective plate).....	2-24
Figure 2-23	Installation using Non-SUS grounding ring (with rubber gasket).....	2-24
Figure 2-24	Installation example.....	2-25

List of Figures & Tables

Figure 2-25	Flange shape	2-27
Figure 2-26	Example of incorrect mounting	2-27
Figure 2-27	Installation using SUS material grounding rings	2-30
Figure 2-28	Installation using Non-SUS material grounding ring	2-31
Figure 2-29	Example of incorrect installation	2-31
Figure 2-30	Installation using SUS material grounding ring	2-32
Figure 2-31	Installation using SUS material grounding ring (with protective plate)	2-33
Figure 2-32	Installation using SUS material grounding ring (with rubber gasket)	2-33
Figure 2-33	Installation using Non-SUS material grounding ring	2-34
Figure 2-34	Installation using Non-SUS material grounding ring (with protective plate)	2-35
Figure 2-35	Installation using Non-SUS material grounding ring (with rubber gasket)	2-35
Figure 2-36	Wall mounting	2-36
Figure 2-37	2-inch pipe mounting	2-36
Figure 3-1-1	Supply power voltage-load resistance characteristics	3-3
Figure 3-1-2	Terminal block - Integral type	3-3
Figure 3-1-3	Terminal block - Remote type	3-4
Figure 3-2	Grounding procedure that uses internal grounding terminal	3-6
Figure 3-3	Grounding procedure that uses external grounding terminal	3-6
Figure 3-4	Wire connection diagram	3-7
Figure 3-5	Wire connection diagram (When inputting to the sequence controller etc.)	3-7
Figure 3-6	Pulse output wire connection diagram	3-8
Figure 3-7	Contact output wire connection diagram	3-8
Figure 3-8	Wiring for power supply - Integral type	3-10
Figure 3-9	Wiring for power supply - Remote type	3-10
Figure 3-10	Wiring connection between detector and converter	3-10
Figure 5-1	Damping output characteristics	5-13
Figure 5-2	Auto spike cut output characteristics	5-17
Figure 5-3	Output characteristics of moving average processing	5-18
Figure 6-1	Details of SFC	6-1
Figure 6-3	SFC wiring connection	6-11
Figure 6-4	Data setting screen	6-13
Figure 8-1	Replacement of indicator/data setting device (with the cover removed)	8-2
Figure 8-2	Spare parts for integral type	8-6
Figure 8-3	Spare parts for remote type converter	8-8
Figure 8-4	Spare parts for remote type detector	8-10

List of Figures & Tables

<Tables>

Table 2-1	Fastening torque	2-12
Table 2-2	Recommended internal diameters of gaskets	2-15
Table 2-3	Internal and external diameters of rubber gaskets (0.5 to 1 mm thick)	2-15
Table 2-4	Internal and external diameter of rubber gaskets (3 to 4 mm thick)	2-15
Table 2-5	Fastening torque	2-26
Table 2-6	Recommended internal diameters of gaskets	2-28
Table 6-1	Spare parts for integral type	6-7
Table 6-2	Spare parts for remote-type converter (Model MTG11B)	6-9
Table 6-3	Spare parts for remote-type detector (Mode MTG11B)	6-10
Table 6-4	Wafer type grounding ring assembly	6-11
Table 6-5	Flange type grounding ring assembly	6-13
Table 6-6	Through bolt and nut (required 1 set per detector)	6-15
Table 6-7	Centering tool for wafer type detector (required 4 pcs. per detector)	6-17

Chapter 1 : Model MTG11A/18A/11B/18B/14C

System configuration and structure

Outline of this chapter

This chapter presents the equipment configuration of a measuring system using this instrument.

It also describes the structure and the names and functions of various parts of the main unit.

1-1 : System configuration

Measuring system

Introduction

This instrument is a two-wire electromagnetic flowmeter which operates on the 4-20 mA DC. It measures the flow rate of the conductive fluid flowing in the detector and outputs a signal that is suitable for the measuring range.

Concept of flow rate measurement by this instrument

The concept of a flow rate measuring system using this instrument is shown.

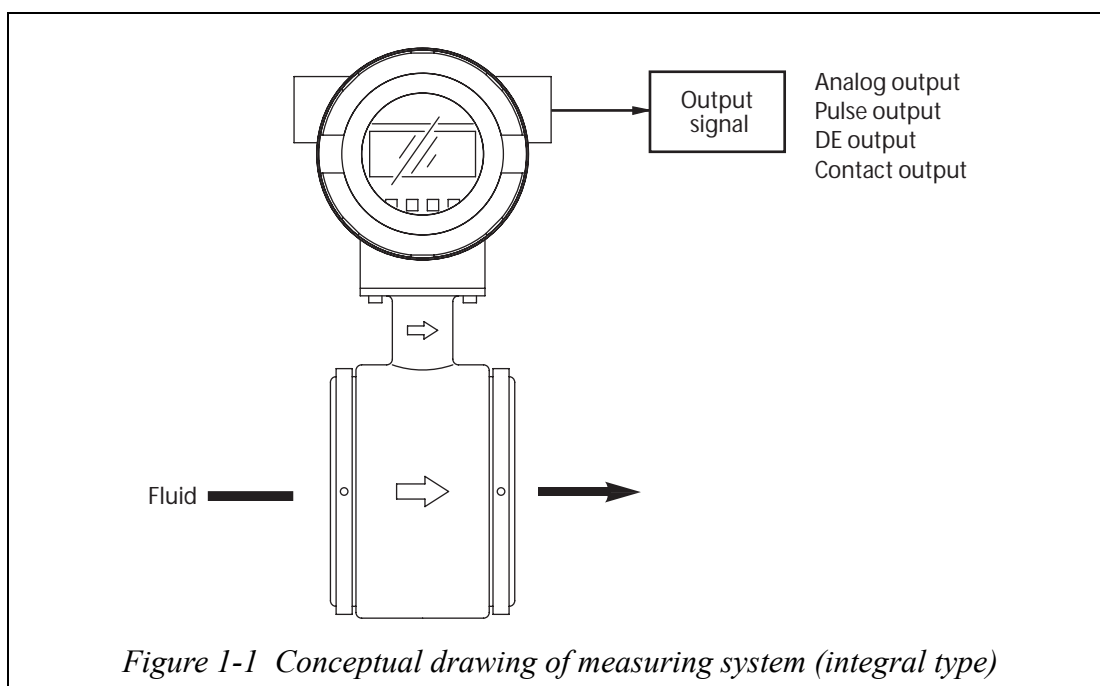

Analog output

If the instantaneous flow rate values are to be output as an analog variable to the control equipment, configure the system to output an analog output.

Digital output (DE output)

Use this system configuration if the instantaneous flow rate values, instrument database and self-diagnosis results are to be output as digital variables (DE outputs) to the control equipment.

Pulse output

As a pulse output, the open-collector output is available. Pulse frequencies up to 200 Hz can be output. The pulse output can be output simultaneously with an analog output.

If the integrated flow values are to be output as a pulse to control equipment, wire an another two-wire to output a pulse output.

Contact output

Instead of the pulse output, a contact output the open-collector output is available. The contact output can be output simultaneously with an analog output.

System configuration for analog output

System configuration

An example of system configuration is shown. The instantaneous flow rate values measured by this instrument are output as a 4-20 mA DC analog signal.

In this system configuration, the analog signal from the instrument can be output directly to a host control system.

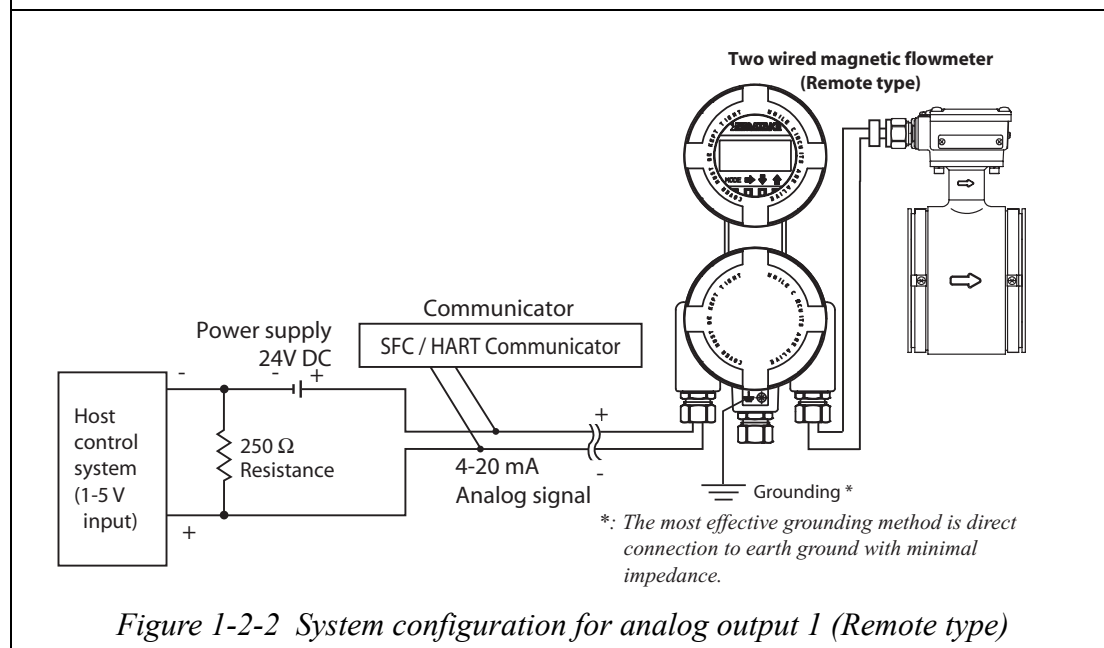
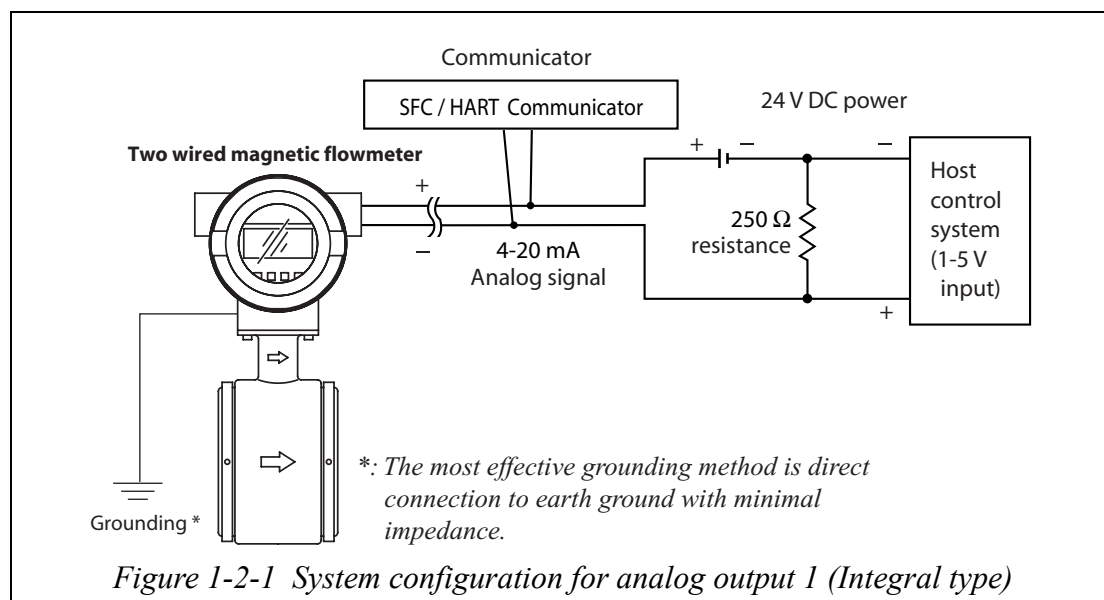

- Two wired magnetic flowmeter: Measures flow rate and outputs instantaneous flow rate value as an analog signal.
- Communicator: Used to communicate with this instrument, read data and change the instrument data settings.

- ~Note**
- *To use the SFC, read “Chapter 6 : Operation using SFC communicator” in this manual.*
 - *To use the HART communicator, read “Chapter 7 : Operation using HART communicator” in this manual.*
 - *Compatible with the SFC of Ver 7.0 or higher. However, some functions on the main unit cannot be set.*
 - *For DD (device description) of the HART Communicator, use the HCF DD Library Host DD Distribution (HCF-KIT-III) Release 2002 Number 3 or later.*
 - *This instrument can communicate on two protocols: Smart Field Communication (SFC) and HART communication (HART communicator). The communication method to be used is selected by the (human) data setting device.*

When configuring a system using this instrument, it is necessary to determine the power supply voltage and load resistance to satisfy the operation conditions of this instrument.

System configuration for analog output and pulse output

System configuration

An example of the system configuration is shown.

The flow rate is available as an analog 4-20 mA DC output and totalized value is available as a pulse output.

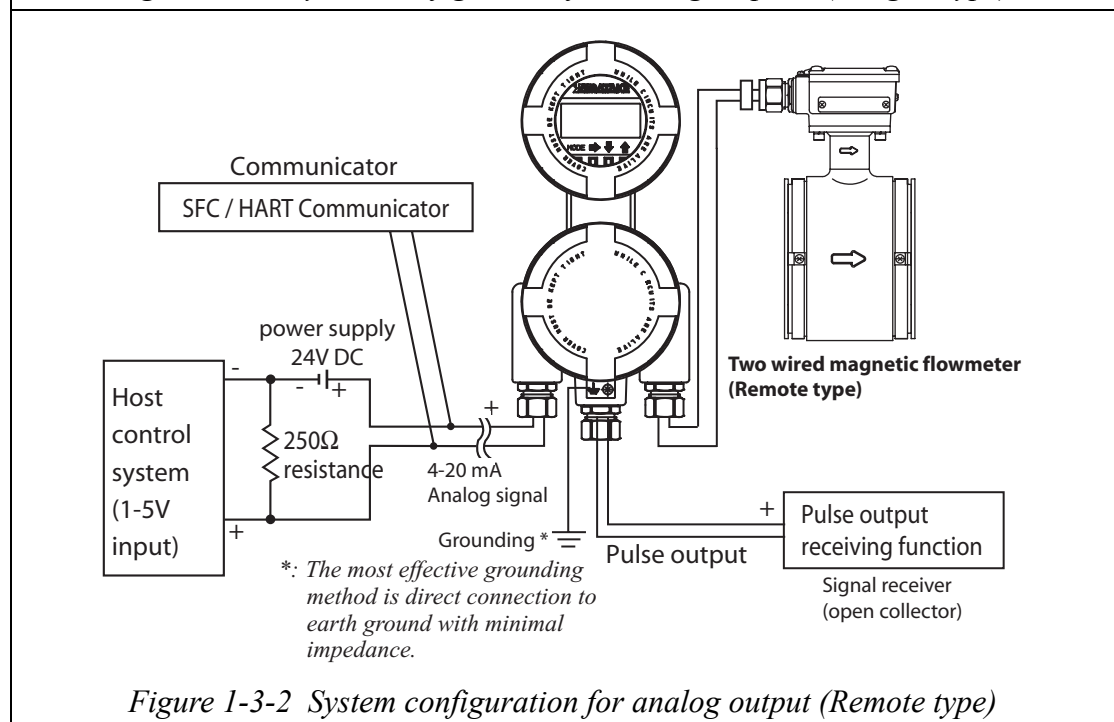
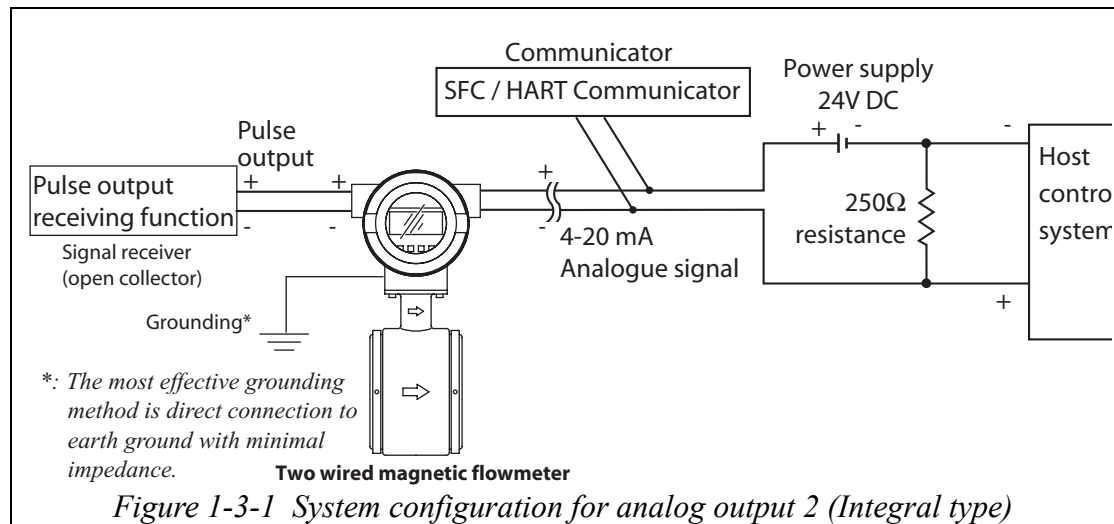

- Two wired magnetic flowmeter: Measures flow rate and outputs the instantaneous flow rate value as an analog signal.
- Communicator: Used to communicate with this instrument, read data and change the instrument data settings.
- Pulse output receiver equipment: It inputs the pulse output, and displays the totalized value.

~Note *Open collector: It is pulse output method to use the transistor contact.*

System configuration for analog output and contact output

System configuration

In the system configuration shown below, the instantaneous flow rate is output as 4-20 mA analog signal and alarm is output when the status output is configured for the alarm function. As an alarm, self diagnosis output (critical failure) or upper/lower limit alarm is output.

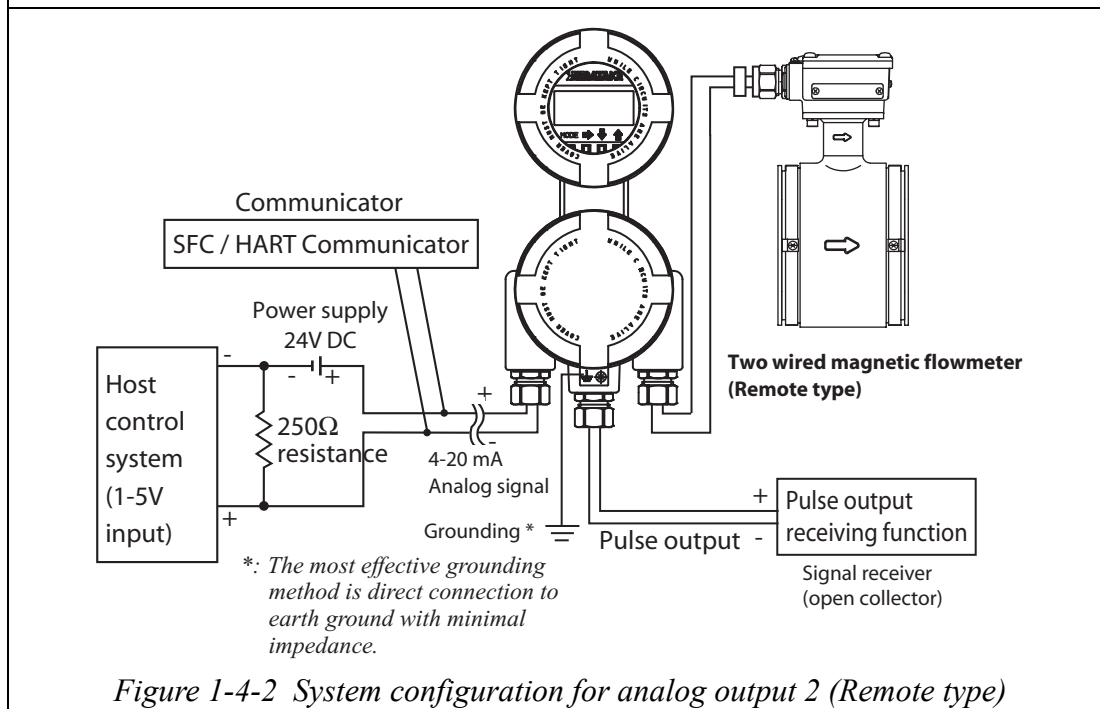
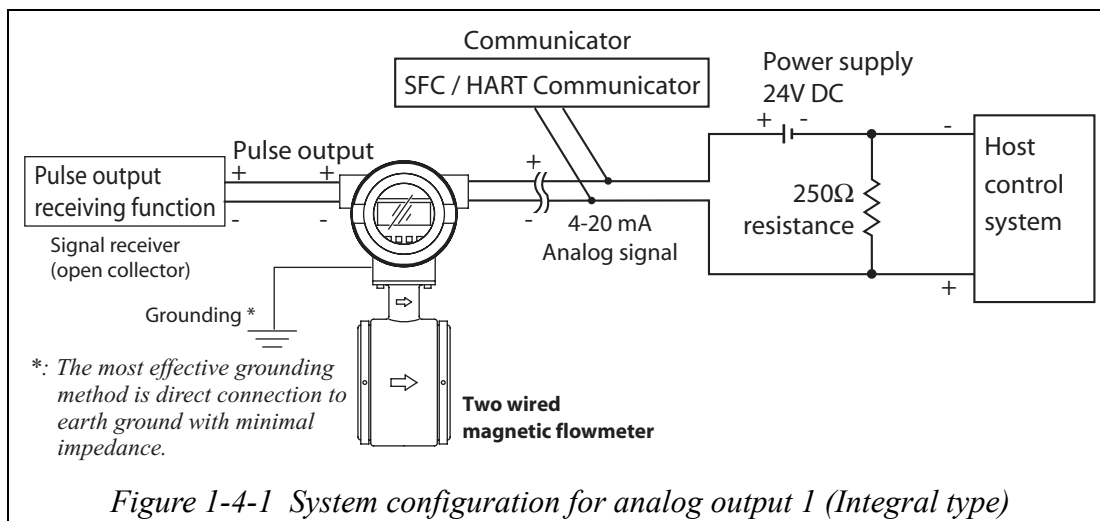

- Two wired magnetic flowmeter: Measures flow rate and outputs the instantaneous flow rate value as an analog signal.
- Communicator: Used to communicate with this instrument, read data and change the instrument data settings.
- Pulse output receiver equipment: It receiver the pulse output, and displays the totalized value.

~Note *Open collector: pulse output method using the transistor contact.*

System configuration for digital output (DE output)

System configuration

In the system configuration shown below, the flow rate measurements, database and self-diagnosis results of this instrument are output on the DE (digital enhanced) protocol, which is a communication protocol for digital signals.

When it uses the pulse output or the contact output together and, the wiring of the flowmeter pulse output and the contact output are same as mentioned is the “System configuration” on page 1-5 and page 1-6.

In this system configuration, the instrument transmits digital signals on the DE protocol and the smart protocol converter (SPC) converts the digital signals into analog signals, which is output to a control system. It can also output the DE protocol based digital signals without the conversion to a control system.

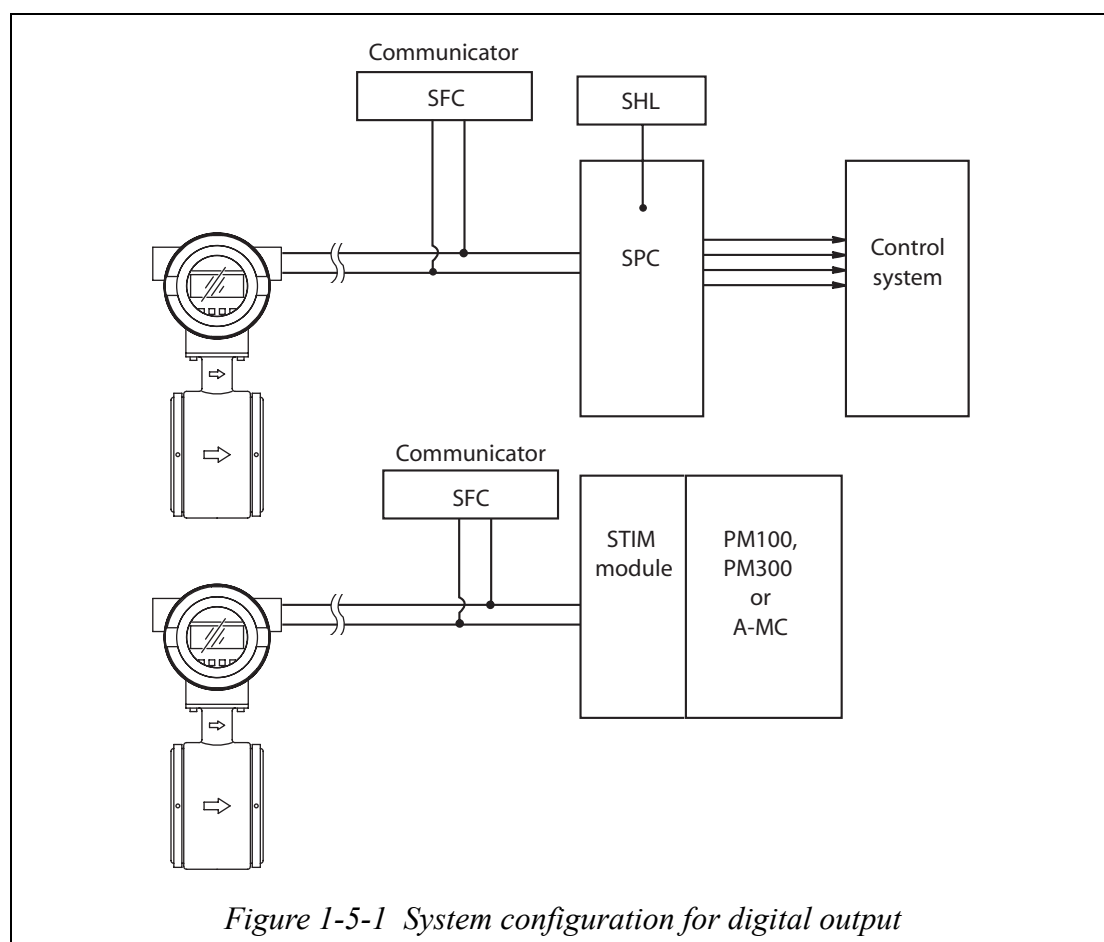
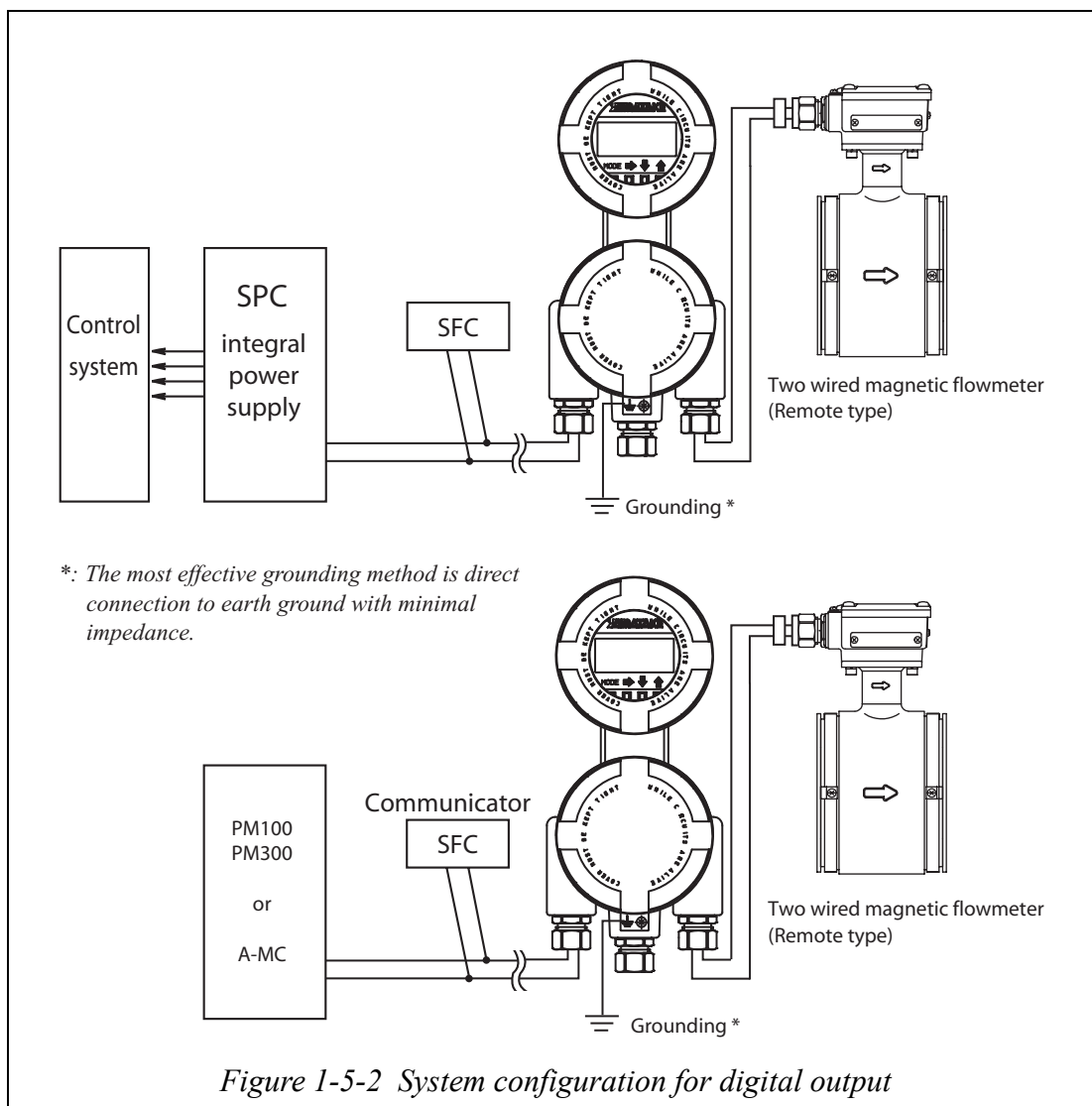

Figure 1-5-1 System configuration for digital output



- Two wired magnetic flowmeter: Measures flow rate and outputs the instantaneous flow rate values and the instrument's self-diagnosis results in the form of digital signals.
- Smart protocol converter (SPC): Receives DE protocol based digital signals from this instrument and converts them and outputs into a 4-20 mA DC or 1-5V DC analog signal.
- Communicator (SFC): Used to communicate with this instrument, read data and change instrument data settings.
- PM100, PM300, A-MC: These are process controllers on the UCN which carries out the regulatory control, sequences, arithmetic operations, process I/O and other functions simultaneously.

1-2 : Structure of this instrument and functions of its various parts

Structure of main unit

Major components

This instrument consists of a detector and converter. The converter, consists of the converter proper, indicator/data setting device and terminal box. Figure 1-6-1 shows overview of the instrument. (For detailed specification and outline drawing, refer to SS2-MTG100-0100)

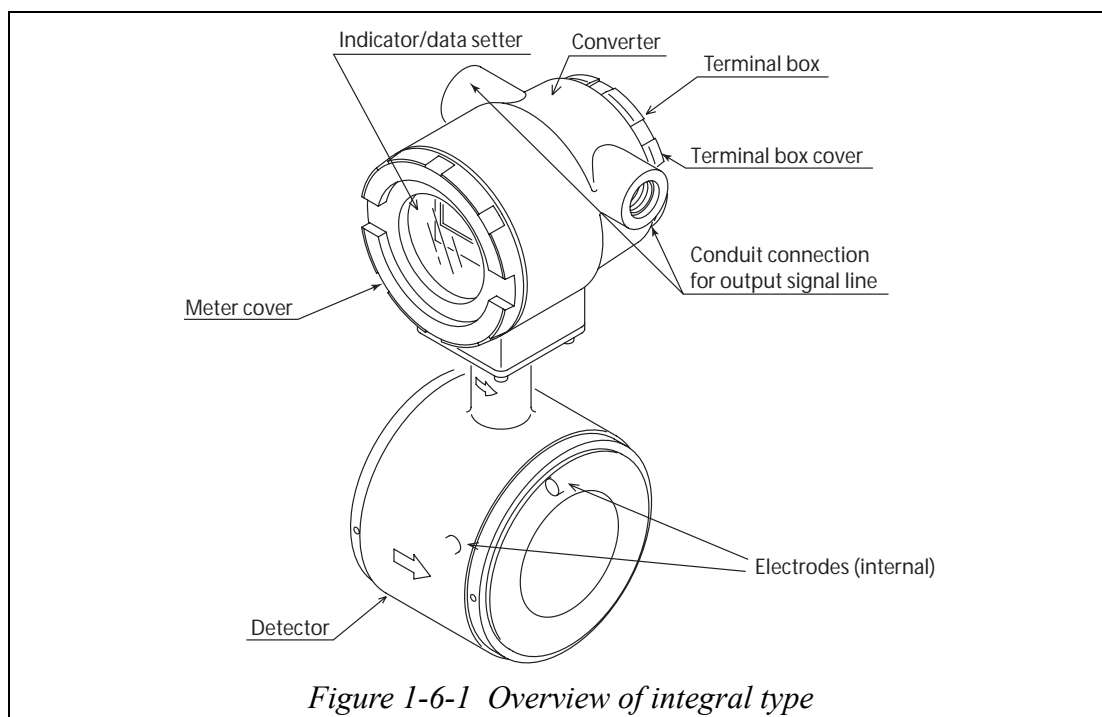

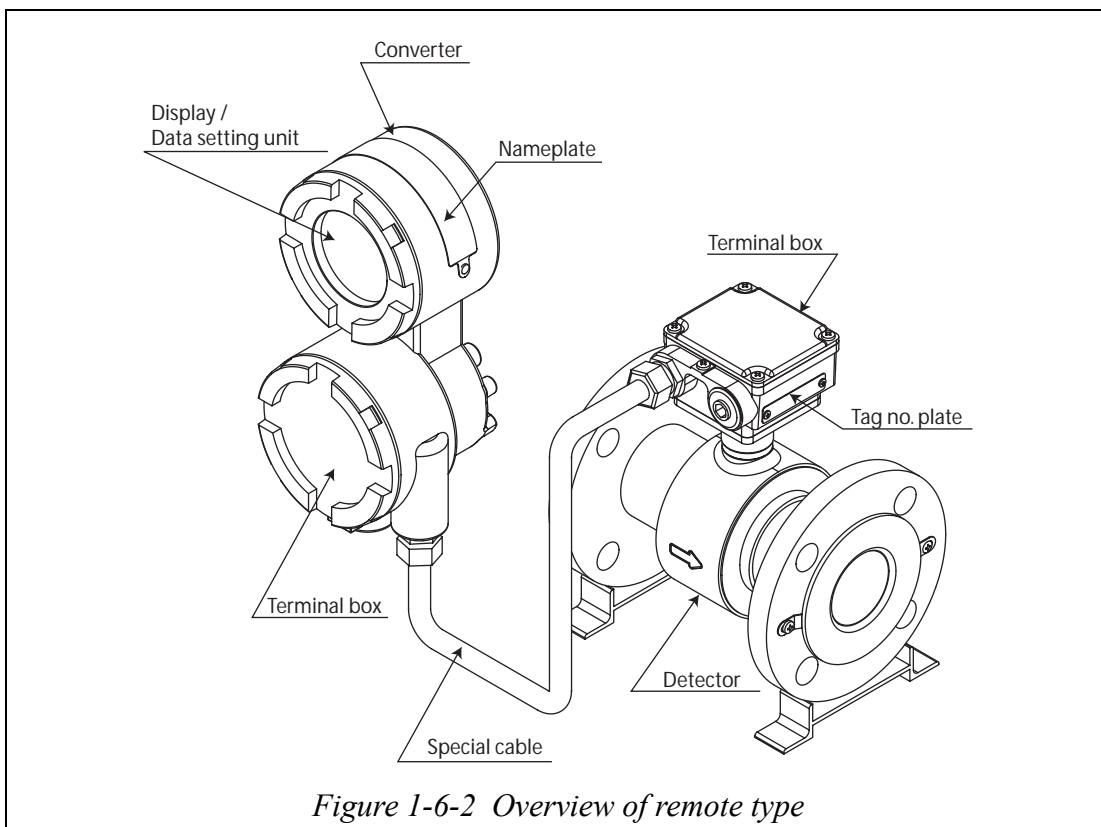

Figure I-6-2 Overview of remote type

Names and description of various parts

The following table gives a description of the various parts.

Name	Description
Detector	<ul style="list-style-type: none"> • When a fluid passes through the inside, the detector generates a signal of electromotive force that is proportional to the flow rate of the passing fluid. • Connects to the pipes and supports the entire instrument. • Hoses the electrodes, both electrodes are installed in a horizontal position.
Converter	<ul style="list-style-type: none"> • Converts the signal of electromotive force generated by the detector into an instantaneous flow rate value and outputs it as a flow rate signal.
Special cable	<ul style="list-style-type: none"> • It transmits the electromotive force and the excitation current generated by the detector. • The shielded special cable offers strong protection against electromagnetic interferences and environment influences.
Display panel	<ul style="list-style-type: none"> • It displays the instantaneous flow rate value and the internal state of this flowmeter.
Terminal box	<ul style="list-style-type: none"> • Contains output signal and grounding terminals.
Nameplate	<ul style="list-style-type: none"> • MODEL No., PRODUCT No. and detector constant (EX) are written.
TAG No. plate	<ul style="list-style-type: none"> • TAG No. is written according to the order specification.

Detector 1: Flanged type

Description

The flanged detector has the function and structure as follows:

- Detects an electromagnetic force signal proportional to the flow rate of the fluid passing through the detector.
- Installs to the pipes and supports the entire instrument.
- Houses the electrodes, both electrodes are installed in a horizontal position.

Names of various parts

The structure and names of various parts of the detector are shown.

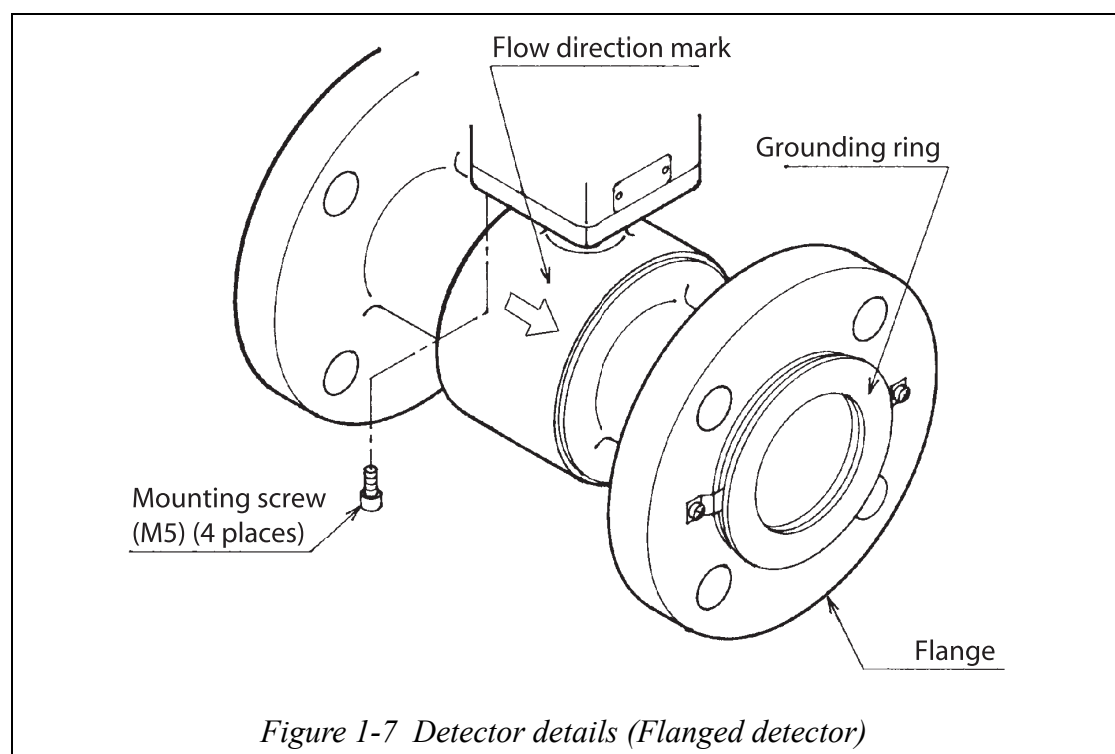

Names and functions of various parts

The following table describes the various parts of the detector.

Name	Description
Flow direction mark	<ul style="list-style-type: none"> • Indicates the flow direction of the fluid. • Attach the detector so that the direction of fluid flow and this mark agree with each other.
Grounding ring	<ul style="list-style-type: none"> • Keeps reference voltage to zero by grounding the unit. The grounding ring material varies depending on the corrosion characteristics of the fluid to be measured.
Mounting screw (M5)	<ul style="list-style-type: none"> • Fixes the detector to the converter. • When these screws are removed, the detector and the converter orientation can be changed.
Flange	The flanges depend on the flanges on the pipes to which to connect.

Detector 2: Wafer type

Description

The wafer type detector has a function and structure as follows:

- Detects an electromagnetic force signal proportional to the flow rate of the fluid passing through the detector.
- Houses the electrodes, both electrodes are installed in a horizontal position.

Names of various parts

The structure and names of various parts of the detector are shown.

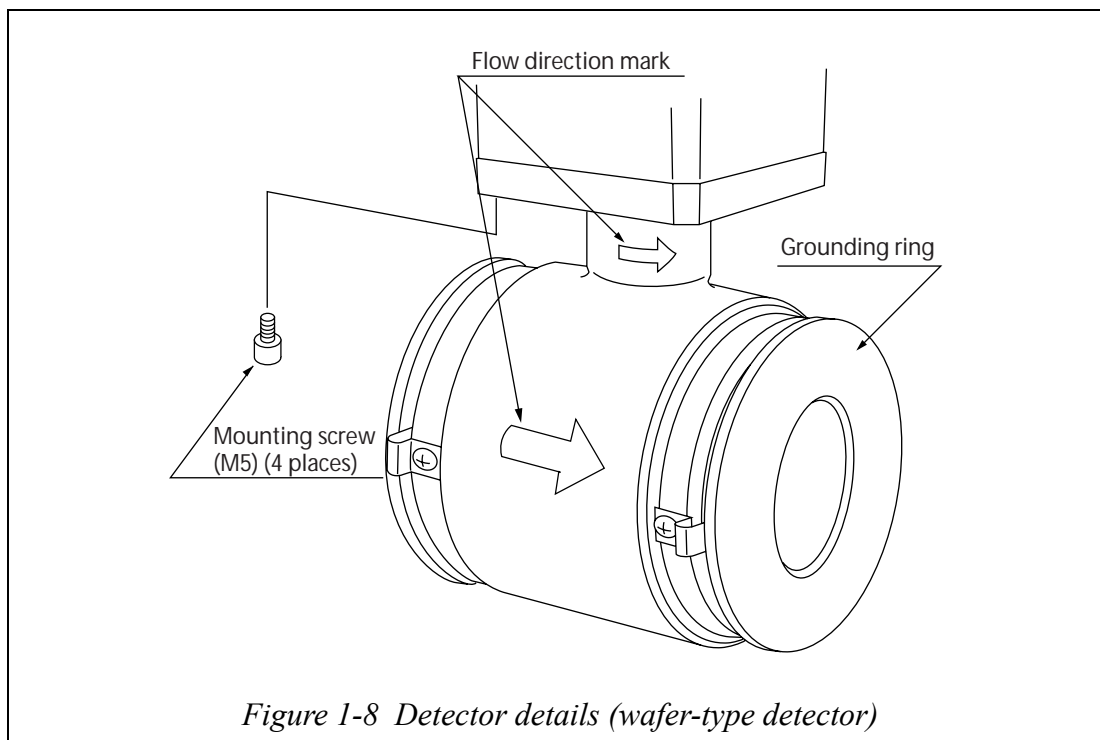

Names and functions of various parts

The following table describes the various parts of the detector.

Name	Description
Flow direction mark	<ul style="list-style-type: none"> • Indicates the flow direction of the fluid. • Install the detector so that the direction of fluid flow and this mark meet with each other.
Grounding ring	<ul style="list-style-type: none"> • Keeps reference voltage to zero by grounding the unit. The grounding ring material varies depending on the corrosion characteristics of the fluid to be measured.
Mounting screw (M5)	<ul style="list-style-type: none"> • Fixes the detector and converter. • When these screws are removed, the detector and the converter orientation can be changed.

Indicator/data setting device

Description

The indicator/data setting device has the following function and structure.

- Displays the instantaneous flow rate value and internal conditions of the instrument.
- The indicator face can be turned at intervals of 90 degrees through one turn.
- Refer to “ Changing the direction of display/data setting device” on page 2-8.

Names of various parts

The names of various parts of the indicator/data setting device are shown.

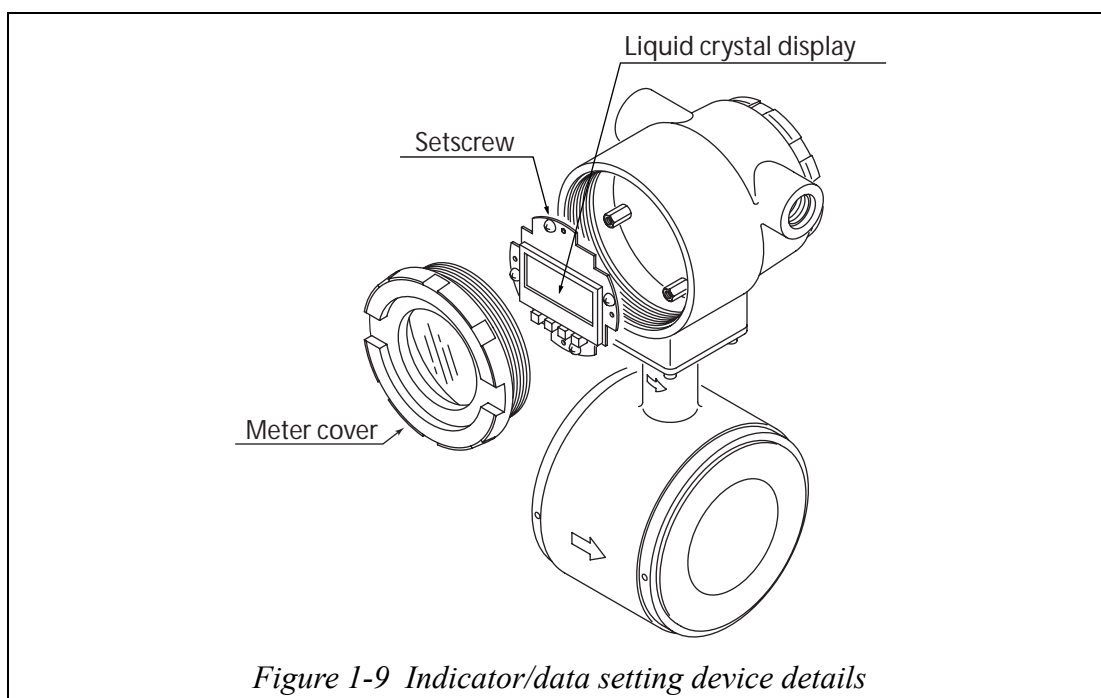

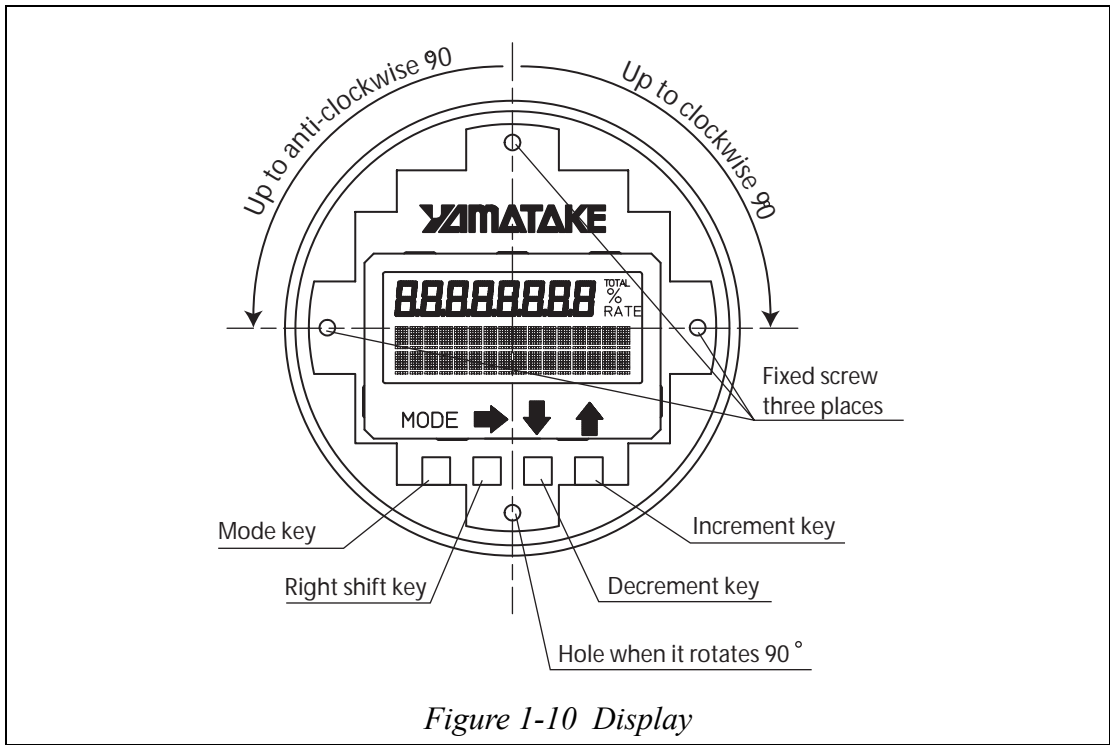

Terminal box

Description

The terminal box houses the output signal terminals.

Names of various parts

Figure 1-10 shows the structure and names of various parts of the terminal box.

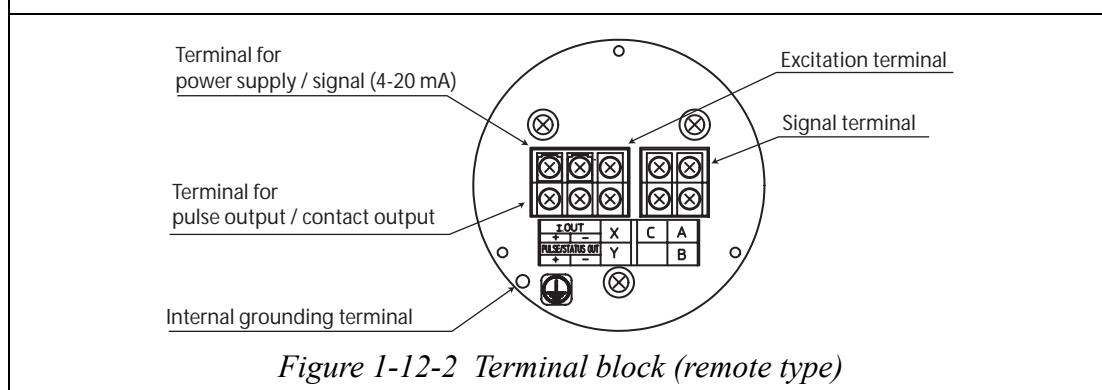
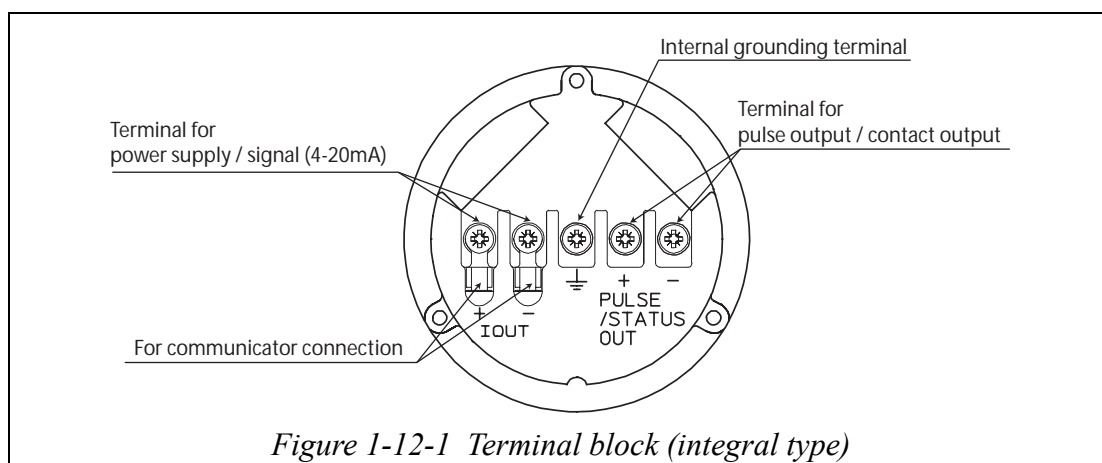
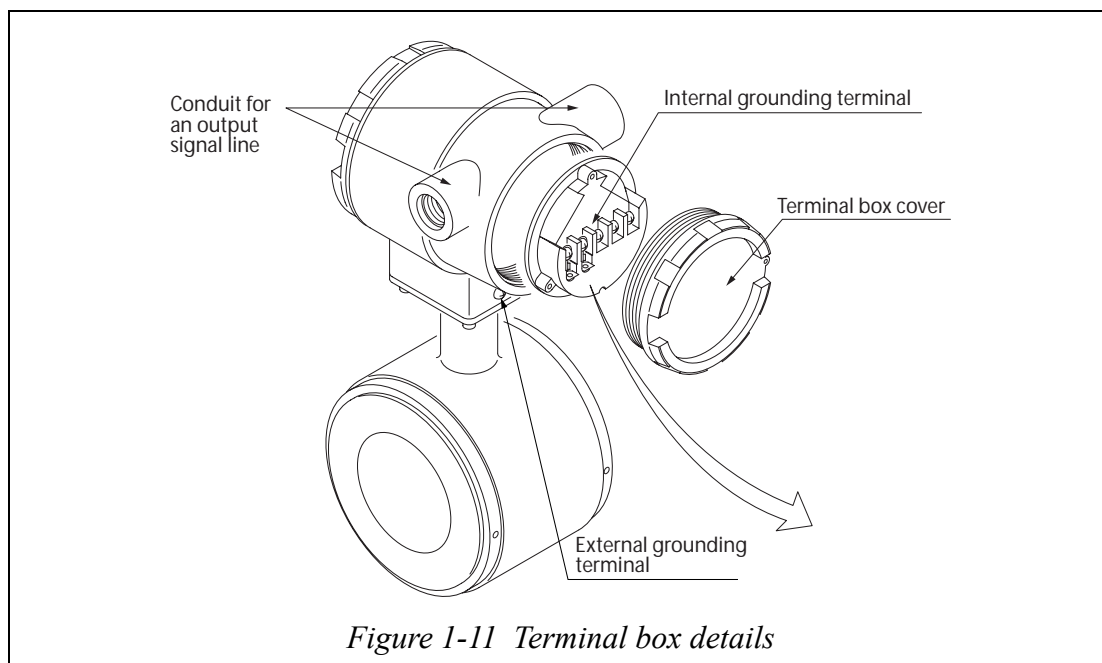

Names and description of various parts

The following table describes the various parts of the terminal box.

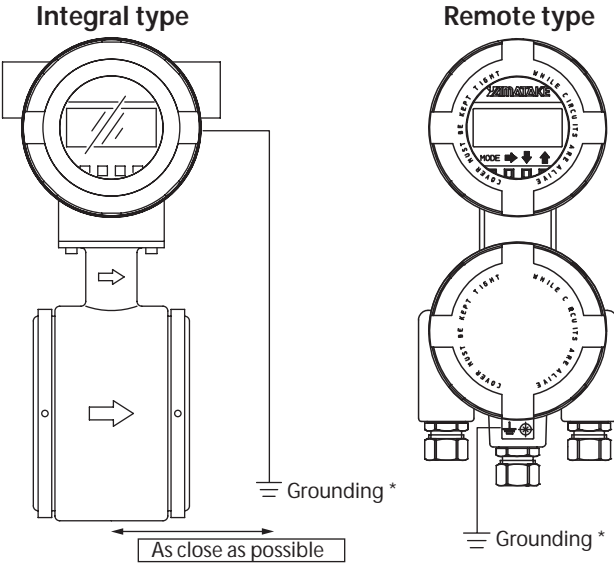
Name	Description
Power supply / Output signal terminal	<ul style="list-style-type: none"> • I.OUT+, -: Analog current output and DC power supply terminals
Pulse / Contact output	<ul style="list-style-type: none"> • PULSE/STATUS OUT+, -: Open-collector pulse output and contact output terminals
External grounding terminal	<ul style="list-style-type: none"> • Make a one-point grounding at a place as close to this instrument as possible. • The grounding is essential for flow measurement. Improper grounding can cause malfunctions. <div style="text-align: center;">  <p style="text-align: center;">*: The most effective grounding method is direct connection to earth ground with minimal impedance.</p> </div>
Internal grounding terminal	<ul style="list-style-type: none"> • If susceptible to noise (during communication), connect one end of the shielded wire to this terminal (Do not connect in normal cases). • Connected inside to the external grounding terminal. When using, take care not to make a two-point grounding.
Output signal line conduit	<ul style="list-style-type: none"> • Wire the signal line through this port. • Comes with a plastic dust cover if a type number without a waterproof gland is selected. However, it has no waterproof capability. The customer should provide a waterproof gland.

1-3 : Hazardous area approvals

1-3-1 : Model MTG18A

Combination of FM approval and CSA certification for Division 1 and Division 2

Approval selection code "1"

FM approval

Protection codes

- Explosionproof with intrinsically safe electrodes for Class I, Division 1, Groups A, B, C and D, T4;
 - Dustignitionproof for Class II and III, Division 1, Groups E, F and G, T4;
- at $-20^{\circ}\text{C} \leq T_{\text{amb}} \leq +60^{\circ}\text{C}$
Enclosure rating; Type 4X and IP67

Cautions

- Seal not required
- Electrode circuit is Intrinsically Safe
- Substitution of components may impair Intrinsic Safety
- Control room equipment shall not use or generate in excess of 250Vr.m.s. or DC

Installation

The equipment shall be installed in accordance with the relevant requirements of the National Electrical Code (ANSI/NFPA70).

Grounding

To maintain Intrinsic safety of system connect conductor to earth ground so that it has less than one ohm (1Ω) to earth ground.

See ANSI/ISA PR12.06.01 Installation of Intrinsically Safe System for Hazardous (Classified) Locations for guidance on installation of intrinsically safe apparatus and systems.

CSA certification

Protection codes

- Class I, Division 1, Groups A, B, C, D; Class II, Division 1, Groups E, F, G; Class III:
- Input rating 42V dc, 4-20mA. Provides intrinsically safe output to detector sensing electrodes. Enclosure Type 4X/IP67. MWP 3.0 MPa max. Temperature Code T4, $T_a = -20^{\circ}\text{C}$ to $+60^{\circ}\text{C}$

Cautions

- Seal not required
- Cover must be kept tight while circuits are alive
- Warning: Substitution of components may impair intrinsic safety

Installation

The equipment shall be installed in accordance with the relevant requirements of the Canadian Electrical Code, Part I.

Approval selection code “2”

FM approval

Protection codes

- Nonincendive for Class I, Division 2, Groups A, B, C and D, T4;
 - Nonincendive for Class I, Zone 2, Group IIC, T4;
 - Suitable for Class II and III, Division 2, Groups F and G, T4
- at $-20^{\circ}\text{C} \leq T_{\text{amb}} \leq +60^{\circ}\text{C}$

Enclosure rating; Type 4X and IP67

Cautions

Control room equipment shall not use or generate in excess of 250Vr.m.s. or DC

Installation

The equipment shall be installed in accordance with the relevant requirements of the National Electrical Code (ANSI/NFPA70).

CSA certification

Protection codes

- Class I, Division 2, Groups A, B, C and D; Class II, Division 2, Groups E, F, G; Class III:

Input rating 42V dc, 4-20mA. Provides Non-Incendive circuit to sensing electrodes. Enclosure Type 4X/IP67. MWP 3.0 MPa max. Temperature Code T4, $T_a = -20^{\circ}\text{C}$ to $+60^{\circ}\text{C}$

Cautions

- Warning: Explosion Hazard - Substitution of components may impair suitability for Class I, Division 2

Installation

The equipment shall be installed in accordance with the relevant requirements of the Canadian Electrical Code, Part I.

Process fluid temperature and pressure limit for model MTG18A

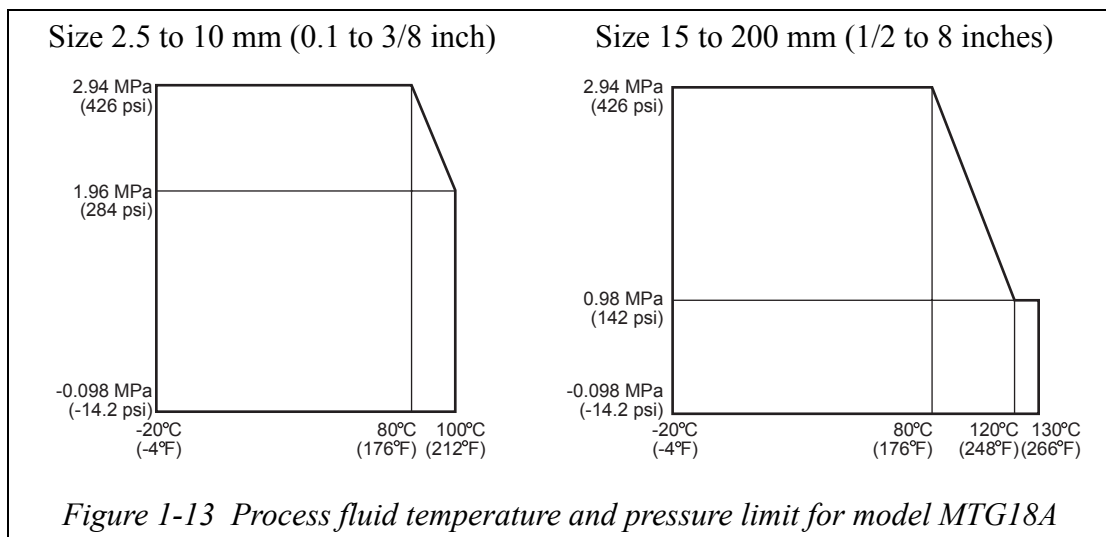

1-3-2 : Models MTG18B and MTG14C

FM approval with remote models MTG18B (detector) and MTG14C (converter)

Approval selection code “2”

Protection Codes

Model MTG18B:

- Nonincendive for Class I, Division 2, Groups A, B, C and D, T4; Suitable for Class II, Division 2, Groups F and G, Class III, T4; Ta = 60°C; Control drawing 80391906; Type 4X, IP67
- Nonincendive for Class I, Zone 2, IIC, T4 Ta = 60°C; Control drawing 80391906; Type 4X, IP67

Model MTG14C:

- Nonincendive for Class I, Division 2, Groups A, B, C and D, T4; Suitable for Class II, Division 2, Groups F and G, Class III, T4; Ta = 60°C; Control drawing 80391906; Nonincendive Field Wiring; Type 4X, IP67
- Nonincendive for Class I, Zone 2, IIC, T4 Ta = 60°C; Control drawing 80391906; Nonincendive Field Wiring; Type 4X, IP67
- Nonincendive Field Wiring Parameters:

<u>Terminals</u>	<u>V_{max}</u>	<u>I_{max}</u>	<u>C_i</u>	<u>L_i</u>
Iout+, Iout-	42V	22 mA	0.016 μF	0
Pulse/Status out +, Pulse/Status out -	30V	100 mA	0	0

Special condition of use

Model MTG18B:

- The model MTG18B shall be installed in compliance with the enclosure, mounting, spacing and segregation requirements of the ultimate application including access only by the use of tool.
- The process liquid flowing through the model MTG18B must be non-flammable.

Model MTG14C:

- The model MTG14C shall be installed in compliance with the enclosure, mounting, spacing and segregation requirements of the ultimate application including access only by the use of tool.
- The model MTG14C may only be used with the model MTG18B.

Installation

- Installations shall comply with the relevant requirements of the Nation Electrical Code (ANSI/NFPA70).
- Regarding the detailed equipment enclosure requirements, refer to the ANSI/ISA S82.01 or other applicable ordinary location standards

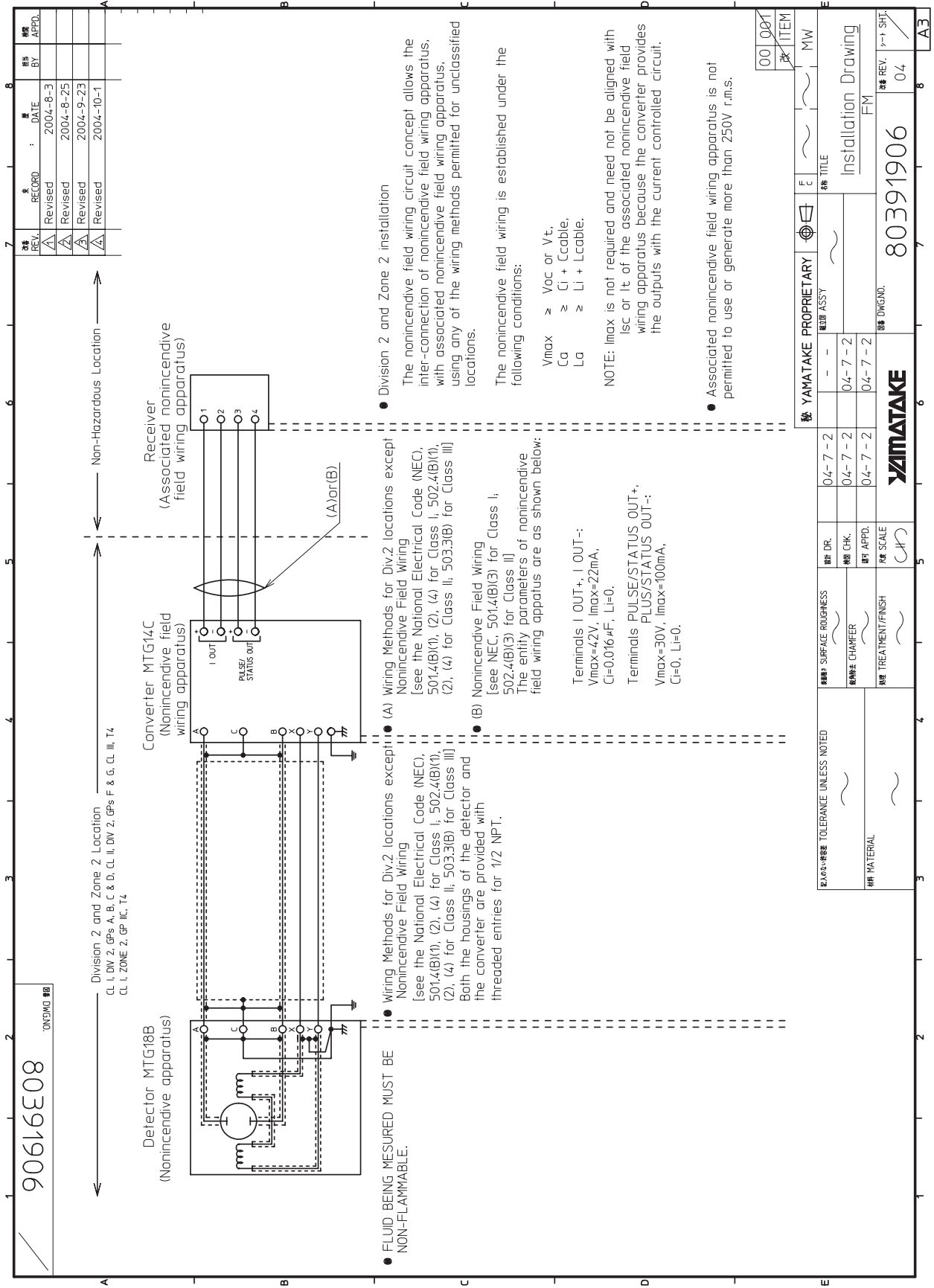

REV.	RECORD	DATE	BY	APPD.
△	Revised	2004-8-3		
△	Revised	2004-8-25		
△	Revised	2004-9-23		
△	Revised	2004-10-1		

秘 YAMATAKE PROPRIETARY	製図 ASSY	04-7-2	04-7-2	04-7-2
00 00T	ITEM	MW		
* TITLE				
Installation Drawing				
FM				
製図 DWGNO. 80391906				
REV. 04				
シフト				
A3				

CSA certification with remote models MTG18B (detector) and MTG14C (converter)

Approval selection code “2”

Protection codes

Model MTG18B:

Class I, Division 2, Groups A, B, C and D; Class II, Division 2, Groups E, F, G; Class III:

- Supply rated 42V, 22mA max. and 30V, 100mA.
- Enclosure rating Type 4X (IP67 rating tested to IEC 60529)
- Temperature Code T4, Ta = -20°C to +60°C

Model MTG14C:

Class I, Division 2, Groups A, B, C and D; Class II, Division 2, Groups E, F, G; Class III:

- Enclosure rating Type 4X (IP67 rating tested to IEC 60529)
- Temperature Code T4, Ta = -20°C to +60°C

Warnings

Model MTG18B:

Explosion Hazard - Do not disconnect equipment unless power has been switched off or the area is known to be non-hazardous.

Model MTG14C:

Explosion Hazard - Substitution of components may impair suitability for Class I, Division 2.

Installation

Installations shall comply with the relevant requirements of the Canadian Electrical Code, Part I.

Process fluid temperature and pressure limit for model MTG18B

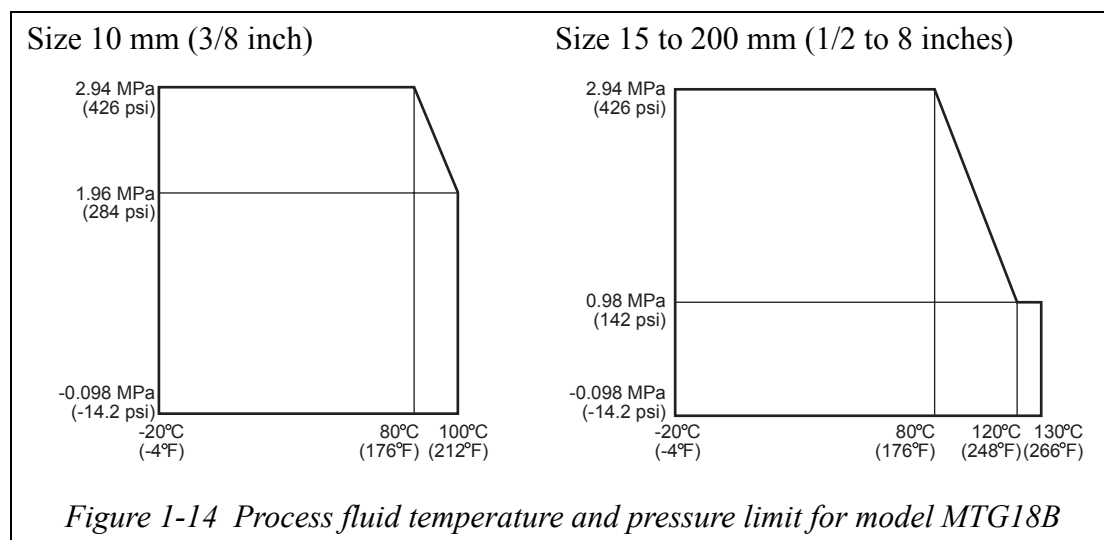

Chapter 2 : Instrument installation

Outline of this chapter

This chapter describes the instrument installation procedures.

The necessary components and installing methods depend on the grounding ring material and installed pipe material.

The description proceeds in the following order:

- Criteria for selecting an installation environment
- Outline of installation method of the instrument
- Material wise detailed installation methods

2-1 : Before installation

Criteria for installation location (1)

Introduction

To bring out the performance of this instrument to the maximum, choose the optimum installation location according to the following criteria for installation location.

Cautions on surrounding environment

- **Install at a place where the ambient temperature is in the range from -4°F to +140°F (-20°C to +60°C) and ambient humidity in the range from 10 to 90% RH. Otherwise, instrument failure or output errors may result.**
- **Avoid a place close to a large-current cable, motor or transformer that may bring about inductive interferences. Otherwise, instrument failure or output errors may result.**
- **Avoid a place where there are severe vibrations or a highly corrosive atmosphere. Otherwise, a broken detector or damaged instrument may result.**
- **Avoid a place exposed to direct sunlight. Otherwise, output errors may result.**

Cautions on measured fluid

As to the measured fluid, the installation location must satisfy the following conditions to avoid output errors and fluctuations.

- **The electrical conductivity of the fluid to be measured must match the stated specifications (specs vary according to converter used) and should be more or less constant.**
- **The fluid to be measured must be electro chemically homogenized. For example, if two fluids are mixed at an upstream a point, the device should be installed at a point so that the two fluid can be evenly mixed by the time they reach the measuring point.**
- **If an ingredient or additive is mixed in, the ingredient distribution must be nearly uniform or homogeneous.**
- **For the following fluids, do not use this instrument even if the electric conductivity, temperature, pressure and others are within the instrument specifications because they can cause problems in measurement.**
 - (1) **Fluids that have sufficient conductivity at high temperatures, but do not satisfy the conductivity requirement at room temperature (about 68°F (20°C)). (For example, fatty acids and soap)**
 - (2) **Certain fluids that contain surfactant (For example, rinse, shampoo and CWM)**
 - (3) **Insulating adhesive materials (For example, oil, kaolinite, kaolin, calcium stearate)**
 - (4) **Slurry fluids containing solid matter (For example, pulp slurry, mud slurry, cement slurry)**

Cautions after installation **CAUTION**

- (1) After installation, do not use this instrument as a foothold or any others improper purpose. Going so may result in damage to the instrument and/or physical injury.
- (2) The integral type of this instrument uses gland for the converter window. Hitting the glass position of the indicator with a tool may break the glass and/or cause physical injury.

 **WARNING**

- (1) Before removing this unit, confirm that there is no residual liquid or pressure inside the piping and the detector to avoid personal injury on damage to the unit.

- The output signal or indication may fluctuate depending on pulsation or other conditions of the fluid. In such cases, increase the damping time constant or take some other measure.

Criteria for installation location (2)

Installed position

Install the instrument at a place where the measured fluid always fills inside the detector. An example of installation is shown in the figure below to illustrate this condition.

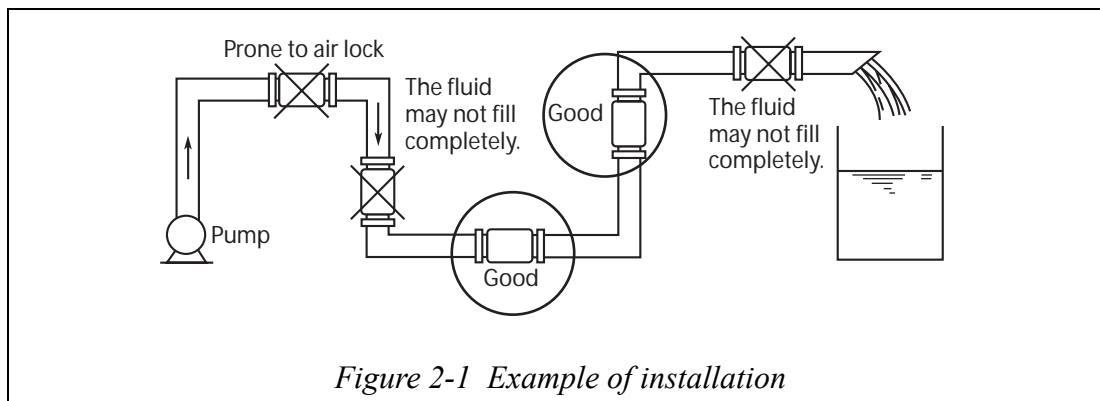

- ~Note**
- *The detector must be positioned as shown by the circled areas in the figure shown above. If the pipe is not filled output errors will occur.*
 - *If the measured fluid is highly viscous, we recommend installing the instrument on a vertical pipe, in order to secure an axial symmetrical flow.*
 - *Install a straight pipe section on the upstream side of the detector. For the straight section length, see the figure below.*

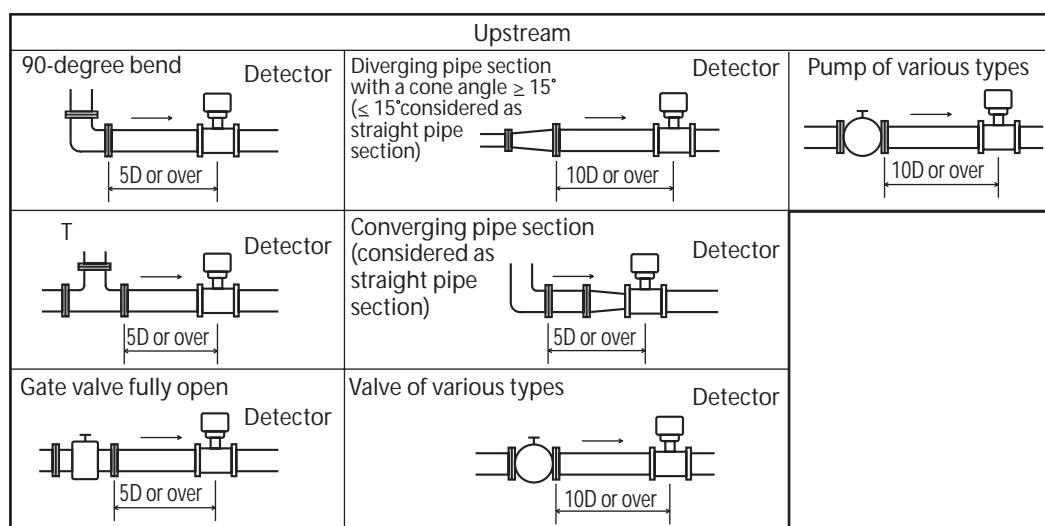

Figure 2-2 Straight pipe section upstream of detector (D: Nominal detector bore diameter)

- No straight pipe section is basically needed on the downstream side. However, ensure 2D or over if influences of drift are foreseen.
- Select an installation location where there is no major flow pulsation or vibration (away from a pump)
- Ensure adequate maintenance space.

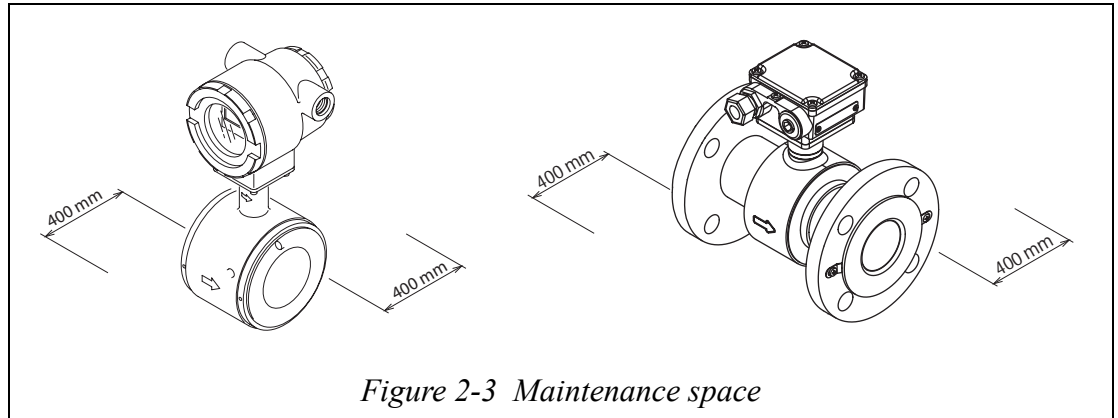

Figure 2-3 Maintenance space

Method of changing the direction of converter

In some location, the direction of the converter may be unsuitable if the detector is installed as it was shipped. In this case, the converter can be repositioned before installation.

The direction of the detector and the converter (integral type) can be changed using the procedure described below.

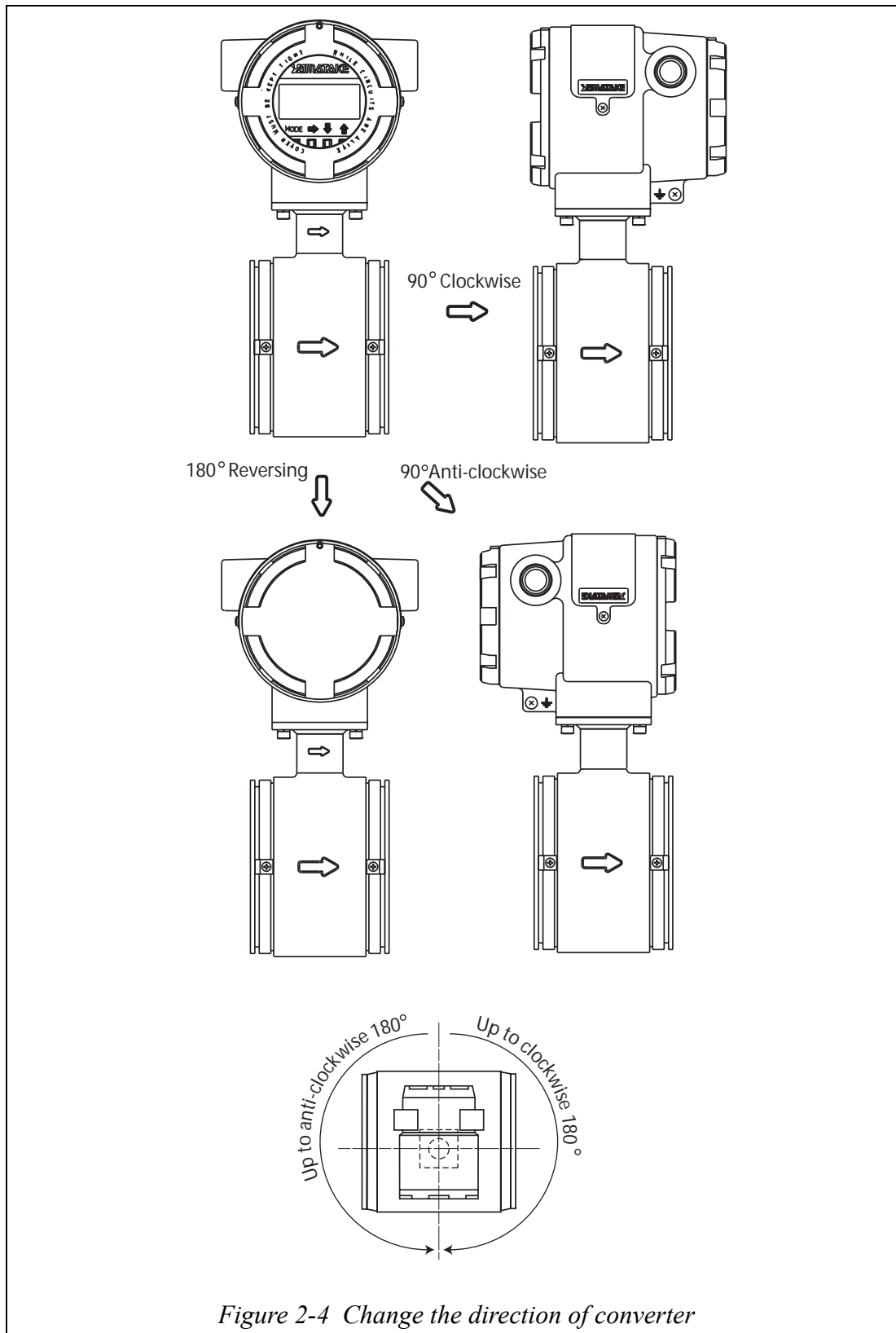

Figure 2-4 Change the direction of converter

Step	Procedure
1	Turn off the power supply (with a breaker etc.) of the converter.
2	Using an M5 wrench remove the four screws securing the converter to the detector. ~Note <i>After removing the screws and when changing the orientation of the detector and the converter. Ensure caution not to apply any force or load to the cable and the connectors. Failure to do so might cause damage to the cable, connector, printed circuit board or cause open circuit and malfunctions.</i>
3	Decides the direction between the detector and the converter. ~Note <i>Do not twist the cable when the connected cable between the detector and the converter rotate. Damage might cause connector and it cause the open circuit etc. of wiring.</i>
4	Tightens the four set screw (The tightening torque: 4.4 N•m \pm 15%). It tighten four screws in the diagonal, and four screws must tighten almost evenly. Moreover, note that there is possibility to bites the dust into the tapped hole after tightening work in the place with dust.

- ~Note**
- *Disconnect all cables before proceeding to change the orientation of the detector and the converter.*
 - *Do not perform the orientation change in locations containing humidity and dust.*
 - *During reassembly check the sealing surface and the condition of the O-ring for any damage.*

Changing the direction of display/data setting device

Changing the display / data setting device direction

The display / data setting device can be repositioned to a horizontal or vertical direction.



Step	Procedure
1	Turn off the power supply (with a breaker etc.) of the converter
2	The converter front cover is fixed by hexagon socket head setscrews (M3). Loosen the setscrews with an Allen wrench (1.5).
3	Remove the converter front cover by turning it counterclockwise with the dedicated tool. ~Note <i>Remove the front cover straight towards you with care.</i>
4	The display / data setting device is fixed by three screws. Remove these screws. ~Note <i>The screws are not captive to the display / data setting device, so take care not to drop them.</i>
5	Remove the display / data setting device. ~Note <i>A cable is attached to the rear side of the display / data setting device. This cable is connected to the connector on the converter proper.</i>
6	Turn the display / data setting device to the desired direction and align it to the threaded holes in the converter proper. ~Note <i>Sets the direction of the display/data setting unit in a movable range in Figure 2-6.</i>
7	Fix the display / data setting device again using the three screws. When tightening the screws, take care not to entangle the cable.
8	Attach the front cover. ~Note <i>Take care not to injure your fingers by the cover edge or the thread in the case.</i>

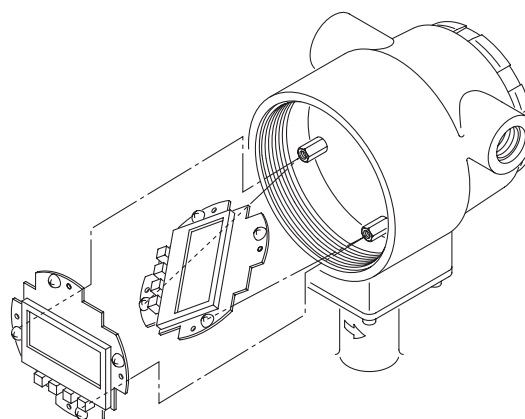
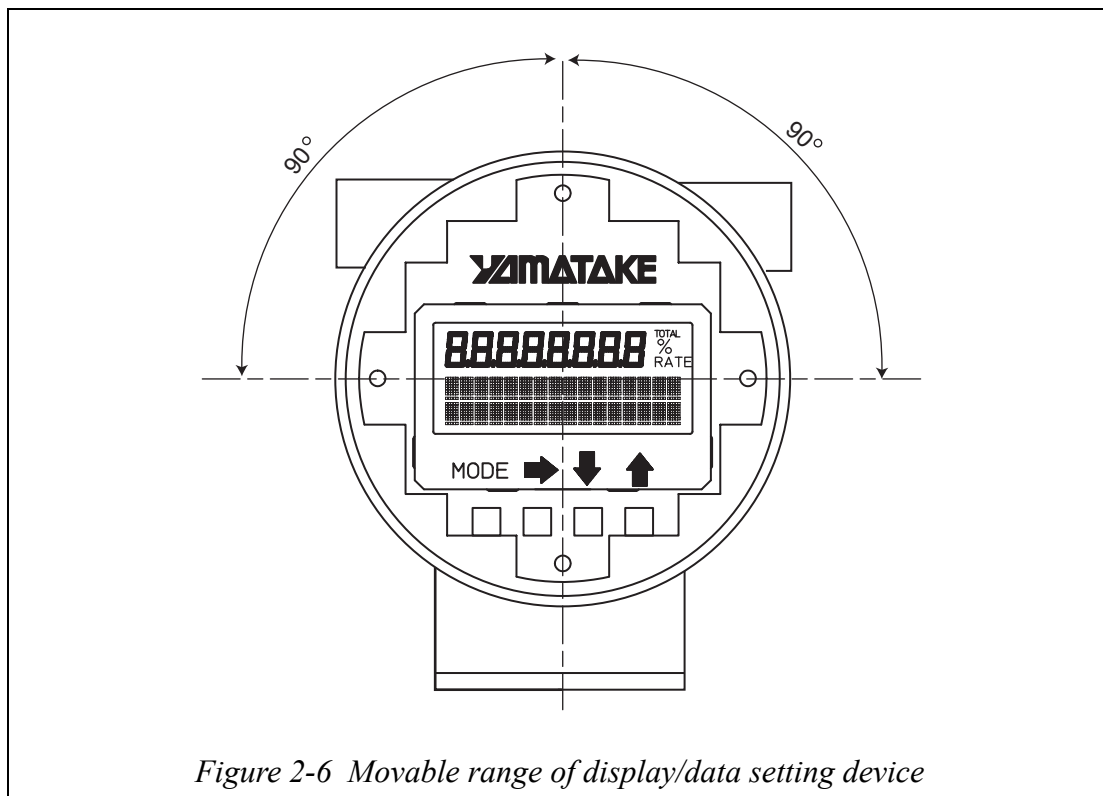

Figure 2-5 Changing the display / data setting device direction

Movable range of display/data setting device



~Note *Do not unpack the flowmeter in a location containing high humidity, corrosive gas atmosphere and dusty. There is an effect of preventing injury by static electricity when working to be near to prevent and internal element being damaged by static electricity when touches an internal display board after it lightly touches the metal structure (However, it should be grounded).*

Wiring connection distance of remote-type converter and detector

When installing the converter and the detector, there is limitation on the cable length by the conductivity of the fluid to be measured and the diameter of the detector. Select the wiring distance (cable length) after confirming the following specification. Use our special cable (model SMC11) for the wiring between the converter and the detector.

For the diameter 10 mm or 15 mm

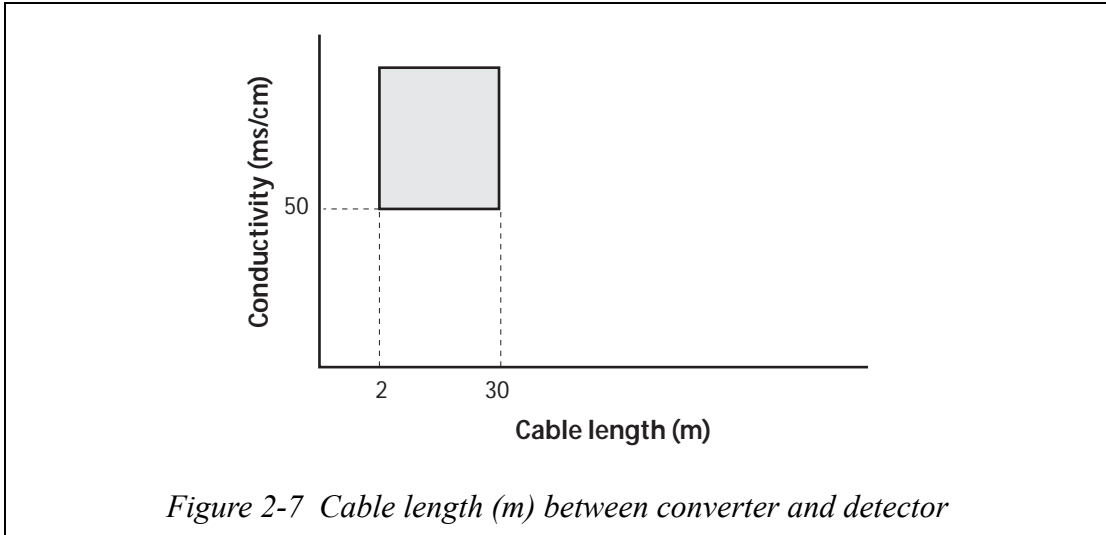

For the diameter 25 mm or more

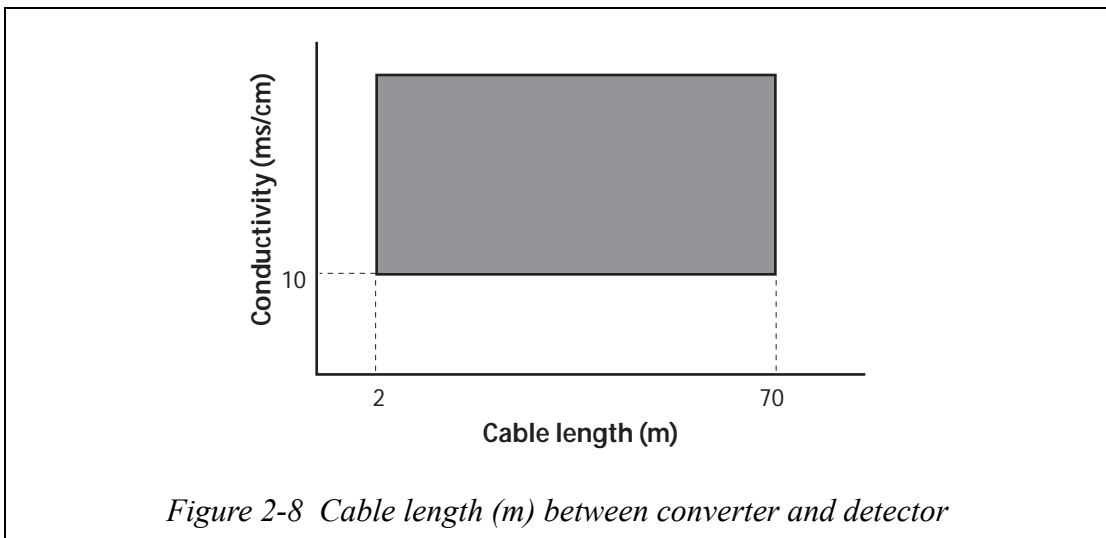

2-2 : Installation method

2-2-1 : Installing a wafer type detector

Basic installation

Introduction

Process connection of the instrument are wafer type, flange type, union, hose, or clamp unit. Referring to the appropriate method of installation, install the unit properly.

Installation example

Figure 2-9 shows the basic method for installing the device.

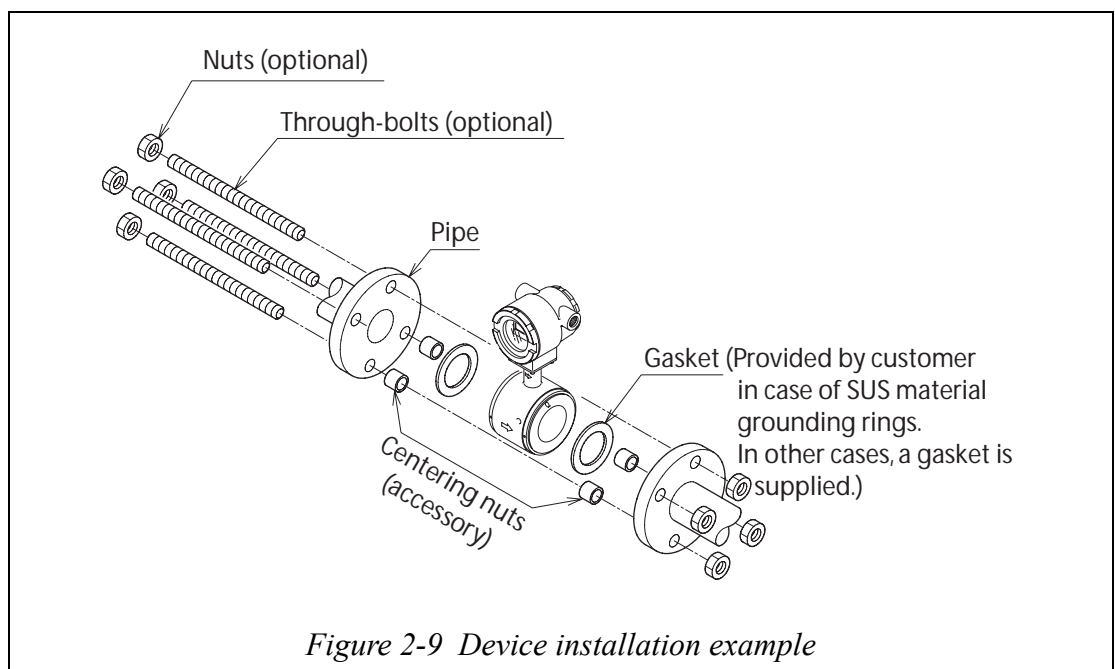

⚠ CAUTION

Be careful in handling this unit. It is heavy, dropping it accidentally could cause injury.

Fastening torque

⚠ CAUTION

Table 2-1 shows the fastening torque for each pipe bore. Using centering hardware, apply the prescribed fastening torque to prevent any liquid leak from the pipe.

Table 2-1 Fastening torque

Nominal detector bore	Fastening torque
25 mm	20 to 30 N•m (14.7 to 22.1 ft•lb)
40 mm, 50 mm, 65 mm, 80 mm	30 to 50 N•m (22.1 to 36.8 ft•lb)
100 mm	50 to 70 N•m (36.8 to 51.6 ft•lb)

Flange shape

The flanges used should be such that the area of contact with the gasket is maximized, as shown in Figure 2-10.

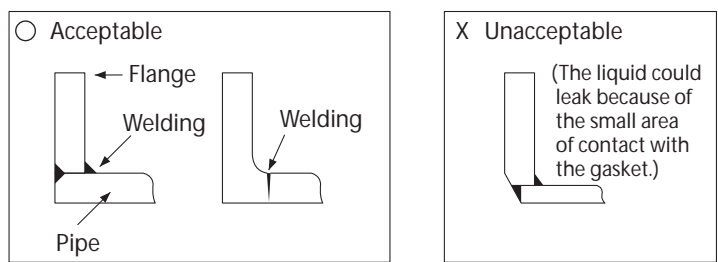
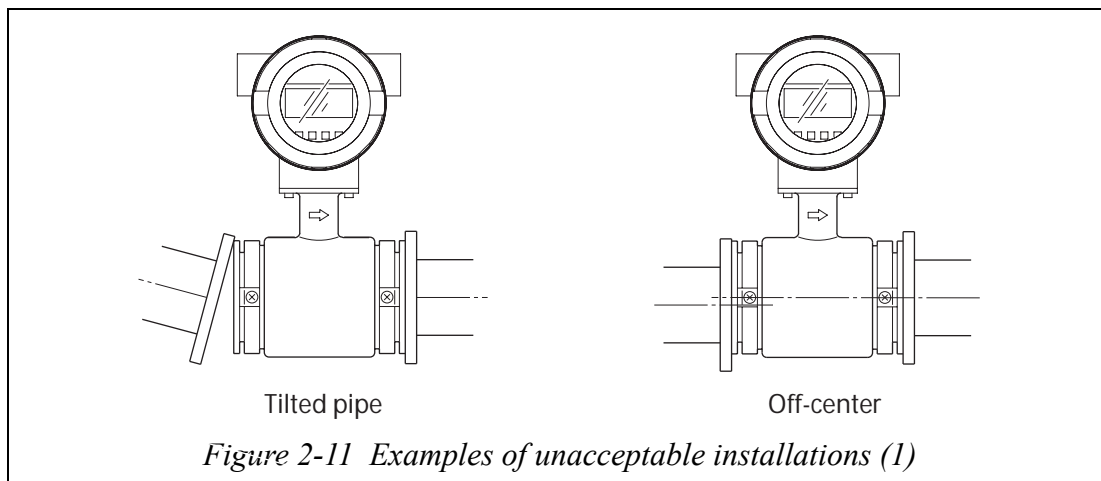

Figure 2-10 Flange shape

- ~Note**
- ***Before installing the detector be sure to flush out any foreign matter that may be present inside the detector. Residual foreign matter could cause output fluctuations.***
 - ***Do not touch the electrodes by your hand or waste cloth with oil. It could cause output fluctuations.***
 - ***Install the detector in accordance with the flow direction mark on the detector with the direction of the liquid flow. Misalignment could result in a negative output.***

CAUTION

Before installing the detector make sure that the pipe is exactly straight and centered. Any irregularity in these respects could cause leakage or other hazards.



~Note *Never attempt to force the detector between two piping flanges when the space is too narrow. It can damage the detector.*

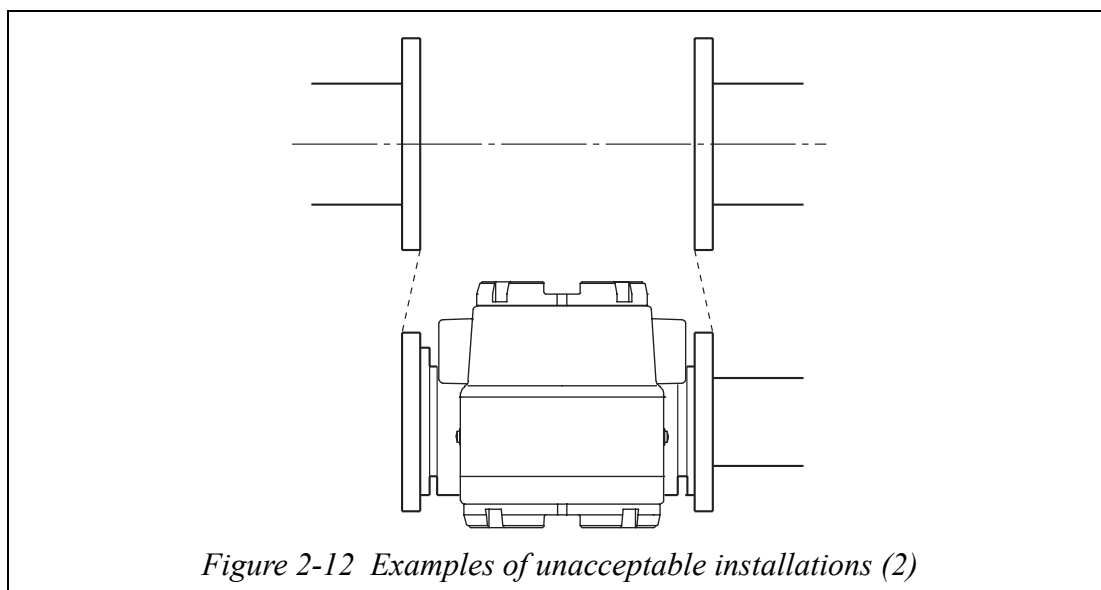

WARNING

Ensure the bore diameters of the pipe and the detector are exactly the same, install the detector so that the gasket does not protrude into the internal bore of the pipe, as this could result in leakage or other hazards.

~Note *Tighten each bolt a little at a time and apply uniform torque to all the bolts. If leakage does not stop on completion of fastening, make sure that the pipe is not off center, then tighten each bolt little by little. Install the detector carefully and ensure continue to that the fastening torque does not exceed the prescribed limit, otherwise the detector could be damaged.*

Accessory parts for installation

Introduction

The following parts are necessary for the installation of the detector:

- Centering nuts (standard accessory: 4 pcs.)
- Through bolts and nuts (option)
- Gaskets: Gaskets are to be provided by the customer when using grounding rings made of SUS material.
Gasket are supplied as a standard accessory, when using grounding rings made of hastelloy, titanium, tantallum, or platinum.
- Protective plate: Required when connecting the detector to polyvinyl chloride (PVC) piping

Centering nuts

To install the detector, use centering nuts to ensure the exact center line alignment of the pipe and the detector.

Slip the centering nuts onto the through-bolts, and set the detector on top of the nuts so that the nuts are on four sides of the detector.

The positions of the centering nuts depend on the direction in which the detector is installed.

For the positions of the centering nuts, refer to Figure 2-13 and Figure 2-14.

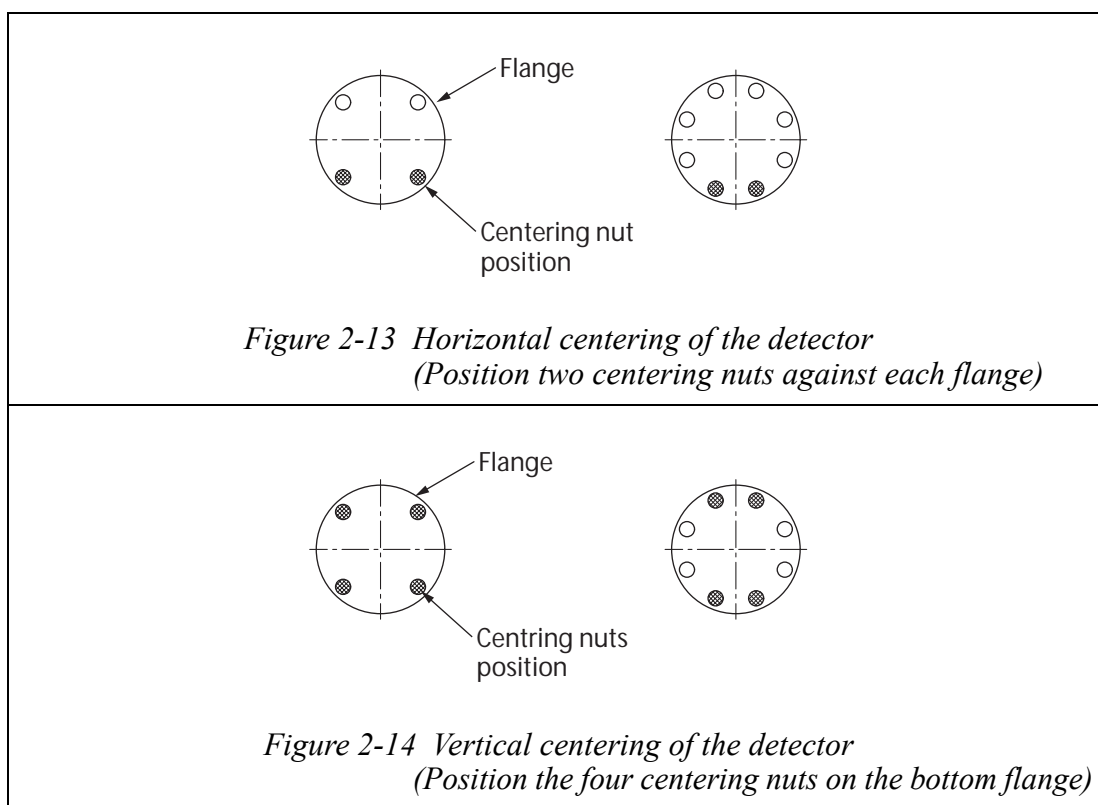

Gaskets

Gaskets are supplied with the grounding ring as standard accessory, except when it is made of SUS material. Secure gaskets when you use a grounding ring made of SUS material. We recommend gasket material such as joint sheet or PTFE. For the internal diameters of the gaskets, refer to Table 2-2. We do not recommend the use of rubber gaskets. Observe the precautions below.

- ~Note
- *A gasket with too small internal diameter may generate turbulent flow, resulting in inaccurate measurements.*
 - *A gasket with too large internal diameter may cause leakage. Also, any solid substance in the fluid to be measured could accumulate between the gasket and the flange, resulting in inaccurate measurements.*

Table 2-2 Recommended internal diameters of gaskets

(Unit: mm)

Nominal detector bore diameter Dimensions	25 mm (1 inch)	40 mm (1½ inch)	50 mm (2 inches)	65 mm (2½ inches)	80 mm (3 inches)	100 mm (4 inches)
	Gasket internal diameter	25.5 ±1	40.5 ±1	52 ±1	65 ±1	79 ±1

If you install the detector at a lower torque level using rubber gaskets, you must use gaskets with the internal and external diameters shown in Table 2-3 and Table 2-4 for the respective pipe size. Depending on the grounding ring material, two gaskets of different thicknesses may be required. (See Figure 2-20 on page 2-22 and Figure 2-23 on page 2-24.)

Table 2-3 Internal and external diameters of rubber gaskets (0.5 to 1 mm thick)

(Unit: mm)

Nominal detector bore diameter Dimensions	25 mm (1 inch)	40 mm (1½ inch)	50 mm (2 inches)	65 mm (2½ inches)	80 mm (3 inches)	100 mm (4 inches)
	Gasket internal diameter	25.5 ±1	40.5 ±1	52 ±1	65 ±1	79 ±1
Gasket external diameter	50 ±1	75 ±1	91 ±1	111 ±1	121 ±1	146 ±1

Table 2-4 Internal and external diameter of rubber gaskets (3 to 4 mm thick)

(Unit: mm)

Nominal detector bore diameter Dimensions	25 mm (1 inch)	40 mm (1½ inch)	50 mm (2 inches)	65 mm (2½ inches)	80 mm (3 inches)	100 mm (4 inches)
	Gasket internal diameter	25.5 ±1	40.5 ±1	52 ±1	65 ±1	79 ±1
Gasket external diameter	50 ±1	68 ±1	84 ±1	104 ±1	114 ±1	139 ±1

Selecting an installation method

CAUTION

The necessary materials and the installation method vary according to the material of the ring and that of the pipe on which the detector is to be installed. Select the appropriate method of installation after confirming the specifications of the detector to be installed and the conditions of installation. Improper installation may result in leakage or damage to the pipe flanges.

Installation method according to materials

Select the appropriate installation method from the table below.

Pipe material	Grounding ring material	See page
Metal	SUS material	page 2-19
	Non-SUS material	page 2-20
PVC	SUS material	page 2-21
	Non-SUS material	page 2-23

Installation on horizontal pipe

⚠ CAUTION

Improper installation may result in leakage or cause damage to the pipe flanges.

Required accessories

The following parts are required:

- Through-bolts and nuts
- Centering nuts
- Gaskets: The required gasket material will vary according to the material of the pipe on which the detector is to be installed. See the installation procedures for different pipe materials described on page 2-19 to page 2-24.

Procedure

Follow this procedure to install the detector on a horizontal pipe.

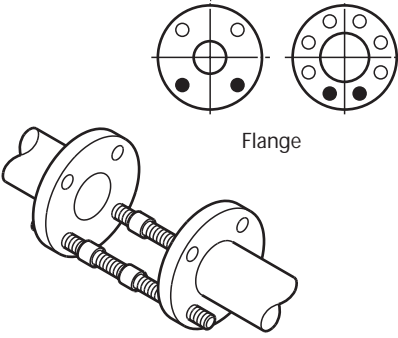
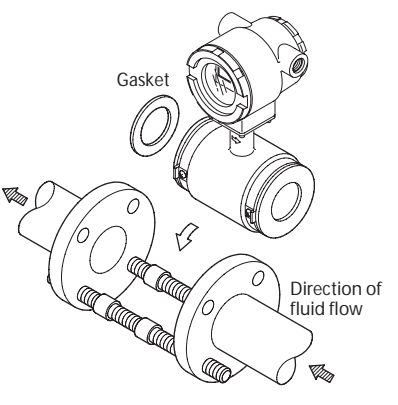
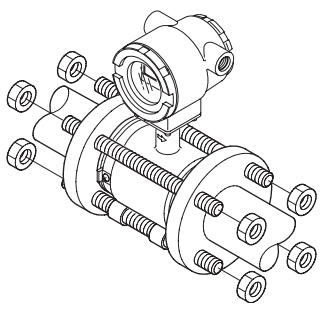
Step	Action	Drawing
1	<ul style="list-style-type: none"> • Insert through-bolts in the flange holes shown by black dots in the drawing. Slip two centering nuts onto each through-bolt before inserting the bolts. 	
2	<ul style="list-style-type: none"> • Turn the detector so that the direction mark on the detector matches the direction of fluid flow. • Insert the detector and gaskets between the pipe flanges. • Position the detector so that it sits on top of the centering. 	
3	<ul style="list-style-type: none"> • Make sure that the detector remains properly centered. • Make sure that the gaskets do not protrude beyond the edges of the pipe flanges. • When you have checked these items, insert the remaining through-bolts into the flange holes and tighten the bolts evenly using the appropriate fastening torque given on page 2-12. 	

Installation on vertical pipe

⚠ CAUTION

Improper installation may result in leakage or damage to the pipe flanges.

Required accessories

The following parts are required:

- Through-bolts and nuts
- Centering nuts
- Gaskets: The required gasket material will vary according to the material of the pipe on which the detector is to be installed. See the installation procedures for different pipe materials described on page 2-19 to page 2-24.

Procedure

Follow this procedure to install the detector on a vertical pipe.

Step	Action	Drawing
1	<ul style="list-style-type: none"> • Of the flange holes shown by black dots in the drawing, insert through-bolts into the two holes at the back and fasten them lightly with nuts. Slip one centering nut onto each through bolt before inserting the bolts. 	
2	<ul style="list-style-type: none"> • Turn the detector so that the direction mark on the detector matches the direction of fluid flow. • Insert the detector and gaskets between the pipe flanges. 	
3	<ul style="list-style-type: none"> • Insert through-bolts fitted with one centering nut each into the remaining two flange holes shown by black dots in steps 1 and 2. 	
4	<ul style="list-style-type: none"> • Make sure that the detector remains properly centered. • Make sure that the gaskets do not protrude beyond the edges of the pipe flanges. • When you have checked these items, insert the remaining through-bolts into the flange holes and tighten the bolts evenly using the appropriate fastening torque given on page 2-12. 	

Installation on metal pipe (1)

Introduction

The installation method described in this section corresponds to the following combination of pipe and grounding ring materials. For the installation method corresponding to any other combination, refer to the table on page 2-16.

Pipe material: Metal

Grounding ring material: SUS

Required accessories

The following parts are required:

- Through-bolts and nuts
- Centering nuts
- Gaskets: We recommend using non-rubber gaskets such as those made of joint sheet or PTFE.

For recommended internal diameters, refer to Table 2-2 on page 2-15. Although rubber gaskets may be used, it is not possible to reduce the fastening torque.

Installation procedure

- Install the detector as shown in Figure 2-15. The torque level for tightening the bolts is not related to the gasket material. See Table 2-1 on page 2-12 for the appropriate torque. For the internal diameter of the gaskets, see Table 2-2 on page 2-15.
- To use rubber gaskets for a low fastening torque, refer to page 2-24.

CAUTION

Please note that the use of rubber gaskets and a lower fastening torque may result in insufficient surface pressure between the lining and the grounding ring, resulting in leakage.

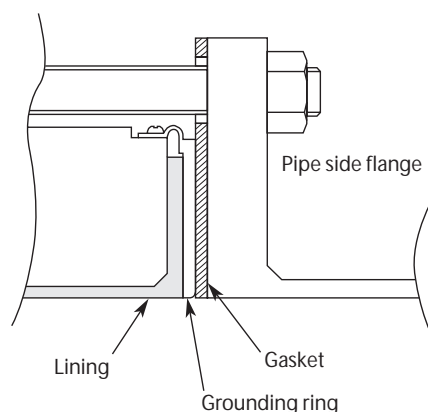

Figure 2-15 Installation using SUS material grounding ring and metal pipe

Installation on metal pipe (2)

Introduction

The installation method described in this section corresponds to the following combination of pipe and grounding ring materials. For the installation method corresponding to any other combination, refer to the table on page 2-16.

Pipe material: metal

Grounding ring material: Non-SUS

Required accessories

The following parts are required. No gaskets are necessary since PTFE gaskets are provided.

- Through-bolts and nuts
- Centering nuts

Installation procedure

- Install the detector as shown following figures. See Table 2-1 on page 2-12 for the appropriate fastening torque.
- To use rubber gaskets for a low fastening torque, refer to page 2-24.

⚠ CAUTION

Please note that the use of an additional gasket besides the existing PTFE gasket may result in leakage (see Figure 2-17)

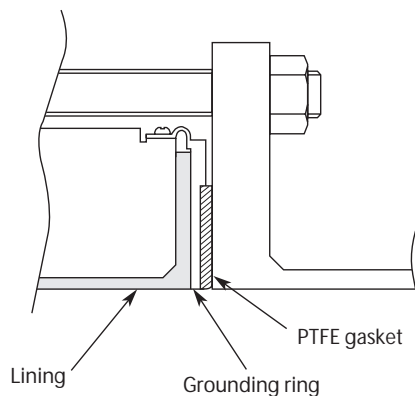

Figure 2-16 Installation using Non-SUS material grounding ring and metal pipe

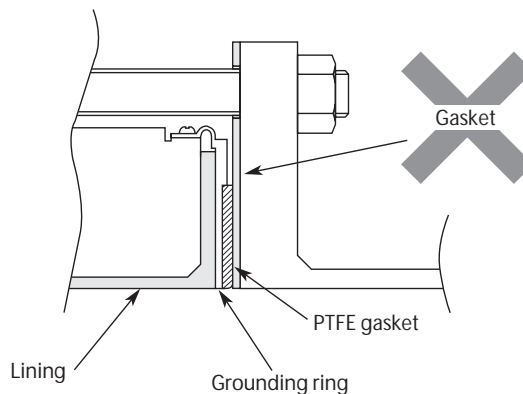

Figure 2-17 Example of incorrect installation

Installation on PVC pipe (1)

Introduction

The installation method described in this section corresponds to the following combination of pipe and grounding ring materials. For the installation method corresponding to any other combination, refer to the table on page 2-16.

Pipe material: PVC

Grounding ring material: SUS

Required accessories

The following parts are required:

- Through-bolts and nuts
- Centering
- Gaskets: Non-rubber gaskets are recommended (i.e. joint sheet or PTFE). See Table 2-2 on page 2-15 for the recommended bore diameters. When using rubber gaskets, another gasket of the same material and with a thickness of 0.5 to 1.0 mm is required. See Table 2-3 on page 2-15 for the appropriated dimensions.
- Protective plate: Use the protective plate if bolt tightening at the specified torque threatens to warp or damage the PVC pipe. See Figure 2-19 for an illustration of the protective plate.

Installation procedure

The installation procedure varies with such conditions as the fastening torque and the need for a protective plate. Choose one of the following three methods as applicable.

1. Use this method to install the detector with a specified fastening torque.
Install the detector as shown in Figure 2-18.
The torque level for tightening the bolts is not related to the gasket material. See Table 2-1 on page 2-12 for the appropriate torque. For the internal diameter of the gaskets, see Table 2-2 on page 2-15.

CAUTION

Please note that the use of rubber gaskets and a lower fastening torque may result in insufficient surface pressure between the lining and the grounding ring, resulting in leakage.

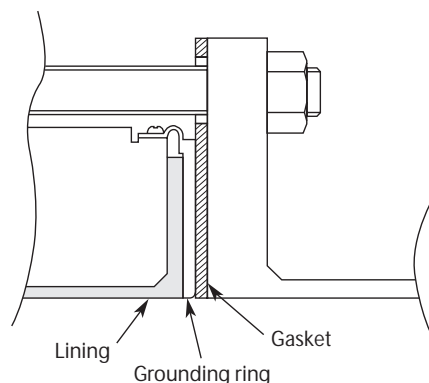

Figure 2-18 Installation using SUS material grounding ring

- Use this method to install the detector using a protective plate to prevent the PVC pipe from being deformed or damaged when the bolts are tightened with the specified torque.

Install the protective plate between the outer side of the PVC flange and the detector, as shown in Figure 2-19. The protective plate protects the PVC pipe from deformation or damage when secured at the specified torque. The torque level is unrelated to the pipe or grounding ring material. See Table 2-1 on page 2-12 for the appropriate torque.

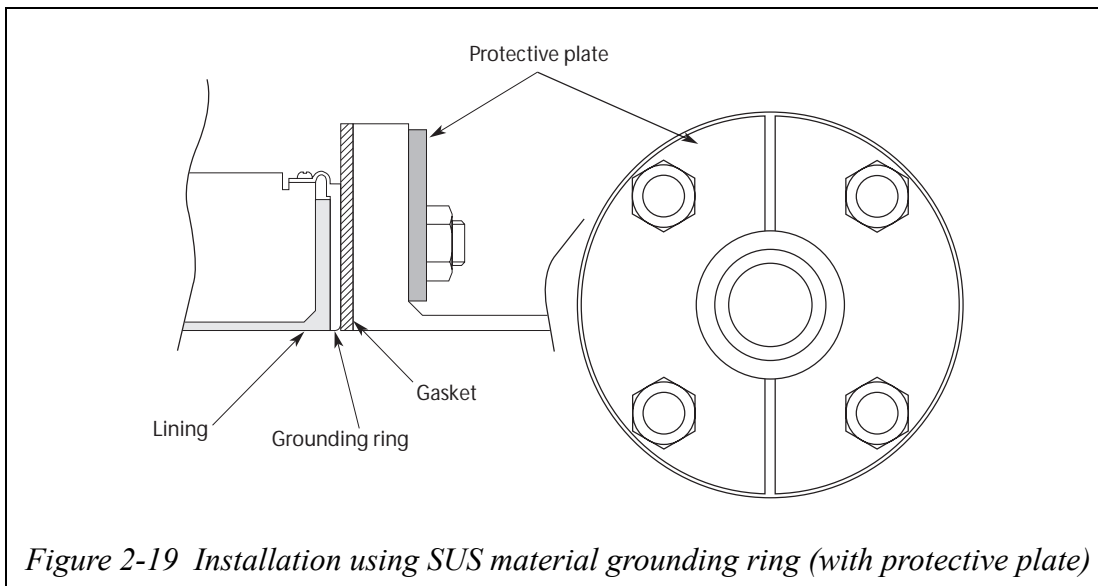

Figure 2-19 Installation using SUS material grounding ring (with protective plate)

- Use this method to install the detector using a low fastening torque and rubber gaskets.

Remove the grounding ring from the detector, insert a rubber gasket 0.5 to 1.0 mm thick, then reinsert the grounding ring on top of the rubber gasket. With the rubber gasket in the position shown in Figure 2-20, attach the detector to the pipe. Fasten the bolts with a torque that provides a leakproof joint. In this case, use the two kinds of rubber gaskets made of the same material.

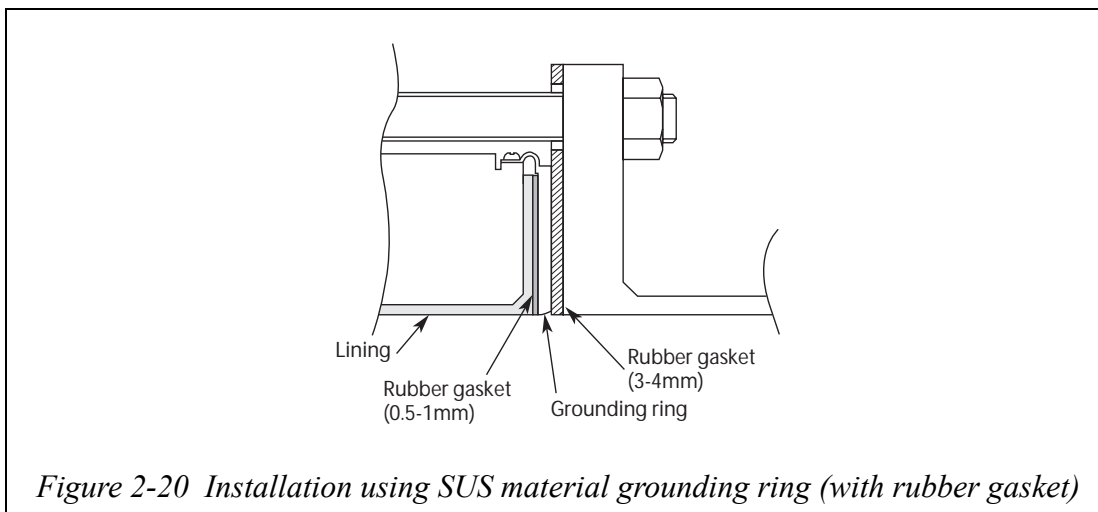

Figure 2-20 Installation using SUS material grounding ring (with rubber gasket)

Installation on PVC pipe (2)

Introduction

The installation method described in this section corresponds to the following combination of pipe and grounding ring materials. For the installation method corresponding to any other combination, refer to the table on page 2-16.

Pipe material: PVC

Grounding ring material: Non-SUS material

Required accessories

The following parts are required:

- Through-bolts and nuts
- Centering nuts
- Gaskets: No gaskets are necessary due to the provision of a PTFE gasket. When using a rubber gasket, two gaskets of the same material and of two thicknesses, 0.5 to 1.0 mm and 3.0 to 4.0 mm, are required. See Table 2-3 and 2-4 on page 2-15 for the appropriate dimensions.
- Protective plate: A protective plate is required if tightening the bolts to the specified torque may deform or damage the PVC pipe. Use stainless steel or similar hard metal 1 mm thick or more. For the shape, see Figure 2-19.

Installation procedure

The installation procedure varies with such conditions as the fastening torque and the need for a protective plate. Choose one of the following three methods as applicable.

1. Use this method to install the detector with the specified fastening torque. Install the detector as shown in Figure 2-21. See Table 2-1 on page 2-12 for the appropriate fastening torque.

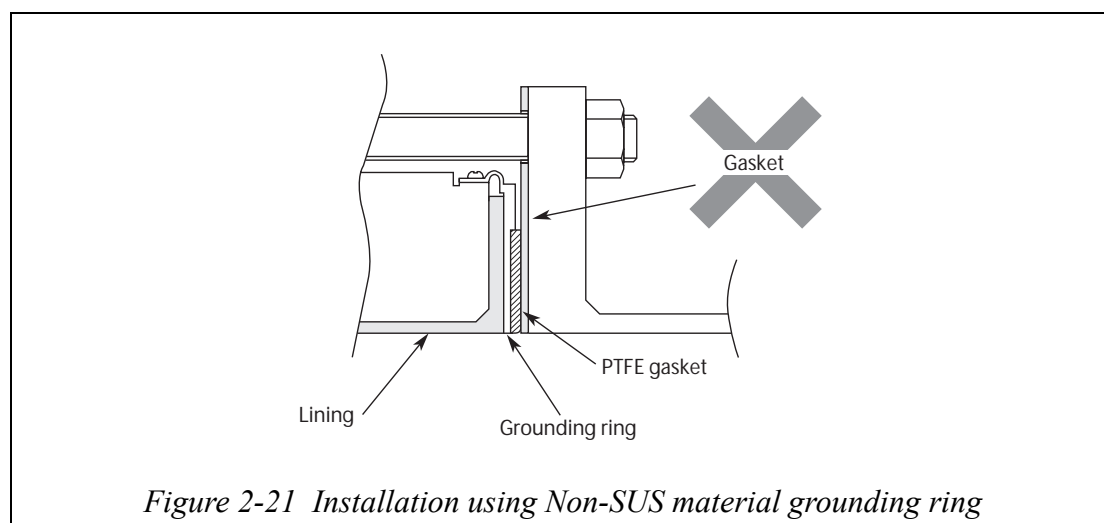
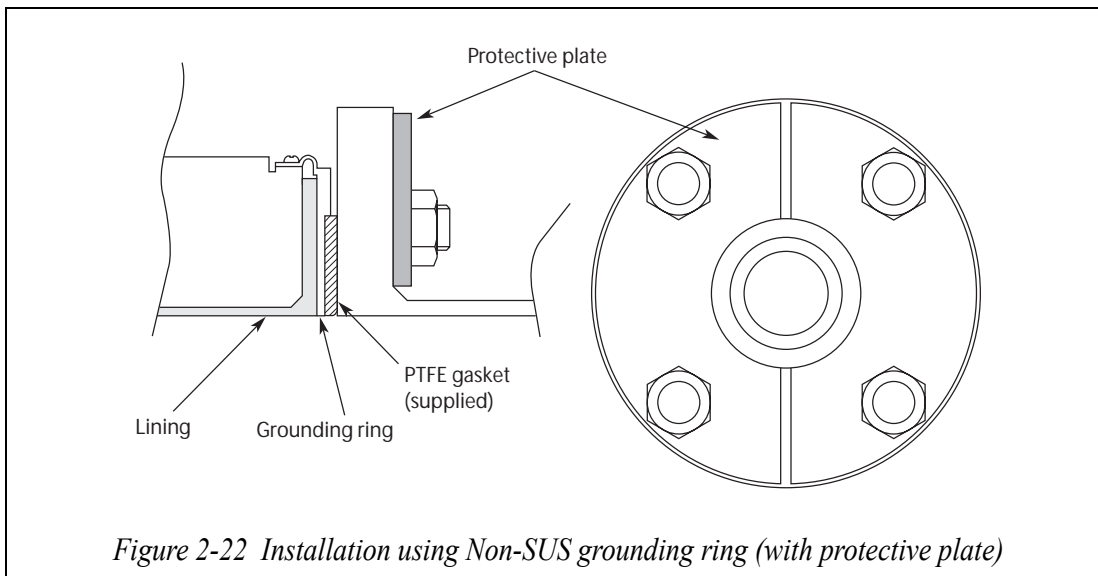
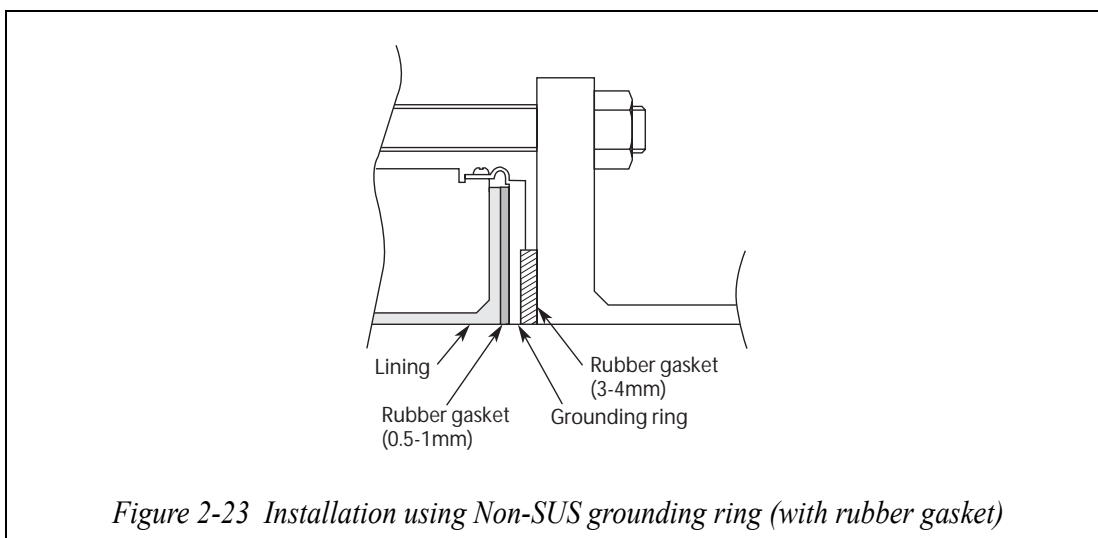

Figure 2-21 Installation using Non-SUS material grounding ring

2. Use this method to install the detector along with a protective plate to prevent PVC pipe from being deformed or damaged when the bolts are tightened to the specified torque.
 Insert a protective plate between the outer side of the PVC flange and the detector as shown in Figure 2-22. The protective plate protects the PVC pipe from deformation or damage when it is secured to the specified torque. For the appropriate torque, see Table 2-1 on page 2-12.



3. Use this method to install the detector using a low fastening torque and rubber gaskets.
 First, remove the grounding ring from the detector, then insert a rubber gasket with a thickness of 0.5 to 1.0 mm. Then reinsert the grounding ring on top of the rubber gasket.
 Next, remove the PTFE gasket and insert a rubber gasket 3.0 to 4.0 mm thick to replace it. Under these conditions, install the detector on the pipe as shown in Figure 2-23. Tighten the bolts to the torque required to achieve a fluid seal for the rubber gasket. In this case, the two kinds of rubber gaskets that are used should be made of the same material. For the dimensions of the rubber gaskets, refer to Table 2-3 and Table 2-4 on page 2-15.



2-2-2 : Installation a flange type detector

Basic installation method

Installation example

Figure 2-20 shows the basic method for installing the device.

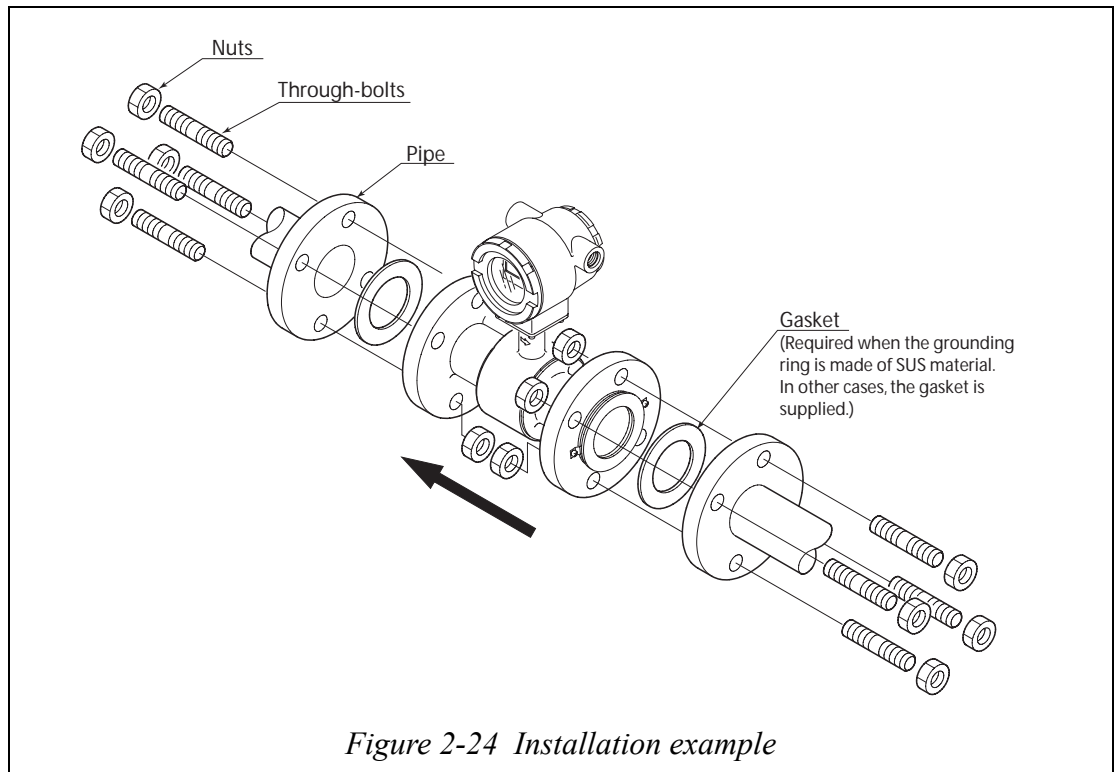

Fastening torque

⚠ CAUTION

Be careful in handling this unit. It is heavy, dropping it accidentally could cause injury.

⚠ WARNING

Table 2-5 shows the fastening torque for each pipe bore. Apply the prescribed fastening torque to prevent leakage.

Table 2-5 Fastening torque

Diameter and flange ratings		Fastening torque N•m (kgf•cm)*	
2.5 to 15 mm	JIS 10K	8 to 13	(82 to 132)*
	JIS 20K	8 to 13	(82 to 132)*
	ANSI/JPI 150	9 to 14	(92 to 143)*
	ANSI/JPI 300	10 to 16	(102 to 163)*
25 mm (1 inch)	JIS 10K	21 to 31	(214 to 316)*
	JIS 20K	21 to 32	(214 to 326)*
	ANSI/JPI 150	11 to 17	(112 to 173)*
	ANSI/JPI 300	22 to 34	(224 to 347)*
40 mm (1½ inch)	JIS 10K	22 to 32	(224 to 326)*
	JIS 20K	22 to 34	(224 to 347)*
	ANSI/JPI 150	13 to 18	(132 to 184)*
	ANSI/JPI 300	36 to 57	(367 to 581)*
50 mm (2 inches)	JIS 10K	24 to 34	(245 to 347)*
	JIS 20K	19 to 31	(194 to 316)*
	ANSI/JPI 150	23 to 32	(235 to 326)*
	ANSI/JPI 300	20 to 32	(204 to 326)*
65 mm (2½ inches)	JIS 10K	20 to 31	(204 to 316)*
	JIS 20K	37 to 61	(377 to 622)*
	ANSI/JPI 150	26 to 35	(265 to 357)*
	ANSI/JPI 300	37 to 57	(377 to 581)*
80 mm (3 inches)	JIS 10K	20 to 31	(204 to 316)*
	JIS 20K	37 to 61	(377 to 622)*
	ANSI/JPI 150	26 to 35	(265 to 357)*
	ANSI/JPI 300	37 to 57	(377 to 581)*
100 mm (4 inches)	JIS 10K	22 to 33	(224 to 337)*
	JIS 20K	41 to 66	(418 to 673)*
	ANSI/JPI 150	21 to 31	(214 to 316)*
	ANSI/JPI 300	43 to 66	(439 to 673)*
150 mm (6 inches)	JIS 10K	47 to 67	(479 to 683)*
	JIS 20K	58 to 91	(592 to 928)*
	ANSI/JPI 150	42 to 60	(428 to 612)*
	ANSI/JPI 300	50 to 74	(510 to 755)*
200 mm (8 inches)	JIS 10K	44 to 65	(449 to 663)*
	JIS 20K	66 to 102	(673 to 1040)*
	ANSI/JPI 150	42 to 59	(428 to 602)*
	ANSI/JPI 300	81 to 120	(826 to 1224)*

~Note *: The numerical value in parentheses is a reference value.

Flange shape

Use flanges that will maximize the area of contact with the gasket, as shown in Figure 2-25.

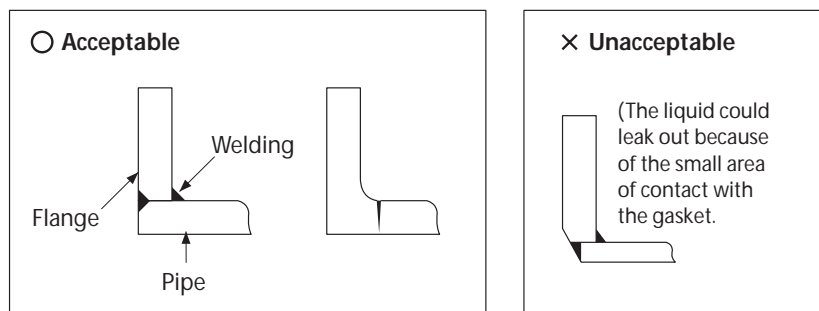

Figure 2-25 Flange shape

~Note

- *Before installing the detector, make sure any foreign matter is flushed from the inside of the detector. Residual foreign matter could cause output fluctuations.*
- *Do not touch the electrodes by your hand or wasted cloth with oil. This could cause output fluctuations.*
- *Install the detector in accordance with the flow direction mark on the detector in the direction of the liquid flow. Misalignment could result in a negative output.*
- *Never attempt to force the detector between two flanges when the space is too narrow. It can damage the detector*

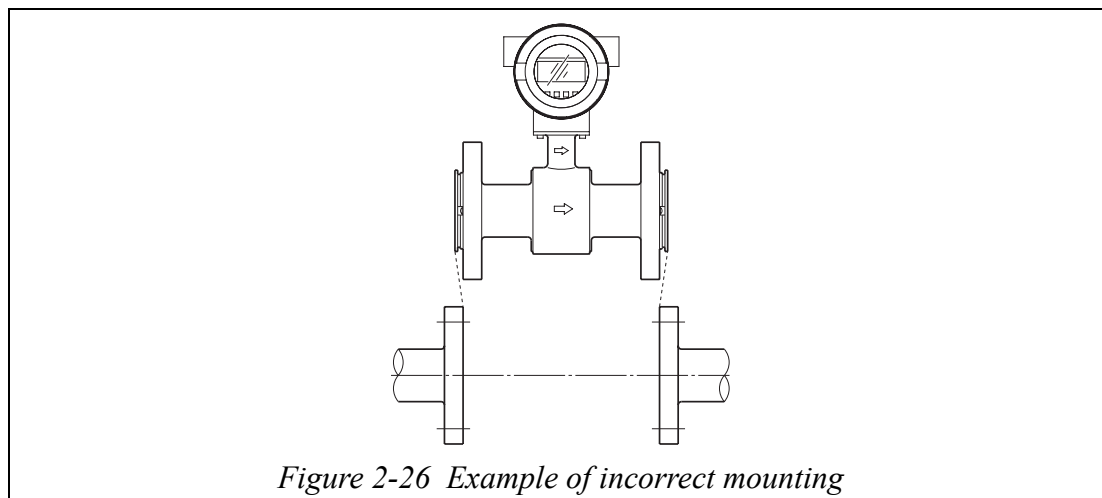

Figure 2-26 Example of incorrect mounting

WARNING

After ensuring that the internal diameter of the pipe and that of the detector are the exactly the same, install the detector so that the gasket does not protrude into the internal diameter of the pipe. Failing to do so could result in leakage or other hazards.

- ~Note *Tighten each bolt a little at a time, apply uniform torque to all the bolts. If leakage does not stop on completion of fastening, make sure that the pipe is not off center, then continue to tighten each bolts little by little. Install the detector carefully and ensure that the fastening torque does not exceed the prescribed limit. Otherwise, the detector could be damaged.*

Accessory parts for installation

Introduction

The following parts are necessary for the installation of the detector:

- Gaskets: Gaskets are to be provided by the customer when using grounding rings made of SUS material.

Gaskets are supplied as standard accessory, when using grounding rings made of other material.

Gaskets

Gaskets are supplied with the grounding ring, except when it is made of SUS material. Gasket are to be provided by the customer when using a grounding ring made of SUS material. We recommend a non-rubber gasket material such as joint sheet or PTFE.

For the internal diameters of the gaskets, refer to Table 2-6.

- ~Note**
- *A gasket with small internal diameter may generate turbulent flow and affect, resulting in inaccurate measurements.*
 - *A gasket with too large internal diameter may cause leakage. Also, any solid substance in the fluid to be measured could accumulate between the gasket and the flange, resulting in inaccurate measurements.*

Table 2-6 Recommended internal diameters of gaskets

Body diameter	Internal diameter (mm)
2.5 mm	11±1
5 mm	11±1
10 mm	11±1
15 mm (½ inch)	16±1
25 mm (1 inch)	25±1
40 mm (1½ inch)	40±1
50 mm (2 inches)	51±1
65 mm (2½ inches)	64±1
80 mm (3 inches)	76±1
100 mm (4 inches)	95±1
150 mm (6 inches)	148±1
200 mm (8 inches)	196±1

Selecting an installation method

Caution



The necessary materials and the method of installation vary depending on the material of the grounding ring and the material. Select the applicable method of installation after checking the specifications of the detector to be installed and the conditions of installation. Improper installation may result in leakage or damage to the pipe flanges.

Installation method according to material

Select the appropriate installation method from the table below.

Pipe material	Grounding ring material	See page
Metal	SUS material	page 2-30
	Non-SUS material	page 2-31
PVC	SUS material	page 2-32
	Non-SUS material	page 2-34

Installation on metal pipe (1)

Introduction

The installation method described in this section is to be used with the following grounding ring materials. For the installation method used for any other grounding ring material, refer to the table on page 2-29.

Pipe material: Metal

Grounding ring material: SUS material

Required accessories

The following parts are required:

- Bolts and nuts
- Gaskets: We recommend using non-rubber gaskets such as those made of joint sheet or PTFE. For recommended internal diameters, refer to Table 2-6 on page 2-28.

Installation procedure

- Install the detector as shown in Figure 2-27. The torque level for tightening the bolts is not related to the gasket material. See Table 2-5 on page 2-26 for the appropriate torque. For the internal diameter of the gaskets, see Table 2-2 on page 2-15.

⚠ CAUTION

A lower fastening torque may result in insufficient surface pressure between the lining and the grounding ring, resulting in leakage.

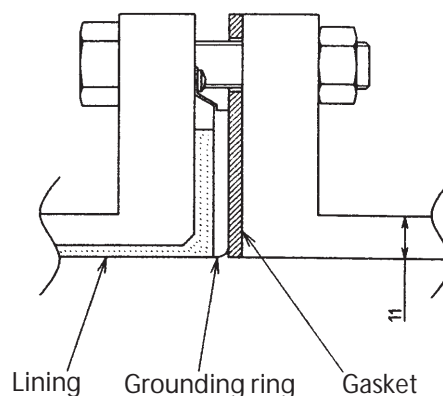

Figure 2-27 Installation using SUS material grounding rings

Installation on metal pipe (2)

Introduction

The installation method described in this section is to be used with the following grounding ring materials. For the installation method used with grounding rings of SUS material, refer to the table on page 2-29.

Pipe material: metal

Grounding ring material: Non-SUS material

Required accessories

The following parts are required. No gaskets are necessary since PTFE gaskets are provided.

- Bolts and nuts

Installation procedure

- Install the detector as shown in Figure 2-28. See Table 2-5 on page 2-26 for the appropriate fastening torque.

⚠ CAUTION

Please note that the use of an additional gasket besides the existing PTFE gasket may result in leakage (see Figure 2-29).

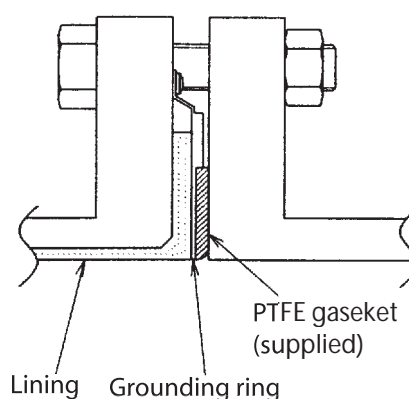

Figure 2-28 Installation using Non-SUS material grounding ring

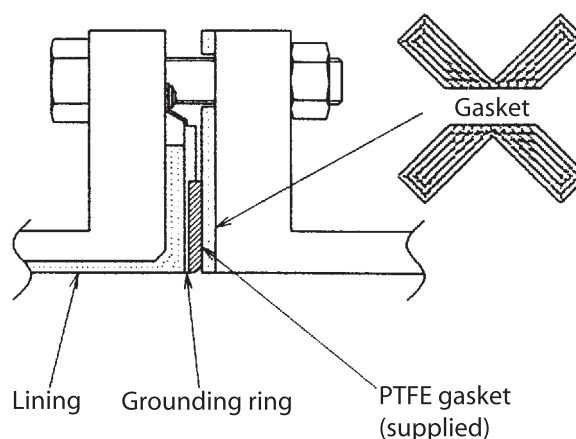

Figure 2-29 Example of incorrect installation

Installation on PVC pipe (1)

Introduction

The installation method described in this section is used for the following combination of pipe and grounding ring materials. For the installation method corresponding to any other combination, refer to the table on page 2-29.

Pipe material: PVC

Grounding ring material: SUS material

Required parts

The following parts are required:

- Through-bolts and nuts
- Gaskets: Non-rubber gaskets are recommended (i.e. joint sheet or PTFE). See Table 2-6 on page 2-28 for the recommended bore diameters. When using rubber gaskets, another gasket of the same material and with a thickness of 0.5 to 1.0 mm is required. See Table 2-3 on page 2-15 for the appropriated dimensions.
- Protective plate: Use a protective plate if bolt tightening to the specified torque threatens to warp or damage the PVC pipe. The plate material must be metal (such as stainless steel at least 6 mm thick) that will not deform when the nuts are tightened. For the shape of the protective plate, see Figure 2-31.

Installation procedure

The installation procedure varies depending on conditions such as the fastening torque and the need for a protective plate. Choose one of the following three methods as applicable.

1. Use this method to install the detector to the specified fastening torque.
Install the detector as shown in Figure 2-30. The torque level for tightening the bolts is not related to the gasket material. See Table 2-5 on page 2-26 for the appropriate torque. For the internal diameter of the gaskets, see Table 2-2 on page 2-15.

⚠ CAUTION

Please note that the use of rubber gaskets and a lower fastening torque may result in insufficient surface pressure between the lining and the grounding ring, resulting in leakage.

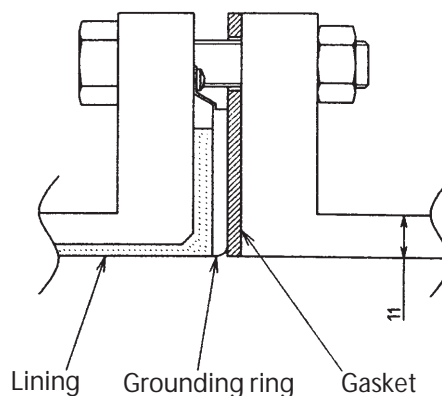

Figure 2-30 Installation using SUS material grounding ring

- Use this method to install the detector using a protective plate to prevent PVC pipe from being deformed or damaged when the bolts are tightened to the specified torque.

Install the protective plate between the outer side of the PVC flange and the detector, as shown in Figure 2-31. The protective plate protects the PVC pipe from deformation or damage when secured at the specified torque. The torque level is unrelated to the pipe or grounding ring material. See Table 2-5 on page 2-26 for the appropriate torque. For the internal diameters of the gaskets, see Table 2-6 on page 2-28.

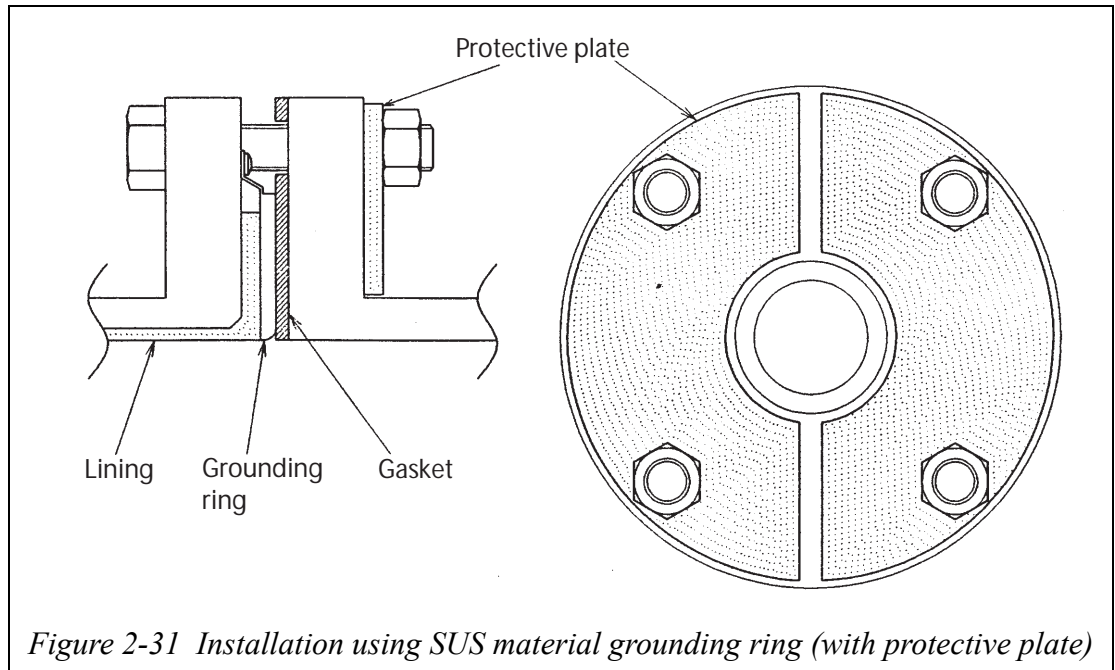

Figure 2-31 Installation using SUS material grounding ring (with protective plate)

- Use this method to install the detector using a low-fastening torque and rubber gaskets.

Remove the grounding ring from the detector, insert a rubber gasket 0.5 to 1.0 mm thick between the lining and the grounding ring, then reinsert the grounding ring. Then remove the PTFE gasket, and attach a gasket 3 to 4 mm thick instead. Under these conditions, attach the detector to the pipe as shown in Figure 2-32. Fasten the bolts to a torque that provides a leakproof joint

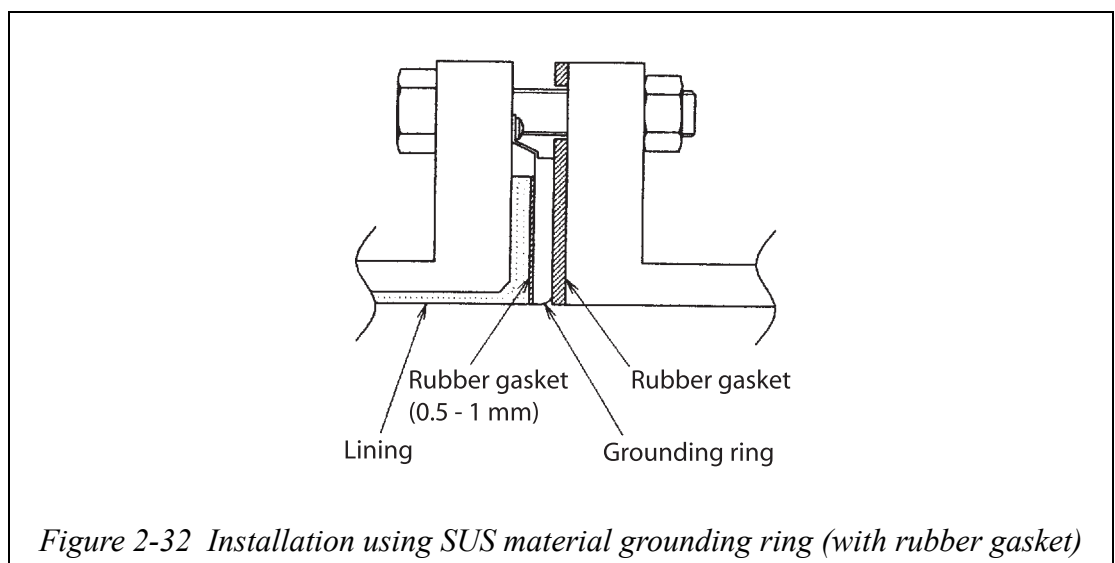

Figure 2-32 Installation using SUS material grounding ring (with rubber gasket)

Installation on PVC pipe (2)

Introduction

The installation method described in this section is to be used for the following combination of pipe and grounding ring materials. For the installation method used for any other combination, refer to the table on page 2-29.

Pipe material: PVC

Grounding ring material: Non-SUS material

Required parts

The following parts are required:

- Through-bolts and nuts
- Gaskets: No gaskets are necessary due to the provision of a PTFE gasket. When using a rubber gasket, two gaskets of the same material and of two thicknesses, 0.5 to 1.0 mm and 3.0 to 4.0 mm, are required. See Table 2-3 and 2-4 on page 2-15 for the appropriate dimensions.
- Protective plate: A protective plate is required if tightening the bolts to the specified torque may deform or damage the PVC pipe. Use stainless or hard metal 1 mm thick or more. For the shape of the metal, see Figure 2-31.

Installation procedure

The installation procedure varies depending on conditions such as the fastening torque and the need for a protective plate. Choose one of the following three methods as applicable.

1. Use this method to install the detector to the specified fastening torque. Install the detector as shown in Figure 2-33. See Table 2-5 on page 2-26 for the appropriate fastening torque. For dimensions of the rubber gaskets, see Table 2-3 and Table 2-4 on page 2-15

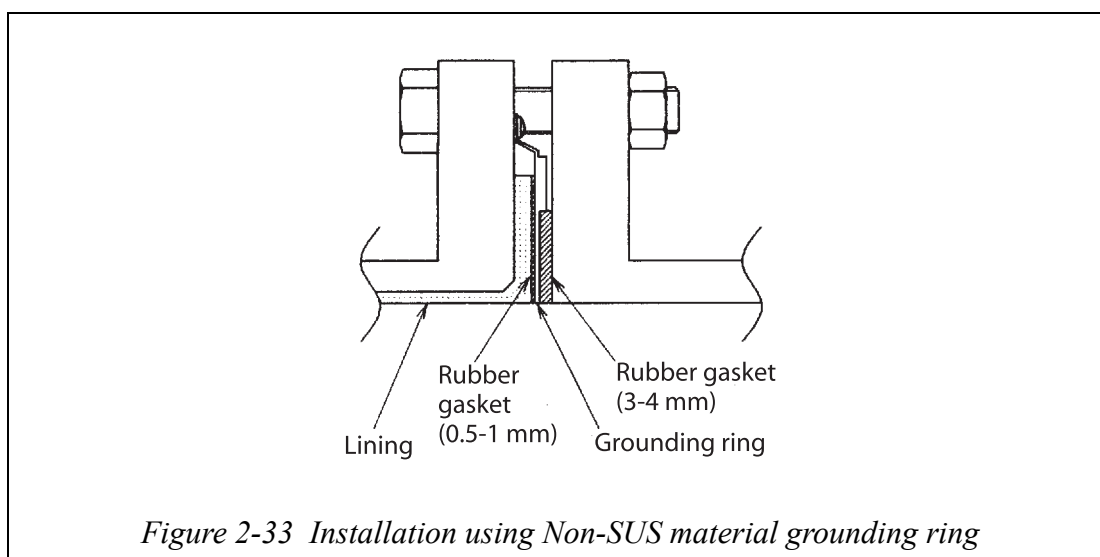

- Use this method to install the detector along with a protective plate to prevent PVC pipe from being deformed or damaged when the bolts are tightened to the specified torque.

Insert a protective plate between the outer side of the PVC flange and the detector as shown in Figure 2-34. The protective plate protects the PVC pipe from deformation or damage when it is secured to the specified torque. For the appropriate torque, see Table 2-5 on page 2-26.

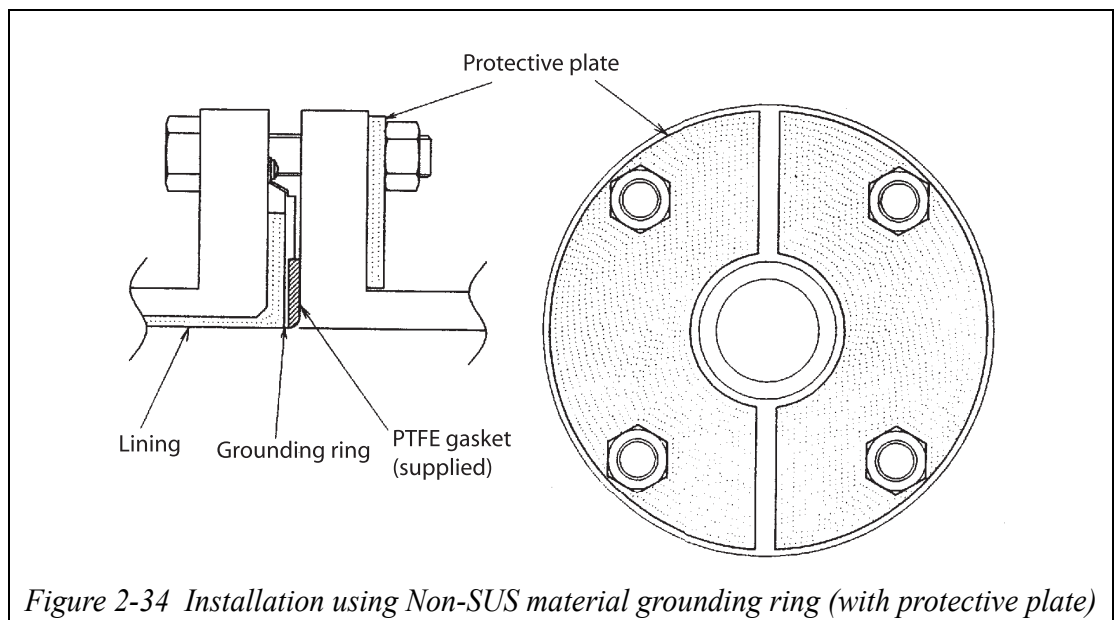

Figure 2-34 Installation using Non-SUS material grounding ring (with protective plate)

- Use this method to install the detector using a low fastening torque and rubber gaskets. First, remove the grounding ring from the detector, then insert a rubber gasket with a thickness of 0.5 to 1.0 mm. Then reinsert the grounding ring on top of the rubber gasket. Next, remove the PTFE gasket and insert a rubber gasket 3.0 to 4.0 mm thick to replace it. Under these conditions, install the detector on the pipe as shown in Figure 2-35. Tighten the bolts to the torque required to achieve a fluid seal for the rubber gasket. In this case, the two kinds of rubber gaskets that are used should be made of the same material. For the dimensions of the rubber gaskets, refer to Table 2-3 and Table 2-4 on page 2-15.

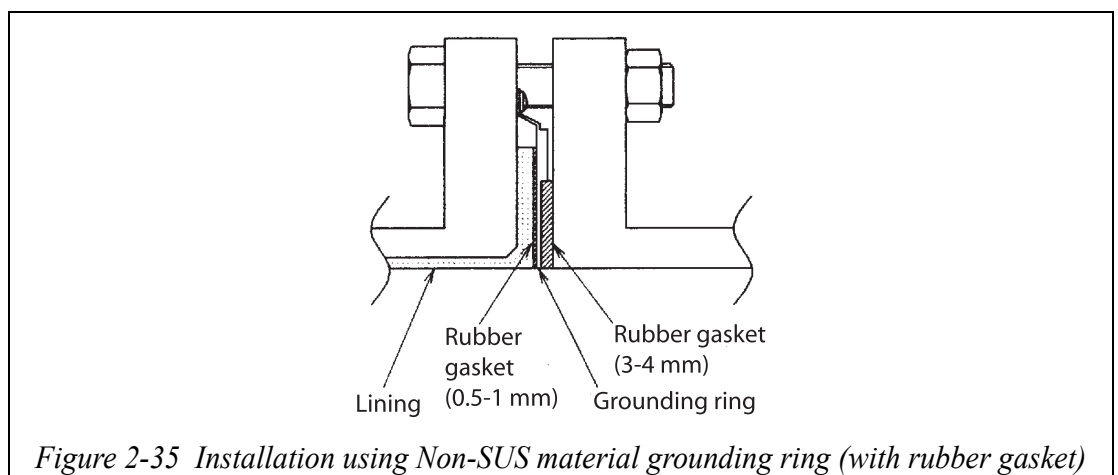
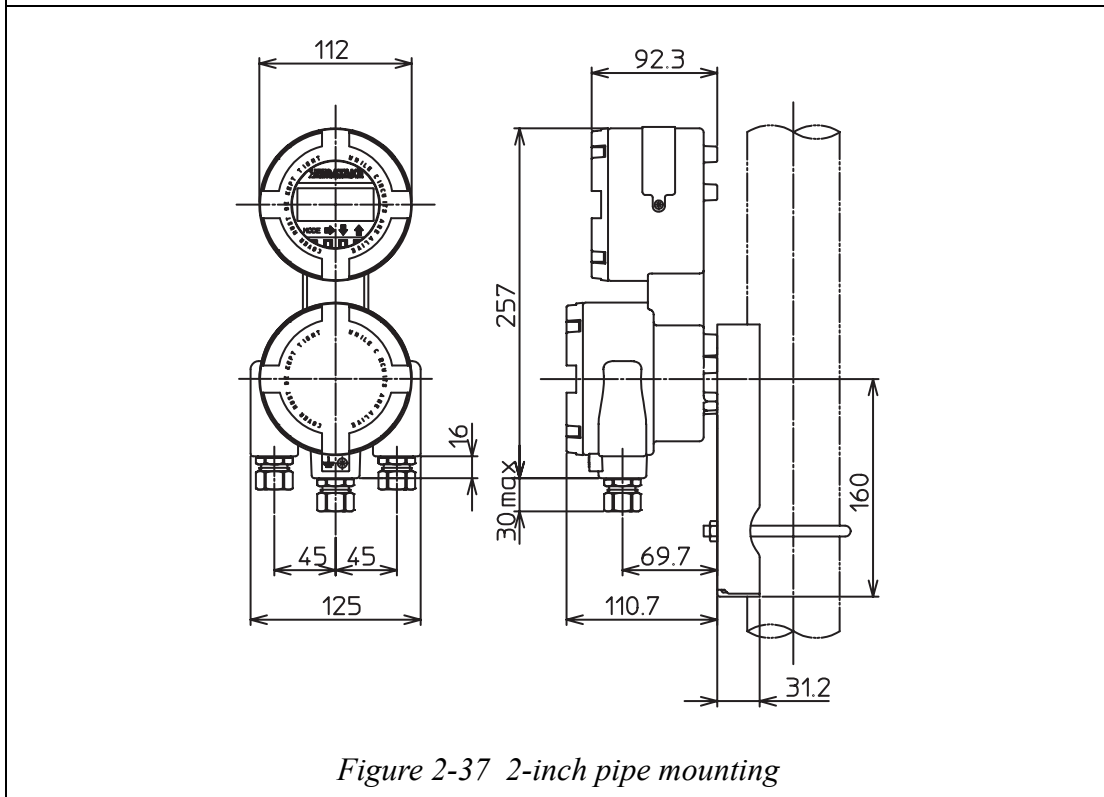
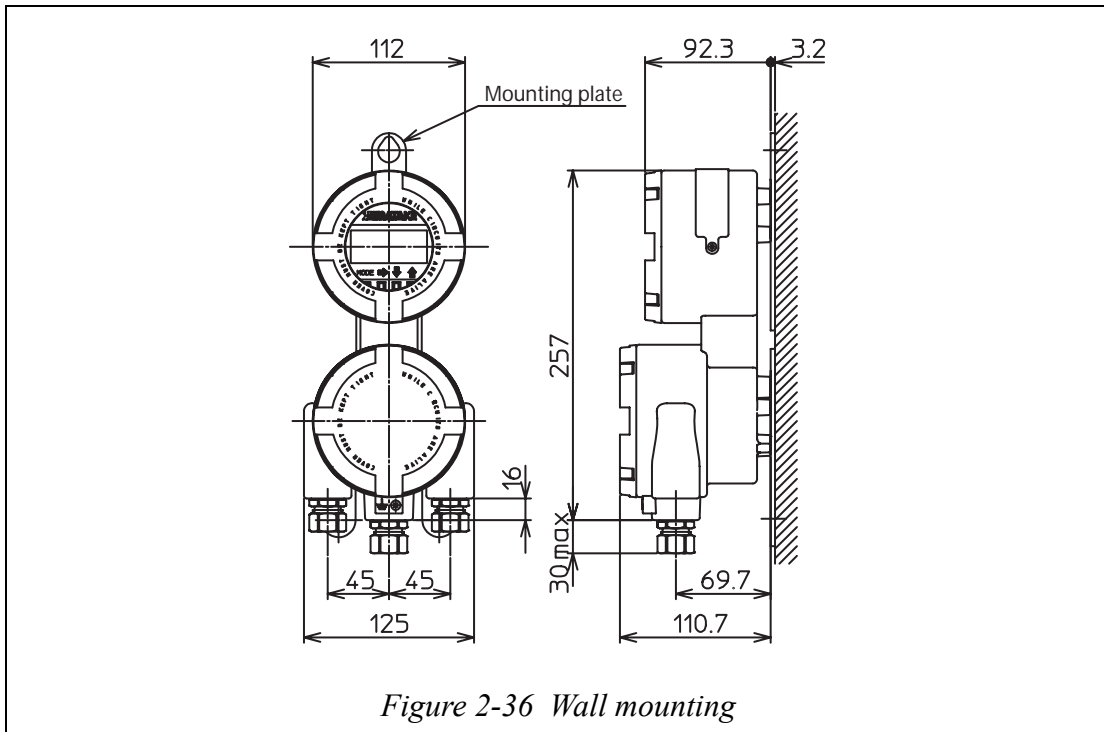

Figure 2-35 Installation using Non-SUS material grounding ring (with rubber gasket)

2-2-3 : Installation of remote-type converter

Basic installation

There are three methods of installations of the converter integral type, wall installation with the detector, and 2-inch pipe mounting.



Chapter 3 : Electrical wiring

Outline of this chapter

This chapter describes the electrical wiring of the main unit, SFC and HART Communicator.

3-1 : Electrical wiring

Electrical wiring

Introduction

For this instrument to operate, 15.3 to 42V DC power supply is required to signals wiring. The electrical wiring of this instrument is described below as to the following items:

- Wiring cable connecting positions
- Dedicated cable connecting positions (detector and converter)
- Power source and load resistance
- Cable selection and cabling
- Grounding
- Wiring connection of power supply and analog current output
- Wiring connection for pulse output
- Wiring connection for contact output
- Wiring procedure
- Wiring connection between detector and converter

~Note *Do not connect commercial power directly to this instrument. Impressing commercial power on this instrument causes unrecoverable damage to the internal measuring circuit.*

Power and load resistance

Use a direct current (15.3 to 42V DC) for the power.

Supply 50V DC or over or 35V AC or over causes unrecoverable damage to the instrument.

The power ripple factor should be 1V or less in peak-to-peak value.

See that the load resistance of the loop wiring should within the operational range shown in Figure 3-1-1 with respect to the power supply voltage used.

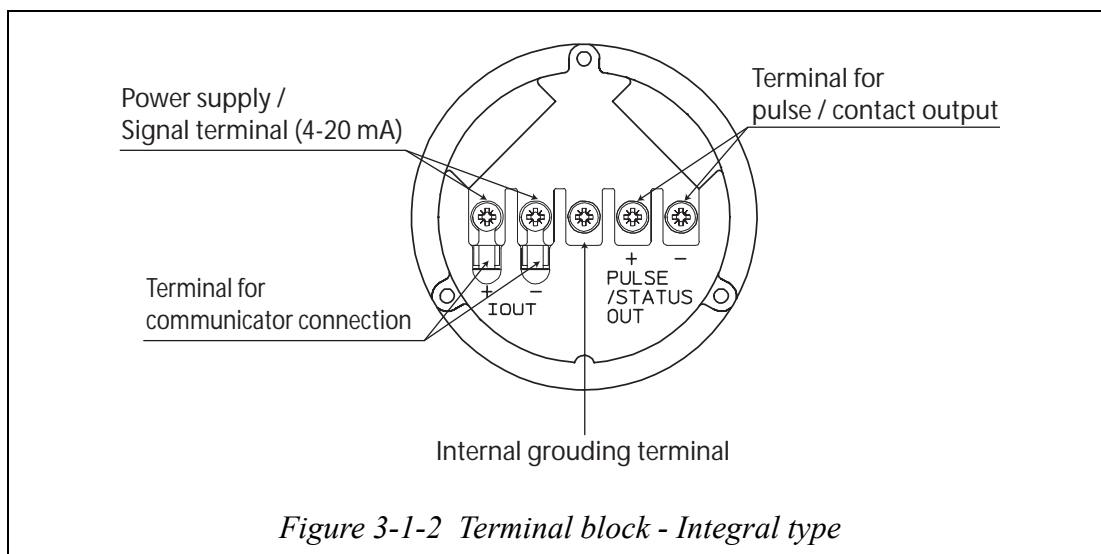
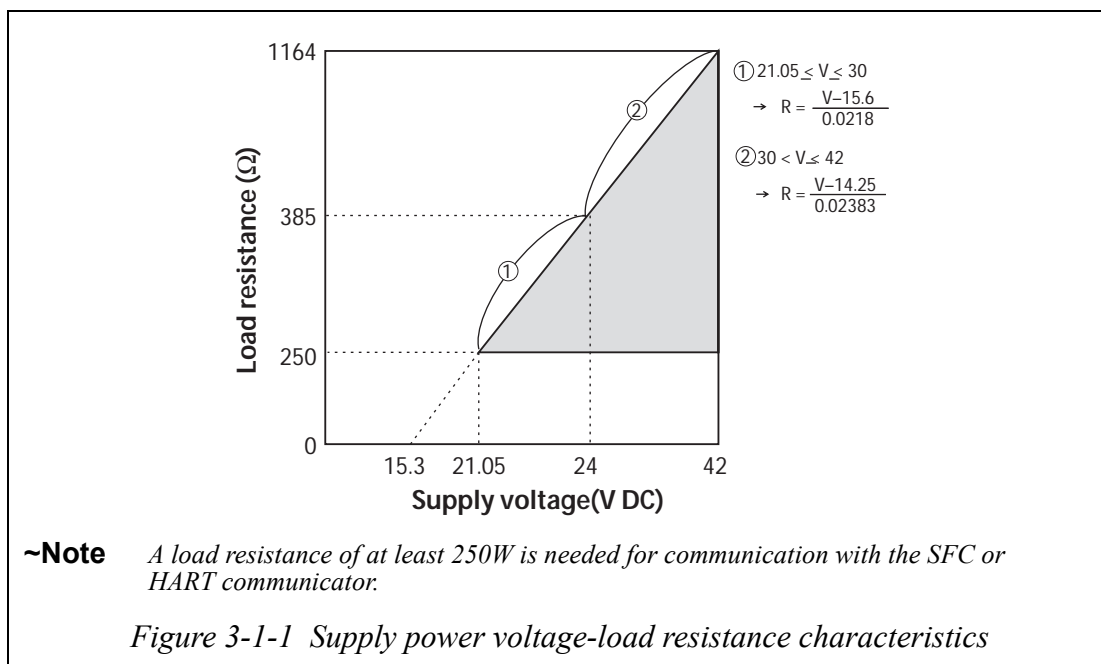

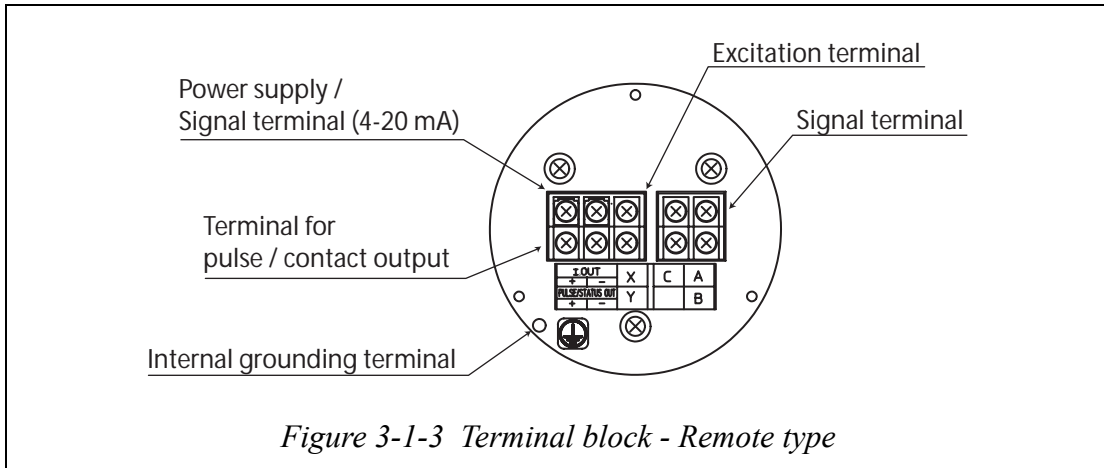

Selecting the wiring cable

For the electrical cable, we recommend 600V vinyl insulation, vinyl sheath wire CVV with a conductor area of 2 mm² or a stranded wire cable having equivalent or superior performance.

To avoid influences or damages due to electromagnetic induction, we recommend using two core shielded cables for wiring.

Select a sheath material that can endure the environment (ambient temperature, corrosive gas, corrosive fluid and the like) in which the cable is running.

The cable is wired in to the terminal box through a conduit cable ground (with G1/2 internal thread, CM20 internal thread or 1/2NPT internal thread). Therefore, the optimum cable external diameter is $\phi 11$.

For the terminal treatment of the cable, we recommend a crimp terminal (M4 screw) with an insulating sleeve.

The maximum length of wiring cable is 1500 meters.

Cabling

When running a cable between the instrument and a controller, pay attention to the following:

- The cabling should avoid a large-capacity transformer, motor, power source or other noise source. Do not put the cable in the same tray or duct with other power cables.
- For waterproofing and damage prevention of the wire, we recommend cabling work using conduits and ducts. Use a waterproof gland at the conduit cable ground.

Grounding (integral type)

The grounding is essential for flow measurement.

The most effective grounding method is direct connection to earth ground with minimal impedance.

For the grounding terminal, carry out grounding work (grounding resistance 100Ω or less) according to Figure 3-2 or Figure 3-3. Do not ground internal & external at the same time.

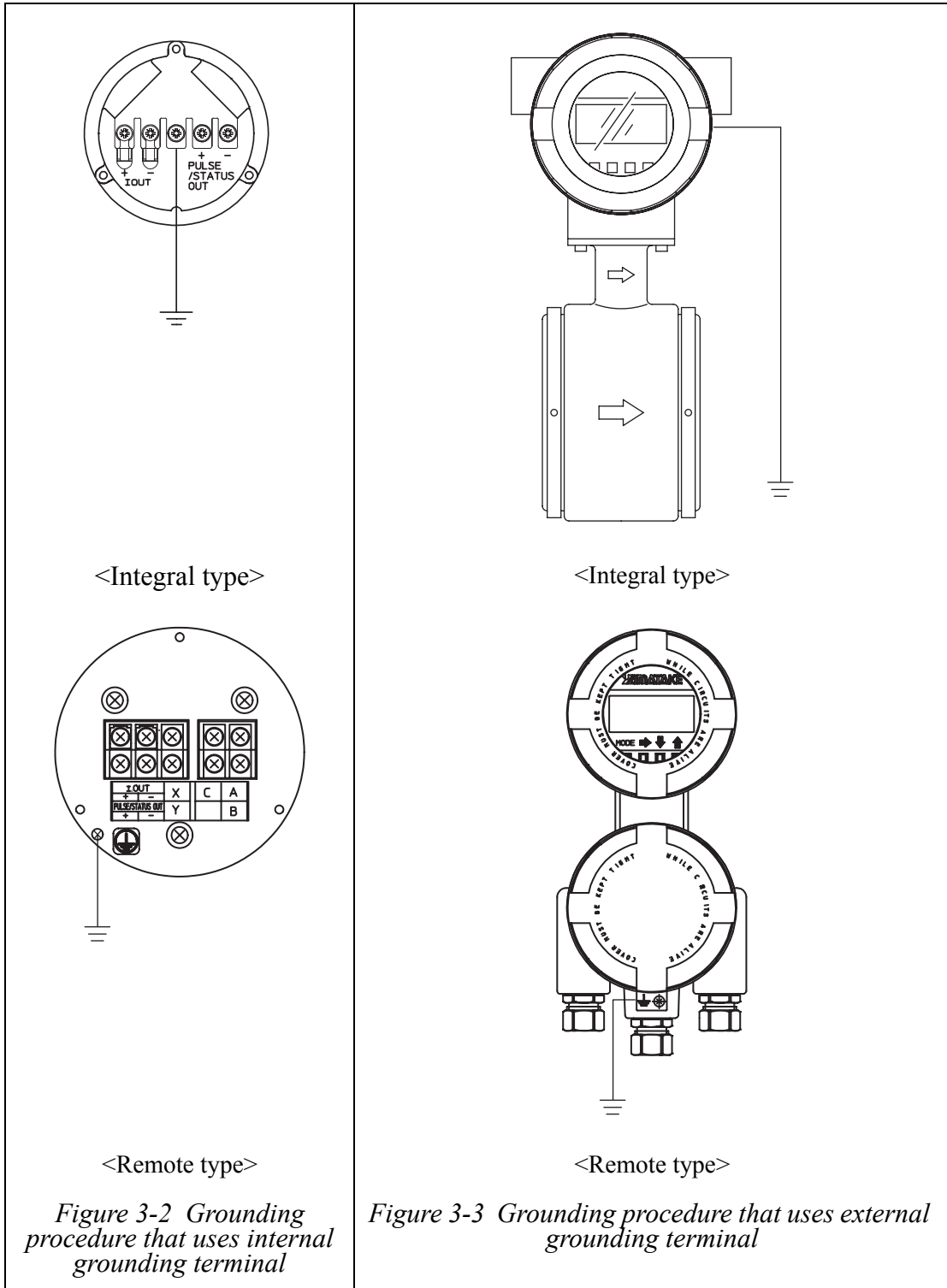

Wiring connection of power supply and analog current output

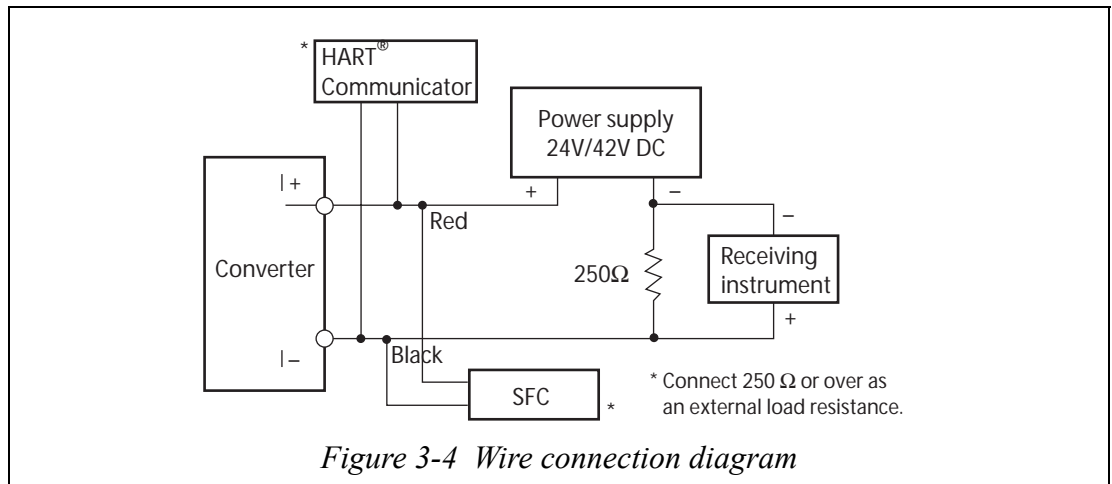

Input circuit such as sequence controllers

It must use 4-20 mA such as sequence controllers and the input to the equipment with A/D at high speed must use the following optional circuits.

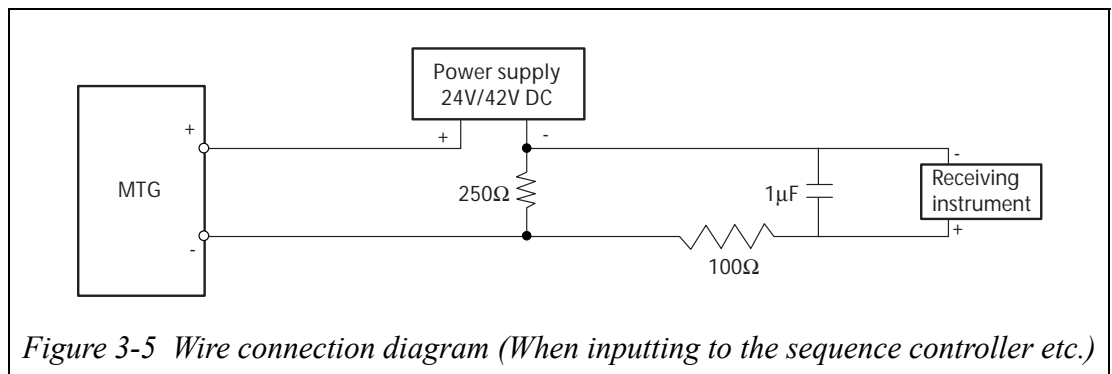

⚠ CAUTION

- Incorrect wiring polarity can cause damage to the equipment. Double-check the wiring position.
- The SFC and HART Communicator cannot be used simultaneously.
- Only the communication method selected by the data setting device is available.

Wiring connection for pulse output

The pulse output is an open-collector output.
Carry out the wiring paying attention to the voltage and polarity.

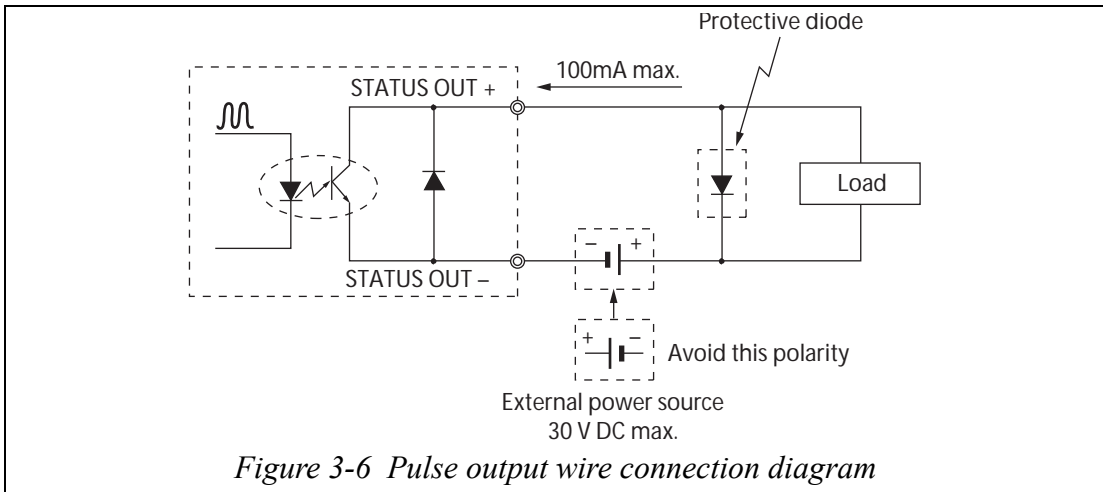

⚠ CAUTION

- Incorrect wiring polarity can cause damage to the equipment. Double-check the wiring position.
- Use an external power source that meets the voltage and capacity specifications.

Wiring connection for contact output

Because of an open-collector output, carry out wiring paying attention to the polarity.

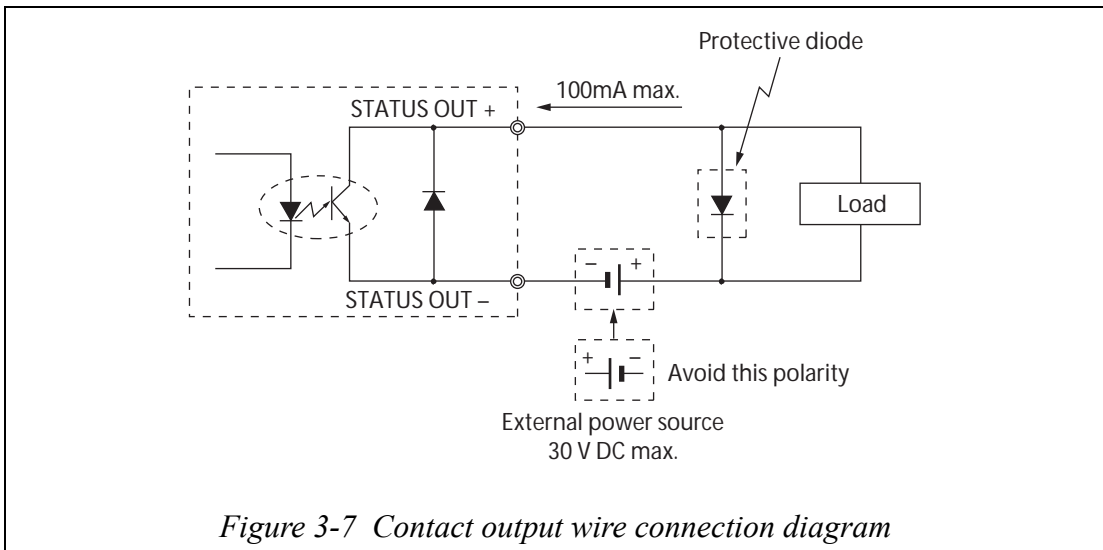

⚠ CAUTION

- Incorrect wiring polarity can cause damage to the equipment. Double-check the wiring position.
- Use an external power source that meets the voltage and capacity specifications.

Wiring procedure

Carry out the wiring between the instrument and a power supply must be done according to the following procedure.

Step	Procedure
1	The terminal box cover is fixed by hexagon socket head setscrews (M3). Loosen the setscrews with an Allen wrench (1.5).
2	Remove the terminal box cover by turning it counterclockwise with the dedicated tool.
3	Remove the dust plug from the socket for an output signal line conduit.
4	Insert the cable into the conduit cable ground. ~Note • Take care not to damage the cable sheath.
5	Referring to Figure 3-6, connect the cable to the output signal terminals (IOUT+, -) of the terminal box. ~Note • Pay attention to the polarity. • Tighten the terminal screws adequately. The recommended tightening torque is 1.1 ft-lb (1.5 N·m)*.
6	Waterproof the conduit sufficiently to prevent ingress of rainwater, etc. ~Note • We recommend using a silicon resin-based non-curing sealant.
7	Attach the terminal box cover and tighten it adequately with the dedicated tool. Then, fix the cover with the setscrews. ~Note • Take care not injure your fingers on the cover edge or the carrying thread.

*: The numerical value in parentheses is a reference value.

Wiring for power supply

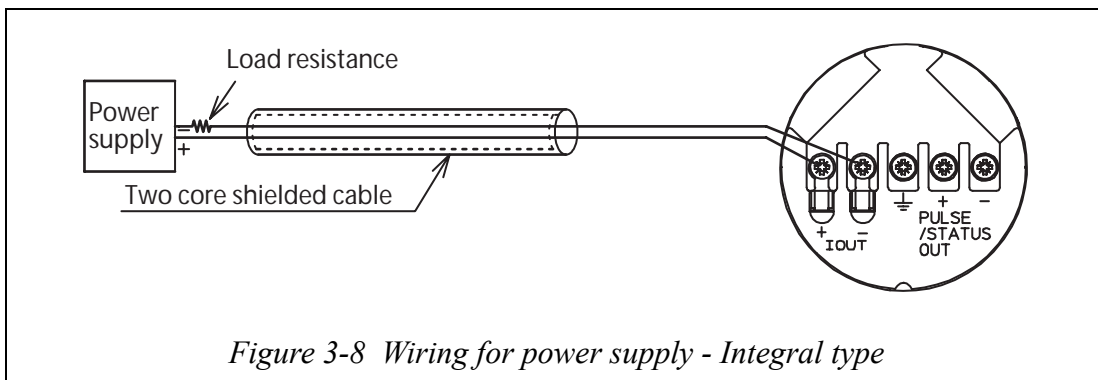

Figure 3-8 Wiring for power supply - Integral type

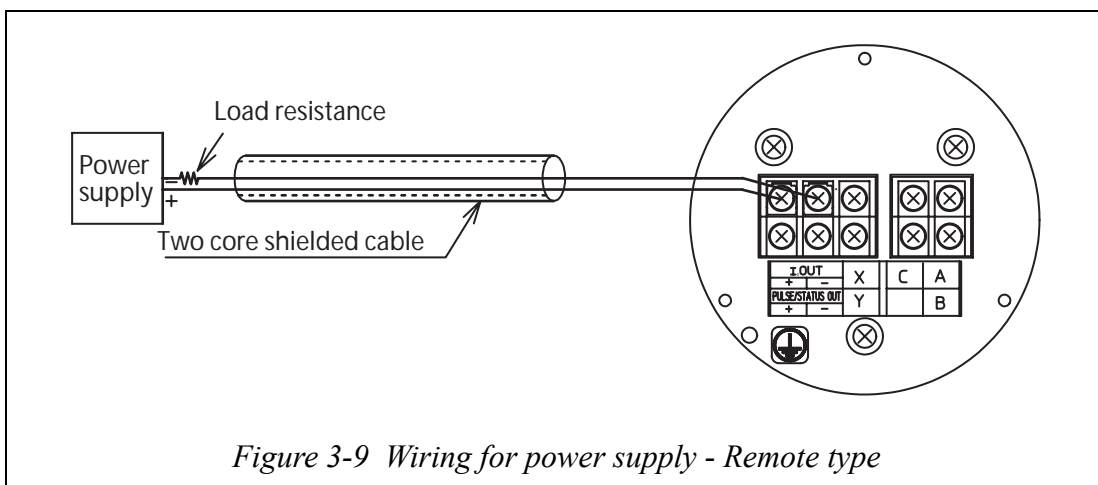

Figure 3-9 Wiring for power supply - Remote type

Wiring connection between detector and converter

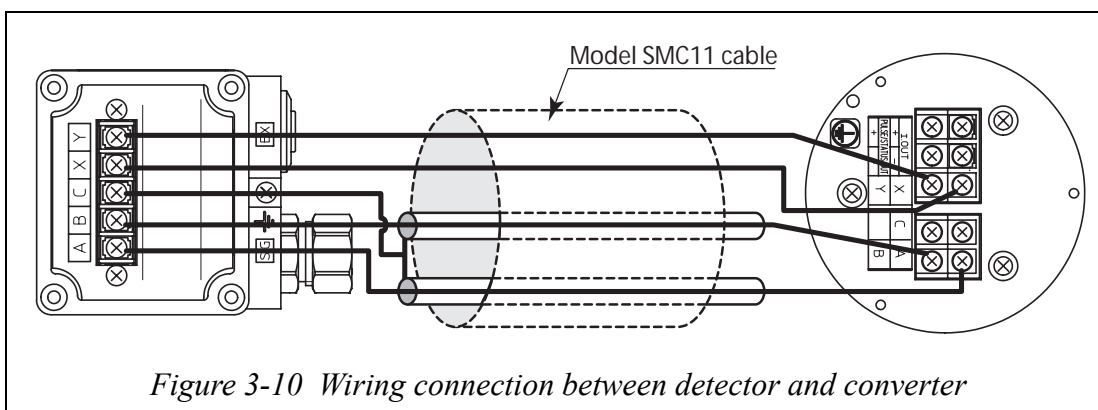

Figure 3-10 Wiring connection between detector and converter

Please use model SMC11 cable for wiring connection between detector and converter.

Chapter 4 : Operation

Outline of this chapter

This chapter describes the procedure for start-up of the instrument and making zero adjustment. It also describes termination of measuring system.

When starting up and operating the instrument for the first time, carefully follow the descriptions in this chapter.

4-1 : Confirmation before start-up

Introduction

Before you start up the instrument, confirm the following items. Numbers in parentheses indicate the chapter to refer.

- (1) Confirm that the electromagnetic flowmeter is installed correctly in the pipes (Chapter 2 : Instrument installation).
- (2) Confirm that the electrical wiring is correct (Chapter 3 : Electrical wiring).
- (3) If communication is required, confirm that the communication equipment is wired correctly (Chapter 3 : Electrical wiring).
- (4) Fill the electromagnetic flowmeter detector with a fluid and reform zero adjustment in a static state (Chapter 5 : Operation using the data setting device).
- (5) Confirm that there is no leakage at the joint of the electromagnetic flowmeter's detector (Chapter 2 : Instrument installation).
- (6) Confirm that the electromagnetic flowmeter detector is filled with water and there are no stagnant bubbles.
- (7) Turn on power and warm up for 30 minutes.
- (8) Confirm whether the settings of the data sheet inserted in the converter have been setup and configured. If there is need to change settings to meet your usage, change them using the data setting device or the like.

- ~Note**
- *If the detector is not filled with water or many bubbles have adhered inside, the indication may not reach zero flow rate. In such cases, make a flow of water once to ensure that the detector is free of bubbles and filled with water.*
 - *With incorrect grounding, the indication of flow rate may fluctuate largely. In such cases, check the grounding condition.*

4-2 : Stopping

Caution



When stopping the instrument from operation and shutting down the output to control equipment, always change over the control equipment to manual control. This is for preventing the instrument's output shutdown from directly influencing the control equipment.

Procedure

When stopping the instrument, follow the following procedure:

Step	Procedure
1	Change over the control equipment of this instrument to be stopped to manual control.
2	Turn off power.

Chapter 5 : Operation using the data setting device

This section describes how to operate this system from the data setting device. This system configuration and settings can be made using the four keys on the data setting device.

5-1 : Startup

Introduction

With the model MTG, all settings can be configured from the data setting unit.

Startup

When the power supply is turned on, the display changes in the order of OVERALL DISPLAY, SELF CHECK MODE, and MEASURING MODE.

OVERALL DISPLAY

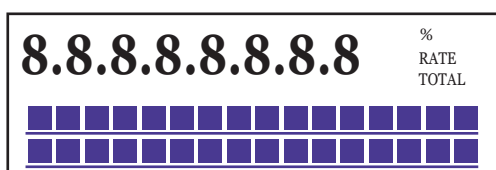

8.8.8.8.8.8.8.8
 Main display: 7-segment, 8-digit display
 % flow rate Actual flow rate Integration value
 ■■■■■■ Unit display
 ■ Sub-display Display screen for setting
 Displayed for 2 seconds.



SELF CHECK MODE



Main display 7-segment, 8-digit blinks.
 The display (-) moves from left to right.
 Sub display: SELF CHECK MODE
 Displayed for 5 seconds



MEASURING MODE

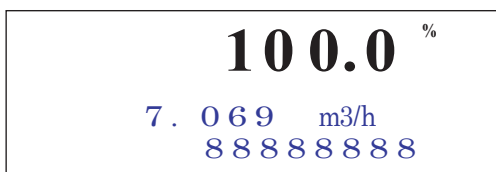

Display and operation contents of data setting device

Overview of mode

This system provides the following four modes available in accordance with the operations:

Mode	Description
MEASURING MODE	Mode that shows measuring status.
OPERATOR'S MODE	<p>Mode that is set for the operator. This mode is comprised of setting and configuration of data that are set or changed frequently during startup. In this mode, settings can be changed only when the write protect levels are set to 0, 1 and 2. At level 3, only the set data can be checked. (See "5-3-2 : Display of write protect level")</p> <p>[Damping constant, auto zero adjustment, counter reset, counter preset value, etc.]</p> <div data-bbox="794 779 1449 1070" style="border: 1px solid black; padding: 5px;"> <p style="text-align: center;">⚠ CAUTION</p> <p>Set or changed data are temporarily written into the memory. Note that if the configured data are not saved/written into the memory within 10 minutes, the configured data returns to the previous values. Be sure to press the MODE key to return to the MEASURING MODE and to save data.</p> </div>
ENGINEERING MODE	<p>In the set mode for engineering, the mode is comprised of data that is set or changed less frequently than the data in "OPERATOR'S MODE."</p> <p>Data can be set and changed at write protect level 0 or 1. At level 2 or 3, only the set data check is allowed.</p> <p>[ID, function selection, detector data, flow rate range, hysteresis width, pulse data, low flow cut, selecting false mode for output, etc.]</p> <div data-bbox="794 1406 1449 1899" style="border: 1px solid black; padding: 5px;"> <p style="text-align: center;">⚠ CAUTION</p> <ul style="list-style-type: none"> • When the mode is changed to MEASURING MODE by pressing the MODE key, the set/changed data are saved into a non-volatile memory. Be sure to press the MODE key, to save the configured data. • Set or changed data are temporarily written into the memory. Note that if the configured data are not saved/written into the memory within 10 minutes, the configured data returns to the previous values. Be sure to press the MODE key to return to the MEASURING MODE and to save data. </div>

Mode	Description
<p>MAINTENANCE MODE</p>	<p>A mode for maintenance that is used when adjustments and checks are needed for regular maintenance and when troubles occur. Adjustments and checks are allowed only at write protect level 0. [Loop check, output adjustment, gain adjustment, etc.] This mode is furthermore divided into the following three types: OUTPUT CHECK MODE CALIBRATION MODE CRITICAL MODE</p> <div data-bbox="700 573 1353 862" style="border: 1px solid black; padding: 5px;"> <p style="text-align: center;">⚠ CAUTION</p> <ul style="list-style-type: none"> • CALIBRATION MODE and CRITICAL MODE contains very important adjustment values or operations for the flow rate measurement. Wrong settings make accurate flow rate measurement impossible. For the operation, contact our service engineers. </div> <div data-bbox="700 900 1353 1391" style="border: 1px solid black; padding: 5px; margin-top: 10px;"> <p style="text-align: center;">⚠ CAUTION</p> <ul style="list-style-type: none"> • When the mode is changed to MEASURING MODE by pressing the MODE key, the set/changed data are saved into a non-volatile memory. Be sure to press the MODE key, to save the configured data. • Set or changed data are temporarily written into the memory. Note that if the configured data are not saved/written into the memory within 10 minutes, the configured data returns to the previous values. Be sure to press the MODE key to return to the MEASURING MODE and to save data. </div>

5-2 : Functions of the data setting device

5-2-1 : Data setting device

Name of parts

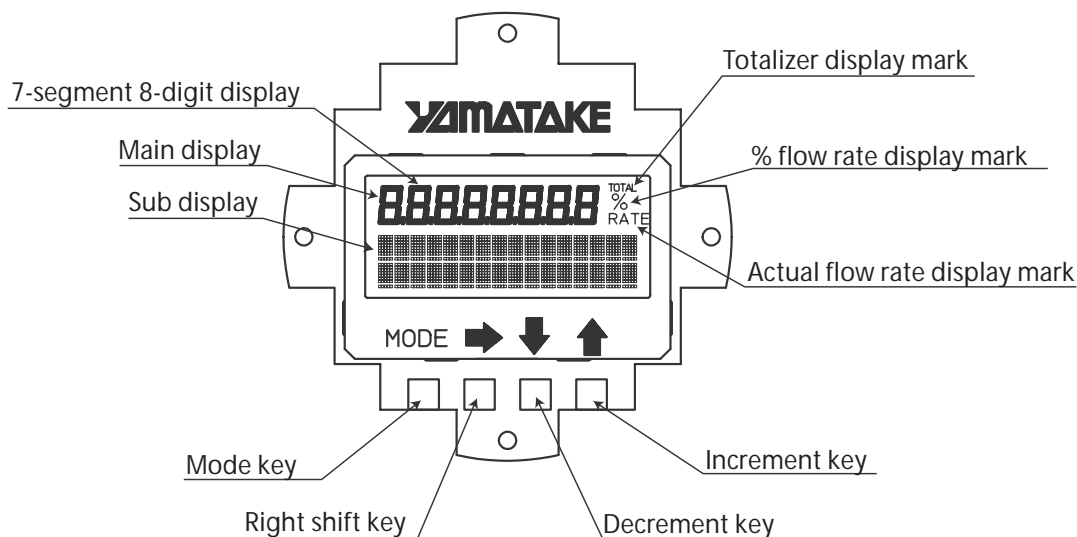

Names and Descriptions of Parts

This section describes displays shown on the data setting device.

- Flow rate display

The flow rate display is given at three stages: % flow rate, actual flow rate and totalized value. Operating the key, the main display to be shown at the top stage can be set selecting from the actual flow rate, % flow rate and totalized value. RATE appears for the actual flow rate display, % for the % flow rate display, and TOTAL for the totalized value display (see “5-3-1 : Display overview”).



Area	Description
Main display 7-segment 8-digit display	Displays the flow rate display selected for the main display by DISP SELECT in OPERATOR'S MODE.
% flow rate display mark (%)	Displays when % flow rate is shown for the main display.
Actual flow rate display mark (RATE)	Displays when the actual flow rate is shown for the main display.
Totalized value display mark (TOTAL)	Displays when the totalized value is shown for the main display.
Sub display	<ul style="list-style-type: none"> In MEASURING MODE, shows a flow rate display other than a flow rate display selected for the main display by DISP SELECT in OPERATOR'S MODE. In modes other than MEASURING MODE, indicate procedures for setting and adjusting parameters.

This section describes keys on the data setting device.

Name	Description
MODE key	<ul style="list-style-type: none"> Enters OPERATOR'S MODE. When parameters and configured data have been changed in ENGINEERING MODE or MAINTENANCE MODE, press this key to save the data.
Right shift key	<ul style="list-style-type: none"> Moves the cursor to the right.
Decrement key	<ul style="list-style-type: none"> Changes the parameter at a cursor position. Displays the previous screen. <div style="display: flex; justify-content: space-between; align-items: flex-start;"> <div style="border: 1px solid black; padding: 5px; width: 200px;"> <p>* OPERATOR'S MODE</p> <p>Cursor</p> </div> <div style="width: 60%;"> <p>If the key is pressed, when the cursor is placed at the upper left end (*, #, >), the screen will change</p> </div> </div> <div style="display: flex; justify-content: space-between; align-items: flex-start; margin-top: 10px;"> <div style="border: 1px solid black; padding: 5px; width: 200px;"> <p>* DAMPING 001.0 S</p> <p>Cursor</p> </div> <div style="width: 60%;"> <p>If the key is pressed, when the cursor is placed at a number, the number is decremented.</p> </div> </div> <div style="display: flex; justify-content: space-between; align-items: flex-start; margin-top: 10px;"> <div style="border: 1px solid black; padding: 5px; width: 200px;"> <p># 1.0000 m/s SPAN 07_069 m³/h</p> <p>Cursor</p> </div> <div style="width: 60%;"> <p>If the cursor is placed at a decimal point, the decimal point moves rightward.</p> </div> </div>
Increment key	<ul style="list-style-type: none"> Changes the parameter at a cursor position. Displays the following screen. <div style="display: flex; justify-content: space-between; align-items: flex-start;"> <div style="border: 1px solid black; padding: 5px; width: 200px;"> <p>* OPERATOR'S MODE</p> <p>Cursor</p> </div> <div style="width: 60%;"> <p>If the key is pressed, when the cursor is placed at the upper left end (*, #, >), the screen will change.</p> </div> </div> <div style="display: flex; justify-content: space-between; align-items: flex-start; margin-top: 10px;"> <div style="border: 1px solid black; padding: 5px; width: 200px;"> <p>* DAMPING 001.0 S</p> <p>Cursor</p> </div> <div style="width: 60%;"> <p>If the key is pressed, when the cursor is placed at a number, the number is incremented.</p> </div> </div> <div style="display: flex; justify-content: space-between; align-items: flex-start; margin-top: 10px;"> <div style="border: 1px solid black; padding: 5px; width: 200px;"> <p># 1.0000 m/s SPAN 07_069 m³/h</p> <p>Cursor</p> </div> <div style="width: 60%;"> <p>If the key is pressed, when the cursor is placed at a decimal point, the decimal point moves to the left.</p> </div> </div> <div style="display: flex; justify-content: space-between; align-items: flex-start; margin-top: 10px;"> <div style="border: 1px solid black; padding: 5px; width: 200px;"> <p>* AUTO ZERO READY</p> <p>Cursor</p> </div> <div style="width: 60%;"> <p>If the cursor is placed over READY, pressing the key starts operation.</p> </div> </div>

5-3 : Description of MEASURING MODE

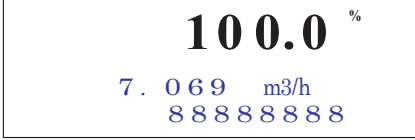
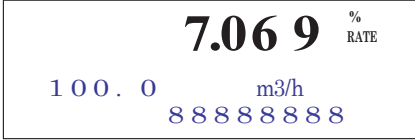
5-3-1 : Display overview

<p>% flow rate display</p> 	<p>1st line (Main display): 7-segment 4-digit display % flow rate (%)</p> <p>2nd line: Actual flow rate display (Significant value of 5 digits)</p> <p>3rd line: Totalized value display (Significant figure of 8 digits)</p> <p>Write protect level display (WP0 to 3)</p>
<p>Actual flow rate display</p> 	<p>1st line (Main display): 7-segment 4-digit display Actual flow rate (RATE)</p> <p>2nd line: % flow rate display (Significant figure of 4 digits), unit of actual flow rate</p> <p>3rd line: Totalized value display (Significant figure of 8 digits)</p> <p>Write protect level display (WP0 to 3)</p>
<p>Totalizer display</p> 	<p>1st line (Main display): 7-segment 8-digit display Totalized value (TOTAL)</p> <p>2nd line: Actual flow rate display (Significant figure of 4 digits)</p> <p>3rd line: % flow rate display (Significant figure of 4 digits)</p> <p>Write protect level display (WP0 to 3)</p>

Totalization is not performed, when the output selection is set to the contact output. However, the previous value is displayed as the totalized value.

* Details on display

- % flow rate display:** The % flow rate display range is from -115.0% to 115.0%. A value up to the first decimal place is displayed. The position of the decimal point is fixed. The integer part to be displayed has up to three digits (0 to 115). In the main display, unnecessary zeros are deleted (but are not deleted in the sub display).
 Example) 019.8% → 19.8%
 -000.5% → -0.5%
- The position of the negative sign (-) is fixed. (The positive sign is not displayed.)
- Actual flow rate display:** The flow rate displayed in the actual flow rate display is up to 115% of the range or the equivalent. However, if the flow rate equivalent to 115% of the range exceeds the range of significant figure, the highest value (e.g., 9.999) will be displayed. In the main display, unnecessary zeros are deleted (but are not deleted in the sub display).

Totalized value display: An totalized value is displayed in 8 digits without signs and decimal points.

In the main display, unnecessary zeros are deleted (but are not deleted in the sub display).

Next to 99999999, totalization starts from 00000000.

5-3-2 : Display of write protect level

Protect level

The write protect levels and their corresponding settings and operating condition are shown below.

Write protect level	SW1	SW2	LSC (Key operation)			Communication		
			OPERATOR'S MODE	ENGINEERING MODE	MAINTENANCE MODE	OPERATOR'S MODE	ENGINEERING MODE	MAINTENANCE MODE
0	OFF	OFF	R/W ENABLE	R/W ENABLE	R/W ENABLE	R/W ENABLE	R/W ENABLE	R/W ENABLE
1	ON	OFF	R/W ENABLE	R/W ENABLE	R/W ENABLE	R ONLY	R ONLY	R ONLY
2	OFF	ON	R/W ENABLE	R ONLY	R/W ENABLE	R ONLY	R ONLY	R ONLY
3	ON	ON	R ONLY	R ONLY	R/W ENABLE	R ONLY	R ONLY	R ONLY

R/W: Read and write (Reads and writes set values.)

R: Read

W: Write

ENABLE: Enabled

Disable: Disabled

ONLY: Only the indicated operation is enabled.

~Note *Be sure to turn off the power supply before changing the write protect level dip switch settings.*

Settings of write protect switches

SW No.	At shipment
S1	Determined by WP LEVEL.
S2	Determined by WP LEVEL.
S3	ON (No data change is allowed.)

Main board

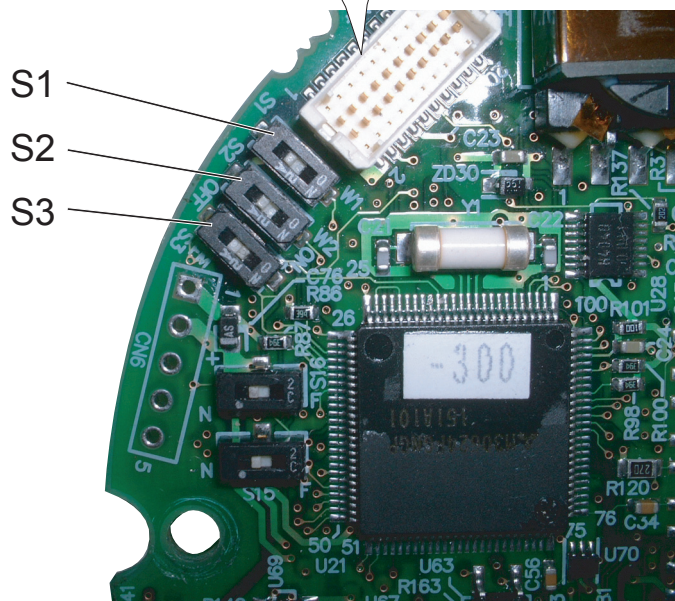
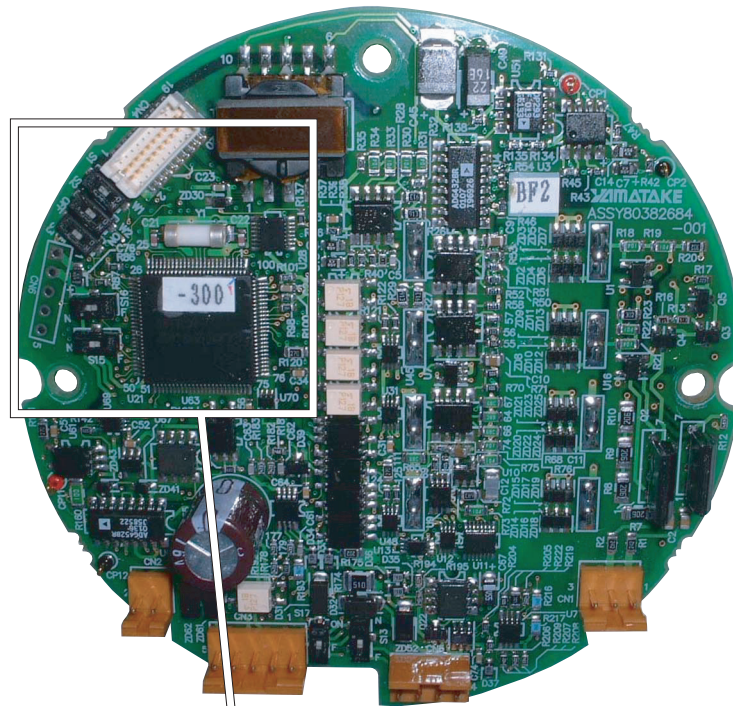

5-4 : Overview of operation using the data setting device

Introduction

The data setting device has three types of modes: OPERATOR'S MODE, ENGINEERING MODE, and MAINTENANCE MODE. MAINTENANCE MODE is furthermore divided into three of sub-modes: OUTPUT, CALIBRATION, and CRITICAL. The screen flow is as follows:

Entire display flow 1

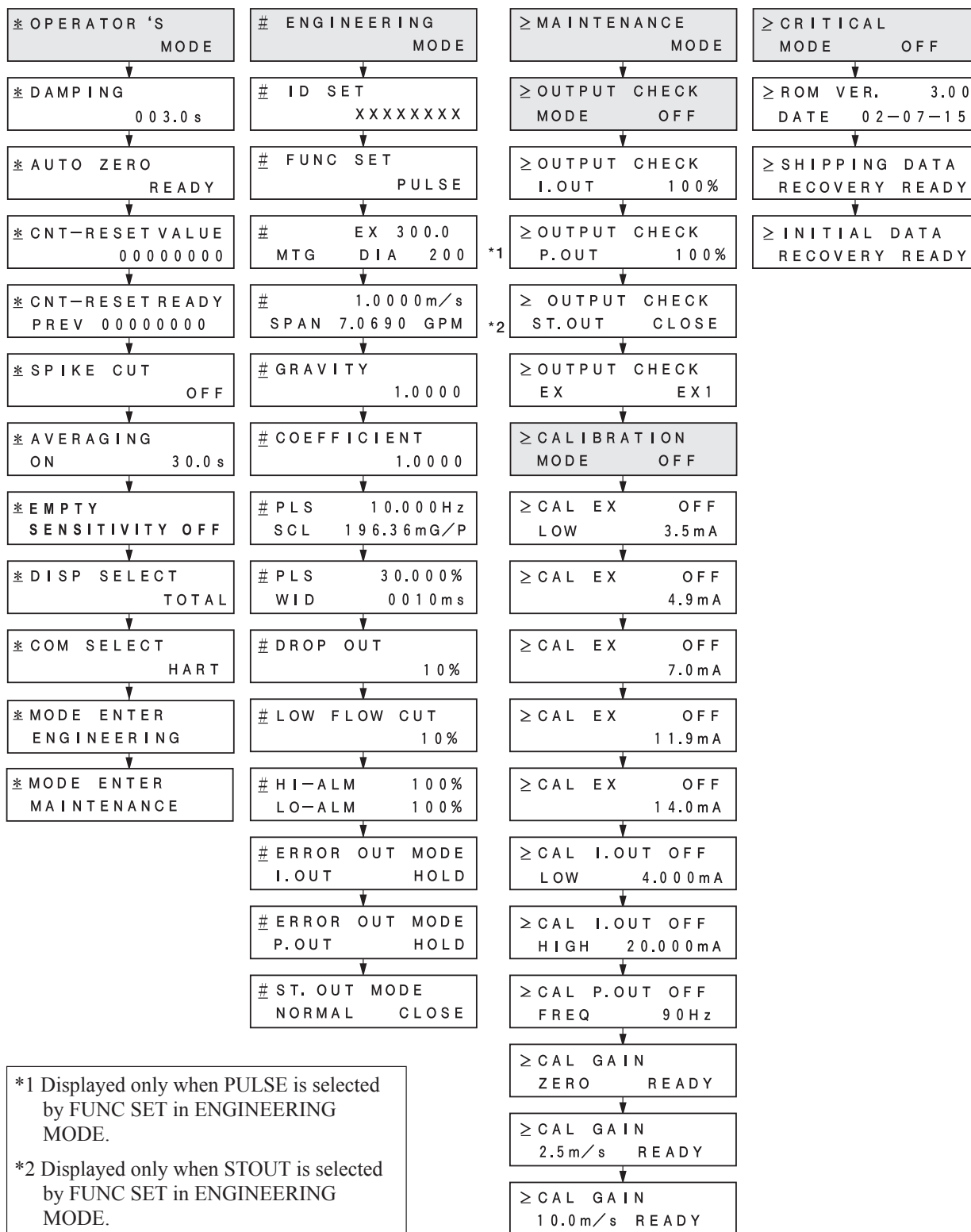

*1 Displayed only when PULSE is selected by FUNC SET in ENGINEERING MODE.
 *2 Displayed only when STOUT is selected by FUNC SET in ENGINEERING MODE.

5-5 : Configuration of OPERATOR'S MODE

Introduction

OPERATOR'S MODE provides the following setting and adjustment items.

For details on functions in the items, see “5-5-1 : Changing setting of damping time constant” and later.

Item	Contents	Screen
DAMPING	Sets a damping time constant.	<div style="border: 1px solid black; padding: 5px; text-align: right;"> 20.0 % * DAMPING 005.0 s </div>
AUTO ZERO	Auto zero adjustment	<div style="border: 1px solid black; padding: 5px; text-align: right;"> 20.0 % * AUTO ZERO READY </div>
CNT-RESET VALUE	Sets a built-in counter reset value.	<div style="border: 1px solid black; padding: 5px; text-align: right;"> 20.0 % * CNT-RESET VALUE 0 0 0 4 4 4 4 </div>
CNT-RESET READY	Resets totalized value to a built-in counter reset value.	<div style="border: 1px solid black; padding: 5px; text-align: right;"> 20.0 % * CNT-RESET READY 0 0 0 0 0 0 0 0 </div>
SPIKE CUT	Sets auto spike cut.	<div style="border: 1px solid black; padding: 5px; text-align: right;"> 20.0 % * SPIKE CUT OFF </div>
AVERAGING	Sets a moving average function.	<div style="border: 1px solid black; padding: 5px; text-align: right;"> 20.0 % * AVERAGING OFF </div>
DISP SELECT	Selects either % flow rate, actual flow rate or totalized value to be displayed in the main display.	<div style="border: 1px solid black; padding: 5px; text-align: right;"> 20.0 % * DISP SELECT % </div>
COM SELECT	Selects a communication method.	<div style="border: 1px solid black; padding: 5px; text-align: right;"> 20.0 % * COM SELECT SFN. A </div>
MODE ENTER ENGINEERING	Enters the ENGINEERING MODE.	<div style="border: 1px solid black; padding: 5px; text-align: right;"> 20.0 % * MODE ENTER ENGINEERING </div>
MODE ENTER MAINTENANCE	Enters the MAINTENANCE MODE.	<div style="border: 1px solid black; padding: 5px; text-align: right;"> 20.0 % * MODE ENTER MAINTENANCE </div>

LCD display flow

The LCD display flow of the OPERATOR'S MODE is as shown below:

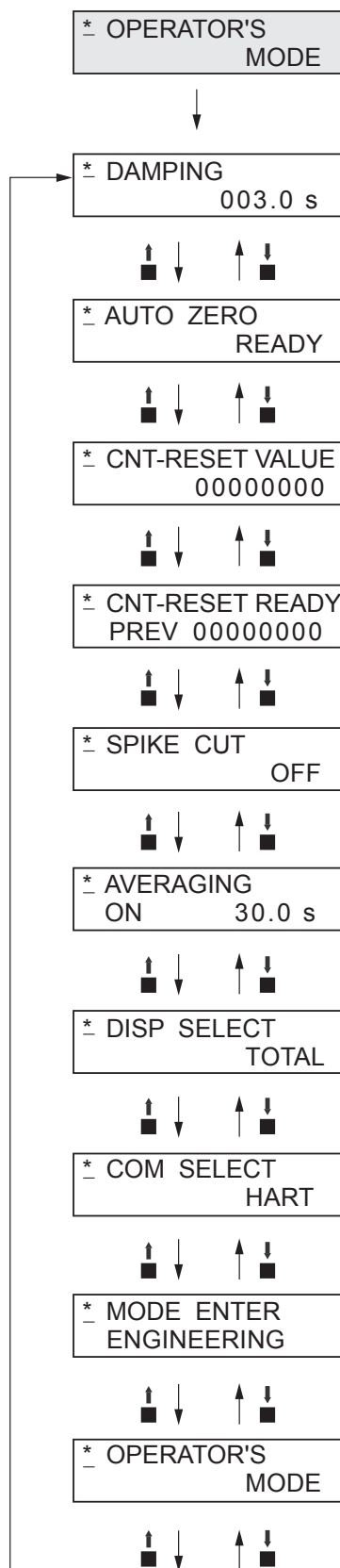

5-5-1 : Changing setting of damping time constant

Damping means a response time of the primary time lag (63.2% response) for a step response of the flow rate. If the out fluctuations are large, increase the damping. A large damping value stabilizes the output but lowers the response performance. We suggest setting the damping to the largest value the system can accept.

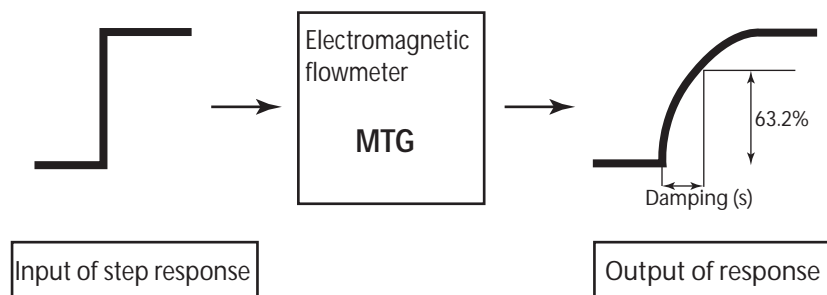

Figure 5-1 Damping output characteristics

Set the damping time constant in accordance with the following procedure:

Step	Procedure	Screen
1	The screen at right is a screen display example in MEASURING MODE (measurement state). Press the MODE key.	<pre> 20.0 % 01.94 m³/h WPO 00069401 </pre>
2	The OPERATOR'S MODE screen appears for approx. two seconds and then the damping setting screen appears.	<pre> 20.0 % * OPERATOR'S MODE * DAMPING 20.0 % * DAMPING 005.0 s </pre>
3	Press the → key until the cursor is at the value to be changed. In this example, the key is pressed three times to move to the position “5.”	<pre> * DAMPING 20.0 % * DAMPING 00<u>5</u>.0 s </pre>
4	Press the ↑ or ↓ key to display a time constant to be changed. In this example, the ↑ key is pressed five times to change the damping time from 5 seconds to 10 seconds.	<pre> * DAMPING 20.0 % * DAMPING 00<u>5</u>.0 s </pre>
5	Press the → key until the cursor is back at the mode indicator. Press the MODE key to return to the MEASURING MODE and to save data.	<pre> * DAMPING 20.0 % * DAMPING 005.0 s </pre>

⚠ CAUTION

You have only ten minutes to return to MEASURING MODE to save the new value before the system resets it to the previously saved value.

5-5-2 : Auto zero adjustment

Auto zero must be carried out only under the condition when the detector is filled with process fluid at zero flow. Run this function only after installing the electromagnetic flowmeter to the process pipe. Performing this function under a condition where the process fluid is not at zero flow may cause measurement errors.

Set range: None in particular

Default: None in particular

~Note *The zero adjustment takes approx. two minutes. During the zero adjustment, the output of analog current may rise to approx. 9 mA in some cases. This is not abnormal. To carry out the zero adjustment, set the control loop to manual.*

Make the auto zero adjustment in accordance with the following procedure:

Step	Procedure	Screen
1	The screen at right is a screen display example in MEASURING MODE (measurement state). Press the MODE key.	<div style="border: 1px solid black; padding: 5px; text-align: center;"> 1.0 % 01.94 m³/h 00069401 </div>
2	The OPERATOR'S MODE screen appears for approx. two seconds and then the damping setting screen appears.	<div style="border: 1px solid black; padding: 5px; text-align: center;"> 1.0 % * OPERATOR'S _ MODE </div> <div style="border: 1px solid black; padding: 5px; text-align: center;"> 1.0 % * DAMPING 005.0 s </div>
3	Press the ↑ key once to display the screen as shown.	<div style="border: 1px solid black; padding: 5px; text-align: center;"> 0.0 % * AUTO ZERO _ READY </div>
4	Press the → key to move the cursor to the position READY.	<div style="border: 1px solid black; padding: 5px; text-align: center;"> 0.0 % * AUTO ZERO _ READY </div>
5	Press the ↑ key to start the auto zero adjustment. If the main display selects % flowrate, the display of 0.0 blinks during adjustment. With the adjustment completed, the display stops blinking with ON switched to READY. This zero adjustment takes about two minutes.	<div style="border: 1px solid black; padding: 5px; text-align: center;"> 0.0 % * AUTO ZERO _ ON </div> <div style="border: 1px solid black; padding: 5px; text-align: center;"> 0.0 % * AUTO ZERO _ READY </div>
6	Press the → key to move the cursor to the position under *. Press the MODE key to return to the MEASURING MODE and save data.	<div style="border: 1px solid black; padding: 5px; text-align: center;"> 0.0 % * AUTO ZERO _ READY </div>

⚠ CAUTION

You have only ten minutes to return to MEASURING MODE to save the new value before the system resets it to the previously saved value.

5-5-3 : Setting of built-in counter reset value

Set a start value of the built-in counter. The scale of this value is considered as the weight of the pulse. Carry out the built-in counter reset in Section 5.4.5 to start totalization from any totalized value.

Set range: 00000000 - 99999999

Default: 00000000

Set an internal counter reset value in accordance with the following procedure:

Step	Procedure	Screen
1	The screen at the right is a screen display example in MEASURING MODE (measurement state). Press the MODE key.	<div style="border: 1px solid black; padding: 5px; width: fit-content;"> <div style="text-align: right;">20.0 %</div> <div style="text-align: right;">01.94 m³/h</div> <div style="text-align: left;">WPO</div> <div style="text-align: right;">00069401</div> </div>
2	The OPERATOR'S MODE screen appears for approx. two seconds and then the damping setting screen appears.	<div style="border: 1px solid black; padding: 5px; width: fit-content;"> <div style="text-align: right;">20.0 %</div> <div style="text-align: left;">* OPERATOR'S</div> <div style="text-align: right;">MODE</div> </div> <div style="border: 1px solid black; padding: 5px; width: fit-content;"> <div style="text-align: right;">20.0 %</div> <div style="text-align: left;">* DAMPING</div> <div style="text-align: right;">005.0 s</div> </div>
3	Press the ↑ key twice to display the screen.	<div style="border: 1px solid black; padding: 5px; width: fit-content;"> <div style="text-align: right;">20.0 %</div> <div style="text-align: left;">* CNT-RESET VALUE</div> <div style="text-align: right;">00044444</div> </div>
4	Press the → key to move the cursor to the position under a target value to be changed.	<div style="border: 1px solid black; padding: 5px; width: fit-content;"> <div style="text-align: right;">20.0 %</div> <div style="text-align: left;">* CNT-RESET VALUE</div> <div style="text-align: right;">0000<u>0</u>000</div> </div>
5	Press the ↑ or ↓ key to set a desired value.	<div style="border: 1px solid black; padding: 5px; width: fit-content;"> <div style="text-align: right;">20.0 %</div> <div style="text-align: left;">* CNT-RESET VALUE</div> <div style="text-align: right;">0000<u>5</u>000</div> </div>
6	Press the → key to move the cursor to the position under *. Press the MDOE key to return to the MEASURING MODE and to save data.	<div style="border: 1px solid black; padding: 5px; width: fit-content;"> <div style="text-align: right;">20.0 %</div> <div style="text-align: left;">* CNT-RESET VALUE</div> <div style="text-align: right;">00005000</div> </div>

⚠ CAUTION

You have only ten minutes to return to MEASURING MODE to save the new value before the system resets it to the previously saved value.

5-5-4 : Setting of built-in counter reset value

Reset the built-in counter to start totalization from a value set as the built-in counter reset value. If this value is set to 1000, the built-in counter starts totalization from 1000 after the counter is completely reset.

If the built-in counter is reset, the built-in counter value just before the reset appears at the side of PREV on the LCD display.

Set range: None

Default: None

Reset the internal counter in accordance with the following procedure:

Step	Procedure	Screen
1	The screen at the right is a screen display example in MEASURING MODE (measurement state). Press the MODE key.	<div style="border: 1px solid black; padding: 5px; width: fit-content;"> <p style="text-align: right;">20.0 % 01.94 m³/h</p> <p>WPO 00069401</p> </div>
2	The OPERATOR'S MODE screen appears for approx. two seconds and then the damping setting screen appears.	<div style="border: 1px solid black; padding: 5px; width: fit-content;"> <p style="text-align: right;">20.0 % * _ OPERATOR'S MODE</p> </div> <div style="border: 1px solid black; padding: 5px; width: fit-content;"> <p style="text-align: right;">20.0 % * _ DAMPING 005.0 s</p> </div>
3	Press the ↑ key three times to display the screen shown on the right.	<div style="border: 1px solid black; padding: 5px; width: fit-content;"> <p style="text-align: right;">20.0 % * _ CNT-RESET READY PREV 00000000</p> </div>
4	Press the → key to move the cursor to the position READY.	<div style="border: 1px solid black; padding: 5px; width: fit-content;"> <p style="text-align: right;">20.0 % * CNT-RESET <u>READY</u> PREV 00000000</p> </div>
5	Press the ↑ key to reset. In 0.5 seconds, the reset is completed with ON changing to READY.	<div style="border: 1px solid black; padding: 5px; width: fit-content;"> <p style="text-align: right;">20.0 % * CNT-RESET <u>ON</u> PREV 00000000</p> </div> <div style="border: 1px solid black; padding: 5px; width: fit-content;"> <p style="text-align: right;">20.0 % * CNT-RESET READY PREV 00123456</p> </div>
6	Press the → key to move the cursor to the position under *. Press the MODE key to return to the MEASURING MODE and save data.	<div style="border: 1px solid black; padding: 5px; width: fit-content;"> <p style="text-align: right;">20.0 % * _ CNT-RESET READY PREV 00123456</p> </div>

⚠ CAUTION

You have only ten minutes to return to MEASURING MODE to save the new value before the system resets it to the previously saved value.

5-5-5 : Setting auto spike cut

This function eliminates steep noise spikes (spike noise) in the flow rate. Noise generated when foreign matters collide with electrode is an example of the spike noise.

When the flow rate changes sharply, this function holds the outputs according to the damping time. Generally the spike noise occurs in a few milliseconds and settles down within the output holding time and the outputs are not affected. For ordinary flowrate changes, the output responds after the damping hold time.

It is not recommended to use this function for applications requiring high response and performance, e.g., the function should not be used when a pump frequently generates pulsation.

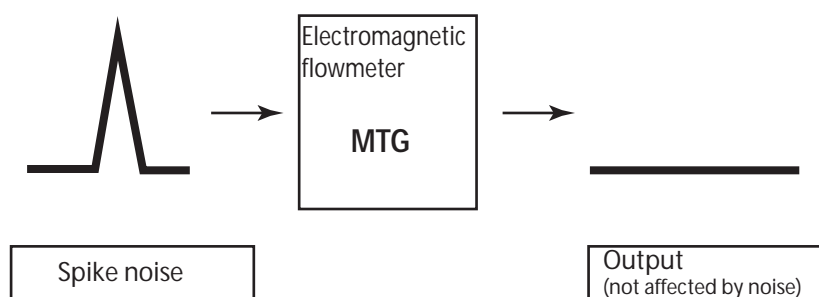

Figure 5-2 Auto spike cut output characteristics

Set the auto spike cut in accordance with the following procedure.

Step	Procedure	Screen
1	The screen at right is a screen display example in MEASURING MODE (measurement state). Press the MODE key.	<pre> 20.0 % 01.94 m³/h WPO 00069401 </pre>
2	The OPERATOR'S MODE screen appears for approx. two seconds and then the damping setting screen appears.	<pre> 20.0 % * OPERATOR'S MODE </pre> <pre> 20.0 % * DAMPING 005.0 s </pre>
3	Press the ↑ key four times to display the screen shown on the right.	<pre> 20.0 % * SPIKE CUT OFF </pre>
4	Press the → key to move the cursor to the OFF position.	<pre> 20.0 % * SPIKE CUT OFF </pre>

Step	Procedure	Screen
5	Press the ↑ or ↓ key to select ON or OFF.	<div style="border: 1px solid black; padding: 5px; width: fit-content;"> <div style="text-align: right;">20.0 %</div> * SPIKE CUT <div style="text-align: right;">ON</div> </div>
6	Press the → key to move the cursor to the position under *. Press the MODE key to return to the MEASURING MODE and save data.	<div style="border: 1px solid black; padding: 5px; width: fit-content;"> <div style="text-align: right;">20.0 %</div> * SPIKE CUT <div style="text-align: right;">OFF</div> </div>

⚠ CAUTION

You have only ten minutes to return to MEASURING MODE to save the new value before the system resets it to the previously saved value.

5-5-6 : Setting moving average processing

This function is used to carry out the moving average processing of the measured flow rate values. The model MTG performs the flow rate calculation every 400 ms. For example, if the moving average process time is set to 2 seconds, the moving average processing will be carried out 2 sec./400 ms = 5 times.

If pulsation are generated, this function can be used to suppress the flow rate fluctuations. The moving average processing can be given by the following formula:

$$Q_{current} = \frac{\sum_{n=1}^k Q_k}{k}$$

Example) When the moving average processing is set to 2 sec.:

$$Q_{current} = \frac{q_k + Q_{k-1} + Q_{k-2} + Q_{k-3} + Q_{k-4}}{5}$$

where q_k is a value currently measured, and Q_k is a previous output value.

Set range: ON / OFF
 ON (1.0 to 30.0 s)
 Default: OFF

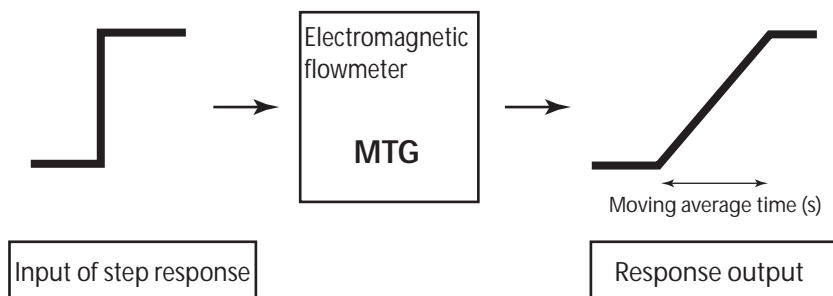

Figure 5-3 Output characteristics of moving average processing

Set the moving average processing in accordance with the following procedure:

Step	Procedure	Screen
1	The screen at right is a screen display example in MEASURING MODE (measurement state). Press the MODE key.	<div style="border: 1px solid black; padding: 5px; width: fit-content;"> <p style="text-align: right;">20.0 %</p> <p style="text-align: right;">01.94 m³/h</p> <p>WPO 00069401</p> </div>
2	The OPERATOR'S MODE screen appears for approx. two seconds and then the damping setting screen appears.	<div style="border: 1px solid black; padding: 5px; width: fit-content;"> <p style="text-align: right;">20.0 %</p> <p>* _ OPERATOR'S MODE</p> </div> <div style="border: 1px solid black; padding: 5px; width: fit-content;"> <p style="text-align: right;">20.0 %</p> <p>* _ DAMPING</p> <p style="text-align: right;">005.0 s</p> </div>
3	Press the ↑ or ↓ key to display the screen shown on the right.	<div style="border: 1px solid black; padding: 5px; width: fit-content;"> <p style="text-align: right;">20.0 %</p> <p>* _ AVERAGING</p> <p>OFF</p> </div>
4	Press the → key to move the cursor to the OFF position.	<div style="border: 1px solid black; padding: 5px; width: fit-content;"> <p style="text-align: right;">20.0 %</p> <p>* AVERAGING</p> <p>OFF</p> </div>
5	Press the ↑ key to switch the OFF screen to the ON screen. Press the → key to move the cursor to the value to be changed.	<div style="border: 1px solid black; padding: 5px; width: fit-content;"> <p style="text-align: right;">20.0 %</p> <p>* AVERAGING</p> <p>ON 01.0 s</p> </div>
6	Press the ↑ or ↓ key to display a value to be set.	<div style="border: 1px solid black; padding: 5px; width: fit-content;"> <p style="text-align: right;">20.0 %</p> <p>* AVERAGING</p> <p>ON 05.0 s</p> </div>
7	Press the → key to move the cursor back to the position under *. Press the MODE key to return to the MEASURING MODE and save data.	<div style="border: 1px solid black; padding: 5px; width: fit-content;"> <p style="text-align: right;">20.0 %</p> <p>* _ AVERAGING</p> <p>ON 05.0 s</p> </div>

⚠ CAUTION

You have only ten minutes to return to MEASURING MODE to save the new value before the system resets it to the previously saved value.

5-5-7 : Setting empty pipe detection

Overview of empty pipe detection

The empty pipe detection function fixes analog output (4 to 20 mA) and pulse output to zero flow values when the detector is empty.

The display alternately shows zero value and “Empty Status”.

Mechanism of empty pipe detection

Detect empty pipe condition by monitoring flow rate signal. Once the flow rate signal fluctuates over a certain threshold, the device judges that the detector is empty.

There are three threshold levels to meet an environment where the device is installed.

Set an appropriate threshold level from below.

SENSITIVITY HIGH

SENSITIVITY MID

SENSITIVITY LOW

Outputs

Analog output (4 to 20 mA): Fixes to 0% (4 mA)

Pulse output: Fixes to 0 (does not generate pulses)

Display: Flashes the messages "0%" and "EMPTY STATUS" alternately (when % flow rate is specified for the main display)

Flashes the messages "0.000 RATE" and "EMPTY STATUS" alternately (when actual flow rate is specified for the main display)

Flashes the messages "XXXXXXXX" (totalized value at setup) and "EMPTY STATUS" alternately (when totalized value is specified for the main display)

Operation conditions

- The grounding work must be securely carried out (grounding resistance 100Ω or less).
- The fluid conductivity must be 30 μS/cm or greater.
- The noise level must be higher than or equal to the set threshold value when the pipe is empty.
- The noise level must be lower than or equal to the set threshold value when the pipe is filled with fluid.

Default

SENSITIVITY OFF

Setting parameters

Table 5-1 Set levels for empty pipe detection

Empty pipe detection sensitivity	Noise detection level
SENSITIVITY OFF	Empty pipe detection function OFF
SENSITIVITY HIGH	Signal level Threshold LOW
SENSITIVITY MID	Signal level Threshold MID
SENSITIVITY LOW	Signal level Threshold HIGH

~Note 1 *This function is only available for detectors with a bore diameter of 10 mm or more. When the diameter is 2.5 mm or 5 mm, the setting screen for this function appears in the converter's display, but is not applicable.*

~Note 2 *This function is applicable for the converters with ROM version 3.8 or higher. If it is 3.7 or lower, the setting screen for this function is not displayed. To check the ROM version, refer to 5.7.7 "Displaying ROM version and date".
To use the empty pipe detection function with the ROM version 3.7 or lower, the main board must be replaced. For details, contact our sales representative.*

Set the empty pipe detection function in accordance with the following procedure.

Step	Procedure	Screen
1	The screen at right is a screen display example in MEASURING MODE (measurement state).	<div style="border: 1px solid black; padding: 5px; width: fit-content;"> <p style="text-align: right;">20.0 %</p> <p style="text-align: right;">01.94 m³/h</p> <p>WPO 00069401</p> </div>
2	Press the MODE key. The OPERATOR'S MODE screen appears for approx. two seconds, and then the damping setting screen appears.	<div style="border: 1px solid black; padding: 5px; width: fit-content;"> <p style="text-align: right;">20.0 %</p> <p>* OPERATOR'S MODE</p> </div> <div style="border: 1px solid black; padding: 5px; width: fit-content; margin-top: 5px;"> <p style="text-align: right;">20.0 %</p> <p>* DAMPING</p> <p style="text-align: right;">005.0 s</p> </div>
3	Press the ↑ key to display the screen shown on the right.	<div style="border: 1px solid black; padding: 5px; width: fit-content;"> <p style="text-align: right;">20.0 %</p> <p>* EMPTY SENSITIVITY OFF</p> </div>
4	Press the → key to move the cursor to the OFF position.	<div style="border: 1px solid black; padding: 5px; width: fit-content;"> <p style="text-align: right;">20.0 %</p> <p>* EMPTY SENSITIVITY <u>OFF</u></p> </div>
5	Press the ↑ key to select SENSITIVITY HIGH.	<div style="border: 1px solid black; padding: 5px; width: fit-content;"> <p style="text-align: right;">20.0 %</p> <p>* EMPTY SENSITIVITY <u>HIGH</u></p> </div>
6	Press the → key to move the cursor to the position under *. Press the MODE key to return to the MEASURING MODE, and save the data.	<div style="border: 1px solid black; padding: 5px; width: fit-content;"> <p style="text-align: right;">20.0 %</p> <p>* EMPTY SENSITIVITY HIGH</p> </div>
7	<p>Empty the pipe with SENSITIVITY HIGH set to check if the function detects the empty status. Perform the checking when 30 seconds or more have passed, because it takes at least 30 seconds to detect the empty status after the pipe becomes empty.</p> <p>(Result) When the empty status is detected, the screen at right appears. The "EMPTY STATUS" message is flashing, the analog output is fixed to 4 mA, and the pulse output stops.</p>	<div style="border: 1px solid black; padding: 5px; width: fit-content; margin-top: 20px;"> <p style="text-align: right;">0.0 %</p> <p>EMPTY</p> <p style="text-align: right;">STATUS</p> </div>

(To the next page)

Step	Procedure	Screen																				
8	<p>Repeat steps 1 to 5 to set SENSITIVITY MID or SENSITIVITY LOW to check if the function also detects the empty status with the converter's display.</p> <p>Depending on whether the empty status is detected in each setting, the result falls into one of the following.</p> <p>(Results of empty pipe detection operation check in empty status)</p> <table border="1"> <thead> <tr> <th>Setting</th> <th>Results (1)</th> <th>Results (2)</th> <th>Results (3)</th> <th>Results (4)</th> </tr> </thead> <tbody> <tr> <td>LOW</td> <td>EMPTY STATUS flashes</td> <td>EMPTY STATUS does not flash</td> <td>EMPTY STATUS does not flash</td> <td>EMPTY STATUS does not flash</td> </tr> <tr> <td>MID</td> <td>EMPTY STATUS flashes</td> <td>EMPTY STATUS flashes</td> <td>EMPTY STATUS does not flash</td> <td>EMPTY STATUS does not flash</td> </tr> <tr> <td>HIGH</td> <td>EMPTY STATUS flashes</td> <td>EMPTY STATUS flashes</td> <td>EMPTY STATUS flashes</td> <td>EMPTY STATUS does not flash</td> </tr> </tbody> </table> <ul style="list-style-type: none"> If the empty status is not detected when HIGH has been set (in the case of result (4)), this function is not available in that installation environment. <p>Repeat steps 1 to 5 to set the function to OFF.</p>	Setting	Results (1)	Results (2)	Results (3)	Results (4)	LOW	EMPTY STATUS flashes	EMPTY STATUS does not flash	EMPTY STATUS does not flash	EMPTY STATUS does not flash	MID	EMPTY STATUS flashes	EMPTY STATUS flashes	EMPTY STATUS does not flash	EMPTY STATUS does not flash	HIGH	EMPTY STATUS flashes	EMPTY STATUS flashes	EMPTY STATUS flashes	EMPTY STATUS does not flash	
Setting	Results (1)	Results (2)	Results (3)	Results (4)																		
LOW	EMPTY STATUS flashes	EMPTY STATUS does not flash	EMPTY STATUS does not flash	EMPTY STATUS does not flash																		
MID	EMPTY STATUS flashes	EMPTY STATUS flashes	EMPTY STATUS does not flash	EMPTY STATUS does not flash																		
HIGH	EMPTY STATUS flashes	EMPTY STATUS flashes	EMPTY STATUS flashes	EMPTY STATUS does not flash																		
9	<p>Next, fill fluid into the pipe.</p> <p>Check that the empty status is not detected in this condition.</p> <p>Since it takes at least 30 seconds to clear the empty status after fluid is filled in the pipe, perform checking when 30 seconds or more have passed after fluid is filled.</p> <p>(Branch 1)</p> <ul style="list-style-type: none"> When the result is (1) in step 8 Check that the empty status is not detected when SENSITIVITY LOW has been set. <p>(Result)</p> <ul style="list-style-type: none"> If the empty status is not detected, use that SENSITIVITY LOW setting without change. If the empty status is detected and the screen shown on the right appears, this function is not available in that environment. Set the function to OFF. 	<table border="1"> <tr> <td>EMPTY</td> <td>0.0 %</td> </tr> <tr> <td>STATUS</td> <td></td> </tr> </table>	EMPTY	0.0 %	STATUS																	
EMPTY	0.0 %																					
STATUS																						

(To the next page)

Step	Procedure	Screen
<p>9 (Continued)</p>	<p>(Branch 2)</p> <ul style="list-style-type: none"> When the result is (2) in step 8 Check that the empty status is not detected when SENSITIVITY MID has been set. <p>(Result)</p> <ul style="list-style-type: none"> If the empty status is not detected, use that SENSITIVITY MID setting without change. If the empty status is detected and the screen shown on the right appears, this function is not available in that environment. Set the function to OFF. <p>(Branch 3)</p> <ul style="list-style-type: none"> When the result is (3) in step 8 Check that the empty status is not detected when SENSITIVITY HIGH has been set. <p>(Result)</p> <ul style="list-style-type: none"> If the empty status is not detected, use that SENSITIVITY HIGH setting without change. If the empty status is detected and the screen shown on the right appears, this function is not available in that environment. Set the function to OFF. 	<div data-bbox="1067 602 1358 707" style="border: 1px solid black; padding: 5px; margin-bottom: 20px;"> <p style="text-align: right;">0.0 %</p> <p>EMPTY STATUS</p> </div> <div data-bbox="1067 1102 1358 1207" style="border: 1px solid black; padding: 5px;"> <p style="text-align: right;">0.0 %</p> <p>EMPTY STATUS</p> </div>

Empty pipe detection flow chart

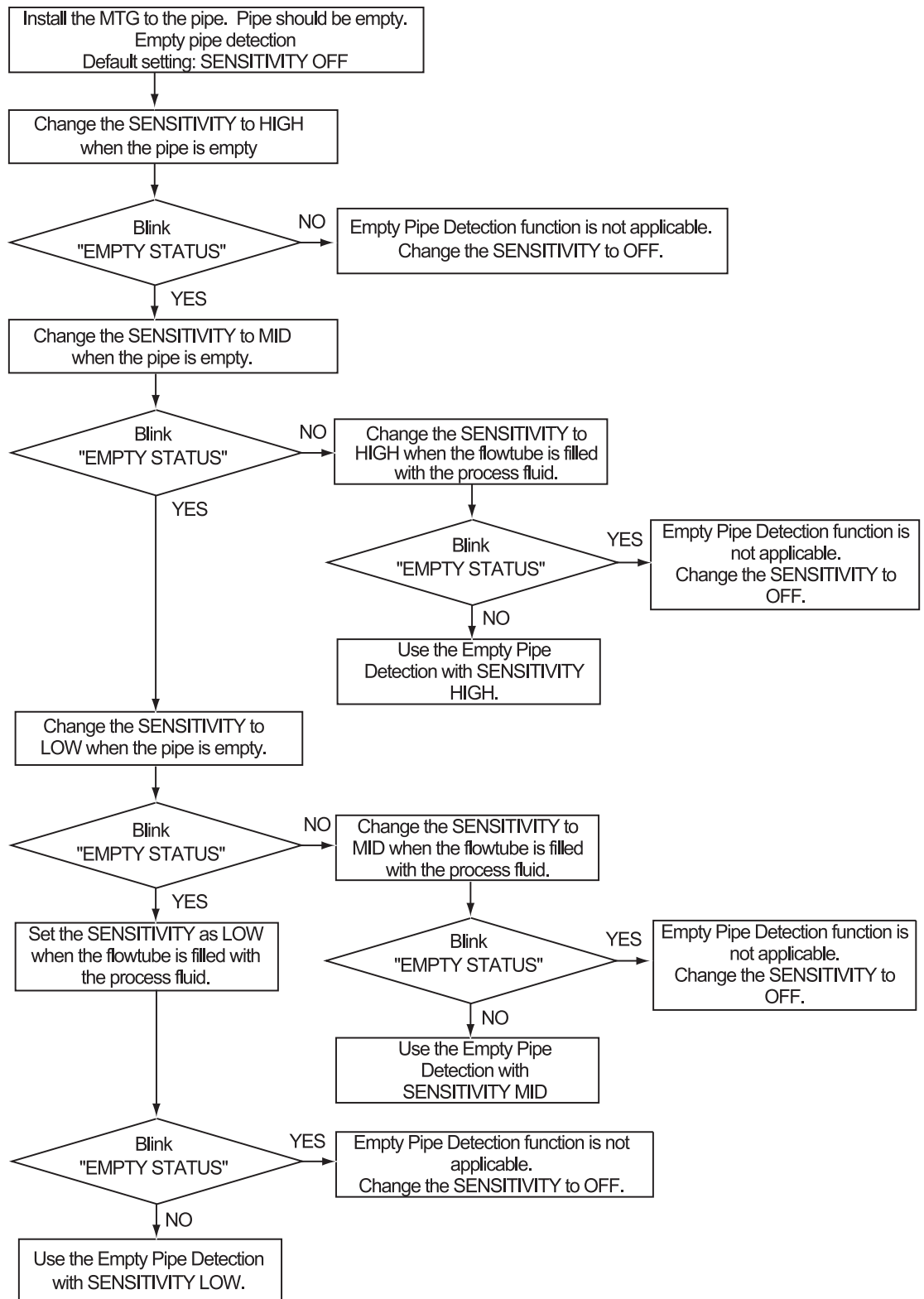

Empty pipe detection troubleshooting

Troubleshooting

If a problem occurs during empty pipe detection, take appropriate actions in accordance with the following procedure.

Trouble	Check point and troubleshooting
<ul style="list-style-type: none"> Empty pipe detection mistake when fluid is filled because the unit is used in the place where the flow rate changes swiftly. 	<p>When the flow rate swiftly changes due to pulsations from the pump, the function may recognize some of the swinging flow rate signals as those in the empty status and mistakenly determine it as empty. In this case, it is recommended to install the unit in the place where no effects from the pulsation can be reached, e.g., by securing a longer upstream straight pipe section. When the unit is installed in a place where swift change of the flow rate may cause misdetection of the empty status when fluid is filled, set this function to OFF. Please note that increasing the damping time constant does not solve this problem because this function determines the empty status based on the signals before the damping process.</p>
<ul style="list-style-type: none"> Empty not detected when the pipe is empty. 	<p>If there is conductivity between electrodes or between the electrode and grounding ring due to the fluid left in the pipe, etc., the empty status may not be detected even when the pipe is empty. In this case, this function is not available. Set it to OFF.</p> <p>If the display and output are not always fixed to zero because, for example, the fluid drops on the electrode, they may become stable at zero by increasing the setting value for low flow cutoff and setting the auto spike cut to ON.</p>
<ul style="list-style-type: none"> Empty pipe detection operation error after the surrounding noise environment has been changed by expansion of equipment etc., such as changing the installation location or installing the high-current motors or pumps. 	<p>Since change of the environment also changes the noise volume, the empty pipe detection may not function correctly with the conventional threshold value for it. In this case, reset the threshold value.</p>
<ul style="list-style-type: none"> Empty detected with flowing fluid in fluid-filled status (empty not detected with stationary fluid). 	<p>The empty status may be detected even when the fluid is filled because of the effects of the flow noises generated from the flowing fluid. In this case, reset the threshold value so that the empty status is not mistakenly detected when the fluid is flowing.</p>

5-5-8 : Selecting flow rate to be displayed in the main display

Select the flow rate to be always shown in the main display. The flow rates other than that selected for the main display are shown in the sub displays. Thereby, three flow rates can always be monitored.

Set	Description
%	% flow rate
RATE	Actual flow rate
TOTAL	Totalized value

% (% flow rate): Displays % flow rate

RATE (Actual flow rate)

Setting range: %, RATE, TOTAL

Default: RATE

Select the flow rate to be shown in the main display in accordance with the following procedure:

Step	Procedure	Screen
1	The screen at right is a screen display example in MEASURING MODE (measurement state). Press the MODE key.	<div style="border: 1px solid black; padding: 5px; text-align: right;"> 20.0 % 01.94 m³/h WPO 00069401 </div>
2	The OPERATOR'S MODE screen appears for approx. two seconds and then the damping setting screen appears.	<div style="border: 1px solid black; padding: 5px; text-align: right;"> 20.0 % * OPERATOR'S _ MODE </div> <div style="border: 1px solid black; padding: 5px; text-align: right;"> 20.0 % * DAMPING 005.0 s </div>
3	Press the ↑ or ↓ key to display the screen as shown on the right.	<div style="border: 1px solid black; padding: 5px; text-align: right;"> 20.0 % * DISP SELECT _ % </div>
4	Press the → key to move the cursor to the position for the flow rate display method (% , RATE, TOTAL). The screen at right shows an example where % flow rate has been set for the main display.	<div style="border: 1px solid black; padding: 5px; text-align: right;"> 20.0 % * OPERATOR'S _ MODE </div>
5	Press the ↑ or ↓ key to select a flow rate display to be set. The screen at right shows an example where RATE (actual flow rate) display has been selected.	<div style="border: 1px solid black; padding: 5px; text-align: right;"> 0.30 RATE * DISP SELECT _ RATE </div>
6	Press the → key to move the cursor to the position under *. Press the MODE key to return to the MEASURING MODE and to change to the set flow rate display.	<div style="border: 1px solid black; padding: 5px; text-align: right;"> 0.30 RATE * DISP SELECT _ RATE </div>

CAUTION

You have only ten minutes to return to MEASURING MODE to save the new value before the system resets it to the previously saved value.

5-5-9 : Selecting a communication system

Select the communication system (SFC, DE, HART, and communication disable).

Select a communication system to be used. Note that the converter will be rebooted when the MODE key is pressed to switch to the MEASURING MODE after the settings are changed.

HART: HART communication by using the HART Communicator.

SFN.A: SFC in the analog (4-20 mA) output mode.

SFN.D: DE (Digital Enhanced) communication.

NONE: Communication is not used/disable.

By default, SFN.A: SFC communication is set.

Select a communication system in accordance with the following procedure:

Step	Procedure	Screen
1	The screen at right is a screen display example in MEASURING MODE (measurement state). Press the MODE key.	<div style="border: 1px solid black; padding: 5px; width: fit-content;"> <div style="text-align: right;">20.0 %</div> <div style="text-align: right;">01.94 m³/h</div> <div style="text-align: left;">WPO</div> <div style="text-align: right;">00069401</div> </div>
2	The OPERATOR'S MODE screen appears for approx. two seconds and then the damping setting screen appears.	<div style="border: 1px solid black; padding: 5px; width: fit-content;"> <div style="text-align: right;">20.0 %</div> <div style="text-align: left;">* OPERATOR'S</div> <div style="text-align: right;">MODE</div> </div> <div style="border: 1px solid black; padding: 5px; width: fit-content;"> <div style="text-align: right;">20.0 %</div> <div style="text-align: left;">* DAMPING</div> <div style="text-align: right;">005.0 s</div> </div>
3	Press the ↑ key three times to display the screen as shown on the right.	<div style="border: 1px solid black; padding: 5px; width: fit-content;"> <div style="text-align: right;">20.0 %</div> <div style="text-align: left;">* COM SELECT</div> <div style="text-align: right;">SFN. A</div> </div>
4	Press the → key to move the cursor to the position for the communication system (SFN.A, SFN.D, NONE, HART). The screen at right shows an example where SFN.A has been selected for the communication system.	<div style="border: 1px solid black; padding: 5px; width: fit-content;"> <div style="text-align: right;">20.0 %</div> <div style="text-align: left;">* COM SELECT</div> <div style="text-align: right;">SFN. A</div> </div>
5	Press the ↑ or ↓ key to select a desired communication system to be set. The screen at right shows an example where HART communication has been selected.	<div style="border: 1px solid black; padding: 5px; width: fit-content;"> <div style="text-align: right;">20.0 %</div> <div style="text-align: left;">* COM SELECT</div> <div style="text-align: right;">HART</div> </div>

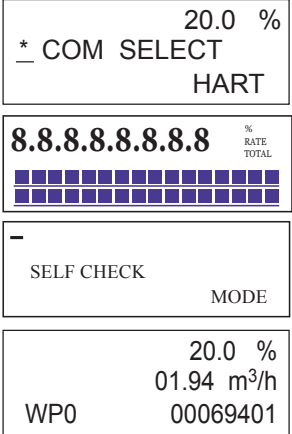
Step	Procedure	Screen
6	Press the → key to move the cursor to the position under *. Pressing the MODE key reboots the converter, returns to MEASURING MODE, and the communication system changes and saved.	

⚠ CAUTION

You have only ten minutes to return to MEASURING MODE to save the new value before the system resets it to the previously saved value.

5-5-10 : Entering ENGINEERING MODE and MAINTENANCE MODE

Introduction

This section describes how to enter ENGINEERING MODE, in which setup parameters for the electromagnetic flowmeter are to be configured, and MAINTENANCE MODE, in which calibration and check are to be carried out.

~Note *The mode selection screen may not appear, depending on the settings of write protect. Operate the write protect switch on the main board, and then select one from levels 1, 2 and 3 to display the screen for selecting ENGINEERING MODE only. Select write protect level 0 to display the screen for selecting both ENGINEERING MODE and MAINTENANCE MODE. See “5-3-2 : Display of write protect level”.*

The procedure for entering ENGINEERING MODE is shown below.

Step	Procedure	Screen
1	The screen shown right is a screen display example in MEASURING MODE (measurement state). Press the MODE key.	<div style="border: 1px solid black; padding: 5px; width: fit-content;"> <div style="text-align: right;">20.0 %</div> <div style="text-align: right;">01.94 m³/h</div> <div style="display: flex; justify-content: space-between;"> WP0 00069401 </div> </div>
2	The OPERATOR'S MODE screen appears for approx. two seconds and then the damping setting screen appears.	<div style="border: 1px solid black; padding: 5px; width: fit-content;"> <div style="text-align: right;">20.0 %</div> <div style="text-align: center;">* OPERATOR'S _ MODE</div> </div> <div style="border: 1px solid black; padding: 5px; width: fit-content;"> <div style="text-align: right;">20.0 %</div> <div style="text-align: center;">* DAMPING _ 005.0 s</div> </div>
3	Press the ↑ key twice to display the screen as shown.	<div style="border: 1px solid black; padding: 5px; width: fit-content;"> <div style="text-align: right;">20.0 %</div> <div style="text-align: center;">* MODE ENTER _ ENGINEERING</div> </div>
4	Press the → key once to move the cursor to the position shown on the screen.	<div style="border: 1px solid black; padding: 5px; width: fit-content;"> <div style="text-align: right;">20.0 %</div> <div style="text-align: center;">* MODE ENTER _ ENGINEERING</div> </div>
5	Press the ↑ key. With the display is changed, ENGINEERING MODE is active. The screen appears in approx. two seconds.	<div style="border: 1px solid black; padding: 5px; width: fit-content;"> <div style="text-align: right;">20.0 %</div> <div style="text-align: center;"># ENGINEERING _ MODE</div> </div> <div style="border: 1px solid black; padding: 5px; width: fit-content;"> <div style="text-align: right;">20.0 %</div> <div style="text-align: center;"># ID SET _ XXXXXXXX</div> </div>

The procedure for entering MAINTENANCE MODE is shown below.

Step	Procedure	Screen
1	The screen shown on the right is a screen display example in MEASURING MODE (measurement state). Press the MODE key.	<div style="border: 1px solid black; padding: 5px; width: fit-content;"> <div style="text-align: right;">20.0 %</div> <div style="text-align: right;">01.94 m³/h</div> <div>WP0 00069401</div> </div>
2	The OPERATOR'S MODE screen appears for approx. two seconds and then the damping setting screen appears.	<div style="border: 1px solid black; padding: 5px; width: fit-content;"> <div style="text-align: right;">20.0 %</div> <div>* OPERATOR'S</div> <div style="text-align: right;">MODE</div> </div> <div style="border: 1px solid black; padding: 5px; width: fit-content;"> <div style="text-align: right;">20.0 %</div> <div>* DAMPING</div> <div style="text-align: right;">005.0 s</div> </div>
3	Press the ↑ key once to display the screen as shown on the right.	<div style="border: 1px solid black; padding: 5px; width: fit-content;"> <div style="text-align: right;">20.0 %</div> <div>* MODE ENTER</div> <div style="text-align: right;">MAINTENANCE</div> </div>
4	Press the → key once to move the cursor to the position shown on the screen.	<div style="border: 1px solid black; padding: 5px; width: fit-content;"> <div style="text-align: right;">20.0 %</div> <div>* MODE ENTER</div> <div style="text-align: right;">MAINTENANCE</div> </div>
5	Press the ↑ key. With the display changed, MAINTENANCE MODE is active. The screen appears in approx. two seconds.	<div style="border: 1px solid black; padding: 5px; width: fit-content;"> <div style="text-align: right;">20.0 %</div> <div>≥ MAINTENANCE</div> <div style="text-align: right;">MODE</div> </div> <div style="border: 1px solid black; padding: 5px; width: fit-content;"> <div style="text-align: right;">20.0 %</div> <div>≥ OUTPUT CHECK</div> <div style="text-align: right;">MODE OFF</div> </div>

5-6 : Configuration of ENGINEERING MODE

Introduction

ENGINEERING MODE has the following setting and adjustment items:

For details on items, see “5-6-1 : Setting ID” to “5-6-14 : Setting contact output status”.

Item	Contents	Screen
ID SET	Sets ID and TAG No.	<div style="border: 1px solid black; padding: 5px; width: fit-content;"> <div style="text-align: right;">20.0 %</div> <div># ID SET XXXXXXXXXX</div> </div>
FUNC SET	Setting of open collector output, selects pulse output or contact output.	<div style="border: 1px solid black; padding: 5px; width: fit-content;"> <div style="text-align: right;">20.0 %</div> <div># FUNC SET PULSE</div> </div>
EX, TYPE, DIA	Sets the detector information (Ex value, detector type, and bore diameter).	<div style="border: 1px solid black; padding: 5px; width: fit-content;"> <div style="text-align: right;">20.0 %</div> <div># EX 300.0 MTG DIA 200</div> </div>
SPAN	Sets the flow rate range.	<div style="border: 1px solid black; padding: 5px; width: fit-content;"> <div style="text-align: right;">20.0 %</div> <div># 1.0000 m/s SPAN 7.0690 m³/h</div> </div>
GRAVITY	Sets the specific gravity when mass flow rate unit is selected.	<div style="border: 1px solid black; padding: 5px; width: fit-content;"> <div style="text-align: right;">20.0 %</div> <div># GRAVITY 1.0000</div> </div>
COEFFICIENT	Sets a compensation coefficient for flow rate calculation.	<div style="border: 1px solid black; padding: 5px; width: fit-content;"> <div style="text-align: right;">20.0 %</div> <div># COEFFICIENT 1.0000</div> </div>
PLS SCL	Sets flow rate (pulse scale) per pulse.	<div style="border: 1px solid black; padding: 5px; width: fit-content;"> <div style="text-align: right;">20.0 %</div> <div># PLS 10.000 Hz SCL 200.00 I/P</div> </div>
PLS WID	Sets the output pulse width.	<div style="border: 1px solid black; padding: 5px; width: fit-content;"> <div style="text-align: right;">20.0 %</div> <div># PLS 10.000 Hz WID 0010 ms</div> </div>

Item	Contents	Screen
DROP OUT	Sets drop out.	<div style="border: 1px solid black; padding: 5px; width: fit-content;"> <div style="text-align: right;">20.0 %</div> # DROPOUT <div style="text-align: right;">10 %</div> </div>
LOW FLOW CUT	Sets low flow cut.	<div style="border: 1px solid black; padding: 5px; width: fit-content;"> <div style="text-align: right;">20.0 %</div> # LOW FLOW CUT <div style="text-align: right;">10 %</div> </div>
HI-ALM/LOW-ALM	Sets upper/lower limit alarm.	<div style="border: 1px solid black; padding: 5px; width: fit-content;"> <div style="text-align: right;">20.0 %</div> # HI-AIM 100 % LO-AIM 0 % </div>
ERROR OUT MODE I. OUT	Determines the analog output failsafe direction.	<div style="border: 1px solid black; padding: 5px; width: fit-content;"> <div style="text-align: right;">20.0 %</div> # ERROR OUT MODE I.OUT HOLD </div>
ERROR OUT MODE P. OUT	Determines the pulse output failsafe direction.	<div style="border: 1px solid black; padding: 5px; width: fit-content;"> <div style="text-align: right;">20.0 %</div> # ERROR OUT MODE P.OUT HOLD </div>
ST. OUT MODE	Sets a contact output status.	<div style="border: 1px solid black; padding: 5px; width: fit-content;"> <div style="text-align: right;">20.0 %</div> # ST. OUTMODE NORMAL CLOSE </div>

~Note *After the MODE key is pressed, configured data in the ENGINEERING MODE are saved in non-volatile memory. When configure data, be sure to press the MODE key to save the data.*

LCD display flow

The ENGINEERING MODE display flow is as follows:

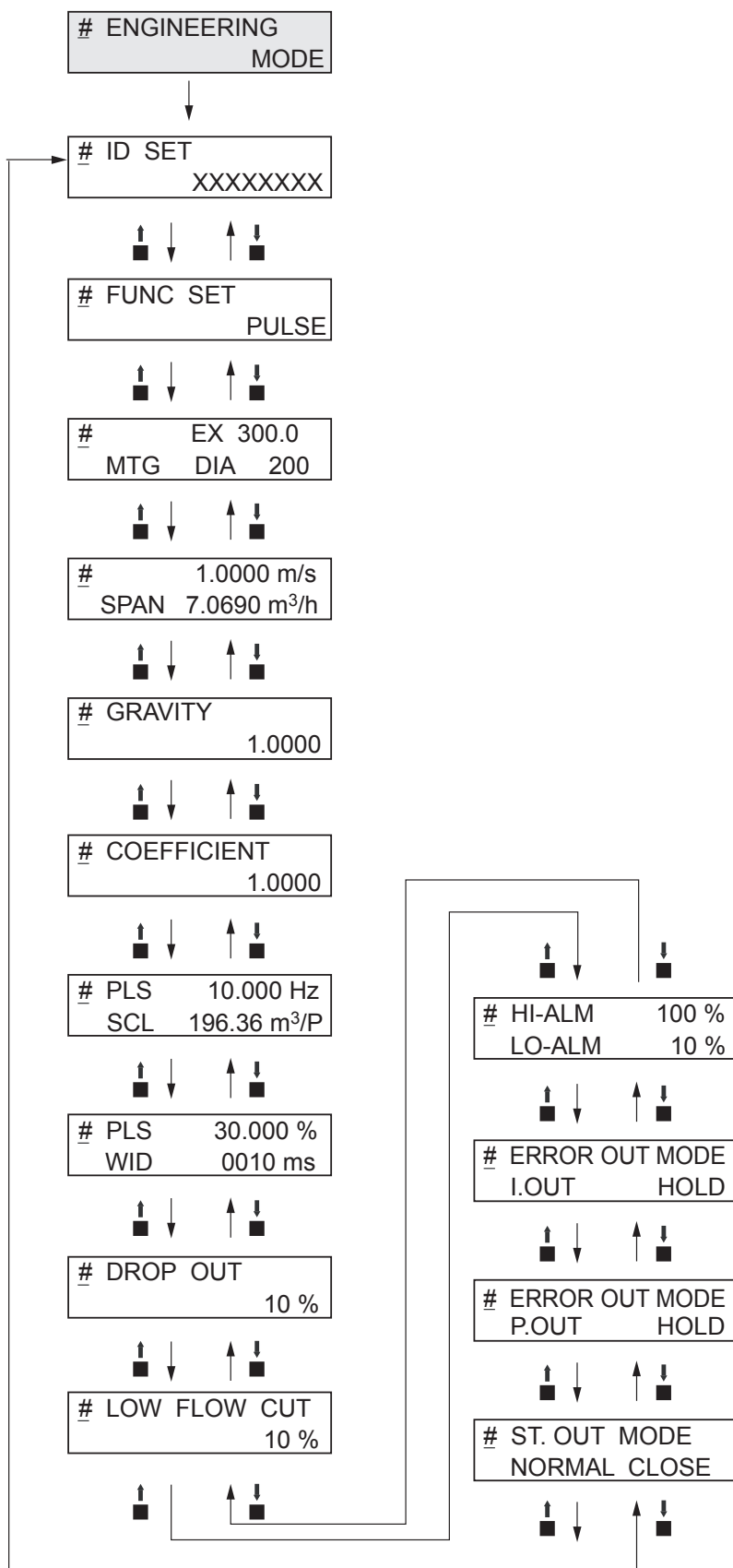

5-6-1 : Setting ID

You can enter a unique 8-digit alphanumeric code for the flowmeter.

Up to eight alphanumeric characters using any combination of letters (A to Z), numbers (0 to 9), - (dash), / (slash), space and period.

Set an ID in accordance with the following procedure:

Step	Procedure	Screen
1	Enter ENGINEERING MODE (see section 5-5-9 on page 5-30) and display the screen where the ID is to be set.	<div style="border: 1px solid black; padding: 5px; width: fit-content;"> <div style="text-align: right;">12.3 %</div> <div># ID SET</div> <div style="text-align: right;">XXXXXXXX</div> </div>
2	Press the → key to move the cursor to the position under a desired character to be changed.	<div style="border: 1px solid black; padding: 5px; width: fit-content;"> <div style="text-align: right;">12.3 %</div> <div># ID SET</div> <div style="text-align: right;">XXXXXXXX</div> </div>
3	Press the ↑ or ↓ key to select a desired character.	<div style="border: 1px solid black; padding: 5px; width: fit-content;"> <div style="text-align: right;">12.3 %</div> <div># ID SET</div> <div style="text-align: right;">FXXXXXXXX</div> </div>
4	If a target TAG NO. has been set, press the → key to move the cursor to the position under #. Press the MODE key to return to MEASURING MODE and to save data.	<div style="border: 1px solid black; padding: 5px; width: fit-content;"> <div style="text-align: right;">12.3 %</div> <div># ID SET</div> <div style="text-align: right;">FIC-0001</div> </div>

5-6-2 : Selecting pulse output or contact output

Pulse output or contact output are selectable. Both of them are open collector outputs.

When pulse output has been selected:

Set pulse scale, pulse width, drop out, and burn out.

When contact output has been selected:

As a contact output, self diagnosis output (critical failure) or upper/lower limit alarm is output.

Select % flow rate value for upper/lower alarm or output status (OPEN or CLOSE in normal (normal state)).

Setting range: PULSE: Selection of pulse output

STOUT: Selection of contact output

Default: PULSE

Select pulse output or contact output in accordance with the following procedure:

Step	Procedure	Screen
1	Enter ENGINEERING MODE in accordance with the entry into ENGINEERING MODE (see section 5-5-9 on page 5-30). Then press the ↑ or ↓ key to display the screen at right.	<div style="border: 1px solid black; padding: 5px; width: fit-content;"> <div style="text-align: right;">20.0 %</div> # FUNCSET <div style="text-align: right;">PULSE</div> </div>
2	Press the → key to move the cursor to the position for set function. Press the ↑ or ↓ key to display a function to be set. Select either PULSE (pulse output) or STOUT (contact output).	<div style="border: 1px solid black; padding: 5px; width: fit-content;"> <div style="text-align: right;">20.0 %</div> # FUNCSET <div style="text-align: right;"><u>P</u>LSE</div> </div> <div style="border: 1px solid black; padding: 5px; width: fit-content;"> <div style="text-align: right;">20.0 %</div> # FUNCSET <div style="text-align: right;"><u>S</u>TOUT</div> </div>
3	Press the MODE key to return to the MEASURING MODE and to save data.	<div style="border: 1px solid black; padding: 5px; width: fit-content;"> <div style="text-align: right;">20.0 %</div> # FUNCSET <div style="text-align: right;">STOUT</div> </div>

⚠ CAUTION

You have only ten minutes to return to MEASURING MODE to save the new value before the system resets it to the previously saved value.

5-6-3 : Setting detector information

Set detector information necessary for combination with the converter.

- EX value:** Each detector has a unique calibration factor (EX value). This value is determined at shipment in accordance with the actual flow rate calibration. DO NOT change this value or the flowmeter output will be incorrect.
- Detector type:** When measuring the flow rate, select MTG for the detector type. To perform adjustments and loop checks, select TST for the detector type.
- Bore diameter:** Sets the bore diameter (inside diameter) of the detector. The correct bore diameter is set as factory default setting.
- Setting range:** Detector constant: 200.0 to 699.9
Detector type: MTG/TST
Bore diameter: 2.5 to 200

Set the detector information in accordance with the following procedure:

Step	Procedure	Screen									
1	Enter ENGINEERING MODE in accordance with the entry into ENGINEERING MODE (see section 5-5-9 on page 5-30). Then press the ↑ or ↓ key to display the screen at right.	<table border="1"> <tr> <td></td> <td></td> <td>12.3 %</td> </tr> <tr> <td>#</td> <td>EX</td> <td>300.0</td> </tr> <tr> <td>MTG</td> <td>DIA</td> <td>050.0</td> </tr> </table>			12.3 %	#	EX	300.0	MTG	DIA	050.0
		12.3 %									
#	EX	300.0									
MTG	DIA	050.0									
2	Press the → key to set the detector constant. Using the ↑ or ↓ key, enter the numeric value found in the EX column stamped on the nameplate of the detector to be combined.	<table border="1"> <tr> <td></td> <td></td> <td>12.3 %</td> </tr> <tr> <td>#</td> <td>EX</td> <td>3<u>20</u>.0</td> </tr> <tr> <td>MTG</td> <td>DIA</td> <td>050.0</td> </tr> </table>			12.3 %	#	EX	3 <u>20</u> .0	MTG	DIA	050.0
		12.3 %									
#	EX	3 <u>20</u> .0									
MTG	DIA	050.0									
3	In addition, press the → key to select the detector type. Using the ↑ or ↓ key, select the detector type. To measure the flow rate, select MTG. To perform adjustments and loop checks, select TST.	<table border="1"> <tr> <td></td> <td></td> <td>12.3 %</td> </tr> <tr> <td>#</td> <td>EX</td> <td>320.0</td> </tr> <tr> <td><u>MTG</u></td> <td>DIA</td> <td>050.0</td> </tr> </table>			12.3 %	#	EX	320.0	<u>MTG</u>	DIA	050.0
		12.3 %									
#	EX	320.0									
<u>MTG</u>	DIA	050.0									
4	Then press the → key to select the bore diameter. Using the ↑ or ↓ key, select the bore diameter of the detector.	<table border="1"> <tr> <td></td> <td></td> <td>12.3 %</td> </tr> <tr> <td>#</td> <td>EX</td> <td>320.0</td> </tr> <tr> <td>MTG</td> <td>DIA</td> <td>100.<u>0</u></td> </tr> </table>			12.3 %	#	EX	320.0	MTG	DIA	100. <u>0</u>
		12.3 %									
#	EX	320.0									
MTG	DIA	100. <u>0</u>									
5	Using the → key, move the cursor to the position under #. Press the MODE key to return to the MEASURING MODE and save data.	<table border="1"> <tr> <td></td> <td></td> <td>12.3 %</td> </tr> <tr> <td><u>#</u></td> <td>EX</td> <td>320.0</td> </tr> <tr> <td>MTG</td> <td>DIA</td> <td>100.0</td> </tr> </table>			12.3 %	<u>#</u>	EX	320.0	MTG	DIA	100.0
		12.3 %									
<u>#</u>	EX	320.0									
MTG	DIA	100.0									

CAUTION

You have only ten minutes to return to MEASURING MODE to save the new value before the system resets it to the previously saved value.

5-6-4 : Setting flow rate range

Set the flow rate range. The lower limit of the range is ZERO. The upper limit, which is the value when the output reaches 100%, is entered here along with the selection of engineering and time units. The range has an upper limit value of 10 m/s in flow velocity when it is calculated at the upper stage of the display. It has a lower limit value of 0.3 m/s.

Set the flow rate range so that the regular flow rate to greater than or equal to 50% of the flow rate range.

Pressing the MODE key automatically deletes unnecessary zeros, if any, from the flow rate range.

Example: 07.069 → 7.0690 (Unnecessary zero is deleted.)

Setting range:

Flow rate range: 0 to 0.0001, 0 to 99999.

Units of flow rate:

Unit of SI volume flow rate: m³, l, cm³

Unit of SI mass flow rate: t, kg, g

Unit of non-SI volume flow rate: mG, G, kG, B, mIG, IG, kIG

Unit of SI mass flow rate: lb

Unit of time: d, h, min., s

Default: 10.000 m³/h

Set the flow rate range in accordance with the following procedure:

Step	Procedure	Screen
1	Enter ENGINEERING MODE in accordance with the entry into ENGINEERING MODE (see section 5-5-9 on page 5-30). Then press the ↑ or ↓ key to display the screen at right.	<div style="border: 1px solid black; padding: 5px; width: fit-content;"> <div style="text-align: right;">12.3 %</div> <div># 1.4147 m/s</div> <div>SPAN 10.000 m³/h</div> </div>
2	Press the → key to move the cursor to a desired digit to be set.	<div style="border: 1px solid black; padding: 5px; width: fit-content;"> <div style="text-align: right;">12.3 %</div> <div># 1.4147 m/s</div> <div>SPAN <u>10.000</u> m³/h</div> </div>
3	Using the ↑ or ↓ key, change the value to a desired one.	<div style="border: 1px solid black; padding: 5px; width: fit-content;"> <div style="text-align: right;">12.3 %</div> <div># 1.4147 m/s</div> <div>SPAN 20.000 m³/h</div> </div>
4	In addition, press the → key to move the cursor to the position under a desired flow rate unit. Using the ↑ or ↓ key, select the unit.	<div style="border: 1px solid black; padding: 5px; width: fit-content;"> <div style="text-align: right;">12.3 %</div> <div># 1.4147 m/s</div> <div>SPAN 20.000 <u>l</u>/h</div> </div>
5	Then press the → key to move the cursor to the position under the time unit. Using the ↑ or ↓ key, select the unit.	<div style="border: 1px solid black; padding: 5px; width: fit-content;"> <div style="text-align: right;">12.3 %</div> <div># 1.4147 m/s</div> <div>SPAN 333.33/<u>min</u></div> </div>
6	Press the → key to move the cursor to the position under #. Press MODE key to return to the MEASURING MODE, and to save data.	<div style="border: 1px solid black; padding: 5px; width: fit-content;"> <div style="text-align: right;">12.3 %</div> <div><u>#</u> 1.4147 m/s</div> <div>SPAN 333.33/<u>min</u></div> </div>

⚠ CAUTION

You have only ten minutes to return to MEASURING MODE to save the new value before the system resets it to the previously saved value.

5-6-5 : Setting and changing compensation coefficient

This function is used to set or change the compensation coefficient which is used to multiply the output flow rate as required.

Set range: 0.10000 to 5.9999

Default: 1.0000

Set and change a compensation coefficient in accordance with the following procedure:

Step	Procedure	Screen
1	Enter ENGINEERING MODE in accordance with the entry into ENGINEERING MODE (see section 5-5-9 on page 5-30). Then press the ↑ or ↓ key to display the screen at right.	<div style="border: 1px solid black; padding: 5px; text-align: right;"> 12.3 % # COEFFICIENT 1.0000 </div>
2	Press the → key to move the cursor to the position under a desired value to be set or changed.	<div style="border: 1px solid black; padding: 5px; text-align: right;"> 12.3 % # COEFFICIENT 1.00<u>0</u> </div>
3	Using the ↑ or ↓ key, change the value to the desired one to be set.	<div style="border: 1px solid black; padding: 5px; text-align: right;"> 12.3 % # COEFFICIENT 1.00<u>5</u>0 </div>
4	Press the → key to move the cursor to the position under #. Press the MODE key to return to the MEASURING MDOE and to save data.	<div style="border: 1px solid black; padding: 5px; text-align: right;"> 12.3 % # COEFFICIENT 1.0050 </div>

⚠ CAUTION

You have only ten minutes to return to MEASURING MODE to save the new value before the system resets it to the previously saved value.

5-6-6 : Setting specific gravity

This function is used to set the specific gravity when selecting a weight unit (t, kg, g, lb) in the flow rate range setting.

Set range: 0.1000 to 5.9999

Default: 1.0000

Set the specific gravity in accordance with the following procedure:

Step	Procedure	Screen
1	Enter ENGINEERING MODE in accordance with the entry into ENGINEERING MODE (see section 5-5-9 on page 5-30). Then press the ↑ or ↓ key to display the screen at right.	<div style="border: 1px solid black; padding: 5px; width: fit-content;"> <div style="text-align: right;">12.3 %</div> <div># GRAVITY</div> <div style="text-align: right;">1.0000</div> </div>
2	Press the → key to move the cursor to the position under a desired value to be set or changed.	<div style="border: 1px solid black; padding: 5px; width: fit-content;"> <div style="text-align: right;">12.3 %</div> <div># GRAVITY</div> <div style="text-align: right;">1.00<u>0</u></div> </div>
3	Using the ↑ or ↓ key, change the value to the desired one to be set.	<div style="border: 1px solid black; padding: 5px; width: fit-content;"> <div style="text-align: right;">12.3 %</div> <div># GRAVITY</div> <div style="text-align: right;">1.00<u>5</u>0</div> </div>
4	Press the → key to move the cursor to the position under #. Press the MODE key to return to the MEASURING MODE and to save data.	<div style="border: 1px solid black; padding: 5px; width: fit-content;"> <div style="text-align: right;">12.3 %</div> <div># GRAVITY</div> <div style="text-align: right;">1.0050</div> </div>

⚠ CAUTION

You have only ten minutes to return to MEASURING MODE to save the new value before the system resets it to the previously saved value.

5-6-7 : Setting pulse scale

This function is used to set the flow rate per pulse and associated units for a flowmeter. Pulse scale of the totalization value indicated on the display is equal to the pulse scale set here.

Set range: 0.0001 to 99999.

However, the pulse scale should be set so that the pulse output span frequency f_s (shown in the auxiliary display) is between 0.0001 Hz and 200 Hz.

$$0.0001 \text{ Hz} \leq f_s \leq 200 \text{ Hz}$$

Units of flow rate:

Unit of SI volume flow rate: $\text{m}^3, \text{l}, \text{cm}^3$

Unit of SI mass flow rate: $\text{t}, \text{kg}, \text{g}$

Unit of non-SI volume flow rate: $\text{mG}, \text{G}, \text{kG}, \text{B}, \text{mIG}, \text{IG}, \text{kIG}$

Unit of SI mass flow rate: lb

Unit of time: $\text{d}, \text{h}, \text{min.}, \text{s}$

Default: $10.000 \text{ m}^3/\text{P}$

~Note *Select the same unit systems (volume unit or mass unit) for the flow rate range and pulse scale. Selection of different unit systems for them will cause set errors (Err-22 PULSE WEIGHT SETTING ERROR). (See page 5-64.)*

Calculation method of span frequency:

Span frequency f_s can be calculated by the following formula:

$$f_s = (\text{Flow rate range}) / (\text{Pulse scale})$$

To calculate f_s , pay attention to the following points:

- * Convert flow range into the range per second.
- * Select the same unit of flow rate for flow rate range and pulse scale.

Example) When flow rate range: 60 l/min., and pulse scale: $10 \text{ cm}^3/\text{P}$:

1. Convert the flow rate range into the flow rate range per second.

$$60 \text{ l/min.} \rightarrow 60/60 \text{ l/s}$$

$$= 1 \text{ l/s}$$

2. Select the same unit of flow rate for flow rate range and pulse scale.

In this example, the unit of pulse scale is changed.

$$10 \text{ cm}^3/\text{P} \rightarrow 10/1000 \text{ l/P}$$

$$= 0.01 \text{ l/P}$$

3. Calculate the span frequency.

$$(1 \text{ l/P}) / (0.01 \text{ l/P})$$

$$= 100 \text{ Hz}$$

$$f_s = 100 \text{ Hz}$$

Set pulse scale in accordance with the following procedure:

Step	Procedure	Screen						
1	Enter ENGINEERING MODE in accordance with the entry into ENGINEERING MODE (see section 5-5-9 on page 5-30). Then press the ↑ or ↓ key to display the screen at right.	<table border="1"> <tr> <td></td> <td>12.3 %</td> </tr> <tr> <td># PLS</td> <td>27.780 Hz</td> </tr> <tr> <td>SCL</td> <td>100.00 l/p</td> </tr> </table>		12.3 %	# PLS	27.780 Hz	SCL	100.00 l/p
	12.3 %							
# PLS	27.780 Hz							
SCL	100.00 l/p							
2	Press the → key to move the cursor to the position under a desired value to be set or changed.	<table border="1"> <tr> <td></td> <td>12.3 %</td> </tr> <tr> <td># PLS</td> <td>27.780 Hz</td> </tr> <tr> <td>SCL</td> <td><u>100.00</u> l/p</td> </tr> </table>		12.3 %	# PLS	27.780 Hz	SCL	<u>100.00</u> l/p
	12.3 %							
# PLS	27.780 Hz							
SCL	<u>100.00</u> l/p							
3	Using the ↑ or ↓key, change the value to a desired pulse scale to be set.	<table border="1"> <tr> <td></td> <td>12.3 %</td> </tr> <tr> <td># PLS</td> <td>13.890 Hz</td> </tr> <tr> <td>SCL</td> <td><u>200.00</u> l/p</td> </tr> </table>		12.3 %	# PLS	13.890 Hz	SCL	<u>200.00</u> l/p
	12.3 %							
# PLS	13.890 Hz							
SCL	<u>200.00</u> l/p							
4	Press the → key to move the cursor to the position under #. Press the MODE key to return to the MEASURING MDOE and to save data.	<table border="1"> <tr> <td></td> <td>12.3 %</td> </tr> <tr> <td># PLS</td> <td>13.890 Hz</td> </tr> <tr> <td>SCL</td> <td>200.00 l/p</td> </tr> </table>		12.3 %	# PLS	13.890 Hz	SCL	200.00 l/p
	12.3 %							
# PLS	13.890 Hz							
SCL	200.00 l/p							

⚠ CAUTION
You have only ten minutes to return to MEASURING MODE to save the new value before the system resets it to the previously saved value.

5-6-8 : Setting pulse width

Set a pulse width. The pulse width should be set in accordance with the specifications of the pulse receiver installed.

Set range

DUTY 50%

Pulse width that is DUTY 50% of the span frequency, and 1,000 ms (1s) maximum. The pulse duty ratio defines the pulse ON time versus the pulse OFF time as a percentage of the total pulse cycle.

NUM (setting of a real value)

0001 to 1,000 ms (1 s)

* With DUTY 50%, no setting error appears.

* With NUM (with a real value set), a setting error occurs if the pulse width exceeds the DUTY ratio of 70% in span frequency.

Default:

DUTY 50%

Method of setting pulse width:

The DUTY ratio is B/A (%) in the diagram at right.

1. NUM (when real pulse width is selected)

DUTY ratio < 70%

Set the pulse width as shown above.

Calculation method: When the range is 360 m³, and pulse scale is 2 l/P,

First convert the unit of range to calculate the span frequency.

Convert the range into the unit of per-second (/s).

$$360 \text{ m}^3/\text{s} \rightarrow 0.1 \text{ m}^3/\text{s}$$

Convert the unit of flow rate range to be same as the unit of pulse scale.

$$0.1 \text{ m}^3/\text{s} \rightarrow 0.1 * 1000 \text{ l/s} \\ 100 \text{ l/s}$$

Calculation of span frequency

$$(100 \text{ l/s}) / (2 \text{ l/P})$$

$$= 50 \text{ Hz}$$

$$50 \text{ Hz} \rightarrow 20 \text{ ms (= A)}$$

Calculation of pulse width where the DUTY ratio is equivalent to 70%

$$B = 0.7 \times A$$

$$= 0.7 \times 20 \text{ ms}$$

$$= 14 \text{ ms}$$

Therefore, set the pulse width to less than 14 ms.

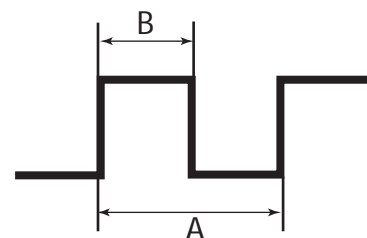

2. DUTY 50% (Automatically set)

Selecting DUTY 50% automatically sets the pulse width as follows:

Calculation method 1

Make calculations to obtain a pulse width that is DUTY 50% of the span frequency. The pulse width is automatically set. In this case, the calculated value of the pulse width does not appear on the display.

Calculation method 2

In addition, if the pulse width calculated by the calculation method 1 exceeds 1 second, the pulse width is set to 1 second.

Calculation method 1: When the range is 360 m³/h, and pulse scale is 2 l/P,

First convert the unit of range to calculate the span frequency.

Convert the range into the unit of per-second (/s).

$$360 \text{ m}^3/\text{h} \rightarrow 0.1 \text{ m}^3/\text{s}$$

Convert the unit of flow rate range to be same as the unit of pulse scale.

$$0.1 \text{ m}^3/\text{s} \rightarrow 0.1 \times 1000 \text{ l/s} \\ 100 \text{ l/s}$$

Calculation of span frequency

$$(100 \text{ l/s}) / (2 \text{ l/P})$$

$$= 50 \text{ Hz}$$

$$50 \text{ Hz} \rightarrow 20 \text{ ms} (= A)$$

Calculation of pulse width where the DUTY ratio is equivalent to 50%

$$B = 0.5 \times A \\ = 0.5 \times 20 \text{ ms} \\ = 10 \text{ ms}$$

Therefore, the pulse width is 10 ms.

Calculation method 2: When the range is 36 m³/h, and pulse scale is 100 l/P,

First convert the unit of range to calculate the span frequency.

Convert the range into the unit of per-second (/s).

$$36 \text{ m}^3/\text{h} \rightarrow 0.01 \text{ m}^3/\text{s}$$

Convert the unit of flow rate range to be same as unit of pulse scale.

$$0.01 \text{ m}^3/\text{s} \rightarrow 0.01 \times 1000 \text{ l/s} \\ 10 \text{ l/s}$$

Calculation of span frequency

$$(10 \text{ l/s}) / (100 \text{ l/p})$$

$$= 0.1 \text{ Hz}$$

$$0.1 \text{ Hz} \rightarrow 10 \text{ s} (= A)$$

Calculation of pulse width where the DUTY ratio is equivalent to 50%

$$B = 0.5 \times A \\ = 0.5 \times 10 \text{ s} \\ = 5 \text{ s}$$

Because the calculated pulse width exceeds 1 s, it takes 1s.

Set a pulse width in accordance with the following procedure:

Step	Procedure	Screen
1	Enter ENGINEERING MODE in accordance with the entry into ENGINEERING MODE (see section 5-5-9 on page 5-30). Then press the ↑ or ↓ key to display the screen at right.	<pre> 12.3 % # PLS 27.778 % WID NUM 010.00ms </pre>
2	Press the → key to move the cursor to the position under NUM.	<pre> 12.3 % # PLS 27.778 % WID <u>N</u>UM 010.00ms </pre>
3	Pressing the ↑ key switches a screen for entering a numeric value for pulse width to a screen for fixing the DUTY ratio to 50%.	<pre> 12.3 % # PLS WID <u>D</u>UTY 50 % </pre>
4	To enter a numeric value for pulse width, press the ↑ key to return to the screen for the entry of numeric values. Using the → key, move the cursor to the position under a desired digit to be set.	<pre> 12.3 % # PLS 27.778 % WID NUM 01<u>0</u>.00ms </pre>
5	Using the ↑ or ↓ key, change the value to a desired value to be set.	<pre> 12.3 % # PLS 13.889 % WID NUM 00<u>5</u>.00ms </pre>
6	Press the → key to move the cursor to the position under #. Press the MODE key to return to the MEASURING MODE and to save data.	<pre> 12.3 % # PLS 13.889 % WID NUM 005.00ms </pre>

⚠ CAUTION

You have only ten minutes to return to MEASURING MODE to save the new value before the system resets it to the previously saved value.

5-6-9 : Setting drop out

This function is used to set the drop out value for the pulse output. The pulse output will be cut off at this point to avoid flow pulsation in range values close to zero, thus preventing incorrect totalization of the flow rate.

Pulse counting pauses when the flow rate reaches this preset percentage of the set range.

Setting range: 0 to 10%

Default: 2%

Set drop out in accordance with the following procedure:

Step	Procedure	Screen
1	Enter ENGINEERING MODE in accordance with the entry into ENGINEERING MODE (see section 5-5-9 on page 5-30). Then press the ↑ or ↓ key to display the screen at right.	<div style="border: 1px solid black; padding: 5px; display: inline-block;"> <div style="text-align: right;">12.3 %</div> <div># DROPOUT</div> <div style="text-align: right;">02 %</div> </div>
2	Press the → key.	<div style="border: 1px solid black; padding: 5px; display: inline-block;"> <div style="text-align: right;">12.3 %</div> <div># DROPOUT</div> <div style="text-align: right;">0<u>2</u> %</div> </div>
3	Using the ↑ or ↓ key, change the value to a desired value to be set.	<div style="border: 1px solid black; padding: 5px; display: inline-block;"> <div style="text-align: right;">12.3 %</div> <div># DROPOUT</div> <div style="text-align: right;">0<u>5</u> %</div> </div>
4	Press the → key to move the cursor to the position under #. Press the MODE key to return to the MEASUREMENT MODE and to save data.	<div style="border: 1px solid black; padding: 5px; display: inline-block;"> <div style="text-align: right;">12.3 %</div> <div># DROPOUT</div> <div style="text-align: right;">05 %</div> </div>

⚠ CAUTION

You have only ten minutes to return to MEASURING MODE to save the new value before the system resets it to the previously saved value.

5-6-10 : Setting low flow cutoff

This function is used to set the low flow cutoff value. When the flow rate reaches the entered value, the analog output is cut off and latched to 4 mA (display flow rate of 0%) to avoid errors due to flow pulsation in range value close to zero.

Also, for reverse flow rate the output is latched to 4 mA (display flow rate of 0%)

The lower limit of the low flow cutoff setting is determined by the velocity range.

1. If the velocity range exceeds 3 m/s, the lower limit value is 1%.
2. If the flow speed range is 3 m/s or less, the lower limit value will cut the flow speed of 0.03 m/s or less flow the rate.

Example: If the flow speed range is set as 2 m/s, the lower limit of the low flow cutoff value is 1.5%. ($= 0.03/2 = 0.015 = 1.5\%$)

Setting range: 1 to 10%

Default: Depends on the velocity range.

Set low flow cut in accordance with the following procedure:

Step	Procedure	Screen
1	Enter ENGINEERING MODE in accordance with the entry into ENGINEERING MODE (see section 5-5-9 on page 5-30). Then press the ↑ or ↓ key to display the screen at right.	<div style="border: 1px solid black; padding: 5px; text-align: right;"> 12.3 % # LOW-FLOW CUT 02 % </div>
2	Press the → key. The cursor then moves to the position of the low flow cut value.	<div style="border: 1px solid black; padding: 5px; text-align: right;"> 12.3 % # LOW-FLOW CUT 0<u>2</u> % </div>
3	Using the ↑ or ↓ key, change the value to a desired value to be set.	<div style="border: 1px solid black; padding: 5px; text-align: right;"> 12.3 % # LOW-FLOW CUT 0<u>5</u> % </div>
4	Press the → key to move the cursor to the position under #. Press the MODE key to return to MEASURING MODE and to save data.	<div style="border: 1px solid black; padding: 5px; text-align: right;"> 12.3 % # LOW-FLOW CUT 05 % </div>

⚠ CAUTION

You have only ten minutes to return to MEASURING MODE to save the new value before the system resets it to the previously saved value.

5-6-11 : Setting upper and lower limit alarm

This function is used to set the upper and lower limit alarm set points when the contact output is selected.

An alarm is output when the flow rate exceeds these preset upper and lower limits.

The alarm output status depends on the “Setting contact output status” described later.

Set range: HI-ALM 0% to +115%
 LO-ALM 0% to +115%

Default: HI-ALM +115%
 LO-ALM 0%

Set the upper/lower limit alarm in accordance with the following procedure:

Step	Procedure	Screen						
1	Enter ENGINEERING MODE in accordance with the entry into ENGINEERING MODE (see section 5-5-9 on page 5-30). Then press the ↑ or ↓ key to display the screen at right.	<table border="1"> <tr> <td></td> <td>12.3 %</td> </tr> <tr> <td># HI-ALM</td> <td>+115%</td> </tr> <tr> <td>LO-ALM</td> <td>+000%</td> </tr> </table>		12.3 %	# HI-ALM	+115%	LO-ALM	+000%
	12.3 %							
# HI-ALM	+115%							
LO-ALM	+000%							
2	Using the → key, move the cursor to the position under a digit to be set or changed.	<table border="1"> <tr> <td></td> <td>12.3 %</td> </tr> <tr> <td># HI-ALM</td> <td>+1<u>0</u>0%</td> </tr> <tr> <td>LO-ALM</td> <td>-000%</td> </tr> </table>		12.3 %	# HI-ALM	+1 <u>0</u> 0%	LO-ALM	-000%
	12.3 %							
# HI-ALM	+1 <u>0</u> 0%							
LO-ALM	-000%							
3	Using the ↑ or ↓ key, change the value to the desired value to be set.	<table border="1"> <tr> <td></td> <td>12.3 %</td> </tr> <tr> <td># HI-ALM</td> <td>+0<u>8</u>0%</td> </tr> <tr> <td>LO-ALM</td> <td>-000%</td> </tr> </table>		12.3 %	# HI-ALM	+0 <u>8</u> 0%	LO-ALM	-000%
	12.3 %							
# HI-ALM	+0 <u>8</u> 0%							
LO-ALM	-000%							
4	Press the → key to move the cursor to the position under #. Press MODE key to return to the MEASURING MODE and to save data.	<table border="1"> <tr> <td></td> <td>12.3 %</td> </tr> <tr> <td># HI-ALM</td> <td>+080%</td> </tr> <tr> <td>LO-ALM</td> <td>-000%</td> </tr> </table>		12.3 %	# HI-ALM	+080%	LO-ALM	-000%
	12.3 %							
# HI-ALM	+080%							
LO-ALM	-000%							

However, set as follows: HI-ALM > LO-ALM.

5-6-12 : Selecting failsafe mode for analog outputs

This function is used to determine the analog output direction when the flowmeter detects a critical status condition.

⚠ CAUTION

The failsafe mode is very important for the overall safety of the control process. Choose the failsafe direction carefully, as equipment damage can result from a wrong choice.

Setting range: LOW Analog output is driven to low scale (TYP 3.7 mA)

HIGH Analog output is driven to high scale (TYP 21.8 mA)

HOLD Analog output is held at its last good value.

Default: LOW

Set failsafe mode for analog output in accordance with the following procedure:

Step	Procedure	Screen
1	Enter ENGINEERING MODE in accordance with the entry into ENGINEERING MODE (see section 5-5-9 on page 5-30). Then press the ↑ or ↓ key to display the screen at right.	<div style="border: 1px solid black; padding: 5px; text-align: right;"> 12.3 % # ERROR OUT MODE I.OUT LOW </div>
2	Press the → key.	<div style="border: 1px solid black; padding: 5px; text-align: right;"> 12.3 % # ERROR OUT MODE I.OUT <u>L</u>OW </div>
3	Using the ↑ or ↓ key, determine the failsafe mode for analog output.	<div style="border: 1px solid black; padding: 5px; text-align: right;"> 12.3 % # ERROR OUT MODE I.OUT <u>H</u>IGH </div>
4	Press the → key to move the cursor to the position under #. Press the MODE key to return to the MEASURING MODE and to save data.	<div style="border: 1px solid black; padding: 5px; text-align: right;"> 12.3 % # ERROR OUT MODE I.OUT HIGH </div>

⚠ CAUTION

You have only ten minutes to return to MEASURING MODE to save the new value before the system resets it to the previously saved value.

5-6-13 : Selecting failsafe mode for pulse output

This function is used to determine the pulse output direction when the flowmeter detects a critical status condition.

⚠ CAUTION
The failsafe mode is very important for the overall safety of the control process. Choose the failsafe direction carefully, as equipment damage can result from a wrong choice.

Set range: OFF Outputs no pulse.
 HOLD Pulse output signal held at its present state
 Default: OFF

Set failsafe mode for pulse output in accordance with the following procedure:

Step	Procedure	Screen
1	Enter ENGINEERING MODE in accordance with the entry into ENGINEERING MODE (see section 5-5-9 on page 5-30). Then press the ↑ or ↓ key to display the screen at right.	<div style="text-align: right;">12.3 %</div> <div># ERROR OUT MODE</div> <div>P.OUT OFF</div>
2	Press the → key.	<div style="text-align: right;">12.3 %</div> <div># ERROR OUT MODE</div> <div>P.OUT <u>OFF</u></div>
3	Using the ↑ or ↓ key, determine the failsafe mode for pulse output.	<div style="text-align: right;">12.3 %</div> <div># ERROR OUT MODE</div> <div>P.OUT <u>HOLD</u></div>
4	Press the → key to move the cursor to the position under #. Press the MODE key to return to the MEASURING MODE and to save data.	<div style="text-align: right;">12.3 %</div> <div># ERROR OUT MODE</div> <div>P.OUT HOLD</div>

⚠ CAUTION
You have only ten minutes to return to MEASURING MODE to save the new value before the system resets it to the previously saved value.

5-6-14 : Setting contact output status

This function is used to set contact output status for normal operation.

This function is effective only when contact output has been selected in the function specification.

Set range: CLOSE Sets the open collector output to ON.

OPEN Sets the open collector output to OFF.

Default: OPEN

Set the contact output status in accordance with the following procedure:

Step	Procedure	Screen
1	Enter ENGINEERING MODE in accordance with the entry into ENGINEERING MODE (see section 5-5-9 on page 5-30). Then press the ↑ or ↓ key to display the screen at right.	<div style="border: 1px solid black; padding: 5px; width: fit-content;"> <div style="text-align: right;">12.3 %</div> # ST. OUT MODE NORMAL CLOSE </div>
2	Press the → key.	<div style="border: 1px solid black; padding: 5px; width: fit-content;"> <div style="text-align: right;">12.3 %</div> # ST. OUT MODE NORMAL <u>C</u>LOSE </div>
3	Using the ↑ key, set the contact output status.	<div style="border: 1px solid black; padding: 5px; width: fit-content;"> <div style="text-align: right;">12.3 %</div> # ST. OUT MODE NORMAL <u>O</u>PEN </div>
4	Press the → key to move the cursor to the position under #. Press the MODE key to return to the MEASURING MODE and to save data.	<div style="border: 1px solid black; padding: 5px; width: fit-content;"> <div style="text-align: right;">12.3 %</div> # ST. OUT MODE NORMAL OPEN </div>

⚠ CAUTION

You have only ten minutes to return to MEASURING MODE to save the new value before the system resets it to the previously saved value.

5-7 : Configuration of MAINTENANCE MODE

Introduction

MAINTENANCE MODE consists of the following three types: OUTPUT CHECK MODE, CALIBRATION MODE, and CRITICAL MODE. For details on the modes, see the following pages.

LCD display flow

The LCD display flow of MAINTENACE MODE is as follows:

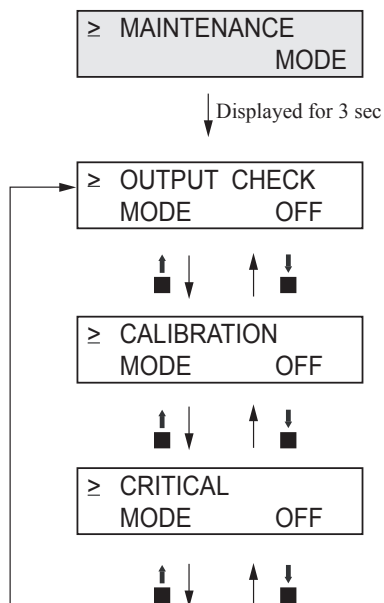

5-7-1 : Configuration of OUTPUT CHECK MODE

Introduction

OUTPUT CHECK MODE has the following setting and adjustment items.

For details on the function of items, see the following pages.

Item	Content	Screen
OUTPUT CHECK I.OUT	Outputs a fixed value of analog current output to perform loop checks.	<div style="border: 1px solid black; padding: 5px; width: fit-content;"> <div style="text-align: right;">12.3 %</div> <div style="text-align: center;">≥ OUTPUT CHECK</div> <div style="text-align: right;">I.OUT 100%</div> </div>
OUTPUT CHECK P.OUT	Outputs a fixed value of pulse output to perform loop checks.	<div style="border: 1px solid black; padding: 5px; width: fit-content;"> <div style="text-align: right;">12.3 %</div> <div style="text-align: center;">≥ OUTPUT CHECK</div> <div style="text-align: right;">P.OUT 100%</div> </div>
OUTPUT CHECK ST.OUT	Outputs a fixed value of contact output to perform loop checks.	<div style="border: 1px solid black; padding: 5px; width: fit-content;"> <div style="text-align: right;">12.3 %</div> <div style="text-align: center;">≥ OUTPUT CHECK</div> <div style="text-align: right;">ST.OUT CLOSE</div> </div>
OUTPUT CHECK EX	Outputs a fixed value of excitation current. This value was calibrated in the factory. DO NOT configure this value.	<div style="border: 1px solid black; padding: 5px; width: fit-content;"> <div style="text-align: right;">12.3 %</div> <div style="text-align: center;">≥ OUTPUT CHECK</div> <div style="text-align: right;">EX EX1</div> </div>

LCD display flow

The screen flow of OUTPUTCHECK MODE is as follows:

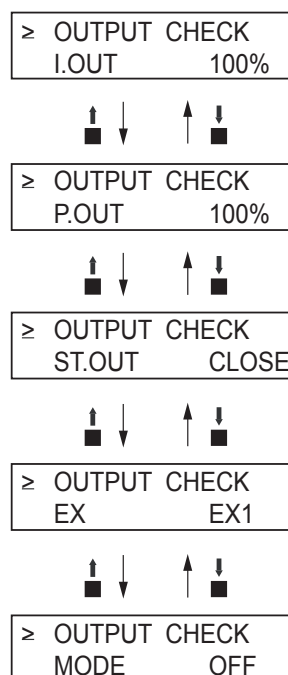

5-7-2 : Performing loop checks of analog outputs

Analog output check

The electromagnetic flowmeter can be used as a constant current generator to check analog outputs. Other instruments in the analog current output loop, such as recorders and controllers can be checked.

Default setting

Displays the current output value.

Setting range

Range settings are allowed ranging from 0 to 100%.

Perform loop checks of analog outputs in accordance with the following procedure:

Step	Procedure	Screen
1	Enter MAINTENANCE MODE in accordance with the entry into MAINTENANCE MODE (see section 5-5-9 on page 5-30). Then display the screen at right.	<div style="border: 1px solid black; padding: 5px; width: fit-content;"> <div style="text-align: right;">20.0 %</div> ≥ OUTPUT CHECK MODE OFF </div>
2	Press the → key to move the cursor to the OFF position. Press the ↑ key. With the display switched from OFF to ON, the output check mode is then active.	<div style="border: 1px solid black; padding: 5px; width: fit-content;"> <div style="text-align: right;">20.0 %</div> > OUTPUT CHECK MODE <u>OFF</u> </div> <div style="border: 1px solid black; padding: 5px; width: fit-content;"> <div style="text-align: right;">20.0 %</div> > OUTPUT CHECK MODE <u>ON</u> </div> <div style="border: 1px solid black; padding: 5px; width: fit-content;"> <div style="text-align: right;">20.0 %</div> ≥ OUTPUT CHECK I.OUT 000.0% </div>
3	Press the → key to move the cursor to the position under a desired value to be checked.	<div style="border: 1px solid black; padding: 5px; width: fit-content;"> <div style="text-align: right;">20.0 %</div> > OUTPUT CHECK I.OUT <u>000.0%</u> </div>
4	Pressing the ↑ or ↓ key, change the value to the desired value to be checked. As shown on the screen on the right, the output to the range, given as an analog output, is 100% i.e. 20 mA.	<div style="border: 1px solid black; padding: 5px; width: fit-content;"> <div style="text-align: right;">20.0 %</div> > OUTPUT CHECK I.OUT <u>100.0%</u> </div>
5	Press the → key to move the cursor to the position under >. Movement to another screen by using the ↑ or ↓ key returns to an analog output according to the actual flow rate.	<div style="border: 1px solid black; padding: 5px; width: fit-content;"> <div style="text-align: right;">20.0 %</div> ≥ OUTPUT CHECK I.OUT 100.0% </div>

5-7-3 : Performing loop checks of pulse outputs

Pulse output check

The electromagnetic flowmeter can be used as a pulse generator to check pulse outputs.

This screen appears when pulse output has been selected in FUNC SET of ENGINEERING MODE (see “5-6-2 : Selecting pulse output or contact output”).

Default setting

Displays the current output value.

Setting range

Range settings are allowed ranging from 0 to 100%.

Perform loop checks of pulse outputs in accordance with the following procedure:

Step	Procedure	Screen
1	Enter MAINTENANCE MODE in accordance with the entry into MAINTENANCE MODE (see section 5-5-9 on page 5-30). Then display the screen at right.	<div style="border: 1px solid black; padding: 5px; width: fit-content;"> <div style="text-align: right;">20.0 %</div> ≥ OUTPUT CHECK MODE OFF </div>
2	Press the → key to move the cursor to the OFF position. Press the - key. With the display switched from OFF to ON, the output check mode is then active.	<div style="border: 1px solid black; padding: 5px; width: fit-content;"> <div style="text-align: right;">20.0 %</div> > OUTPUT CHECK MODE OFF </div> <div style="border: 1px solid black; padding: 5px; width: fit-content;"> <div style="text-align: right;">20.0 %</div> > OUTPUT CHECK MODE ON </div> <div style="border: 1px solid black; padding: 5px; width: fit-content;"> <div style="text-align: right;">20.0 %</div> ≥ OUTPUT CHECK I.OUT 000.0% </div>
3	Press the ↑ key to display the screen at right.	<div style="border: 1px solid black; padding: 5px; width: fit-content;"> <div style="text-align: right;">20.0 %</div> ≥ OUTPUT CHECK P.OUT 000.0% </div>
4	Press the → key to move the cursor to the position under a desired value to be checked.	<div style="border: 1px solid black; padding: 5px; width: fit-content;"> <div style="text-align: right;">20.0 %</div> > OUTPUT CHECK P.OUT 000.0% </div>
5	Pressing the ↑ or ↓ key, change the value to the desired value to be checked. On the screen at right, a frequency pulse corresponding to flow rate signal 100% is output.	<div style="border: 1px solid black; padding: 5px; width: fit-content;"> <div style="text-align: right;">20.0 %</div> > OUTPUT CHECK I.OUT 100.0% </div>
6	Press the → key to move the cursor to the position shown on the screen at right. Movement to another screen by using the ↑ or ↓ key returns to a pulse output according to the actual flow rate.	<div style="border: 1px solid black; padding: 5px; width: fit-content;"> <div style="text-align: right;">20.0 %</div> ≥ OUTPUT CHECK I.OUT 100.0% </div>

5-7-4 : Performing loop checks of contact outputs

Contact output check

Contact outputs of electromagnetic flowmeter can be turned on and off to perform loop checks of contact output signals.

This screen appears when contact output has been selected in FUNC SET of ENGINEERING MODE (see “5-6-2 : Selecting pulse output or contact output”).

Default setting

Displays the current contact output status.

Setting range

Set range “CLOSE” and “OPEN”

Perform loop checks of contact outputs in accordance with the following procedure:

Step	Procedure	Screen
1	Enter MAINTENANCE MODE in accordance with the entry into MAINTENANCE MODE (see section 5-5-9 on page 5-30). Then display the screen at right.	<div style="border: 1px solid black; padding: 5px; width: fit-content;"> <div style="text-align: right;">20.0 %</div> ≥ OUTPUT CHECK MODE OFF </div>
2	Press the → key to move the cursor to the OFF position. Press the ↑ key. With the display switched from OFF to ON, the output check mode is then active.	<div style="border: 1px solid black; padding: 5px; width: fit-content;"> <div style="text-align: right;">20.0 %</div> > OUTPUT CHECK MODE <u>OFF</u> </div> <div style="border: 1px solid black; padding: 5px; width: fit-content;"> <div style="text-align: right;">20.0 %</div> > OUTPUT CHECK MODE <u>ON</u> </div> <div style="border: 1px solid black; padding: 5px; width: fit-content;"> <div style="text-align: right;">20.0 %</div> ≥ OUTPUT CHECK I.OUT 000.0% </div>
3	Press the ↑ key twice to display the screen at right. In this status, a contact output corresponding to the display is output.	<div style="border: 1px solid black; padding: 5px; width: fit-content;"> <div style="text-align: right;">20.0 %</div> ≥ OUTPUT CHECK ST.OUT CLOSE </div>
4	Press the → key to move the cursor to the OPEN or CLOSE position that indicates the status of contact output.	<div style="border: 1px solid black; padding: 5px; width: fit-content;"> <div style="text-align: right;">20.0 %</div> > OUTPUT CHECK ST.OUT <u>CLOSE</u> </div>
5	Press the → key to move the cursor to the position under >. Movement to another screen by using the ↑ or ↓ key returns the contact output to the output status according to the current status.	<div style="border: 1px solid black; padding: 5px; width: fit-content;"> <div style="text-align: right;">12.3 %</div> ≥ OUTPUT CHECK ST.OUT CLOSE </div>

5-7-5 : Configuration of CALIBRATION MODE

Introduction

CALIBRATION MODE has the following setting and adjustment items:

Configuration of CALIBRATION MODE requires a dedicated calibrator.

Wrong operation may hinder accurate measurements of the flow rate. To operate in this mode, contact your local Yamatake representative.

Item	Content	Screen									
CAL EX LOW 3.5 mA	Adjusts 3.5 mA excitation current.	<div style="border: 1px solid black; padding: 5px; width: fit-content;"> <table style="width: 100%; border-collapse: collapse;"> <tr> <td style="width: 10%; text-align: right;">≥</td> <td style="width: 60%;">CAL EX</td> <td style="width: 30%; text-align: right;">12.3 %</td> </tr> <tr> <td></td> <td>LOW</td> <td style="text-align: right;">OFF</td> </tr> <tr> <td></td> <td></td> <td style="text-align: right;">3.5 mA</td> </tr> </table> </div>	≥	CAL EX	12.3 %		LOW	OFF			3.5 mA
≥	CAL EX	12.3 %									
	LOW	OFF									
		3.5 mA									
CAL EX 4.9 mA	Adjusts 4.9 mA excitation current.	<div style="border: 1px solid black; padding: 5px; width: fit-content;"> <table style="width: 100%; border-collapse: collapse;"> <tr> <td style="width: 10%; text-align: right;">≥</td> <td style="width: 60%;">CAL EX</td> <td style="width: 30%; text-align: right;">12.3 %</td> </tr> <tr> <td></td> <td></td> <td style="text-align: right;">OFF</td> </tr> <tr> <td></td> <td></td> <td style="text-align: right;">4.9 mA</td> </tr> </table> </div>	≥	CAL EX	12.3 %			OFF			4.9 mA
≥	CAL EX	12.3 %									
		OFF									
		4.9 mA									
CAL EX 7.0 mA	Adjusts 7.0 mA excitation current.	<div style="border: 1px solid black; padding: 5px; width: fit-content;"> <table style="width: 100%; border-collapse: collapse;"> <tr> <td style="width: 10%; text-align: right;">≥</td> <td style="width: 60%;">CAL EX</td> <td style="width: 30%; text-align: right;">12.3 %</td> </tr> <tr> <td></td> <td></td> <td style="text-align: right;">OFF</td> </tr> <tr> <td></td> <td></td> <td style="text-align: right;">7.0 mA</td> </tr> </table> </div>	≥	CAL EX	12.3 %			OFF			7.0 mA
≥	CAL EX	12.3 %									
		OFF									
		7.0 mA									
CAL EX 11.9 mA	Adjusts 11.9 mA excitation current.	<div style="border: 1px solid black; padding: 5px; width: fit-content;"> <table style="width: 100%; border-collapse: collapse;"> <tr> <td style="width: 10%; text-align: right;">≥</td> <td style="width: 60%;">CAL EX</td> <td style="width: 30%; text-align: right;">12.3 %</td> </tr> <tr> <td></td> <td></td> <td style="text-align: right;">OFF</td> </tr> <tr> <td></td> <td></td> <td style="text-align: right;">11.9 mA</td> </tr> </table> </div>	≥	CAL EX	12.3 %			OFF			11.9 mA
≥	CAL EX	12.3 %									
		OFF									
		11.9 mA									
CAL EX 14.0 mA	Adjusts 14.0 mA excitation current.	<div style="border: 1px solid black; padding: 5px; width: fit-content;"> <table style="width: 100%; border-collapse: collapse;"> <tr> <td style="width: 10%; text-align: right;">≥</td> <td style="width: 60%;">CAL EX</td> <td style="width: 30%; text-align: right;">12.3 %</td> </tr> <tr> <td></td> <td></td> <td style="text-align: right;">OFF</td> </tr> <tr> <td></td> <td></td> <td style="text-align: right;">14.0 mA</td> </tr> </table> </div>	≥	CAL EX	12.3 %			OFF			14.0 mA
≥	CAL EX	12.3 %									
		OFF									
		14.0 mA									
CAL I.OUT LOW 4.000 mA	Adjusts 4 mA analog current output.	<div style="border: 1px solid black; padding: 5px; width: fit-content;"> <table style="width: 100%; border-collapse: collapse;"> <tr> <td style="width: 10%; text-align: right;">≥</td> <td style="width: 60%;">CAL I.OUT</td> <td style="width: 30%; text-align: right;">12.3 %</td> </tr> <tr> <td></td> <td>LOW</td> <td style="text-align: right;">OFF</td> </tr> <tr> <td></td> <td></td> <td style="text-align: right;">4.000 mA</td> </tr> </table> </div>	≥	CAL I.OUT	12.3 %		LOW	OFF			4.000 mA
≥	CAL I.OUT	12.3 %									
	LOW	OFF									
		4.000 mA									
CAL I.OUT HIGH 20.00 mA	Adjusts 20 mA analog current output.	<div style="border: 1px solid black; padding: 5px; width: fit-content;"> <table style="width: 100%; border-collapse: collapse;"> <tr> <td style="width: 10%; text-align: right;">≥</td> <td style="width: 60%;">CAL I.OUT</td> <td style="width: 30%; text-align: right;">12.3 %</td> </tr> <tr> <td></td> <td>HIGH</td> <td style="text-align: right;">OFF</td> </tr> <tr> <td></td> <td></td> <td style="text-align: right;">20.000 mA</td> </tr> </table> </div>	≥	CAL I.OUT	12.3 %		HIGH	OFF			20.000 mA
≥	CAL I.OUT	12.3 %									
	HIGH	OFF									
		20.000 mA									
CAL P.OUT FREQ 90 Hz	Adjusts 90 Hz pulse output.	<div style="border: 1px solid black; padding: 5px; width: fit-content;"> <table style="width: 100%; border-collapse: collapse;"> <tr> <td style="width: 10%; text-align: right;">≥</td> <td style="width: 60%;">CAL P.OUT</td> <td style="width: 30%; text-align: right;">12.3 %</td> </tr> <tr> <td></td> <td>FREQ</td> <td style="text-align: right;">OFF</td> </tr> <tr> <td></td> <td></td> <td style="text-align: right;">90 Hz</td> </tr> </table> </div>	≥	CAL P.OUT	12.3 %		FREQ	OFF			90 Hz
≥	CAL P.OUT	12.3 %									
	FREQ	OFF									
		90 Hz									

Item	Content	Screen
CAL GAIN ZERO	Adjusts 0 m/s gain.	<div style="border: 1px solid black; padding: 5px; width: fit-content;"> <div style="text-align: right; margin-bottom: 5px;">12.3 %</div> <div style="display: flex; justify-content: space-between;"> ≥ CAL GAIN OFF </div> <div style="display: flex; justify-content: space-between;"> ZERO READY </div> </div>
CAL GAIN 2.5 m/s	Adjusts 2.5 m/s gain.	<div style="border: 1px solid black; padding: 5px; width: fit-content;"> <div style="text-align: right; margin-bottom: 5px;">12.3 %</div> <div style="display: flex; justify-content: space-between;"> ≥ CAL GAIN OFF </div> <div style="display: flex; justify-content: space-between;"> 2.5 m/s READY </div> </div>
CAL GAIN 10.0 m/s	Adjusts 10.0 m/s gain.	<div style="border: 1px solid black; padding: 5px; width: fit-content;"> <div style="text-align: right; margin-bottom: 5px;">12.3 %</div> <div style="display: flex; justify-content: space-between;"> ≥ CAL GAIN OFF </div> <div style="display: flex; justify-content: space-between;"> 10.0 m/s READY </div> </div>

LCD display flow

The LCD display flow of CALIBRATION MODE is as follows:

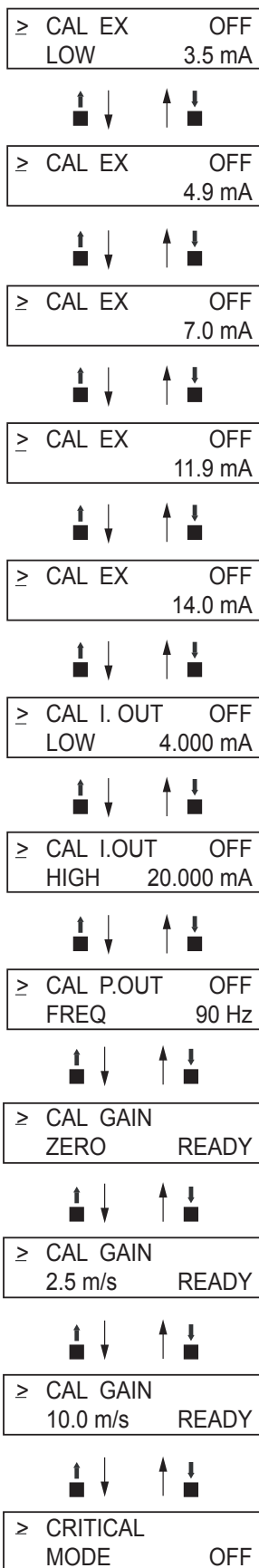

5-7-6 : Configuration of CRITICAL MODE

Introduction

CRITICAL MODE has the following setting and adjustment items:

Item	Content	Screen
ROM VER DATE	Displays the ROM version and date.	<div style="border: 1px solid black; padding: 5px; width: fit-content;"> <div style="text-align: right;">20.0 %</div> ≥ ROM VER. [] [] DATE YY-MM-DD </div>
SHIPPING DATA (default value) RECOVERY	You can return the device to factory setting/default values for pertinent operational and configuration parameters. These parameters are entered before the device is shipped, so they are commonly referred to as “shipping data”. They include factory calibration data and factory settings or initial default settings for customer configuration data.	<div style="border: 1px solid black; padding: 5px; width: fit-content;"> <div style="text-align: right;">20.0 %</div> ≥ SHIPPING DATA RECOVERY READY </div>
INITIAL DATA RECOVERY	Initial data recovery eliminates all calibration data and configuration parameters. DO NOT use this function.	<div style="border: 1px solid black; padding: 5px; width: fit-content;"> <div style="text-align: right;">20.0 %</div> ≥ INITIAL DATA RECOVERY READY </div>

LCD display flow

The screen flow of CRITICAL MODE is as follows:

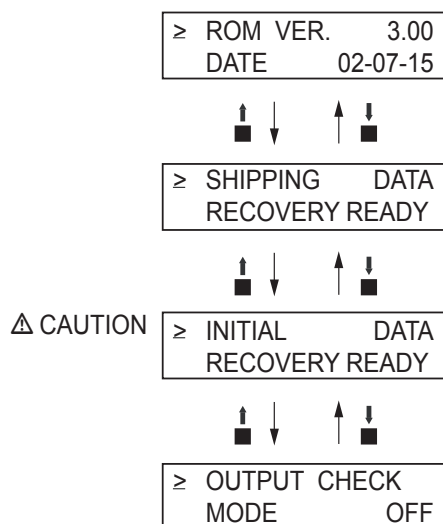

⚠ CAUTION

INITIAL DATA RECOVERY function is only for Yamatake service/maintenance specialist. Please DO NOT use this function. If this function is turned ON, all calibrated data will be missing. The device needs to be back to the factory to calibrate again.

5-7-7 : Displaying ROM version and date

Displaying ROM version

The ROM version and date of the converter can be displayed on the display screen.

Display the ROM version and data in accordance with the following procedure:

Step	Procedure	Screen
1	Enter MAINTENANCE MODE in accordance with the entry into MAINTENANCE MODE (see section 5-5-9 on page 5-30). Using the ↑ or ↓ key, display the screen at right.	<div style="border: 1px solid black; padding: 5px; width: fit-content;"> <div style="text-align: right;">20.0 %</div> ≥ OUTPUT CHECK MODE OFF </div>
2	Press the ↑ key twice to display the screen at right.	<div style="border: 1px solid black; padding: 5px; width: fit-content;"> <div style="text-align: right;">20.0 %</div> ≥ CRITICAL MODE OFF </div>
3	Press the → key to move the cursor to the OFF position. Then press the - key to switch the display from OFF to ON.	<div style="border: 1px solid black; padding: 5px; width: fit-content;"> <div style="text-align: right;">20.0 %</div> > CRITICAL MODE <u>ON</u> </div>
4	After the entry into CRITICAL MODE, the screen at right appears. On the screen, the ROM version and date can be checked.	<div style="border: 1px solid black; padding: 5px; width: fit-content;"> <div style="text-align: right;">20.0 %</div> ≥ ROM VER. [] [] DATE YY-MM-DD </div>

5-7-8 : Returning to settings at shipment

SHIPPING DATA (default value) RECOVERY

Performing SHIPPING DATA RECOVERY returns the internal data settings of the device to the settings at time of shipment.

Note that executing this operation erases the data that was set and changed by the customer.

Perform SHIPPING DATA RECOVERY in accordance with the following procedure:

Step	Procedure	Screen
1	Enter MAINTENANCE MODE in accordance with the entry into MAINTENANCE MODE (see section 5-5-9 on page 5-30). Using the ↑ or ↓ key, display the screen at right.	<div style="border: 1px solid black; padding: 5px; width: fit-content;"> <div style="text-align: right;">20.0 %</div> ≥ OUTPUT CHECK MODE OFF </div>
2	Press the ↑ key twice to display the screen at right.	<div style="border: 1px solid black; padding: 5px; width: fit-content;"> <div style="text-align: right;">20.0 %</div> ≥ CRITICAL MODE OFF </div>
3	Press the → key to move the cursor to the OFF position. Then press the ↑ key to switch the display from OFF to ON. After the entry into CRITICAL MODE, the screen at right appears.	<div style="border: 1px solid black; padding: 5px; width: fit-content;"> <div style="text-align: right;">20.0 %</div> > CRITICAL MODE <u>ON</u> </div> <div style="border: 1px solid black; padding: 5px; width: fit-content;"> <div style="text-align: right;">20.0 %</div> ≥ ROM VER. DATE YY-MM-DD </div>
4	Press the ↑ key to display the screen at right.	<div style="border: 1px solid black; padding: 5px; width: fit-content;"> <div style="text-align: right;">20.0 %</div> ≥ SHIPPING DATA RECOVERY READY </div>
5	Press the → key to move the cursor to the READY position, and then keep pressing the ↑ key for three seconds or more.	<div style="border: 1px solid black; padding: 5px; width: fit-content;"> <div style="text-align: right;">20.0 %</div> > SHIPPING DATA RECOVERY <u>READY</u> </div>
6	SHIPPING DATA RECOVER starts. The display will change as shown on the screen at right.	<div style="border: 1px solid black; padding: 5px; width: fit-content;"> <div style="text-align: right;">20.0 %</div> > SHIPPING DATA RECOVERY <u>ON</u> </div> <div style="border: 1px solid black; padding: 5px; width: fit-content;"> <div style="text-align: right;">8.8.8.8.8.8.8.8 % RATE TOTAL</div> <div style="background-color: #4a4a8a; height: 10px; width: 100%;"></div> <div style="background-color: #4a4a8a; height: 10px; width: 100%;"></div> </div> <div style="border: 1px solid black; padding: 5px; width: fit-content;"> - SELF CHECK MODE </div>
7	When SHIPPING DATA RECOVERY ends, the data settings return to those at the time of shipping, and then the MEASURING MODE screen reappears.	<div style="border: 1px solid black; padding: 5px; width: fit-content;"> <div style="text-align: right;">20.0 %</div> 01.94 m³/h WPO 00069401 </div>

5-8 : Description of Error Messages

Introduction

Errors are classified into critical failure and non-critical failure.

Critical failure

Critical failure may obstruct the electromagnetic flowmeter operation, if not corrected, ultimately damage the flowmeter. When critical failure occurs during operation, an error message will appear on the converter's display and the electromagnetic flowmeter will continue to output the preset value in the abnormality treatment (failsafe) direction. The error message and the self-diagnostic results will be visible on the display.

Perform the proper correction measures, referring to the actions below.

Error code of serious trouble

Error code	Error content	Action	LCD display
Err-02	CPU (ROM, RAM) CHECK SUM ERROR	1. Restore power. 2. Replace ROM. 3. Replace main P/C.	Err - 02 CPU CHECK ERROR
Err-04	NVM READ AFTER WRITE ERROR	1. Restore power. 2. Replace main P/C.	Err - 04 NVM CHECK ERROR

Non-critical error

Non-critical failures will not seriously affect electromagnetic flowmeter operation. When an error occurs during operation and is regarded as a non-critical problem by the converter self-diagnostics, the output will not burn-out and the electromagnetic flowmeter will continue to output the measured value.

If a wrong setting is found, an error message is displayed for a second, and then the screen set wrongly is displayed.

Error code of set errors

Error code	Error content	Action	LCD display
Err-12	Upper/lower limit alarm set error HI < LO is set.	Set HI>LO.	<div style="border: 1px solid black; padding: 5px; width: fit-content;"> Err - 12 SETTING ERROR HI<LO </div>
Err-21	Span is set to 12 m/s or more.	Check the settings of flow rate range and detector information (bore diameter and detector type).	<div style="border: 1px solid black; padding: 5px; width: fit-content;"> Err - 21 SPAN ERROR OVER 12 m/s </div>
Err-22	Pulse frequency is too large or too small. The flow rate range unit system is different from the pulse unit system. Example: SPAN m ³ /h pulse scale t/h	1. Check pulse scale. 2. Check the setting of pulse frequency. 3. Adopt a unified unit system.	<div style="border: 1px solid black; padding: 5px; width: fit-content;"> Err - 22 PULSE WEIGHT SETTING ERROR </div>
Err-23	The pulse width is too large. When pulse frequency is output, the duty is 70% or more.	Check the following settings: 1. Pulse width 2. pulse scale 3. Span	<div style="border: 1px solid black; padding: 5px; width: fit-content;"> Err - 23 PULSE WIDTH OVER DUTY 70% </div>

Chapter 6 : Operation using SFC communicator

6-1 : Structure and functions of SFC

6-1-1: Structure of SFC

Introduction

⚠ CAUTION

- When communication with the converter is started using the SFC in a system with analog output, be sure to change the control loop of the process to “manual” (manual control).
- Be sure to use the SFC with software version 7.0 or later. Using earlier versions may result in problems such as the absence of some setting items or failure in setting correctly.

~Note *Do not overcharge or over discharge (leave with the switch on) the built-in battery of the SFC. This may shorten the battery life.*

Detailed information

The SFC has been developed not only as a converter but also as a communicator to be used in connection with various smart field instruments. If you need explanation for instruments other than the loop powered magnetic flowmeter, see the model SFC160/260 User's Manual of the respective series'.

Structure of Smart Field Communicator (SFC)

Names of components

Figure 1-1 shows the structure and names of components for the Smart Field Communicator (SFC).

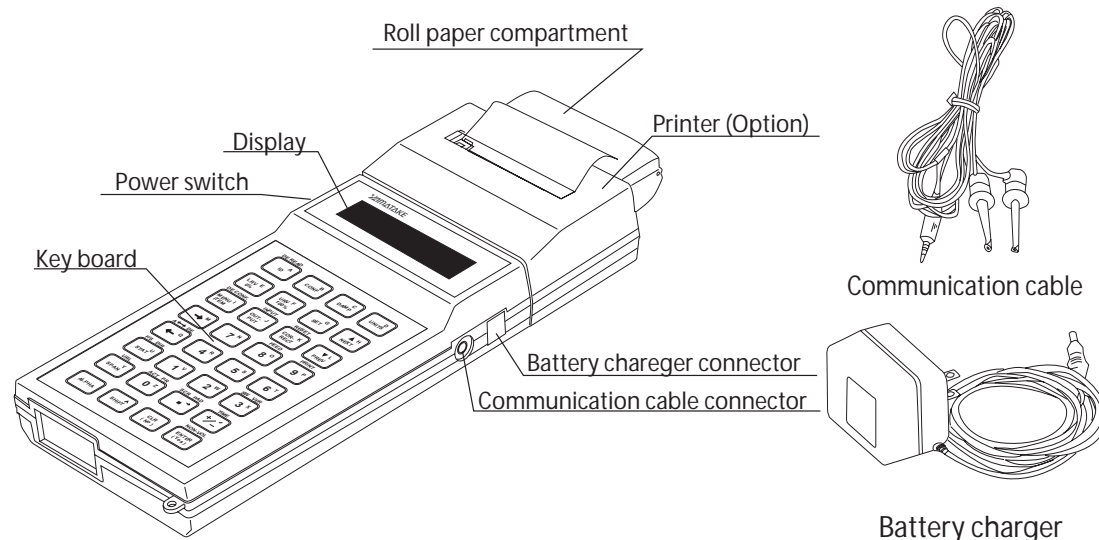



Figure 6-1 Details of SFC

Names of components and descriptions

The following table describes the components of the SFC.

Name	Description
Paper roll compartment	<ul style="list-style-type: none"> Stores heat-sensitive paper roll for print out.
Printer section (option)	<ul style="list-style-type: none"> This is an optional item. A 24 characters/line thermal printer. Prints out internal data of the converter or communication data. The printer section is combined with the main unit and cannot be separated.
Display window (screen)	<ul style="list-style-type: none"> Displays messages or data from the converter in 16 characters x 2 lines. The data display screen is available in either English or Japanese.
Power switch	<ul style="list-style-type: none"> Turning ON the power switch of the SFC automatically starts self-diagnostics.
Keyboard	<ul style="list-style-type: none"> There are 32 touch keys. Each key provides a separate function and other functions are accessed after pressing the SHIFT key. The keyboard is available in either English or Japanese version.
Communication cable connector	<ul style="list-style-type: none"> Connect the plug side of the communication cable.
Communication cable	<ul style="list-style-type: none"> Be sure to use the supplied dedicated cables.
Battery charger connector	<ul style="list-style-type: none"> Connect the plug side of the battery charger.
Battery charger	<ul style="list-style-type: none"> Charge the battery of the SFC using the supplied battery charger. <p>~Note <i>When the battery voltage drops, the following sign appears in the display window.</i></p> <div style="text-align: center;">  <p style="font-size: small; margin-top: 0;">SFCM00006001D</p> </div>

6-1-2: Functions of SFC

SFC keyboard

Key types

The SFC keyboard has 32 touch keys.

Each key is assigned to up to three types of input functions.

- The alphabet

To enter a letter of the alphabet press the  key to display the “□” cursor in the display window first. Then, press the key of the desired letter.

- Function, numeral or symbol at the center of the  key
- To access this function, numeral or symbol, make sure the “_” cursor is displayed in the display window.



Pressing the  key toggles the “□” cursor and “_” cursor.

- Function displayed on the key

To access this function, press the  key to display SHIFT in the display window first.

SHIFT-

SFCM00006002D

Then, press the key you want to enter. If you have pressed the  key by mistake, press the  key.

Key color-coding

The 32 touch keys can be roughly divided into 5 categories according to their function, and are color-coded as follows.

- Green: Mainly used to communicate with the two wired magnetic flowmeter converter or display or change the setting.
- Orange: Mainly used to communicate with the two wired magnetic flowmeter or select the screen or decide the menu.
- Yellow: Mainly used to enter numerals.
- Dark brown: Mainly used for diagnostics or check.
- White: Used to control the keyboard or for auxiliary operation.

Rules of key operations and interaction with screens









General rules for key operations

The following points should be noted when operating the SFC keyboard.

- Press keys firmly and slowly. If the screen does not respond, this means the key input has not been accepted. Press the key slowly once again.
- There are active keys and inactive keys depending on the screen in the display window. When an inactive key is pressed, pressing the  key will restore to a state in which key input can be accepted. After this, press an active key.

Interaction rules

The SFC can be operated on an interactive basis. Interact with the SFC according to the following rules:

- To answer “Yes” to a question on the screen, press the  key. Answering “Yes” to a question on the screen of the CONFIG functions normally moves to a hierarchy one level lower. However, answering “Yes” to the prompt of “EXIT...” exits the function and returns to a hierarchy one level higher.
- To answer “No” to a question on the screen, press the  key. Answering “No” to a question on the screen of the CONFIG functions normally moves to a hierarchy one level higher. However, answering “No” to the prompt of “EXIT...” returns to the start screen of the function.
- To select a different function in the same hierarchy, press  /  keys.
- To scroll the screen in order to select a different item in the same hierarchy and with the same function, press the  key. While the CONFIG function is active, pressing the  +  keys at any hierarchy will show a screen “EXIT CONFIG?”. Pressing the  key here makes it possible to exit the CONFIG function at a stroke.

Display of # mark

While the SFC is communicating with the converter, a # mark may appear in the last column at the bottom of the screen. The # mark is an alarm which appears under the following circumstances.

- A minor fault has occurred.
- The converter is operating in constant current generation mode or special mode.

When the # mark appears, check the status of the converter with the  key and take appropriate action with reference to “Error messages and remedial action” on page 6-32.

Key names and functions

This section describes the functions assigned to the green keys, which are mainly used to communicate with the two wired magnetic flowmeter converter or to change or display the settings.

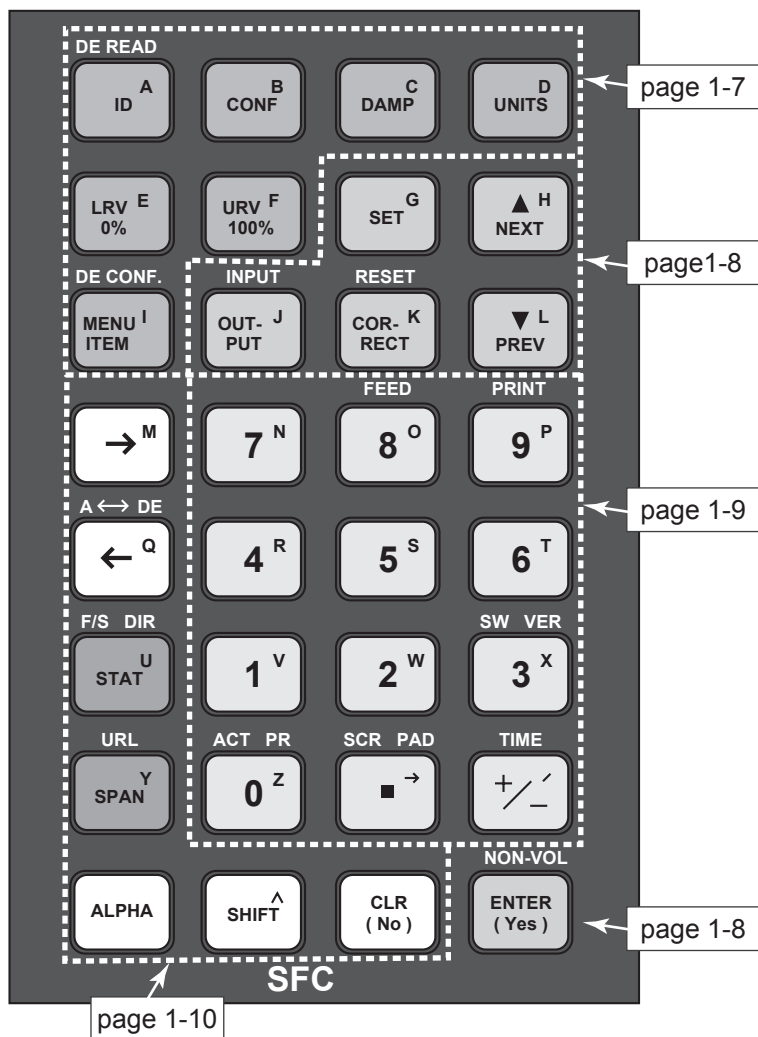











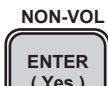

Figure 6-2 SFC keyboard

Key	Description	
	Press key	Press SHIFT + key
	ID: Starts communication with the converter. The display window shows TAG No. of the converter. It is possible to write or rewrite the TAG No. on this screen.	Used when the communication method is SFN. D. Has the same function as ID.
	CONF: Used to correct the converter or change the setting of the internal data. This function has a hierarchical structure. See “Hierarchical structure of CONFIG functions” on page 6-17 for details.	No effect
	DAMP: Press this key to display or change the damping time constant of the converter.	No effect
	UNITS: Press this key to display or set the engineering units of the flow rate measured using the converter.	No effect
	LRV 0%: Displays the lower range value of the converter output range. Fixed at 0.0% in the converter. The lower range value refers to the flow rate when the converter output becomes 0% (4 mA DC in the case of analog output).	No effect
	URV 100%: Displays the upper range value of the converter output range. The upper range value refers to the flow rate when the converter output becomes 100% (20 mA DC in the case of analog output).	No effect
	MENU ITEM: Used to display or select a different item located at the same hierarchy and with the same function.	DE CONF: Used to display or select variables output in digital communication using SFN.D for communication method.











Key names and functions

This section describes the functions assigned to the orange keys, which are mainly used to communicate with the converter or to select a screen or to select from the menu.

Key	Description	
	Press key	Press SHIFT + key
	SET: Used for setting correction coefficient in LRV setting.	No effect
	NEXT: Scrolls up the screen in the CONFIG function.	No effect
	PREV: Scrolls down the screen in the CONFIG function.	No effect
	OUTPUT: Displays a value in percentage, which is transmitted by the converter to the control loop.	INPUT: Displays an instantaneous flow rate value detected by the converter in a real flow rate.
	CORRECT: Press this key to adjust the zero point of the converter. This operation is available while INPUT (input) is being read.	RESET: Resets the internal data of the converter to the factory setting.
	ENTER: Press this key to answer "Yes" to a question on the screen. The screen will move one step up or down or data set by the SFC is written into the database of the converter.	NON-VOL: The data set by the SFC is forcibly written into non-volatile memory of the converter.







Key names and functions

This section describes the functions assigned to the yellow keys which are used to enter numerals.

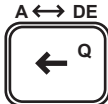
Key	Description	
	Press key	Press SHIFT + key
PRINT 	9: Enters numeral 9.	PRINT: Prints out internal data of the converter. This printing operation is called "configuration printout".
FEED 	8: Enters numeral 8.	FEED: Advances printing paper by 1 line. The display window shows "PRINTER FEED". As long as this prompt is displayed, each pressing of this key advances paper by 1 line. To cancel this operation, press the CLR key.
 to 	7 to 4: Enters numeral 7 to 4.	No effect
SW VER 	3: Enters numeral 3.	Displays the software versions of the converter and SFC. If the SFC is not communicating with the converter, only the version of the SFC is shown.
	2: Enters numeral 2.	Displays "KEYBAORD TEST row* column*" and then displays the row and column of the key pressed immediately after. Used to check the keyboard for any problems.
	1: Enters numeral 1.	No effect
ACT PR 	0: Enters numeral 0.	ACT PR: Prints out a response from the converter every time the key is operated. This operation is called "action printout".
SCR PAD 	◆: Enters a decimal point.	SCR PAD: Writes a memo into the database of the converter.
TIME 	Inverts the sign in the case of numerical input.	TIME: Displays the current year, month, day and time.

Key names and functions

This section describes the functions assigned to the dark brown and white keys which are used to diagnose or check the converter or to control the keyboard, etc.

Key	Description	
	Press key	Press SHIFT + key
	→: Moves the cursor to the right.	No effect
	←: Moves the cursor to the left.	A ↔ DE (analog ↔ digital): Switches between analog and digital communications.
	STAT: Displays self-diagnostics result of the converter.	No effect
	SPAN: Displays the span of the range of a value currently displayed.	No effect
	ALPHA: Press this key before entering a letter of the alphabet. When the “□” cursor appears on the display section, it is ready to enter. Press this key once again to enter a function or numeral displayed in the center of each key. When the display section shows a cursor, it is ready to enter this function or numeral.	No effect
	SHIFT: Press this key to enter a function displayed above each key. When the display section shows “SHIFT-”, it is ready for input.	No effect
	CLR: Clears the display in the display window and the SFC waits for input. Or press this key to answer “No” to a question on the screen. The screen moves one level up or down.	When exiting the CONFIG function, pressing this key jumps from a lower level to EXIT CONFIG at a stroke.

Charging SFC

⚠ CAUTION

When a “.” mark appears in the 8th column at the top of the SFC screen as shown below, stop using the SFC immediately and charge the SFC. Continuing to use the SFC will over discharge the battery of the SFC and make it impossible to charge it further.

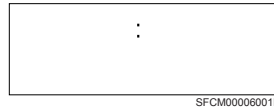

Procedure

For the procedure for charging the SFC, see the SFC User's Manual (CM2-SFC100-2001).

6-1-3: SFC Wiring

Wiring between two wired magnetic flowmeter converter and SFC

This section describes the wiring method between the two wired magnetic flowmeter converter and SFC.

Connect the SFC as shown in Figure 6-3.

Connect the SFC red terminal to I.OUT+ and the black terminal to I.OUT-.

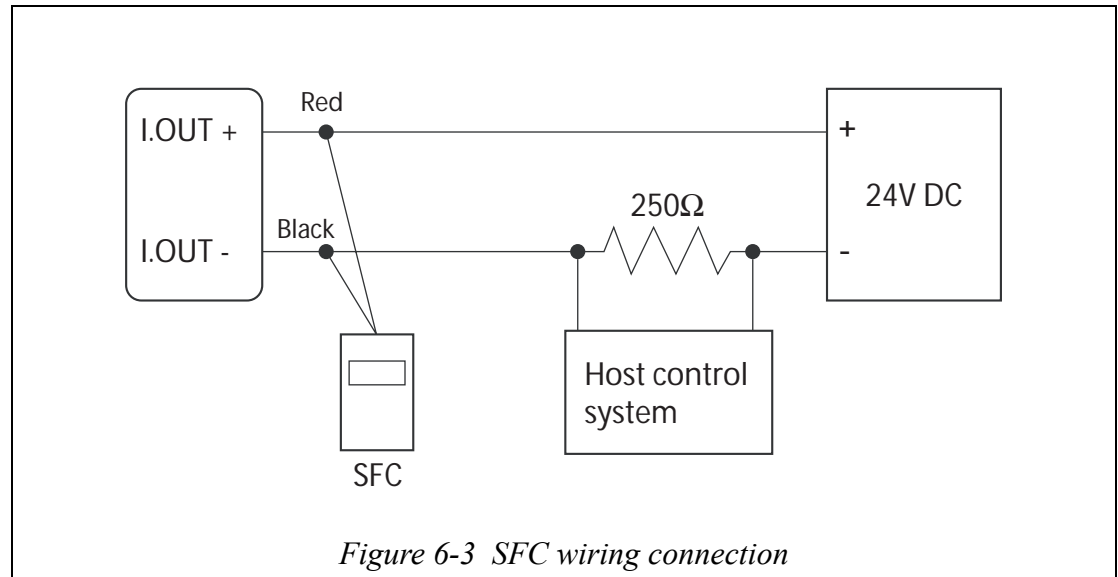

6-1-4: SFC unavailable functions

There are functions which cannot be set or changed from SFC in two wired magnetic flowmeter functions. These function settings or changing can be key operated from the data setting device. To operate these functions, refer to “Chapter 5 : Operation using the data setting device”.

Functions which cannot be set or changed using the SFC are,

- Auto spike cut
- Moving average processing
- Moving average processing time
- Pulse output adjustment
- Excitation current adjustment

6-1-5: Before operating SFC

Before SFC operation, please read the following:

Status of two wired magnetic flowmeter SFC at SFC communication

Make sure that the two wired magnetic flowmeter is in the Measuring Mode while setting it using the SFC communication.

If communicating with the other mode, SFC will display “IN LOCAL MODE” on the screen and you cannot set or change using SFC communication. In this case, change the two wired magnetic flowmeter in the field to Measuring mode and then, try to communicate again.

Two wired magnetic flowmeter will take this status “LOCAL”, as someone setting or changing by touch sensor in the field. This is to prevent the setting and changing operation from both sides.

Confirm write protect mode

Two wired magnetic flowmeter has a write protect function. Write protect function is to prevent access to unauthorized persons and to prevent performing wrong operation. Write protect can be set by the customer by setting the arbitrary 4 levels.

Please make sure that when write protect level is WP0, reading and writing are available and when write protect level is WP1, 2 or 3, only reading is available.

The protection details are shown by write protect levels.

Write protect level	SW1	SW2	LSC (Key operation)			Communication		
			Operator's mode	Engineering mode	Maintenance mode	Operator's mode	Engineering mode	Maintenance mode
0	OFF	OFF	R/W ENABLE	R/W ENABLE	R/W ENABLE	R/W ENABLE	R/W ENABLE	R/W ENABLE
1	ON	OFF	R/W ENABLE	R/W ENABLE	R/W DISABLE	R ONLY	R ONLY	R ONLY
2	OFF	ON	R/W ENABLE	R ONLY	R/W DISABLE	R ONLY	R ONLY	R ONLY
3	ON	ON	R ONLY	R ONLY	R/W DISABLE	R ONLY	R ONLY	R ONLY

R/W: Read and write (Read and write set values)

R: Read

W: Write



ENABLE: Enabled

DISABLE: Disabled

ONLY: Only the indicated operation is enabled.

Writing on non-volatile memory

After downloading the changed setting data using SFC, save the setting data to MangeW Two-wire PLUS non-volatile memory in approx. 30 seconds. Therefore, do not turn the power off during the operation.

If you want to save the data immediately, press the  key and  key, then the data will be written forcibly to non-volatile memory.

Changing communication method

Two wired magnetic flowmeter has the following 4 communication methods:

- SFN.A... SFC communication (Analog)
- SFN.D... SFC communication (Digital)
- HART... HART communication
- NONE... not using any communication function

~Note *SFC communication (Digital) indicates Enhanced DE communication of Honeywell Co.*

For SFC communication, select “SFN.A”.

To change the communication method, operate using the touch keys. From the data setting screen “COM SELECT” of “OPERATOR'S MODE”, it is required to set the communication method to SFN.A. (Figure 6-4)

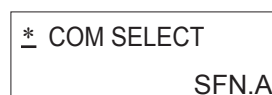

Figure 6-4 Data setting screen

6-2 : Configuration using SFC communicator

Outline of this chapter

This chapter presents how to operate the SFC.

The description proceeds in the following order:

6-2-1: Before communicating using the SFC

Describes the basic operation method.

6-2-2: Setting using SFC communication (1) - setting using key assigned functions

Describes the basic function and setting method.

Describes communication start, range setting, damping constant setting, auto zero point adjustment etc. These can be set by using the key assigned functions (Functions that are directly assigned to each of the SFC keys, refer to next page).

6-2-3: Setting using SFC communication (2) - setting using CONFIG functions

Describes the detailed setting.

Describes the advanced setting for MagneW, screen display, converter information, pulse output/ contact output switching, high low alarm value, burnout direction etc. These can be set by using CONFIG function (entered by

pressing the  key, refer to page 6-16).

6-2-1: Before communicating using the SFC

What can be done using the SFC

Introduction

It is possible to communicate with the converter, read data or change settings using the SFC. The functions available with the SFC include functions directly assigned to the respective keys and CONFIG functions that are entered by pressing the CONF key.

CAUTION

- Be sure to use the SFC with software version 7.0 or newer. Using earlier versions may fail to operate the SFC correctly.

Key assigned functions

The following are the functions directly assigned to the SFC keys.

ID/DE READ:	Starts communication.....	6-19
	Enter the TAG No.	6-21
DAMP:	Sets and changes a damping time constant	6-23
UNITS:	Sets engineering units	6-24
URV:	Sets the output range and correction coefficient	6-26
OUTPUT:	Displays transmitting output	6-27
	Loop check of output signal	6-28
CORRECT:	Making zero adjustment.....	6-29
INPUT:	Displays flow measured value	6-30
STAT:	Displays self-diagnostics result of the converter	6-31
SW VER:	Displays the software version	6-35
PRINT:	Prints out internal data of the converter	6-36
ACT PRINT:	Continuously prints out response result	6-39
A-DE:	Switches between digital and analog outputs.....	6-41

CONFIG functions

The CONFIG functions that are entered by pressing the  key include the following 17 sub-functions.

UNIT KEY:	Select unit system and setting of specific gravity.....	6-42
CUT OFF:	Sets and changes low flow	6-44
DISP:	Changes flow rate display.....	6-46
EX (mA):	Sets detector constant	6-48
TYPE:	Sets detector type.....	6-50
DIAMETER:	Sets detector diameter.....	6-52
ALARM CONFIG:	Sets high alarm and low alarm values	6-54
F/S SETUP:	Sets fail-safe direction	6-56
DIGITAL I/O:	Select pulse output and contact output	6-60
	Sets contact output status.....	6-62
DI/DO CHECK:	Output check of contact output	6-64
CORRECT DAC:	Analog output calibration	6-66
GAIN CAL:	Gain calibration	6-68
SHIP DATA RECOV:	Resets internal data setting to factory setting	6-70
READ TOTAL:	Reads flow rate counter value.....	6-71
PULSE OUTPUT:	Checks pulse output value	6-72
PULSE CONFIGURE:	Sets pulse scale and pulse scale unit	6-74
	Sets pulse width	6-76
	Sets dropout	6-78
RESET TOTALIZE:	Resets flow rate counter.....	6-80

 **CAUTION**

- Do not operate the following screen from the calibration menu. Operating this screen will erase all data entered in the electromagnetic flow meter.

CALIBRATION MENU
INIT DATA RECOV ?

SFCM00008003D

Hierarchical structure of CONFIG functions

Hierarchic structure chart

Each functions of SFC form a hierarchical structure. Before setting using the SFC, check the positions of the respective sub-functions with the supplied hierarchical structure chart.

The SFC screen displays only two lines, and so if it is not clear which hierarchy is shown, see the hierarchy chart on page 6-17.

SFC hierarchical structure chart

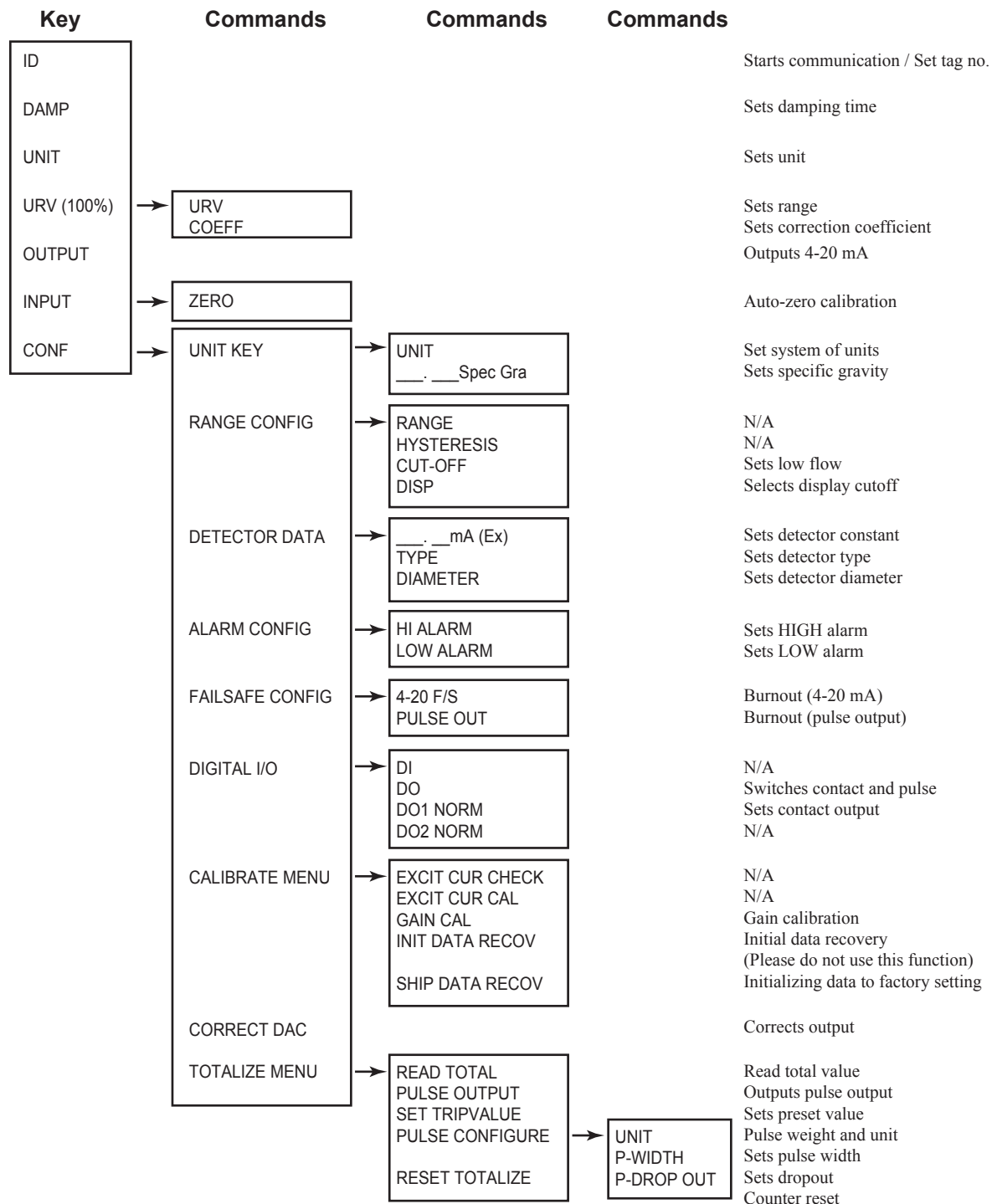

Example of a key sequence

Rules of interaction with screen

- *1: ENTER key to answer "Yes" to a question on the screen and move to one level lower in the hierarchy.
- *2: CLR key to answer "No" to a question on the screen and move to one level higher in the hierarchy.
- *3: NEXT/PREV key to select a different function in the same hierarchy.
- *4: MENU ITEM key to select a different item in the same hierarchy and with the same function.
- *5: SHIFT + CLR keys to exit the CONFIG functions from any level.

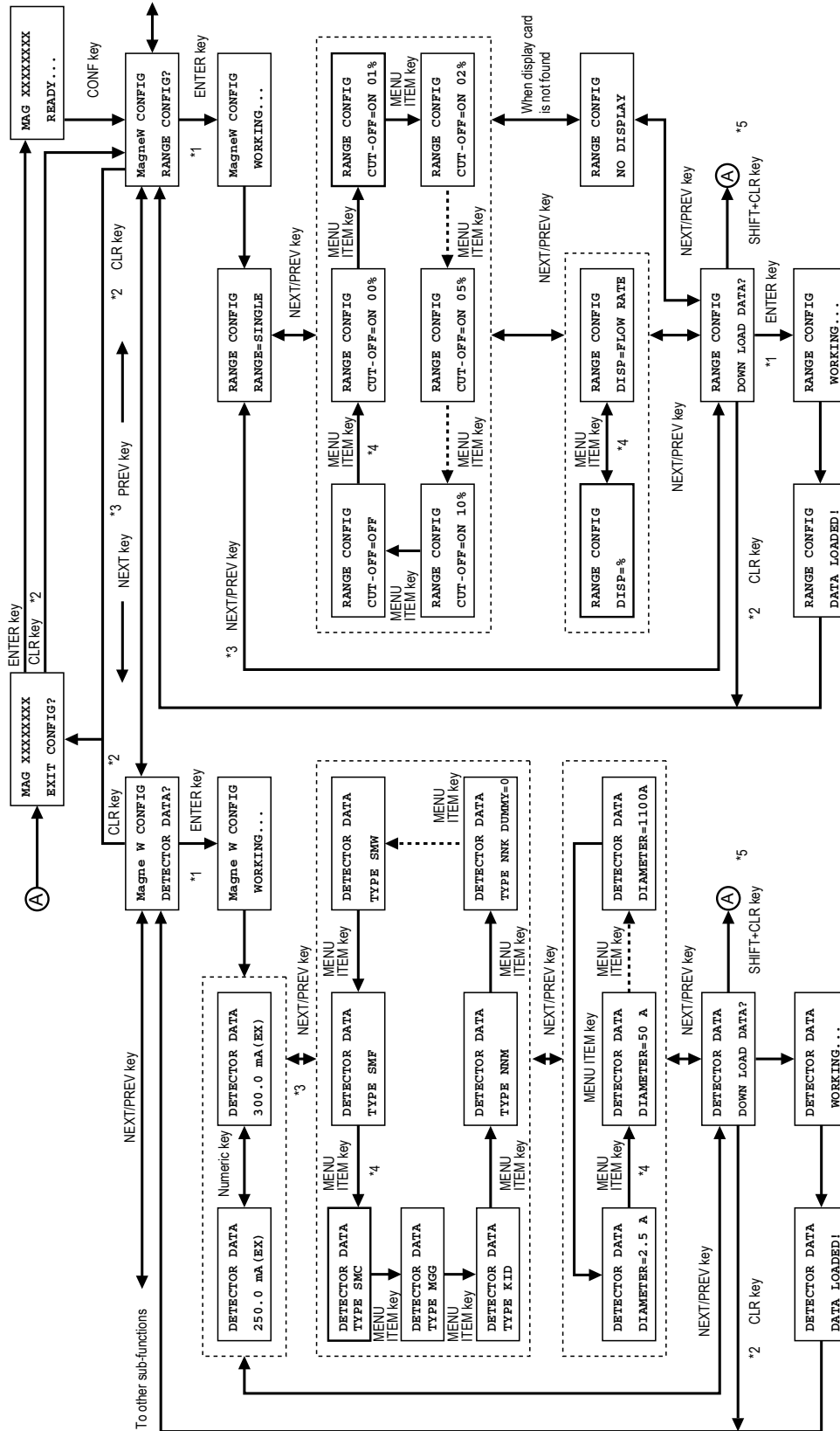

6-2-2: Setting using SFC communication (1) - setting using key assigned functions

Starting communication: ID/DE READ key









⚠ CAUTION

Before starting communication between the SFC in a system with analog output and the converter, be sure to change the control loop to “manual control”. This is to prevent fluctuation in analog output of the converter, which is caused by starting the SFC and communicating with the converter, from directly affecting the control loop.

Procedure

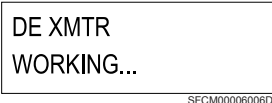
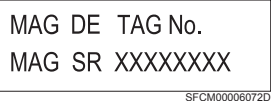
Use the following procedure to start the SFC. The key operations of the SFC and display of the display window slightly vary depending on whether the system has digital output or analog output.

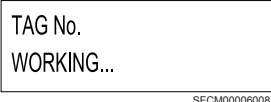
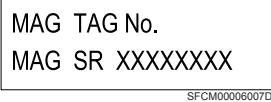
Step	Procedure	SFC screen
1	Check that the converter has been started. If not started yet, start the converter with reference to “Chapter 4 : Operation” in this manual.	
2	Make sure the wiring between the converter signal line and SFC is correct.	
3	<p>Turn the SFC on.</p> <p>Result:</p> <ul style="list-style-type: none"> The SFC executes self-diagnostics and the screen as shown on the right appears. <div style="border: 1px solid black; padding: 5px; margin-top: 10px;"> <p style="text-align: center;">⚠ CAUTION</p> <p>This display is intended to prompt the user to take appropriate action to prevent fluctuation in the output of the converter caused by the SFC communicating with the converter from directly affecting the control loop. Before pressing the  key, take appropriate action to change the control device to “manual”. A system with analog output requires special care.</p> </div>	<div style="border: 1px solid black; padding: 5px; margin-bottom: 10px; text-align: center;"> SELF CHECK... <small>SFCM00006004D</small> </div> <div style="border: 1px solid black; padding: 5px; text-align: center;"> LOOP IN MANUAL ? PRESS ID <small>SFCM00006005D</small> </div>

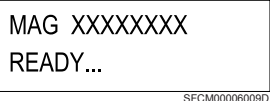
Step	Key	Procedure
4	 	<ul style="list-style-type: none"> In the case of a system with digital output, press the  key here.  <small>SFCM00006002D</small> Press the  key.  <small>SFCM00006006D</small>  <small>SFCM00006007D</small> <ul style="list-style-type: none"> In the case of a system with analog output, press the  key here.  <small>SFCM00006008</small>  <small>SFCM00006007D</small> <p>Result and branch:</p> <ul style="list-style-type: none"> The following screen appears and a communication between the SFC and converter can be started. Go to step 6. If the TAG No. has not been entered in the converter, the TAG No. displays as XXXXXXXX. Go to step 5.
5		<p>Here, TAG No. can be entered. For a detailed procedure, see “Entering TAG No.: ID key” on page 6-21.</p> <p>If there is no need to enter a TAG No., go to step 6.</p>
6		<p>Press the  key. The following screen appears.</p> <p>This screen is the basic standby screen. When starting operation, confirm that the following screen has appeared.</p>  <small>SFCM00006009D</small>











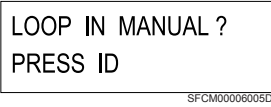









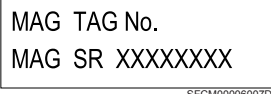

Entering TAG No.: ID key



Introduction

To facilitate concentrated control by the control system of the control loop over two or more converters, a TAG No. can be assigned to each converter. Up to 8 alphanumeric characters can be entered as a TAG No.

Procedure

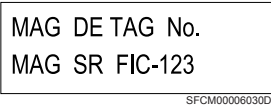
Use the following procedure to enter TAG No.

Step	Key	Procedure	SFC screen
1		Check that the display of the SFC appears as shown to the right. If a different display appears, refer to “Setting using SFC communication (1) - setting using key assigned functions” on page 6-19.	
2	  +   +  keys.	Carry out the following operation according to the output format of the SFC used. <ul style="list-style-type: none"> For SFN.A analog output communication method, press the  key. For SFN.D digital output communication method, press the  +  keys. 	 (For SFN.A)  (For SFN.D)
3	    	-Use the  key and numeric keys to enter up to 8 alphanumeric characters for a TAG No. ~Note <ul style="list-style-type: none"> On this screen, the  key and numeric keys and  key and  key are active. Even if other keys are pressed, there will be no response. To enter letters, press the  key and display the “□” cursor. To enter numerals, press the  key again and display “_” cursor. 	

Step	Key	Procedure	SFC screen
4		<p>Press the  key.</p> <p>Result:</p> <ul style="list-style-type: none"> After “WORKING...” appears on the screen, the TAG No. just entered appears. Hereafter, this name becomes the TAG No. of this converter. 	<div style="border: 1px solid black; padding: 5px; margin-bottom: 10px;"> MAG DE TAG No. MAG SR FIC-123 <small>*****</small> </div> <p style="text-align: center;">(For SFN.A)</p> <div style="border: 1px solid black; padding: 5px; margin-bottom: 10px;"> MAG DE TAG No. MAG SR FIC-123 <small>*****</small> </div> <p style="text-align: center;">(For SFN.D)</p>







Setting/changing damping time constant: DAMP key

Introduction

Damping time constant is a response time of the primary delay (65.2% response) for a step response of the flow rate. When the output fluctuations are large increase the damping. A large damping value stabilizes the output but lowers the response performance. The damping time constant can be set to 0.5 up to 199.9 sec. using numeric keys.

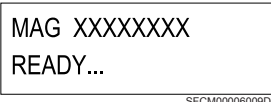
Procedure

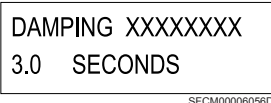
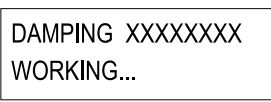
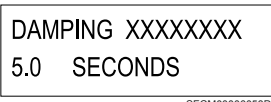
Use the following procedure to set the damping time constant.

Step	Key	Procedure	SFC screen
1		Confirm that the SFC is set to "READY". If it is not, press the  key to set it to "READY".	
2		Press the  key. Result: • The currently set damping time constant appears as shown here.	
3		Use numeric keys to set the damping time constant. (Input range: 0.5 to 199.9) Result: • The changed setting is written into the database of the converter and displayed on the screen.	 
4		Press the  key to return to the screen in step 1.	

Setting engineering units: UNITS key

Introduction

The instantaneous flow rate value measured by the converter can be set so that it is displayed in engineering units according to the control process used.

This setting is applied to both display screens of the display panel of the converter and the SFC.





The engineering units that can be set are as follows.







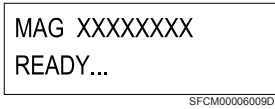

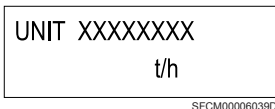







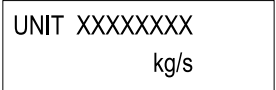

Volume flow rate units	Mass flow rate units
m ³ /h, GPH, l/h, cc/h, m ³ /min, GPM, l/min, cm ³ /min, m ³ /day, GPD, kGPD, BPD, m ³ /s GPH=gals/hr, GPM=gals/min, GPD=gals/day, kGPD=1000XGPD, BPD=barrels/day	kg/h, lb/h, kg/min, lb/min, kg/s, lb/s, t/s, t/min, t/s, g/h, g/min, g/s

When mass flow rate units are set, the specific gravity can be set.

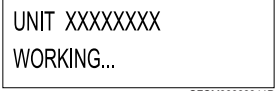
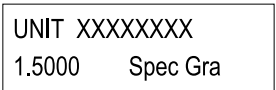
Procedure

Use the following procedure to set engineering units.

Step	Key	Procedure	SFC screen
1		Confirm that the SFC is set to "READY". If it is not, press the  key to set it to "READY"	
2		Press the  key. Result: <ul style="list-style-type: none"> The currently set engineering unit appears as shown on the right. 	

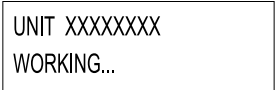
Step	Key	Procedure	SFC screen
3	 OR   	<p>Use the  key and  key to display the engineering unit to be set.</p> <p>Pressing the  key instead of the  key can also change the screen.</p> <p>Branch:</p> <ul style="list-style-type: none"> To exit this function, press the  key. 	 <small>SFCM00006040D</small>
4	 	<p>Press the  key.</p> <p>Result and branch:</p> <ul style="list-style-type: none"> The engineering unit to be set is written into the database. Setting is completed when the screen returns to step 2. Press the  key to return to step 1. When the engineering unit to be set is mass flow rate, the setting content is written into the database. Go to step 5. 	 <small>SFCM00006041D</small>
5		Press numeric keys to set specific gravity.	 <small>SFCM00006042D</small>
6	 	<p>Press the  key. When the screen as shown on the right appears, press the  key once again. The setting is completed when the screen returns to the screen as in step 2. Press the  key to return to step 1.</p>	 <small>SFCM00006041D</small>

Setting output range and correction coefficient: URV key

Introduction

The output range of the converter is set at the factory according to the ordered specifications. This setting can be displayed on the screen of the SFC or changed.

Definition

- URV (Upper Range Value) refers to a measured value of flow rate when the output of the converter becomes 100% (20 mA DC in the case of analog output) and means an upper range value of the output range of the converter. Pressing the



key displays the set URV (e.g., 10,000 m³/h) on the screen. URV setting range is 0.3 to 10 m/s in flow rate conversion.

Procedure







Use the following procedure to display or change the set output range.

Step	Key	Procedure	SFC screen
1		Make sure that the SFC is set to "READY". If it is not, press the key to set it to "READY".	 <small>SFCM00006036D</small>
2		Press the key. Result: • The set URV appears as shown to the right.	 <small>SFCM00006036D</small>
3		Use numeric keys and key to enter the URV to be set.	 <small>SFCM00006037D</small>
4		Press the key.	 <small>SFCM00006037D</small>
5		When pressing the key, correction coefficient will be set. Set if necessary.	 <small>SFCM00006074D</small>
6		Press the key.	
7		Press the key to return to step 1.	

Displaying transmitting output: OUTPUT key

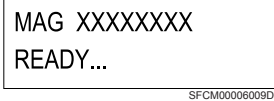
Procedure

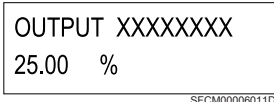
Use the following procedure to be able to read the current output value from the converter to the SFC.

Step	Key	Procedure	SFC screen
1		Make sure that the SFC is set to “READY”. If it is not, press the  key to set it to “READY”.	
2		Press the  key. Result: • The current output value appears as shown on the right.	
3		After checking the current output value, press the  key to return to step 1.	

Loop check of output signal

Introduction









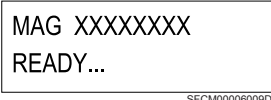

The converter is provided with a function of a constant current generator. As the magnitude of a current that can be generated, an arbitrary value of 0 to 100% of the flow rate signal can be set. A loop check can be made using this function.

Used when

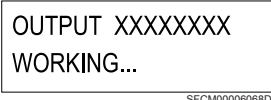
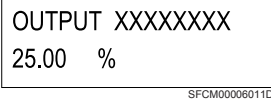
Use this function to check the connection status or the operation of devices connected to the converter in the measured loop.

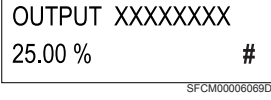
Operation



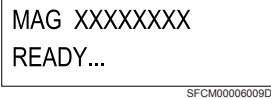







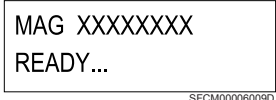

This function is operated from the SFC. Use the following procedure.

Step	Key	Procedure	SFC screen
1		Make sure that the SFC is set to "READY". If a screen other than the one as shown on the right is displayed, press the  key.	
2		Press the  key.	
3		Press numeric keys to enter the value of a signal current to be generated in percentage. The example to the right shows a case where a current equivalent to 25% flow rate is generated.	
4		Press the  key. This generates a constant current output from the converter. A "#" mark is displayed on the screen during the output.	
5	 	To cancel the constant current output, press  and then press the  key. When the constant current output is canceled, the "#" mark on the screen disappears. Be sure to perform this operation at the end of the loop check. However, even if the instrument is left without performing this operation, the current output is automatically canceled after 10 minutes.	

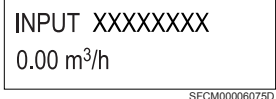
Making zero adjustment: CORRECT key

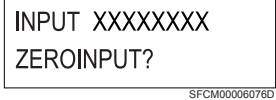
Use the following procedure to do the auto zero adjustment from the SFC.

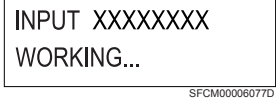
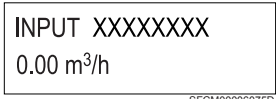

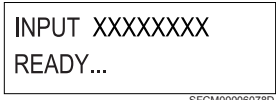





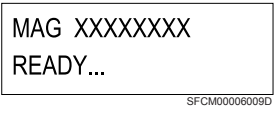

When adjusting auto zero point, stop and make static the fluid in the flow meter.

Step	Key	Procedure	SFC screen
1		Make sure that the SFC is set to "READY". If a screen other than the one here to the right is displayed, press the  key.	
2	 	Press the  key, and then press the  key, Result: The actual measured value appears as shown on the right.	
3		Press the  key. 'Zero INPUT?' will be displayed. Confirm that the actual flow rate equals to zero.	
4		After checking the flow rate, press the  key. Result: Auto zero point adjustment is initiated. It takes approx. 2 min. When the screen returns to the previous screen, auto zero adjustment is completed.	 
5		Press the  key to return to at step 1.	

Displaying flow rate measured value: INPUT key

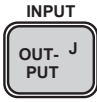
Procedure

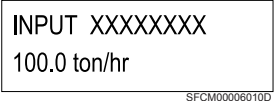
Use the following procedure to be able to read the instantaneous flow rate value measured by the converter from the SFC.

Step	Key	Procedure	SFC screen
1		Make sure that the SFC is set to "READY". If it is not, press the  key to set it to "READY".	
2		Press the  key.	
3		Press the  key. Result: • The instantaneous flow rate value appears as shown on the right.	
4		After checking the instantaneous flow rate value, press the  key to return to at step 1.	







Displaying self-diagnostics result: STAT key

Introduction

It is possible to display the self-diagnostics results of the converter sequentially from the SFC. This key is useful when used in combination with Action printout (page 6-39).

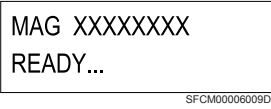
Procedure

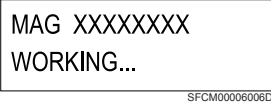
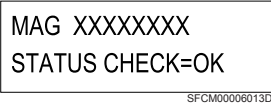
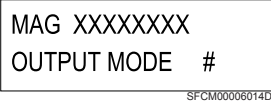
Use the following procedure to be able to display the self-diagnostics results.

Step	Key	Procedure	SFC screen
1		Make sure that the SFC is set to "READY". If it is not, press the  key to set it to "READY"	
2		Press the  key. Result: <ul style="list-style-type: none"> When no error has occurred, the message shown here to the right appears. If a minor fault has occurred, "#" appears at the end of the bottom line of the SFC display window. 	  
3		After checking the self-diagnostics results, press the  key to return to step 1.	

Error messages and remedial action

Troubleshooting

Whenever problem occurs while the electromagnetic flow meter is in operation, use



the  key of the SFC to read the error message and self-diagnostics result (see previous page) and take action according to the table below.

Stopping converter

If an error message with bold letter in the table below appears, turn OFF the power to the converter to stop the electromagnetic flow meter.

In case of critical failure, burnout function (see page 6-56) and high/low alarm (see page 6-54) will operate.

No.	Error message	Checkpoint and action
1	BAD CONFIG DATA	<ul style="list-style-type: none"> • Configuration data is incorrect. • Check the setting with the display function of each setting or configuration printout.
2	CORRECTS RESET	<ul style="list-style-type: none"> • Re-correction is required to keep precision. • Set the CONFIG data. • Perform correction and zero point adjustment.
3	ENTRY > SENS RNG	<ul style="list-style-type: none"> • The flow rate measured value may exceed the upper range value. • Reset the output range.
4	ENTRY HEIGHT	<ul style="list-style-type: none"> • The set value of constant current generation exceeds the allowable range. • Reset the set value.
5	EXCIT CHECK MODE	<ul style="list-style-type: none"> • The excitation current is being checked. <p>~Note</p> <ul style="list-style-type: none"> • <i>The electromagnetic flow meter cannot set the flow direction of the excitation current. The flow direction is fixed at either "X->Y" or "Y->X" independently of the flow direction specified by the SFC.</i>
6	FAILED COMM CHK	<ul style="list-style-type: none"> • Communication failure with the electromagnetic flow meter. • Check the SFC and communication loop.
7	HI RES / LO VOLT	<ul style="list-style-type: none"> • The load resistance of the loop is too large or the power supply voltage is too low.









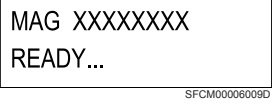

No.	Error message	Checkpoint and action
8	ILLEGAL RESPONSE	<ul style="list-style-type: none"> Abnormal communication with the electromagnetic flowmeter. Check the communication cable and load resistance.
9	IN LOCAL MODE	<ul style="list-style-type: none"> The converter is currently being operated from the display panel. At this time, it is not possible to communicate from the SFC.
10	IN OUTPUT MODE	<ul style="list-style-type: none"> The converter is in constant current generation mode. Press the  key and then press the  key to cancel the mode.
11	INVALID DATABASE	<ul style="list-style-type: none"> A critical failure. Stop the electromagnetic flow meter. This error occurs because the converter database has not been set correctly when the power to the converter is turned ON. Re-enter the CONF data.
12	INVALID REQUEST	<ul style="list-style-type: none"> The requested function cannot be performed. Check the operation procedure of the SFC and press the  key.
13	LOCAL MODE	<ul style="list-style-type: none"> The converter is being operated. At this time, it is not possible to communicate from the SFC.
14	NO XMTR.RESPONSE	<ul style="list-style-type: none"> There is no response from the electromagnetic flow meter. Check the communication cable and measurement loop.
15	NVM FAULT	<ul style="list-style-type: none"> A critical failure. Stop the electromagnetic flow meter. The non-volatile memory of the converter is abnormal. Turn OFF the power and then turn it ON again and check the operation. If the same message still appears after taking the action above, contact your local Yamatake representative.
16	PRINTER FAIL!	<ul style="list-style-type: none"> The printer does not operate.

No.	Error message	Checkpoint and action
17	RAM FAULT	<ul style="list-style-type: none"> • A critical failure. Stop the electromagnetic flow meter. • The RAM of the converter is abnormal. Turn OFF the power and then turn it ON again and check the operation. • If the same message still appears after taking the action above, contact your local Yamatake representative.
18	ROM FAULT	<ul style="list-style-type: none"> • A critical failure. Stop the electromagnetic flow meter. • The ROM of the converter is abnormal. Turn OFF the power and then turn it ON again and check the operation. • If the same message still appears after taking the action above, contact your local Yamatake representative.
19	SFC FAULT	<ul style="list-style-type: none"> • An SFC error. • Replace the SFC.
20	SPAN OVER ERROR	<ul style="list-style-type: none"> • As a result of setting the span, the maximum measurable flow rate has exceeded 12 m/s. • Check the span, diameter or type of the detector.
21	>RANGE	<ul style="list-style-type: none"> • The calculation result of the SFC has exceeded the display range. • Restart the SFC. • The SFC battery is running low.
22	:	<ul style="list-style-type: none"> • Charge the SFC. • A minor fault.
23	#	<ul style="list-style-type: none"> • Press the  key and check the self-diagnostics result of the SFC.

Displaying software version: SW VER key

Procedure

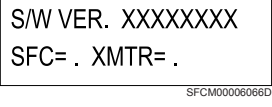
Use the following procedure to confirm the software version of the SFC and the converter connected to the SFC used.

Step	Key	Procedure	SFC screen
1		Make sure that the SFC is set to "READY". If it is not, press the  key to set it to "READY".	
2		Press the  key.	
3		Press the  (SW VER) key. Result: - The software version is displayed.	
4		After confirming the software version, press the  key to return to the screen in step 1.	

Data printing

Introduction

To carry out correct flow rate measurement, it is important to check the internal setting or response from the converter before starting to operate the converter or while the converter is in operation. At this time, it is convenient if you use the SFC with a printer to communicate with the converter and print out data. The SFC with a printer has two types of printing functions as defined below.

Definition

Configuration printout (data printout):

The SFC printer can print out internal data of the converter such as the converter tag number (TAG No.), damping time constant, low flow cutoff. This printing function is called “configuration printout” or “data printout”.



Action printout (continuous printout):

The SFC is provided with a function that continuously prints out results of responses to key operations of the SFC from the converter. This printing function is called “action printout” or “continuous printout”.

Printer

The optional SFC printer is a 24 characters/line thermal printer. When the power switch to the SFC is turned ON, the printer automatically starts to move and stops after moving back-and-forth once. At this time, the recording paper will advance a little (approximately 5 mm).

Advancing recording paper

To advance recording paper, press  + .

The screen will display “PRINTER FEED” and the recording paper is advanced by one line. While this prompt is displayed, the recording paper is advanced by one line

every time the  key is pressed.

To cancel the feed function, press the  key.

Feeding recording paper

When the printer is running short of recording paper, feed the paper roll compartment with a paper roll. For a detailed procedure, see the SFC User's Manual (CM2-SFC100-2001).









Printing internal data: PRINT key

Used when

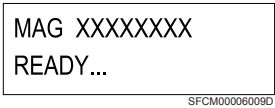
Configuration printout (data printout) is used to print out internal data of the converter such as a damping time constant, low flow cutoff, etc.

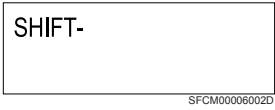
Procedure

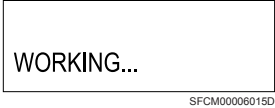
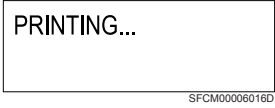
Use the following procedure to carry out configuration printout.

Step	Key	Procedure	SFC screen
1		Start communication between the SFC and converter. For a detailed procedure, see “Starting communication: ID/DE READ key” on page 6-19.	
2		Make sure that the SFC is set to “READY”. If it is not, press the  key set it to “READY”	
3		Press the  key.	
4		Press the  key. Result: • Configuration printout starts.	 
5		When printing is completed, press the  key to return step 2.	

Printing example

The following shows an example of an actual configuration printout accompanied by line-by-line descriptions.

Printing example	Meaning
'02-01-01 00:00	Time when printed
TAG No. XXXXXXXXX	Tag no.
Detector	Detector information
DIA : 50 A	Diameter
TYPE : MGG	Type
EX : 300.0 mA	Detector constant
RANGE : SINGLE	Range
ANA/DE : ANALOG XMTR	Communication mode
D1 : D1 NOT USED	Setting of contact input
DO : DO NOT USED	Setting of contact output
SW VER : 3.1	Software version
DAMP : 3.00	Damping constant
SPAN1 : 70.69 m3	Span
GRAVITY : 1.0000	Specific gravity
COEFF : 1.0000	Correction coefficient
LOFCUT : ON 0.6 %	Low flow cutoff
F/S I : UP	Burnout (4-20 mA output)
DO : OPEN	Burnout (Contact output)
P : HOLD	Burnout (Pulse output)
PULSE	Pulse information
CONF : ADD	Setting of built-in counter
RESET : 0000000000	Reset value
WEIGHT : 110 cc/p	Pulse scale
WIDTH : DUTY 50%	Pulse width
DROP : 0.5%	Dropout value
INPUT : 70.69 m3	Input value
OUTPUT : 100.02 %	Output value
STATUS CHECK= OK	Status











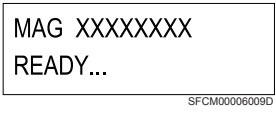

Continuously printing response result: ACT PRINT key

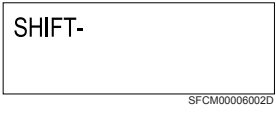



Used when

Action printout (continuous printout) is used to continuously print out the results of responses from the converter to key operations from the SFC and to keep the data.

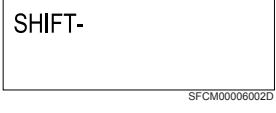
Procedure

Use the following procedure to carry out action printout.



Step	Key	Procedure	SFC screen
1		Start communication between the SFC and converter. For the detailed procedure, see “Starting communication: ID/DE READ key” on page 6-19.	
2		Make sure that the SFC is set to “READY” If it is not, press the  key to set it to “READY.”	
3		Press the  key.	
4		Press the  (ACT PR) key.	
5		Press the  key. Result: Action printout starts by printing: * ACTION PRINT * START TAG No. FIC-123 '02-06-05 15:30 Hereafter, the operation content and results of response from the converter are printed out every time the key is operated.	
6		Press the  key to stop the action printout operation.	

Step	Key	Procedure	SFC screen
7		Press the  key.	<div style="border: 1px solid black; padding: 5px; width: fit-content;">MAG XXXXXXXX ACTION PRINT ? <small>SFCM00006017D</small></div>
8		Press the  key. Result: The action printout operation ends by printing: * ACTION PRINT * END Then, the screen returns to step 2.	

Printing example



An example of an action printout corresponding to actual key operation will be explained.

Key operation

 +  (ACT PR) +  keys

 key

 key

 +  (ACT PR) +  keys

Printing example of corresponding action printout

```

* ACTION PRINT * START
TAG. No.  FIC-123
□        '02-06-05 15:35

DAMP□    XXXXXXXX
3.0□    S

DAMPING□ XXXXXXXX
4.0□    S

* ACTION PRINT * END
        
```

Switching between digital output and analog output: A ↔ DE key

Introduction











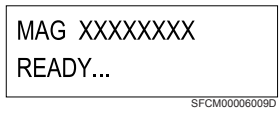

Allows the signal line output of the converter to be switched between analog and digital. Communication method can be displayed on the two wired magnetic flowmeter main body's data setting screen. However, analog communication will be displayed as an SFN.A, and digital as an SFN.D.

CAUTION

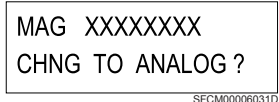
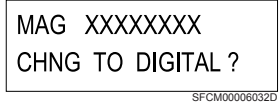
Before switching the output, adjust the higher devices according to the output (analog or digital) of the converter. This is to prevent the output coming from the converter from affecting the control loop.

Procedure

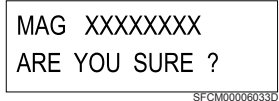

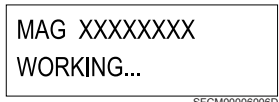
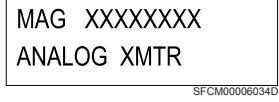
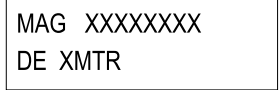









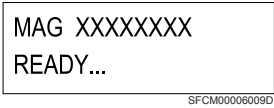

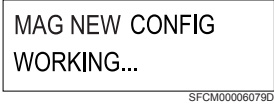
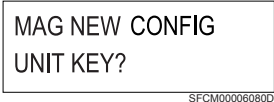

Use the following procedure to change the output of the converter.









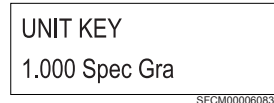



Step	Key	Procedure	SFC screen
1		Confirm that the SFC is set to "READY". If it is not, press the  key to set it to "READY".	
2	 	Press the  key, and then press the  key. Result: <ul style="list-style-type: none"> If digital output is currently set, the screen to the upper right appears. If analog output is currently set, the screen do shown on the lower right appears. 	 (For digital output)  (For analog output)
3		Press the  key. <ul style="list-style-type: none"> To stop switching of the output format, press the  key. The screen at step 1 appears. 	
4		Press the  key again, and the communication will be switched. Automatically, the screen returns to step 1.	  or 

6-2-3: Setting using SFC communication (2) - setting using CONFIG functions

Selecting unit system and setting specific gravity [UNIT KEY] function

It is possible to select unit system (Mass flow rate and volume flow rate) which is set by two wired magnetic flowmeter converter, and set the specific value (in case of selecting mass flow rate for system units). Use the following procedure to select unit system and to set specific gravity.

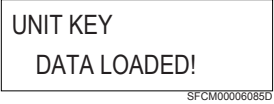
Step	Key	Procedure	SFC screen
1		Confirm that the SFC is set to "READY". If it is not, press the  key to set it to "READY".	
2		Press the  key to access the CONFIG functions. Confirm that the screen on the right appears.	 
3	 	Press the  key. The screen, which system of units can be selected, appears as shown to the right. Mass flow rate = MASS FLOW Volume flow rate = VOLUME FLOW Press the  key, and select MASS FLOW or VOLUME FLOW.	
4		Press the  key. The screen as shown on the right appears and the changed setting is saved to the SFC.	
5	 OR 	Only when MASS FLOW is selected, a screen for setting the specific gravity appears. Press the  key or  key to show this screen. Press numeric keys to set specific gravity. Available range of specific gravity is from 0.1000 to 5.9999.	

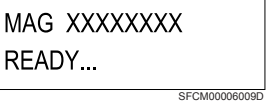
Step	Key	Procedure	SFC screen
6		Press the  key. Changed setting is saved to SFC.	
7	 OR 	Press the  key or  key to show this screen.	
8		Press the  key. The changed setting is written into the database of the converter and the setting is completed.	
9		Press the  key, and return to the screen as in step 1.	

Setting or changing low flow cutoff: [CUT-OFF] function

Introduction

When a fluid in the detector is flowing extremely slowly, the converter judges that the fluid is stationary and outputs a signal (4 mA DC in case of analog output) equivalent to a flow rate of zero. The value, which becomes the threshold of this judgment is called “low flow cutoff”.











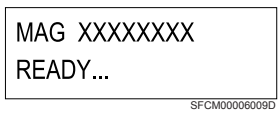

The low flow cutoff is set using a percentage over the upper range value of the flow rate measurement range set by the URV.

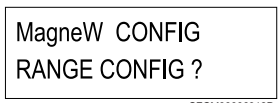

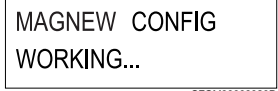





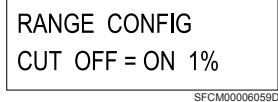



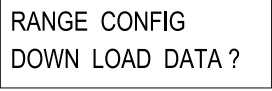

⚠ CAUTION

The low flow cutoff is a factor of extreme importance that affects the operation of the entire control process. Define the range to be controlled and start the setting carefully.

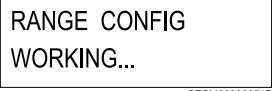
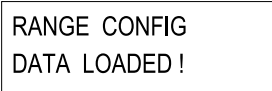
Procedure

Use the following procedure to set low flow cutoff.

Step	Key	Procedure	SFC screen
1		Confirm that the SFC is set to “READY”. If it is not, press the  key to set it to “READY”.	
2		Press the  key to access the CONFIG functions.	
3		Press the  key.	
4		Press the  key.	
5	 	Pressing the  key changes a numeric value to the right of CUT OFF=ON displayed on the screen from 0% up to 10% in 1 point increments. Continuing to press the  key further sets CUT OFF=OFF and displays CUT OFF=ON 0% again. Display the low flow cutoff to be set in the range of 1- to 10% on the screen.	

Step	Key	Procedure	SFC screen
6		Press the  key. Result: <ul style="list-style-type: none"> The screen as shown on the right appears and the set low flow cutoff is confirmed. 	 <small>SFCM00006051D</small>
7	 OR 	Press the  key or  key to show this screen (DOWN LOAD).	 <small>SFCM00006053D</small>
8		Press the  key. Result: <ul style="list-style-type: none"> The screen as shown on the right appears and the changed setting is written into the database of the converter. The screen returns to step 2. <p>~Note</p> <ul style="list-style-type: none"> In step 5, if you try to set displaying “CUT OFF = OFF” or “CUT OFF = ON 00%”, “INVALID REQUEST” will appear on the screen. Converter will reject the database to be written in. 	 <small>SFCM00006054D</small>  <small>SFCM00006055D</small>
9	 + 	To exit this setting function, press the  +  keys.	
10		Press the  key. Result: <ul style="list-style-type: none"> Exiting the low flow cutoff setting function, the screen returns to the screen in step 1. 	

Changing flow rate display: [DISP] function













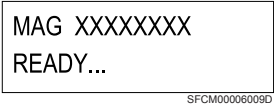

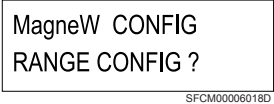
Introduction

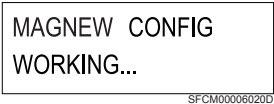



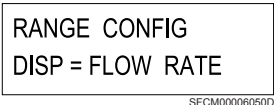

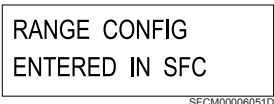

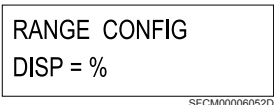



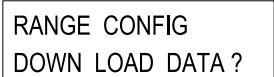

It is possible to set whether an instantaneous flow rate displayed on the display panel of the converter should be expressed as real flow rate or percentage.

Percent display refers to a percentage (%) over the maximum flow rate set by the URV.

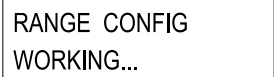
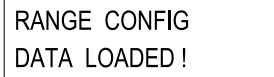
Procedure

Use the following procedure to set or change flow rate display.

Step	Key	Procedure	SFC screen
1		Confirm the SFC is set to "READY". If it is not, press the  key to set it to "READY".	
2		Press the  key to access the CONFIG functions.	
3		Press the  key.	
4	 or 	Press the  key or  key to display this screen.	
5		Press the [ENTER] key. Result: • The screen as shown on the right appears and the set flow rate display is confirmed.	
6		Pressing the  key displays DISP=%, DISP=FLOW RATE and DISP=TOTAL by turns. Display the screen that you want to set.	

Step	Key	Procedure	SFC screen
7	DE CONF. 	Press the  key. Result: <ul style="list-style-type: none"> The screen as shown on the right appears and the set flow rate display is confirmed. 	 <small>SFCM00006051D</small>
8	 OR 	Press the  key or  key to show this screen (DOWN LOAD).	 <small>SFCM00006053D</small>
9	NON-VOL 	Press the  key. Result: <ul style="list-style-type: none"> The screen to the right appears and the changed setting is written into the database of the converter. The screen returns to step 2. 	 <small>SFCM00006054D</small>  <small>SFCM00006055D</small>
10	 + 	To exit this setting function, press the  +  keys.	
11	NON-VOL 	Press the  key. Result: <ul style="list-style-type: none"> - Exiting the flow rate display setting function, the screen returns to the screen in step 1. 	

Setting detector constant: [EX(mA)] function

Introduction











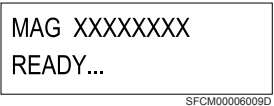

The detector constant of the converter is set at the factory according to the ordered specifications. This constant can be changed.

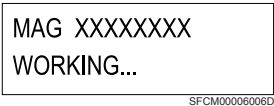
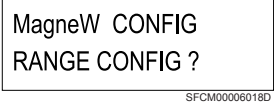







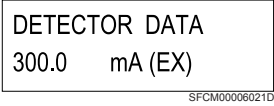
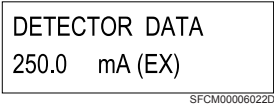



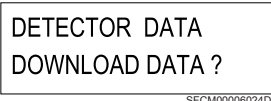

Used when

When a combination between the detector and converter has been changed, the detector constant set by the converter needs to be changed.

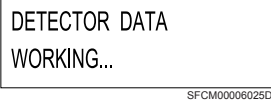
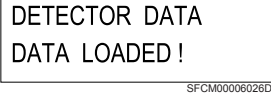
Procedure

Use the following procedure to set detector constant.

Step	Key	Procedure	SFC screen
1		Make sure that the SFC is set to "READY". If it is not, press the  key to set it to "READY".	
2		Press the  key to access the CONFIG functions.	 
3	 or 	Press the  key or  key to display the screen as shown on the right.	
4		Press the  key. Result: • The currently set detector constant appears as shown on the right.	 
5		Press numeric keys to set the detector constant. Setting range is 200 to 699.9.	

Step	Key	Procedure	SFC screen
6		Press the  key. Result: <ul style="list-style-type: none"> The screen as shown on the right appears and the set detector constant is confirmed. 	
7	 or 	Press the  key or  key to display the screen as shown on the right.	
8		Press the  key. Result: <ul style="list-style-type: none"> The screen as shown on the right appears and the changed setting is written into the database of the converter. The screen returns to step 3. 	 
9	 + 	To exit this setting function, press the  +  keys.	
10		Press the  key. Result: <ul style="list-style-type: none"> The screen exits the detector constant setting function and returns to the screen in step 1. 	













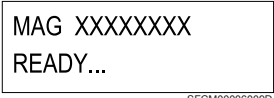

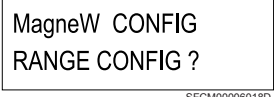

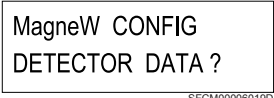

Setting detector type: [TYPE] function

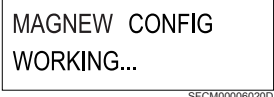











Introduction

The type of the detector of the converter is set at the factory according to the ordered specifications. The settings of this type can be changed. When using two wired magnetic flowmeter, it is necessary to select “MGG” (refer to step 6) for detector type.

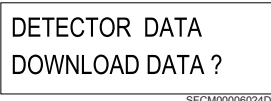
Procedure

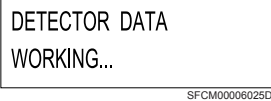
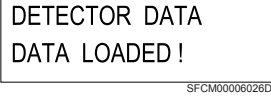
Use the following procedure to set the type of the detector.

Step	Key	Procedure	SFC screen
1		Make sure that the SFC is set to “READY”. If it is not, press the  key to set it to “READY”	
2		Press the  key to access the CONFIG functions.	
3	 or 	Press the  key or  key to display the screen as shown on the right.	
4		Press the  key.	
5	 or 	Press the  key or  key to display the screen as shown on the right.	
6		Pressing the  key changes the sign to the right of TYPE displayed on the screen from MGG → KID → NNM → NNK DUMMY=0... NNK DUMMY=9→SMW→SMF→SMC, sequentially. Display the detector type to be set on the screen.	

Step	Key	Procedure	SFC screen
7		Press the  key. Result: <ul style="list-style-type: none"> The screen as shown on the right appears and the set detector type is confirmed. 	
8	 or 	Press the  key or  key to display the screen (DOWN LOAD) as shown on the right.	
9		Press the  key. Result: <ul style="list-style-type: none"> The screen as shown on the right appears and the changed setting is written into the database of the converter. The screen returns to step 3. 	 
10	 + 	To exit this setting function, press the  +  keys.	
11		Result: <ul style="list-style-type: none"> The screen exits the detector type setting function and returns to step 1. 	

Setting diameter of detector: [DIAMETER=] function

Introduction













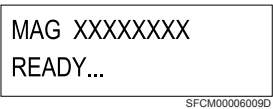





The diameter of the detector of the converter is set at the factory according to the ordered specifications. The setting of this diameter can be changed.









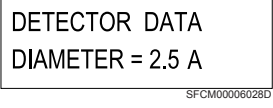



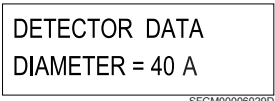



Used when

When only the detector is replaced with one of a different diameter, this function is used to reset the diameter.

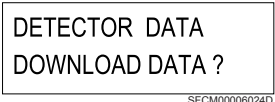
Procedure

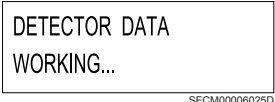
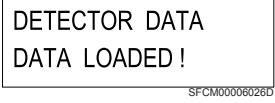
Use the following procedure to set the diameter of the detector.













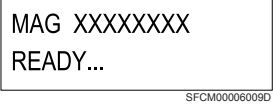



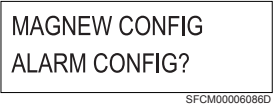

Step	Key	Procedure	SFC screen
1		Confirm that the SFC is set to "READY". If it is not, press the  key to set it to "READY"	
2		Press the  key to access the CONFIG functions.	
3	 OR 	Press the  key or  key to display the screen as shown on at the right.	
4		Press the  key.	
5	 OR 	Press the  key or  key to display the screen as shown on the right.	







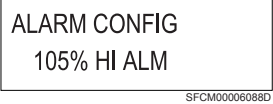

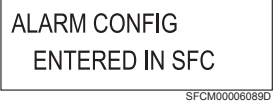







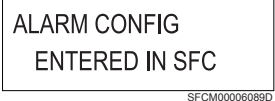

Step	Key	Procedure	SFC screen
6		Pressing the  key changes the numerical value to the right of DIAMETER= shown on the screen from 2.5 mm up to 1100 mm. Range of two wired magnetic flowmeter detector diameter is 2.5 to 200 mm.	
7		Press the  key. Result: <ul style="list-style-type: none"> The screen as shown on the right appears and the set detector type is confirmed. 	
8	 OR 	Press the  key or  key to display the screen (DOWN LOAD) as shown on the right.	
9		Press the  key. Result: <ul style="list-style-type: none"> The screen as shown on the right appears and the changed setting is written into the database of the converter. The screen returns to step 3. 	 
10	 + 	To exit this setting function, press the  +  keys.	
11		Result: <ul style="list-style-type: none"> The screen exits the detector diameter setting function and returns to step 1. 	

Setting high/low alarm values [ALARM CONFIG] function

Use the following procedure to set the high and low alarm values. High and low alarm values can be used only when contact output is selected. (Refer to “Select pulse output / contact output [DIGITAL I/O] function” on page 6-60)

Setting range of the both high and low alarm values are 0 up to 115%. Set the values as to be HI > LO.

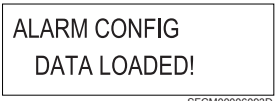
Step	Key	Procedure	SFC screen
1		Confirm that the SFC is set to “READY”. If it is not, press the  key to set it to “READY”	
2	  OR 	Press the  key to access the CONFIG functions. Press the  key or  key to display the screen as shown on the right.	
3	  OR 	Press the  key and press the  key or  key to display the screen as shown on the right. Actual high alarm value appears.	
4		Press numeric keys and enter the high alarm value to be set.	
5		Press the  key. The changed setting is saved to the SFC.	

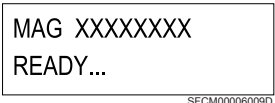
Step	Key	Procedure	SFC screen
6	 or 	Continue to set the low alarm value. Press the  key or  key to display this screen. Actual low alarm value appears.	
7		Press numeric keys and enter the low alarm value to be set.	
8		Press the  key. The changed setting is saved to the SFC.	
9	 or 	Press the  key or  key to show this screen.	
10		Press the  key. The changed setting is written into the database of the converter.	
11		Setting is completed. Press the  key, and return to the screen as in step 1.	

Deciding fail-safe direction: [F/S SET UP] function

Introduction

“Deciding fail-safe direction” refers to deciding the direction of output burnout if an error causes the converter to fail to measure the flow rate. For error, refer to “Error messages and remedial action” on page 6-32. There are three directions as shown below.

Analog output

- Burnout up (UP)Causes the readout of a signal from the converter to swing fully in the direction of a maximum value (21.8 mA TYP).
- Burnout down (DWN)..Causes the readout of a signal from the converter to swing fully in the direction of a minimum value (3.7 mA TYP).
- Hold (HLD)Holds the output immediately to a value before the error occurrence.

Pulse output





- Stop (STOP)Stops the pulse output
- Hold (HLD)Keeps the output immediately to value before the error occurrence.







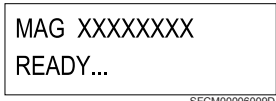

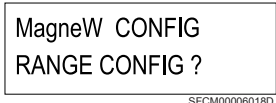





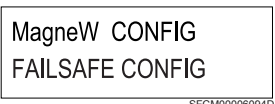









⚠ CAUTION





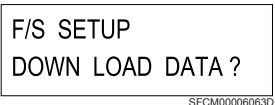

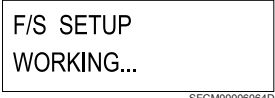
The fail-safe direction is a factor of extreme importance in securing the safety of the entire control process. Decide the fail-safe direction considering what would be the safer output when the output of the converter becomes abnormal in the entire control process.

Procedure

Use the following procedure to display or set the fail-safe direction of analog output.













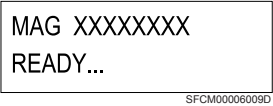

Step	Key	Procedure	SFC screen
1		Confirm that the SFC is set to “READY”. If it is not, press the  key to set it to “READY”.	
2		Press the  key to access the CONFIG functions.	















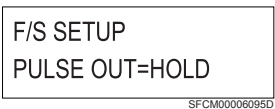

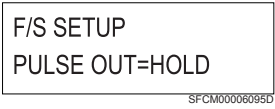





Step	Key	Procedure	SFC screen
3	 or 	Press the  key or  key to show this screen.	 <small>SFCM00006094D</small>
4		Press the  key.	 <small>SFCM00006020D</small>
5	 	Pressing the  key changes the screen sequentially from DWN → HLD → UP → DWN. Display the fail-safe direction to be set on the screen. Branch: <ul style="list-style-type: none"> To stop the fail-safe direction, setting press the  key. The screen will return to the one in step 3. 	 <small>SFCM00006061D</small>
6		Press the  key. Result: <ul style="list-style-type: none"> The screen to the right appears and the set fail-safe direction is confirmed. 	 <small>SFCM00006062D</small>
7	 or 	Press the  key or  key to show this screen (DOWN LOAD).	 <small>SFCM00006063D</small>
8		Press the  key. Result: <ul style="list-style-type: none"> The screen as shown on the right appears and the changed setting is written into the database of the converter. The screen returns to step 3. 	 <small>SFCM00006064D</small>  <small>SFCM00006065D</small>

Step	Key	Procedure	SFC screen
9	 + 	To exit the F/S SET UP function, press the  +  keys.	
10		Press the  key. Result: <ul style="list-style-type: none"> The screen exits the F/S SET UP function and returns to the screen as in step 1. 	

Setting burnout direction of pulse output: [F/S SETUP] function

Use the following procedure to display and to set the fail-safe direction of pulse output.













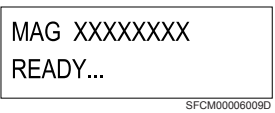





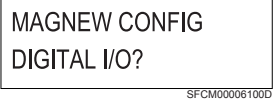



Step	Key	Procedure	SFC screen
1		Confirm that the SFC is set to "READY". If it is not, press the  key to set it to "READY".	
2		Press the  key to access the CONFIG functions.	
3	 or 	Press the  key or  key to show this screen.	
4		Press the  key.	

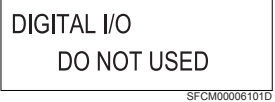









Step	Key	Procedure	SFC screen
5	 or 	Press the  key or  key to show this screen. Present burnout direction appears.	
6		Press the  key and select the output status to be set. You can select HOLD or STOP.	
7		Press the  key. Fail-safe direction, which is set, is confirmed.	
8	 OR 	Press the  key or  key to show this screen.	
9		Press the  key. The screen shown to the right appears and the changed setting is written into the database of the converter.	 
10	 	Setting is completed. Press the  key, and return to the screen as in step 1.	

Select pulse output / contact output [DIGITAL I/O] function

Two wired magnetic flowmeter can be configured for pulse output or contact output other than the analog current output (4-20 mA).



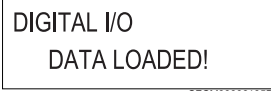

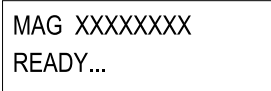







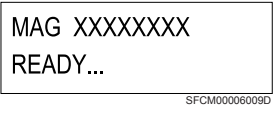





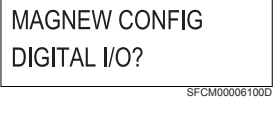



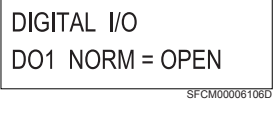
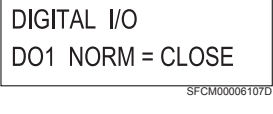

Use the following procedure to configure the pulse output and contact output.

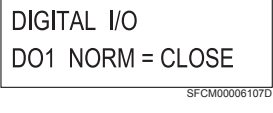



Step	Key	Procedure	SFC screen
1		Confirm that the SFC is set to "READY". If it is not, press the  key to set it to "READY".	
2	  OR 	Press the  key to access the CONFIG functions. Press the  key or  key to display the screen as shown on the right	
3	  OR 	Press the  key to access the DIGITAL I/O function, press the  key or  key to display the screen as shown on the right. Present setting function appears. DO NOT USED..... Pulse output HI-LO ALARM..... Contact output * Following function will appear on the screen but are not available for two wired magnetic flowmeter. ALARM DIAG EMPTY H1-L1/H2-L2 ALM	 or 
4		Press the  key and specify the function to be set.	
5		Press the  key. The changed setting is saved to the SFC.	

Step	Key	Procedure	SFC screen
6	 or 	Press the  key or  key to show this screen.	 <small>SFCM00006053D</small>
7		Press the  key. The changed setting is written into the database of the converter.	 <small>SFCM00006104D</small>  <small>SFCM00006105D</small>
8		Setting is completed. Press the  key, and return to the screen as in step 1.	 <small>SFCM00006009D</small>

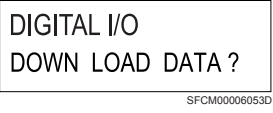
Setting contact output status [DIGITAL I/O] function

When contact output (HI-LO ALARM) is selected in the previous page, use the following procedure to set the contact output status (OPEN/CLOSE) in NORMAL status.

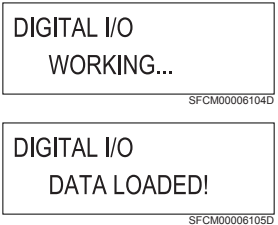

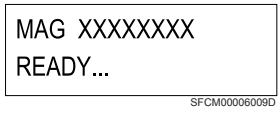









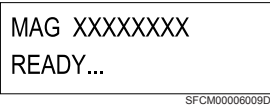













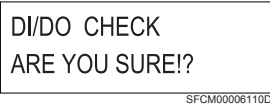

Step	Key	Procedure	SFC screen
1		Confirm that the SFC is set to "READY". If it is not, press the  key to set it to "READY".	
2	  OR 	Press the  key to access the CONFIG functions. Press the  key or  key to display the screen as shown on the right	
3	  OR 	Press the  key to access the DIGITAL I/O function, press the  key or  key to display the screen as shown on the right. The screen displays the setting of the contact output status (OPEN/CLOSE) in the actual NORMAL status.	 OR 
4		Press the  key and select the status to be set. You can select OPEN or CLOSE.	
5		Press the  key. The changed setting is saved to the SFC.	
6	 OR 	Press the  key or  key to show this screen.	





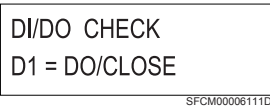







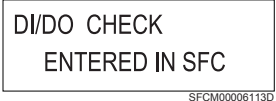

Step	Key	Procedure	SFC screen
7		<p>Press the  key.</p> <p>The changed setting is written into the database of the converter.</p>	
8		<p>Setting is completed. Press the  key, and return to the screen as in step 1.</p>	

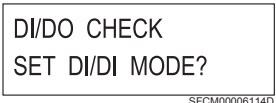
Checking output of contact output: [DI/DO CHECK] function

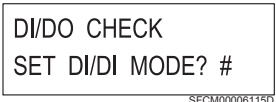
Output of the contact output can be checked from SFC.



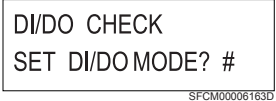

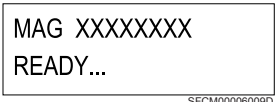





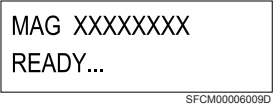

Use the following procedure to check the output of the contact output.

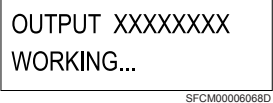
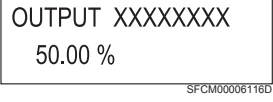

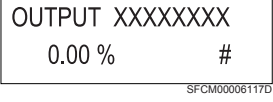

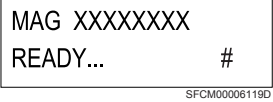



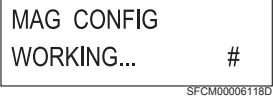
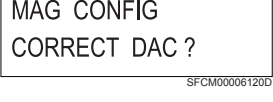

Step	Key	Procedure	SFC screen
1		Confirm that the SFC is set to "READY". If it is not, press the  key to set it to "READY".	
2	  or 	Press the  key to access the CONFIG functions. Press the  key or  key to show the screen here to the right	
3	  or 	Press the  key to access the CALIBRATE function, press the  key or  key to display the screen as shown on the right.	
4		Press the  key. The screen shown as shown on the right appears and you will be asked whether you want to check the contact output.	
5	  or 	Press the  key to access the DI/DO CHECK function. Press the  key or  key to show the screen here to the right. Present contact output status appears.	
6		Press the  key and select the status to be set. You can select OPEN or CLOSE.	

Step	Key	Procedure	SFC screen
7		Press the  key. The changed setting is saved to the SFC.	
8	 or 	Press the  key or  key to show this screen.	
9		Press the  key. The screen as shown on the right will appear. # mark will be displayed to the bottom right, and contact outputs according to the output status.	
10		After confirming, press the  key. The screen as shown on the right appears. Press the  key. The screen exists the contact output function	
11		Press the  key, and return to the screen as in step 1.	

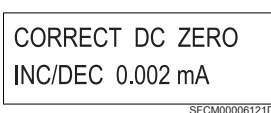
Adjusting analog current output [CORRECT DAC] function

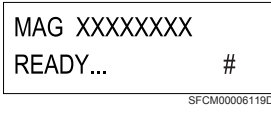
Analog current output can be adjusted from converter by changing it into constant current generation mode by SFC. Use the following procedure to adjust the analog current output.

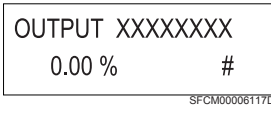

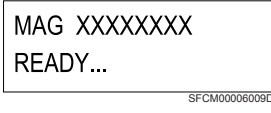









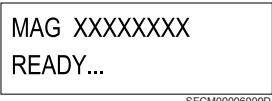



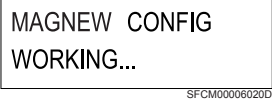
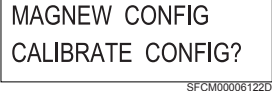

Step	Key	Procedure	SFC screen
1		Confirm that the SFC is set to "READY". If it is not, press the  key to set it to "READY".	
2		Press the  key. Actual output value will be displayed.	 
3		Press the numeric keys to enter the output value to be adjusted. For example, in case of adjusting 0%, enter "0%", and press the  key, the display as shown on the right appears. This display confirms constant current generation mode. Output value is fixed to 0% (4 mA) * "#" mark shown in the bottom right presents the constant current generation mode.	
4		Press the  key. Display returns back to the screen as in step 1. Output value is still fixed at 0%.	
5		Press the  key to access the [CONFIG] function. Press the  key or  key. Display as shown on the right appears.	 





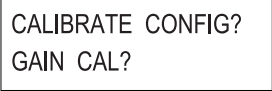



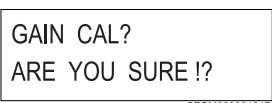

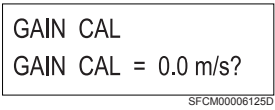
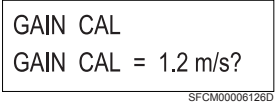

Step	Key	Procedure	SFC screen
6	<p>NON-VOL ENTER (Yes)</p> <p>DE CONF. MENU ITEM</p> <p>▲ H NEXT</p> <p>or</p> <p>▼ L PREV</p>	<p>Press the  key and enter into the CORRECT DAC screen. Current value shown in the bottom right screen presents the adjustment variation.</p> <p>By pressing the  key, you can change from 0.002, 0.01, 0.05 to 0.25 mA.</p> <p>Adjust by pressing the  key or  key.</p>	
7	<p>CLR (No)</p>	<p>Press the  key.</p> <p>Display return back to the screen shown to the right. # will be shown in the bottom right screen. This shows that it is still in constant current generation mode. You need to clear this mode.</p>	
8	<p>INPUT OUT- J PUT</p>	<p>Press the  key again.</p>	
9	<p>CLR (No)</p>	<p>Press the  key.</p> <p>Confirm that the “#” mark has been deleted.</p>	
10		<p>Adjust to 100% (20 mA) by following the same procedure as for adjusting 0% (4 mA).</p>	

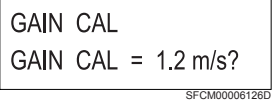
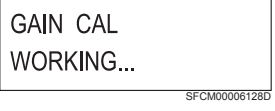
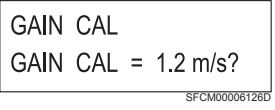
Calibrating gain constant [GAIN CAL] function

Gain constant of amplifier which is set inside the converter can be calibrated by using SFC. To do this, Yamatake’s smart calibrator (model MGZ14) will be required.



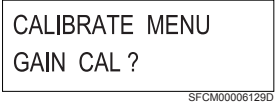

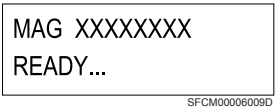







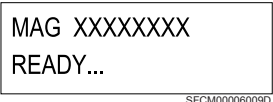







Use the following procedure to calibrate the gain constant.

Step	Key	Procedure	SFC screen
1		Confirm that the SFC is set to “READY”. If it is not, press the  key to set it to “READY”.	
2	  OR 	Press the  key to access the CONFIG functions. Press the  key or  key to display the screen as shown on the right	 
3	  OR 	Press the  key. Press the  key or  key to display the screen as shown on the right	
4		Press the  key. For gain calibration press the  key, again. Connect smart calibrator model MGZ14 to the converter; (For connecting and operating smart calibrator model MGZ14, refer to its user’s manual CM2-MGZ200-2001).	

Step	Key	Procedure	SFC screen
5	DE CONF. 	Display shown to the right appears. Press the  key and select the value to be calibrated. The value to gain calibrate for two wired magnetic flowmeter are the following three: 0 m/s, 2.5 m/s, and 10 m/s. Value 2.5 m/s for two wired magnetic flowmeter will be shown 1.2 m/s in SFC. When calibrating to 2.5 m/s select 1.2 m/s.	 
6	NON-VOL 	For example, when calibrating 2.5 m/s, displays screen as shown to the right. For smart calibrator model MGZ14, enter 2.5 m/s. Then, press  key. Gain calibration starts. When gain calibration completes, display will return back to the screen to select the gain calibration value.	  
7		Follow the same procedure for calibrating 0 m/s and 10 m/s.	
8	DE CONF. 	When gain calibration is completed, press the  key and the display as shown on the right appears.	
9	NON-VOL 	Press the  key. Exits from gain calibration function.	 
10		Press the  key and the screen returns to the screen as in step 1.	

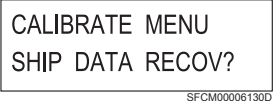

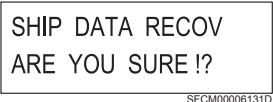
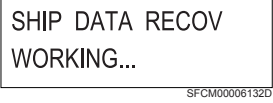
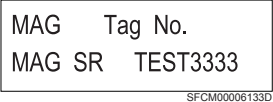

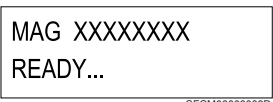





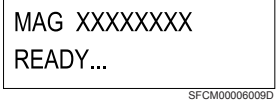

Resetting the internal data to factory setting (default) [SHIP DATA RECOV] function

By executing shipping data recovery, you can reset the two wired magnetic flowmeter to the default factory setting. (Please note that all the data will be reset when executing the [SHIP DATA RECOV] function.) Use the following procedure to execute the shipping data recovery.

Step	Key	Procedure	SFC screen
1		Confirm that the SFC is set to "READY". If it is not, press the  key to set it to "READY".	
2	  OR 	Press the  key to access the CONFIG functions. Press the  key or  key to display the screen as shown on the right	 
3	  OR 	Press the  key. Press the  key or  key to display the screen as shown on the right	
4		For [SHIPPING DATA RECOVERY], press the  key. Shipping data recovery function starts.	 
5		When shipping data recovery completes, the display as shown on the right appears.	
6		Press the  key and the screen returns to the screen as in step 1.	

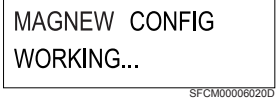
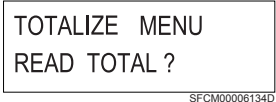
Displaying totalized value [READ TOTAL] function

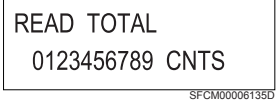

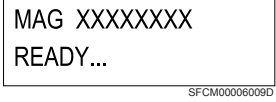









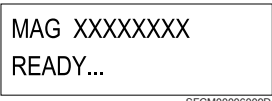



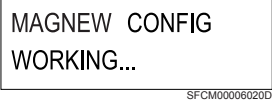
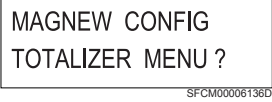

Use the following procedure to display the actual totalized value on the SFC screen.



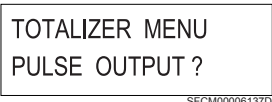

Step	Key	Procedure	SFC screen
1		Confirm that the SFC is set to "READY". If it is not, press the  key to set it to "READY".	
2	  OR 	Press the  key to access the CONFIG functions. Press the  key or  key to display the screen as shown on the right	 
3		Press the  key. Actual totalized value will be displayed as shown on the right.	
4		Press the  key and the screen returns to the screen as in step 1.	

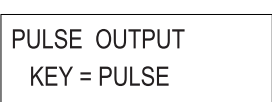
Checking pulse output [PULSE OUTPUT] function

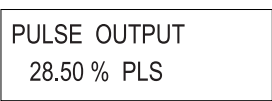
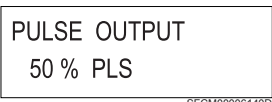
Pulse output can be checked by fixing the pulse output from the converter main body by using SFC.



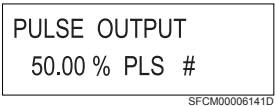

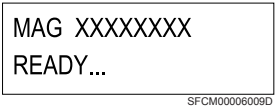







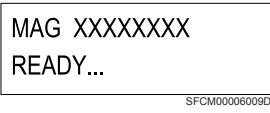





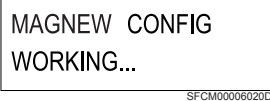





Use the following procedure to check the pulse output.

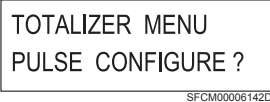





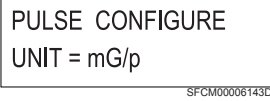

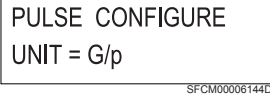







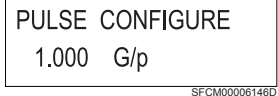
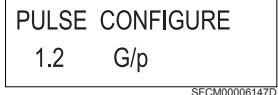

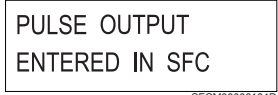
Step	Key	Procedure	SFC screen
1		Confirm that the SFC is set to "READY". If it is not, press the  key to set it to "READY".	
2	  OR 	Press the  key to access the CONFIG functions. Press the  key or  key to display the screen as shown on the right	 
3	  OR 	Press the  key to access the [TOTALIZER] functions. Press the  key or  key to display the screen as shown on the right	
4		Press the  key to display the screen as shown on the right.	
5		Press the  key, again. The actual pulse output will be displayed as shown on the right.	
6		Enter the output value to be checked into the screen as shown on the right using numeric key.	

Step	Key	Procedure	SFC screen
7		After entering the value, press the  key. Pulse output as a fixed value according to the entered value.	
8		After checking the pulse output, press the  key and the screen returns to the screen as in step 1.	

Setting pulse scale and pulse scale unit [PULSE CONFIGURE] function



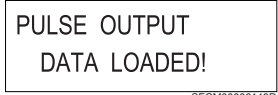

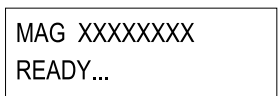







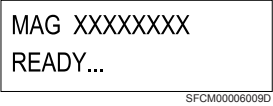





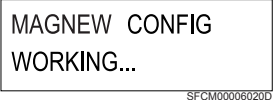
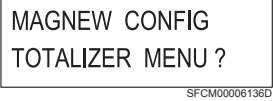

Use the following procedure to set the pulse scale and the pulse scale unit using SFC. However, set the span frequency range: 0.001 Hz to 200 Hz. (Span frequency is a pulse frequency when the maximum range (100%) of flow rate flows.)



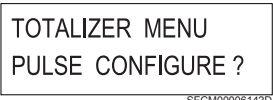





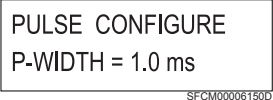



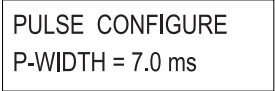

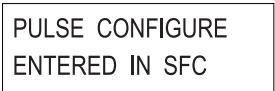
Step	Key	Procedure	SFC screen
1		Confirm that the SFC is set to "READY". If it is not, press the  key to set it to "READY".	
2	  or 	Press the  key to access the CONFIG functions. Press the  key or  key to display the screen as shown on the right	 
3	  or 	Press the  key to access the TOTALIZER functions. Press the  key or  key to display the screen as shown on the right	
4	  or 	Press the  key to enter into PULSE setting function and press the  key or  key to display the screen as shown on the right. Displays the actual pulse scale unit.	
5		Press the  key and select the unit to be set. Available units are in the actual unit system.	

Step	Key	Procedure	SFC screen
6		Press the  key. The changed setting is saved on the SFC.	 <small>SFCM00006146D</small>
7	 or 	Next, set pulse width. Press the  key or  key to display the screen as shown on the right. Actual pulse scale will be displayed. Enter the pulse scale you want to set by pressing the numeric keys.	 <small>SFCM00006146D</small>  <small>SFCM00006147D</small>
8		Press the  key. The changed setting is saved on the SFC.	 <small>SFCM00006164D</small>
9	 or 	Press the  key or  key to display the screen as shown on the right.	 <small>SFCM00006148D</small>
10		Press the  key. Changed setting data is written into the database of the converter.	 <small>SFCM00006149D</small>
11		Press the  key and the screen returns to the screen as in step 1.	 <small>SFCM00006009D</small>

Setting pulse width [PULSE CONFIGURE] function

Use the following procedure to set the pulse width. Available setting range of pulse width is DUTY rate < 70%

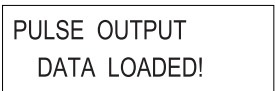

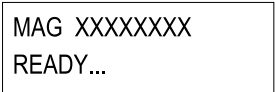









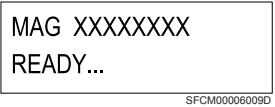





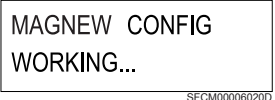
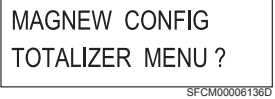

Step	Key	Procedure	SFC screen
1		Confirm that the SFC is set to "READY". If it is not, press the  key to set it to "READY".	
2	  or 	Press the  key to access the CONFIG functions. Press the  key or  key to display the screen as shown on the right	 
3	  or 	Press the  key to access the TOTALIZER functions. Press the  key or  key to display the screen as shown on the right	
4	  or 	Press the  key to enter into [PULSE] setting function and press the  key or  key to display the screen as shown on the right. Displays the actual pulse width.	



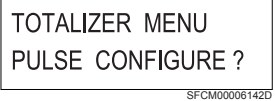





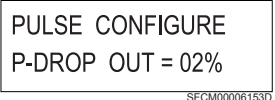



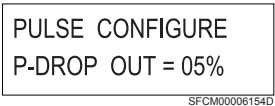

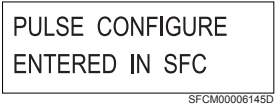
Step	Key	Procedure	SFC screen
5	DE CONF. 	Press the  key and select the pulse width to be set. (Select from duty 50, 1/7/10/15/30/50/100/200 ms) You can enter it directly by pressing the numeric keys. Range of two wired magnetic flowmeter is 1 to 1000 ms, however, SFC can only set up to 999.9 ms.	 <small>SFCM00006151D</small>
6	NON-VOL 	Press the  key. The changed setting is saved on the SFC.	 <small>SFCM00006145D</small>
7	 or 	Press the  key or  key to display the screen as shown on the right.	 <small>SFCM00006152D</small>
8	NON-VOL 	Press the  key. Changed setting data is written into the database of the converter.	 <small>SFCM00006149D</small>
9		Press the  key and the screen returns to the screen as in step 1.	 <small>SFCM00006009D</small>

Setting dropout [PULSE CONFIGURE] function

Dropout function is to fix the pulse output, which is caused by the output fluctuation near 0% of flow rate and is unrelated to the flow rate. Use the following procedure to set the dropout using SFC.



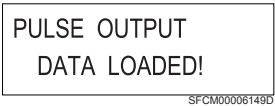

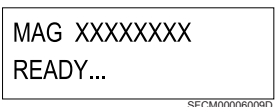







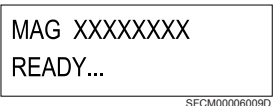





Range of the dropout setting is 0 to 10%.

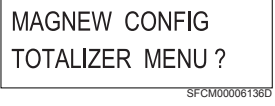





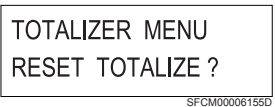

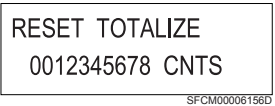
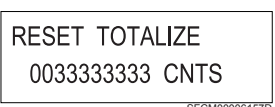

Step	Key	Procedure	SFC screen
1		Confirm that the SFC is set to "READY". If it is not, press the  key to set it to "READY".	
2	  OR 	Press the  key to access the CONFIG functions. Press the  key or  key to display the screen as shown on the right	 
3	  OR 	Press the  key to access the TOTALIZER functions. Press the  key or  key to display the screen as shown on the right	
4	  or 	Press the  key to enter into PULSE setting function and press the  key or  key to display the screen as shown on the right. Displays the actual dropout setting.	

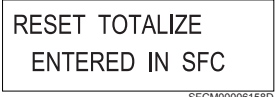
Step	Key	Procedure	SFC screen
5		Press the  key and select the dropout to be set.	
6		Press the  key. The changed setting is saved on the SFC.	
7	 or 	Next, set pulse width. press the  key or  key to display the screen as shown on the right.	
8		Press the  key. Changed setting data is written into the database of the converter.	
9		Press the  key and the screen returns to the screen as in step 1.	

Setting counter reset function [RESET TOTALZE] function

Resetting the totalized value and setting reset value are possible using the SFC. When resetting the totalized value, two wired magnetic flowmeter internal counter will be reset and start resetting from the reset value which has been set. You can enter the reset value maximum of 10 figures to SFC, however for two wired magnetic flowmeter only 8 figures are effective. Use the following procedure to reset the totalized value and to set the reset value.

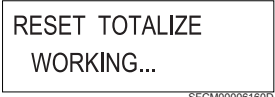
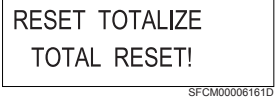
Step	Key	Procedure	SFC screen
1		Confirm that the SFC is set to "READY". If it is not, press the  key to set it to "READY".	
2	  OR 	Press the  key to access the CONFIG functions. Press the  key or  key to display the screen as shown on the right.	 
3	  OR 	Press the  key to access the TOTALIZER functions. Press the  key or  key to display the screen as shown on the right.	
4		Press the  key. Display the actual reset value.	
5		Enter the reset value to be set pressing the numeric keys.	

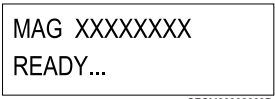
Step	Key	Procedure	SFC screen
6		Press the  key. The changed setting is saved on the SFC.	
7	 	Press the  key. The screen as shown on the right appears. To reset press the  key. Totalized value is reset.	  
8		After checking the pulse output, press the  key and the screen returns to the screen as in step 1.	

Chapter 7 : Operation using HART communicator

7-1 : Preparation for communication, verification and cautions on use

This section describes the preparation necessary for communication between a device and a HART Communicator. This section also covers the procedure to verify communication. The first step for preparation is to perform wiring between the converter and the HART Communicator. After wiring has been completed, turn the power on and verify that communications are functioning properly.

7-1-1 : Wiring between converter and HART Communicator

The following describes the methods of wiring between converter and HART Communicator.

Connect the HART Communicator as shown in Figure 7-1. A 250Ω resistor must be installed on the receiving end of the output current. There is no polarity on the HART Communicator terminal.

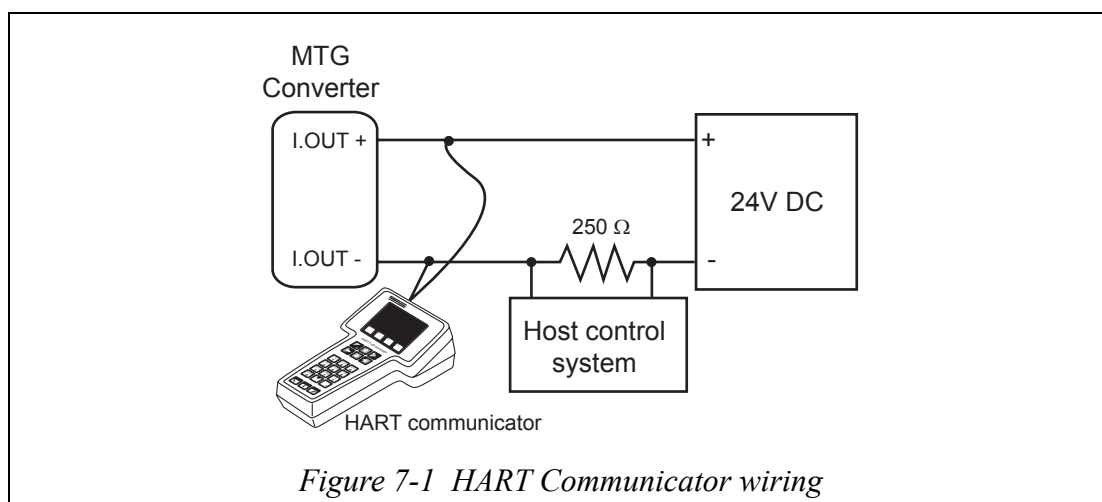

7-1-2 : Two wired magflow meter converter setting

Communication method selection

Set the converter's communication method to HART to communicate with HART Communicator.

Note that after changing the setting, when moving to the measuring mode by pressing the MODE key, converter will reboot.

HART: Set when executing the HART communication using HART Communicator.

SFN.A: Set when using the SFC with analog (4 to 20 mA) output mode

SFN.D: Set when DE (Digital Enhancement) communication is used.

NONE: Set when communication is not used.

Default setting is SFN.A: SFC analog output.

Follow the procedures described below to select the communication method.

Step	Procedure	Screen
1	The screen on the right is an example in the MEASURING MODE. Press the MODE key	<div style="border: 1px solid black; padding: 5px; width: fit-content;"> <p style="text-align: right;">20.0 %</p> <p style="text-align: right;">01.94 m³/h</p> <p>WP0 00069401</p> </div>
2	Operator's mode will be displayed approx.2 sec. And the damping setting display will appear.	<div style="border: 1px solid black; padding: 5px; width: fit-content;"> <p style="text-align: right;">20.0 %</p> <p>* OPERATOR'S</p> <p style="text-align: right;">MODE</p> </div> <div style="border: 1px solid black; padding: 5px; width: fit-content;"> <p style="text-align: right;">20.0 %</p> <p>* DAMPING</p> <p style="text-align: right;">005.0 s</p> </div>
3	Press the ↑ key 3 times. The screen as shown on the right will appear.	<div style="border: 1px solid black; padding: 5px; width: fit-content;"> <p style="text-align: right;">20.0 %</p> <p>* COM SELECT</p> <p style="text-align: right;">SFN. A</p> </div>
4	Move the cursor to the communication method (SFN.A, SFN.D, NONE, HART) by pressing the → key. The screen as shown on the right is an example of when SFN.A is selected for communication method.	<div style="border: 1px solid black; padding: 5px; width: fit-content;"> <p style="text-align: right;">20.0 %</p> <p>* COM SELECT</p> <p style="text-align: right;">SFN. A</p> </div>
5	Press the ↑ key or ↓ key, and select the HART communication method.	<div style="border: 1px solid black; padding: 5px; width: fit-content;"> <p style="text-align: right;">20.0 %</p> <p>* COM SELECT</p> <p style="text-align: right;">HART</p> </div>

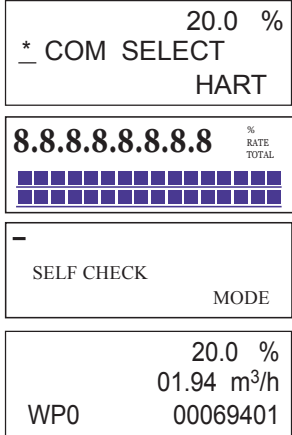
Step	Procedure	Screen
6	<p>Press the → key and move the cursor to the bottom of the *.</p> <p>After rebooting the converter by pressing the MODE key, display will return to the MEASURING MODE and the communication method will be changed.</p>	 <p>The screenshots show the following content:</p> <ul style="list-style-type: none"> Top screen: 20.0 %, * COM SELECT, HART Middle screen: 8.8.8.8.8.8.8.8, RATE, TOTAL Bottom screen: SELF CHECK, MODE

7-1-3 : Verifying communication

After the HART Communicator has been properly interconnected, turn the device's power on. For the external power supply model, turn on the external power supply before turning the device power on.

Once the setting and wiring connections are correct, the HART Communicator's display shows an online menu as shown below and a HART mark will flicker in the upper right hand corner of the display.

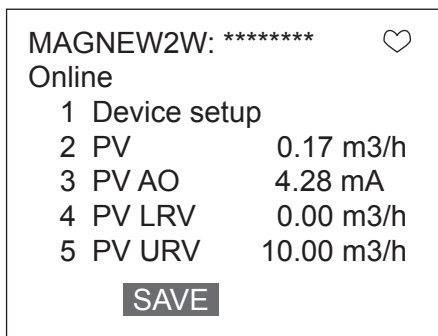

Figure 7-2 Online menu

If the display is not as shown in Figure 7-2 but as shown in Figure 7-3 below, no communications are being made. Recheck the HART Communicator connections and the setting of converter. (The setting of the converter is described page 7-2.)

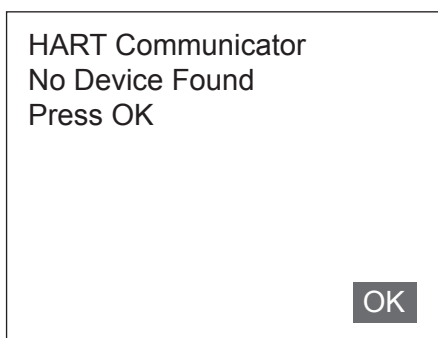

Figure 7-3 Communication not available

7-1-4 : Cautions

CAUTION

Do not remove the HART Communicator cable from the converter while executing communication. If the cable is disconnected during data setting transmission there will be no data transfer to the converter.

7-2 : Setting and calibrating devices using the HART Communicator

The HART Communicator enables the user to set a two wired magnetic flowmeter device as well as allowing them to adjust and check the output of the device and to inspect the device. The following values can be set using the HART Communicator:

- Flow unit
- Range
- Specific gravity
- Damping time constant
- Display selection
- Function selection
- Correction coefficient
- Communication method
- Detector diameter
- Detector constant
- Auto spike cut
- Average processing selection
- Average processing time
- Low flow cut
- Drop out
- Pulse scale unit
- Pulse scale
- Pulse width
- Totalized value of integral counter display
- Reset value of integral counter
- Integral counter reset
- High alarm value setting
- Low alarm value setting
- Setting output status setting
- Burnout (Analog output) setting
- Burnout (Pulse output) setting

Also, the following calibrations and inspection can be made:

- Zero point adjustment
- Current output calibration at 4 mA and 20 mA
- Gain adjustment
- Pulse output adjustment
- Excitation current output adjustment
- Analog output check
- Pulse output check
- Contact output check
- Converter status check
- Tag setting
- Shipping data recovery
- Equipment information check

For a detailed list of all the menus, see the HART Communicator's menu table for the two wired magnetic flowmeter at the back of this manual.

7-2-1 : Setting procedures

The procedures to set various device values are described in this section.

Flow units

The unit for the flow is to be set as follows:

1. Select “1. Device setup” from online menu 1 (Figure 7-4). The device setup menu will then be displayed. (Figure 7-4)

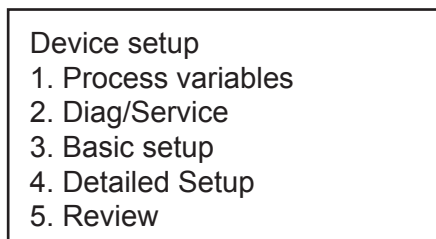

Figure 7-4 Device setup menu

2. Select “3. Basic setup” from the menu and then the basic setup menu will be displayed. (Figure 7-5)

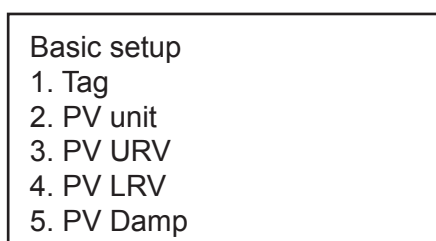

Figure 7-5 Basic setup menu

3. Select “2. PV unit” from the basic setup menu.

4. Once the display as shown in Figure 7-6 appears, move the arrow key up or down to select a flow unit. After making a selection, press F4 (ENTER). If F3 (ESC) is pressed here, the selection will be canceled and the display will return to the basic menu.

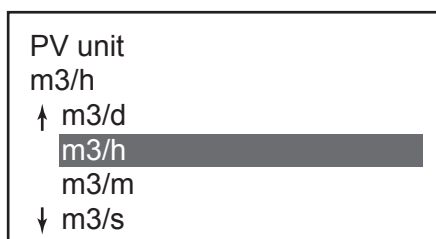

Figure 7-6 Selection of flow rate unit

5. After pressing F4 (ENTER) and returning to the basic menu, press F2 (SEND). The HART mark will appear in the upper right hand corner while HART is communicating with the device. (Figure 7-7) Once communication is complete, the HART mark will disappear.

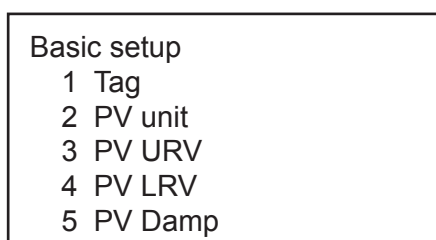

Figure 7-7 Transmitting the setting

Range

The upper limit of the flow range is set as follows:

1. From online menu,
Select:
 1. Device setup
 - 3. Basic setup
 - 3. PV URV
 Figure 7-8 will then be displayed.

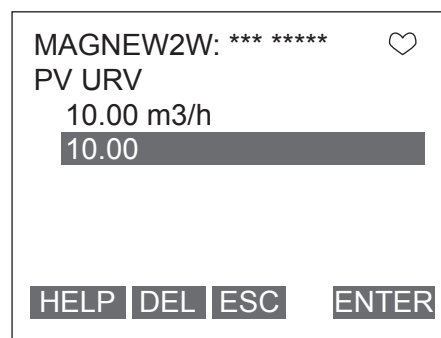

Figure 7-8

2. Use the numeric keys to enter a new range value in the value input display. Up to six digits including a decimal point can be entered. Setting range of the flow range is 0.3 m/s to 10 m/s in flow rate.
3. Once a new value is entered, press F4 (ENTER) to return to the basic setup menu. When the value is outside the range, error will be displayed. Input the value again.
4. After returning to the basic setup menu, press F2 (SEND). Changed setting will be transmitted to the converter. The HART Communicator mark will appear on the upper right hand corner while HART is communicating with the device. The mark will disappear once communication has properly completed.

Specific gravity

The specific gravity, when selecting the unit of weight is set as follows:

1. From online menu,
Select:
 1. Device setup
 - 3. Basic setup
 - 4. Gravity
 Figure 7-9 will then be displayed.

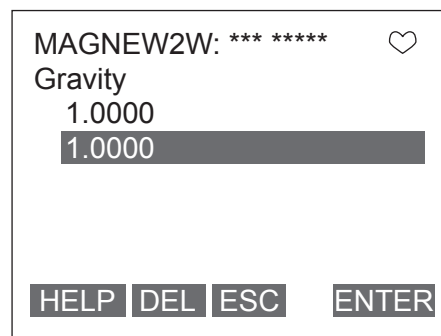

Figure 7-9

2. Use the numeric keys to enter a specific gravity value in the value input display. Up to six digits including a decimal point can be entered. Setting range of the specific gravity is 0.1000 to 5.9999.
3. Once a new value is entered, press F4 (ENTER) to return to the basic setup menu. When the entered value is outside the range, error will be displayed. Input the value again.
4. After returning to the basic setup menu, press F2 (SEND). Changed setting will be transmitted to the converter. The HART Communicator mark will appear on the upper right hand corner while HART is communicating with the device. The mark will disappear once communication has properly completed.

Damping time constant

The damping time constant is set as follows:

1. From online menu,
Select:
1. Device setup
→ 3. Basic setup
→ 5. PV Damp
Figure 7-10 will then be displayed.

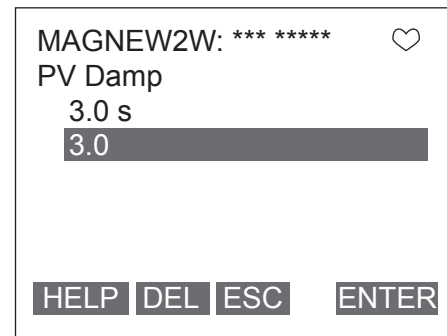

Figure 7-10

2. Use the numeric keys to enter a damping time constant value in the value input display. Up to five digits including a decimal point can be entered. Setting range of the damping constant is 0.5 to 199.9.
3. Once a new value is entered, press F4 (ENTER) to return to the basic setup menu. When the value is outside the range, error will be displayed. Input the value again.
4. After returning to the basic setup menu, press F2 (SEND). Changed setting will be transmitted to the converter. The HART Communicator mark will appear on the upper right hand corner while HART is communicating with the device. The mark will disappear once communication has properly completed.

Zero adjustment

Follow the steps described below to set the momentarily flow of static pressure to zero.

1. Stop and make sure that the fluid to be calibrated inside the flowmeter is static.
2. From online menu,
Select:
1. Device setup
→ 3. Basic setup
→ 6. Auto zero trim
Figure 7-11 will then be displayed.
To adjust the zero point, press F4 (OK). It will take approx. 120 sec. to adjust the zero point.

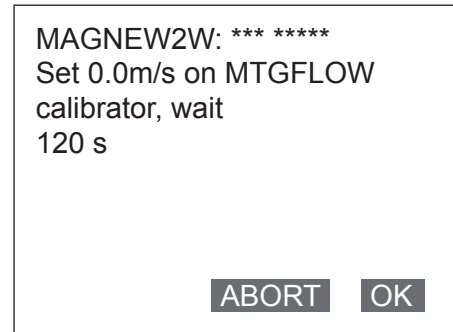

Figure 7-11

3. When F4 (OK) is pressed, Figure 7-12 will be displayed and starts adjusting the zero point. By pressing F3 (ABORT) the procedure is canceled.

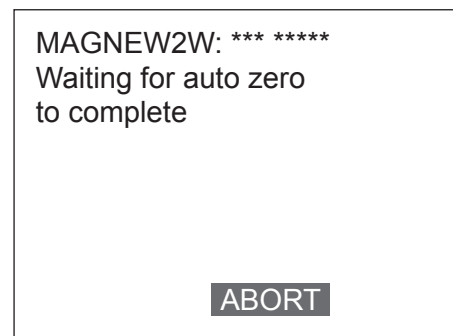

Figure 7-12

4. Once zero point adjustment is completed, Figure 7-13 is displayed. Press F4 (OK) and return to the online menu.

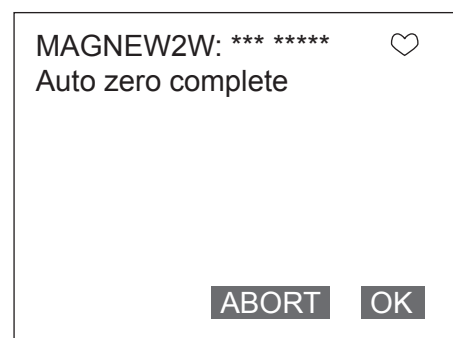

Figure 7-13

Selecting display

The display selection is set as follows:

1. From online menu,
Select:
 1. Device setup
 - 3. Basic setup
 - 7. Display select
 Figure 7-14 will then be displayed.

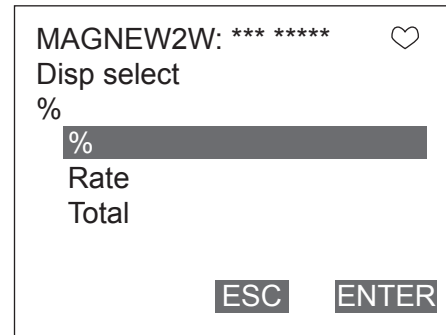

Figure 7-14

2. Once the display as shown in Figure 7-14 appears, move the arrow key up or down to select a display. After making a selection, press F4 (ENTER). % / Rate / TOTAL can be selected. If F3 (ESC) is pressed here, the selection will be canceled and the display will return to the basic menu.
3. After returning to the basic setup menu, press F2 (SEND). Changed setting will be transmitted to the converter. The HART Communicator mark will appear on the upper right hand corner while HART is communicating with the device. The mark will disappear once communication has properly completed.

Selecting function

Pulse output and contact output can be selected.

Follow the procedures described below to select pulse output or contact output.

1. From online menu,
Select:
 1. Device setup
 - 3. Basic setup
 - 8. Func set
 Figure 7-15 will then be displayed.

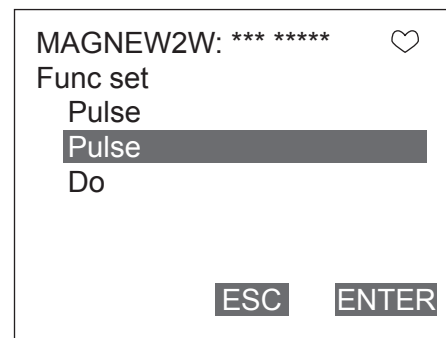

Figure 7-15

2. Once the display as shown in Figure 7-15 appears, move the arrow key up or down to select a display. After making a selection, press F4 (ENTER). Pulse (Pulse output) • Do (contact output) can be selected. If F3 (ESC) is pressed here, the selection will be canceled and the display will return to the basic menu.
3. After returning to the basic setup menu, press F2 (SEND). Changed setting will be transmitted to the converter. The HART Communicator mark will appear on the upper right hand corner while HART is communicating with the device. The mark will disappear once communication has properly completed.

Correction coefficient setting

Correction coefficient can be set in case multiplying the correction coefficient to the output flow rate according to its need.

The correction coefficient is set as follows:

1. From online menu,
Select:
1. Device setup
→ 3. Basic setup
→ 9. Coefficient
Figure 7-16 will then be displayed.

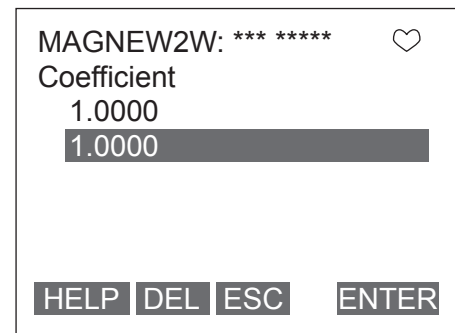

Figure 7-16

2. Use the numeric keys to enter a correction coefficient value in the value input display. Up to six digits including a decimal point can be entered. Setting range of correction coefficient is 0.1000 to 5.9999.
3. Once a new value is entered, press F4 (ENTER) to return to the basic setup menu. When the value is outside the range, error will be displayed. Input the value again.
4. After returning to the basic setup menu, press F2 (SEND). Changed setting will be transmitted to the converter. The HART Communicator mark will appear on the upper right hand corner while HART is communicating with the device. The mark will disappear once communication has properly completed.

Changing communication method

This function is used when changing the communication method from HART communication to SFN communication or without communication. This function is not used normally. If changing the communication method other than the HART, HART communication cannot be used. Therefore, if changing the communication other than the HART, see 7-1-2 : "Two wired magflow meter converter setting" and set the communication method to HART.

1. From online menu,
Select:
 1. Device setup
 - 4. Detailed setup
 - 2. Conf output
 - 6. COMM output
 Figure 7-17 will then be displayed.

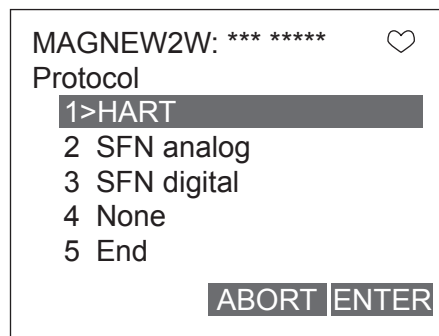

Figure 7-17

2. Once the display as shown in Figure 7-17 appears, move the arrow key up or down to select communication method. After making a selection, press F4 (ENTER). If F3 (ABORT) is pressed here, the selection will be canceled and the display will return to the COMM output menu.
3. When F4 (ENTER) is pressed, Figure 7-18 will be displayed for confirmation. If communication method is correct select "Yes" and press F4 (ENTER). If "No" selected or F3 (ABORT) is pressed here, selection will be canceled and the display will return to selecting menu display.

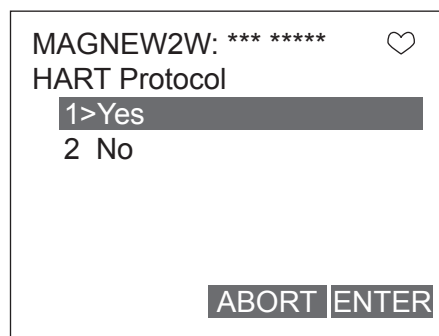

Figure 7-18

7-2-2 : Setting converter data

Detector diameter

Follow the procedures described below to set the detector diameter.

Set the diameter size printed on the nameplate.

1. From online menu,
Select:
 1. Device setup
 - 4. Detailed setup
 - 1. Detector config
 - 1. Tube sizeFigure 7-19 will then be displayed.

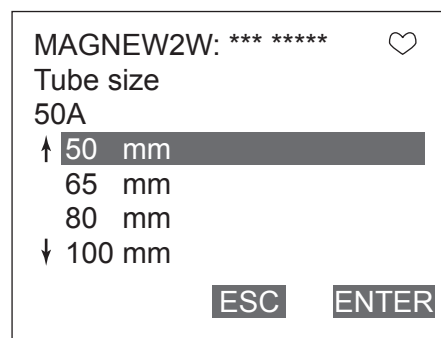

Figure 7-19

2. Once the display as shown in Figure 7-19 appears, move the arrow key up or down to select a detector diameter. After making a selection, press F4 (ENTER). If F3 (ESC) is pressed here, the selection will be canceled and the display will return to the Detector config menu.
3. After returning to the Detector config menu, press F2 (SEND). Changed setting will be transmitted to the converter. The HART communicator mark will appear on the upper right hand corner while HART is communicating with the device. The mark will disappear once communication has properly completed.

Detector type

Follow the procedures described below to set the detector type.

Use MTG at normal measurement.

1. From online menu,
Select:
 1. Device setup
 - 4. Detailed setup
 - 1. Detector config
 - 2. Detector typeFigure 7-20 will then be displayed.

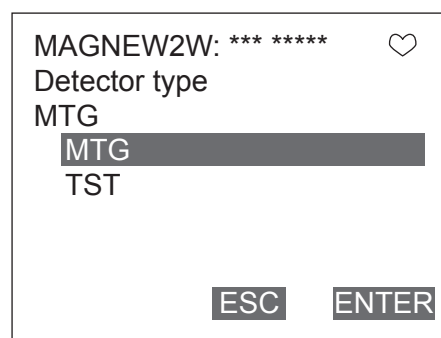

Figure 7-20

2. Once the display as shown in Figure 7-20 appears, move the arrow key up or down to select a detector type. After making a selection, press F4 (ENTER). If F3 (ESC) is pressed here, the selection will be canceled and the display will return to the Detector config menu.
3. After returning to the Detector config menu, press F2 (SEND). Changed setting will be transmitted to the converter. The HART communicator mark will appear on the upper right hand corner while HART is communicating with the device. The mark will disappear once communication has properly completed.

Detector constant

Follow the procedures described below to set the detector constant.

Set the detector constant (Ex value) printed on the nameplate.

1. From online menu,
Select:
 1. Device setup
 - 4. Detailed setup
 - 1. Detector config
 - 3. Ex valueFigure 7-21 will then be displayed.

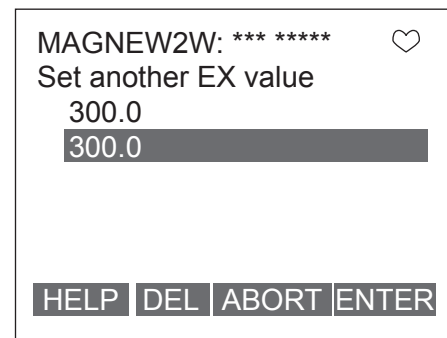

Figure 7-21

2. Use the numeric keys to enter a detector constant in the value input display. Up to 5 digits including a decimal point can be entered. Setting range of the detector constant is 200.0 to 699.9. will be canceled and the display will return to the Detector config menu.
3. Once a new value is entered, press F4 (ENTER) to return to the Detector config menu. When the value is outside the range, error will be displayed. Input the value again.
4. After returning to the Detector config menu, press F2 (SEND). Changed setting will be transmitted to the converter. The HART communicator mark will appear on the upper right hand corner while HART is communicating with the device. The mark will disappear once communication has properly completed.

7-2-3 : Signal processing

Auto spike cut

To set On/OFF for auto spike cut, proceed as follows:

1. From online menu,
Select:
1. Device setup
→ 4. Detailed setup
→ 3. Noise immunity
→ 2. Auto spike cut
Figure 7-22 will then be displayed.

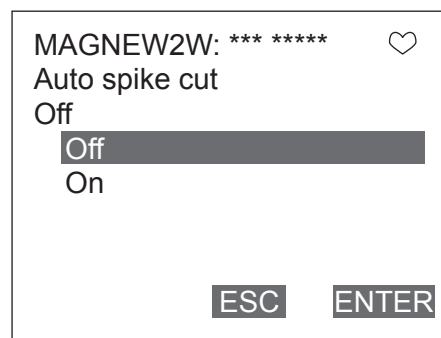

Figure 7-22

2. Once the display as shown in Figure 7-22 appears, move the arrow key up or down to select On or OFF. After making a selection, press F4 (ENTER). If F3 (ESC) is pressed here, the selection will be canceled and the display will return to the Noise immunity menu.
3. After returning to the Noise immunity menu, press F2 (SEND). Changed setting will be transmitted to the converter. The HART communicator mark will appear on the upper right hand corner while HART is communicating with the device. The mark will disappear once communication has properly completed.

Setting average processing

To set ON/OFF for average processing, proceed as follows:

1. From online menu,
Select:
1. Device setup
→ 4. Detailed setup
→ 3. Noise immunity
→ 3. Moving average
Figure 7-23 will then be displayed.

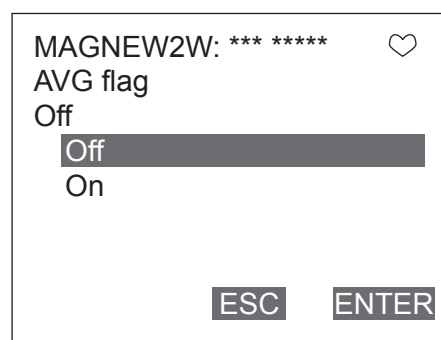

Figure 7-23

2. Once the display as shown in Figure 7-23 appears, move the arrow key up or down to select On or OFF. After making a selection, press F4 (ENTER). If F3 (ESC) is pressed here, the selection will be canceled and the display will return to the Noise immunity menu.
3. After returning to the Noise immunity menu, press F2 (SEND). Changed setting will be transmitted to the converter. The HART communicator mark will appear on the upper right hand corner while HART is communicating with the device. The mark will disappear once communication has properly completed.

Setting the average processing time

To set the value of the average processing time, proceed as follows:

1. From online menu,
Select:
 1. Device setup
 - 4. Detailed setup
 - 3. Noise immunity
 - 4. Mvng av time
 Figure 7-24 will then be displayed.

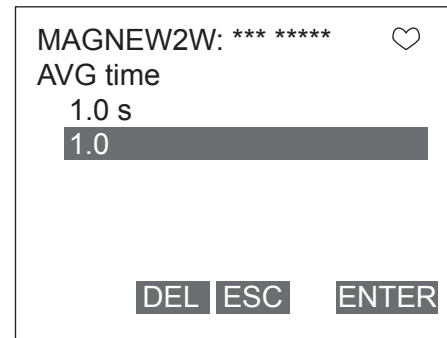

Figure 7-24

2. Use the numeric keys to enter an average processing time in the value input display. Setting range of average processing time 1.0s to 30.0s.
3. Once a new value is entered, press F4 (ENTER) to return to the Noise immunity menu. When the value is outside the range, error will be displayed. Input the value again.
4. After returning to the Noise immunity menu, press F2(SEND). Changed setting will be transmitted to the converter. The HART communicator mark will appear on the upper right hand corner while HART is communicating with the device. The mark will disappear once communication has properly completed.

Low flow cutoff

To set the low flow cutoff, proceed as follows:

1. From online menu,
Select:
 1. Device setup
 - 4. Detailed setup
 - 3. Noise immunity
 - 5. Lo flow cut
 Figure 7-25 will then be displayed.

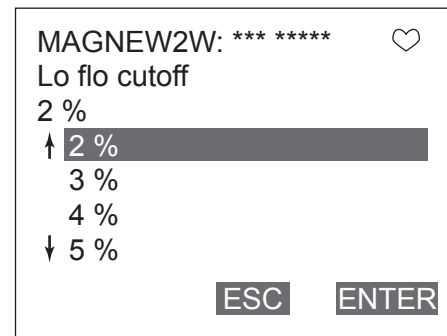

Figure 7-25

2. Once the display as shown in Figure 7-25 appears, move the arrow key up or down to select low flow cut value. Value can be specified from 1% to 10%. After making a selection, press F4(ENTER). If F3 (ESC) is pressed here, the selection will be canceled and the display will return to the Noise immunity menu.
3. After returning to the Noise immunity menu, press F2(SEND). Changed setting will be transmitted to the converter. The HART communicator mark will appear on the upper right hand corner while HART is communicating with the device. The mark will disappear once communication has properly completed.

Drop-out

When the drop-out is set to prevent the wrong integration of integrated flow rate, it will not count the pulse when it is within the flow rate of setting against the setting range.

To set the drop-out, proceed as follows:

1. From online menu,
Select:
1. Device setup
→ 4. Detailed setup
→ 3. Noise immunity
→ 6. Drop out
Figure 7-26 will then be displayed.

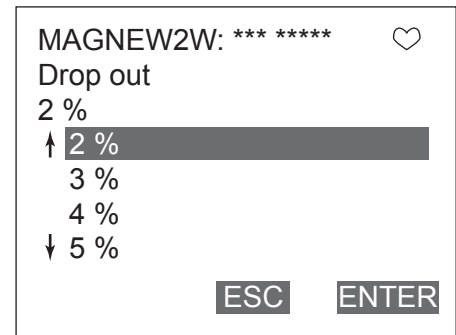

Figure 7-26

2. Once the display as shown in Figure 7-26 appears, move the arrow key up or down to select drop-out value. Value can be specified from 0% to 10%. After making a selection, press F4(ENTER). If F3 (ESC) is pressed here, the selection will be canceled and the display will return to the Noise immunity menu.
3. After returning to the Noise immunity menu, press F2(SEND). Changed setting will be transmitted to the converter. The HART communicator mark will appear on the upper right hand corner while HART is communicating with the device. The mark will disappear once communication has properly completed.

7-2-4 : Pulse setting

Pulse scale unit

To set the pulse scale unit, proceed as follows:

1. From online menu, Select:
 1. Device setup
 - 4. Detailed setup
 - 2. Conf output
 - 2. Pulse output
 - 1. Puls out unit
 Figure 7-27 will then be displayed.

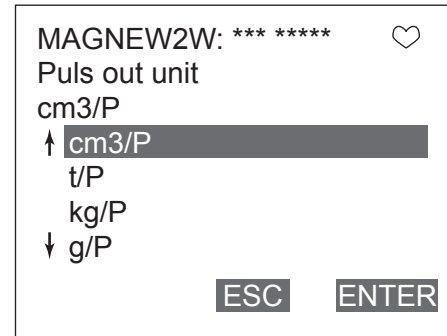

Figure 7-27

2. Once the display as shown in Figure 7-27 appears, move the arrow key up or down to select pulse scale unit. After making a selection, press F4 (ENTER). If F3 (ESC) is pressed here, the selection will be canceled and the display will return to the Pulse output menu.
3. After returning to the Pulse output menu, press F2 (SEND). Changed setting will be transmitted to the converter. The HART communicator mark will appear on the upper right hand corner while HART is communicating with the device. The mark will disappear once communication has properly completed.

Pulse scale

To set the pulse scale, proceed as follows:

1. From online menu, Select:
 1. Device setup
 - 4. Detailed setup
 - 2. Conf output
 - 2. Pulse output
 - 2. Puls scaling
 Figure 7-28 will then be displayed.

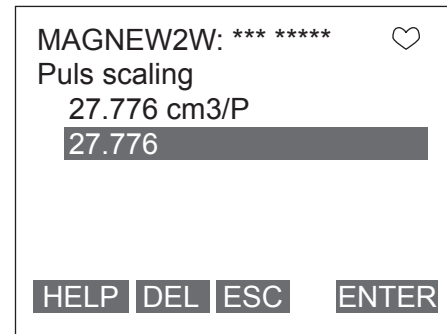

Figure 7-28

2. Use the numeric keys to enter a pulse scale in the value input display. Setting range of pulse scale is span frequency of 0.0001 Hz to 200 Hz.
3. Once a new value is entered, press F4 (ENTER) to return to the Noise immunity menu. When the value is outside the range, error will be displayed. Input the value again.
4. After returning to the Noise immunity menu, press F2 (SEND). Changed setting will be transmitted to the converter. The HART communicator mark will appear on the upper right hand corner while HART is communicating with the device. The mark will disappear once communication has properly completed.

Pulse width

To set the pulse width value, proceed as follows:

1. From online menu,
Select:
 1. Device setup
 - 4. Detailed setup
 - 2. Conf output
 - 2. Pulse output
 - 3. Pulse widthFigure 7-29 will then be displayed.

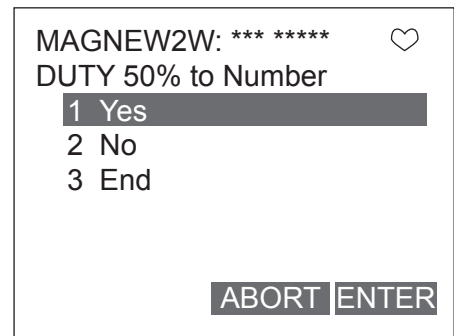

Figure 7-29

2. Duty ratio is set 50%. If setting the value arbitrarily, select YES, and press F4 (ENTER). If duty ratio of 50% is fine, select NO.
3. Use the numeric keys to enter a pulse width in the value input display. Setting range of pulse width is duty ratio of 70% or less.

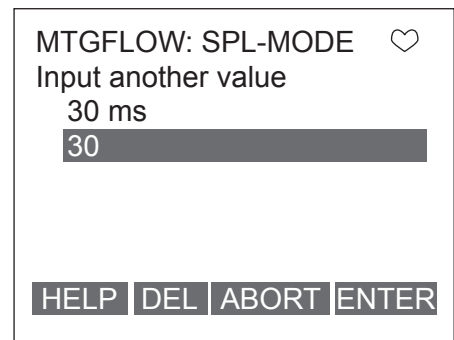

Figure 7-30

4. Once a new value is entered, press F4 (ENTER). Data will be transmitted. When the value is outside the range, error will be displayed. Input the value again.

7-2-5 : Totalized value setting

Displaying totalized value

Follow the procedures described below to display the actual totalized value.

1. From online menu,
Select:
 1. Device setup
 - 4. Detailed setup
 - 2. Conf output
 - 3. Totalizer
 - 1. Totalizer display
 Figure 7-31 will then be displayed.



Figure 7-31

2. Press F4 (EXIT) to return to the previous display.

Integrated reset value

Follow the procedure described below to set the integrated reset value.

1. From online menu,
Select:
 1. Device setup
 - 4. Detailed setup
 - 2. Conf output
 - 3. Totalizer
 - 2. Totalizer restart val
 Figure 7-32 will then be displayed.

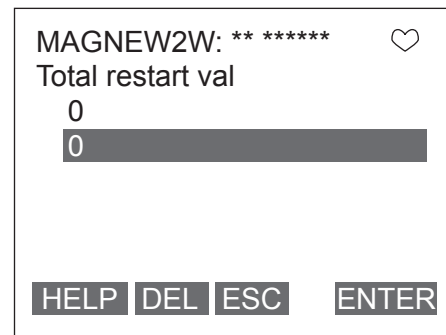

Figure 7-32

2. Use the numeric keys to input a integrated reset value.
Integrated reset value is span frequency of 00000000 to 99999999.
3. Once a new value has been inputted, press F4 (ENTER).
4. After pressing F4 (ENTER) and returning to the Totalizer menu, press F2 (SEND) to transmit the change to the converter. The HART communication will appear in the upper right hand corner while HART is communicating with the device. The mark will disappear once communication is properly completed.

Resetting the totalized value

Follow the procedure described below to reset the totalized value.

1. From online menu,
Select:
 1. Device setup
 - 4. Detailed setup
 - 2. Conf output
 - 3. Totalizer
 - 3. Reset totalizerFigure 7-33 will then be displayed.

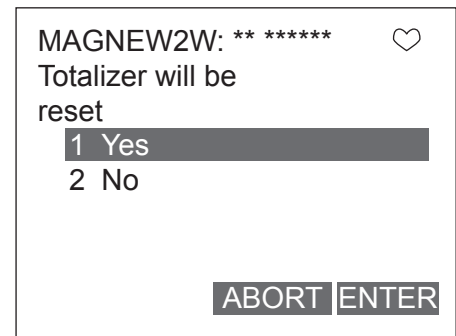

Figure 7-33

2. If resetting the totalized value, select Yes, and press F4.
3. After pressing F4 (ENTER), Figure 7-34 will then be displayed. Figure 7-34 shows that the totalized value has been reset. After resetting, display will automatically return back to the previous display in 3 sec.

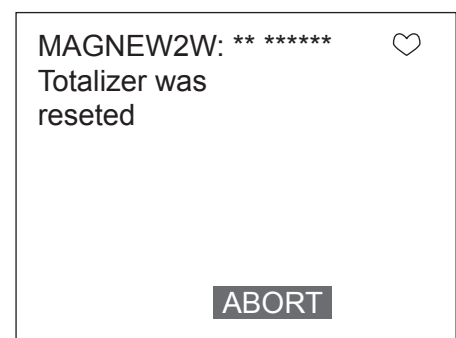

Figure 7-34

7-2-6 : Contact output setting

High alarm value setting

To set the high alarm value of contact output, proceeds as follows:

1. From online menu,
Select:
 1. Device setup
→ 4. Detailed setup
→ 2. Conf output
→ 4. Digital output
→ 1. Hi alarmFigure 7-35 will then be displayed.

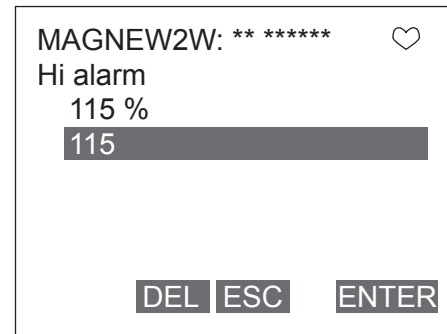

Figure 7-35

2. Use the numeric keys to enter a high alarm value in the value input display. Setting range of high alarm value is 0% to +115%. Do not set the value to be High alarm value < Low alarm value.
3. Once a new value is entered, press F4 (ENTER) to return to the Digital output menu. When the value is outside the range, error will be displayed. Input the value again.
4. After returning to the Digital output menu, press F2 (SEND). Changed setting will be transmitted to the converter. The HART communicator mark will appear on the upper right hand corner while HART is communicating with the device. The mark will disappear once communication has properly completed.

Low alarm value setting

To set the low alarm value of contact output, proceed as follows:

1. From online menu, Select:
 1. Device setup
 - 4. Detailed setup
 - 2. Conf output
 - 4. Digital output
 - 2. Low alarm
 Figure 7-36 will then be displayed.

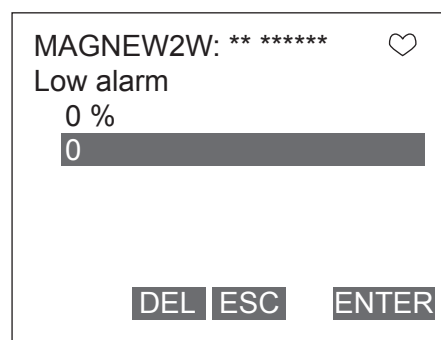

Figure 7-36

2. Use the numeric keys to enter a high alarm value in the value input display. Setting range of high alarm value is 0% to +115%. Do not set the value to be High alarm value < Low alarm value.
3. Once a new value is entered, press F4 (ENTER) to return to the Digital output menu. When the value is outside the range, error will be displayed. Input the value again.
4. After returning to the Digital output menu, press F2 (SEND). Changed setting will be transmitted to the converter. The HART communicator mark will appear on the upper right hand corner while HART is communicating with the device. The mark will disappear once communication has properly completed.

Contact output status setting

To select OPEN/CLOSE of contact output in normal status, proceed as follows:

1. From online menu, Select:
 1. Device setup
 - 4. Detailed setup
 - 2. Conf output
 - 4. Digital output
 - 3. Burn out DO
 Figure 7-37 will then be displayed.

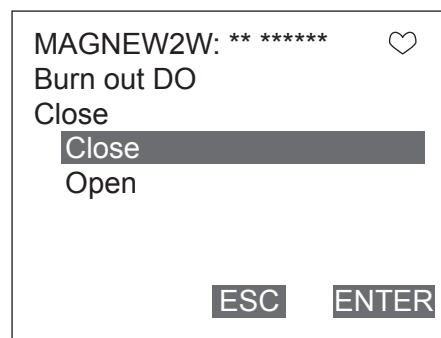

Figure 7-37

2. Once the display as shown in Figure 7-37 appears, move the arrow key up or down to select OPEN or CLOSE. After making a selection, press F4 (ENTER). If F3 (ESC) is pressed here, the selection will be canceled and the display will return to the Digital output menu.
3. After returning to the Digital output menu, press F2 (SEND). Changed setting will be transmitted to the converter. The HART communicator mark will appear on the upper right hand corner while HART is communicating with the device. The mark will disappear once communication has properly completed.

7-2-7 : Burnout setting

Analog output burnout setting

To set the output direction of analog current output at critical failure, proceed as follows:

1. From online menu,
Select:
 1. Device setup
 - 4. Detailed setup
 - 2. Conf output
 - 1. Analog output
 - 5. Burn out AO
- Figure 7-38 will then be displayed.



Figure 7-38

2. Once the display as shown in Figure 7-38 appears, move the arrow key up or down to select HIGH, LOW, or HOLD. After making a selection, press F4 (ENTER). If F3 (ESC) is pressed here, the selection will be canceled and the display will return to the Analog output menu.
3. After returning to the Analog output menu, press F2 (SEND). Changed setting will be transmitted to the converter. The HART communicator mark will appear on the upper right hand corner while HART is communicating with the device. The mark will disappear once communication has properly completed.

Pulse output burnout setting

To set the output direction of pulse output at critical failure, proceed as follows:

1. From online menu,
Select:
 1. Device setup
 - 4. Detailed setup
 - 2. Conf output
 - 2. Pulse output
 - 5. Burn out pls

Figure 7-39 will then be displayed.

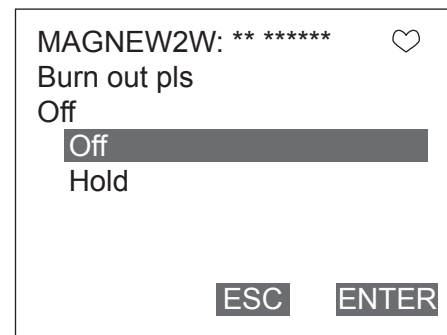

Figure 7-39

2. Once the display as shown in Figure 7-39 appears, move the arrow key up or down to select Off or Hold. After making a selection, press F4 (ENTER). If F3 (ESC) is pressed here, the selection will be canceled and the display will return to the Pulse output menu.
3. After returning to the Pulse output menu, press F2 (SEND). Changed setting will be transmitted to the converter. The HART communicator mark will appear on the upper right hand corner while HART is communicating with the device. The mark will disappear once communication has properly completed.

7-3 : Calibrating and Inspecting the device by HART Communicator and other functions

7-3-1 : Device adjustment

Analog current output adjustment

To adjust analog output (4 mA and 20 mA) adjustment, proceed as follows:

1. From online menu,
Select:
1. Device setup
→ 2. Diag/Service
→ 3. Calibration
→ 1. D/O trim

Figure 7-40 will then be displayed.
If the control system is not affected by the forcible change of the current signal, press F4 (OK). By pressing F3 (ABORT), the procedure is canceled.

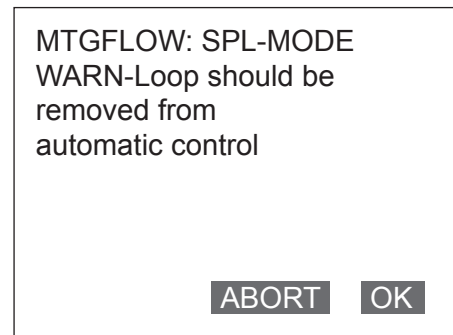

Figure 7-40

2. Once the display as shown in Figure 7-41 appears, move the arrow key up or down to select a current output to adjust, and then press F4 (ENTER). This time, select 4 mA.

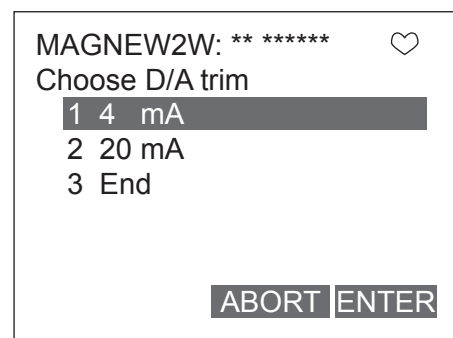

Figure 7-41

3. Figure 7-42 will then appear. Connect the device to measure the current output, and then press F4 (OK).

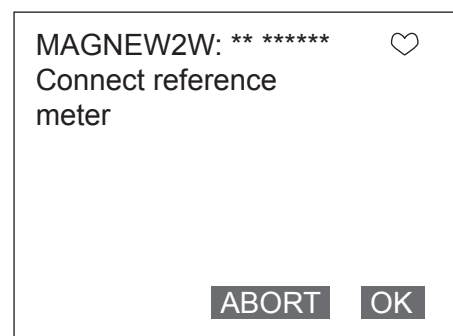

Figure 7-42

4. Figure 7-43 will then appear. By pressing F4 (OK), current adjustment will start and the converter will output a current corresponding to 0% of the flow range. If it is fine, press F4(OK)

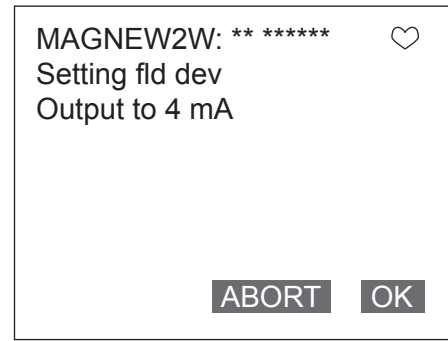

Figure 7-43

5. Figure 7-44 will then appear. When executing the adjustment, select “SET”, and then press F4 (ENTER).

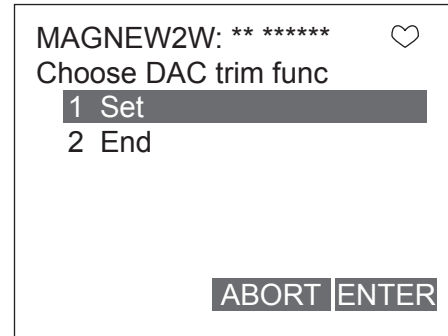

Figure 7-44

6. A numerical value input display (Figure 7-45) will then appear. Measure the output current from the converter and enter the current value by the mA into the device. Once the input has been completed press F4 (ENTER). The converter will start adjusting to 4mA automatically, and return back to the display as shown in Figure 7-44. Verify that the current output value is 4 mA, and terminate the adjustment.

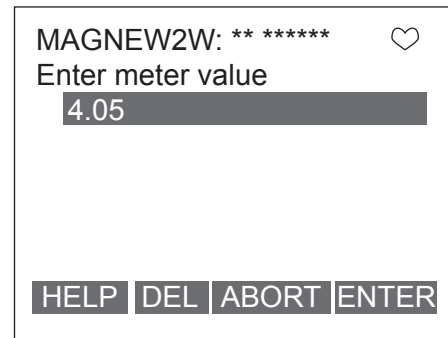

Figure 7-45

7. For 20 mA current output adjustment, follow the same procedures as shown in above.

Gain adjustment

To adjust gain, proceed as follows:

1. From online menu,
Select:
 1. Device setup
 - 2. Diag/Service
 - 3. Calibration
 - 3. Gain trim

Figure 7-46 will then be displayed.

If the control system is not affected by the forcible change of the current signal, press F4 (OK). By pressing F3 (ABORT), the procedure is canceled.

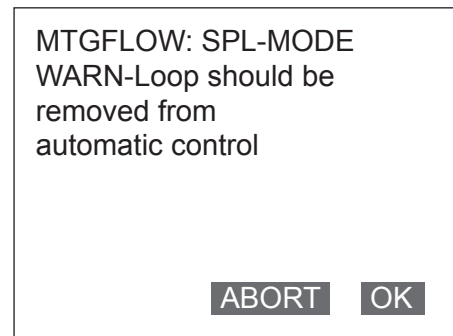

Figure 7-46

2. Figure 7-47 will then appears. Connect the calibrator, and then press F4 (OK).

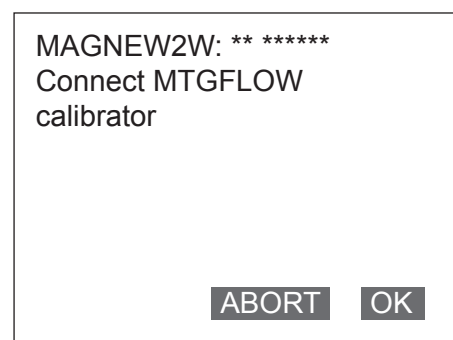

Figure 7-47

3. Once the display as shown in Figure 7-48 appears, move the arrow key up or down to select a gain to adjust, and then press F4 (ENTER). This time, select 0 m/s.

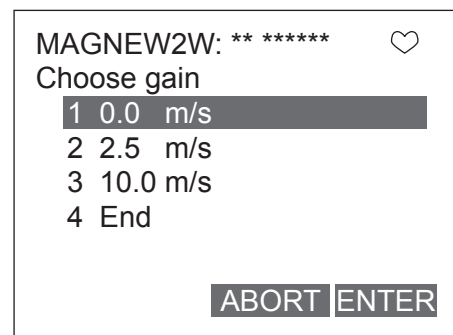

Figure 7-48

4. Figure 7-49 will then appear. Set the connected calibrator value to 0.0 m/s and then press F4 (OK).

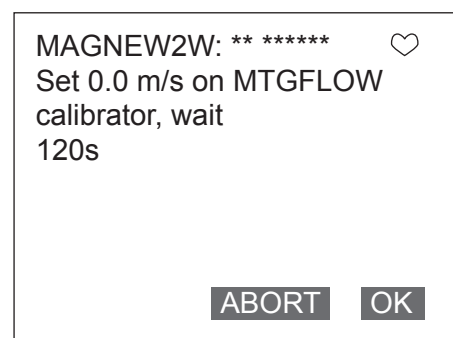

Figure 7-49

- 5. Figure 7-50 will then appear. When executing the adjustment, press F4 (ENTER) to start the adjustment.

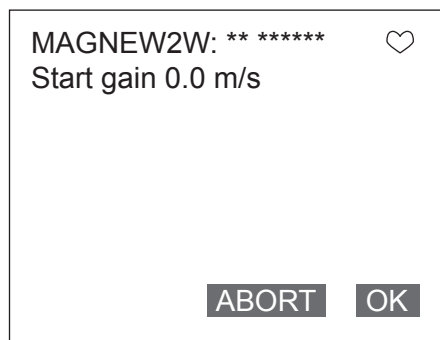

Figure 7-50

- 6. Figure 7-51 will then appear. Please wait until the adjustment completes.

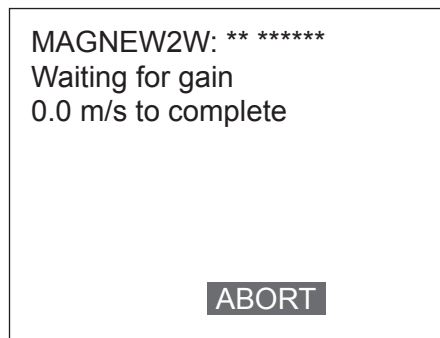

Figure 7-51

- 7. After the gain adjustment has been completed, display shown in Figure 7-52 appears. Gain adjustment of 0.0 m/s is now completed. For gain adjustment of 2.5 m/s and 10 m/s, follow the same procedures as shown in above.



Figure 7-52

Pulse output adjustment

To adjust the pulse output, proceed as follows:

1. From online menu,
Select:
 1. Device setup
 - 2. Diag/Service
 - 3. Calibration
 - 4. Pulse trim

Figure 7-53 will then be displayed.

If the control system is not affected by the forcible change of the current signal, press F4 (OK). By pressing F3 (ABORT), the procedure is canceled.

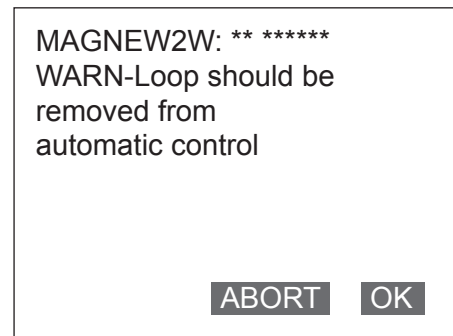

Figure 7-53

2. Figure 7-54 will then appears. Connect the device to measure the pulse output, and then press F4 (OK).

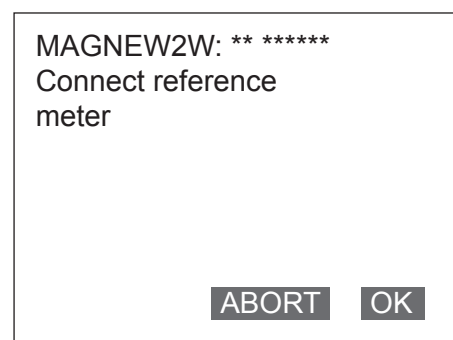

Figure 7-54

3. Figure 7-55 will then appear. By pressing F4 (OK), the pulse output adjustment will start and the converter will output a pulse of 90 Hz. If it is fine, press F4 (OK).



Figure 7-55

4. Figure 7-56 will then appear. When executing the adjustment, select "SET", and then press F4 (ENTER).

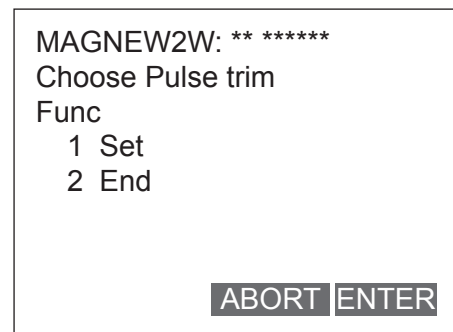

Figure 7-56

5. A numerical value input display (Figure 7-57) will then appear. Measure the pulse frequency from the converter and enter the frequency by the Hz into the device. Once the input has been completed press F4 (ENTER). The converter will start adjusting to 90 Hz automatically, and return back to the display as shown in Figure 7-56. Verify that the pulse output is 90Hz, and terminate the adjustment.

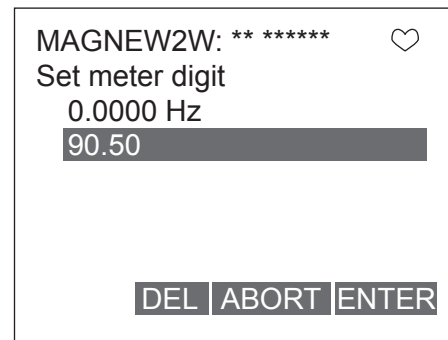

Figure 7-57

Excitation current adjustment

To adjust the excitation current adjustment, proceed as follow:

1. From online menu,
Select:
 1. Device setup
 - 2. Diag/Service
 - 3. Calibration
 - 5. Ex current trim

Figure 7-58 will then be displayed.

If the control system is not affected by the forcible change of the current signal, press F4 (OK). By pressing F3 (ABORT), the procedure is canceled.

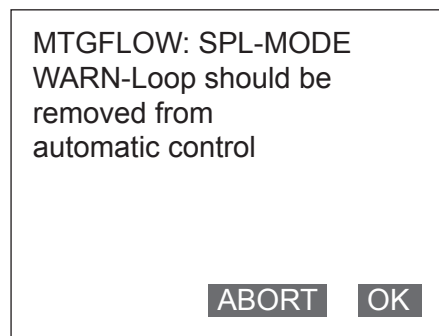

Figure 7-58

2. Once the display as shown in Figure 7-59 appears, move the arrow key up or down to select an excitation current to adjust, and then press F4 (ENTER). This time, select 3.5 mA.

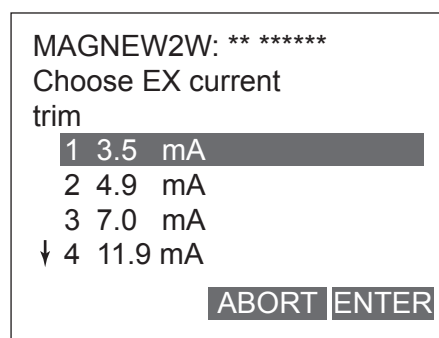

Figure 7-59

3. Figure 7-60 will then appears. Connect the device to measure excitation current to the both ends of the excitation check pin and then press F4 (OK).

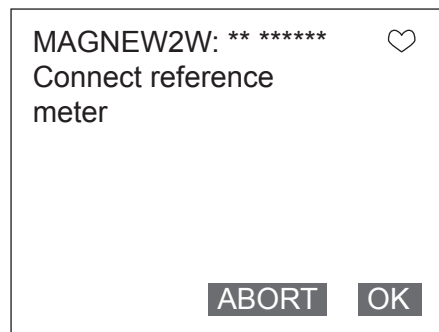

Figure 7-60

4. Figure 7-61 will then appear. By pressing F4 (OK), excitation current adjustment starts, and the converter will adjust the excitation current to 3.5 mA. If it is fine, press F4 (OK).



Figure 7-61

5. Figure 7-62 will appear. When executing the adjustment, choose “SET” and press F4 (ENTER).

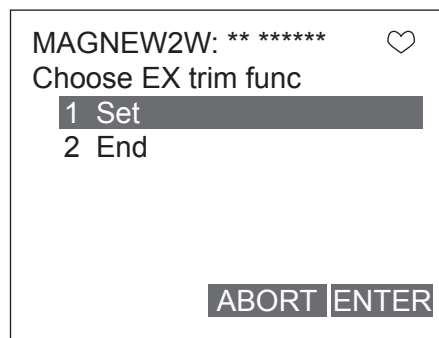

Figure 7-62

6. A numerical value input display (Figure 7-63) will then appear. Resistance of 10ohm is in between the check pin. Therefore, when the excitation current is 3.5 mA, approx. 35 mV will be output. Measure this value, and input the value by the mV directly. Press F4 (ENTER). The converter will start adjusting to 3.5 mA automatically, and return back to the display as shown in Figure 7-62. Verify that the excitation current value is 3.5 mA, and terminate the adjustment.

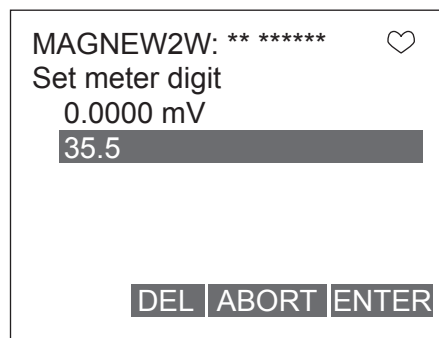

Figure 7-63

7. For the other excitation current adjustment, follow the same procedure as shown in above.

7-3-2 : Output check

Analog output check

To output fixed value of analog current, proceed as follows:

1. From online menu,
Select:
 1. Device setup
 - 2. Diag/Service
 - 2. Loop test
 - 1. Out put check AO
 Figure 7-64 will then be displayed.
 If the control system is not affected by the forcible change of the current signal, press F4 (OK). By pressing F3 (ABORT), the procedure is canceled.
2. Figure 7-65 will then appear. Choose START to start fixed value of analog current output, and then press F4 (ENTER)
3. Note of caution will appear as shown in Figure 7-66. To proceed, press F4 (OK).
4. Use the numeric keys to enter a fixed value to be output in the value input display. Setting range is duty ratio of 0% to +100%. When value is entered, press F4 (ENTER). Analog current corresponding to its output will be output. Press F3 (ABORT) to return to the previous menu.

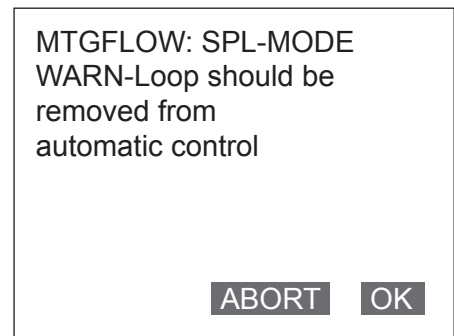

Figure 7-64

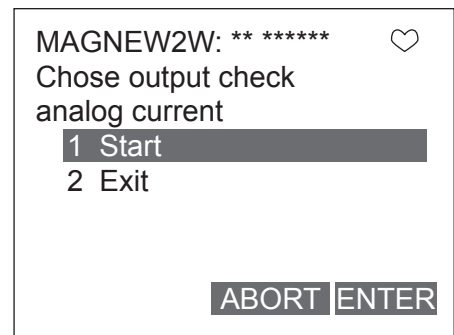

Figure 7-65

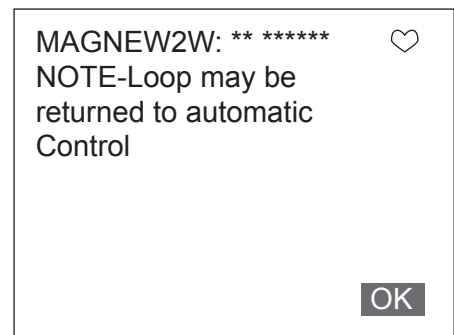

Figure 7-66

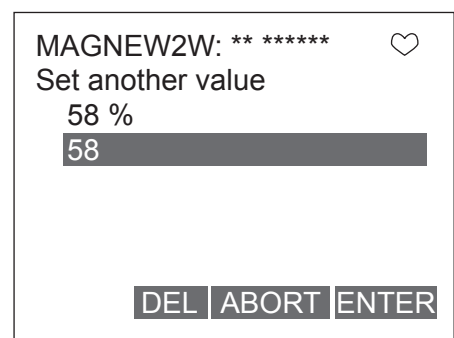

Figure 7-67

Pulse output check

To output pulse fixed value, proceed as follow:

1. From online menu,
Select:
 1. Device setup
→ 2. Diag/Service
→ 2. Loop test
→ 2. Out put check Pls
 Figure 7-68 will then be displayed.
If the control system is not affected by the forcible change of the current signal, press F4(OK). By pressing F3(ABORT), the procedure is canceled.

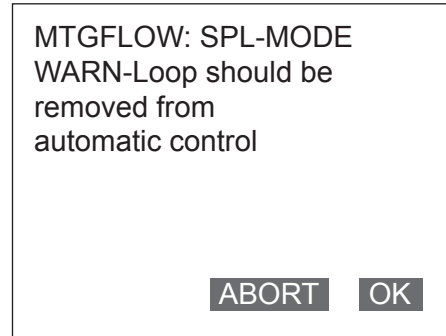

Figure 7-68

2. Figure 7-69 will then appear. Choose START to start fixed value of pulse output, and then press F4(ENTER)

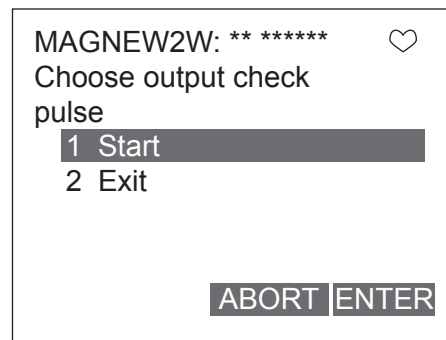

Figure 7-69

3. Note of caution will appear as shown in Figure 7-70. To proceed, press F4(OK).

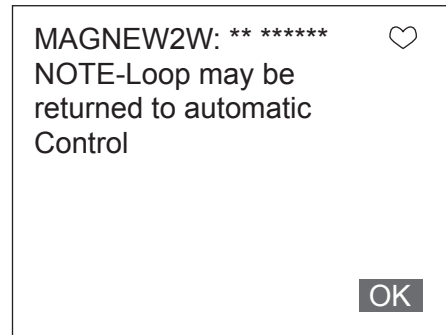

Figure 7-70

4. Use the numeric keys to enter a fixed value to be output in the value input display. Setting range is duty ratio of 0% to +100%. When value is entered, press F4 (ENTER). Pulse corresponding to its output will be output. Press F3 (ABORT) to return to the previous menu.

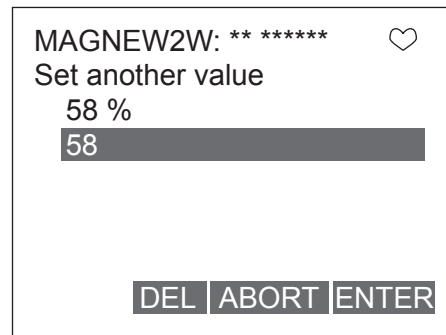

Figure 7-71

Contact output check

To output contact fixed value, proceed as follows:

1. From online menu,
Select:
 1. Device setup
 - 2. Diag/Service
 - 2. Loop test
 - 3. Out put check Do
 Figure 7-72 will then be displayed.
 If the control system is not affected by the forcible change of the current signal, press F4 (OK). By pressing F3 (ABORT), the procedure is canceled.

2. Figure 7-73 will then appear. Choose START to start fixed value of contact output, and then press F4 (ENTER)

3. Figure 7-74 will appear. Move the arrow key up or down to select an OPEN or CLOSE. After making a selection, press F4 (ENTER). Selected contact will be output. Press F3 (ABORT) to return to the previous menu.

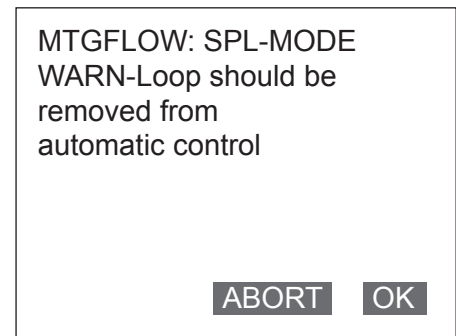

Figure 7-72

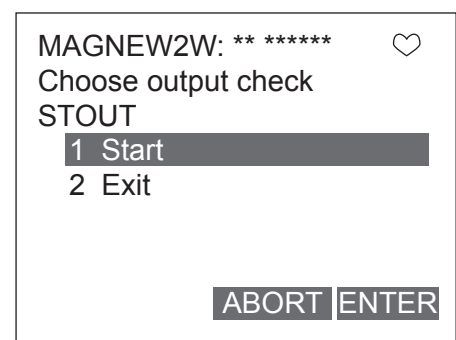

Figure 7-73

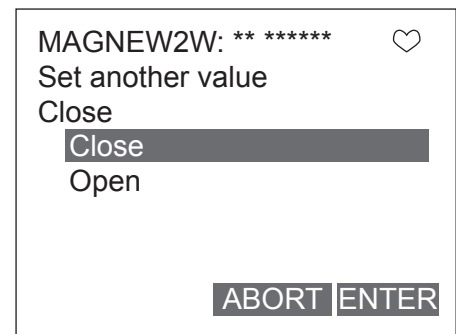

Figure 7-74

7-3-3 : Other functions

Verifying status of converter

To verify the status and setting of the device, proceed as follow:

1. From online menu,
Select:
 1. Device setup
 - 2. Diag/Service
 - 1. Device Status
 Figure 7-75 will then be displayed.

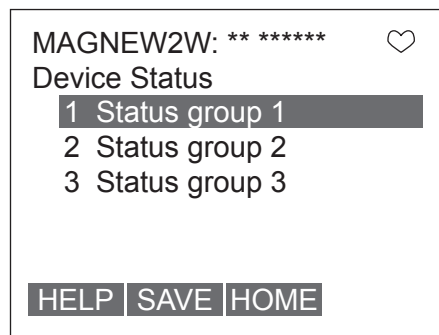

Figure 7-75

2. There are 3 groups. Each group has different items to be verified. Figure 7-76 shows an example of “status group 1”.

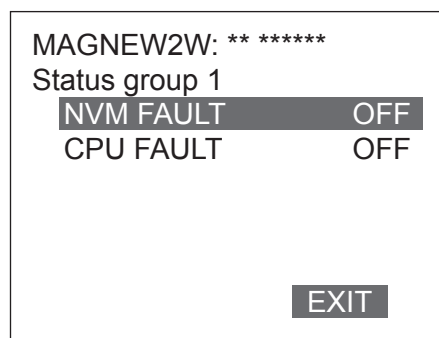

Figure 7-76

3. Table 7-1 shows the items to be verified in each group.

Table 7-1 Items in each group

Group	Item	Description
Group 1	NVM FAULT	Abnormal non-volatile memory
	CPU FAULT	Abnormal CPU
Group 2	IN LOCAL MODE OFF	Changing the setting from display
	DO OUTPUT MODE OFF	Checking the contact output
	PLS OUTPUT MODE OFF	Checking the pulse output
	AO OUTPUT MODE	Checking the analog output
	IN CALIB MODE	Adjusting
	NOT CALIBRATED	Non adjusted
	EX OUTPUT MODE	Checking the excitation current
Group 3	HI<LO ALM ERROR	Abnormal high/Low alarm setting
	SPAN OVER ERROR	Span gone beyond its high limit
	PLS SCALE ERROR	Pulse scale setting error
	PLS WIDTH ERROR	Pulse width setting error

Tag setting

To set the tag, proceed as follow:

1. From online menu,
Select:
1. Device setup
→ 3. Basic setup
→ 1. Tag
Figure 7-77 will then be displayed.

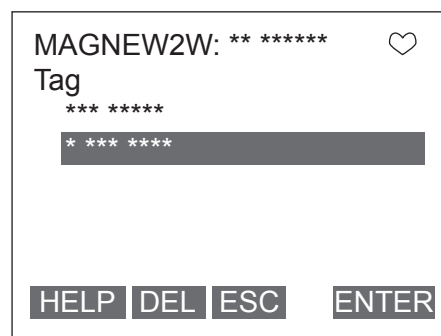

Figure 7-77

2. Once the display as shown in Figure 7-77 appears, use the arrow key up, down, right or left and numerical keys to enter the number. After entering, press F4 (ENTER). If F3 (ESC) is pressed here, the selection will be canceled and the display will return to the Basic setup menu.
3. After returning to the Basic setup menu, press F2 (SEND). Changed setting will be transmitted to the converter.

Shipping data recovery

Follow the procedure described below to execute the shipping data recovery. Please make sure that when it is executed, the internal data will return to the factory setting.

1. From online menu,
Select:
1. Device setup
→ 2. Diag/Service
→ 3. Calibration
→ 6. Shipping RCVR
Figure 7-78 will then be displayed.

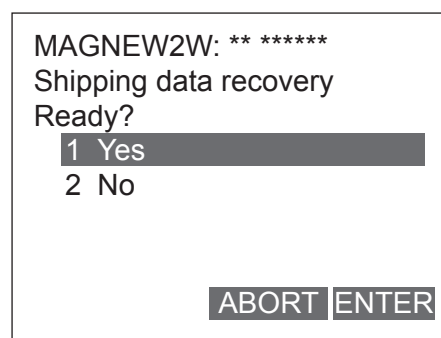

Figure 7-78

2. When executing shipping data recovery, select “YES” and press F4 (ENTER). Shipping data recovery will execute, and the display will return to Figure 7-78. Press F3(ABORT) to return to the previous menu.

Review

1. From online menu,
 Select:
 1. Device setup → 5. Review
 Then, the status of the device can be confirmed (see Figure 7-79). Use F2 (PREV)
 and F3 (NEXT) to move the confirming items.

Review	
Model	MTGFLOW
Distributor	Yamatake Corporation
PV unit	m3/h
PV URV	m3/h
PV LRV	0.00 m3/h
PV USL	84.82 m3/h
PV LSL	0.00 m3/h
PV Min span	0.00000 m3/h
Xfer fctn	Linear
Lo flo cutoff	2 %
Tube size	50 A
Pulse scaling	27.77637 cm3/P
Pulse Width	30 ms
PV Damp	3.0 s
AO Alrm typ	Lo
Write protect	No
Manufacturer	Yamatake Corporation
Dev id	0
Tag	SPL-MODE
Descriptor	XXXXXXXXXXXXXXXXXXXX
Message	XX
Universal rev	5
Fld dev rev	1
Software rev	3.0
Poll addr	0
Num req preams	5
Final asmbly num	0

Figure 7-79

7-4 : Short cut commands and menus for HART communicator

7-4-1 : Short cut keys

Select the item to set from the table below, and press the item number from the online menu. You can move to the item, which you want to set quickly.

Basic setting	
Flow unit	132
Range	133
Specific gravity	134
Damping time constant	135
Auto zero	136
Display selection	137
Function selection	138
Correction coefficient	139
Communication method	1426

Detector setting	
Detector diameter	1411
Detector type	1412
Detector constant	1413

Signal processing	
Auto spike cut	1432
Moving average processing	1433
Moving average processing time	1434
Low flow cut	1435
Drop-out	1436

Pulse setting	
Pulse scale unit	14221
Pulse scale	14222
Pulse width	14223

Totalized value setting	
Totalized value display	14231
Totalized reset value	14232
Totalized value reset	14233

Emergency setting	
High alarm value setting	14241
Low alarm value setting	14242
Contact output status setting	14243
Burnout (Analog output)	14215
Burnout (Pulse output)	14225

Device adjustment	
Analog current output adjustment	1231
Gain adjustment	1233
Pulse output adjustment	1234
Excitation current adjustment	1235

Output inspection	
Analog output check	1221
Pulse output check	1222
Contact output check	1223

Others	
Converter status	121
ID setting	131
Shipping data recovery	1236
Review	15

7-4-2 : Menu tree

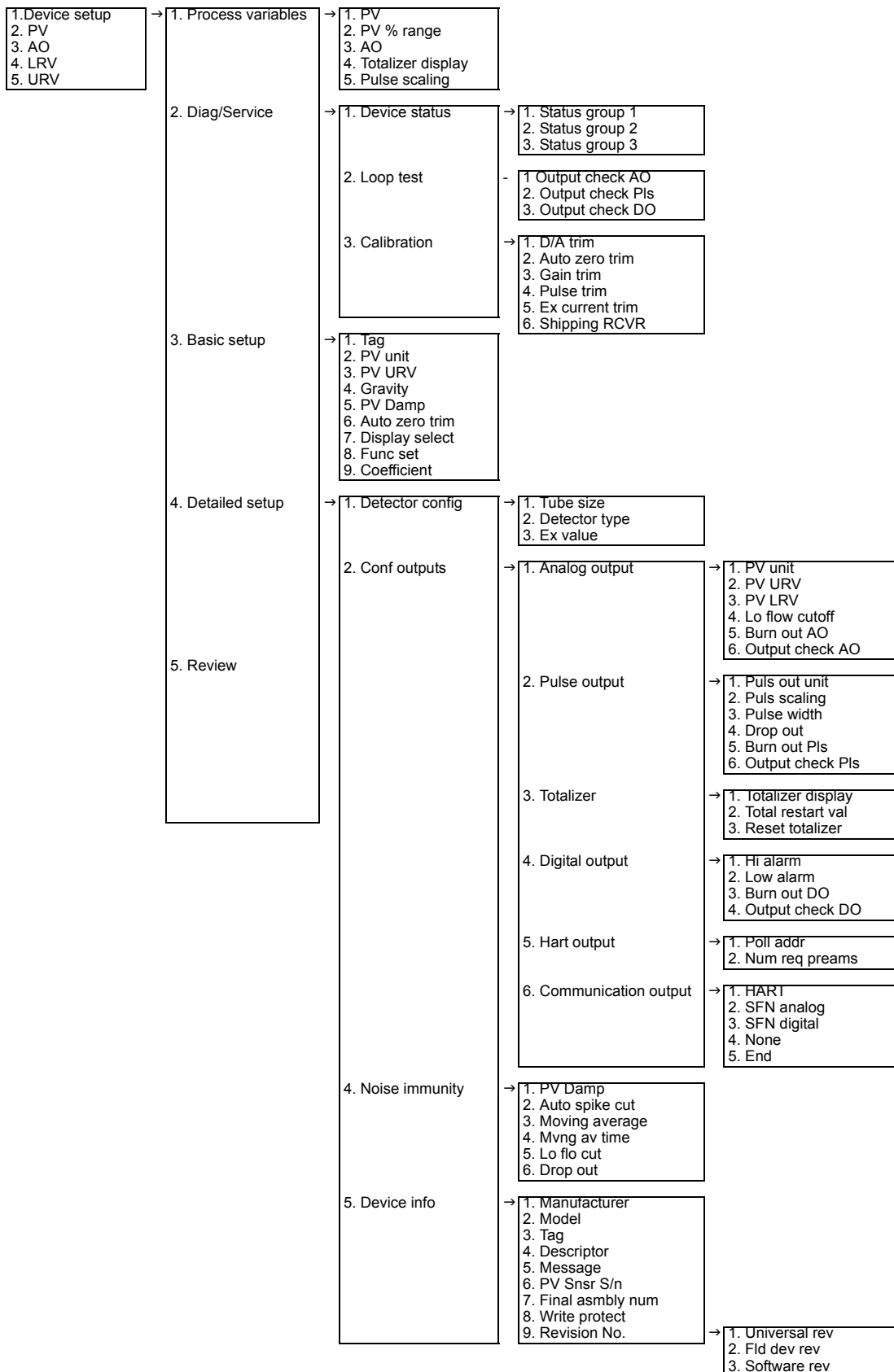

Chapter 8 : Maintenance and troubleshooting

Outline of this chapter

This chapter presents the instrument maintenance and maintenance procedure and information to be referred for troubleshooting. Ensure the procedure for maintenance based on the trouble.

8-1 : Maintenance and inspection of parts

Replacement of indicator / data setting device

Procedure

Replacement procedure is as follows.

Step	Procedure
1	Power off the converter by circuit breaker etc.
2	The converter front cover is fixed by hexagon socket head screws (M3). Loosen these screws with an Allen wrench (1.5).
3	Remove the converter front cover by turning it counterclockwise with the dedicated tool. ~Note <i>Remove the front cover straight and with care.</i>
4	Remove the 3 fixing screws.
5	Remove by pulling out.
6	Align the new card's connector to the converter connector. ~Note <i>Ensure the correct panel direction. The panel attaching direction can be chosen from two options according to the attaching position of this instrument.</i>
7	Fix the card again with the 3 screws. ~Note <i>The connector is connected firmly by tightening the screws.</i>
8	Attach the front cover. ~Note <i>Take care not to injure your fingers on the cover edge or the thread in the case.</i>

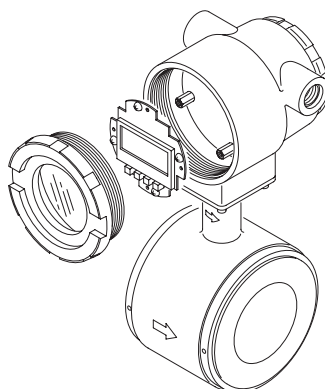

Figure 8-1 Replacement of indicator/data setting device (with the cover removed)

~Note *When unpacking the detector, do not open the packing in the location with high temperature and humidity, many dust and corrosive gas atmosphere.*

8-2 : Troubleshooting

Types of troubles

Introduction

If a problem occurs at the instrument start-up and operation, the following three causes should be considered.

- Inconsistency between the specifications and actual operating conditions.
- Missetting or misoperation.
- Instrument malfunction.

If a problem occurs during operation, the device's self-diagnostic function will classify it as critical or non-critical. It will indicate this and respond accordingly.

Critical failure

Critical problems may obstruct electromagnetic flowmeter operation, if not corrected, ultimately damage the flowmeter. When critical problem occurs during operation, an error message will appear on the converter's display panel and the output continues to output the value set in the direction of abnormality processing. The error message and self-diagnosis results can be read through communication (SFC, HART communicator).

Non-critical failure

Non-critical problems will not seriously affect electromagnetic flowmeter operation. When an error occurs during operation and is regarded as a non-critical problem by the converter self-diagnostics, the output will not burn-out and the flowmeter will continue to output the measured value.

Troubles at startup

Troubleshooting

When a problem occurs at start-up, perform the following procedures. If the problem remains, it is possible that the device has been damaged. Contact your local Yamatake representative.

Trouble	Check point and troubleshooting
No indication on display panel when powered on.	<ul style="list-style-type: none"> • Check the specifications of the power source. • Check the wiring. • Check if the ambient temperature is not under -4°F (-20°C).
No output when powered on.	<ul style="list-style-type: none"> • Check the signal line for correct connection.
Communication failure.	<ul style="list-style-type: none"> • Check the signal line for correct connection. A load resistance of 250 Ω or more is required (SFC). • Check the communicator for correct connection. (SFC has polarity.) • SFC of Version 7.0 or later is used. Operation is impossible with a lower version. • Is model MTG DD (device description) downloaded on the HART Communicator? The DD for the model MTG should be downloaded from HCF DD Library Host DD Distribution (HCF-KIT-III) Release 2002 Number 3 or later.
No pulse output	<ul style="list-style-type: none"> • Check the counter type, input specifications and contact capacity. • Check the pulse setting of the flowmeter.

Troubles during operation

Troubleshooting

When a problem occurs during operation, perform the following procedures.

1. Search for the symptom of the trouble in the table on this page. If found, perform the steps indicated in the table.
2. If communication is possible, read the error message and self-diagnosis results. Perform referring to “Error messages and troubleshooting”.
3. If the problem can not be solved, it is possible that the device has been damaged. Contact your local Yamatake representative.

Trouble	Check point and troubleshooting
Output fluctuates excessively beyond the estimated flow rate range	<ul style="list-style-type: none"> • Check if the instrument is grounded correctly. • Check if the damping time constant is set correctly. • Clean the electrodes.
Output exceeds 100%.	<ul style="list-style-type: none"> • Check if the range is set correctly. • Check if zero is adjusted correctly.
Output remains 0%	<ul style="list-style-type: none"> • Check if the signal line is connected correctly. • Check the upstream and downstream valves. • Check if the range is set correctly. • Check whether the instrument is set to the constant current mode. • Press the CLR (clear) key on SFC to cancel this mode. • Check if the flow rate is not within the set range of low-flow cutoff. • Check if the flow rate is not reversed (negative flow rate). • Check the detector for unfilled condition, too low conductivity, excessive noise, etc.
Output has burnt out	<ul style="list-style-type: none"> • Take measures referring to “Error messages and measures”.
Pulse output is too large or too small for the calorific value	<ul style="list-style-type: none"> • Is the pulse setting (weight and width) correct? • Is the output from the main unit correct? • Is a pulse counter of appropriate specifications used? • Is the dropout value correctly set between 0 and 10%.

8-3 : Spare parts

8-3-1: Spare parts for integral type

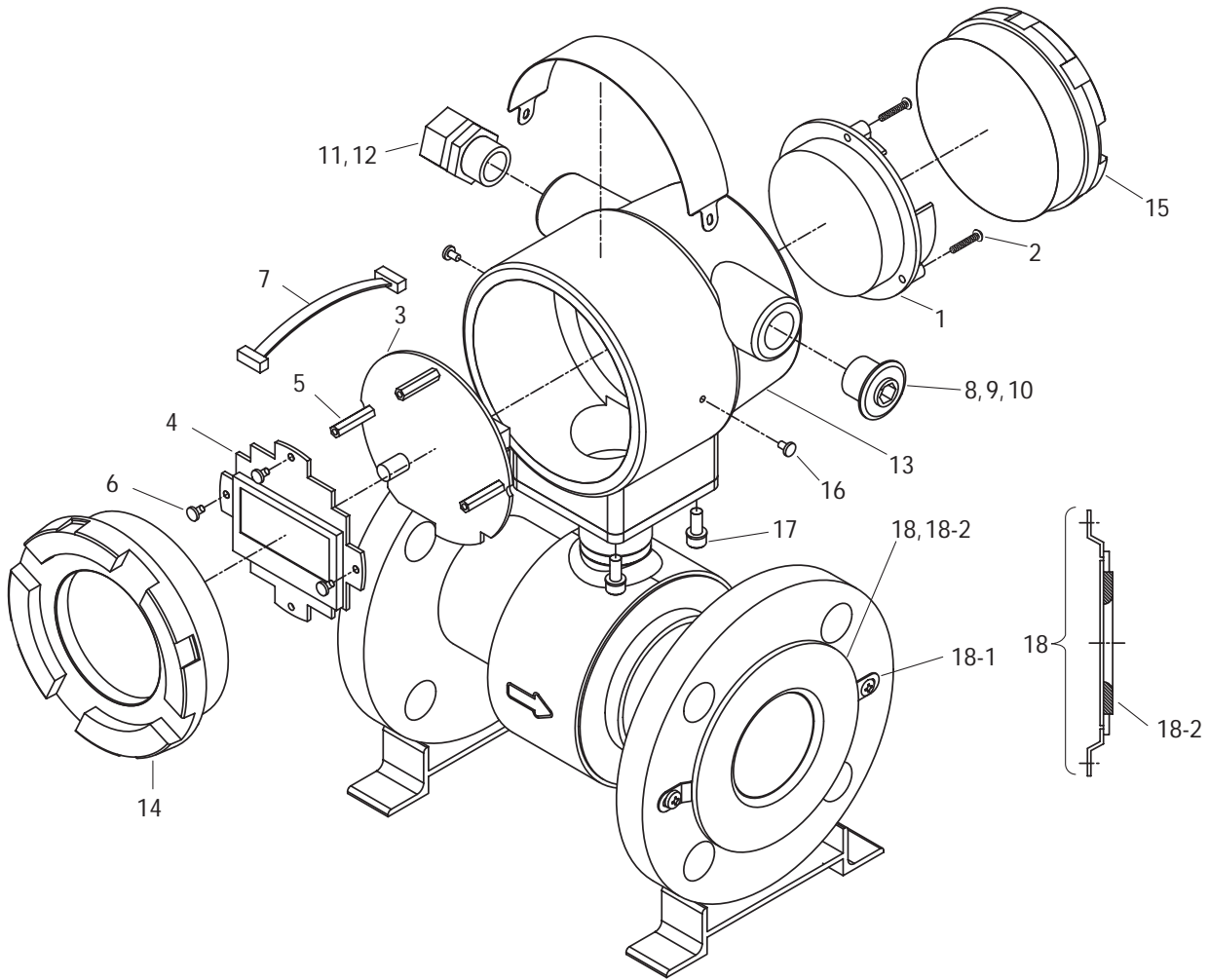

Figure 8-2 Spare parts for integral type

Table 8-1 Spare parts for integral type

No.	Parts number	Parts name
1	80382679-00100	Terminal assembly
2	HS309-230-16000	Screw
3	80382684-00100	Main board
4	80382689-00100	LCD board
5	83958309-00100	Spacers
6	HS311-530-06200	Screw
7	80382637-00100	Main LCD cable assembly
8	80381052-00100	Plug assembly (G1/2)
9	80020810-00600	Plug (1/2NPT)
10	80354400-00100	Plug assembly (CM20)
11	80352997-00100	Plastic gland
12	80356020-10100	Watertight gland assembly (brass Ni plated)
13	80382671-00100	Case (conduit connection G1/2, standard finish)
	80382671-00200	Case (conduit connection 1/2NPT, standard finish)
	80382671-00300	Case (conduit connection CM20, standard finish)
	80382671-00400	Case (conduit connection G1/2, corrosion proof finish)
	80382671-00500	Case (conduit connection 1/2NPT, corrosion proof finish)
	80382671-00600	Case (conduit connection CM20, corrosion proof finish)
14	80382673-00100	Cover assemblies (display) (standard finish)
	80382673-00200	Cover assemblies (display) (corrosion proof finish)
15	80277719-00100	Cover assemblies (terminal) (standard finish)
	80277719-00300	Cover assemblies (terminal) (corrosion proof finish)
16	HS311-230-05000	Screw
17	80356995-00100	Screw
18	Refer to Table 8-4	Wafer type grounding ring assembly
18-1	Refer to Table 8-4	Screw
18-2	Refer to Table 8-4	PTFE gasket for grounding ring other than SUS
18	Refer to Table 8-5	Flange type grounding ring assembly
18-1	Refer to Table 8-5	Screw
18-2	Refer to Table 8-5	PTFE gasket for grounding ring other than SUS

8-3-2: Spare parts for remote type converter

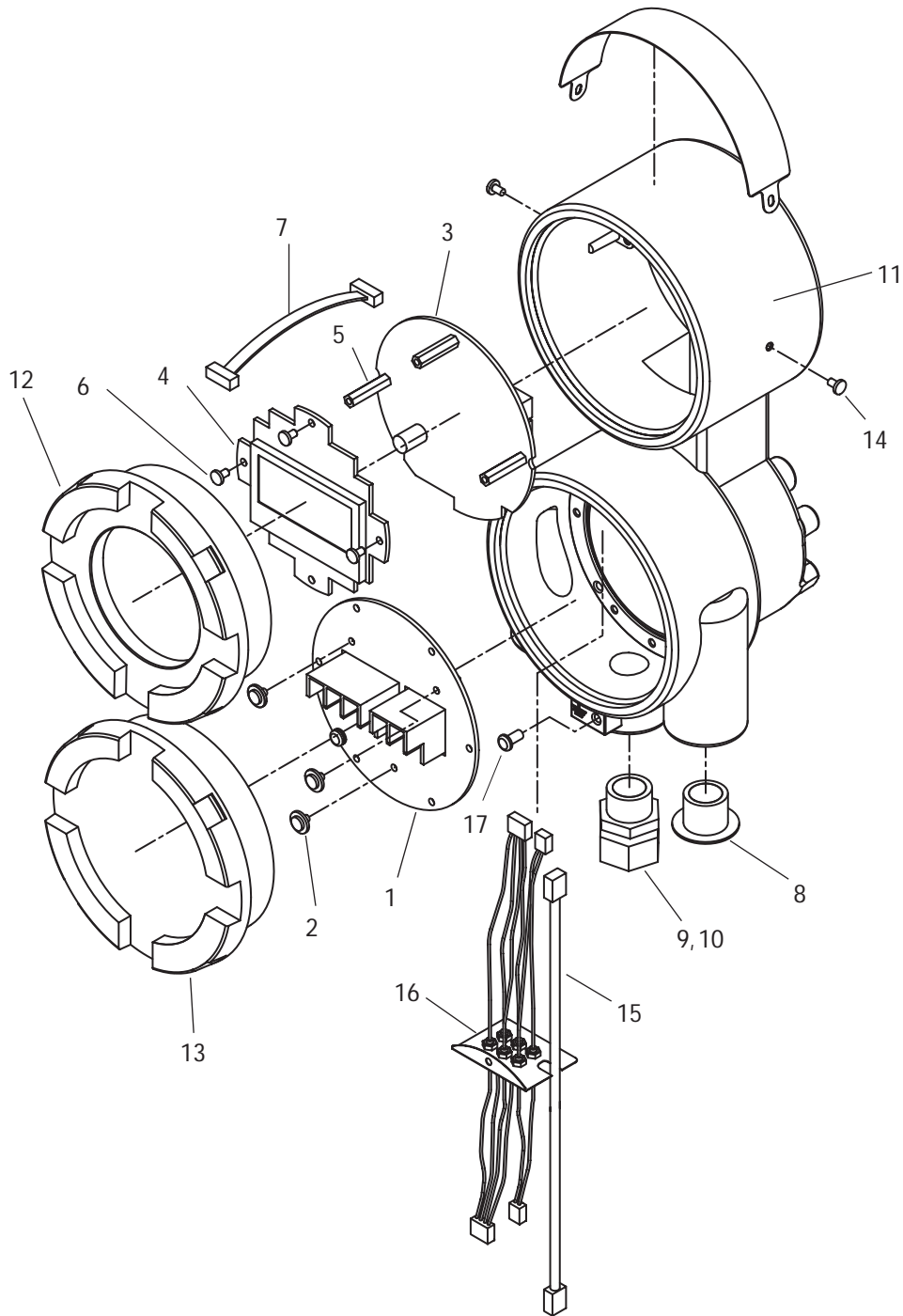

Figure 8-3 Spare parts for remote type converter

Table 8-2 Spare parts for remote-type converter (Model MTG11B)

No.	Parts number	Parts name
1	80382354-00100	Terminal assembly
2	HS309-230-16000	Screw
3	80382684-00100	Main board
4	80382689-00100	LCD board
5	83958309-00100	Spacers
6	HS311-530-06200	Screw
7	80382637-00100	Main LCD cable assembly
8	80381052-00100	Plug assembly (G1/2)
9	80352997-00100	Plastic gland
10	80356020-10100	Watertight gland assembly (brass Ni plated)
11	80382366-00100	Case (conduit connection G1/2, standard finish)
	80382366-00400	Case (conduit connection G1/2, corrosion proof finish)
12	80382673-00100	Cover assemblies (display) (standard finish)
	80382673-00200	Cover assemblies (display) (corrosion proof finish)
13	80382673-00300	Cover assemblies (terminal) (standard finish)
	80382673-00400	Cover assemblies (terminal) (corrosion proof finish)
14	HS311-230-05000	Screw
15	80382358-00100	Signal cable assembly
16	80382372-00100	Shields plate assembly
17	HS398-204-18000	Screw

8-3-3: Spare parts for remote type detector

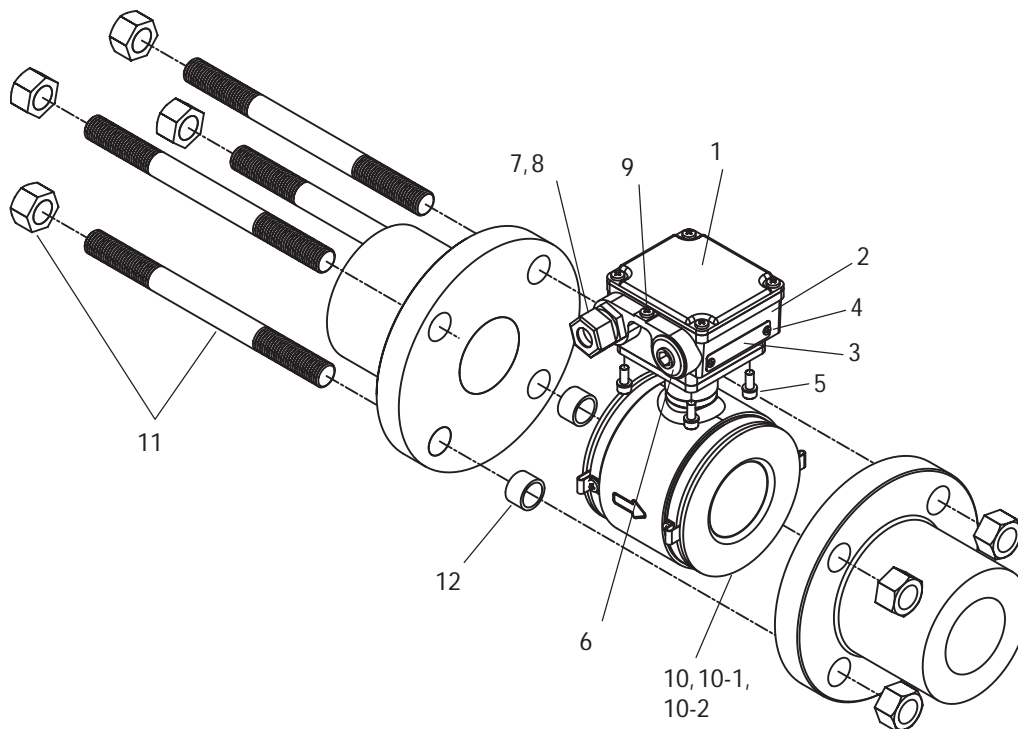

Figure 8-4 Spare parts for remote type detector

Table 8-3 Spare parts for remote-type detector

No.	Parts number	Parts name
1	80380573-00100	Terminal box cover (standard finish)
	80380573-00300	Terminal box cover (corrosion proof finish)
2	80380571-00100	Terminal boxes (conduit connection G1/2, standard finish)
	80380571-00900	Terminal boxes (conduit connection G1/2, corrosion proof finish)
3	80380584-00100	Tag plate
4	HS311-230-05000	Screw
5	80356995-00100	Screw
6	80381052-00100	Plug assembly (G1/2)
7	80352997-00100	Plastic gland
8	80356020-10100	Watertight gland assembly (brass Ni plate)
9	HS311-240-06000	Grounding terminal
10	Refer to Table 8-4	Wafer type grounding ring assembly
10-1	Refer to Table 8-4	Screw
10-2	Refer to Table 8-4	PTFE gasket for grounding ring other than SUS
10	Refer to Table 8-5	Wafer type grounding ring assembly
10-1	Refer to Table 8-5	Screw
10-2	Refer to Table 8-5	PTFE gasket for grounding ring other than SUS
11	Refer to Table 8-6	Through bolt and nut for wafer type detector
12	Refer to Table 8-7	Special centering tool for wafer type detector

Table 8-4 Wafer type grounding ring assembly

Grounding ring material	Diameter (mm)	Parts number	Qty.	Parts number	Qty.
SUS316	2.5/5	80380639-00100	1	HS314203-05000	1
	10	80380639-00200	1	HS314203-05000	1
	15	80380639-00300	1	HS314203-05000	1
	25	80380640-00100	1	HS314203-05000	1
	40	80380641-00100	1	HS311230-06000	1
	50	80380641-00200	1	HS311230-06000	1
	65	80380641-00300	1	HS311230-06000	1
	80	80380641-00400	1	HS311240-06000	1
	100	80380641-00500	1	HS311240-06000	1
	150	80380641-00700	1	HS311240-06000	1
200	80380641-00800	1	HS311240-06000	1	
ASTM B575 (Hastelloy C-276 equivalent)	2.5/5	80380614-00100	1	HS314203-05000	1
	10	80380615-00100	1	HS314203-05000	1
	15	80380616-00100	1	HS314203-05000	1
	25	80380617-00100	1	HS314203-05000	1
	40	80380618-00100	1	HS311230-06000	1
	50	80380619-00100	1	HS311230-06000	1
	65	80380620-00100	1	HS311230-06000	1
	80	80380621-00100	1	HS311240-06000	1
	100	80380622-00100	1	HS311240-06000	1
	150	80380624-00100	1	HS311240-06000	1
200	80380625-00100	1	HS311240-06000	1	
Titanium	2.5/5	80380614-00200	1	HS314203-05000	1
	10	80380615-00200	1	HS314203-05000	1
	15	80380616-00200	1	HS314203-05000	1
	25	80380617-00200	1	HS314203-05000	1
	40	80380618-00200	1	HS311230-06000	1
	50	80380619-00200	1	HS311230-06000	1
	65	80380620-00200	1	HS311230-06000	1
	80	80380621-00200	1	HS311240-06000	1
	100	80380622-00200	1	HS311240-06000	1
	150	80380624-00200	1	HS311240-06000	1
200	80380625-00200	1	HS311240-06000	1	
Zirconium	2.5/5	80380614-00700	1	HS314203-05000	1
	10	80380615-00700	1	HS314203-05000	1
	15	80380616-00700	1	HS314203-05000	1
	25	80380617-00700	1	HS314203-05000	1
	40	80380618-00700	1	HS311230-06000	1
	50	80380619-00700	1	HS311230-06000	1
	65	80380620-00700	1	HS311230-06000	1
	80	80380621-00700	1	HS311240-06000	1
	100	80380622-00700	1	HS311240-06000	1
	150	80380624-00700	1	HS311240-06000	1
200	80380625-00700	1	HS311240-06000	1	

Table 8-4 Wafer type grounding ring assembly

Grounding ring material	Diameter (mm)	Parts number	Qty.	Parts number	Qty.
Tantalum	2.5/5	80380614-00300	1	HS314203-05000	1
	10	80380615-00300	1	HS314203-05000	1
	15	80380616-00300	1	HS314203-05000	1
	25	80380617-00300	1	HS314203-05000	1
	40	80380618-00300	1	HS311230-06000	1
	50	80380619-00300	1	HS311230-06000	1
	65	80380620-00300	1	HS311230-06000	1
	80	80380621-00300	1	HS311240-06000	1
	100	80380622-00300	1	HS311240-06000	1
	150	80380624-00300	1	HS311240-06000	1
	200	80380625-00300	1	HS311240-06000	1
Platinum	2.5/5	80380614-00400	1	HS314203-05000	1
	10	80380615-00400	1	HS314203-05000	1
	15	80380616-00400	1	HS314203-05000	1
	25	80380617-00400	1	HS314203-05000	1
	40	80380618-00400	1	HS311230-06000	1
	50	80380619-00400	1	HS311230-06000	1
	65	80380620-00400	1	HS311230-06000	1
	80	80380621-00400	1	HS311240-06000	1
	100	80380622-00400	1	HS311240-06000	1
	150	80380624-00400	1	HS311240-06000	1
	200	80380625-00400	1	HS311240-06000	1

Gasket	Diameter (mm)	Parts number	Qty.
PTFE	2.5/5	80380613-00100	1
	10	80380613-00200	1
	15	80380613-00300	1
	25	80380613-00400	1
	40	80380613-00500	1
	50	80380613-00600	1
	65	80380613-00700	1
	80	80380613-00800	1
	100	80380613-00900	1
	150	80380613-01100	1
	200	80380613-01200	1

Table 8-5 Flange type grounding ring assembly

Grounding ring material	Diameter (mm)	Parts number	Qty.	Parts number	Qty.
SUS316	2.5/5	80380151-00100	1	HS311240-06000	1
	10	80380151-00200	1	HS311240-06000	1
	15	80380151-00300	1	HS311240-06000	1
	25	80380648-00900	1	HS311240-06000	1
	40	80380648-00100	1	HS311240-06000	1
	50	80380648-00200	1	HS311240-06000	1
	65	80380648-00300	1	HS311240-06000	1
	80	80380648-00400	1	HS311240-06000	1
	100	80380648-00500	1	HS311240-06000	1
	150	80380648-00700	1	HS311240-06000	1
ASTM B575 (Hastelloy C-276 equivalent)	2.5/5	80380152-00100	1	HS311240-06000	1
	10	80380152-00200	1	HS311240-06000	1
	15	80380152-00300	1	HS311240-06000	1
	25	80380630-00100	1	HS311240-06000	1
	40	80380631-00100	1	HS311240-06000	1
	50	80380632-00100	1	HS311240-06000	1
	65	80380633-00100	1	HS311240-06000	1
	80	80380634-00100	1	HS311240-06000	1
	100	80380635-00100	1	HS311240-06000	1
	150	80380637-00100	1	HS311240-06000	1
Titanium	2.5/5	80380152-30100	1	HS311240-06000	1
	10	80380152-30200	1	HS311240-06000	1
	15	80380152-30300	1	HS311240-06000	1
	25	80380630-00200	1	HS311240-06000	1
	40	80380631-00200	1	HS311240-06000	1
	50	80380632-00200	1	HS311240-06000	1
	65	80380633-00200	1	HS311240-06000	1
	80	80380634-00200	1	HS311240-06000	1
	100	80380635-00200	1	HS311240-06000	1
	150	80380637-00200	1	HS311240-06000	1
Zirconium	2.5/5	80380751-10100	1	HS311240-06000	1
	10	80380751-10200	1	HS311240-06000	1
	15	80380751-10300	1	HS311240-06000	1
	25	80380630-00700	1	HS311240-06000	1
	40	80380631-00700	1	HS311240-06000	1
	50	80380632-00700	1	HS311240-06000	1
	65	80380633-00700	1	HS311240-06000	1
	80	80380634-00700	1	HS311240-06000	1
	100	80380635-00700	1	HS311240-06000	1
	150	80380637-00700	1	HS311240-06000	1
200	80380638-00700	1	HS311240-06000	1	

Table 8-5 Flange type grounding ring assembly

Grounding ring material	Diameter (mm)	Parts number	Qty.	Parts number	Qty.
Tantalum	2.5/5	80380152-10100	1	HS311240-06000	1
	10	80380152-10200	1	HS311240-06000	1
	15	80380152-10300	1	HS311240-06000	1
	25	80380630-00300	1	HS311240-06000	1
	40	80380631-00300	1	HS311240-06000	1
	50	80380632-00300	1	HS311240-06000	1
	65	80380633-00300	1	HS311240-06000	1
	80	80380634-00300	1	HS311240-06000	1
	100	80380635-00300	1	HS311240-06000	1
	150	80380637-00300	1	HS311240-06000	1
	200	80380638-00300	1	HS311240-06000	1
Platinum	2.5/5	80380152-20100	1	HS311240-06000	1
	10	80380152-20200	1	HS311240-06000	1
	15	80380152-20300	1	HS311240-06000	1
	25	80380630-00400	1	HS311240-06000	1
	40	80380631-00400	1	HS311240-06000	1
	50	80380632-00400	1	HS311240-06000	1
	65	80380633-00400	1	HS311240-06000	1
	80	80380634-00400	1	HS311240-06000	1
	100	80380635-00400	1	HS311240-06000	1
	150	80380637-00400	1	HS311240-06000	1
	200	80380638-00400	1	HS311240-06000	1

Gasket	Diameter (mm)	Key number (18-2)	Qty.
PTFE	2.5/5	82728099-00100	1
	10	82728099-00200	1
	15	82728099-00300	1
	25	80380613-00400	1
	40	80380613-00500	1
	50	80380613-00600	1
	65	80380613-00700	1
	80	80380613-00800	1
	100	80380613-00900	1
	150	80380613-01100	1
	200	80380613-01200	1

Table 8-6 Through bolt and nut (required 1 set per detector)
Parts number: 80380810-ITEM

ITEM	Diameter (mm)	Flange type	Material
101	25	DIN PN10	SUS304
		DIN PN16	
		DIN PN25	
102	40	JIS 10K	SUS304
		JIS 20K	
		DIN PN10	
		DIN PN16	
		DIN PN25	
	50	JIS 10K	
		DIN PN10	
		DIN PN16	
		DIN PN25	
	65	JIS 10K	
		DIN PN10	
		DIN PN16	
80	JIS G3451 F12		
103	50	JIS 20K	SUS304
		JIS 30K	
	65	JIS 20K	
		DIN PN25	
	80	JIS 10K	
		DIN PN10	
DIN PN16			
104	150	JIS G3451 F12	SUS304
105	25	ANSI 150	SUS304
		JPI 150	
	40	ANSI 150	SUS304
		JPI 150	
106	50	ANSI 150	SUS304
		JPI 150	
	65	ANSI 150	
		JPI 150	
	80	ANSI 150	
		JPI 150	
107	50	ANSI 300	SUS304
		JPI 300	

ITEM	Diameter (mm)	Flange type	Material
108	65	ANSI 300	SUS304
		JPI 300	
	80	ANSI 300	
		JPI 300	
109	100	ANSI 300	SUS304
		JPI 300	
111	25	JIS 10K	SUS304
		JIS 20K	
		JIS 30K	
112	100	JIS G3451 F12	SUS304
114	80	DIN PN25	SUS304
	100	JIS 10K	
		DIN PN10	
		DIN PN16	
116	40	JIS 30K	SUS304
117	65	JIS 30K	SUS304
118	80	JIS 20K	SUS304
		JIS 30K	
	100	JIS 20K	
		DIN PN25	
121	100	JIS 30K	SUS304
128	25	ANSI 300	SUS304
		JPI 300	
129	100	ANSI 150	SUS304
		JPI 150	
130	40	ANSI 300	SUS304
		JPI 300	

**Table 8-7 Centering tool for wafer type detector (required 4 pcs. per detector)
Part number: 80380811-ITEM**

ITEM	Diameter (mm)	Flange type
005	25	ANSI 150
		JPI 150
	40	ANSI 150
		JPI 150
008	50	JIS 10K
		JIS 20K
		ANSI 150
		JPI 150
	65	JIS 10K
		JIS20K
		JIS 10K
009	40	JIS 10K
		JIS 20K
	80	ANSI 150
		JPI 150
010	25	JIS 10K
		JIS 20K
		ANSI 300
		JPI 300
	40	DIN PN10
		DIN PN16
		DIN PN25
	50	DIN PN10
		DIN PN16
		DIN PN25
	65	DIN PN10
		DIN PN16
		DIN PN25
	100	DIN PN10
		DIN PN16
	011	50
JPI 300		
80		DIN PN10
		DIN PN16
		DIN PN25
012	50	JIS 30K
		JIS 30K

ITEM	Diameter (mm)	Flange type
015	80	JIS G3451 F12
	100	JIS G3451 F12
018	65	ANSI 300
		JPI 300
	80	JIS 20K
	100	JIS 20K
019	40	ANSI 300
		JPI 300
	80	JIS 30K
020	100	DIN PN25
		DIN PN40
021	40	JIS 30K
022	65	JIS 30K
025	100	JIS 30K
033	25	DIN PN10
		DIN PN16
		DIN PN25
035	65	ANSI 150
		JPI 150

Document Number: CM2-MTG100-2001

Document Name: MagneW Neo / MagneW Two-sire PLUS
Smart Two-wire Electromagnetic Flowmeter
Model: MTG11A / 18A, 11B/18B, 14C
User's Manual

Date: Jan. 2002 (First issue)
Jan. 2005 (Rev. 5)

Issued/Edited by: Yamatake Corporation

Yamatake Corporation

Totate international Building
2-12-19 Shibuya
Shibuya-ku, Tokyo 150-8316
Japan

Tel : 81-3-3486-2310

Fax : 81-3-3486-2593

YAMATAKE

Savemation

Saving through Automation