

The Elliptical-Tube Flowmeter
Measurement Accuracy
for the
Surest Income



Yamatake Corporation

Question

Do you think the orifice is the best flowmeter to measure your gas?



Please decide your attitude after we have introduced the **E-Tube Flowmeter**

Yamatake's Elliptical-Tube Flowmeter

consists of,

Primary Element

The E-Tube

For stable differential pressure and minimum pressure loss.



Secondary Element



The Multivariable Transmitter

For accurate measurement of differential pressure, static pressure, and temperature, as well as calculation of flow rate.

Contents

1. Problem with the Orifice in Gas Wells
2. Solution with the E-Tube
3. Competitive Advantages
4. Summary
5. Yamatake: Corporate Profile

Contents

1. Problem with the Orifice in Gas Wells

1.1 Gas wells contain sand and rust particles

1.2 Harmful impacts upon measurement accuracy

2. Solution with the E-Tube

3. Competitive Advantages

4. Summary

5. Yamatake: Corporate Profile

1.1 Gas wells contain sand and rust particles

Fact: Gas wells contain sand and rust particles.

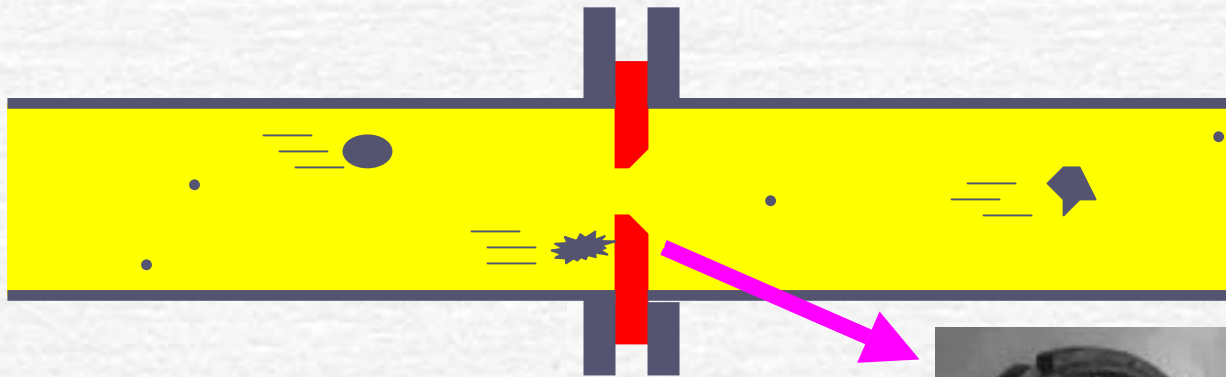

Example of Worst Cases:
The plate used only in 3 weeks

Orifice plates are easily damaged.

How are the orifice plates damaged?

Fact : There have been wells where the plate edges were worn by 0.1mm within a month.

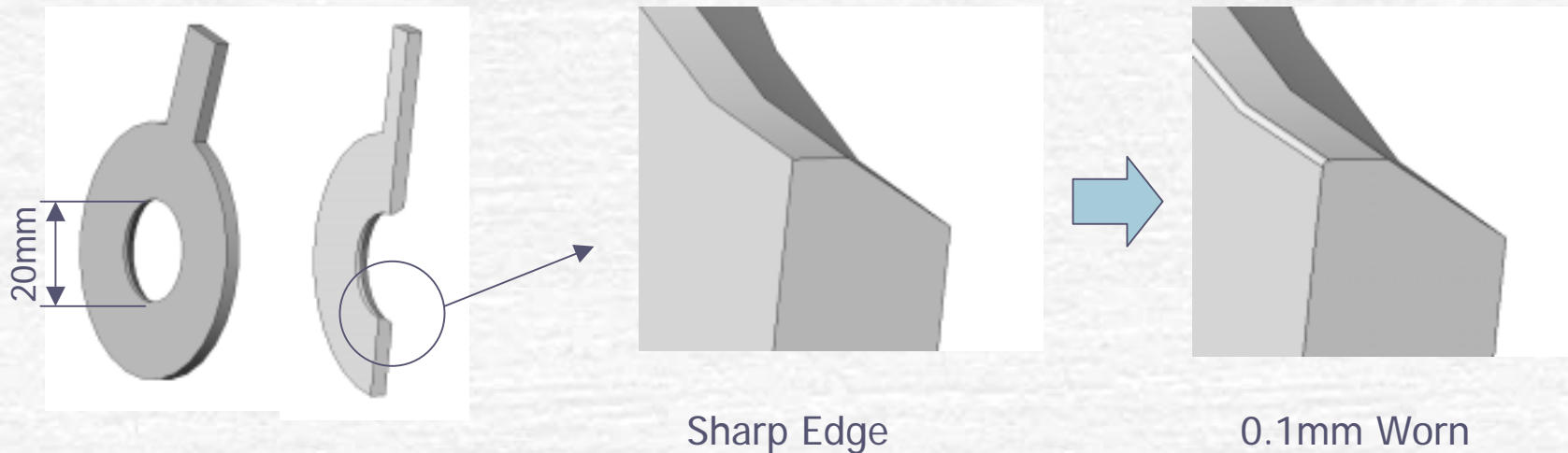

1.2 Harmful impacts upon measurement accuracy

~ Measurement inaccuracy causes profits loss

How is accuracy affected from 0.1mm?

Measurement errors from worn edges of orifice plates.

$$\text{Error} = -5.5 \times 10^2 (r/d)$$

where r : worn edge radius
d : orifice bore diameter

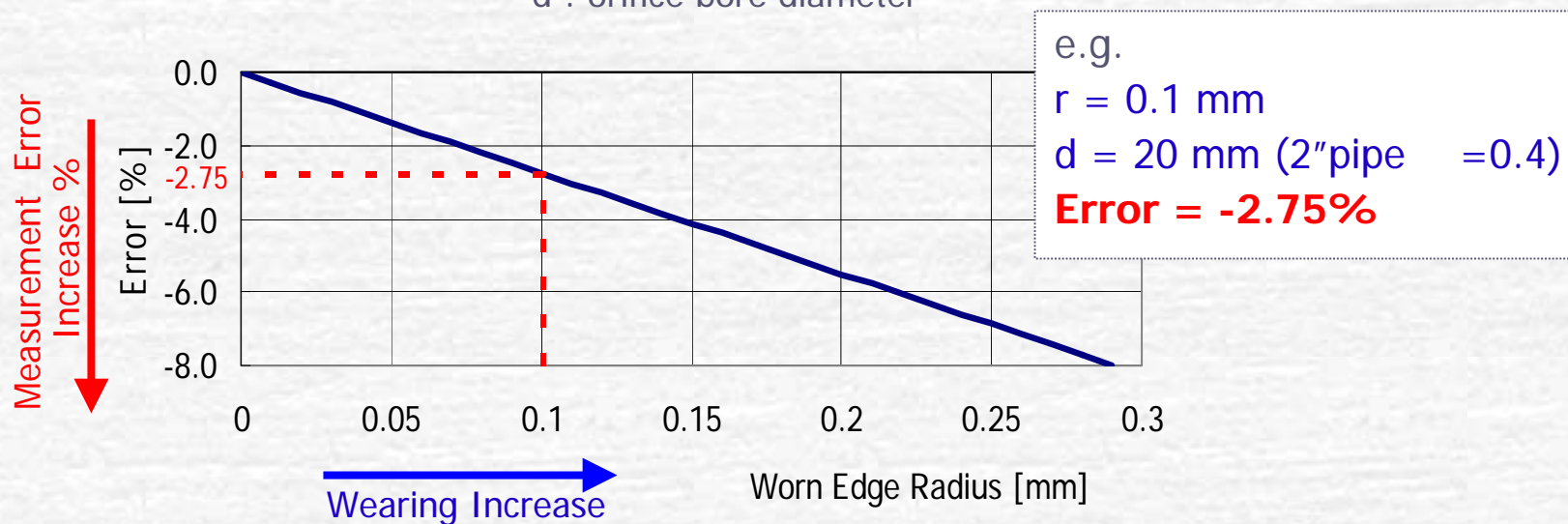

Spencer, E. A. "Study of Edge Sharpness Effects Measured During the EEC Orifice Plate Coefficient Program", International Symposium on Fluid Flow Measurement, **American Gas Association**, Washington D.C., November 16-19, 1986.

1.2 Harmful impacts upon measurement accuracy

~ Measurement inaccuracy causes profits loss

How much income is lost ?

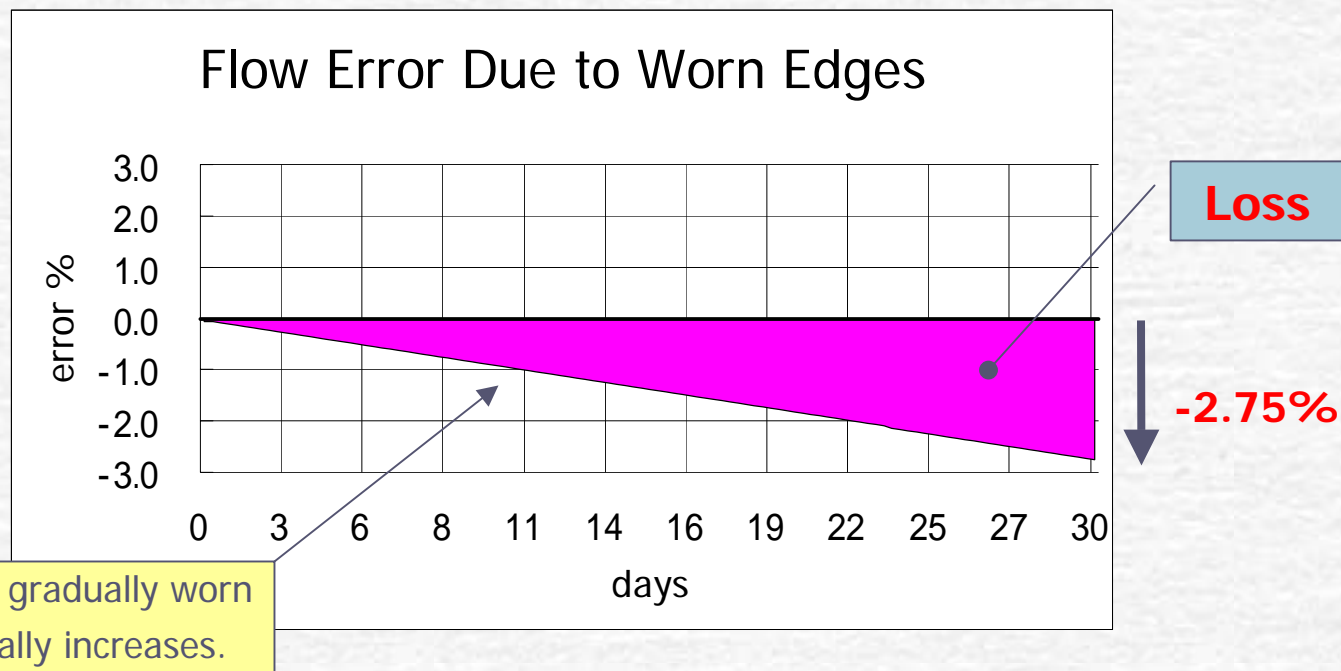

*A plate with 0.1mm worn edge after one month use,
you would have already lost **CD\$347.***

Well size: 100mcf/day
Gas price: CD\$4.2/mcf

Problem with the Orifice

Point to attack to guarantee the surest income

Gas wells contain sand and rust particles.



Sand and rust particles damage orifice plates.



Damaged plates cause underestimated measurement.

You are not receiving the full amount of income from the gas you are producing. The worn edge orifice always underestimates gas production volume.

Contents

1. Problems with the Orifice in Gas Wells
2. *Solution with the E-Tube*
 - 2.1 *Robust Design to Endure Sand and Rust*
 - 2.2 *Testing Data*
 - 2.3 *Field Experience*
3. Competitive Advantages
4. Summary
5. Yamatake: Corporate Profile

2.1 Robust Design to Endure Sand and Rust

Fact: Gas wells always contain sand and rust.

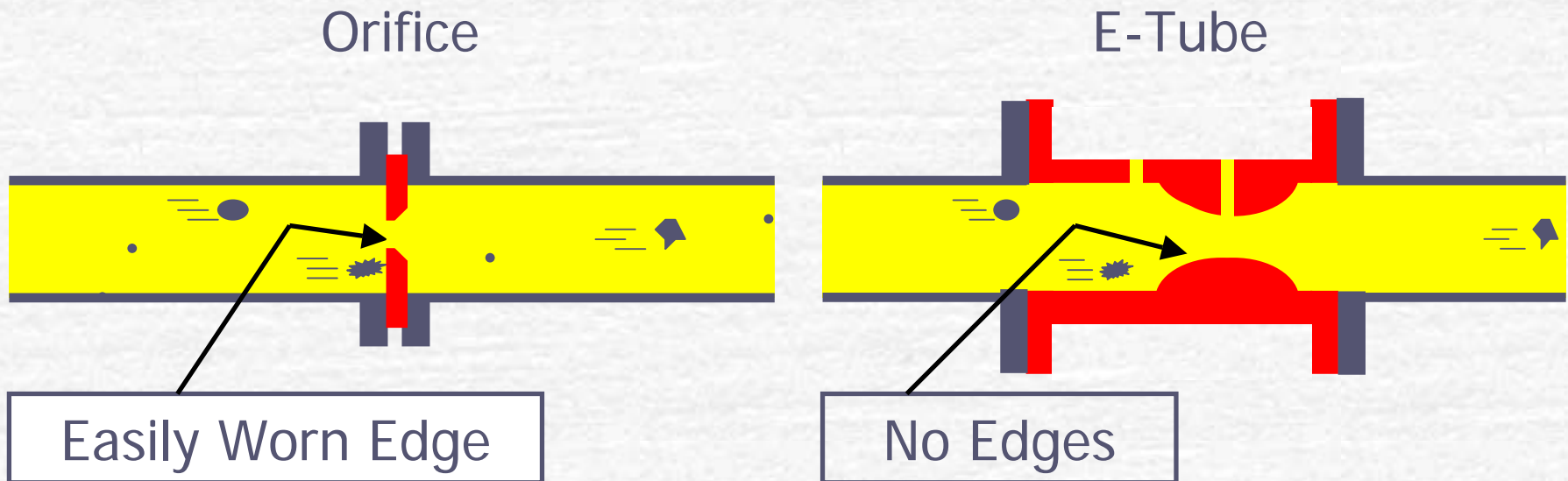

Yamatake designed the E-Tube for high durability against sand and rust where the orifice cannot endure.

2.2 Testing Data

Tests performed at NEDO Mar. '97 to Feb. '98
NEDO: New Energy Development Organization
(Japanese Government Organization)

More critical conditions than those in gas wells

Fluid : Oil with 20% Coal Particles

Numerous Scratches

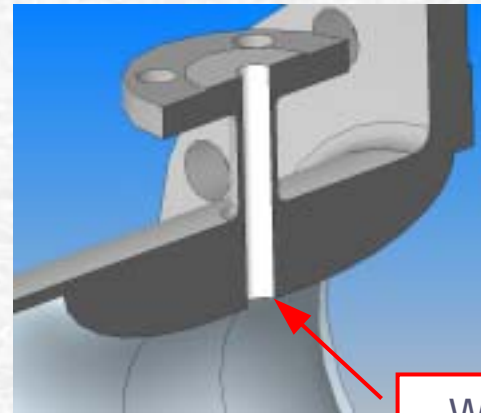
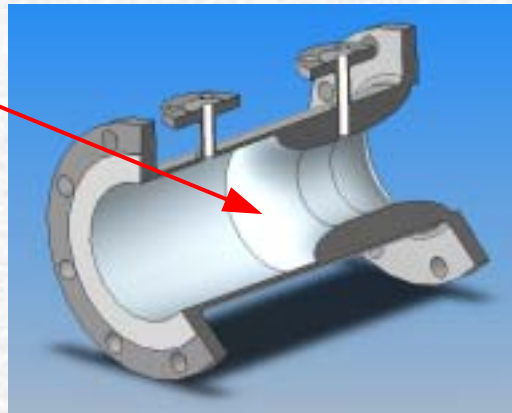

Worn Hole Inlet

Result

	Before	After
Surface Roughness	1.6 μ m	2 μ m
Hole Inlet	R 0.1mm	R 1.0mm
Flow Error	0	+0.2%

The E-Tube maintains measurement accuracy.

2.3 Field Experience

No complaints from customers in eight years and with over 700 E-Tubes out in the field.



Size	Specification				Fluid Specification				Shipment
	DP	P.rate	Mat.		fluid	Temp.	SP(kg/cm2)	ReD	
2 B	0.4	928.6	ANSI150	SUS304	Sutliene	96	3.2	85740	95/12
1 B	0.4	576		SUS304	Oxygen	10	34	77238	95/1
2 B	0.4	1245	JPI300	SUS316	Polypropowder	25	0.2	74569	96/2
4 B	0.225	349	JIS10K	SUS304	Steam	100	0	14124	96/1
2 B	0.4	488.9	JIS10K	SUS304	Water+Jusy	50	0	21259	96/3
3 B	0.6	1426	JIS10K	SUS304	Hi-Specific G.	50	0.5	127682	
2 B	0.6	4056	JIS10K	SUS304	Steam	183.3	10	877280	96/4
3 B	0.6	1593	JIS10K	SUS304	Steam	183.3	10	855105	
3 B	0.7	1584	JIS10K	SUS304	Steam	82	0.95	908549	
		2526			Metanole	127.2	1.5	818744	
6 B	0.7	1953	JIS10K	SUS316	NaOH	38	3	150941	96/5
3 B	0.7	1957	ANSI150	SUS304	R E Q	60	7	271713	
2 B	0.4	844.8	JIS10K	SUS304	AIR	20	1.2	72312	96/4
2 B	0.35	820	JIS10K	SUS304	AIR	20	1.2	48208	
4 B	0.5	1098	JIS20K	SUS304	Kaly Fluid	70	12.5	108794	96/5
6 B	0.6	939.2	JIS20K	SUS304	Kaly Fluid	116	11	370669	
1 B	0.4	prox.6000	JIS10K	SUS304	?	25	2	Approx.500	96/7
3 B	0.5	2900	JIS10K	SUS304	Hot Water	50	2	56514	96/10
6 B	0.4	1700	JIS10k	SUS316	NaOH(4%)	38	4.5	118545	96/10
1 1/2 B	0.7	2400	ANSI300	SUS304	Tori mechil amir	150	25	969000	96/10
2 B	0.25	462.1	JIS10K	SUS304	C-C GAS	20	0.4	37152	96/8
3 B	0.4	5314	JPI150	SUS316	RLGO liquid	20	13.03	27914	96/9
3 B	0.4	1525	JPI150	SUS316	LCO liquid	20	13.04	7552	
2 B	0.6		JPI150RJ	SUS304L	HC LIQUID	400	4		96/12
4 B	0.4	1700	JIS10K	SUS316	NAOH	38	4.5		96/12
2 B	0.4								96/12
2 B	0.7	3529	JIS10k	SUS304	GO2gas				96/12
1 B	0.5	1470	JIS10K	SUS316L	vinegar				96/12
2 B	0.5	800	JIS10K	SUS304	factory water	15	400KPaG		97/1
2 B	0.6	1230	JIS10K	SUS304	water	15	550KPaG		
1 B	0.35	440	JIS10K	SUS304	N2	15	700KPaG		
1 1/2 B	0.5	1000	JIS10K	SUS304	Pure water	15	400KPaG		
4 B	0.4	760	JIS10K	SUS304	Steam	158.93	500KPaG		
3 B	0.3	6000	JPI150	SUS304	Oil	38	7.9		97/1
3 B	0.3	6000	JPI150	SUS304	Oil	40	4		
1 B	0.45	1800	ANSI150	SUS304	Butadien	50	10.4		97/1
1 B	0.45	450	JIS10K	SUS316	N2	15	10KPa		97/1
1 B	0.4	850	JIS10K	SUS316L	NV30%slurry	125	4.5		97/1
1 B	0.7	2400	JIS20K	SUS304	PREliquid	-5	10		97/1
2 B	0.6	2000	JIS10K	SUS304	PRE-Gas	10	1		
2 B	0.6	6.775	JPI300	SUS304	Etylene gas	25	35	3912119	97/2
2 B	0.4	1245	JPI300	SUS316	C3+Powder	25	0.2	74569	97/2
3 B	0.4	1717	JIS10K	SUS304	Air	25	6	226948	97/3
1 B	0.4	2741	JIS10K	SUS304	H2	20	5	26388	97/3
3 B	0.4	3273	ANSI150	SUS316	EDC	70	2	87606	97/3



2. Solutions with the E-Tube

Pipes inside gas wells contain sand and rust.



Sand and Rust cause small damages to the E-Tube.



Small damages do not affect the E-Tube's measurement accuracy.

Replace for E-Tube with measurement accuracy.

Surest income: You will receive the whole amount of income from the gas you are producing.

Contents

1. Problem with the Orifice in Gas Wells
2. Solution with the Elliptical Tube
3. *Competitive Advantages*
 - 3.1 Minimum Maintenance*
 - 3.2 Less Installation Space*
 - 3.3 More Flow, Better Productivity*
 - 3.4 Longer Product Life Cycle (PLC)*
4. Summary
5. Yamatake: Corporate Profile

3.1 Minimum Maintenance

The orifice plate is easily damaged.
Plates must be changed frequently.



The E-Tube is never seriously damaged.
Always maintain measurement accuracy.

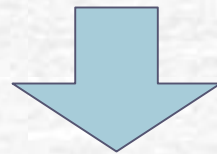

Just regular checkups are necessary according to the regulation.

3.2 Less Installation Space

Straight pipe length necessary for accurate measurement

E-Tube : $3D$ (three times the pipe diameter)

Orifice : over $10D$

The orifice needs over three times more space than the E-Tube.

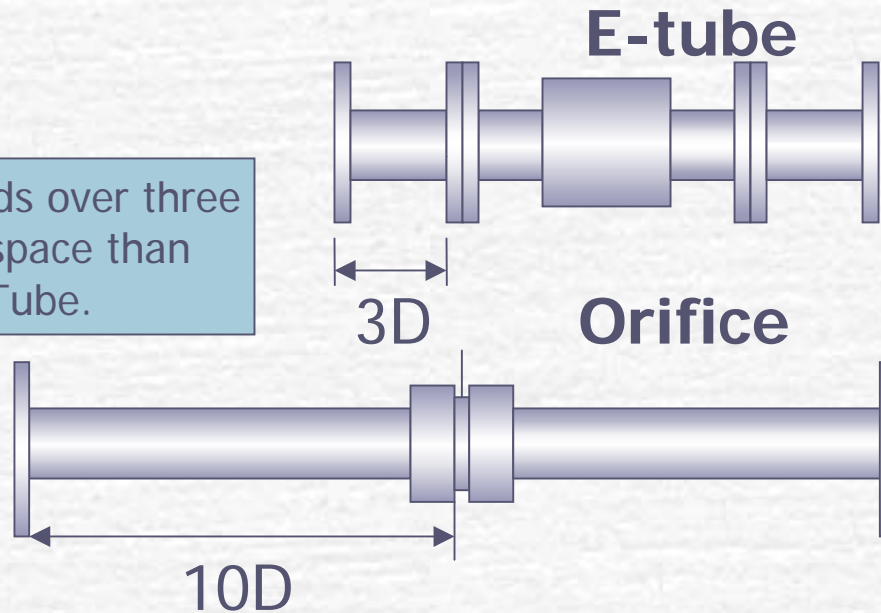

The E-Tube requires less installation space.

3.3 More Flow, Better Productivity

Less Permanent Pressure Loss

More Flow

Orifice

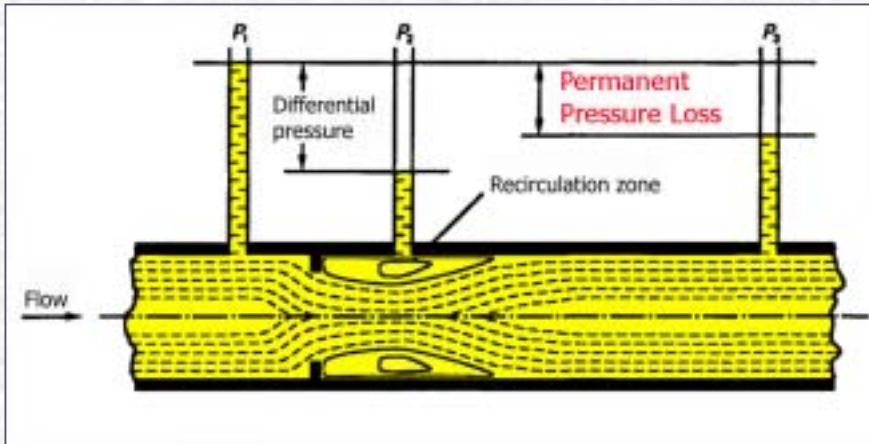

From AGA Report No.3 Part 1

E-Tube

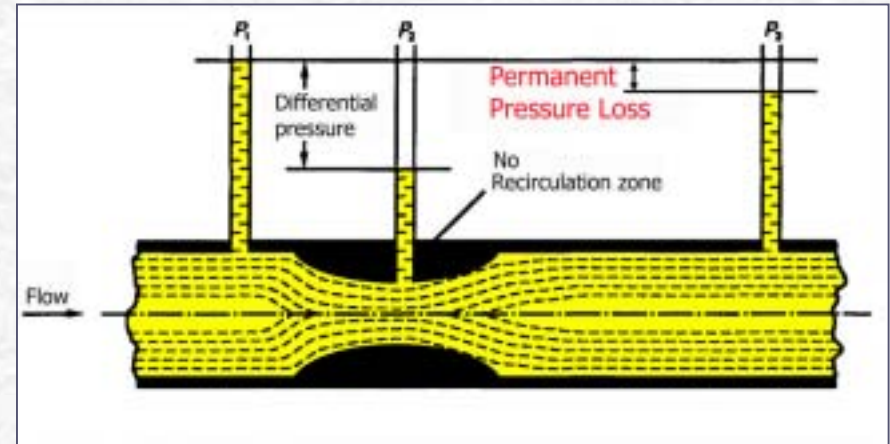

From Yamatake Test Data

40% less permanent pressure loss
40% more flow

3.4 Longer Product Life Cycle (PLC)

Gas flow decreases with time.

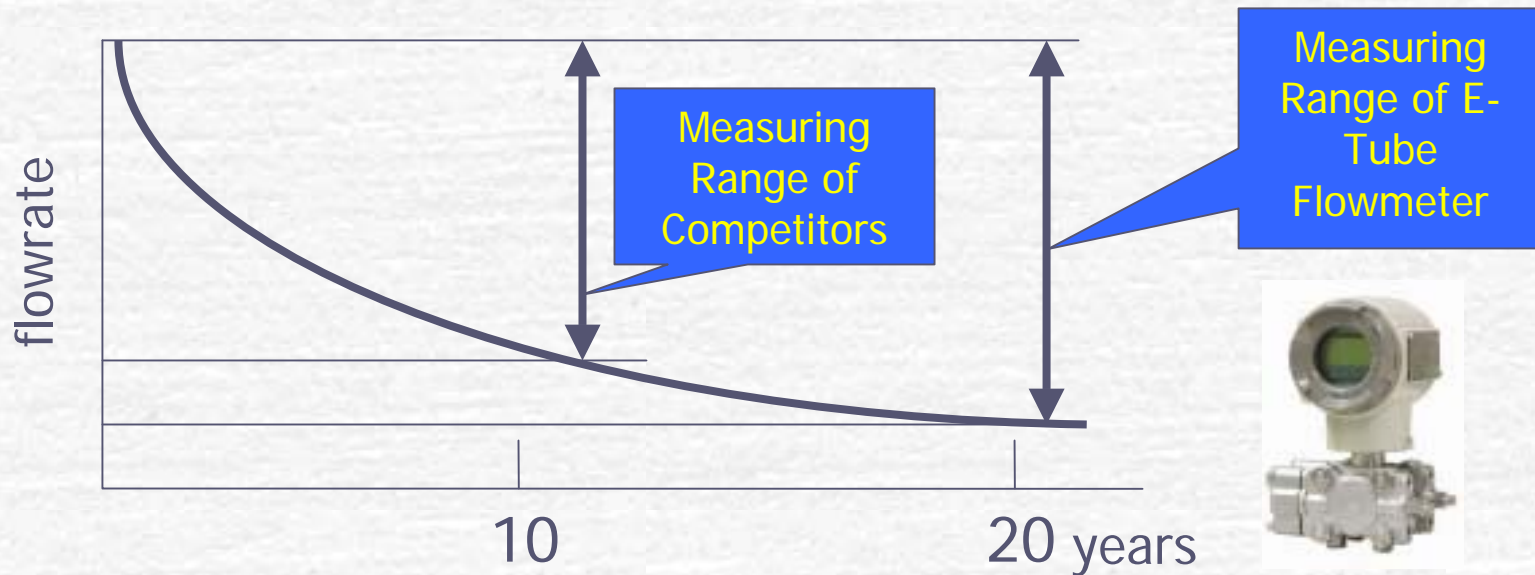

The E-Tube Flowmeter measures the flowrate for 20 years. Other Flowmeters of competitors measure the flow for 11 years on the average.

Contents

1. Problem with the Orifice in Gas Wells
2. Solution with the Elliptical Tube
3. Competitive Advantages
4. *Summary*
5. Yamatake: Corporate Profile

4. Summary

The E-Tube Flowmeter will maintain measurement accuracy in sand and rust conditions.

*Therefore, you can enjoy **the surest income.***

Furthermore, the E-Tube has the following advantages.

- No plate change. *Less maintenance.*
- Less straight pipe length. *Less installation space.*
- Less permanent pressure loss. *More flow of gas.*
- Wider measuring range. *Longer PLC.*

4. Summary

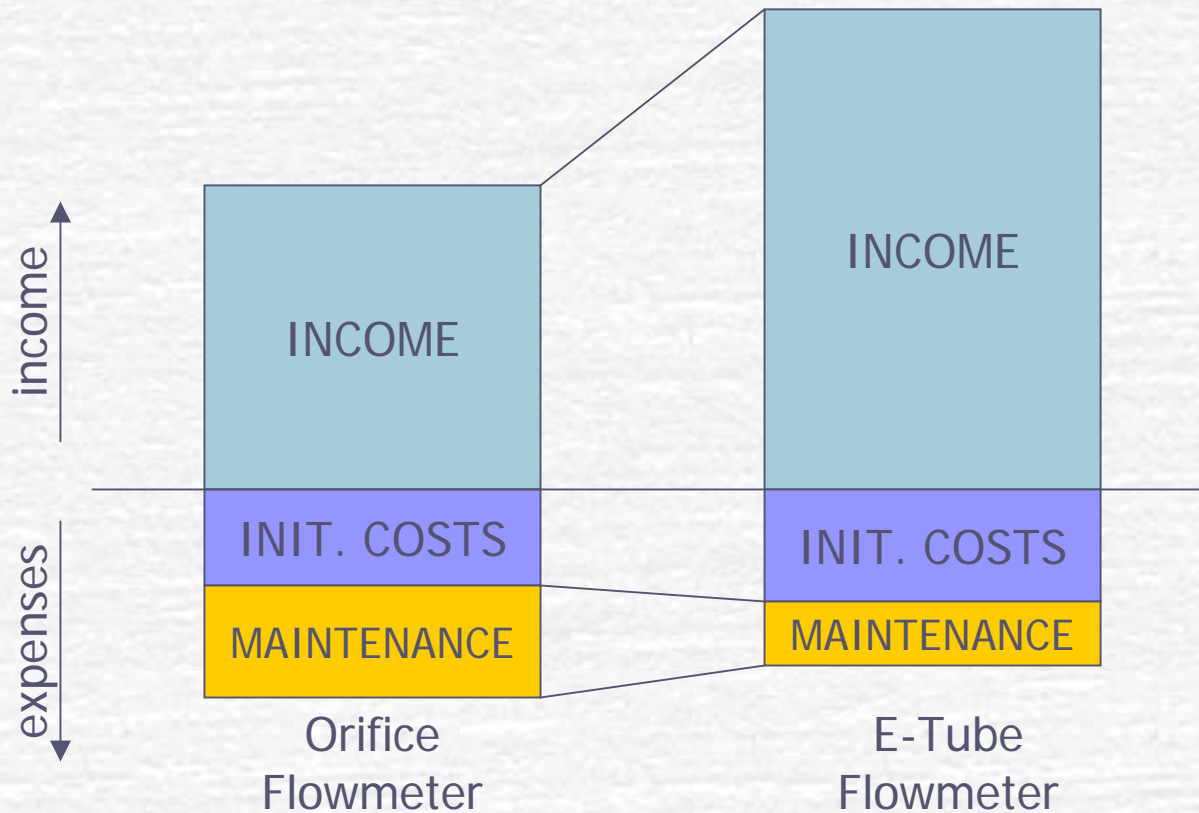

e.g. In a gas well that produces 100 mcf/day, you can enjoy more than **CD\$63,000** annually with measurement accuracy.

Question

Now, do you STILL think the orifice is the best flowmeter for your gas wells?

Contents

1. Problem with the Orifice in Gas Wells
2. Solution with the Elliptical Tube
3. Competitive Advantages
4. Summary
5. *Yamatake: Corporate Profile*

Yamatake: Corporate Profile

- Founded in 1906.
- Corporate creed
 “**Savemation**” – Saving by Automation
- Manufacturer of various control instruments, including control valves, flowmeters, and pressure transmitters.
- Ranked as No.2 position Multivariable Transmitter Manufacturer in the world.

Customers

SONY

Nippon Steel Corporation

HONDA

 **TOYO ENGINEERING CORPORATION (TEC)**

 **TOYOTA**

HITACHI
Inspire the Next

 **出光**

Shell
昭和シェル石油株式会社

ENEOS

新日本石油
Your Choice of Energy

Shin-Etsu
Shin-Etsu Chemical Co.,

**MITSUBISHI
CHEMICAL**

JGC

Canon

 エネルギー・フロンティア
TOKYO GAS

Enjoy!
Coca-Cola

SUMITOMO CHEMICAL