

SP. No.

Yamatake Corporation

製品仕様書
SPECIFICATIONS

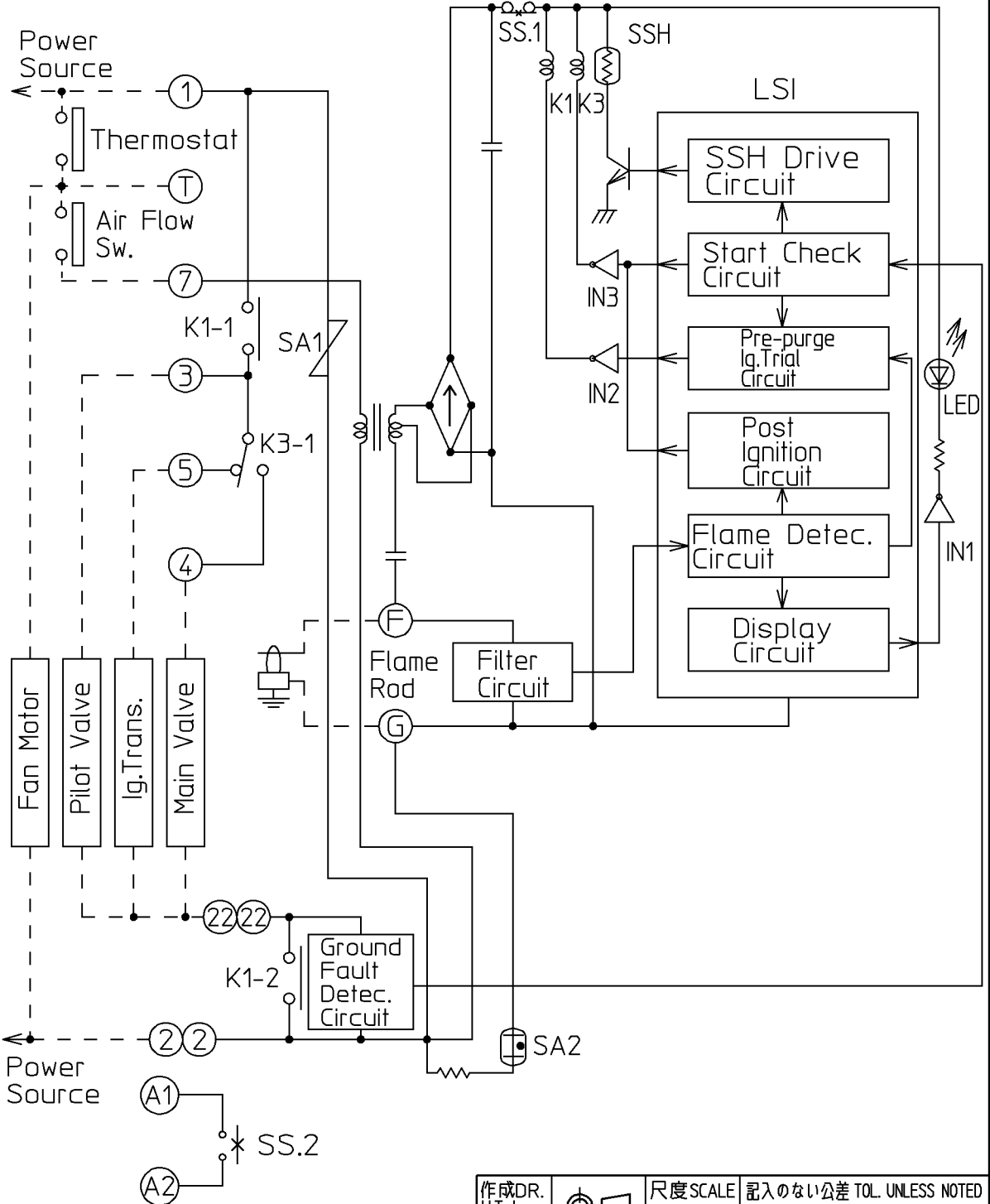

作成DR. H.Tabuse 2.1.'84	形番 MODEL	尺度SCALE 1/10	記入のない公差 TOL. UNLESS NOTED ±0.1
検図CHK. Y.Yamamoto 2.2.'84	名称 NAME	R4750B108-2,208-2 R4750B130-1,230-1	FSG50-LSI PROTECTORELAY
認可APPD. S.Shiragaki 2.2.'84	日付DATE	2.21.'98	改番REV. 03
頁 PAGE	改番 REV.	改番 REV.	4/5

03	JEO98-1114	12.18.'98	M.Takamura	S.Miura
1	Changed Model No.	4.23.'86	Y.S	M.O
改番 REV.	来歴 RECORD	日付 DATE	担当 BY	検閲 APPD.

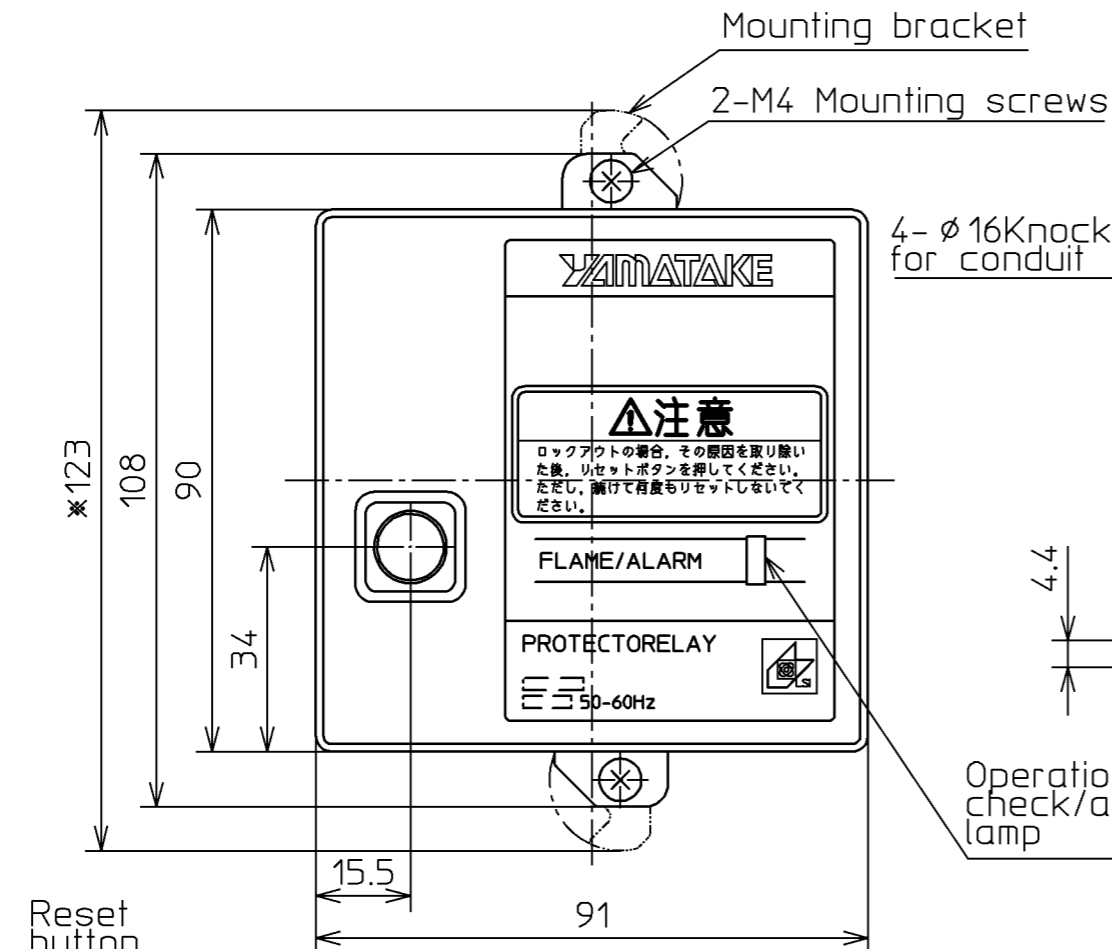

SUB-BASE MOUNTING DIMENSIONS

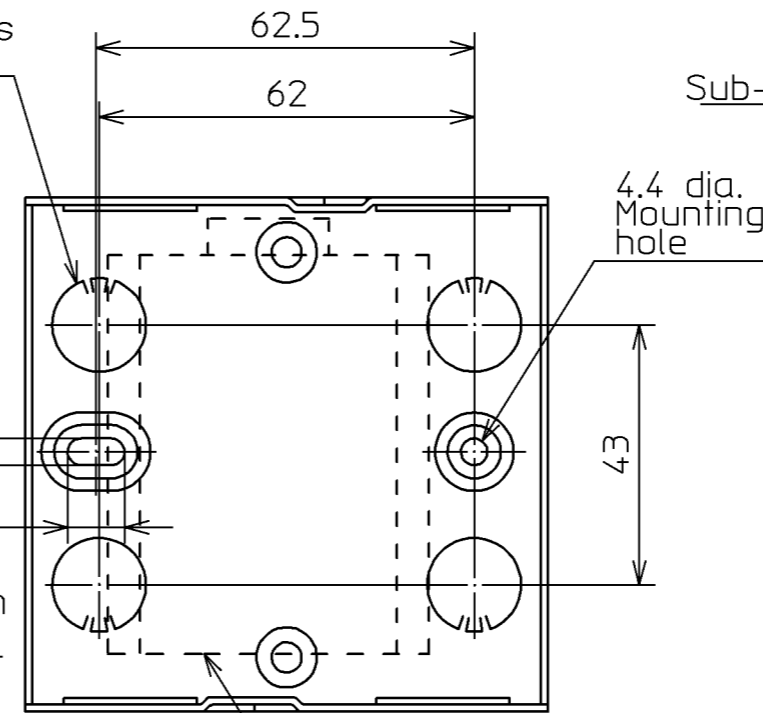

A TERMINAL ARRANGEMENT

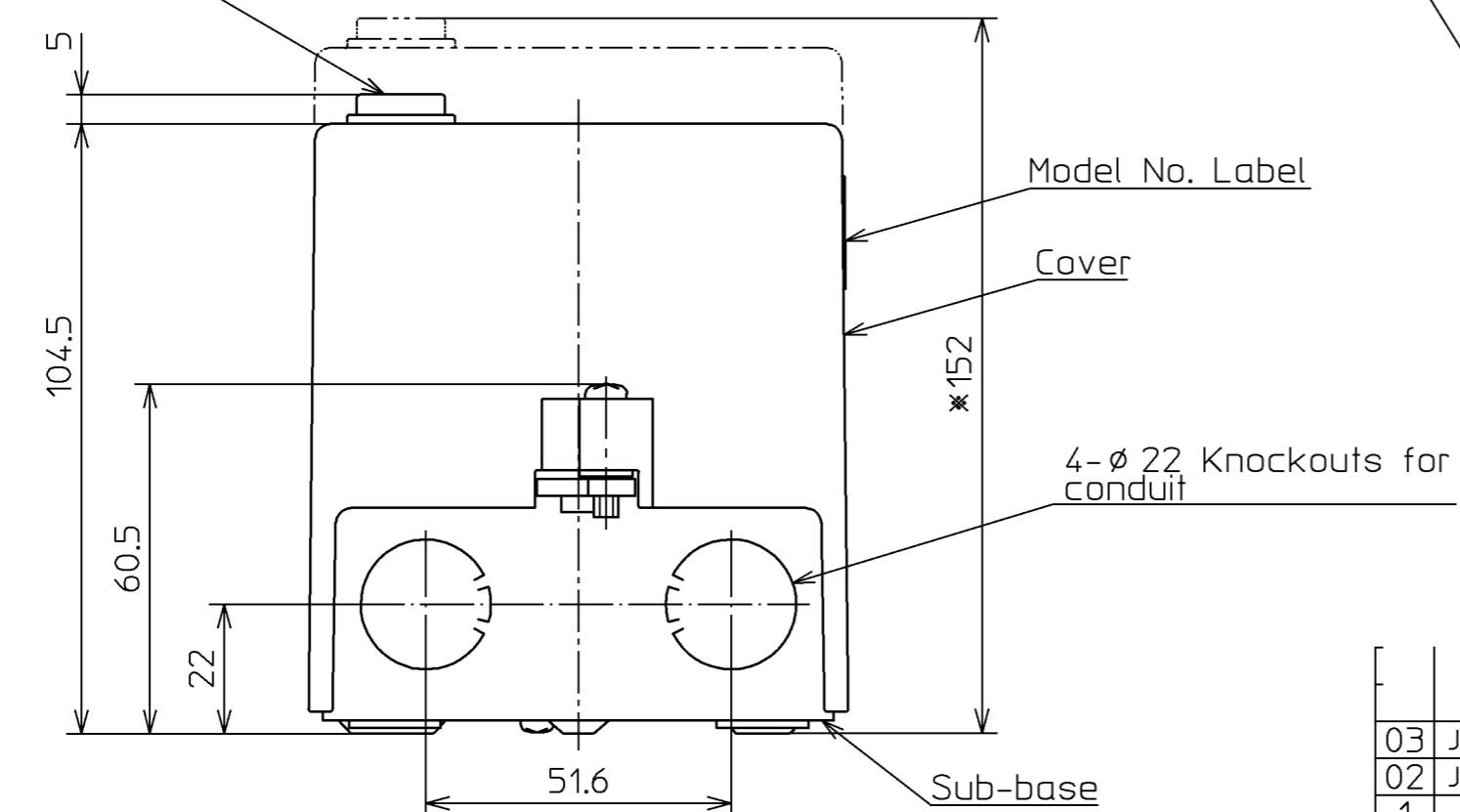
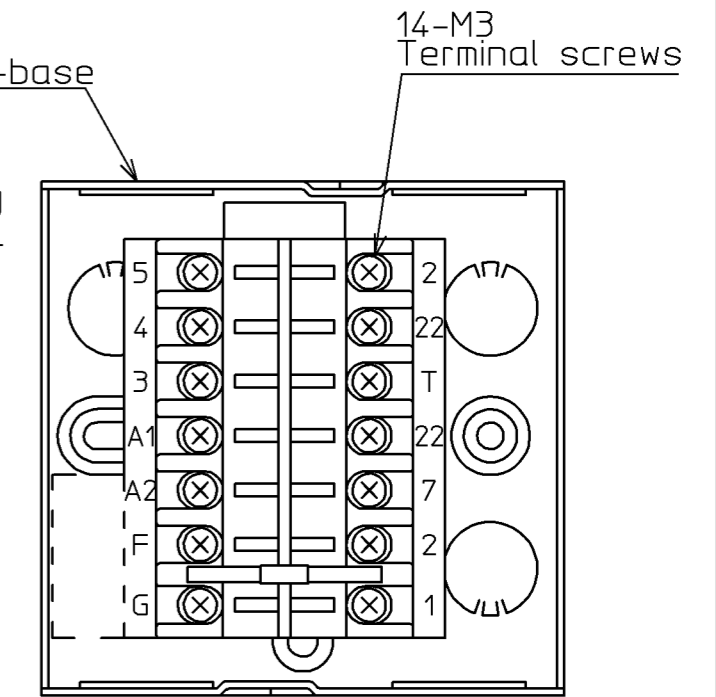

For terminal arrangement, refer to A for wiring, refer to sheet 4/5

WIRING MEANS

M3 Terminal screw

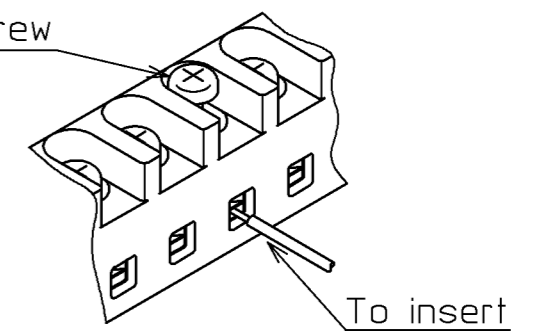

*. Note: Dimension for mounting or removing the device

03	JE098-1114	12.21.'98	M.Takamura	S.Miura
02	JE095-0622	10.5.'95	I.W	Y.N
1	Redrawn	6.17.'86	Y.S	M.O
改番 REV.	来歴 RECORD	: 日付 DATE	担当 BY	検閲 APPD.

作成DR. Y.Sugaya 6.17.'86	検図CHK. M.Ogido 6.19.'86	認可APPD. K.Murata 6.23.'86	日付DATE 12.21.'98	尺度SCALE CD	記入のない公差 TOL. UNLESS NOTED
形番 MODEL	R4750B108-2,208-2 R4750B130-1,230-1		名称 NAME	FSG50-LSI PROTECTORELAY	
図番 NO.	AD10107E		改番REV.	03 / 5	

SP.NO.

Yamatake Corporation

製品仕様書
SPECIFICATIONS

“RESTRICTIONS ON USE”

This product has been designed, developed and manufactured for general-purpose application in machinery and equipment.

Accordingly, when used in applications outlined below, special care should be taken to implement a fail-safe and/or redundant design concept as well as a periodic maintenance program.

- Safety devices for plant worker protection
- Start/stop control devices for transportation and material handling machines
- Aeronautical/aerospace machines
- Control devices for nuclear reactors

Never use this product in applications where human safety may be put at risk.

1	00	00	First issue	12-2-02	Harada	Miura
頁	改番	改番	来歴	日付	担当	検閲
	REV.	REV.	RECORD	DATE	BY	APPD.