

# Max Safety Multi Protectoglo (with UV Tube Diagnostic Circuit) R4332B

## User's Manual

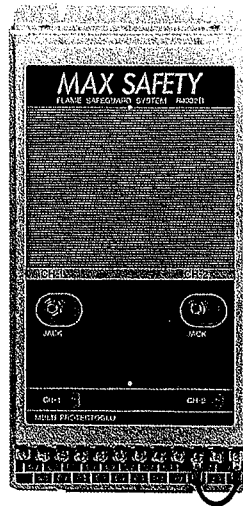

## RESTRICTIONS ON USE

This product has been designed, developed and manufactured for general-purpose application in machinery and equipment.

Accordingly, when used in applications outlined below, special care should be taken to implement a fail-safe and/or redundant design concept as well as a periodic maintenance program.

- Safety devices for plant worker protection
- Start/stop control devices for transportation and material handling machines
- Aeronautical/aerospace machines
- Control devices for nuclear reactors

Never use this product in applications where human safety may be put at risk.

### Caution:

These flame safeguard multiburner modules are crucial to the safe operation of combustion devices. Consult this manual before attempting to operate the equipment.

Do not attempt to perform installation, connections, maintenance, checks, adjustments or any other work on this equipment without the help of engineers who are familiar with combustion and combustion safety device technology.

## TABLE OF CONTENTS

1. INTRODUCTION .....	1
2. DIMENSIONS .....	1
3. INSTALLATION AND WIRING .....	2
4. OPERATION .....	6
5. CHECKOUT AND ADJUSTMENT .....	8
6. MAINTENANCE .....	10
7. SPECIFICATIONS .....	11

# 1.

# INTRODUCTION

The R4332B flame safeguard multiburner module is a highly reliable 2-channel type flame safeguard control with Dynamic Self-Check circuit and flame detector diagnostic function. This device can be used for batch or continuous operation of various combustion equipment. The device can monitor multiburners individually, and immediately shut off the main fuel valve after flame response at occurrence of flame failure or operation error during combustion.

The R4332B is used with a ultraviolet flame detector having Dynamic Self-Check function and dedicated amplifiers.

## Features

- The Dynamic Self-Check function is used to continuously self-check the flame detector and flame detection circuit of amplifier to ensure fail-safe.
- If an error has occurred in a flame detector or amplifier circuit before operation start, the main fuel valve does not open to secure the safety combustion even if start-up operation is performed.
- If trouble has occurred in a flame detector or amplifier circuit during combustion, the main fuel valve and pilot valve are also shut off.
- The flame detector diagnostic function is used to diagnose the UV tube of flame detector during combustion. When an error is detected, the UV alarm lamp lights.
- The dedicated amplifiers of various flame detectors and relays are plug-in type and can be easily mounted or dismounted.
- A flame current measuring jack is provided on amplifier. The flame current can be easily measured using the W136A test meter (sales discontinued now) or an equivalent tester.
- The terminals (FS1 and FS2) for flame current measurement are provided as standard for continuous monitoring of flame current (voltage conversion 0 to 50mV).

# 2.

# DIMENSIONS

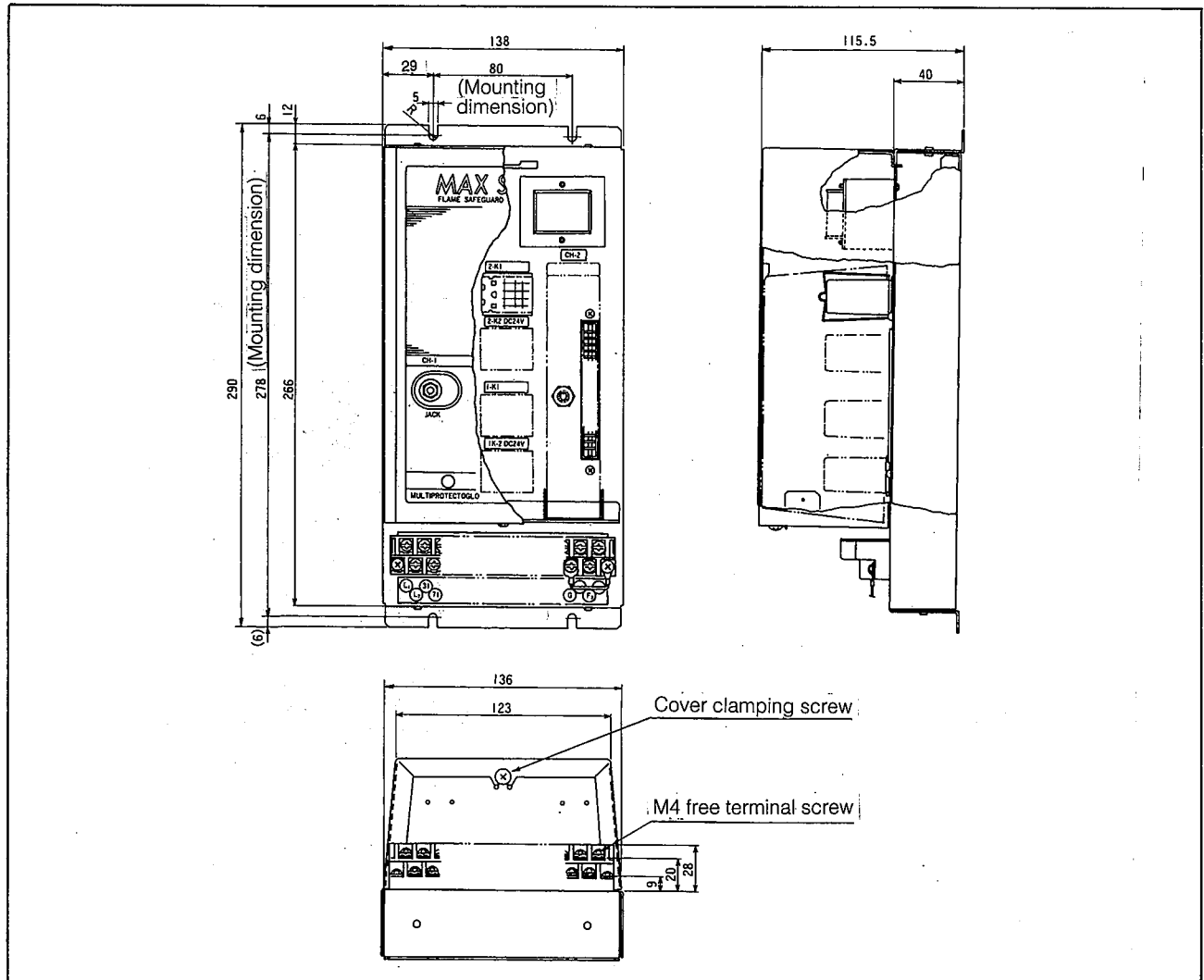

Fig. 1 R4332B (2cH)

# 3.

# INSTALLATION AND WIRING

## Cautions:

- (1) Never mount the equipment where it might be exposed to the following:
  - Chemicals or corrosive gases (ammonia, sulfur, chlorine, ethylene compounds, acids)
  - Water drops or excessive humidity
  - High temperatures
  - Continuous vibrations
- (2) Never attempt to perform installation and wiring without referring to this instruction manual or an authorized substitute supplied by the manufacturer.
- (3) Perform all wiring according to specified standards.
- (4) In order to prevent shocks or other accidents, connect the power supply last.
- (5) Suppress the terminal loads below the rated values.
- (6) Make sure the power and voltage match those specified on the equipment.
- (7) Select reliable timers, auxiliary relays and other parts if optional equipment is necessary.
- (8) Be sure to ground the casing of the burner to an Earth of less than 100Ω.
- (9) Don't run the power, high voltage (HV), and flame detector lines together or through the same conduit. Connect and leave at least 10 cm between the HV line and the R4332B.
- (10) Make sure the HV line has been securely connected. If not, high-frequency electric waves may lead to erroneous operations. Mount the ignition transformer directly onto the burner unit or a part grounded to it.
- (11) Check that all wiring has been connected correctly. If not, operational failures may occur.

## 1. Mounting Position

Mount the instrument so that the terminal board faces downward as shown in Fig. 1.

## 2. Installation

- (1) Mount the instrument by tightening the four mounting screws as shown in Fig. 1.
- (2) After loosening the cover screws, detach the cover and mount the amplifier as shown in Fig. 2.
- (3) Insert the PC board into the connector securely with the amplifier nameplate facing outward as shown in Fig. 2.
- (4) Remount the instrument cover.

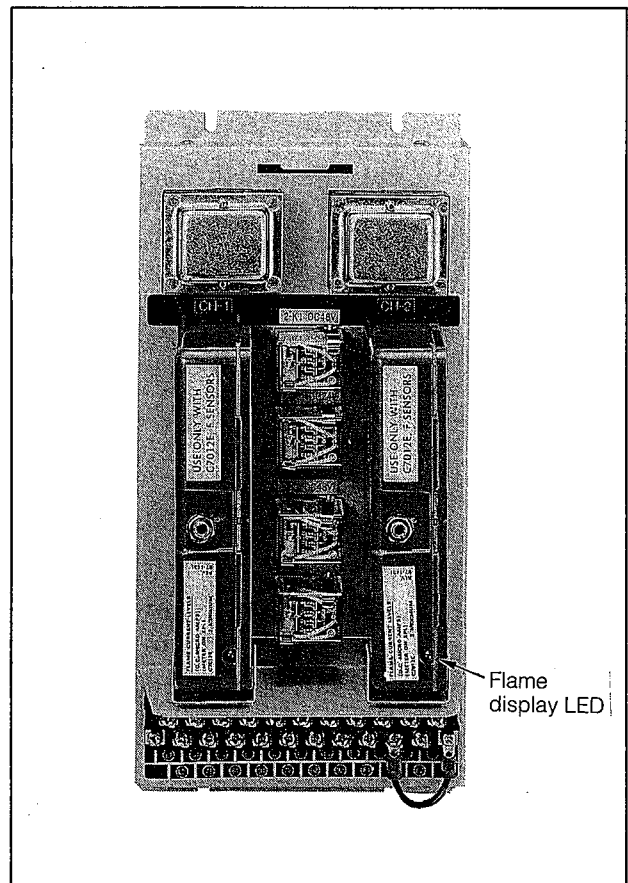

Fig. 2. Installation of Amplifier

### 3. Wiring Method

- Perform wiring for the 2-burner R4332B according to Fig. 4.
- If the voltage (H) and grounding lines (G) are separately identified, connect (H) to terminal (L<sub>1</sub>), and (G) to terminal (L<sub>2</sub>), and connect the valve and load to (G) as illustrated in Fig. 3 and 4.
- To wire various flame detectors, use terminals (F) and (G) for the C7012E, F and terminal (F) and (FS) for the C7076A, D. See Fig. 5.
- For continuous flame current measurement, connect a voltmeter or a recorder with an input impedance of higher than 100 kΩ in the following manner: Connect the C7012E, F to terminals (G) and (FS) (+ to (G) and - to (FS)). Connect the C7076A, D to terminals (G) and (FS) (+ to G and - to FS). Connect terminal (F) and (G) via a resistor. See Fig. 5.
- Use an overload preventer as required.
- Don't disconnect the jumper wire from terminal (G<sub>1</sub>) or (G<sub>2</sub>), except when conducting the dielectric strength test.
- Terminal NC at the center of the board should not be used.
- Wiring diagram (Fig. 4) shows an individual manual ignition system. The stop switch is used to stop all channels.
- It is recommended that JAN standard coaxial cables RG-11/U or equivalent be used as flame detection signal cables between the C7012E, F flame detector and the R4332B.

The signal lines between the flame detector and R4332B are desired to be as short as possible, because the flame currents may be reduced due to the stray capacity between these lines.

Table 1 shows the allowable lengths of these cables.

#### (1) Wrong wiring

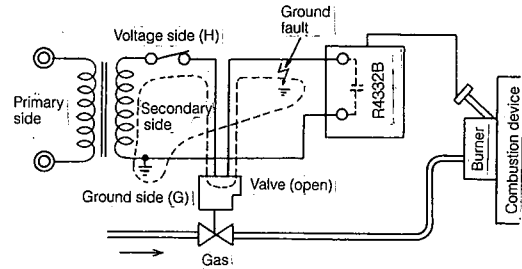

Assume that wrong wiring is conducted as shown in the connection diagram above. If insulation breakdown should occur in the connection between the R4332B and valve, and a ground fault takes place, the ground fault current flows through the valve, and the valve opens. Thus, there is a danger that the gas flows out and it causes explosion.

#### (2) Correct wiring

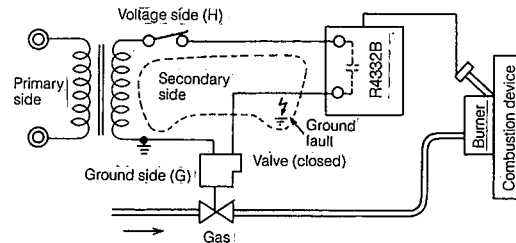

When the proper wiring is conducted as shown in the connection diagram above, no ground fault current flows through the valve even if a ground fault occurs due to insulation breakdown on the voltage side (H). Therefore, the valve won't open, and the danger of gas flow-out is eliminated.

Fig. 3 Wiring of Power Supply and Valve

Table 1

	Allowable length
C7012E, F	JAN RG-11/U approx. 50 m
C7076A, D	IV cable (2 mm <sup>2</sup> ) 600 V ac, vinyl-insulated wire approx. 300 m



**Caution:**

- (1) Read the C7012E, F and the C7076A, D instructions carefully when connecting equipment to the flame detector.
  - (2) Use a flame ammeter with an input impedance higher than 100 kΩ and connect it with a separate relay terminal.
  - (3) Never connect the flame ammeter to terminals F<sub>1</sub> or F<sub>2</sub>, or erroneous operations will result.
  - (4) Make sure that the shutter voltages (100 V or 120 V) are equal when the R4332B is used with a UV flame detector (7012E/F, C7076A/D).
- Be careful when selecting the supply voltage of UV flame detector since 100 V and 208 V models are available.

Model	Operating voltage	Shutter voltage	Flame detector							
			C7012E1211		C7012E1245		C7012E1146		C7012F1060	
			Operating voltage	Shutter voltage	Operating voltage	Shutter voltage	Operating voltage	Shutter voltage	Operating voltage	Shutter voltage
R4332B 100-1	100 Vac	100 Vac	100 Vac	100 Vac	-	-	-	-	-	-
R4332B 104-1	100 Vac	120 Vac	-	-	120 Vac Note 1	120 Vac	-	-	120 Vac Note 1	120 Vac
R4332B 200-1	200 Vac	120 Vac	-	-	-	-	208 Vac	120 Vac	-	-

Model	Operating voltage	Shutter voltage	Flame detector							
			C7076A105		C7076A1023		C7076D1001-1		C7076D1019-1	
			Operating voltage	Shutter voltage	Operating voltage	Shutter voltage	Operating voltage	Shutter voltage	Operating voltage	Shutter voltage
R4332B 100-1	100 Vac	100 Vac	100 Vac	100 Vac	-	-	100 Vac	100 Vac	-	-
R4332B 104-1	100 Vac	120 Vac	-	-	-	-	-	-	-	-
R4332B 200-1	200 Vac	120 Vac	-	-	200 Vac	120 Vac	-	-	200 Vac	120 Vac

Note 1 Since the power voltage of UV flame detector is different from the R4332B's, wire it separately.

**C7012E, F**

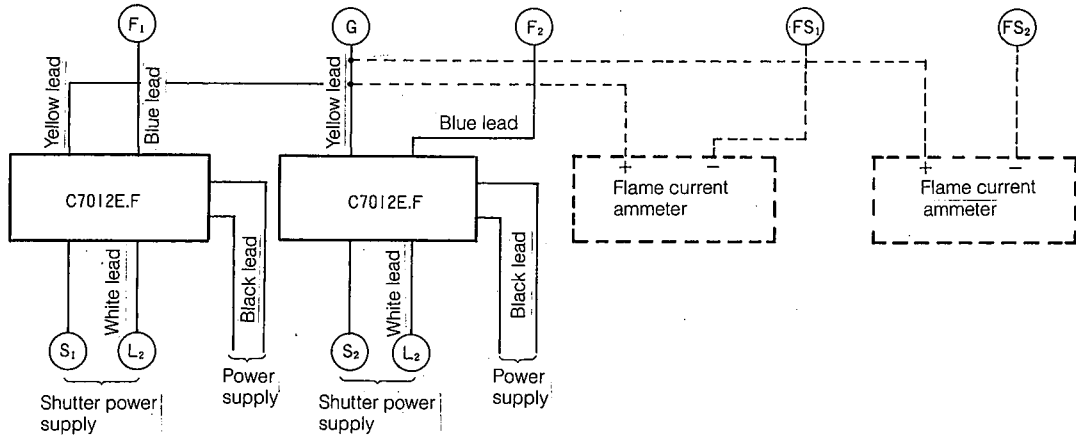

**C7076A, D**

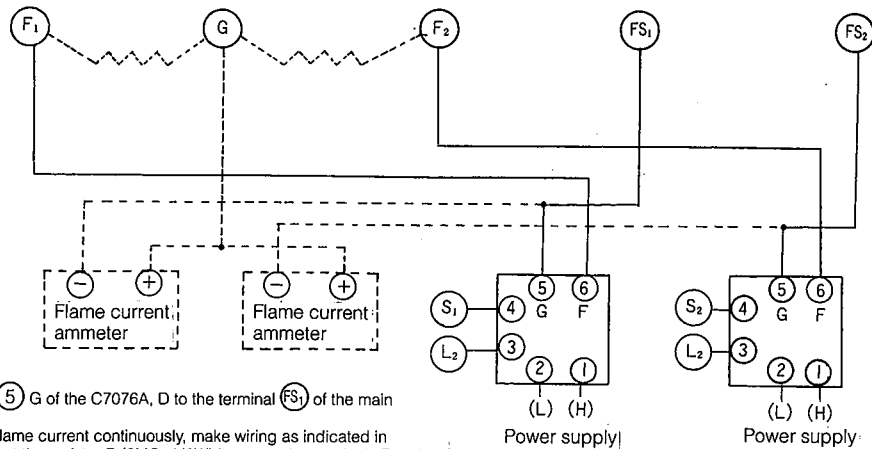

- Note 1: Connect the terminal (5) G of the C7076A, D to the terminal (FS<sub>1</sub>) of the main unit.  
 2: When measuring the flame current continuously, make wiring as indicated in dotted line, and connect the resistor R (3MΩ, 1/2W) between the terminals F and G.

**Fig. 5 Wiring Diagrams of Various Flame Detectors**

**Caution:**

If the POWER or STOP switch is turned on and off intermittently, erroneous operations may occur. Maintain an interval of about 10 seconds between on and off actions.

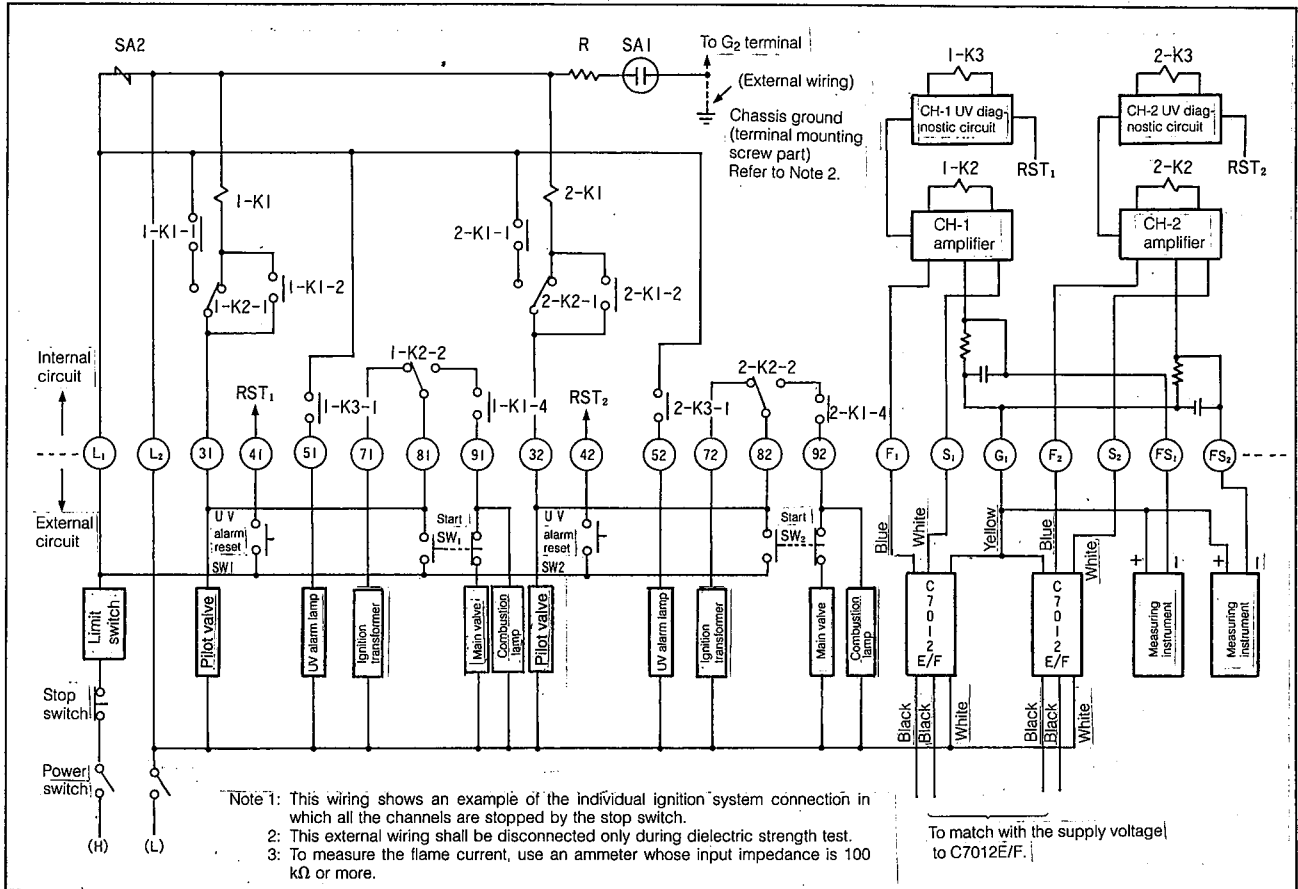

**Fig. 6 Wiring the R4332B to External Devices (Individual manual ignition)**

**1. Normal functions (See Fig. 6)**

Operation	R4332B functions	Unit conditions
Turn on POWER switch. Turn on limit switch.	A voltage is applied to (L <sub>1</sub> ) and (L <sub>2</sub> ). (A voltage is applied to the amplifier.)	—
Continue pushing the START switch SW1 until the combustion lamp is confirmed. (Terminals (41), (51).)	<ul style="list-style-type: none"> <li>When power is applied to terminal (31), flame relay contact 1-K2-1 is closed (false fire check), and load relay 1-K1 is excited through the flame relay contact.</li> <li>When the pilot flame is detected, flame relay 1-K2 is excited. Contacts 1-K1-1 and 1-K1-2 are turned on to hold the 1-K1 relay.</li> <li>1-K2-2 and 1-K1-4 turn on.</li> </ul>	Ignition transformer starts operating. Pilot valve opens.
Release START switch SW1.	—	Ignition transformer stops. Main valve opens to ignite main burner. Normal operation is started.
Push STOP switch. (Stop operation)	<ul style="list-style-type: none"> <li>All relays are de-energized.</li> </ul>	Pilot valve and main valve are closed.
Flame extinguished during operation	<ul style="list-style-type: none"> <li>All relays are de-energized in the channel where the flame was extinguished.</li> </ul>	Pilot valve and main valve are closed.
When UV diagnostic circuit detects an error.	<ul style="list-style-type: none"> <li>2K relay is turned OFF and all relays in that channel are non-excited due to flame extinction. When flame is detected at shutter close time, UV diagnostic circuit is energized.</li> <li>After the cause of UV alarm is located, UV alarm lamp can be reset by pressing UV alarm reset switch (refer to page 11).</li> </ul>	UV alarm lamp lights up.

## 2. Dynamic self-check operation

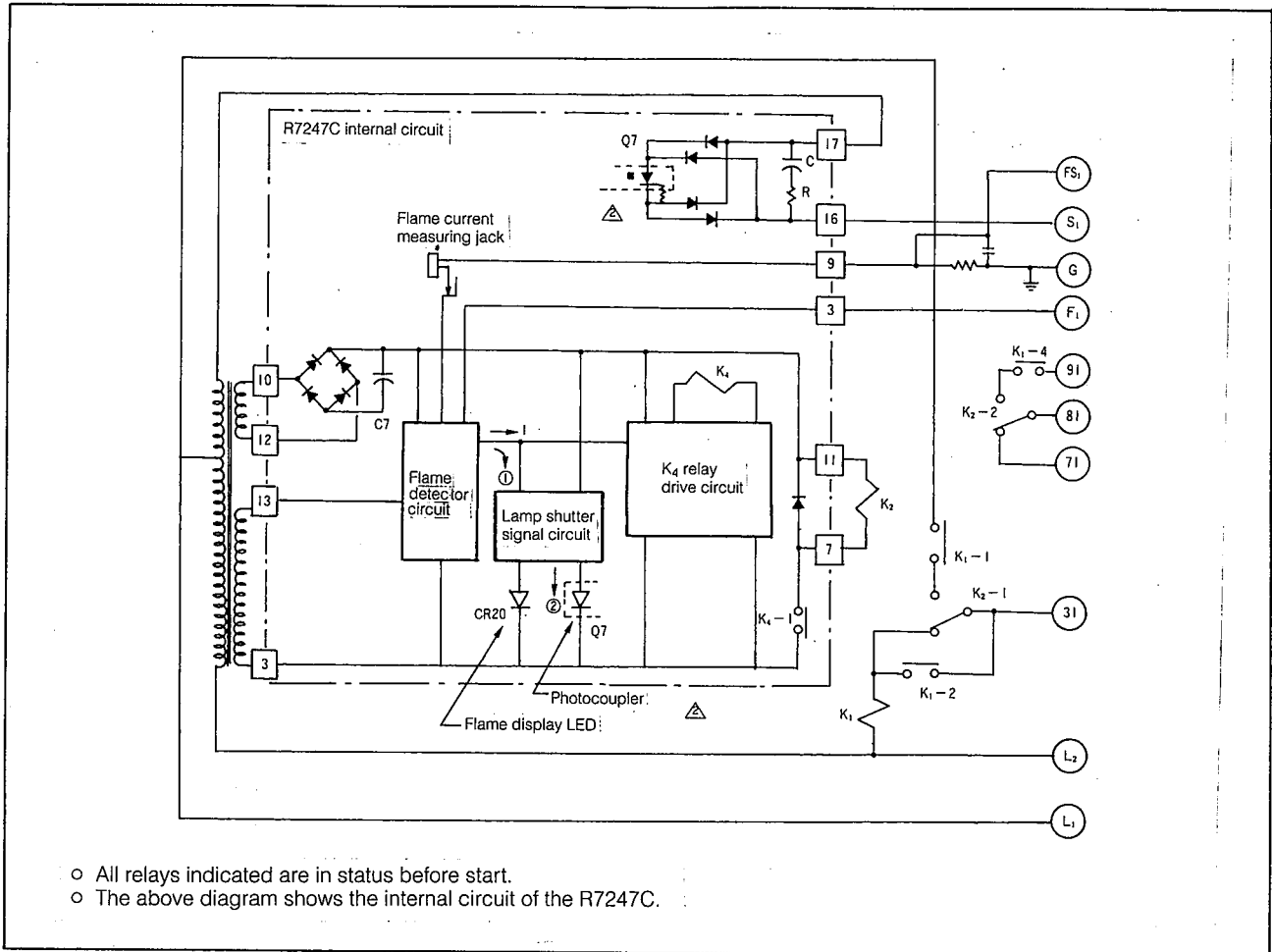

Fig. 7 Internal Circuit Diagram of the R4332B+R7247C

### Normal functions

- (1) A voltage is applied to terminal (L<sub>1</sub>) and (L<sub>2</sub>). (This voltage is applied from the transformer to the amplifier.)
- (2) The lamp shutter signal circuit is operated by a no flame signal ① on the flame detection circuit, and photocoupler Q7 is turned on by signal ②.
- (3) When photocoupler Q7 turns on, a voltage is generated at terminals (S<sub>1</sub>) and (L<sub>2</sub>), causing the flame detector shutter to be open.
- (4) When a voltage is applied to terminal (31), load relay K<sub>1</sub> is energized through flame relay contact K<sub>2</sub>-1 (closed: false flame check).
- (5) When the flame detector detects a flame, the flame display LED flickers due to the on-off operation of the lamp shutter signal circuit. Photocoupler Q7 turns on and off to start opening and closing the shutter at the same time.
- (6) The K<sub>4</sub> drive circuit functions to energize K<sub>4</sub>, causing K<sub>4</sub>-1 to turn on to energize K<sub>2</sub>. Load relay K<sub>1</sub> is held by flame relay contact K<sub>2</sub>-1.
- (7) When the flame goes out, photocoupler Q7 turns on, the shutter remains open, the K<sub>4</sub> drive circuit does not function, and the relay is de-energized. The flame display LED goes out.

### Abnormal functions

- (1) Flame detection sensor trouble
  - If an existing flame is not detected, the K<sub>4</sub> relay is de-energized, and the flame display LED does not light.
  - If a flame is detected even when one does not exist, the flame signal does not turn on and off but remains on, because the flame signal is turned on after closing the shutter. Accordingly, the K<sub>4</sub> drive circuit does not function, and the K<sub>4</sub> relay is de-energized. The flame display LED remains lit.
- (2) Lamp shutter signal circuit trouble  
 Photocoupler Q7 remains on or off, and the shutter remains on or off.  
 As a result, the K<sub>4</sub> relay is de-energized.

		Flame display LED	UV alarm lamp
Shutter open	A flame exists	ON	OFF
	No flame exists	OFF	OFF
Shutter closed	A flame exists	OFF	ON
	No flame exists	OFF	OFF

- (3) K<sub>4</sub> relay drive circuit trouble  
 When the drive circuit in this circuit turns on and off, the K<sub>4</sub> relay is energized. If this drive circuit does not function, the K<sub>4</sub> relay is de-energized.  
 A flame exists. .... Flame display LED flickers.  
 No flame exists. .... Flame display LED does not light.

# 5. CHECKOUT AND ADJUSTMENT

## Caution:

Pay careful attention when performing these tests, since voltage is applied to most of the terminals.

### Preliminary check

- (1) Check all connection points.
- (2) Make sure equipment is installed where the ambient temperature is within the allowable range and the power supply voltage is within the rated value.
- (3) Make sure the flame detector is mounted correctly. (Refer to the corresponding instruction manual.)
- (4) Make sure the burner has been adjusted correctly.
- (5) Check the exhaust mechanism of the stack.
- (6) Make sure the flame amplifier and flame detector are correctly combined with each other.

### Checkout procedure

Perform the following checks completely to guarantee safe, stable operations.

- (1) Flame current check
- (2) Ignition spark response test
- (3) Pilot turn-down test
- (4) Safety break check
- (5) Operation check indicator lamp (red)

#### (1) Flame current check

Checking the flame current is the best method of judging the mounting position of the flame detector. Check the flame current at installation and each time maintenance work is done. Check it at least once every month to prevent problems caused by shortage of the flame detection signal.

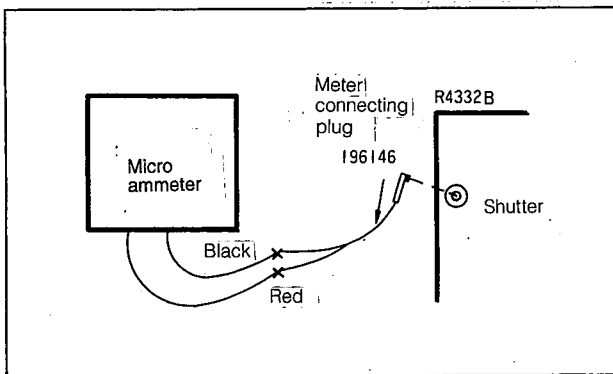

Fig. 8 Flame Current Measurement Method

For measurement of the flame current, connect the micro-ammeter lead (red or black) to the same color lead wire on the meter connection plug (196146), and inset the plug into the R4332B test jack.

Then operate the burner and read the flame current. (See Fig. 8.)

Check for the following when measuring the flame current:

- ① The flame current value must be stable within the range specified in Table 1.
- ② The meter deflection should not be higher than necessary.

If a stable flame current cannot be obtained it may be due to one of the following:

- Unsuitable supply voltage
- Disconnection of the flame detector
  - Open condition
  - Shorted condition
  - High resistance short circuit of lead wires due to moisture or contamination
  - Insulation deterioration at (F), (FS) and (G) terminals
- Unsuitable monitoring position and window
- Contamination of the light receiving face of UV flame detector
- UV flame detector trouble

#### (2) Ignition spark response test

Flame relay (K<sub>2</sub>) should not be excited by the spark generated during operation of the ignition transformer.

Check the response of the flame detector to an ignition spark by the following procedure, (also check the mounting position):

- (1) Shut off the fuel by closing the manual fuel valves for the pilot and main burners.
- (2) Turn on the power and start the equipment by increasing the set point of the controller or by turning on the start/stop switch.
- (3) The ignition transformer generates a spark between the ignition electrode and the flame ground.
- (4) Make sure that the flame relay is not energized.
- (5) If the flame relay is energized, relocate the flame detector or ignition electrode.

Table 1 Flame Current Value (recommendation)

Flame detector	Amplifier	Minimum* current value	Maximum current value	The flame current value is unstable or weak.
C7012E/F	R7247C	2 $\mu$ A	5 $\mu$ A	Make sure the flame is adjusted normally. Check the lens and monitoring window for contamination. Make sure the detector voltage and monitoring positions are normal.
C7076A/D	R7476A	2 1/2 $\mu$ A	5.5 $\mu$ A	Make sure the flame is adjusted normally. Check the lens and monitoring window for contamination. Make sure the monitoring position and detector voltage are normal. Make sure the detector sensitivity control is preset normally.

\* When the flame detector is mounted in the correct position, a strong, minimum signal is easily obtained. Be sure to secure the values specified above after the trial run.

### (3) Pilot turn-down test

**Caution:**

The pilot turn-down test should be conducted by an experienced professional only.

The test is made to confirm that the flame is transferred to the main burner when the pilot flame has been detected, even if the gas and air pressure have altered unfavorably.

The test must be performed as follows.

- ① Shut off the gas by closing the manual valves in the pilot and main passages.
- ② Connect a manometer to the downstream of the pilot solenoid valve.
- ③ Open the manual valve of the pilot passage.
- ④ Start operating the equipment by increasing the controller setting. Relay  $K_1$  is energized to open the pilot valve, and the ignition action is started.
- ⑤ Close the manual valve of the pilot passage slowly. The pilot flame will gradually diminish. Reduce it gradually until it is no longer detectable by the flame detector. Flame relays  $K_2$  and  $K_1$  turn off, the pilot solenoid valve closes, and the manometer pressure abruptly drops. Record the pressure just before the pilot solenoid valve is closed.
- ⑥ Restart the equipment.
- ⑦ Gradually open the manual valve of the pilot passage again, and set it to the pressure just before the shut off measured in step 5.
- ⑧ Make sure that the main burner is ignited smoothly and instantly when opening the manual valve of the main passage.
- ⑨ Change the gas pressure to the minimum and maximum, and repeat the ignition to the main burner 5 to 6 times. Make sure that ignition is smooth and instantaneous each time.
- ⑩ If the main burner does not ignite, the pilot flame is too small. In such a case, perform the following adjustment after increasing the pilot flame.
  1. Separate the monitoring line of the flame detector slightly from the pilot flame axis, or insert a restrictor for correction.
  2. Pull out the flame rod slightly from the center of the pilot flame.
- ⑪ After adjustment, repeat steps ⑤ to ⑩, and make sure that the main burner is ignited.
- ⑫ After the test is complete, reset the manual valve in the main passage to the fully open position. Make sure that the flame current is okay.
- ⑬ Disconnect the manometer.

**Caution:**

If this test must be repeated several times, completely stop the equipment once and fully exhaust unburned gas and oil from the combustion chamber and stack before resuming testing.

**Caution:**

Make sure that the UV flame detector does not detect an ignition spark yet.  
If it does, relocate the UV flame detector or the ignition electrode.

### (4) Complete shutoff check

- ① Limit operation check  
Normal shutoff operation can be done during simulated operation of the burner by lowering the high-limit level of the boiler or furnace. Reset the high-limit setting afterward and the burner will be started again.
- ② Flame failure check  
Extinguish the burner flame by closing the manual fuel valve during burner operation. Make sure that the main and pilot valves are closed after the flame response time.

**Caution:**

Stop the burner artificially, and make absolutely sure that the R4332B functions normally.

### (5) Operating conditions of indicator lamp (red)

- ① When no flame exists:  
The lamp shines faintly.
- ② When a flame exists:  
The lamp flickers 1 to 2 times/minute when the R7247C and the C7012E/F are used.  
The lamp flickers about 75 times/minute when the R7476A and the C7076 are used.  
(These all indicate a proper flame current.)

### (6) Measurement of insulation at (F), (FS) and (G) terminals

- ① Disconnect all amplifiers from the main unit.
- ② Disconnect the flame detector cable on the detector side.
- ③ Measure the insulation of the following terminals by using a 500 V DC megger:  
Between (F<sub>1</sub>) and (F<sub>2</sub>), (FS<sub>1</sub>), (FS<sub>2</sub>), (G) (etc.) terminals  
Between (F<sub>2</sub>) and (FS<sub>1</sub>), (FS<sub>2</sub>), (G) terminals  
Between (FS<sub>1</sub>) and (FS<sub>2</sub>), (G) terminals  
Between (FS<sub>2</sub>) and (G) terminals
- ④ The insulation resistance should be higher than 100 MΩ.

# 6.

# MAINTENANCE

## 1. General Maintenance

### Caution:

- Maintenance must be performed by an experienced professional.
- Perform all checks in accordance with the items in section 5 after any necessary equipment has been replaced and fully shut off.
- Make sure each controller is operated normally during on-site maintenance and service.
- Don't lubricate any part of the flame safeguard multiburner module.
- Clean the flame detector when cleaning the burner.

## 2. Maintenance frequency

Determine the maintenance and check cycles according to the equipment, ambient conditions at the mounting site (presence of dust, ambient temperature, etc.) and the extent of shutoff damage caused by trouble during operation.

- (1) Be certain to perform the pilot turn-down test when burner maintenance and checks have been completed. Perform this test at least once a year.
- (2) Check the burner shutoff once a month.
- (3) Check the flame detector for contamination of the monitoring window and for ambient temperature. Clean the window if necessary.
- (4) Measure the flame current at least once a month.  
When operations are damaged due to a shutoff, check the equipment frequently, and measure the insulation of the (F), (FS) and (G) terminals.

## 3. Troubleshooting

Observe the following procedure if trouble with the equipment occurs:

- (1) Set the equipment so that the limit switch is on.
- (2) Turn the power switch on.
- (3) Make sure voltage is applied between terminals (L<sub>1</sub>) and (L<sub>2</sub>). The voltage should be within  $\pm 15\%$  of the rated voltage.

### Caution:

**The specified voltage is simultaneously applied to almost all of the terminals when the power is turned on. Be careful when trouble shooting.**

## 4. Check the flame

- (1) If the flame current is lower than the value specified in Table 1, check the insulation resistance of the (F), (FS) and (G) terminals.
- (2) Proceed to item 5, if the K<sub>2</sub> relay is not energized.
- (3) Check the false flame phenomenon when the K<sub>2</sub> relay is energized.
  - ① Replace the amplifier if the K<sub>2</sub> relay is still energized after disconnecting the cable from the flame detector.
  - ② If the K<sub>2</sub> relay is not energized even after disconnecting the cable, the flame detector or external circuit is faulty. Check them.

## 5. Check to see if the 1K relay is energized.

- (1) If it is energized, and the pilot ignites when pushing the START button, proceed to item 8.
  - (2) If K<sub>1</sub> relay is not energized, proceed to item 6.
  - (3) If ignition action is not started, proceed to item 7.
6. If the K<sub>1</sub> relay is not energized, turn on the limit switch and check the voltage between terminals (L<sub>2</sub>) and (31) again. Replace the K<sub>1</sub> relay, if the rated voltage appears.
  7. Check the voltage between terminals (L<sub>2</sub>)—(71) if ignition is not the cause for the burner starting failure even when the K<sub>1</sub> relay is energized.
    - (1) Replace the K<sub>2</sub> relay, because voltage is not flowing between terminals (L<sub>2</sub>) and (71).
    - (2) Check the burner, the ignition transformer and the fuel valve external connection circuit if the rated voltage is detected between terminals (L<sub>2</sub>) and (71). Check the following conditions which may cause ignition delay: connections, burner adjustment, ignition function (including the electrode interval and mounting position), oil quality and spray, fuel pressure, flame profile, flame quality, main burner pilot mounting position, flame detector, and others.

## Flame detection function

8. Observe the flame relay (K<sub>2</sub> relay) function when the burner has ignited.
  - (1) If the flame relay is energized, proceed to item 10.
  - (2) If the flame relay is not energized, proceed to item 9.
9. Check the flame relay action according to the following procedure.
  - (1) Check the flame current. (See Section 5.)
  - (2) Replace the amplifier if the flame current is sufficient.
  - (3) Check the items described in Section 5 if the flame current is insufficient.

### Sequence action observation

10. Check the main fuel valve action when the flame relay has been energized.  
Check the voltage between terminals (L<sub>2</sub>) and (N1) if the main fuel valve is not open.  
(1) Check the main fuel valve and its connection if the voltage is normal.  
(2) Replace the K<sub>2</sub> relay if no voltage appears.
11. Make sure that a spark by the ignition transformer connected to terminal (71) stops when the flame relay has been energized. If the spark does not stop, make sure the correction is normal. If not, replace the K<sub>2</sub> relay.

### Other phenomena

#### 12. Chattering of relays

Chattering of the K<sub>1</sub> relay may be caused by an abnormal drop in the power supply (check the voltage) or a loose terminal connection (tighten it).

Chattering of the K<sub>2</sub> relay may be caused by abnormal combustion (adjust the burner) or contamination of the monitoring section of the flame detector (clean it).

#### 13. When the UV alarm lamp lights up

This means that a flame is detected although a shutter close signal is output from the amplifier. This is likely caused by one of the following:

- ① The ultraviolet rays emitted from the flame are excessive.
- ② The amplifier (R7247C) is defective.

- ③ The C7012 internal shutter is defective in the open mode.
- ④ The wrong UV tube is being used.
- ⑤ X-rays or gamma rays are present.
  - (1) If ON-OFF operation is not performed regularly, regardless of the existence of a sufficient quantity of light, reduce the sighting of the flame detector so as to cut down on the light.
  - (2) Disconnect the leads (from the C7012E/F) from the F and G terminals of the main unit, and turn ON the start switch. After the ignition transformer operates, connect the F and G terminals of the flame simulator (121708 black), and turn ON-OFF this connection at the rate of 60 to 120 times per minute.  
If the UV alarm lamp does not light, the amplifier is normal.  
If it does light, the amplifier is defective and must be replaced.
  - (3) If the amplifier is normal, remove the cover of the C7012E/F gently, with the power ON, and check if the shutter is being kept open. If it operates at the rate of 60 to 120 times per minute, it is normal. If not, it is defective and must be replaced.
  - (4) If the shutter is normal, replace the UV tube, and reattach the case cover, and then operate the shutter.
  - (5) Check whether or not there is a potential source of any X-rays or gamma rays near the equipment.

## 7.

## SPECIFICATIONS

### Product Specification Information

#### 1. Model No.

Model No.	Power Supply voltage	Shutter voltage	Relay (K <sub>1</sub> , K <sub>2</sub> )	Number of Burners
R4332B 100-1	100 Vac	100 Vac	Standard relay	2 burners
R4332B 104-1	100 Vac	120 Vac	Standard relay	
R4332B 200-1	200 Vac	120 Vac	Standard relay	

#### Relay (K<sub>1</sub>, K<sub>2</sub>)

Type	Specification	Part No.	Contact Rating
Standard relay	K <sub>1</sub> relay 48 Vdc	81403124-048	200 V 3 A (resistance load)
	K <sub>2</sub> relay 24 Vdc	81403124-124	200 VA (inductive load)
Enclosed type relay	K <sub>1</sub> relay 48 Vdc	81403125-048	200 V 1 A (resistance load)
	K <sub>2</sub> relay 24 Vdc	81403125-024	100 VA (inductive load)

#### Devices to be connected in combination (amplifier and flame detector)

Type No.	Frame Response	Flame Current Range	Flame Detector
R7247C1001	2 to 4 s	2 to 7 μA	C7012E, F
R7476A1007	2 to 4 s	2.5 to 5.5 μA	C7076A, D

**Power Consumption:**

Per channel, 19 W max., 30 VA max. (including amplifier, flame detector)

**Allowable Voltage:**

85 to 110% of rated voltage

Power Frequency: 50 to 60 Hz

Ambient Temperature: -20 to +60 °C

Ambient Humidity: 90%RH max. at 40°C

Life: 100,000 cycles 8at room temperature, room humidity, rated voltage, and rated load)

**Insulation Resistance:**

More than 100 M ohms between each terminal and ground with a 500 Vdc megger (except F1, F2, FS1, FS2, G terminals).

**Dielectric Strength:**

No damage when 1500 Vac 50/60 Hz is applied for 1 minute or 1800 Vac is applied for 1 second between each terminal and ground (except F1, F2, FS1, FS2, G terminals). Before testing, the wiring of terminal G must be removed.

**Mass:**

About 4.0 kg (including two amplifiers)

Allowable Vibration: 4.9 m/s<sup>2</sup> 3600 rpm max. (for 2 h each in X, Y, and Z directions)

**Output Voltage of Test Terminal:**

Output voltage between G and FS is basically proportional to the flame current, but varies with external wiring length, input impedance of measuring equipment, and grounding condition. Use afterdue testing.

**Application Example 1**

**Flame Current**

Measurement ... W136 test meter (sales discontinued now) or an equivalent tester

**Output Voltage**

Measurement ... ① Meter Relay (Input impedance 100 KΩ)  
... ② Pen Recorder (Input impedance 1 MΩ)

Cable ... 5C2V\* (5 m)

Flame Detector ... C7012E

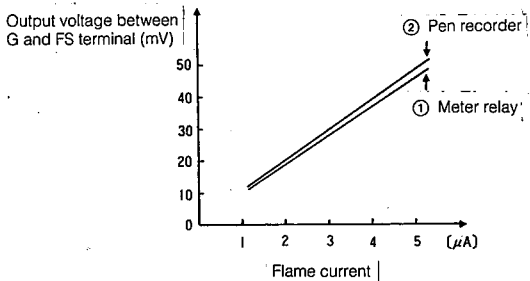

\*5C2V: JAN standard RG-11/U or equivalent.

**Application Example 2**

**Flame Current**

Measurement ... W136A test meter (sales discontinued now) or an equivalent tester

**Output Voltage**

Measurement ... ① Meter Relay (Input impedance 100 KΩ)  
... ② Pen Recorder (Input impedance 1 MΩ)

Cable ... 5C2V\* (5 m)

Flame Detector ... C7076A

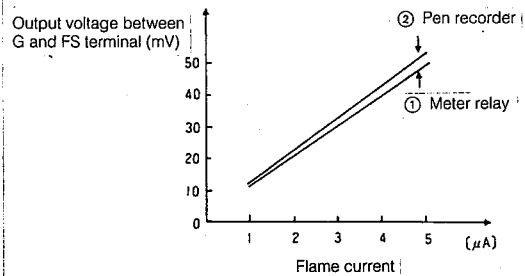

\*5C2V: JAN standard RG-11/U or equivalent.

**(Precaution):** Use a high frequency coaxial cable (5C2V or equivalent) within 5 m in length for the lead from the flame signal measuring terminals. If a longer cable is required to be used, insert a signal amplifier or transformer halfway to prevent the signal level from being attenuated. In this case, use a measuring instrument or recorder whose input impedance is 100 kΩ or more.

**YAMATAKE**

**Yamatake Corporation**  
**Advanced Automation Company**

Totate International Building  
2-12-19 Shibuya Shibuya-ku  
Tokyo 150-8316 Japan  
URL: <http://www.yamatake.com>

*This has been printed on recycled paper.* (02)

*Specifications are subject to change without notice.*

Printed in Japan.  
1st Edition: Issued in July, 1989  
5th Edition: Issued in Dec., 2004(B)