

# FRS100 Multiburner Control User's Manual



Thank you for purchasing the FRS100 Multiburner Control.

This manual contains information for ensuring the correct use of the FRS100. It also provides necessary information for installation, maintenance, and troubleshooting.

This manual should be read by those who design and maintain equipment that uses the FRS100. Be sure to keep this manual nearby for handy reference.

Yamatake Corporation

---

---

## RESTRICTIONS ON USE

---

---

This product has been designed, developed and manufactured for general-purpose application in machinery and equipment.

Accordingly, when used in applications outlined below, special care should be taken to implement a fail-safe and/or redundant design concept as well as a periodic maintenance program.

- Safety devices for plant worker protection
- Start/stop control devices for transportation and material handling machines
- Aeronautical/aerospace machines
- Control devices for nuclear reactors

Never use this product in applications where human safety may be put at risk.

---

---

### NOTICE

---

---

Be sure that the user receives this manual before the product is used.

Copying or duplicating this user's manual in part or in whole is forbidden. The information and specifications in this manual are subject to change without notice.

Considerable effort has been made to ensure that this manual is free from inaccuracies and omissions. If you should find an error or omission, please contact Yamatake Corporation.

In no event is Yamatake Corporation liable to anyone for any indirect, special or consequential damages as a result of using this product.

---

---

©1999 Yamatake Corporation ALL RIGHTS RESERVED

# SAFETY PRECAUTIONS

## ■ About Icons

The safety precautions described in this manual are indicated by various icons. Please be sure you read and understand the icons and their meanings described below before reading the rest of the manual.

Safety precautions are intended to ensure the safe and correct use of this product, to prevent injury to the operator and others, and to prevent damage to property. Be sure to observe these safety precautions.



### **WARNING**

Warnings are indicated when mishandling this product might result in death or serious injury.



### **CAUTION**

Cautions are indicated when mishandling this product might result in minor injury to the user, or only physical damage to the product.

## ■ Examples

	Triangles warn the user of a possible danger that may be caused by wrongful operation or misuse of this product. These icons graphically represent the actual danger. (The example on the left warns the user of the danger of electric shock.)
	White circles with a diagonal bar notify the user that specific actions are prohibited to prevent possible danger. These icons graphically represent the actual prohibited action. (The example on the left notifies the user that disassembly is prohibited.)
	Filled-in black circles instruct the user to carry out a specific obligatory action to prevent possible danger. These icons graphically represent the actual action to be carried out. (The example on the left instructs the user to remove the plug from the outlet.)

# **WARNING**



Before removing, mounting or wiring the FRS100, be sure to turn the power OFF. Failure to do so might cause electric shock.



Do not touch the terminals on this control. Doing so might result in an electric shock.



This control is for batch operation (at least one start and stop in 24 hours of operation) that utilizes the start check function.

Do not use this control for continuous operation (combustion for 24 hours or longer). Instead, use a self-checking Protectorelay (AUR300, AUR350, AUR450, or R4332B, etc.), which continuously checks the flame detector and flame detector circuit, and use a compatible flame detector (AUD300, or C7076, etc.).



This control does not have the prepurge timing and sequencing functions necessary for burner ignition. Take timer and sequence functions into consideration when designing your control system.



Do not connect the solenoid valve to the voltage side. If a ground fault occurs, ground current will flow to the solenoid valve and open it, causing fuel to flow regardless of the state of this control.



Prevent the pilot and main burner ignition times from exceeding the burner ignition time which the equipment manufacturer specifies. Excessively long ignition time might cause fuel to accumulate in the combustion chamber and an explosive air-fuel mix to form, resulting in the risk of a serious explosion.



Before carrying out the pilot turndown test or ignition spark response test, be sure that all manual fuel valves are closed.



Do not operate the control without completing the tests described in this chapter and the tests specified by the equipment manufacturer.



If the flame detector is set so that it detects a pilot flame that is too small to ignite the main burner, this control will not be able to recognize a flame failure in the main burner. In this case, fuel would continue to be supplied, causing a serious explosion hazard. Be sure to carry out the pilot turndown test carefully.



If the pilot turndown test must be carried out repeatedly, completely shut down all equipment each time the test is finished, and completely discharge unburned gas or fuel that has accumulated in the smoke ducts and combustion chamber. Failure to discharge unburned gas or fuel may result in an explosion.

# **WARNING**



After the pilot turndown test is completed, turn the power switch OFF to turn the power OFF. Be sure to restore all test jumper leads, limit switches and control settings used in the test to their original settings. If this control is operated without these components restored, it might be damaged, or a gas leak or explosion might result.



Do not touch terminal F or the flame detector cable connected to terminal F. Failure to pay attention to this warning might cause electric shock. An electric charge remains in the terminal F and the connected signal cable even after the power is turned OFF.

# **CAUTION**



Make sure that the ultraviolet flame detector cannot detect UV rays emitted by sources other than the burner. If the ultraviolet flame detector responds to other UV sources, it will judge that there is a flame even if the burner flame is out. As a result, fuel will continue to be supplied, causing a very serious explosion hazard.



This control has extremely important functions for safe operation of equipment. Follow the instructions in the user's manuals to ensure safe use.



Do not transport this control while it is mounted on a DIN rail. Before transporting the control, remove it from the subbase and pack it in its original packing case. If this control is transported on a DIN rail, it might fall off and be damaged.



Mounting, wiring, maintenance, inspection and adjustment should be carried out by a specialist who has been trained in how to handle burners and combustion safeguard equipment.

















Do not mount this control in the following locations:

- Near corrosive chemicals or gases (ammonia, sulfur, chlorine, ethylene compounds, acid, etc.)
- Where subject to water spray or extreme humidity
- Where subject to high temperatures
- Where subject to continuous vibration for a long time



After wiring, be sure to check the wiring connections. Operating this control with wires wrongly connected might cause damage or malfunction.

# CAUTION

	Be sure to wire the power supply last of all. Touching terminals by mistake with the power ON might cause an electric shock or malfunction.
	Make sure that the loads connected to the terminals do not exceed the specified ratings.
	Make sure that power of the same voltage and frequency as indicated on the model number label is supplied to the control.
	When configuring control circuits, select reliable timers and auxiliary relays as necessary for additional functions.
	Be sure to ground this control using a lead with a resistance of less than 100Ω, and be sure to ground the burner body.
	Bundle power leads, ignition transformer high-voltage cables and flame detector power leads separately from each other.
	Make sure that ignition transformer high-voltage cables are bundled separately. Keep these cables at least 10cm away from this control.
	Connect the blue signal lead from the Minipeeper Ultraviolet Flame Detector to terminal 5 and the white lead to terminal 6. If the power is turned ON with the Minipeeper Ultraviolet Flame Detector wired wrongly, the UV tube might be damaged.
	When equipment is restarted after the safety shutoff, check all items described in Chapter 4, ADJUSTMENTS FOR TRIAL OPERATION.
	Before carrying out maintenance and inspection on the burner, be sure to carry out the pilot turndown test. Carry out this test at least once every year.
	When cleaning the burner, clean the flame detector also.
	When mounting or wiring, be sure to follow the instructions in this user's manual and manuals provided by the equipment manufacturer or other device manufacturers.
	Follow all applicable regulations when wiring.
	Make sure that ignition transformer high-voltage cables are properly connected to prevent faulty contact. Faulty contacts might generate high-frequency radio waves, resulting in noise in radios or other electrical appliances, or causing malfunction.
	Connect the ignition transformer ground lead directly to the burner body, or to a metal part that is electrically connected to the burner body.

# Conventions Used in This Manual

---

The following conventions are used in this manual:

 **Handling Precautions:**

Handling Precautions indicate items that the user should pay attention to when handling the FRS100.

 **Note:**

Notes indicate information that might benefit the user.

(1), (2), (3):

Numbers within parentheses indicate steps in a sequence or parts of an explanation.

---

## SAFETY PRECAUTIONS

### Conventions Used in This Manual

## Chapter 1. OVERVIEW AND PRODUCT CONFIGURATION

■ Overview.....	1-1
■ Features.....	1-1
■ Model listing.....	1-1
■ Names of parts.....	1-2
■ Configuration .....	1-2

## Chapter 2. MOUNTING AND WIRING

2-1 Mounting and Wiring the Subbase.....	2-1
2-2 Wiring.....	2-4
■ Wiring overview .....	2-5
■ Wiring the flame detector.....	2-6
■ Wiring the solenoid valve .....	2-7
■ Wiring the surge absorber .....	2-8

## Chapter 3. EXPLANATION OF OPERATION

■ Manual ignition (intermittent pilot).....	3-1
■ Burner flame monitoring.....	3-3

## Chapter 4. ADJUSTMENTS FOR TRIAL OPERATION

■ Outline .....	4-1
■ How to measure the flame signal.....	4-2
■ Pilot turndown test .....	4-3
■ Ignition spark response test.....	4-5
■ Safety shutoff test .....	4-6

## Chapter 5. MAINTENANCE AND INSPECTION

■ Inspection cycle.....	5-1
■ Troubleshooting .....	5-2

## Chapter 6. SPECIFICATIONS

■ Specifications .....	6-1
■ External dimensions.....	6-2

# Chapter 1. OVERVIEW AND PRODUCT CONFIGURATION

## ■ Overview

The FRS100 Multiburner Control features built-in safe-start circuitry. To ensure safety, this circuitry prevents ignition if a failure is detected at startup, and shuts off the fuel line if the flame is interrupted during operation. Combined use with an ultraviolet flame detector or flame rod enables batch operation of burners.

## ■ Features

- The start check function inspects the flame detector and flame relay body at startup to ensure safe operation. If an abnormality is found, ignition is prevented.
- The controller is designed to be compact, and can be plugged into the wiring sub-base. The sub-base can be mounted by screws or onto a DIN rail.
- The power supply state and ignition detection can be read easily from the LEDs on the front display. Completion of the start check is indicated by the LED on the center of the body behind the front cover.
- Flame voltage output (0 to 5Vdc) can be checked at the dedicated terminal by a general-purpose tester, or continuously monitored by a panel meter or recorder.
- The controller has a dedicated connector so that the optional FRS60A Flame Meter can be attached.

## ■ Model listing

Model	Model No.	Rated Power Supply	Power Consumption	Flame Failure Response	Flame Detector		
Standard model	FRS100B100	100Vac 50 / 60Hz	3W max.	3 ±1s (flame voltage 2V)	Flame Rod C7007A, C7008A		
	FRS100B200	200Vac 50 / 60Hz		2s max. (flame voltage 2V)		Ultraviolet Flame Detector C7012A, C7012C	
	FRS100B104	100Vac 50 / 60Hz			7W max.		3 ±1s (flame voltage 4.2V)
	FRS100B204	200Vac 50 / 60Hz		2s max. (flame voltage 4.2V)			
	FRS100C100	100Vac 50 / 60Hz	7W max.			3 ±1s (flame voltage 3.5V)	
	FRS100C200	200Vac 50 / 60Hz		2s max. (flame voltage 3.5V)			
	FRS100C104	100Vac 50 / 60Hz			7W max.	3 ±1s (flame voltage 3.5V)	
	FRS100C204	200Vac 50 / 60Hz		2s max. (flame voltage 3.5V)			
High-sensitivity model	FRS100C150	100Vac 50 / 60Hz	7W max.		3 ±1s (flame voltage 3.5V)		
	FRS100C250	200Vac 50 / 60Hz		2s max. (flame voltage 3.5V)			
	FRS100C154	100Vac 50 / 60Hz			7W max.		3 ±1s (flame voltage 3.5V)
	FRS100C254	200Vac 50 / 60Hz		2s max. (flame voltage 3.5V)			

■ Names of parts

● FRS100 body

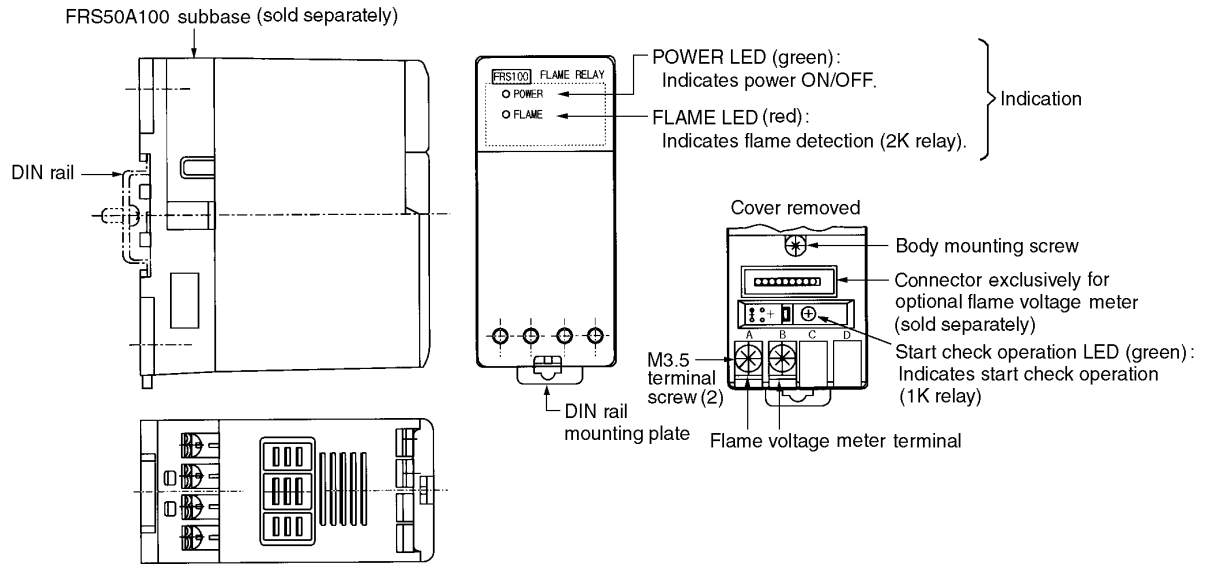

● FRS50A100 subbase (sold separately)

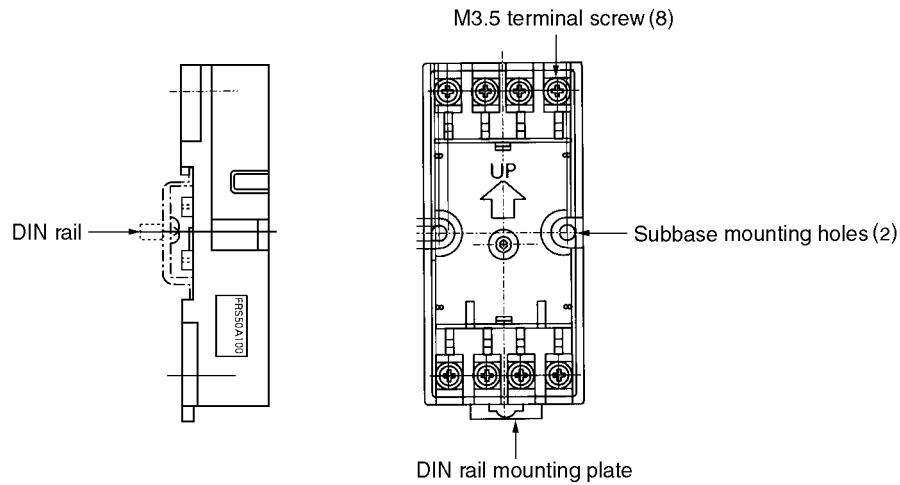

■ Configuration

● Flame Detector

FRS100B

Name	Model No.
Ultraviolet Flame Detector	C7012A/C
Flame Rod	C7007A, C7008A

FRS100C

Name	Model No.
Minipeeper Ultraviolet Flame Detector	C7035A, C7027A

● Optional Parts (sold separately)

Name	Model No.	Name	Model No.
Subbase	FRS50A100	Flame Meter	FRS60A
Flame simulator for C7035A, C7027A	123514B	Flame Simulator for Flame Rod	123514A, 121708
Lightning surge absorber	83968019-001		

# Chapter 2. MOUNTING AND WIRING

## 2 - 1 Mounting and Wiring the Subbase

### ⚠ CAUTION

- ⊘ Do not mount this control in the following locations:
  - Near corrosive chemicals or gases (ammonia, sulfur, chlorine, ethylene compounds, acid, etc.)
  - Where subject to water spray or extreme humidity
  - Where subject to high temperatures
  - Where subject to continuous vibration
- ⊘ Do not transport this control while it is mounted on a DIN rail. Before transporting the control, remove from the subbase and pack it in its original packing case. If the controller is transported on a DIN rail, it might fall off and be damaged.
- ! When mounting or wiring, be sure to follow the instructions in this user's manual and manuals provided by the equipment manufacturer or other device manufacturers.

#### ● Mounting location

Maintain space around the control as shown below for heat radiation, and to facilitate mounting, removal, wiring and maintenance.

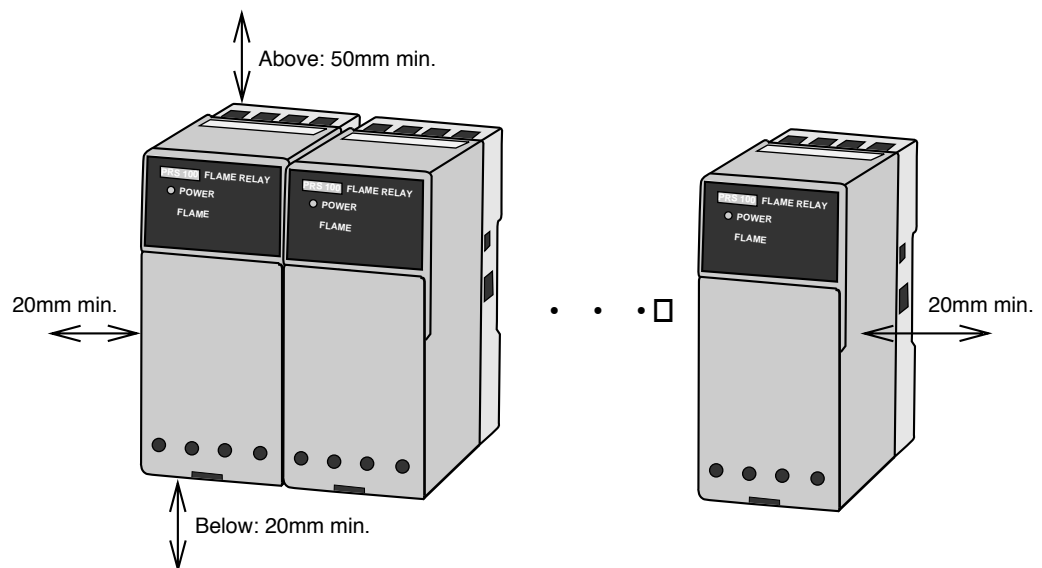

#### ! Handling Precautions

- If there is room, leave as much space as possible between the FRS and other FRS units to allow for heat radiation.
- If ambient temperature is close to the allowable upper limit, reduce the internal temperature of the control panel by mounting a panel cooler or a cooling fan.

Allowable ambient temperature upper limits

- Gang-mounting: 45°C
- Stand-alone mounting: 60°C

● **Mounting direction**

- Mount so that the arrow on the subbase is facing upwards.

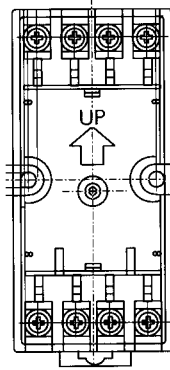

- Mount so that the display panel is in front.

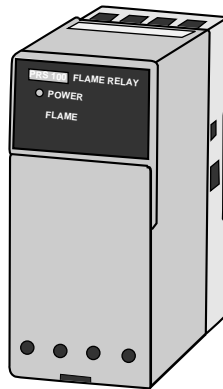

● **DIN rail mounting**

- (1) Pull the DIN rail fixing plate downwards.
- (2) Place the controller on the DIN rail so that the arrow on the subbase is facing upwards.
- (3) Press in the DIN rail fixing plate to fix onto the DIN rail.
- (4) Wire the subbase terminals as instructed in **2-2 Wiring**.
- (5) Pull the bottom of the controller cover downwards to remove.
- (6) Press the controller into the subbase with the display facing upwards.
- (7) Tighten the mounting screw on the center of the body to fix onto the subbase with a maximum torque of 0.3N·m.
- (8) If necessary, wire the flame voltage meter terminal.
- (9) Mount the cover on the control body.

---

**● Direct panel mounting**

- (1) Drill two M4 mounting holes in the panel so that the arrow on the subbase will be facing upward.

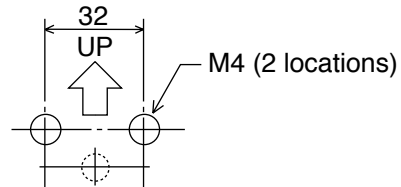

- (2) Attach the two mounting holes on the subbase to the panel using two M4 screws at a maximum torque of 0.7N·m.
- (3) Wire the subbase terminals as instructed in 2-2 Wiring.
- (4) Pull the bottom of the controller cover downwards to remove.
- (5) Press the controller into the subbase with the display facing upwards.
- (6) Tighten the mounting screw on the center of the body to fix onto the subbase with a maximum torque of 0.3N·m.
- (7) If necessary, wire the flame voltage meter terminal.
- (8) Mount the cover on the control body.

**! Handling Precautions**

- Do not tighten the subbase mounting screws using a torque exceeding the maximum torque.

## 2 - 2 Wiring

### WARNING



Wire external leads between the power supply terminals (100V, or 200V and 0V) of this control so that power is supplied at all times from the moment the power switch is turned ON. This wiring is necessary to ensure operation of the self-test circuits at startup.

### CAUTION



When mounting or wiring, be sure to follow the instructions in this user's manual and manuals provided by the equipment manufacturer or other device manufacturers.



Follow all applicable regulations when wiring.



Before wiring, be sure to turn the power supply OFF. Touching terminals by mistake with the power ON might cause an electric shock or malfunction.



Make sure that the loads connected to the terminals do not exceed the ratings indicated in the specifications.



Make sure that power of the same voltage and frequency as indicated on the Model No. label is supplied to the controller.



When configuring control circuits, select reliable timers and auxiliary relays as necessary for use as additional functions.



Be sure to ground this control using a lead with a resistance of less than 100Ω, and be sure to ground the burner body.



Bundle power leads, ignition transformer high-voltage cables and flame detector leads separately from each other.



Keep ignition transformer high-voltage cables at least 10cm away from the flame relay.



Make sure that ignition transformer high-voltage cables are properly connected to prevent faulty contact. Faulty contacts might generate high-frequency radio waves, resulting in noise in radios or other electrical appliances, or causing malfunction.



Connect the ignition transformer ground lead directly to the burner body, or to a metal part that is electrically connected to the burner body.



After wiring, be sure to check the wiring connections. Operating the control with wires wrongly connected might cause damage or malfunction.

■ **Wiring overview**

● **Manual ignition (intermittent pilot)**

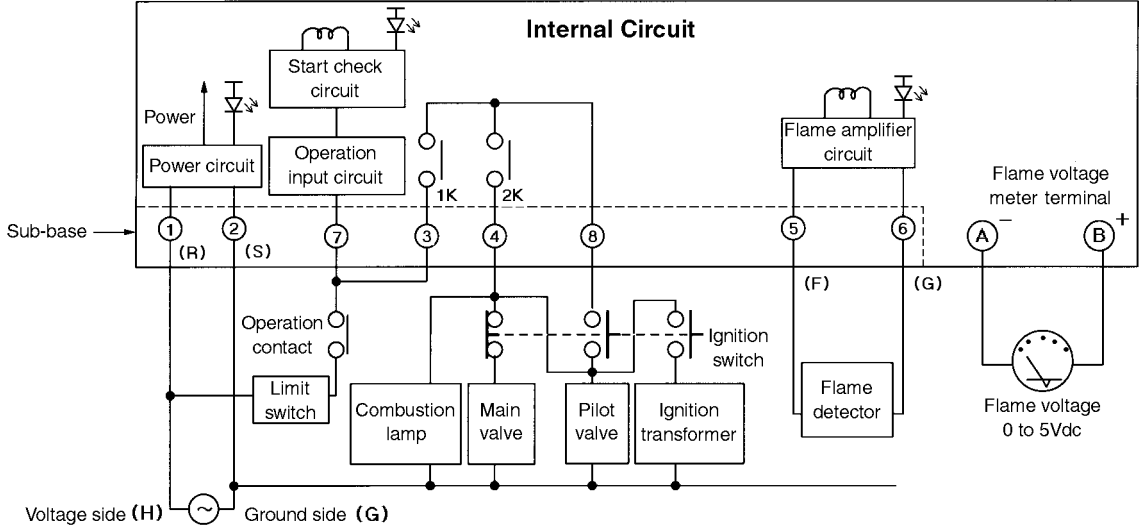

! **Handling Precautions**

- The power supply is marked H and G for the voltage and ground sides, respectively. Accordingly, connect the voltage side (H) to terminal 1 and the ground side (G) to terminal 2.

● **Burner flame monitoring**

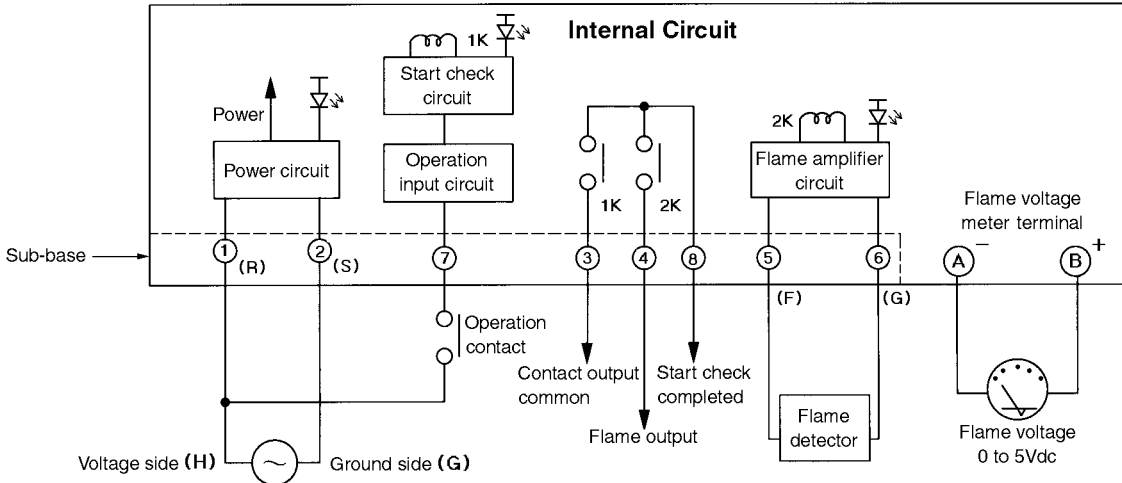

! **Handling Precautions**

- The power supply is marked H and G for the voltage and ground sides, respectively. Accordingly, connect the voltage side (H) to terminal 1 and the ground side (G) to terminal 2.

■ **Wiring the flame detector**

**⚠ CAUTION**



Connect the blue signal lead from the Minipeeper Ultraviolet Flame Detector to terminal 5 (F) and the white lead to terminal 6 (G). If the power is turned ON with these leads miswired, the built-in UV tube may be damaged.

● **Wiring between the C7035/C7027 Minipeeper Ultraviolet Flame Detector and the FRS100C**

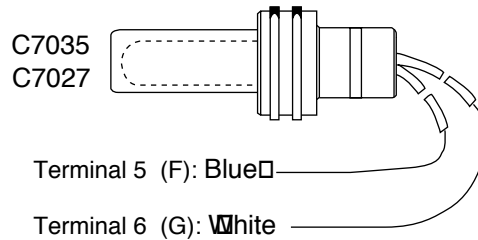

- Permissible lead length
  - Type of signal lead 2mm<sup>2</sup>, 600Vac IV (indoor vinyl) insulated power lead
  - Permissible lead length Approx. 200m

● **Wiring between the Flame Rod and the FRS100B**

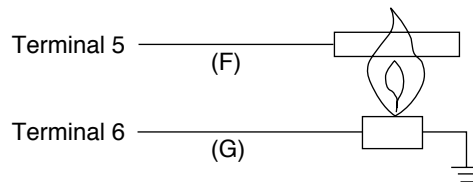

- Permissible lead length
  - Type of signal lead High-frequency coaxial cable 5C2V, 7C2V
  - Permissible lead length Approx. 30m

● **Wiring between the C7012A/C Ultraviolet Flame Detector and the FRS100B**

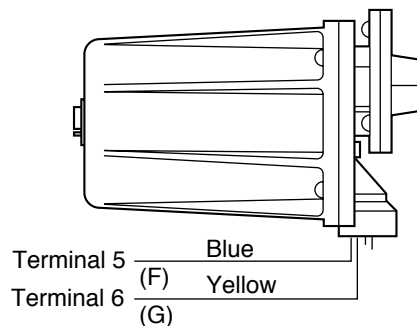

- Permissible lead length
  - Type of signal lead High-frequency coaxial cable 5C2V, 7C2V
  - Permissible lead length Approx. 50m

■ Wiring the solenoid valve

**⚠ CAUTION**

⊘ Do not connect the solenoid valve to the voltage side. If a ground fault occurs, ground current will flow to the solenoid valve and open it, causing fuel to flow regardless of the state of this control.

● Correct connection

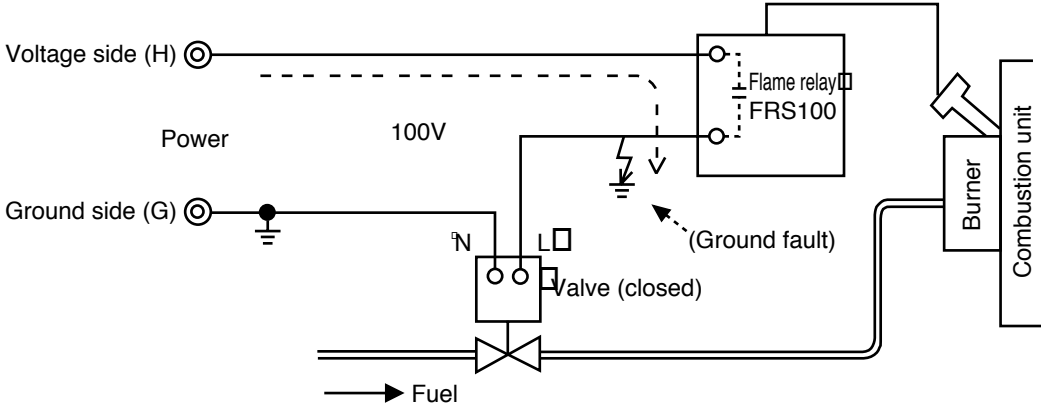

Ground current will not flow to the solenoid valve if the valve is wired as shown in the figure above, even if faulty insulation on the voltage side (H) causes a ground fault. Accordingly, the valve will not open, eliminating the risk of fuel discharge.

● Wrong connection

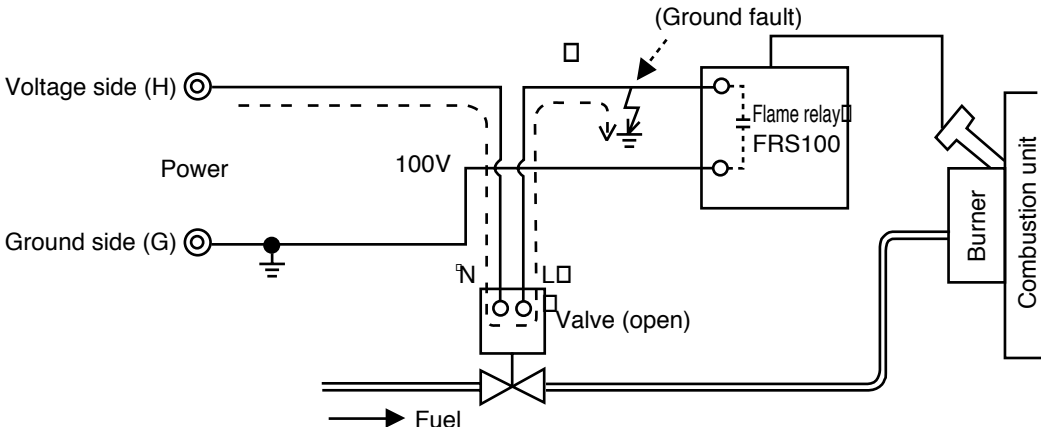

Ground current will flow to the solenoid valve if the valve is wired as shown in the figure above and if a ground fault occurs. Accordingly, the solenoid valve will open regardless of the flame relay, causing fuel discharge.

## ■ Wiring the surge absorber

Wire as shown below when using a surge absorber (model No.83968019-001, ordered separately) for protection from lightning surge.

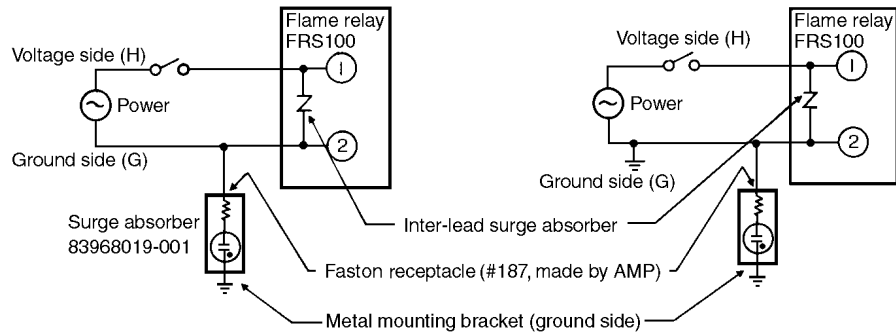

## ! Handling Precautions

- Use a JIS C 3306, 0.75mm<sup>2</sup> power lead (lead diameter 0.18, 30-strand) or higher for wiring to the power supply.
- Attach a Faston receptacle (#187, made by AMP) to one end of the power lead, and make the wire connection as short as possible.
- Ground the surge absorber mounting bracket by attaching to a grounded metal part such as the burner body.



● Operation

Operation	FRS100 Operation	Equipment State
Power switch ON, limit switch ON	<ul style="list-style-type: none"> <li>Power is applied across the 100V or 200V and 0V power terminals on the equipment (the POWER LED lights up).</li> </ul>	
Operation contact ON	<ul style="list-style-type: none"> <li>Start check is carried out by energizing terminal 7, and the 1K relay turns ON (the start check LED lights up). If there is a false flame, the 1K relay does not output to terminals 4 and 8 as it is not energized, and the ignition operation is not started.</li> </ul>	Ready for ignition.
Ignition switch ON (Do not leave ignition switch ON. Pilot burner normally lights in 5 to 10 seconds.)	<ul style="list-style-type: none"> <li>Voltage is applied to the pilot valve and ignition transformer from terminal 8, initiating each of their operations.</li> <li>When the flame detector detects the pilot burner flame, the 2K relay turns ON (the FLAME LED lights up).</li> </ul>	
Ignition switch OFF	<ul style="list-style-type: none"> <li>The pilot valve is held open from terminal 4 via the 1K and 2K contacts.</li> <li>The main valve is energized by resetting the ignition switch contact.</li> </ul>	Ignition transformer stops. Pilot valve opens. Main valve opens.
Operation contact	<ul style="list-style-type: none"> <li>The pilot valve, main valve and combustion lamp are de-energized and operation stops. (The start check LED and FLAME LED go out.)</li> </ul>	Pilot valve closes. Main valve closes. Combustion lamp out.
Flame failure	<ul style="list-style-type: none"> <li>The 2K relay becomes de-energized after the flame response; the combustion lamp goes out; the main valve closes; the pilot valve closes; and the equipment stands by for re-ignition. (the FLAME LED goes out.)</li> </ul>	Pilot valve closes. Main valve closes. Combustion lamp out.

■ Burner flame monitoring

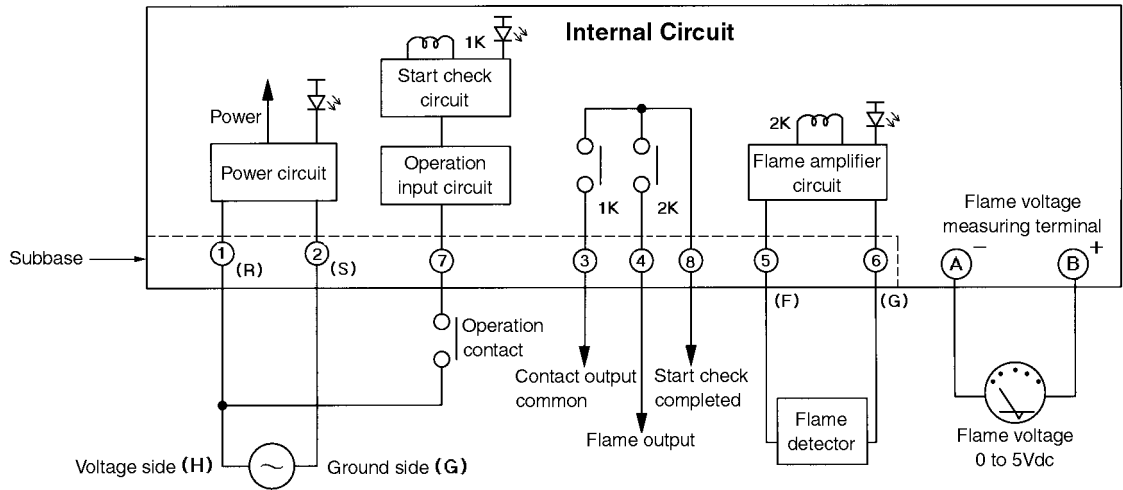

• Normal Operation

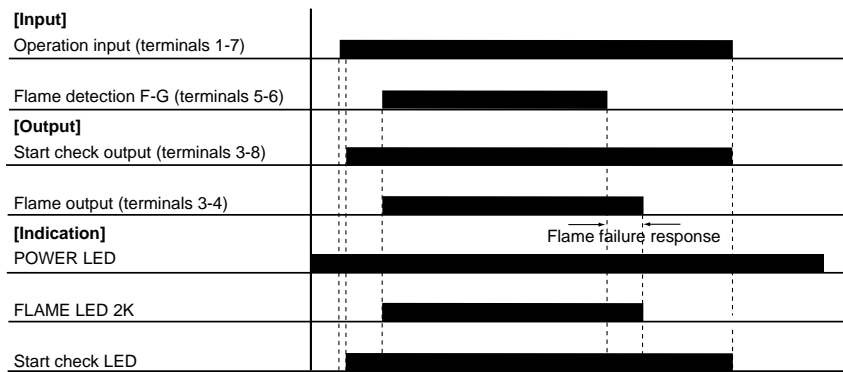

• False Flame Operation

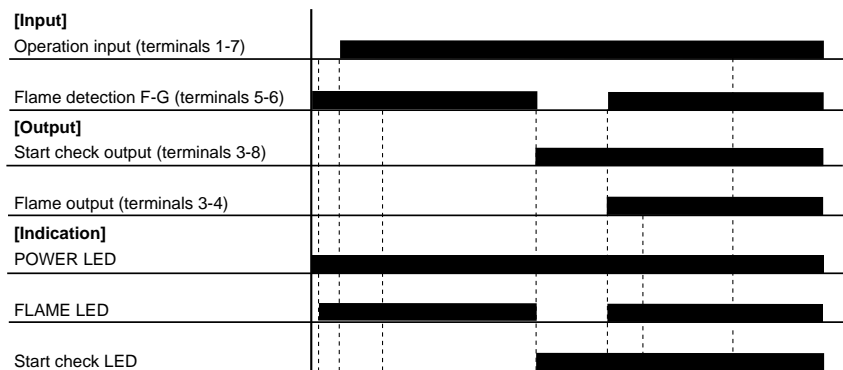





● Operation

- When the operation contact turns ON, the 1K relay turns ON at completion of the start check, and terminals 3-8 turn ON. (The start check LED lights up in sync with terminals 3-8 turn ON).
- When the flame is detected, the 2K relay turns ON, and terminals 3-4 turn ON. (The FLAME LED lights up in sync with terminals 3-4 turn ON).

# Chapter 4. ADJUSTMENTS FOR TRIAL OPERATION

## WARNING

-  Prevent the pilot and main burner ignition times from exceeding the burner ignition time which the equipment manufacturer specifies. Excessively long ignition time might cause fuel to accumulate in the combustion chamber and an explosive air-fuel mix to form, resulting in the risk of a serious explosion.
-  Do not touch the terminals during trial operation adjustments. Doing so might result in an electric shock.
-  Before removing or mounting the FRS100, be sure to turn the power OFF. Failure to do so might cause electric shock.
-  Before carrying out the pilot turndown test or ignition spark response test, be sure that all manual fuel valves are closed.
-  Do not operate the control without completing the tests described in this chapter and the tests of specified by the equipment manufacturer.

### ■ Outline

The following table shows the test adjustment items described in this chapter:

Item	Applicable Unit
Flame signal measurement method	All units
Pilot turndown test	Units using the pilot burner
Ignition spark response test	All units
Safety shutdown test	All units

### Handling Precautions

- After adjusting the above items, make sure that all of the adjustment requirements are satisfied. All of the adjustment requirements must be satisfied by the final mounting position of the flame detector.

#### ● Required items

- Tester (input impedance, 100k $\Omega$  or more)  
Range: 0 to 300Vac, 0 to 5Vdc
- Two jumper leads with crocodile clips, AWG14 (2mm<sup>2</sup>) or more, approximately 30cm long.
- Insulation tester: 500Vdc megger

#### ● Preliminary inspection

- Check all wiring locations.
- Make sure that the controller is mounted at a location within the permissible ambient temperature.
- Make sure that the flame detector is properly mounted.  
(For details, see the flame detector user's manual.)

- Disconnect the loads and flame detector wiring. Measure the insulation resistance across the terminals and panel ground, and make sure that the resistance is 50MΩ or more using an insulation tester or megger of 500Vdc or more.
- Valves and cocks on each of the fuel lines must be closed, and the fuel chamber must be thoroughly purged.

## ■ How to measure the flame signal

### ! Handling Precautions

- When the high-sensitivity model is used, limit the flame voltage to 4.5V.

- (1) Start the controller, and measure the flame voltage for each burner under various conditions (at startup, normal operation, etc.).
- (2) When measuring the flame voltage, insert the tester probes into the holes to connect to terminals A and B at the bottom front of the controller as shown below.

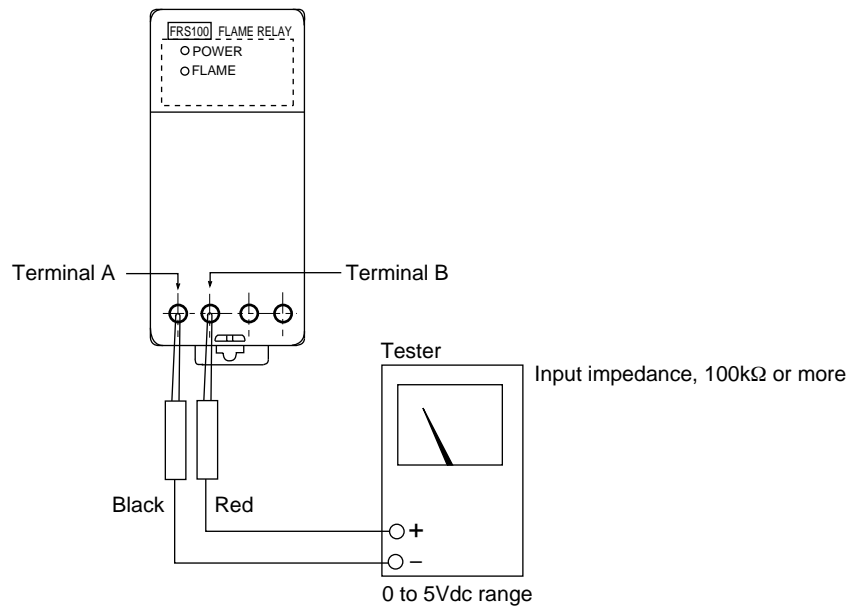

- (3) Refer to the following table for voltage values:



Recommended flame voltage	Checklist
2Vdc min.	<ul style="list-style-type: none"> <li>• Make sure that flame monitoring is correct.</li> <li>• The front of the flame detector must be free of dirt.</li> <li>• The monitoring tube must not be blocked with soot.</li> </ul>

- (4) If the flame signal fluctuates, check the flame detector mounting position and wiring again.

## ■ Pilot turndown test

This test is for checking that the pilot flame is transferred to the main burner when the flame detector detects the pilot flame, even if gas pressure and air pressure are at their worst.

### WARNING

-  If the flame detector is set so that it detects a pilot flame that is too small to ignite the main burner, this control will not be able to recognize a flame failure in the main burner. In this case, fuel would continue to be supplied, causing a serious explosion hazard. Be sure to carry out the pilot turndown test carefully.
-  If the pilot turndown test must be carried out repeatedly, completely shut down all equipment each time the test is finished, and completely discharge unburned gas or fuel that has accumulated in the smoke ducts and combustion chamber. Failure to discharge unburned gas or fuel may result in an explosion.
-  After the pilot turndown test is completed, turn the power switch OFF to turn the power OFF. Be sure to restore all test jumper leads, limit switches and control settings used in the test to their original settings. If this control is operated without these components restored, it might be damaged, or a gas leak or explosion might result.

### CAUTION

-  The pilot turndown test must be carried out by an experienced specialist having sufficient knowledge of burners and combustion safeguards.

## Handling Precautions

- If fuel pressure limit switches are open (in use) during this test, connect jumpers to set the limit switches ON.

### ● Procedure

- (1) Turn the power switch OFF.
- (2) Close the manual valve for the pilot and for the main burner to stop the gas flow.
- (3) Open the pilot manual valve.
- (4) Turn the power switch ON, followed by the start switch. Then press the ignition switch on the controller. The pilot will ignite and the pilot valve will open. Ignition will begin and the combustion lamp will light. Release the ignition switch.
- (5) Slowly close the pilot manual valve. The pilot flame will gradually grow smaller. Continue to close the manual valve until the flame detector can no longer detect the flame.  
Turn the 2K relay OFF, and write down what the pressure was immediately before the combustion lamp went out.

- (6) Slowly open the manual valve for the pilot until the pressure matches the pressure immediately before the combustion lamp went out. Then, press the ignition switch again to ignite the pilot.
- (7) Release the ignition switch.  
Make sure that the main burner ignites without any problem in one second or less when the main burner manual valve is opened.
- (8) Change the pressure from the minimum to the maximum value, and repeatedly ignite the main burner several times. Make sure that the main burner ignites without any problem every time.
- (9) If the main burner does not ignite properly, the reason is probably that the pilot flame is too small. Increase the size of the pilot flame, and carry out the following adjustment.
  - Either slightly take the monitor line of the flame detector away from the axis of the pilot flame, or stop the iris down to correct the visible flame size. (Set the flame size so that the main pilot ignites without problem at the minimum flame sensitivity.)
- (10) After making this adjustment, repeat steps 5 to 8, and make sure that main burner ignition is reliable.
- (11) When this test is completed, return the manual valve for the main burner to its fully open position. Then, make sure that the flame signal is appropriate.
- (12) Remove any jumper leads connected to limit switches during this test to restore to their original conditions.

## ■ Ignition spark response test

This test should be carried out on any equipment that uses an ultraviolet flame detector. The test is to check whether or not the ultraviolet flame detector responds to UV rays emitted from the ignition spark.

### ● Ultraviolet Flame Detector

#### CAUTION



Make sure that the ultraviolet flame detector cannot detect UV rays emitted by sources other than the burner. If the ultraviolet flame detector responds to other UV sources, it will judge that there is a flame even if the burner flame is out. As a result, fuel will continue to be supplied, causing a very serious explosion hazard.

Carry out the following test to check whether or not the ultraviolet flame detector or flame rod responds to the UV rays emitted from the ignition spark (so that the FLAME LED lights up).

- (1) Close the manual fuel valves of the pilot and main burner.
- (2) Start operation, and measure the flame voltage during the pilot ignition sequence to check for any influence from UV rays.
- (3) If the FLAME LED lights up, carry out the following adjustment, referring also to the equipment user's manual.
  - Move the position of the ultraviolet flame detector or ignition spark rod so that the ultraviolet flame detector is not influenced by UV rays.
  - Install a shield, for example, to prevent UV rays from the spark from entering the optical path of the ultraviolet flame detector, and adjust so that the influence of the spark on the flame voltage is 0.4Vdc or less.

● **Cautions Regarding UV Sources Other Than Flames**

The table below shows sources other than flames that emit UV rays that can be detected by the ultraviolet flame detector. Make sure that these UV sources do not influence operation of the ultraviolet flame detector under any operating conditions.

UV generating sources	1260°C or higher red-hot chamber wall
	Sparks • Ignition transformer    • Welding arc    • Lightning
	Gas laser
	Sunlamp
	Sterilizing lamp
	Strong flashlight (in direction of UV photoelectric tube)
Gamma ray and X-ray sources	Diffraction analyzer
	Electron microscope
	X-ray machine
	High-voltage vacuum switch
	High-voltage capacitor
	Radioactive isotope
	All other UV, gamma ray and X-ray sources

■ **Safety shutoff test**

Carry out the safety shutoff test when all operating adjustments have been completed.

- Pilot ignition failure (non-ignition)
  - (1) Close the manual fuel valves of the pilot and main burner.
  - (2) Press the ignition switch to start operation.
  - (3) The pilot valve opens upon pilot ignition. However, since the pilot cannot light, the FLAME LED does not light, and the main valve does not open.  
Do not continuously hold down the ignition switch.
  
- Flame failure during normal combustion
  - (1) Open the manual fuel valves of the pilot and main burner.
  - (2) Press the ignition switch to start operation.
  - (3) After the ignition sequence has proceeded normally, and the steady combustion cycle (main valve open) has begun, close the manual fuel valves for the pilot and main burner to turn the burner flame off. At this time, make sure that the flame failure is detected, and that the safety shutoff operates.

# Chapter 5. MAINTENANCE AND INSPECTION

## WARNING



Before removing or mounting the FRS100, be sure to turn the power OFF. Failure to do so might cause electric shock.



Do not touch the terminals on this control. Doing so might result in an electric shock.



Do not touch terminal F or the flame detector cable connected to terminal F. Failure to pay attention to this warning might cause electric shock. An electric charge remains the terminal F and the connected signal cable even after the power is turned OFF.

## CAUTION



Mounting, wiring, maintenance, inspection and adjustment should be carried out by a specialist who has been trained in how to handle burners and combustion safeguard controllers.



When the controller is restarted after the safety shutoff, check all items described in **Chapter 4, ADJUSTMENTS FOR TRIAL OPERATION**.



Before carrying out maintenance and inspection on the burner, be sure to carry out the pilot turndown test. Carry out this test at least once every year.



Periodically maintain and inspect the equipment as instructed in the equipment manufacturer's user's manuals.



When cleaning the burner, also clean the flame detector.

### ■ Inspection cycle

Determine an inspection cycle taking into consideration the following factors:

- Type of equipment
- Ambient conditions of installation site (dust, temperature, etc.)
- The effect of burner failure on equipment operation.

1. Carry out the safety shutoff test described in Chapter 4, ADJUSTMENTS FOR TRIAL OPERATION once per month.
2. Inspect the monitor window on the ultraviolet flame detector, the flame rod, etc. for dirt, and clean as necessary.
3. Check the temperature where the ultraviolet flame detector is installed.
4. Measure the flame voltage at least once per month to check its state. If equipment will be seriously damaged by a burner failure, carry out this inspection more frequently.

## ■ Troubleshooting

If a problem occurs, remove the front cover of the controller. Determine the operating state of the controller and type of trouble by checking the start check, POWER and FLAME LED display states. The start check LED is located in the center inside the cover, and the POWER and FLAME LEDs are located on the front display.

○ LED out

● LED lit

	POWER LED	Start check LED	FLAME LED	Results	Remedy (check items)
Before startup, terminal 7 OFF	○	○	○	The power is not ON.	Check panel power switch and wiring.
After startup, terminal 7 ON	●	●	●	The flame is being detected. (normal operation)	-
	●	●	○	The flame has not been detected.	Check flame detector, burner, flame relay, valves, ignition transformer and flame relay.*
	●	○	●	False flame	Check burner flame, flame detector and flame relay.*
	●	○	○	1K relay is not ON.	Check power supply at operation input terminal (7). Check flame relay.*

\* To check if the controller is operating correctly, apply a flame signal input to the controller by using a flame simulator. Make sure that 2K relay is turned ON and the FLAME LED is lit.

The following table shows the required flame voltages:

FRS100C	Standard model:	2V min.
	High sensitivity model:	3V min.
FRS100B	Standard model:	2V min.

### ● How to connect the flame simulator

- 123514A/B flame simulator  
Contact the terminal 5 lead wire to the probe end.  
Contact the terminal 6 lead wire to the plug end.
- 121708 flame simulator  
Contact the terminal 5 to the F lug.  
Contact the terminal 6 to the G lug.

### ⚠ Handling Precautions

- Keep the check time short and remove the simulator promptly after completion of the check.
- Do not touch the terminals F and G during operation or during the check. Doing so might cause electric shock.

# Chapter 6. SPECIFICATIONS

## ■ Specifications

Rated Power Supply	100Vac 50 / 60 Hz 200Vac 50 / 60 Hz
Allowable Voltage	-15 to +10% of rated voltage
Power Consumption	7W max.
Contact Rating	250Vac (across terminals 3-4, 3-8)
Flame Sensitivity	Ignition detection level: Flame voltage: 1V max. Flame-out detection level: FRS100B series flame voltage: 0.2V min. FRS100C series flame voltage: 0.4V min.
Flame Signal Output	Use at least 0.9mm <sup>2</sup> wire, a max. of 5m long, with IV (indoor vinyl) insulation. Output terminals: A (-) and B (+) on body Input impedance of externally connected equipment: 100kΩ min.
Ambient Temperature	Stand-alone mounting: -20 to +60°C Gang mounting (2 units or more): -20 to +45°C
Ambient Humidity	90% RH 40°C (condensation not allowed)
Vibration Resistance	4.9m/s <sup>2</sup> max., 10 to 60Hz for 2h each in X, Y and Z directions (when directly mounted on panel)
Insulation Resistance	50MΩ min. between terminals and ground terminal by 500Vdc megger
Dielectric Strength	No failure after applying 1500Vac for 1min or 1800Vac for 1s between terminals and ground terminal (excluding flame detector input of terminals 5 and 6)
Lightning surge	10kV, 1.2 x 50μs (JEC-187, surge impedance 75Ω or more) when the following surge absorber is attached to a power supply contact (terminal 2) and the ground terminal: • Recommended surge absorber: 83968019-001
Life	100,000 operations (at room temperature and humidity, and rated voltage)
Body Color	Gray
Mounting	Mounted on DIN rail or screw mounted (when using the FRS50A100 subbase)
Mass	FRS100B: Approx. 270g FRS100C: Approx. 270g FRS50A subbase : Approx. 70g
Optional Parts (sold separately)	Subbase Model No.: FRS50A100 Flame Simulator for C7035A, C7027A Model No.: 1231514B Lightning surge absorber Model No.: 83968019-001 Flame Meter Model No.: FRS60A Flame Simulator for Flame Rod Model No.: 123514A, 121708

■ External dimensions

- External dimensions when FRS100 is mounted on FRS50A100

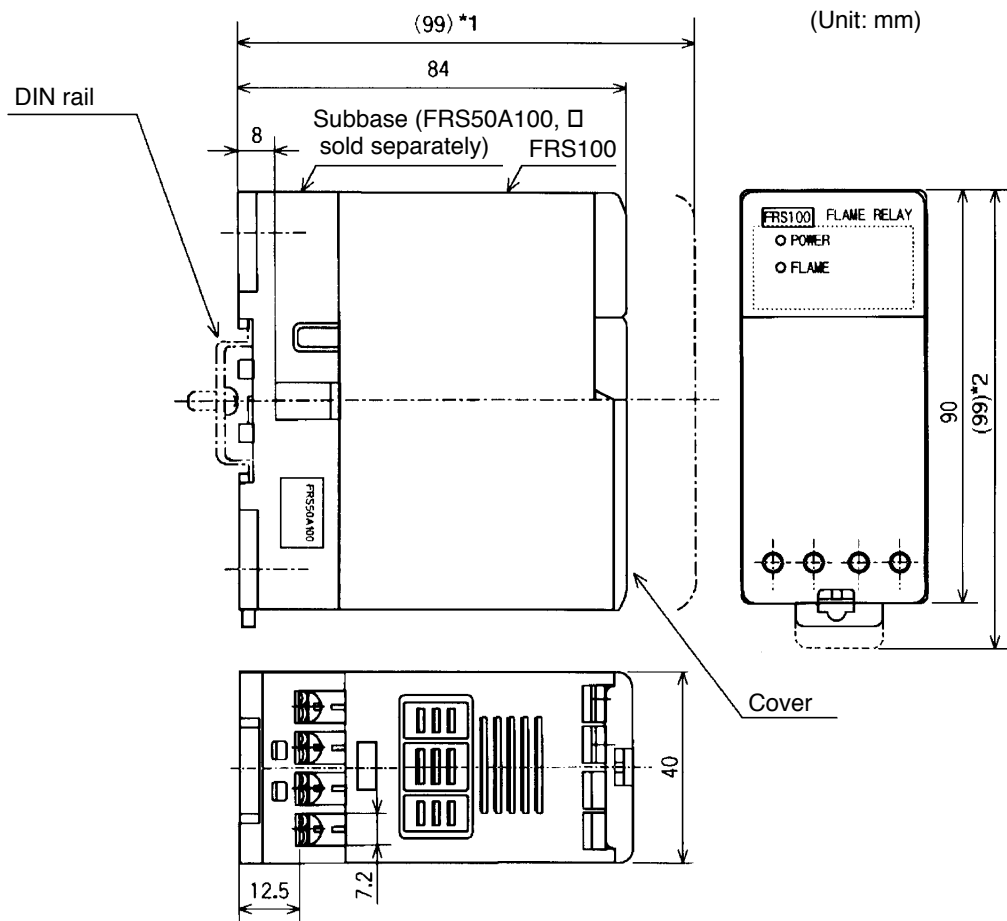

- \*1. Dimensions required for mounting and removing body
- \*2. Dimensions required for mounting and removing from DIN rail

● FRS50A100 subbase

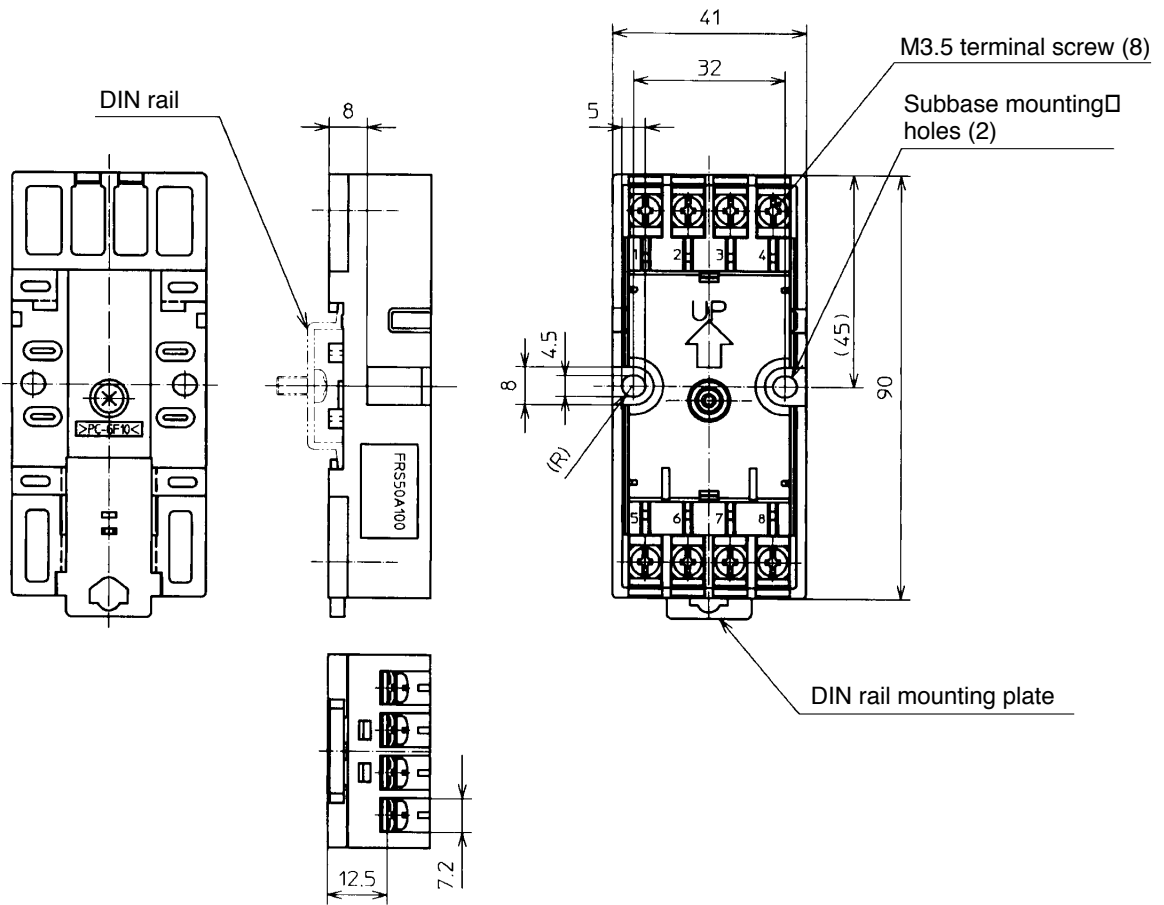

# Revision History

Printed date	Manual Number	Edition	Revised pages	Description
Oct. 1999	CP-SP-1074E	1st Edition		
Nov. 2000		2nd Edition	v 6-1	Unpacking deleted Power supply specifications added
May 2001		3rd Edition	2-1 5-2	Handling Precautions added How to connect the flame simulator added
Oct. 2001		4th Edition	i	About Icons changed
Apr. 2002		5th Edition	3-1 6-1	Output items corrected Pilot Valve,Main Valve→Pilot Valve,Main Valve Vibration Resistance Changed 5→4.9m/s <sup>2</sup>
Mar. 2003		6th Edition	4-2	RESTRICTIONS ON USE changed Insulation resistance corrected 100MΩ to 50MΩ
Feb. 2004		7th Edition	ii iii, 5-1	R4334A was deleted from the 3rd item One item was added to warning
Feb. 2005		8th Edition	2-6, 6-1 6-1	Class IV 2mm <sup>2</sup> changed into IV (Indoor Vinyl) 0.9mm <sup>2</sup> . Lightning surge: Specifications No.10013 deleted.
May 2005		9th Edition	2-6	IV (Indoor Vinyl) 0.9mm <sup>2</sup> →2mm <sup>2</sup> changed.
Dec. 2005		10th Edition	2-1	Handling Precautions changed.
May 2006		11th Edition	3-3	Normal operation : FLAME LED changed to FLAME LED 2K. Description on ● Operation changed
Aug. 2006		12th Edition	3-1	Circuit diagram corrected
Jan. 2007		13th Edition	ii	3rd item changed

**YAMATAKE**

**Yamatake Corporation**  
**Advanced Automation Company**

1-12-2 Kawana, Fujisawa  
Kanagawa 251-8522 Japan

URL: <http://www.azbil.com>

*Printed on recycled paper.* (07)

**azbil**

*Specifications are subject to change without notice.*

Printed in Japan.  
1st Edition: Issued in Oct. 1999 (K)  
13th Edition: Issued in Jan. 2007 (U)