

Flame Safeguard Control Multiburner Control Flame Relay FRS100

The FRS100 Flame Relay is a Flame Safeguard control with a self-checking circuit to ensure safe start-up operation. In the case where abnormal conditions exist, the ignition start is prevented and the system is secured by the shut down of combustion at main flame failure during operation.

This compact controller is used with a flame rod or a Minipeeper Ultraviolet Flame Detector for batch operation of combustion equipment, and can be mounted on a DIN-specification rail.



Specifications

Applications	Batch operation of oil-fired, gas-fired and oil-gas combination combustion equipment					
Flame Detector To be Used	FRS100B Series	Flame rod: C7007A, C7008A (wiring distance: 30m min, high frequency coaxial cable: 5C2V or 7C2V) Ultraviolet Flame Detector: C7012A, C (wiring distance: 50m max., high frequency coaxial cable: 5C2V or 7C2V)				
	FRS100C Series	Minipeeper Ultraviolet Flame Detector: C7035A, C7027A (wiring distance: 200m max., Class 1V 2mm ² 600 Vac vinyl chloride insulated cable)				
Flame Relay	Standard model	Model No.	Rated Power	Power Consumption	Flame Response	Flame Detector Used
		FRS100B100	100Vac 50/60Hz			
		FRS100B200	200Vac 50/60Hz			
		FRS100B104	100Vac 50/60Hz			
	Standard model	Model No.	Rated Power	Power Consumption	Flame Response	Flame Detector Used
		FRS100B204	200Vac 50/60Hz			
		FRS100C100	100Vac 50/60Hz			
		FRS100C200	200Vac 50/60Hz			
	High sensitivity model	Model No.	Rated Power	Power Consumption	Flame Response	Flame Detector Used
		FRS100C104	100Vac 50/60Hz			
		FRS100C204	200Vac 50/60Hz			
		FRS100C150	100Vac 50/60Hz			
High sensitivity model	Model No.	Rated Power	Power Consumption	Flame Response	Flame Detector Used	
	FRS100C250	200Vac 50/60Hz				
High sensitivity model	Model No.	Rated Power	Power Consumption	Flame Response	Flame Detector Used	
	FRS100C154	100Vac 50/60Hz				
High sensitivity model	Model No.	Rated Power	Power Consumption	Flame Response	Flame Detector Used	
	FRS100C254	200Vac 50/60Hz				
Contact Rating	250VA (terminals ③ - ④, ③ - ⑧)					
Flame Sensitivity	Ignition detection level: Flame voltage 1V max. Flame-out detection level: FRS100B Series (flame voltage 0.2V min.) FRS100C Series (flame voltage 0.4V min.)					
Flame Signal Output	0 to 5Vdc, wiring distance 5m max. (use a shielded cable), output terminals: A(-) and B(+) on body. Input impedance of externally connected equipment: 100KΩ min.					
Ambient Temperature	-20 to +60 °C (Only 1 unit mounted), -20 to +45 °C (Gang-mounted over 2 units)					
Ambient Humidity	90%RH, 40 °C (no condensation allowed)					
Vibration Resistance	4.9m/s ² max., 10 to 60Hz for 2 hours each in X, Y and directions (when screw mounted)					
Insulation Resistance	50MΩ min. between each terminal and ground terminal by 500Vdc megger					
Dielectric Strength	1500Vac for 1 min between each terminal and ground terminal, or no failure after applying 1800Vac for 1 sec (excluding flame detector input terminals ⑤ and ⑥)					
Induction Lightning Surge	10kV, 1.2 × 50 μs (JEC-187, surge impedance 75Ω min.) when surge absorber listed below is mounted between terminal ② and ground: • Recommended surge absorber: Specification Sheet No. 10013 (Part No. 83968019-001)					
Life	100,000 operations (at room temperature/humidity and rated voltage)					
Body Color	Gray					
Mounting	Mounted on DIN rail or screw mounted					
Weight	FRS100B,C: approx. 270g, mounting subbase FRS50A: approx. 70g					
Accessories (Order separately)	FRS50A100	Mounting subbase				
	FRS60A	Flame meter				
	123514B	Flame simulator for C7035A/C7027A				
	123514A, 121708	Flame simulator for flame rod, C7012A, C				
	83968019-001	Lighting surge absorber				

This flame relay is equipped with extremely important functions for ensuring flame safeguard. When planning the flame safeguard control systems, please consult a Yamatake sales representative for the explanation of detail specifications.

■ Burner Flame Monitoring

Terminal Connections

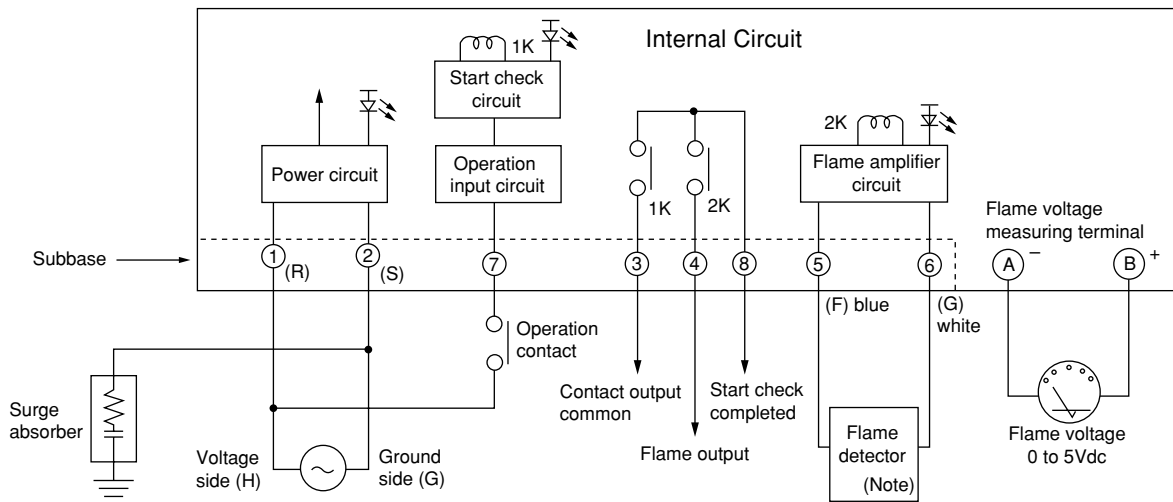

Note) • Flame rod • Minipeeper ultraviolet flame detector

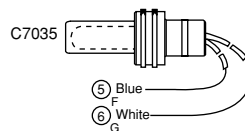
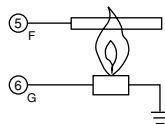

Operation Chart

• Normal Operation

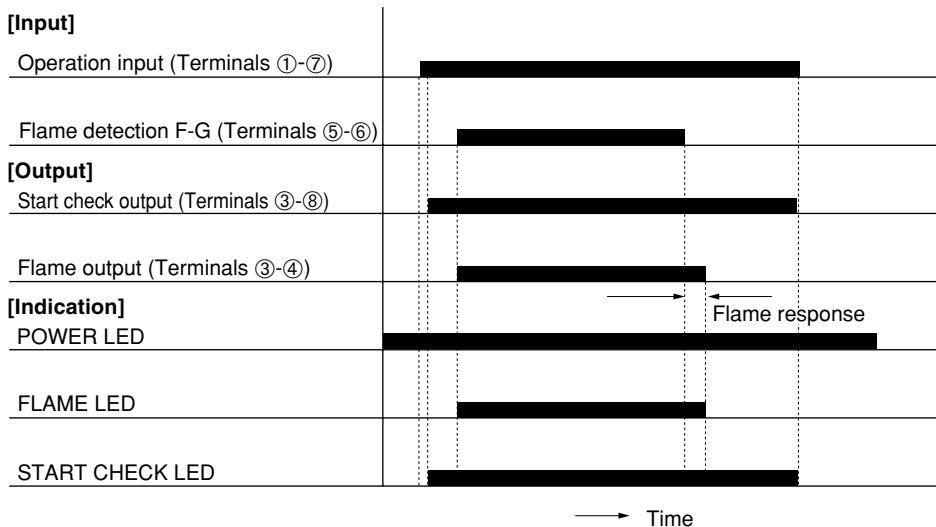

• False Flame Operation

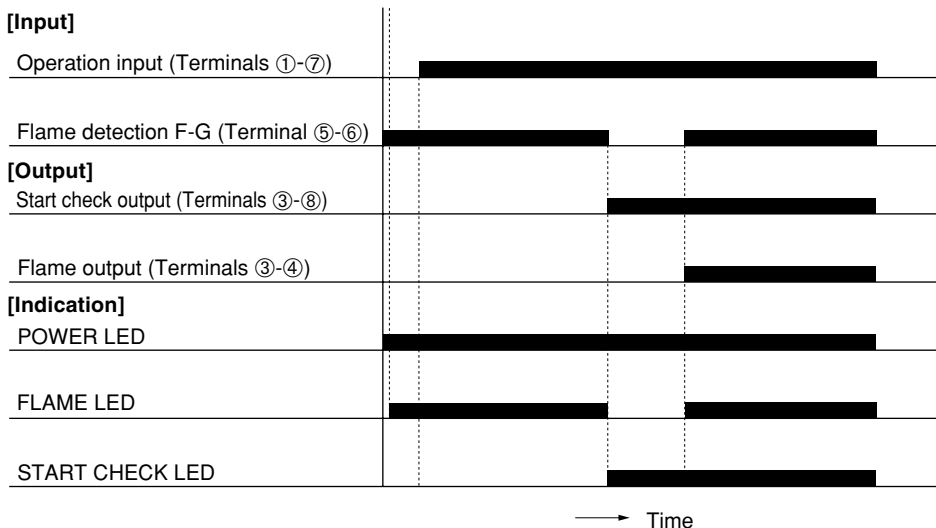

Manual Ignition (Intermittent Pilot)

Terminal Connections

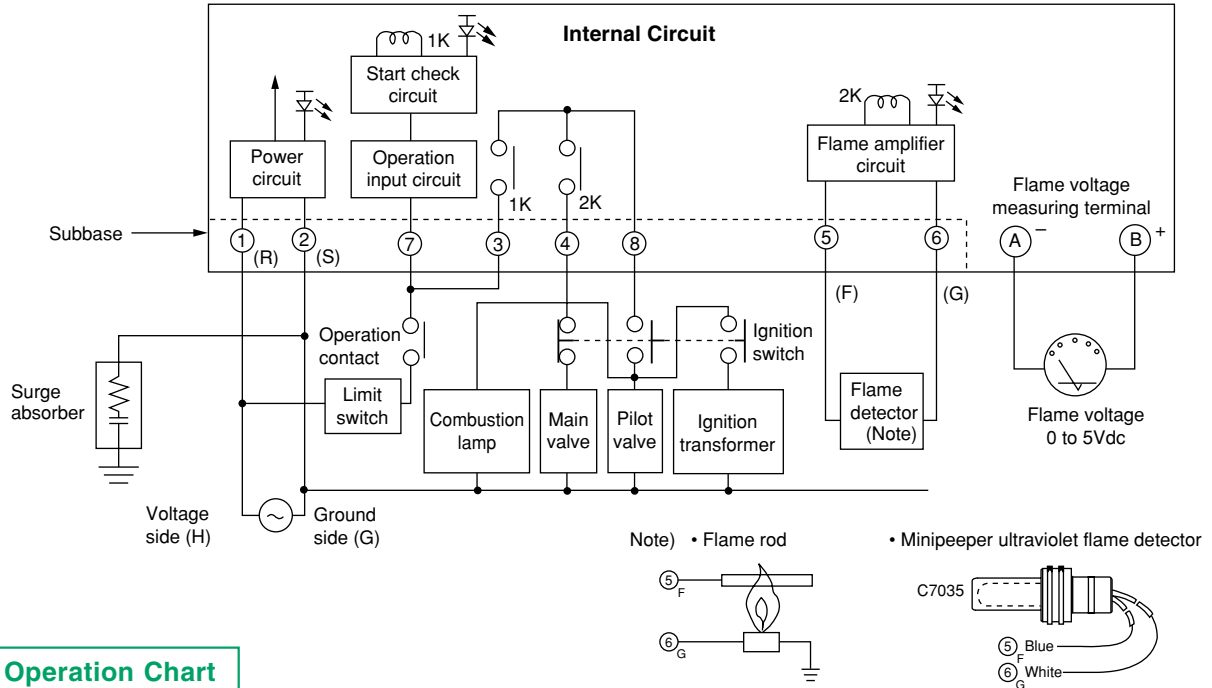

Operation Chart

• Normal Operation

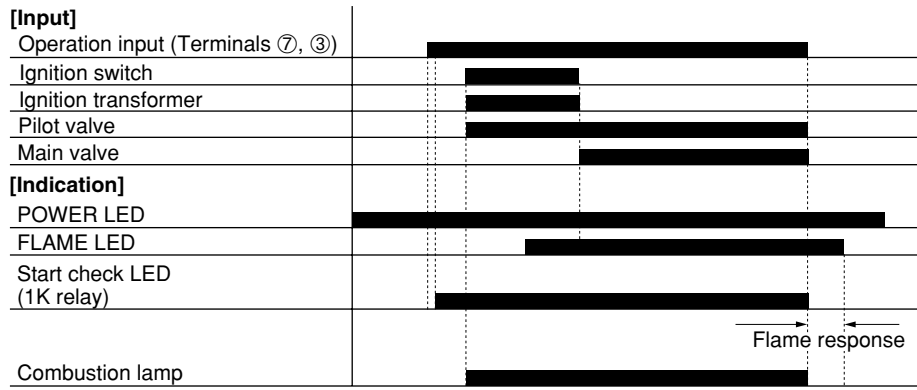

• False Flame Operation

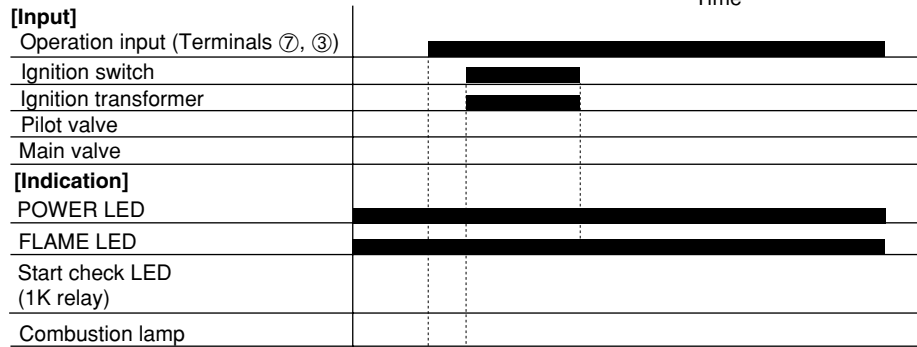

• Flame Failure Operation

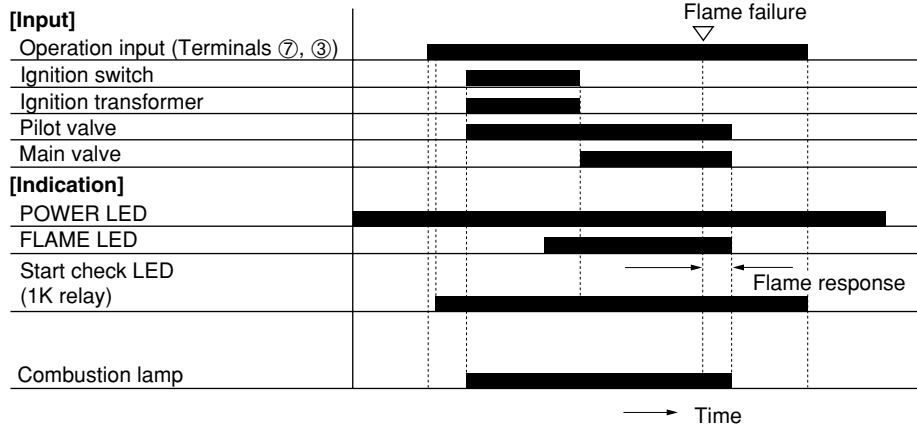

External Dimensions

(Unit: mm)

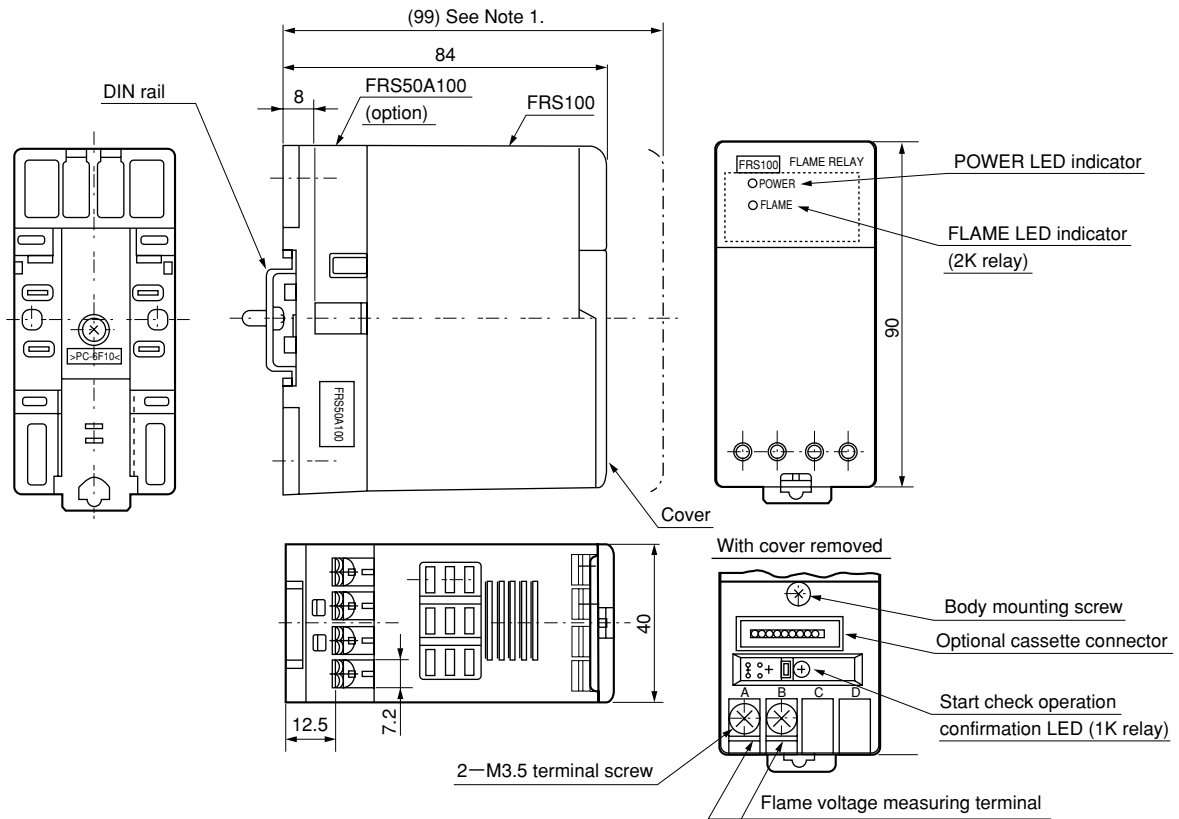

Mounting Subbase (separate order)

Model No.: FRS50A100

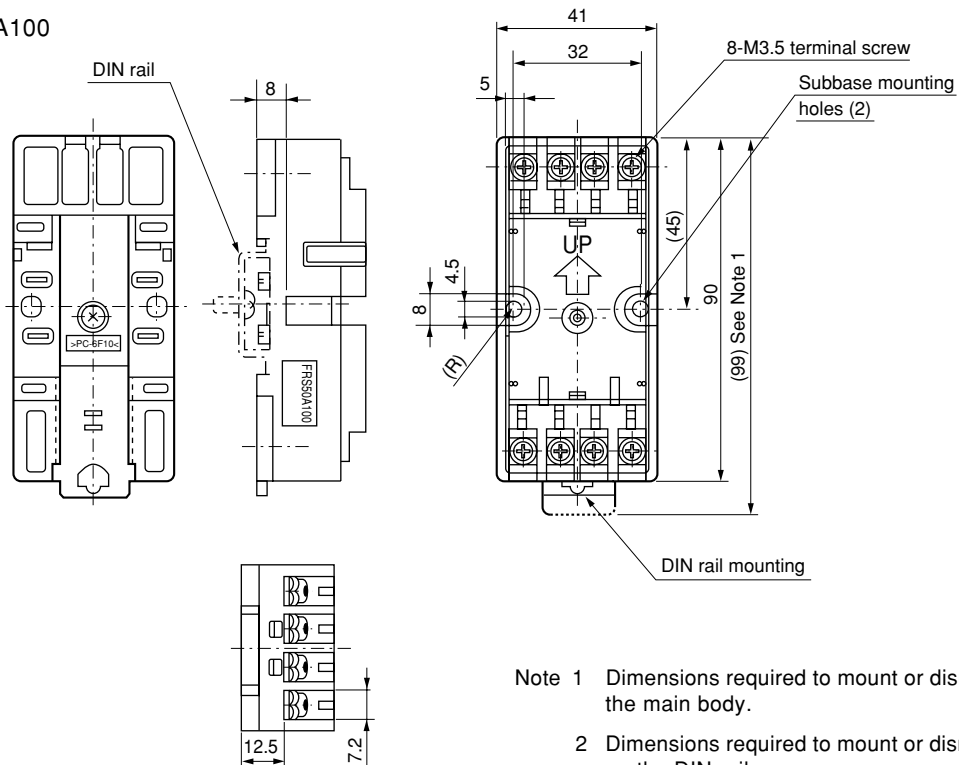

Note 1 Dimensions required to mount or dismount the main body.

2 Dimensions required to mount or dismount on the DIN rail.

3 The above external drawing shows the FRS100 flame relay mounted on the FRS50A100 subbase.

Troubleshooting

Troubleshooting can be performed in combination with the following LED lighting indications:

○ LED OFF
● LED ON

	POWER LED	1K LED (Start check)	FLAME LED	Results	Check Items
Before Start-up	○	○	○	Power is not ON.	Check panel power switch and wiring
After Start-up	●	●	●	Flame is being detected. (normal operation)	—
	●	●	○	Flame is not detected.	Check flame detector, burner, valve, ignition transformer and flame relay
	●	○	●	False flame	Check burner flame, flame sensor and flame relay
	●	○	○	1K relay is not ON.	Check power supply at start-up input terminal ⑦ and flame relay



CAUTION

- (1) Before wiring, be sure to turn the power OFF. Touching terminals by mistake with the power ON might cause an electric shock or malfunction.
- (2) After wiring, be sure to check the wiring connections. Incorrect wiring may cause damage or malfunction.
- (3) Make sure that ignition transformer high-voltage cables are properly connected in order to prevent faulty contacts. Faulty contacts may cause high-frequency noise, resulting in malfunction.
- (4) Do not bundle the power leads and ignition transformer high-voltage cables together with the flame detector lead wires, nor place them in the same conduit. In particular, keep ignition transformer high-voltage cables at least 10cm away from the flame relay and wire separately.
- (5) Do not mount the flame relay at the following locations:
 - Locations near special chemicals or surrounding atmospheres (ammonia, sulfur, chlorine, ethylene compounds, acid, etc.)
 - Locations subject to water spray
 - Locations subject to high temperatures
 - Locations subject to continuous vibration
- (6) Wire external leads between the power supply terminals (100V or 200V and 0V) of the flame relay so that power is applied at all times from the moment when the power switch is turned ON. This wiring is necessary to ensure operation of the self-start checking circuit at start-up.
- (7) Connect the blue signal-lead of the C7035A (or C7027C) to terminal ⑤ and the white signal-lead to terminal ⑥. If the power is turned ON with the flame detector wired incorrectly, it may cause damage to the UV tube.
- (8) Do not transport the flame relay mounted on the DIN rail. Before transporting, remove it from the subbase and pack in a dedicated packing case.
If the flame relay is transported when mounted on the DIN rail, it may detach and become damaged.
- (9) The flame relay is not provided with pre-purge timer and sequence functions necessary for burner ignition. Therefore, take the timer and sequence functions into consideration when designing your control system.
- (10) Do not connect the solenoid valve to the voltage side. When a ground fault occurs, ground current flows to the solenoid valve to open the valve and cause the fuel to flow, regardless of the flame relay operation.
- (11) In the case of the high sensitivity models, flame voltage should be less than 4.5V.

 **RESTRICTIONS ON USE**

This product has been designed, developed and manufactured for general-purpose application in machinery and equipment. Accordingly, when used in the applications outlined below, special care should be taken to implement a fail-safe and/or redundant design concept as well as a periodic maintenance program.

- **Safety devices for plant worker protection**
- **Start/stop control devices for transportation and material handling machines**
- **Aeronautical/aerospace machines**
- **Control devices for nuclear reactors**

Never use this product in applications where human safety may be put at risk.

Specifications are subject to change without notice.

YAMATAKE

Yamatake Corporation
Advanced Automation Company
International Business Headquarters

Totate International Building
2-12-19 Shibuya Shibuya-ku
Tokyo 150-8316 Japan
URL:<http://www.yamatake.com>

This has been printed on recycled paper.

Printed in Japan. (H)
1st Edition: Issued in Oct., 1996
6th Edition: Issued in Apr., 2003