

## International Business Headquarters

*NO. BLTN-03-17-C*

(Domestic No. 02-A-0111)

**Date:** July 24, 2003  
**To:** Those listed  
**Issued by:** CC Chang  
**Subject:** R4313 Obsolescence and R4424 Sales Release

**Purpose:** To announce the obsolescence of the R4313 Protectorelay oil burner control in September 2003, and the sales release of the R4424 as a replacement model.

**Summary:** The R4313 Series featuring the use of safety switch, bimetal heater and timer has been used for more than 30 years for oil hot water boilers. But since there is now a difficulty in continuing the manufacturing of these components made by mechanical parts and the recent sales volume is low, we decided to obsolete this model.

As a standard replacement model of the R4313, the R4424 is now released for sale. The R4424 equips a custom flame safeguard LSI developed by Yamatake.

### Required actions:

- (1) Announce the obsolescence of the R4313 to the burner/boiler manufacturer using the R4313, ask them to place their final order, and recommend them to replace with the R4424 by the obsolescence date.
- (2) Select a replacement model from the attached "Protectorelay Replacement Guide of the R4313 with R4424".
- (3) If a suitable replacement model cannot be found from the guide, ask the end user to contact the burner/boiler manufacturer.

### Obsolescence date of the R4313 Series

- Final date of order: September 30, 2003 to accept the order by factory
- Final date of production: December 20, 2003

### Release date of the R4424 Series

- Immediately

### Notes for replacing the R4313 with the R4424

- (1) The subbase of the R4313 is compatible with the R4424. Since these terminal layouts are common, the R4313 can be replaced with the R4424 by only changing the main body on the subbase.  
In this case, be sure that the R4313 is used in typical wiring described in the Users Manual of the R4313.
- (2) Check the subbase when only the main body is replaced. When the subbase is extremely rusted or dirty, replace the subbase also.
- (3) Upper and under the R4424 body, there are protrusions of 9mm for cover retaining screws. To plug the body on the subbase, 17mm clearances are required upper and under the body.  
The external dimension of R4424 is same as the R4750 Protectorelay for gas-fired burners.

### Outline of the R4424

The R4424 Series is a Protectorelay oil burner control with flame safeguard control circuit using custom LSI, with Lo-Hi solenoid valve output and with a flame and alarm status indicator LED. The R4424 is generally used with C554A, CN120 or CN700 cadmium-sulfide cell flame detector.

### Features

- (1) The prepurge sequence type can be selected from the prepurge model and the preignition prepurge model.
- (2) When a false flame signal is generated during prepurging and it continues, the R4424 is locked out and the FLAME/ALARM LED flashes. The R4313A/B/C just suspends the sequence instead of gives an alarm. An operator of the R4313 does not notice the false flame signal immediately.  
When a false flame signal stops within the prepurge/preignition prepurge timing, the R4424 continues to advance toward the normal sequence.
- (3) When the R4424 detects the flame signal, the FLAME/ALARM indicator LED lights. When the R4424 is locked out, the FLAME/ALARM LED flashes.  
The R4313 has no indicators.
- (4) The allowable ambient temperature is  $-20^{\circ}\text{C}$  to  $+55^{\circ}\text{C}$  at the R4313, while  $-20^{\circ}\text{C}$  to  $+60^{\circ}\text{C}$  at the R4424.

## Appearance

The R4424 has the same externals as the R4750 Protectorelay for gas-fired burners.

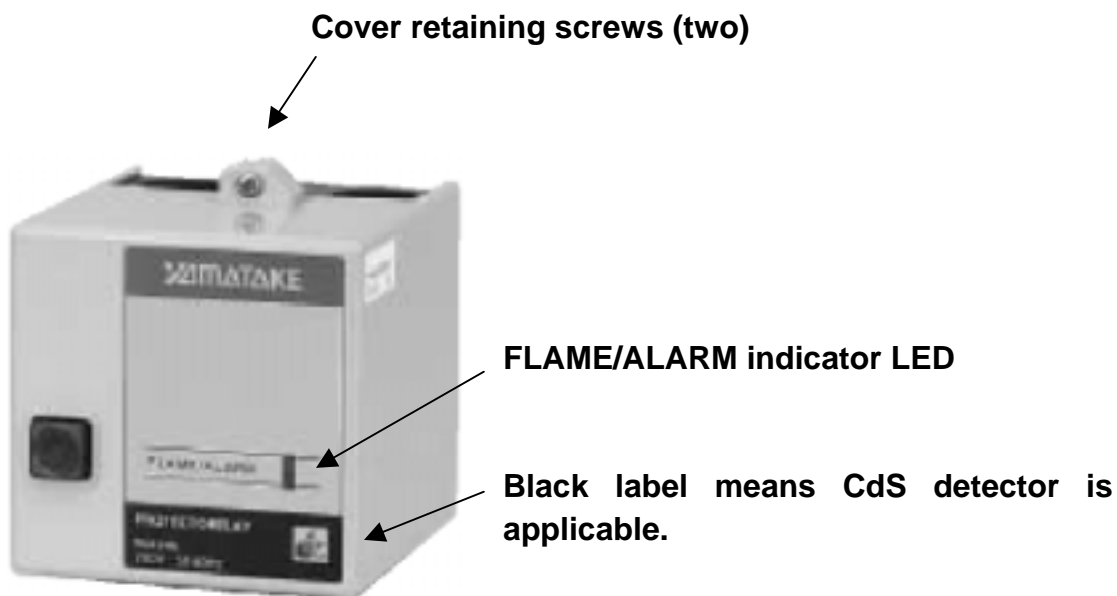

## Selection guide:

Model No.	Power supply voltage	Sequence at flame failure	Sequence timing					Flame detector	Weight
			Prepurge	Preignition prepurge	Ignition trial	Postignition	Flame response		
R4424C104-1	100Vac	Recycle	20+4,-5s	-	7±2s	8±3.5s	Max. 0.8s	C554A	0.68kg
R4424C204-1	200Vac	Recycle	20+4,-5s	-	7±2s	8±3.5s	Max. 0.8s	C554A	0.68kg
R4424D1001-1	100Vac	Non-recycle	-	20±6s	4±1s	11±4s	1.5±0.5s	C554A	0.68kg
R4424D1019-1	200Vac	Non-recycle	-	20±6s	4±1s	11±4s	1.5±0.5s	C554A	0.68kg
R4424D121-1	100Vac	Recycle	-	20±6s	5±1.5s	15±5s	Max. 0.8s	C554A	0.68kg
R4424D221-1	200Vac	Recycle	-	20±6s	5±1.5s	15±5s	Max. 0.8s	C554A	0.68kg
R4424E104-1	100Vac	Non-recycle	20+4,-5s	-	5±1.5s	6.5±2.5s	1.5±0.5s	C554A	0.68kg
R4424E204-1	200Vac	Non-recycle	20+4,-5s	-	5±1.5s	6.5±2.5s	1.5±0.5s	C554A	0.68kg

## **Protectorelay Replacement Guide of the R4313 with R4424**

### **1. Obsolescence of the R4313A/B/C/D/E Protectorelay**

The R4313A/B/C/D/E Protectorelay will be obsoleted at the end of September 2003 because its manufacturing is difficult to continue.

The R4313 can be replaced with the R4424. For replacement, refer this replacement guide.

## **2. Replacement Guide of the R4313 with R4424**

Replace the R4313 not by rote but with care, though the subbase and terminal layout are compatible with the R4424.

\* Attention: This document assumes that the R4313 is used in typical wiring described in our users manual. It may be different from the schematic diagram which burner/boiler manufacturer provides.

### **2.1 Outline/table of replacement models**

R4313B	→	R4424D121-1, 221-1
R4313C	→	R4424C104-1, 204-1
R4313D	→	R4424D1001-1, 1019-1
R4313E	→	R4424E104-1, 204-1

\* Refer to next page for details.

### 2.1.1 Outline of replacement models

	Preignition prepurge model		Prepurge model	
Recycle model	R4313B	→ R4424D (Recycle model) <sup>(Note 1)</sup>	R4313C	→ R4424C <sup>(Note 1)</sup>
Non-recycle model	R4313D <sup>(Note 1)</sup>	→ R4424D (Non-recycle model) <sup>(Note 1)</sup>	R4313E <sup>(Note 1)</sup>	→ R4424E <sup>(Note 1)</sup>

Note 1: R4313D/E: Lo-Hi model, R4424C/D/E: Lo-Hi model

\* The R4424 Series is the Protectorelay, which uses custom flame safeguard LSI. When the R4424 detects the flame signal, the red LED lights. When the R4424 is locked out, the red LED flashes.

### 2.1.2 Table of replacement models

Obsoleted model No. in 2003	Replacement model No.	Power supply voltage	Sequence at flame failure	Sequence timing (under normal temperature, normal humidity, and rated voltage)					
				Prepurge	Preignition prepurge	Ignition trial	Postignition	Lockout	Flame response
<b>R4313B</b>	<b>R4424D121-1</b>	100Vac	Recycle	-	20±6s	5±1.5s	15±5s	Max. 23s	Max. 0.8s
	<b>R4424D221-1</b>	200Vac							
<b>R4313C</b>	<b>R4424C104-1</b>	100Vac	Recycle	20+4,-5s	-	7±2s	8±3.5s	Max. 23s	Max. 0.8s
	<b>R4424C204-1</b>	200Vac							
<b>R4313D</b> <sup>(Note 2)</sup>	<b>R4424D1001-1</b>	100Vac	Non-recycle	-	20±6s	4±1s	11±4s	Max. 23s	1.5±0.5s
	<b>R4424D1019-1</b>	200Vac							
<b>R4313E</b> <sup>(Note 2)</sup>	<b>R4424E104-1</b>	100Vac	Non-recycle	20+4,-5s	-	5±1.5s	6.5±2.5s	Max. 23s	1.5±0.5s
	<b>R4424E204-1</b>	200Vac							
<b>R4313A</b>	There are no replacement models (Consider to use C, D and E type models above.).								

Note 2: The replacement models are different in the following R4313D/R4313E models:

<b>R4313D500</b>	<b>R4424D500-1</b>	200Vac	Non-recycle	-	20±6s	2.3±0.7s	7±2.5s	Max. 23s	2±1s
<b>R4313E500</b>	<b>R4424E500-1</b>	200Vac	Non-recycle	35±10s	-	5±1.5s	15±5s	Max. 23s	2±1s

## 2.2 Specifications of R4313B/C/D/E models

### 2.2.1 Specifications of R4313B

Replacement model No.	Power supply voltage	Sequence at flame failure	Sequence timing (normal temperature, humidity and rated powered supply voltage)						Notes
			Prepurge	Preignition prepurge	Ignition trial	Postignition	Lockout	Flame response	
R4424D121-1	100Vac	Recycle	-	20 ± 6s	5 ± 1.5s	15 ± 5s	Max. 23s	Max. 0.8s	CdS: C554A
R4424D221-1	200Vac								

 : OEM products, which have not been sold directly to end users for replacement

Replacement with R4424D <sup>(Note 1)</sup>	Main model No. of R4313B	Power supply voltage	Sequence at flame failure	Sequence timing (normal temperature, humidity and rated powered supply voltage)						Notes
				Prepurge	Preignition prepurge	Ignition trial <sup>(Note 2)</sup>	Postignition	Lockout	Flame response	
Possible	R4313B1009 R4313B1017	100Vac 200Vac	Recycle	-	15 to 25s	10 to 20s	20 to 80s	10 to 20s	Max. 0.8s	CdS: C554A (Standard model)
Impossible <sup>(Note 3)</sup>	R4313B1009-4 R4313B1017-4	100Vac 200Vac	Recycle	-	15 to 25s	10 to 20s	20 to 80s	10 to 20s	Max. 0.8s	CdS: C554A (OEM model)
Possible	R4313B1009X10 R4313B1017X10	100Vac 200Vac	Recycle	-	15 to 25s	10 to 20s	20 to 80s	10 to 20s	Max. 0.8s	CdS: C554A For trade line (without subbase)
Conditionally possible <sup>(Note 4)</sup>	R4313B01S1 R4313B02S1	100Vac 200Vac	Recycle	-	5 to 15s	10 to 20s	15 to 120s	10 to 20s	Max. 0.8s	CdS: C554A (Standard model)
Impossible <sup>(Note 3)</sup>	R4313B1025 * R4313B1033 *	100Vac 200Vac	Recycle	-	15 to 25s	10 to 20s	20 to 80s	10 to 20s	Max. 0.8s	CdS: C562A (OEM model ?)
Impossible <sup>(Note 3)</sup>	R4313B01J1 * R4313B02J1	100Vac 200Vac	Recycle	-	15 to 25s	10 to 20s	20 to 80s	10 to 20s	Max. 0.8s	CdS: C562A (OEM model)
Impossible <sup>(Note 3)</sup>	R4313B01J1X10 R4313B02J1X10	100Vac 200Vac	Recycle	-	15 to 25s	10 to 20s	20 to 80s	10 to 20s	Max. 0.8s	CdS: C562A For trade line (without subbase)
Impossible <sup>(Note 3)</sup>	R4313B03J1 * R4313B04J1 *	100Vac 200Vac	Recycle	-	15 to 25s	10 to 20s	20 to 80s	10 to 20s	Max. 0.8s	CdS: C562A (OEM model ?)
Impossible <sup>(Note 3)</sup>	R4313B05J1 R4313B06J1	100Vac 200Vac	Recycle	-	15 to 25s	10 to 20s	20 to 80s	10 to 20s	Max. 0.8s	CdS: C562A (OEM model)

\*: Already obsoleted

Note 1: Possibility of replacement is determined by the power supply voltage, sequence at flame failure, sequence timing, flame response and applicable CdS flame detector. It is determined to be possible to replace when the replacement model has an approximate sequence timing. When replacing the R4313, be sure to carry out matching test of burner and boiler.

Note 2: The ignition trial timing of the R4313 is common with the lockout timing.

Note 3: The CdS C562A has to be replaced with the C554A, because the C562A is not applicable to the R4424. Check and confirm that the C554A can be mounted because its externals and mounting dimensions are different from the C562A. When it is not clear, recommend the user to contact the burner/boiler manufacturer.

Note 4: Though there are no safety risks, it takes more time to start because the preignition prepurge timing becomes 20 seconds longer.

## 2.2.2 Specifications of R4313C

Replacement model No.	Power supply voltage	Sequence at flame failure	Sequence timing (normal temperature, humidity and rated powered supply voltage)						Notes
			Prepurge	Preignition prepurge	Ignition trial	Postignition	Lockout	Flame response	
R4424C104-1	100Vac	Recycle	20+4, -5s	-	7±2s	8±3.5s	Max. 23s	Max. 0.8s	CdS: C554A
R4424C204-1	200Vac								

□ : OEM products, which have not been sold directly to end users for replacement

Replacement with R4424C <sup>(Note 1)</sup>	Main model No. of R4313C	Power supply voltage	Sequence at flame failure	Sequence timing (normal temperature, humidity and rated powered supply voltage)						Notes
				Prepurge	Preignition prepurge	Ignition trial <sup>(Note 2)</sup>	Postignition	Lockout	Flame response	
Possible	R4313C1007* R4313C1015*	100Vac 200Vac	Recycle	15 to 25s	-	10 to 20s	20 to 80s	10 to 20s	Max. 0.8s	CdS: C554A (Standard model)
Possible	R4313C1007-1* R4313C1015-1*	100Vac 200Vac	Recycle	15 to 25s	-	10 to 20s	20 to 80s	10 to 20s	Max. 0.8s	CdS: C554A (Standard model)
Possible	R4313C1007-5 R4313C1015-5	100Vac 200Vac	Recycle	15 to 25s	-	10 to 20s	20 to 80s	10 to 20s	Max. 0.8s	CdS: C554A (Standard model)
Impossible <sup>(Note 3)</sup>	R4313C1007-5X R4313C1015-5X	100Vac 200Vac	Recycle	15 to 25s	-	10 to 20s	20 to 80s	10 to 20s	Max. 0.8s	CdS: C554A (OEM model)
Impossible <sup>(Note 3)</sup>	R4313C1007-5S* R4313C1015-5S*	100Vac 200Vac	Recycle	15 to 25s	-	10 to 20s	20 to 80s	10 to 20s	Max. 0.8s	CdS: C554A (OEM model)
Impossible <sup>(Note 4)</sup>	R4313C1023* R4313C1031*	100Vac 200Vac	Recycle	15 to 25s	-	10 to 20s	20 to 80s	10 to 20s	Max. 0.8s	CdS: C562A (OEM model ?)
Possible	R4313C03J1* R4313C04J1*	100Vac 200Vac	Recycle	15 to 25s	-	10 to 20s	20 to 80s	10 to 20s	Max. 0.8s	CdS: C554A (OEM model ?)
Conditionally possible <sup>(Note 5)</sup>	R4313C05J1 R4313C06J1	100Vac 200Vac	Recycle	25 to 40s	-	10 to 20s	15 to 80s	10 to 20s	Max. 0.8s	CdS: C554A (OEM model ?)

\*: Already obsoleted

Note 1: Possibility of replacement is determined by the power supply voltage, sequence at flame failure, sequence timing, flame response and applicable CdS flame detector. It is determined to be possible to replace when the replacement model has an approximate sequence timing. When replacing the R4313, be sure to carry out matching test of burner and boiler.

Note 2: The ignition trial timing of the R4313 is common with the lockout timing.

Note 3: There are no replacement models because it has special specifications beside this table.

Note 4: The CdS C562A has to be replaced with the C554A, because the C562A is not applicable to the R4424. Check and confirm that the C554A can be mounted because its externals and mounting dimensions are different from the C562A. When it is not clear, recommend the user to contact the burner/boiler manufacturer.

Note 5: There is a safety risk that the preignition prepurge timing shorten to 20 seconds. Recommend the user to contact the burner/boiler manufacturer.

## 2.2.3 Specifications of R4313D

Replacement model No.	Power supply voltage	Sequence at flame failure	Sequence timing (normal temperature, humidity and rated powered supply voltage)						Notes
			Prepurge	Preignition prepurge	Ignition trial	Postignition	Lockout	Flame response	
R4424D1001-1	100Vac	Non-recycle	-	20 ± 6s	4 ± 1s	11 ± 4s	Max. 23s	1.5 ± 0.5s	CdS: C554A
R4424D1019-1	200Vac								

 : OEM products, which have not been sold directly to end users for replacement

Replacement with R4424D (Note 1)	Main model No. of R4313D	Power supply voltage	Sequence at flame failure	Sequence timing (normal temperature, humidity and rated powered supply voltage)						Notes
				Prepurge	Preignition prepurge	Ignition trial	Postignition	Lockout	Flame response	
Possible	R4313D1005 *	100Vac								CdS: C554A (OEM model)
Possible	R4313D1013	200Vac	Non-recycle	-	15 to 25s	4 to 6.2s	3 to 20s	10 to 20s	0.8 to 3s	CdS: C554A (Standard model)
Impossible (Note 2)	R4313D150 *	100Vac								CdS: C572A (OEM model)
Conditionally possible (Note 3)	R4313D1021 * R4313D1039 *-----	100Vac 200Vac	Non-recycle	-	15 to 25s	4 to 6.2s	3 to 20s	10 to 20s	Max. 0.8s	CdS: C554A
Impossible (Note 2)	R4313C108 * R4313C208 *-----	100Vac 200Vac	Non-recycle	-	25 to 45s	2 to 5s	3 to 20s	10 to 20s	0.8 to 3s	CdS: C562A
Impossible (Note 4)	R4313D113 *	200Vac	Non-recycle	-	15 to 25s	1.5 to 3.5s	3 to 20s	10 to 20s	0.8 to 3s	CdS: C554A (OEM model)
Impossible (Note 3,4)	R4313D139 *	200Vac	Non-recycle	-	15 to 25s	1.5 to 3.5s	3 to 20s	10 to 20s	Max. 0.8s	CdS: C554A (OEM model)
Impossible	R4313D500 (Note 5)	200Vac	Non-recycle	-	15 to 25s	2.5 to 4.5s	3 to 20s	10 to 20s	0.8 to 3s	CdS: C554A (Standard model)
Impossible (Note 6)	R4313D504	200Vac	Non-recycle	-	90 to 150s	6 to 14s	3 to 20s	10 to 20s	0.8 to 3s	CdS: C554A (OEM model)

\*: Already obsoleted

Note 1: Possibility of replacement is determined by the power supply voltage, sequence at flame failure, sequence timing, flame response and applicable CdS flame detector. It is determined to be possible to replace when the replacement model has an approximate sequence timing. When replacing the R4313, be sure to carry out matching test of burner and boiler.

Note 2: This model cannot be replaced with R4424 because applicable CdS is different in type and mounting dimensions. When this model is replaced, confirm the name of end user and burner/boiler manufacturer, and consult them showing the specification difference.

Note 3: There is a safety risk because the flame response becomes long. Contact the burner/boiler manufacturer.

Note 4: There is a safety risk because the ignition trial becomes long. Contact the burner/boiler manufacturer.

Note 5: The R4313D500 is replaced with the R4424D500-1.

Replacement model No.	Power supply voltage	Sequence at flame failure	Sequence timing (normal temperature, humidity and rated powered supply voltage)						Notes
			Prepurge	Preignition prepurge	Ignition trial	Postignition	Lockout	Flame response	
R4424D500-1	200Vac	Non-recycle	-	20 ± 6s	2.3 ± 0.7s	7 ± 2.5s	Max. 23s	2 ± 1s	CdS: C554A (Standard model)

Note 6: There is a safety risk that the preignition prepurge timing shortens. Recommend the user to contact the burner/boiler manufacturer.

## 2.2.4 Specifications of R4313E

Replacement model No.	Power supply voltage	Sequence at flame failure	Sequence timing (normal temperature, humidity and rated powered supply voltage)						Notes
			Prepurge	Preignition prepurge	Ignition trial	Postignition	Lockout	Flame response	
<b>R4424E104-1</b>	<b>100Vac</b>	<b>Non-recycle</b>	<b>20+4,-5s</b>	<b>-</b>	<b>5 ± 1.5s</b>	<b>6.5 ± 2.5s</b>	<b>Max. 23s</b>	<b>1.5 ± 0.5s</b>	<b>CdS: C554A</b>
<b>R4424E204-1</b>	<b>200Vac</b>								

Replacement with R4424E <sup>(Note 1)</sup>	Main model No. of R4313E	Power supply voltage	Sequence at flame failure	Sequence timing (normal temperature, humidity and rated powered supply voltage)						Notes
				Prepurge	Preignition prepurge	Ignition trial	Postignition	Lockout	Flame response	
<b>Possible</b>	<b>R4313E1002 *</b> <b>R4313E1010</b>	<b>100Vac</b> <b>200Vac</b>	<b>Non-recycle</b>	<b>15 to 25s</b>	<b>-</b>	<b>4 to 6.2s</b>	<b>3 to 20s</b>	<b>10 to 20s</b>	<b>0.8 to 3s</b>	<b>CdS: C554A (Standard model)</b>
<b>Impossible</b> <sup>(Note 2)</sup>	<b>R4313E1028 *</b> <b>R4313E1036 *</b>	<b>100Vac</b> <b>200Vac</b>	<b>Recycle</b>	<b>15 to 25s</b>	<b>-</b>	<b>4 to 6.2s</b>	<b>3 to 20s</b>	<b>10 to 20s</b>	<b>0.8 to 3s</b>	<b>CdS: C554A</b>
<b>Impossible</b> <sup>(Note 3)</sup>	<b>R4313E508 *</b>	<b>110Vac</b>	<b>Non-recycle</b>	<b>15 to 25s</b>	<b>-</b>	<b>4 to 6.2s</b>	<b>3 to 20s</b>	<b>10 to 20s</b>	<b>Max. 0.8s</b>	<b>CdS: C554A Tropicalization + 110Vac + label in English</b>
<b>Impossible</b> <sup>(Note 3)</sup>	<b>R4313E512 *</b>	<b>220Vac</b>	<b>Non-recycle</b>	<b>15 to 25s</b>	<b>-</b>	<b>4 to 6.2s</b>	<b>3 to 20s</b>	<b>10 to 20s</b>	<b>0.8 to 3s</b>	<b>CdS: C554A Tropicalization + 220Vac + label in English</b>

\*: Already obsoleted

**Note 1:** Possibility of replacement is determined by the power supply voltage, sequence at flame failure, sequence timing, flame response and applicable CdS flame detector. It is determined to be possible to replace when the replacement model has an approximate sequence timing. When replacing the R4313, be sure to carry out matching test of burner and boiler.

**Note 2:** There are no replacement models because it is recycle sequence model.

**Note 3:** There are no replacement models because they are specific supply voltage and tropicalization models.

Replacement model No.	Power supply voltage	Sequence at flame failure	Sequence timing (normal temperature, humidity and rated powered supply voltage)						Notes
			Prepurge	Preignition prepurge	Ignition trial	Postignition	Lockout	Flame response	
<b>R4424E500-1</b>	<b>200Vac</b>	<b>Non-recycle</b>	<b>35 ± 10s</b>	<b>-</b>	<b>5 ± 1.5s</b>	<b>15 ± 5s</b>	<b>Max. 23s</b>	<b>2 ± 1s</b>	<b>CdS: C554A (Standard model)</b>

Replacement with R4424E <sup>(Note 1)</sup>	Main model No. of R4313E	Power supply voltage	Sequence at flame failure	Sequence timing (normal temperature, humidity and rated powered supply voltage)						Notes
				Prepurge	Preignition prepurge	Ignition trial	Postignition	Lockout	Flame response	
<b>Possible</b>	<b>R4313E500</b>	<b>200Vac</b>	<b>Non-recycle</b>	<b>25 to 45s</b>	<b>-</b>	<b>4 to 6.2s</b>	<b>3 to 20s</b>	<b>10 to 20s</b>	<b>0.8 to 3s</b>	<b>CdS: C554A (Standard model)</b>
<b>Impossible</b> <sup>(Note 4)</sup>	<b>R4313E520 *</b>	<b>200Vac</b>	<b>Non-recycle</b>	<b>25 to 45s</b>	<b>-</b>	<b>4 to 6.2s</b>	<b>3 to 20s</b>	<b>10 to 20s</b>	<b>0.8 to 3s</b>	<b>CdS: C554A Tropicalized model of R4313E500</b>

**Note 4:** The R4424E500-1 is not tropicalized.

## **2.3 Method of changing over wiring from R4313 to R4424**

### **2.3.1 Method of changing over wiring from R4313B to R4424D121-1/221-1**

#### Terminal layouts

R4424D		R4313B		R4424D	
5	Ignition transformer	5	Ignition transformer	2	Power supply (Ground side L2)
4	Lo valve	4	Valve	2	Power supply (Ground side L2)
3	Fan motor	3	Fan motor	2	Power supply (Ground side L2)
A	Alarm	A	Alarm		Unused terminal
A1	Alarm	A1	Alarm	1	Power supply (Voltage side L1)
S	CdS	S	Flame detector	T	Temperature controller
S1	CdS	S	Flame detector	T1	Temperature controller

- (1) Connect the limit controller used with the R4313B in series to the R4424D power supply (Voltage side L1) terminal 1.
- (2) Although the both alarm outputs of the R4313B and R4424D are no-voltage contacts, the supply voltage type must be checked because either AC or DC power supply can be connected.
- (3) The valve terminal 4 of the R4313B corresponds to the Lo valve terminal 4 of the R4424D.
- (4) Check the dirt and rust condition of the subbase. When it is extremely rusted or dirty, replace the subbase also.

#### Reference

- Replace the R4313B according to the schematic diagram which burner/boiler manufacturer provides.
- R4313B User's Manual/Specification CP-SP-1076E (External and mounting dimensions, typical example of external wiring, sequential operation, specification and others.)

#### [WARNING / CAUTION]

- Before wiring, removing or mounting the product, be sure to turn the power OFF.
- Mounting, wiring, inspection and adjustment should be carried out by a specialist who has been trained in how to handle burners and this product.
- Wire the product properly according to predetermined standards. Also wire the product using designated cables according to recognized installation methods. Failure to do so might cause incorrect operation or malfunction.

### 2.3.2 Method of changing over wiring from R4313C to R4424C104-1/204-1

#### Terminal layouts

R4424C	
5	Ignition transformer
4	Lo valve
3	Fan motor
A	Alarm
A1	Alarm
S	CdS
S1	CdS

R4313C	
5	Ignition transformer
4	Valve
3	Fan motor
A	Alarm
A1	Alarm
S	Flame detector
S	Flame detector

2	Power supply (Ground side L2)
2	Power supply (Ground side L2)
2	Power supply (Ground side L2)
	Unused terminal
1	Power supply (Voltage side L1)
T	Temperature controller
T1	Temperature controller

R4424C	
2	Power supply (Ground side L2)
2	Power supply (Ground side L2)
2	Power supply (Ground side L2)
6	Hi valve
1	Power supply (Voltage side L1)
T	Temperature controller
T1	Temperature controller

- (1) Connect the limit controller used with the R4313C in series to the R4424C power supply (Voltage side L1) terminal 1.
- (2) Although the both alarm outputs of the R4313C and R4424C are no-voltage contacts, the supply voltage type must be checked when wiring because either AC or DC power supply can be connected.
- (3) The valve terminal 4 of the R4313C corresponds to the Lo valve terminal 4 of the R4424C.
- (4) Check the dirt and rust condition of the subbase. When it is extremely rusted or dirty, replace the subbase also.

#### Reference

- Replace the R4313C according to the schematic diagram which burner/boiler manufacturer provides.

#### [WARNING / CAUTION]

- Before wiring, removing or mounting the product, be sure to turn the power OFF.
- Mounting, wiring, inspection and adjustment should be carried out by a specialist who has been trained in how to handle burners and this product.
- Wire the product properly according to predetermined standards. Also wire the product using designated cables according to recognized installation methods. Failure to do so might cause incorrect operation or malfunction.

### 2.3.3 Method of changing over wiring from R4313D to R4424D1001-1/1019-1

#### Terminal layouts

R4424D	
5	Ignition transformer
4	Lo valve
3	Fan motor
A	Alarm
A1	Alarm
S	CdS
S1	CdS

R4313D	
5	Ignition transformer
4	Lo valve
3	Electro-magnetic relay for motor
A	Alarm
A1	Alarm
S	Flame detector
S	Flame detector

2	Power supply (Ground side L2)
2	Power supply (Ground side L2)
2	Power supply (Ground side L2)
6	Hi valve
1	Power supply (Voltage side L1)
T	Temperature controller
T1	Temperature controller

R4424D	
2	Power supply (Ground side L2)
2	Power supply (Ground side L2)
2	Power supply (Ground side L2)
6	Hi valve
1	Power supply (Voltage side L1)
T	Temperature controller
T1	Temperature controller

- (1) Connect the limit controller used with the R4313D in series to the R4424D power supply (Voltage side L1) terminal 1.
- (2) Although the both alarm outputs of the R4313D and R4424D are no-voltage contacts, the supply voltage type must be checked when wiring because either AC or DC power supply can be connected.
- (3) Check the dirt and rust condition of the subbase. When it is extremely rusted or dirty, replace the subbase also.

#### Reference

- Replace the R4313D according to the schematic diagram which burner/boiler manufacturer provides.

#### [WARNING / CAUTION]

- Before wiring, removing or mounting the product, be sure to turn the power OFF.
- Mounting, wiring, inspection and adjustment should be carried out by a specialist who has been trained in how to handle burners and this product.
- Wire the product properly according to predetermined standards. Also wire the product using designated cables according to recognized installation methods. Failure to do so might cause incorrect operation or malfunction.

### 2.3.4 Method of changing over wiring from R4313E to R4424E104-1/204-1

#### Terminal layouts

R4424E	
5	Ignition transformer
4	Lo valve
3	Fan motor
A	Alarm
A1	Alarm
S	CdS
S1	CdS

R4313E	
5	Ignition transformer
4	Lo valve
3	Electro-magnetic relay for motor
A	Alarm
A1	Alarm
S	CdS
S	CdS

2	Power supply (Ground side L2)
2	Power supply (Ground side L2)
2	Power supply (Ground side L2)
6	Hi valve
1	Power supply (Voltage side L1)
T	Temperature controller
T1	Temperature controller

R4424E	
2	Power supply (Ground side L2)
2	Power supply (Ground side L2)
2	Power supply (Ground side L2)
6	Hi valve
1	Power supply (Voltage side L1)
T	Temperature controller
T1	Temperature controller

- (1) Connect the limit controller used with the R4313E in series to the R4424E power supply (Voltage side L1) terminal 1.
- (2) Although the both alarm outputs of the R4313E and R4424E are no-voltage contacts, the supply voltage type must be checked when wiring because either AC or DC power supply can be connected.
- (3) Check the dirt and rust condition of the subbase. When it is extremely rusted or dirty, replace the subbase also.

#### Reference

- Replace the R4313E according to the schematic diagram which burner/boiler manufacturer provides.

#### [WARNING / CAUTION]

- Before wiring, removing or mounting the product, be sure to turn the power OFF.
- Mounting, wiring, inspection and adjustment should be carried out by a specialist who has been trained in how to handle burners and this product.
- Wire the product properly according to predetermined standards. Also wire the product using designated cables according to recognized installation methods. Failure to do so might cause incorrect operation or malfunction.

## 2.4 Schematic diagrams of the R4313A/B/C/D/E

### 2.4.1 Schematic diagram of the R4313A

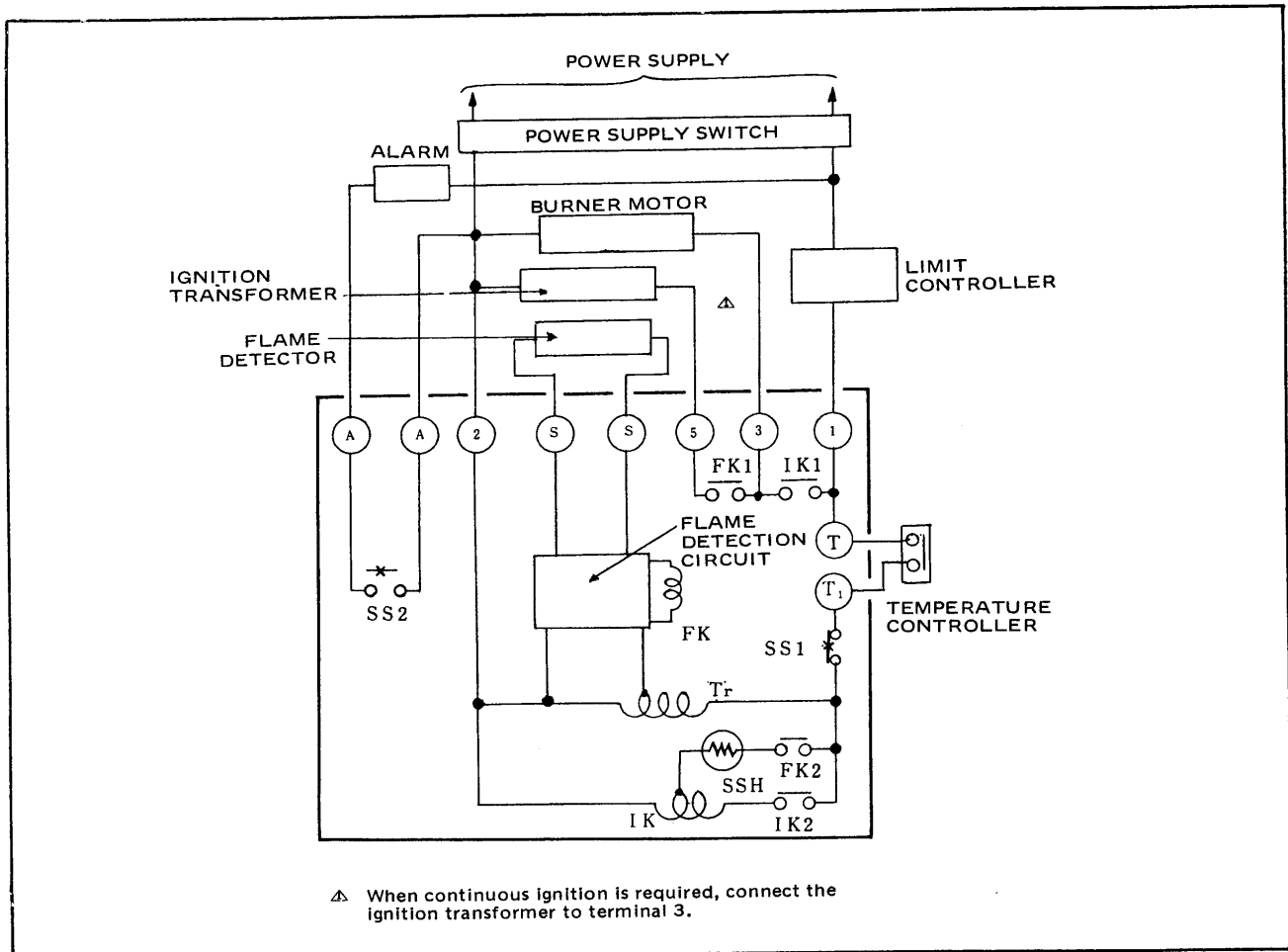

FIG. 6— TYPICAL SCHEMATIC DIAGRAM OF EXTERNAL CIRCUIT

## CHECKOUT

- 1: Flame Failure  
Make the condition of combustion normal by starting the device. Shut off the manual valve of fuel oil supply and stop the combustion. Flame relay is energized at the same time as the flame is out. Then relay 1K is de-energized and operation restarts.
2. Ignition Failure  
Shut off the manual valve of fuel oil supply and stop the supply of fuel oil.  
Then the device starts, keeping the closed position. Since the combustion is not performed, the safety switch operates after the safety switch timing. Then burner motor and ignition transformer are stopped, and alarm circuit is established.

Check the wiring first if some trouble is found in the operational inspection of items 1 and 2. Check to see if flame detector is correctly installed and positioned to sense flame properly.

### IMPORTANT

Do not attempt to trip the safety switch by pulling on the red button.

**SAFETY PROTECTION**

<p>Burner fails to ignite on call for heat.</p>	<p>Safety switch is heated through relay contacts FK3 and opens in approximately 15 seconds. Relay 1K is de-energized, opening contacts 1K1, 1K2 and shutting off the burner motor and ignition. Requires manual resetting of safety switch.</p>
<p>Flame fails during burner on cycle.</p>	<p>When cad cell senses no flame, relay FK is energized. Contacts FK3 close, causing the safety switch heater to begin heating. After 15 seconds, the safety switch opens, de-energizing relay 1K. Contacts 1K1 and 1K2 open, shutting off burner motor, valve and ignition. The safety switch must be manually reset to restart the burner. If the flame is re-established within the safety switch heating period, operation returns to normal.</p>
<p>Power failure during call for heat.</p>	<p>Burner shuts down safety and automatically returns to normal operation when power is restored.</p>

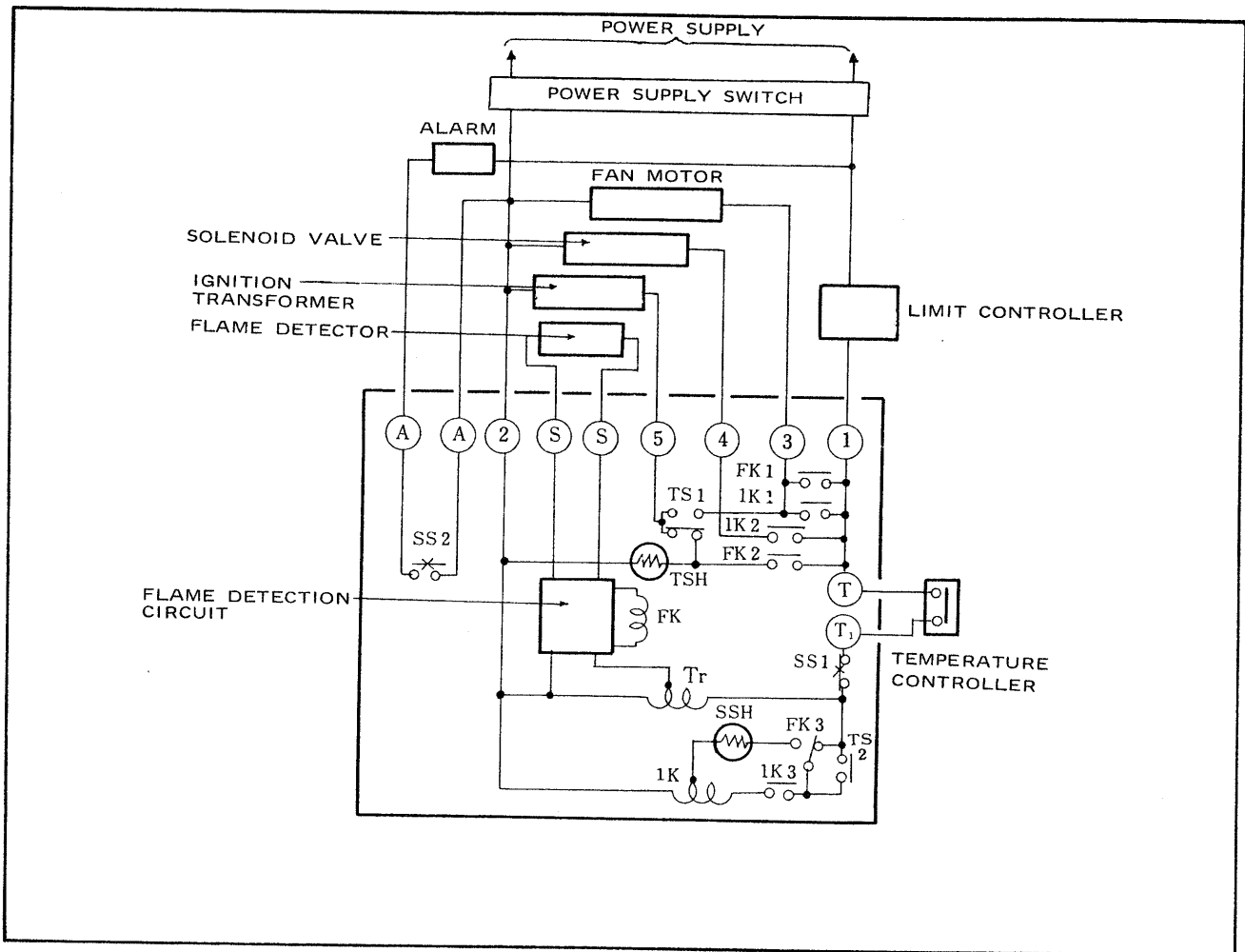
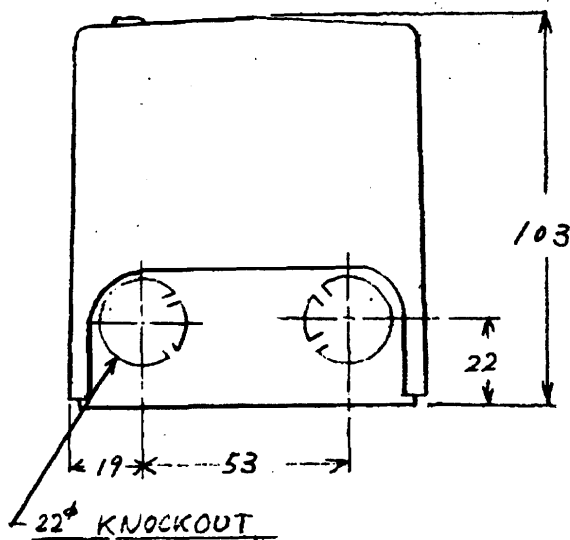
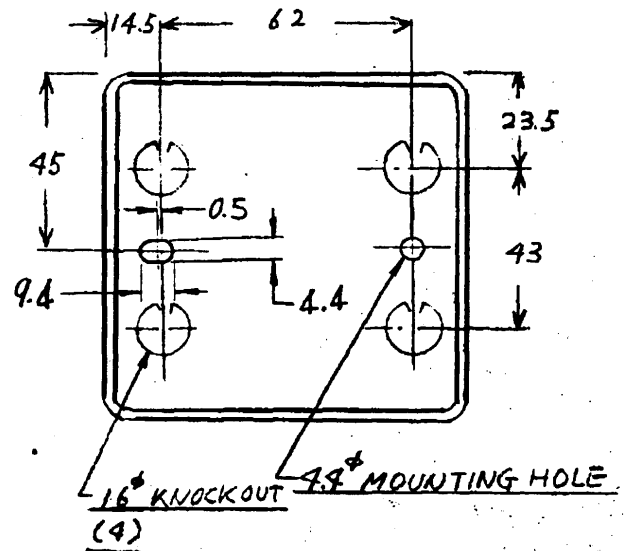
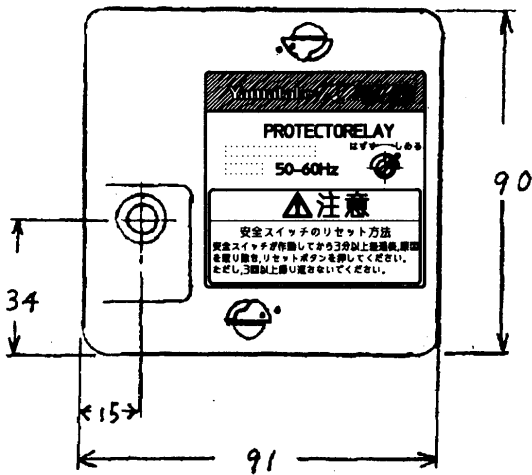

FIG. 6- SCHEMATIC DIAGRAM OF EXTERNAL CONNECTIONS

2.4.3 Schematic diagram of the R4313C

17/24  
NO. BLTN-03-17-C



Circuit diagram and connection diagram.

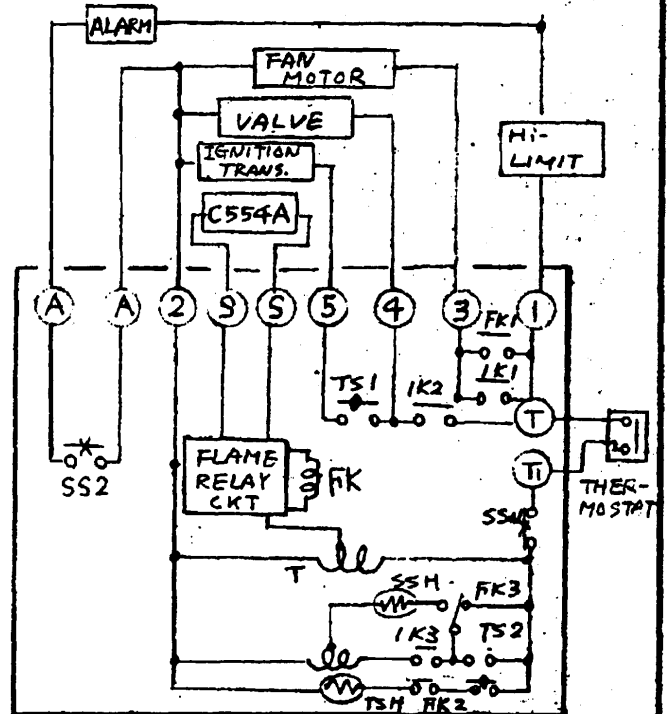

02	9.29.'95	JE095-0608	I.W	Y.N	
1	11-11-'72	Circuit change		H. Washi	
REV.	DATE	DESCRIPTION OF CHANGE.			
NAME		DRAWN	CHECKED	APPROVED	DATE
PROTECTORELAY		H. AIDA	H. Kishimoto	M. M.	9.29.'95
MODEL		DRAWING NO.			改番 REV NO.
R 4 3 1 3 C		AD1076E-3 2/2			02

SP.NO.	Yamatake Corporation	<div style="display: flex; justify-content: space-around; align-items: center;"> <div style="text-align: center;">製品仕様書</div> </div> <div style="text-align: center; border-top: 1px solid black; padding-top: 2px;">SPECIFICATIONS</div>
--------	----------------------	---

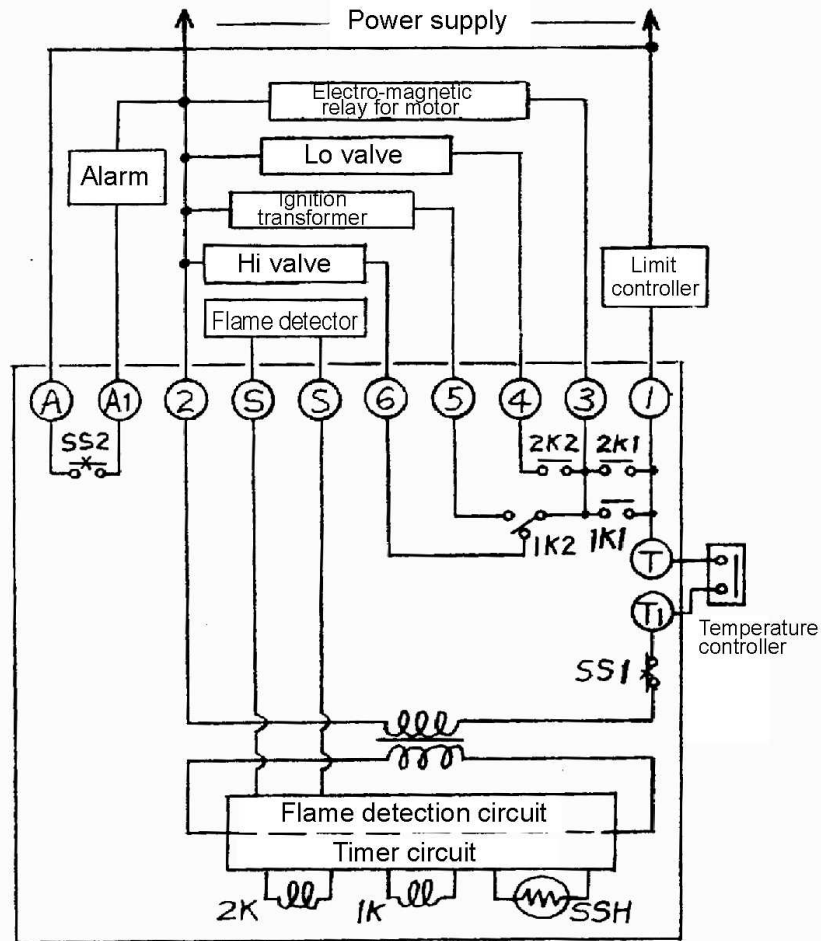

Circuit and wiring diagram

						作成DR. 山本 55-8-28	①	尺度 SCALE	記入のない公差 TOL. UNLESS NOTED
						検図CHK 白垣 55-9-3	形番 MODEL	R4313D1005,1013,150	
						認可APPD. 田中 55-9-5	名称 NAME	プロテクトリレー	
05	JEO95-0347	7-6-7	原田	真行寺	55-9-5	日付DATE	図番 NO.	AD1494	改番REV 05
改番 REV.	来歴 RECORD	日付 DATE	担当 BY	検閲 APPD.	7-6-7				3/4

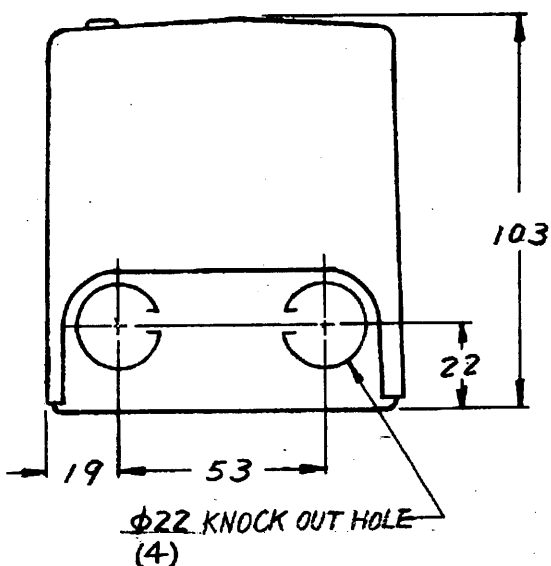
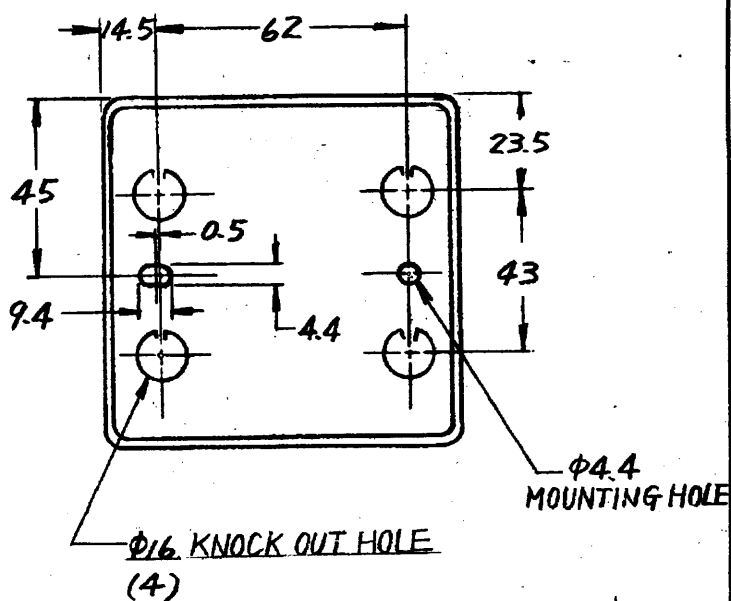
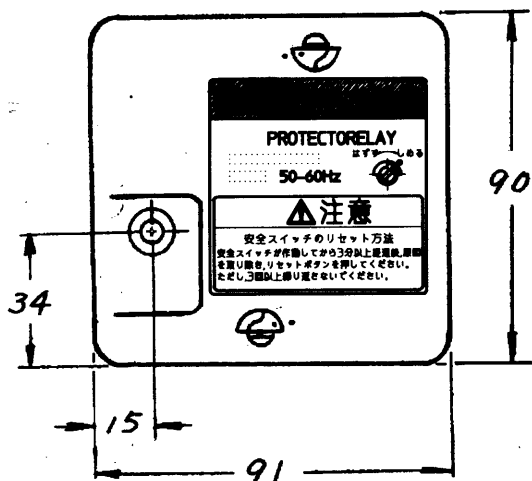

RATED VOLTAGE 200V 50-60HZ

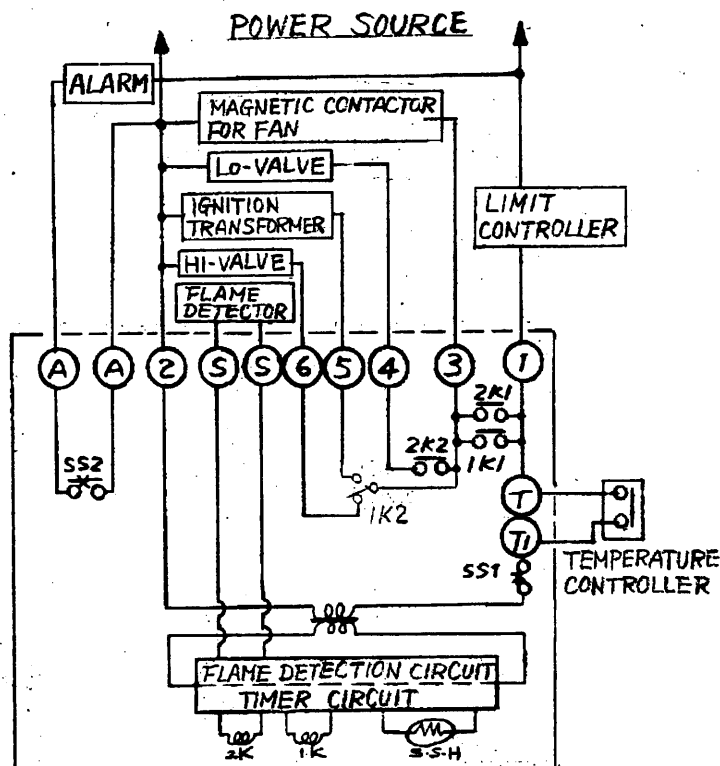

CIRCUIT AND WIRING DIAGRAM

02	9.29.'95	JE095-0608.	I.W	Y.N
1	Jun 2, '80	DRAWING CHANGED		Ishii
来歴 REV	日付 DATE	記 事 DESCRIPTION		
作成 DRWN.	検図 CHKD	承認 APPD.	日付 DATE	改 番 REV NO.
J. Sugisaki Mar. 3. '78	Y. Nakanishi Mar. 6 '78	H. Kishimoto Mar. 6 '78	9.29.'95	02

名 称  
NAME PROTECTORELAY

形 番  
MODEL R4313D500

図 番  
DRWG. NO. AD1672E 3/3

# 製品仕様書

形番 MODEL	R4313E1002, 1010	A	1474E
名称 NAME	PROTECTORELAY		

## SPECIFICATIONS

Voltage, Frequency and Power Consumption:

OS Number	Rated Voltage	Frequency	Power Consumption
R4313E1002	100V	50-60Hz	5W
R4313E1010	200V	50-60Hz	5W

Sequence: Non-recycling at flame-failure

Allowable Power Supply Voltage: 85% to 110% of rated voltage

Contact Ratings:

	120V		240V	
	Full Load	Locked Rotor	Full Load	Locked Rotor
Electro-magnetic relay for fan motor	2A	12A	11A	6A
Ignition Transformer	350VA			
Alarm	75VA			
Lo-Valve	100VA			
Hi-Valve				

Safety Switch Timing: 10 to 20 seconds  
(at rated voltage, 60Hz, room temperature)

Pre-purge Timing: 15 to 25 seconds  
(at rated voltage, 60Hz, room temperature)

Post-ignition Timing: 3 to 20 seconds  
(at rated voltage, 60Hz, room temperature)

Ignition Trial Timing: 4 to 6.2 seconds  
(at rated voltage, 60Hz, room temperature)  
3 to 7 seconds  
(at allowable voltage range, 50-60Hz and ambient temperature)

Flame Response Timing: 0.8 to 3 seconds  
(at rated voltage, 60Hz, room temperature)

Insulation Resistance: Should be more than 50 meg ohms at DC 500V megger between each terminal except terminal ⑤ and the base. (at room temperature and humidity)

Dielectric Strength: Device shall be capable of withstanding a potential of 1500VAC 50 or 60Hz for 1 minute or 1800VAC 1 second between each terminal except terminal ⑤ and the base. (at room temperature and humidity)

Ambient Temperature: -20 to 55°C

Ambient Humidity: 90% RH max. at 40°C

Life: 100,000 cycles or 10 years  
(at rated load, room temperature and humidity)

Color of Cover: Grey

Flame Detector used with: C554A

作成: DRWN	照査: CHKD	承認: APPD
Y. Yamaguchi	S. Shirayagi	K. Tomimura
78-5-26	78-5-26	78-5-30

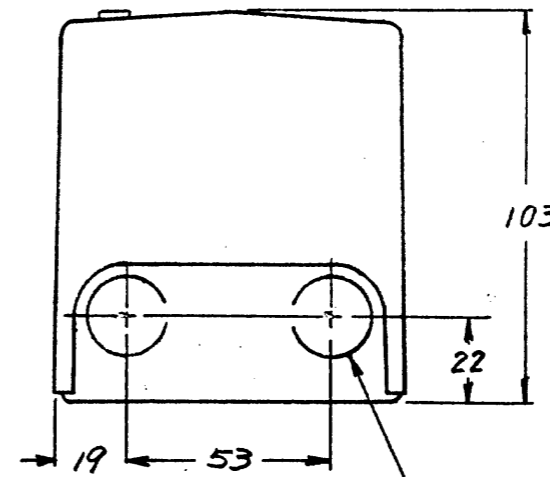
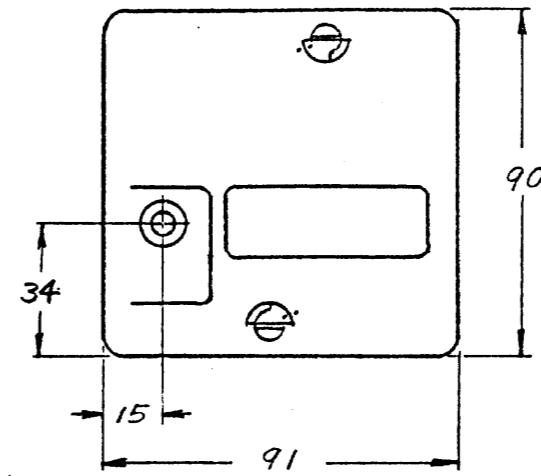

Φ22 KNOCK-OUT (4)

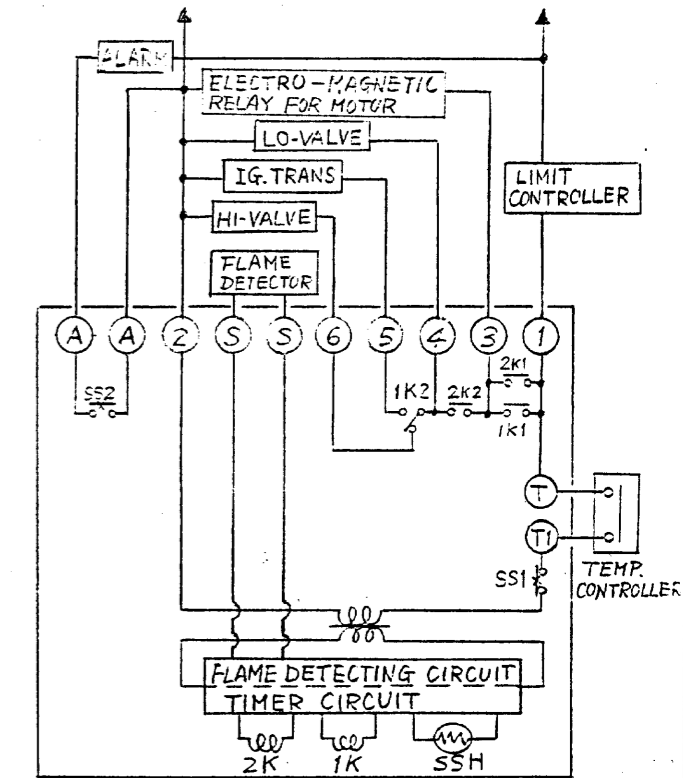
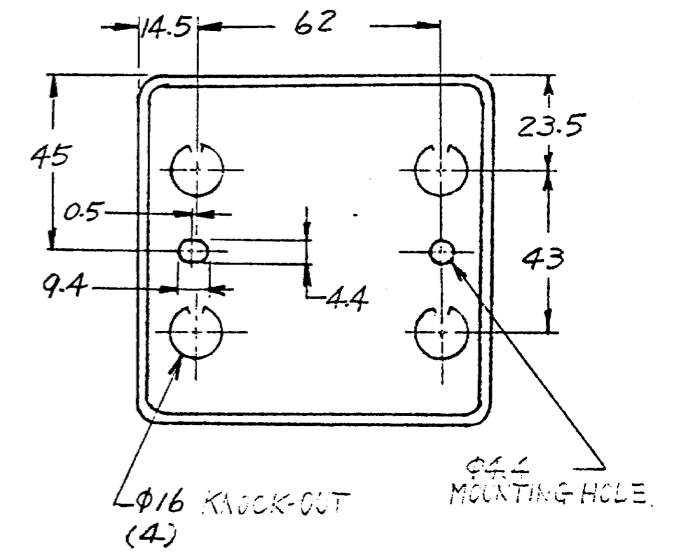

CIRCUIT AND EXTERNAL WIRING DIAGRAM

来歴 REV	日付 DATE	記 事	DESCRIPTION
作成	DRWN.	検図	CHKD
		承認	APPD.
		日付	DATE
		改番	REV NO.
Y. Suguchi	May. 26 '78	J. Wakemachi	May. 26 '78
		H. Kubonota	June. 12 '78

名称 NAME	PROTECTORELAY
形番 MODEL	R4313E1002, 1010
図番 DRWG. NO.	D 1474E

# 2.5 Schematic diagrams of the R4424C/D/E

## 2.5.1 Schematic diagram of the R4424C

### 製品仕様書

### SPECIFICATIONS

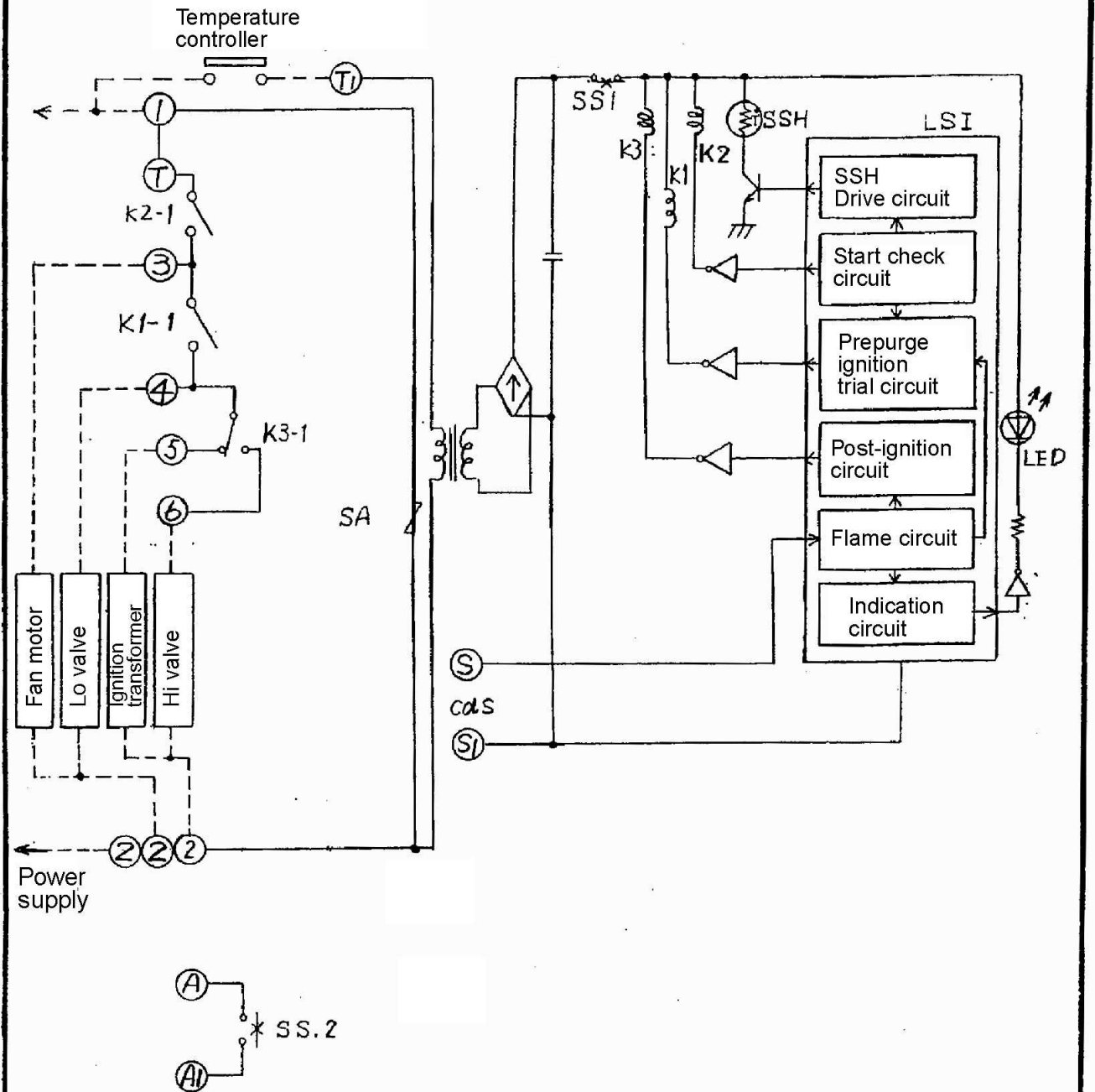

作成 DRWN.	検図 CHKD	承認 APPD.	日付 DATE
依藤 58-11-11	藤澤 58-11-11	岸 58-11-11	61-7-4
形番 MODEL R4424C104-1,204-1			
名称 NAME 7°口行7ト11L-			
図番 DRWG.NO.	10083	4/8	改番 REV.NO. 1

来歴 REV	日付 DATE	記事 DESCRIPTION	作成 DRWN	検図 CHKD
1	61-4-23	形番一部変更, 入数変更	菅谷	藤澤

製品仕様書

SPECIFICATIONS

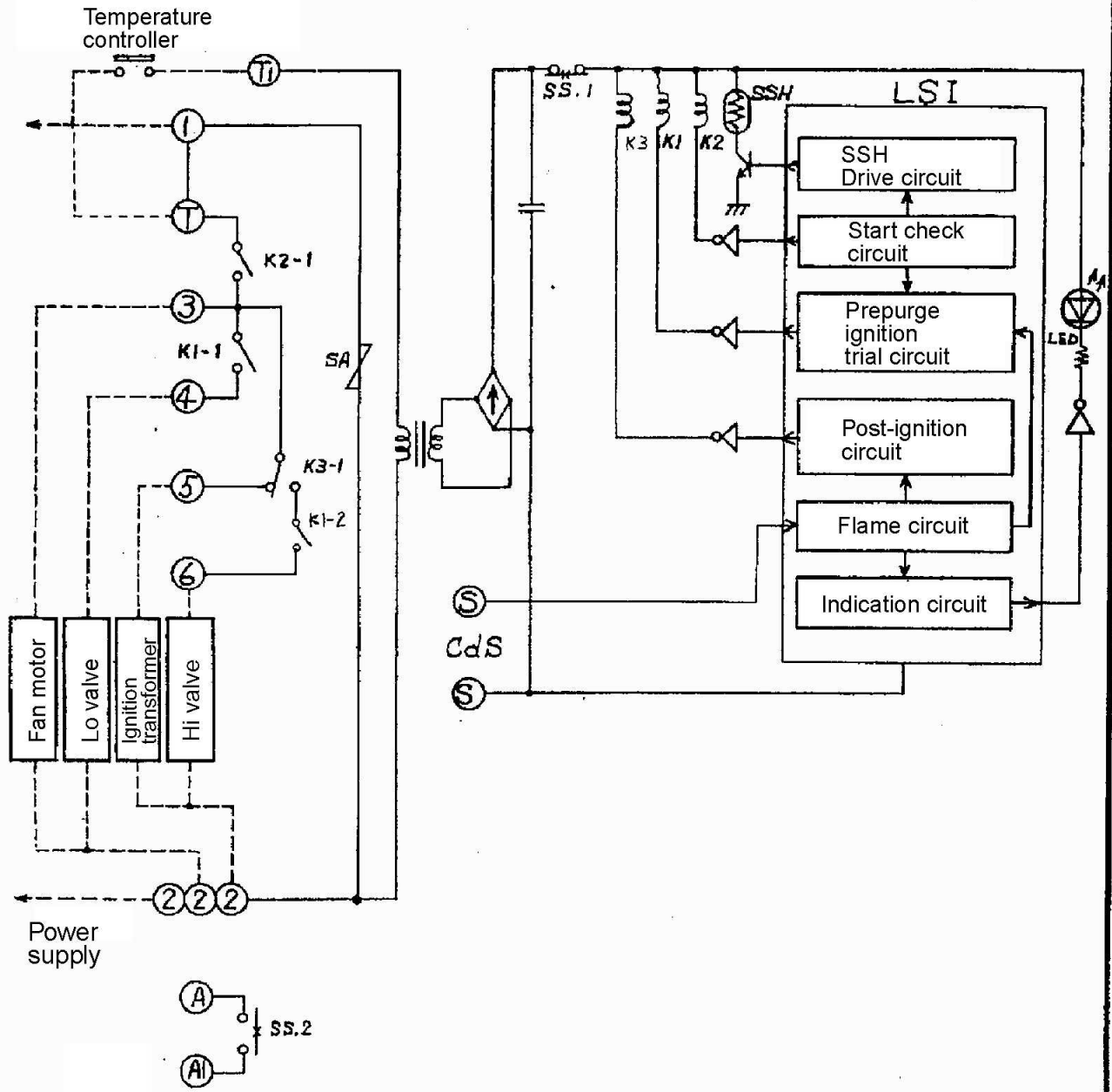

作成 DRWN.	検図 CHKD	承認 APPD.	日付 DATE
佐藤 敬彦	佐藤 敬彦	青	61-7-4
59-10-12	59-10-12	59-10-12	
形番 MODEL R4424D12H-1,22H			
名称 NAME 70口77H11L-			
REV	DATE	DESCRIPTION	DRWN
1	61-4-23	形番一部変更、パルス数変更	菅谷 敬彦
REV	DATE	DESCRIPTION	DRWN
図番	DRWG.NO.	10167	4/5
改訂	REV.NO.		1

A4 1/2 (注)

製品仕様書

SPECIFICATIONS

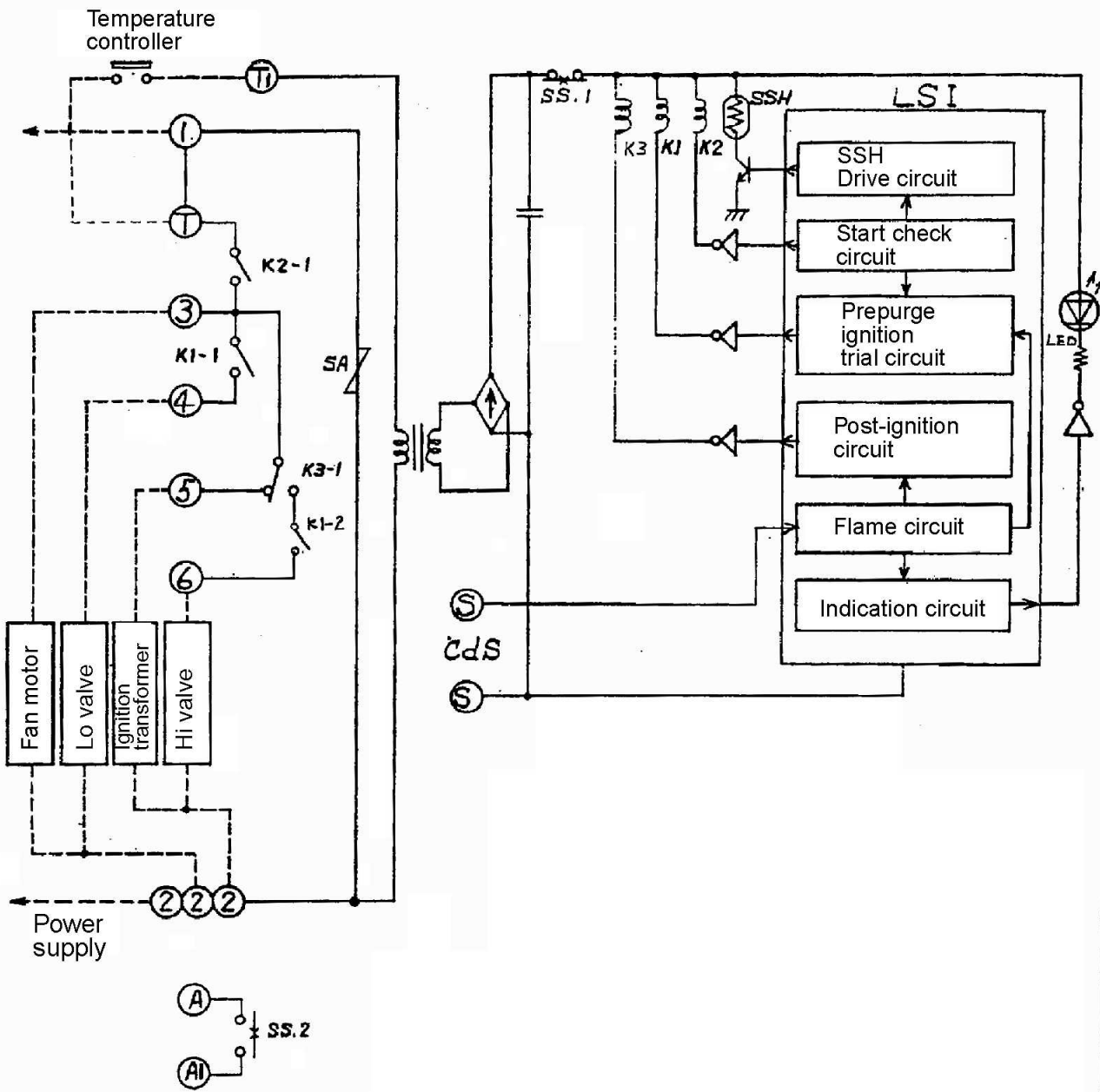

作成 DRWN.	検図 CHKD	承認 APPD.	日付 DATE
渡辺	森	岸	61-7-4
59-1-20	59-1-20	59-1-21	
形番	MODEL R44Z4D1001-1.1019-1		
名称	NAME 7077HL-		
図番	1011	4/5	改訂 REV.NO.
DRWG.NO.	1011 4/5		

1	61	形番一部変更、No.3数変更	菅谷 森
来歴 REV	日付 DATE	記事 DESCRIPTION	作成 DRWN 検図 CHKD

