

AUD300C2100 Advanced UV Sensor User's Manual



Thank you for purchasing the AUD300C 2100.

This manual contains information for ensuring correct use of the AUD300C 2100. It also provides necessary information for installation, maintenance, and troubleshooting.

This manual should be read by those who design and maintain devices that use the AUD300C2100.

Be sure to keep this manual nearby for handy reference.

Yamatake Corporation

RESTRICTIONS ON USE

This product has been designed, developed and manufactured for general-purpose application in machinery and equipment. Accordingly, when used in the applications outlined below, special care should be taken to implement a fail-safe and/or redundant design concept as well as a periodic maintenance program.

- Safety devices for plant worker protection
- Start/stop control devices for transportation and material handling machines
- Aeronautical/aerospace machines
- Control devices for nuclear reactors

Never use this product in applications where human safety may be put at risk.

REQUEST

Ensure that this User's Manual is handed over to the user before the product is used.

Copying or duplicating this User's Manual in part or in whole is forbidden. The information and specifications in this User's Manual are subject to change without notice.

Considerable effort has been made to ensure that this User's Manual is free from inaccuracies and omissions.

If you should find any inaccuracies or omissions, please contact Yamatake Corporation.

In no event is Yamatake Corporation liable to anyone for any indirect, special or consequential damages as a result of using this product.

©2004 Yamatake Corporation ALL RIGHTS RESERVED

SAFETY PRECAUTIONS

■ About Icons

The safety precautions described in this manual are indicated by various icons. Please be sure you read and understand the icons and their meanings described below before reading the rest of the manual.

Safety precautions are intended to ensure the safe and correct use of this product, to prevent injury to the operator and others, and to prevent damage to property. Be sure to observe these safety precautions.



 **WARNING**

Warnings are indicated when mishandling this product might result in death or serious injury.









 **CAUTION**

Cautions are indicated when mishandling this product might result in minor injury to the user, or only physical damage to the product.











■ Examples

	Use caution when handling the product.
	The indicated action is prohibited.
	Be sure to follow the indicated instructions.

WARNING

	Do not combine the AUD300C with a unit other than Yamatake's flame safeguard control AUR series.
	Do not use this unit for detection of ultraviolet rays other than those of the burner flame. If this unit responds to other ultraviolet rays, the status that the flame failure occurs in the burner is determined as flame presence. Thus, the fuel flows out continuously, causing an explosion.
	Before removing or mounting the AUD300C, be sure to turn the power OFF. Failure to do so might cause electric shock.
	Before wiring the AUD300C, be sure to turn the power OFF. Failure to do so might cause electric shock.
	To prevent an explosion trouble, carry out the pilot turndown test firmly. If the AUD300C detects a small pilot flame, which cannot ignite the main burner, it is determined that flame failure does not occur in the flame safeguard control even though the flame failure occurs in the main burner. Thus, the fuel is supplied continuously, causing an explosion accident, resulting in a serious hazard.
	When performing the pilot turndown test repeatedly, stop the equipment completely every time the pilot turndown test is completed in order to completely discharge the unburnt gas or oil accumulated in the combustion chamber or flue. If the unburnt gas or oil is not discharged completely, this might cause an explosion accident.
	Do not touch terminals F or G on the AUD300C or on the AUR immediately after the power to the AUR has been turned OFF. The F-terminal and G-terminal are still electrically alive within 1 min after the power has been turned OFF, causing an electric shock hazard.
	When measuring the voltage between the F-terminal and G-terminal of the AUD300C in the wiring check, do not touch any terminal by bare hand. Doing so might cause an electric shock.

CAUTION

	<p>The AUD300C is specially designed for intermittent burner operation (system is started and stopped once or more within 24 hours.) and continuous burner operation (system continues the combustion for 24 hours or longer). The AUR series having the self-check function must be used as an amplifier to be combined.</p>
	<p>Only authorized personnel who have the technical skill about the combustion equipment and flame safeguard control must carry out the mounting, wiring, inspection, adjustment, and maintenance work.</p>
	<p>If the AUD300C is operated in an atmosphere where any steam, smoke, oil mist, dust, and/or organic solvent exist that hinder the penetration of ultraviolet rays, take appropriate corrective measures.</p>
	<p>When using multiple burners, mount the AUD300C at a position where it detects the flame of only the burner to be monitored.</p>
	<p>Carry out the wiring work in conformity with the specified standards.</p>
	<p>Always separate the signal cables of the AUD300C from the high voltage cables of the ignition transformer and power cables, and then always run the signal cables in a different conduit tube.</p>
	<p>After the wiring work has been completed, always check that the wiring is correct. Incorrect wiring may cause damage or malfunction.</p>
	<p>Only authorized personnel who have the technical skill about the combustion equipment and flame safeguard control must carry out the pilot turndown test.</p>
	<p>The service life of the tube unit AUD10C built-into the AUD300C is 3 years or 25,000 operation hours. To ensure the operational safety, replace the tube unit with a new one within this service life.</p>
	<p>Do not transport the AUD300C with it mounted on the combustion equipment. The impact or vibration during transportation may cause the AUD300C to malfunction. Before starting the transportation, remove the AUD300C and put it in the specially designed packing box.</p>
	<p>Replace the shutter unit AUD50A with a new one at a reference replacement interval of 3 years.</p>

The Role of This Manual

There are nine manuals have been prepared for the AUD300C, AUR series. Read the manual according to your specific requirements. The following lists all the manuals that accompany the AUD300C, AUR series and gives a brief outline of the manual: If you do not have the required manual, contact Yamatake Corporation or your dealer.

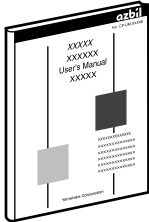

AUD300C2100 Advanced UV Sensor **Manual No.CP-SP-1170E**

This manual
The manual describes the mounting, wiring, maintenance and inspection, and troubleshooting when the AUD300C is built-into the combustion equipment.

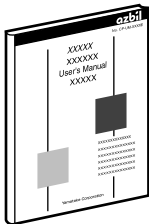

AUR300C Advanced UV Relay **Manual No.CP-SP-1142E**

The personnel in charge of design, mounting, operation, and maintenance of the combustion equipment using the AUR300C must read this manual. The manual describes the mounting, wiring, trial-run adjustment, and maintenance and inspection of the AUR300C.

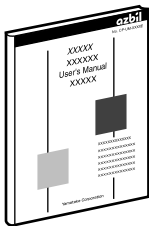

AUR350C Advanced UV Relay with Communications **Manual No.CP-SP-1175E**

Personnel in charge of design, mounting, operation, and maintenance of combustion equipment using the AUR350C should read this manual. It describes the mounting, wiring, trial-run adjustment, maintenance, inspection of the AUR350C.

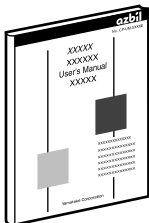

AUR450C Dynamic Self Check Burner Controller **Manual No. CP- SP-1264E**

This manual should be read by personnel using the AUR450C for the first time, those in charge of designing combustion equipment that uses the AUR450C or designing the hardware for mounting the device in a control panel, and personnel performing maintenance.

The manual gives an overview of the product, its mounting and wiring for connection to other equipment, its operation, trial-run adjustment, maintenance and inspection, and specifications.

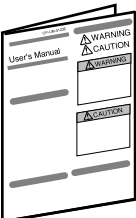

FSP300C Flame Simulator **Manual No. CP-SP-1209E**

It should be read in advance by those who use the FSP300C to check the operation of the AUD300C/500C and the AUR300C/350C/400C/450C. This manual describes installation, operation, and precautions for use of the FSP300C.

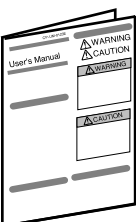

FSP350A Checker for AUR300C/350C **Manual No. CP-SP-1210E**
FSP450A Checker for AUR450C **Manual No. CP-SP-1211E**

It should be read in advance by those who use the FSP350A to check the operation of the AUR300C/350C, and those who use the FSP450A to check the operation of the AUR450C. This manual gives important information and precautions for use of the FSP350A and FSP450A.

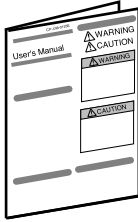

FSP136A Analog Flame Meter

Manual No. CP-SP-1212E

It should be read in advance by those who use the FSP136A to check the voltage of the AUR300C/350C/400C/450C. This manual gives important information and precautions for use of the meter.

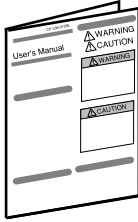

AUD60A2100 Maintenance Kit for AUD

Manual No. CP-UM-5441E

This manual describes a way of change the maintenance kit for the AUD300C2100, that is composed of the tube unit, the shutter unit and the O-ring etc. as consumables.

Conventions Used in This Manual

The following conventions are used in this manual:

! Handling Precaution

: Handling Precautions indicate items that the user should pay attention to when handling the AUD300C.



: This indicates the item or page that the user is requested to refer to.

(1), (2), (3)

: The numbers with the parenthesis indicate steps in a sequence or indicate corresponding parts in an explanation.

>>

: Indicates the result of operation or the state of the device after operation.

Contents

SAFETY PRECAUTIONS

The Role of This Manual

Conventions Used in This Manual

Chapter 1. OVERVIEW

- Overview..... 1
- Features 1
- Part names..... 1
- Model No..... 2
- Configuration 2

Chapter 2. MOUNTING

- Before mounting this unit..... 3
- Monitoring of burner flame..... 3
- Mounting position..... 4
- Mounting posture..... 5
- Mounting of monitoring pipe..... 6
- Mounting procedure 8

Chapter 3. WIRING

- Wiring diagram..... 9
- Checking of wiring..... 10

Chapter 4. ADJUSTMENT

- Before measurement of flame voltage..... 11
- Measurement of flame voltage..... 11
- Pilot turndown test 12
- Ignition spark response test 13
- Firmly mounting of monitoring pipe 13
- Final inspection..... 13

Chapter 5. TROUBLESHOOTING

Chapter 6. MAINTENANCE AND INSPECTION

- Periodic inspection 15
- Replacement of maintenance kit..... 16
- Replacement of tube unit..... 16
- Replacement of shutter unit 17

Chapter 7. SPECIFICATION

- Specification..... 19
- Dimensions..... 20

Chapter 1. OVERVIEW

■ Overview

This advanced ultraviolet sensor AUD300C2100 (hereafter referred to as the AUD300C) is a flame detector designed to sense the ultraviolet ray radiation of the oil or gas burner flame. This unit is used in combination with the dedicated Advanced Ultraviolet Relay (hereafter referred to as AUR series). Any malfunction that has occurred in the AUD300C or AUR series can be detected by the accurate dynamic continuous self-check function of the built-in shutter driven by the AUR series, ensuring highly reliable combustion safety control.

■ Features

- Maintenance parts such as the tube unit AUD10C and shutter unit AUD50A can be handled as a single unit. This ensures easy replacement and maintenance work.
- As for a flame sensor for the self-check, the AUD300C is compact and lightweight. This ensures free burner mounting.
- The operating ambient temperature is 100°C and the protection structure is IP66. This ensures excellent environment-proof performance.
- The vertical mounting is possible and the maximum wiring distance is 200 m. This ensures flexible construction work.

■ Part names

● Main unit

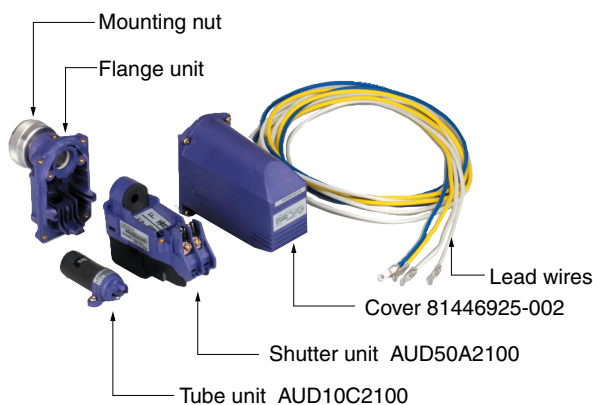

● Tube unit AUD10C2100

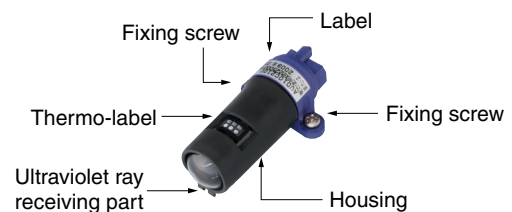

● Shutter Unit AUD50A2100

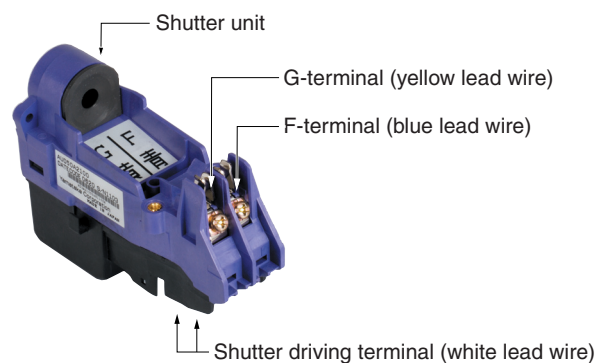

■ **Model No.**

Model No.	Description
AUD300C2100	Advanced UV Sensor
AUD300C210D	Advanced UV Sensor with inspection certificate
AUD300C210DT	Advanced UV Sensor with inspection certificate and tropicalization treatment applied

● **Applicable standards**

UL certificated; UL file No.MH27717

■ **Configuration**

● **Combined combustion safety controller**

● **AUR300C/350C**

Series	Basic Model No.	Function	Flame response	Power supply voltage	Option	Contents
AUR						Advanced UV relay
	300C					
	350C					With communication function
		1				Fixed
			2			Flame response 1.5s(nominal value)
			3			Flame response 3.0s(nominal value)
				1		100Vac
				2		200Vac
					00	Without option
					D0	Inspection certificate provided
					T0	Tropicalization treatment applied
					DT	Tropicalization treatment applied and inspection certification provided

● **AUR450C**

Basic model No.	Safety time	Standard compliance	Flame failure response time	Power supply	Add-processing1	Add-processing2	Description
AUR450C							Dynamic self check burner controller
	4						4±1 s
	8						8±2 s
		2					With standard compliance
			2				1.5 s maximum (2 s maximum)
			3				3 s maximum (4 s maximum)
				1			100 Vac CE, UL standards
				2			200 Vac CE standards
				3			120 Vac CE, UL standards
				5			230 Vac CE standards
					0		-
						00	No additional processing
						D0	Inspection certification provided
						T0	Tropicalization treatment applied
						DT	Tropicalization treatment applied and inspection certification provided

● **Maintenance parts and Optional parts**

Description	Model No.
Maintenance kit	AUD60A2100
Tube unit	AUD10C2100
Shutter unit	AUD50A2100
Cover	81446925-002
Bushing 1 X 3/4	81409780-001
Analog flame meter	FSP136A100

Chapter 2. MOUNTING

WARNING



Before removing or mounting the AUD300C, be sure to turn the power OFF. Failure to do so might cause electric shock.



Do not use the AUD300C for detection of ultraviolet rays other than those of the burner flame. If the AUD300C responds to other ultraviolet rays, the status that the flame failure occurs in the burner is determined as flame presence. Thus, the fuel flows out continuously, causing an explosion.

CAUTION



Only authorized personnel who have the technical skill about the combustion equipment and flame safeguard control must carry out the mounting, wiring, inspection, adjustment, and maintenance work.



If the AUD300C is operated in an atmosphere where any steam, smoke, oil mist, dust, and/or organic solvent exist that hinder the penetration of ultraviolet rays, take appropriate corrective measures.



When using multiple burners, mount the AUD300C at a position where it detects the flame of only the burner to be monitored.

■ Before mounting this unit

- To mount the AUD300C correctly, thoroughly read the instruction manuals published by burner, boiler, and/or other equipment manufacturers. Make the proper mounting plan while referring to such instruction manuals.
- It is necessary that the AUD300C actually monitors the flame. As long as the overall layout and temperature around the burner and other limitations permit, mount the AUD300C as close to the flame as possible. As the AUD300C is mounted closer to the burner nozzle, the detection amount of the ultraviolet ray radiation will increase.
- Mount the AUD300C at a position far from the ignition transformer. Additionally, mount the ignition transformer as close to the burner as possible, and then ground it firmly.

■ Monitoring of burner flame

● Monitoring of only pilot flame (Continuous pilot, intermittent pilot)

The main burner must be ignited firmly with the minimum pilot flame that the AUD300C can detect. Therefore, throttle the pilot fuel manual valve until the main burner is ignited barely. Mount the AUD300C under these conditions so that the unit monitors only the top of the pilot flame. Put the monitoring area as close to the top of the flame as possible so that the unit monitors the pilot flame along with the axis of the pilot flame.

● Monitoring of both pilot flame and main flame (Continuous pilot, intermittent pilot)

Mount the AUD300C so that the unit monitors an area where the pilot flame intersects the main flame.

- **Monitoring of only main flame (Interrupted pilot)**

Mount the AUD300C so that the unit monitors any status of the main flame (most stable part of the flame in both the low-combustion and high-combustion).

In the special combustion, it is recommended to use two units in order to monitor the main flame of each of the high-combustion and low-combustion.

- **Monitoring of pilot flame and main flame individually (continuous pilot or intermittent pilot)**

Mount the AUD300C so that the sensor for monitoring the main flame does not mistakenly detect the pilot flame. If the sensor for the main flame detects the pilot flame, the fuel supply will not be shut down if the main burner fails, since the flame failure will not be detectable.

- **Multiple burners existing in one combustion chamber**

Mount the AUD300C on each burner and carry out the mounting work so that the unit does not detect the flame of other burner incorrectly.

Additionally, the tube unit AUD10C of the AUD300C may produce the electrical discharge phenomenon inside the tube. This electrical discharge may emit the ultraviolet rays from the tube. Therefore, when using multiple units, adjust their positions so that the ultraviolet ray radiation from other tube unit is not detected.

- **Redundant system (Duplicate monitoring)**

To increase the reliability of the system and avoid unnecessary shut-off as much as possible, the AUD300C is combined with the AUR series and the redundant system is constructed so that two sets monitor the flame of one burner.

If two AUR series units detect the flame failure at the same time, the system must be shut-off. If either flame detector does not output the flame signal or if any dummy signal exists, the alarm is given, but the system continues the combustion. This avoids any unnecessary shut-off of the system caused by this unit, combustion safety control unit, or oscillating flame. The highly reliable flame monitor can be achieved.

■ Mounting position

Determine an optimal mounting position of the AUD300C while carefully observing the following items:

- **Temperature**

Mount this unit in a place where the operating temperature range is -20°C to +100°C.

! **Handling Precautions**

- If the above temperature range is not observed, this may cause the tube unit AUD10C or shutter unit AUD50A assembled to the AUD300C to malfunction or unnecessary shut-off.
- If the actual temperature may exceed the operating temperature range, put an appropriate thermal insulation plate between the combustion chamber and the AUD300C or carry out the air purging to put the temperature within the operating temperature range.

● Vibration

Mount the AUD300C in a place where the acceleration is 4.9 m/s^2 or less.

! Handling Precautions

- The vibration may cause the service life of the tube unit AUD10C or shutter unit AUD50A to be shortened, improper operation, or malfunction.

● Outdoor

Mount appropriate roofs or eaves to avoid rain water.

! Handling Precautions

- There might be a case that the body color of the AUD300C is changed by the influence of sunlight or other causes. But, there is no problem for the product functions or operations.

■ Mounting posture

The allowable range of the mounting posture is that the upper limit is 90° (conduit tube port becomes horizontal) and the lower limit is 45° .

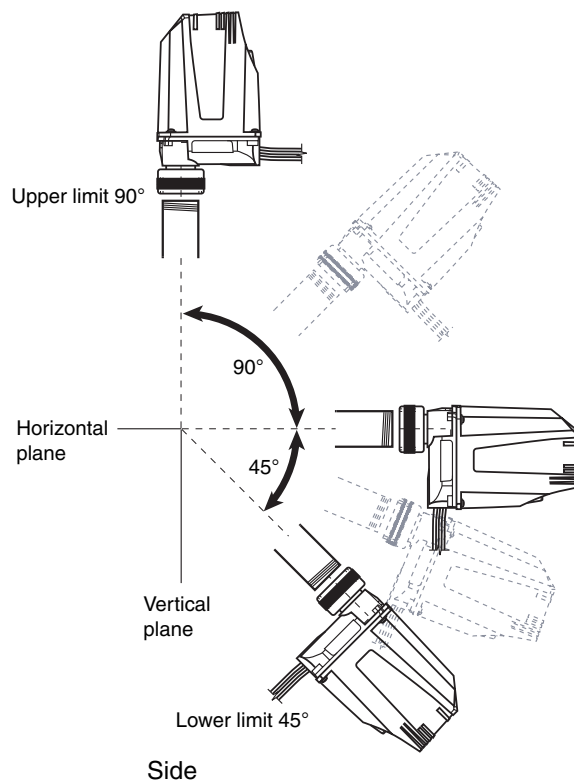

! Handling Precautions

- Mount this unit at an appropriate angle so that it monitors the burner from the upper slanted position. If this unit is mounted so that it monitors the burner from the lower slanted position or horizontal position, dust or soot may accumulate on the monitoring window or in the monitoring pipe. This may block the ultraviolet rays, causing the flame not to be detected.

■ Mounting of monitoring pipe

● Materials of monitoring pipe

Use a monitoring pipe with the black inside wall. If a pipe with the stainless steel or galvanized inside wall is used, the diffused reflection of the ultraviolet rays occurs inside the pipe, causing a malfunction.

● Size of monitoring pipe

To detect the ultraviolet rays radiation of the flame at its optimal level, it is necessary to widen the light receiving area of the AUD300C. If a recommended flame voltage of 1.5V or more cannot be kept, make the monitoring pipe thicker to receive a sufficient amount of ultraviolet rays.

- Use the monitoring pipe as thick as possible and connect the pipe to this unit with the reducing socket.
- Make the length of the monitoring pipe as short as possible. However, always keep the operating ambient temperature within 100°C.

● Mounting space

Keep a sufficient space to allow easy maintenance and inspection, and service work.

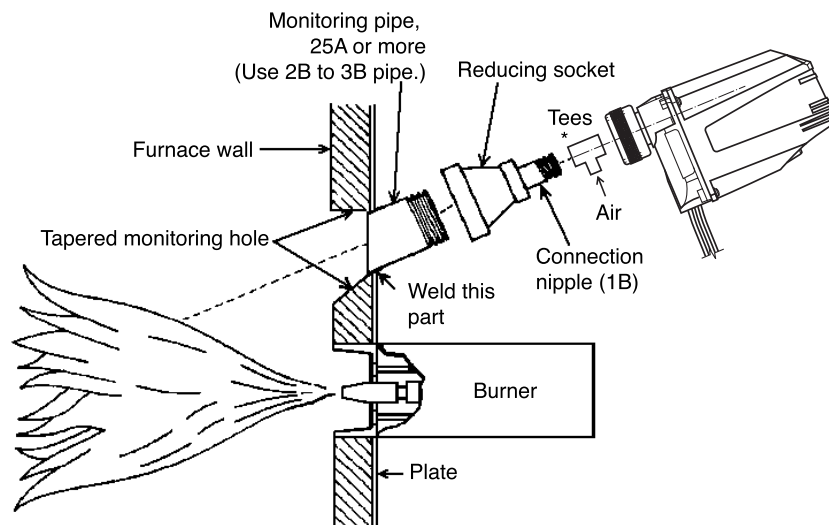

* If the air purging is needed, tees are used to supply the air.

! Handling Precautions

- Mount this unit so that its monitoring direction intersects the flame axis at an as small angle as possible. This ensures a wide intersection area of the monitoring area between the flame and this unit. Thus, the detection amount of ultraviolet ray radiation becomes large.

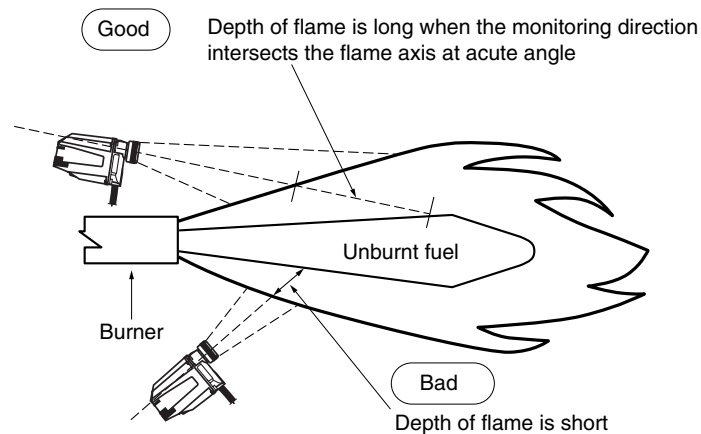

● Temporary welding for positioning of monitoring pipe

- (1) Prepare the monitoring pipe and make the mounting hole.

Make the mounting hole for the monitoring pipe at the selected monitoring pipe mounting position.

Perform the screw threading of one end of the monitoring pipe and cut the monitoring pipe to a desired length so that its length is as short as possible.

- (2) Weld the monitoring pipe temporarily.

Weld the monitoring pipe temporarily to the plate of the combustion chamber, such as boiler.

At this time, do not weld the monitoring pipe completely since the inspection and adjustment are required until the flame is detected properly.

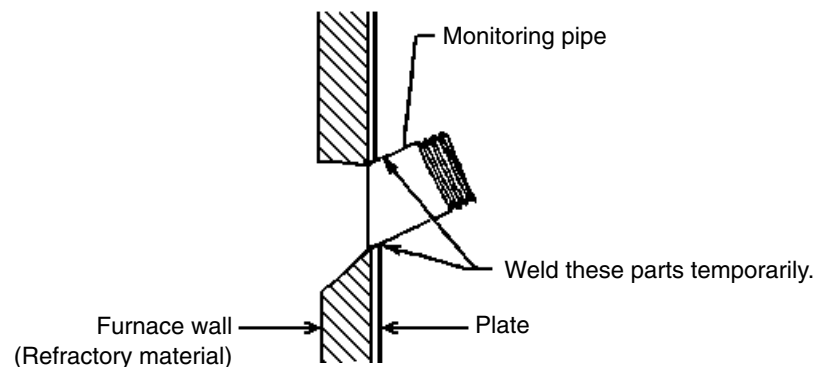

- (3) Carry out the air purging of the monitoring pipe.

The air purging of the inside of the monitoring pipe is useful to cool the AUD300C and keep the monitoring area clean.

In particular, if the ambient temperature of the AUD300C exceeds 100°C, the cooling, such as air purging is needed.

- If the inside of the furnace is a type of induced draft, make an air purging hole in the monitoring pipe.
- If the forced type furnace is used, connect an air purging supply pipe.

■ Mounting procedure

When mounting the AUD300C on a monitoring pipe, proceed as follows:

● Check item

File the monitoring pipe in advance to eliminate burrs and protrusions.

● Mounting

- (1) Hold the unit securely with one hand to prevent it from rotating.
- (2) Tighten the mounting nut approximately 4 turns with the other hand until the unit is held securely in place.
- (3) Make sure the unit is properly aligned in the vertical plane when viewed from the front.

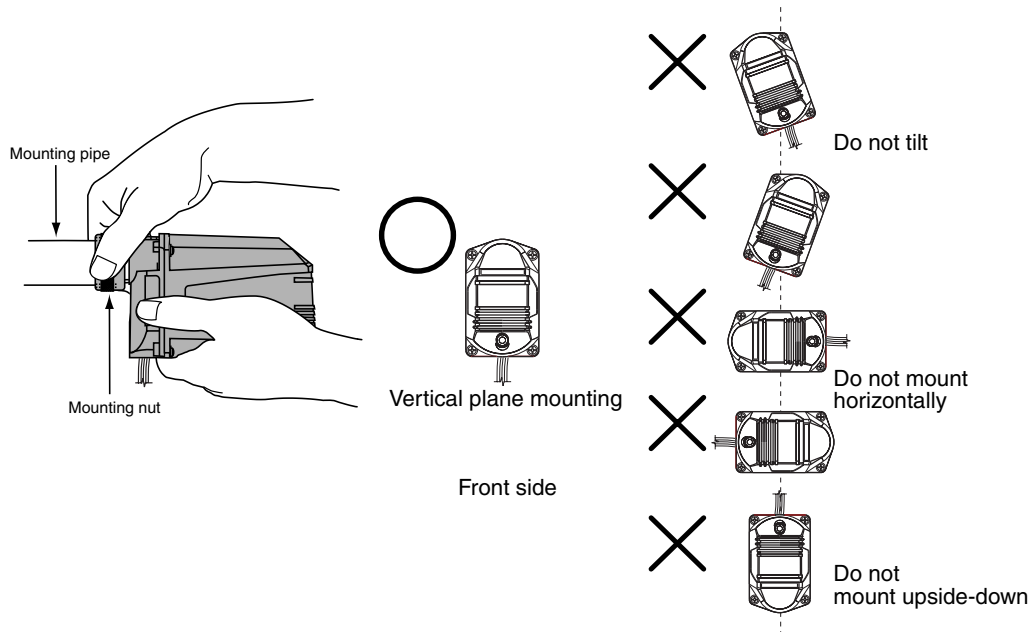

! Handling Precautions

- Be sure the AUD300C is properly aligned vertically when seen from the front. If not, the shutter in the AUD50A shutter unit may be damaged or malfunction.
If this unit is not mounted correctly, this may cause the shutter of the shutter unit AUD50A to be damaged or malfunction.
- File any burrs or protrusions from the monitoring pipe. If the packing in the mounting nut is damaged, any chance of leakage may be caused.
- Do not use a tool such as pipe wrench when tightening the mounting nut. Excessive torque by a tool could damage the packing and compromise the seal.
- Do not adjust the mounting pose by forcibly holding the unit or wiring pipe. Failure to do so may damage the packing and compromise the seal.

Chapter 3. WIRING

⚠ WARNING



Before wiring the AUD300C, be sure to turn the power OFF. Failure to do so might cause electric shock



When measuring the voltage between the F-terminal and G-terminal of the AUD300C in the wiring check, do not touch any terminal by bare hand. Doing so might cause an electric shock.

⚠ CAUTION



Only authorized personnel who have the technical skill about the combustion equipment and flame safeguard control must carry out the mounting, wiring, inspection, adjustment, and maintenance work.



Always separate the signal cables of the AUD300C from the high voltage cables of the ignition transformer and power cables, and then always run the signal cables in a different conduit tube.

■ Wiring diagram

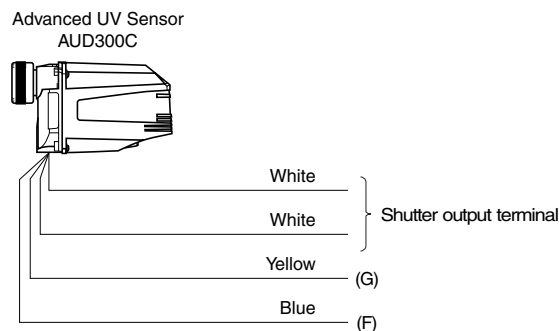

When performing the wiring work, put all lead wires used for the connection with the AUR series in the conduit tube or conduit box. Additionally, set these lead wires separated from other power cables.

⚠ Handling Precautions

- Never set the lead wires to the AUD300C in the same conduit tube containing the high voltage cables, such as power cables or ignition transformer cables.
- Put the high voltage cables of the ignition transformer and the grounding cables in the same conduit tube. At the same time, ground one end of this conduit tube firmly. In particular, this caution must be observed strictly when using an automotive spark plug.
- If the surge of the ignition transformer adversely affects the AUD300C, ground both ends of the conduit tube between the AUD300C and combustion safety control unit or change the cable wiring route.

■ Checking of wiring

Before applying the voltage to this unit, check that the wiring is correct.

● Procedures

(1) Remove the cover of this unit and take out the tube unit AUD10C. For details about how to take out the tube unit

☞ refer to the section, Replacement of tube unit, in Chapter 6.

(2) Turn ON the power to the AUR300C.

(3) Measure the DC voltage between the F-terminal and G-terminal with a multi-meter or digital voltmeter.

(4) Connect the positive probe to the G-terminal (yellow lead wire) and the negative probe to the F-terminal (blue lead wire).

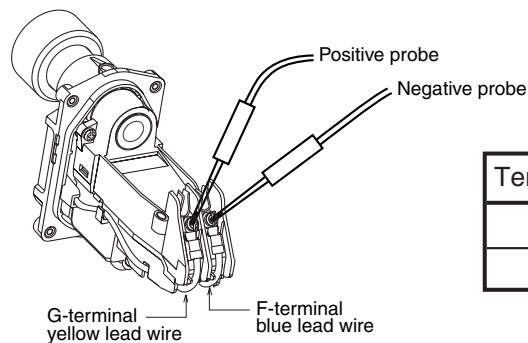

Terminal	Probe	Voltage
ⓕ	-	DC160 to 220V
ⓖ	+	

>> If a voltage of 160Vdc to 220Vdc is output, it is determined that the wiring work has been performed correctly. If the measured DC voltage is a negative value, the wiring to the F-terminal and G-terminal is connected reversely.

(5) Next, measure the DC voltage between the shutter voltage S1-terminal and S2-terminal (both are white lead wires).

! Handling Precautions

The polarities of the S1-terminal and S2-terminal are not specified. When measuring the voltage with an analog multi-meter, set a large voltage range so that the indication needle does not deflect over the negative scale to check the polarities. After that, measure the shutter voltage.

>> If the indication needle swings in a range of 15Vdc to 24Vdc, it is determined that the wiring is connected correctly.*

If the indication needle of the multi-meter shows 24Vdc constantly or if it shows 0V, the wiring may be incorrect.

* If a flame exists, the shutter voltage swings within a range of 0Vdc to 24Vdc.

(6) Mount the tube unit AUD10C 1 min. or longer after the power to the AUR300C has been turned OFF.

Chapter 4. ADJUSTMENT

■ Before measurement of flame voltage

Before measuring the flame voltage, check the operation of this unit through the flame voltage output terminals of the AUR300C.

Model No.	Flame voltage output terminals
AUR300C	Terminal 9 (+)
AUR350C	Terminal 10 (-)
AUR450C	Positive terminal, Negative terminal

- (1) Connect an analog flame meter (FSP136A100) to the flame voltage output terminals of the AUR300C.
- (2) Light a lighter in front of the ultraviolet ray receiving part of this unit to check that the voltage is output correctly.

! Handling Precautions

- When using an open flame, check that there is no flammable gas around this unit.

■ Measurement of flame voltage

If both pilot flame and main flame exist, measure each flame voltage. Additionally, measure the flame voltage in the maximum combustion and minimum combustion states.

- (1) Mount the monitoring pipe on this unit temporarily.
- (2) Start the combustion of the burner.
- (3) To determine an optimal monitoring position, measure the flame voltage of the AUR300C with the analog flame meter (FSP136A100) meter while moving the monitoring pipe position little by little in order to find a position where as highly stable voltage as possible is shown.

Recommended flame voltage	Inspection item
2.0 to 4.0Vdc (flame response 1.5s) 1.5 to 4.0Vdc (flame response 3s) (The flame voltage may fluctuate in a range of 0.1 to 0.3V synchronized with the shutter operation of this unit.)	Check that the flame is monitored correctly. Check that the light receiving lens of this unit is not contaminated. Check that foreign matter, such as soot is not caught in the monitoring pipe.

! Handling Precautions

- When the flame voltage exceeds 4Vdc, provide an orifice sheet into the flange unit to limit the quantity of ultraviolet rays. Excess quantity of ultraviolet rays might cause malfunction by the diffused reflection of ultraviolet rays coming into the tube unit even when the shutter is closed.

■ Pilot turndown test

This test is intended to check that the flame is correctly carried over to the main burner when the AUD300C detects the pilot flame if the gas pressure and air pressure are changed to their worst conditions.

WARNING



To prevent an explosion trouble, carry out the pilot turndown test firmly. If the AUD300C detects a small pilot flame, which cannot ignite the main burner, it is determined that flame failure does not occur in the flame safeguard control even though the flame failure occurs in the main burner. Thus, the fuel is supplied continuously, causing an exposition accident, resulting in a serious hazard.



When performing the pilot turndown test repeatedly, stop the equipment completely every time the pilot turndown test is completed in order to completely discharge the unburnt gas or oil accumulated in the combustion chamber or flue.
If the unburnt gas or oil is not discharged completely, this might cause an explosion accident.

CAUTION



Only authorized personnel who have the technical skill about the combustion equipment and flame safeguard control must carry out the mounting, wiring, inspection, adjustment, and maintenance work.



Only authorized personnel who have the technical skill about the combustion equipment and flame safeguard control must carry out the pilot turndown test.

For details about how to carry out the pilot turndown test, refer to the user's manual for AUR series combined with the AUD300C, as well as the instruction manuals published by equipment manufacturers.

■ Ignition spark response test

	⚠ WARNING
⊘	Do not use the AUD300C for detection of ultraviolet rays other than those of the burner flame. If the AUD300C responds to other ultraviolet rays, the status that the flame failure occurs in the burner is determined as flame presence. Thus, the fuel flows out continuously, causing an explosion.

● Procedures

- (1) Close the manual shut-off valves of the pilot burner and main burner.
- (2) Operate the burner to perform the ignition operation. The ignition spark is then started. At this time, check that the flame relay (K2) of the AUR300C is not excited. (K2 is the flame relay for the AUR300/350, and K6 is the flame relay for the AUR450.)
- (3) If the flame relay is excited, adjust the monitoring point of this unit again to avoid the influence of the ignition spark and its reflection.

ⓘ Handling Precautions

- The table below shows various sources other than flame, that may activate the AUD300C. Check that the AUD300C control action is not influenced under all operating conditions.

Examples:

Ultraviolet ray sources	Scorching furnace wall with a temperature of 1370°C or more (within 50 cm of furnace wall)
	Ignition transformer and welding arc spark (lightning)
	Gas laser
	Sunlamp
	Disinfecting lamp, ultraviolet ray radiation lamp, fluorescent lamp
	Strong flash light (toward UV sensor)
Gamma ray and X ray sources	Diffraction analyzer
	Electron microscope
	X ray camera
	High voltage vacuum switch
	High voltage capacitor
	Radioactive isotope
Other sources producing ultraviolet rays, gamma rays, and X rays	

■ Firmly mounting of monitoring pipe

- (1) When the equipment is operated properly with the specified flame voltage output after all adjustments have been completed correctly, turn OFF the power to the equipment, remove the AUD300C, and weld the monitoring pipe firmly.
- (2) Mount the AUD300C on the monitoring pipe firmly and perform the final wiring completely.

■ Final inspection

To control the burner properly, perform at least one cycle operation of the equipment to check that all control actions correctly.

Chapter 5. TROUBLESHOOTING

! WARNING



Before removing or mounting the AUD300C, be sure to turn the power OFF. Failure to do so might cause electric shock.



Do not touch the AUD300C or the F-terminal or G-terminal of the AUR series immediately after the power to the AUR series has been turned OFF. The F-terminal and G-terminal are still electrically alive within 1min after the power has been turned OFF, causing an electric shock hazard.

! CAUTION



Only authorized personnel who have the technical skill about the combustion equipment and flame safeguard control must carry out the mounting, wiring, inspection, adjustment, and maintenance work.

● Tools and parts to be prepared

- Analog flame meter FSP136A100
- For details about replacement parts, refer to the section;
 - ➡ ● Maintenance parts and Optional parts (page 2).

● Trouble checking procedures

(1) Check the operating conditions.

Check item	Contents
Power voltage	<ul style="list-style-type: none"> • Check that the power switch is turned ON correctly. • Check for loose power terminal. • Check that the voltage is within the allowable range.
Wiring	<ul style="list-style-type: none"> • Check that the wiring is correct. • Check for faulty wiring. • Check the insulation for deterioration or damage.
Ambient temperature	<ul style="list-style-type: none"> • Check that the temperature is +100°C or less.
Ambient humidity	<ul style="list-style-type: none"> • Check that the ambient humidity is 90%RH or less. • Check that no dew condensation occurs inside the unit.

(2) Check the unit according to the flowchart.

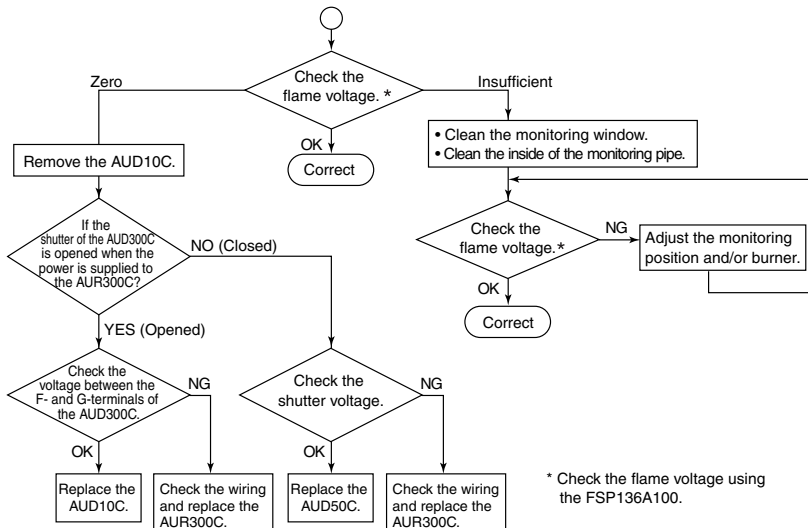

Chapter 6. MAINTENANCE AND INSPECTION

WARNING



Before removing or mounting the AUD300C, be sure to turn the power OFF. Failure to do so might cause electric shock.



Do not touch the AUD300C or the F-terminal or G-terminal of the AUR300C immediately after the power to the AUR300C has been turned OFF. The F-terminal and G-terminal are still electrically alive within 1min after the power has been turned OFF, causing an electric shock hazard.

CAUTION



Only authorized personnel who have the technical skill about the combustion equipment and flame safeguard control must carry out the mounting, wiring, inspection, adjustment, and maintenance work.



The service life of the tube unit AUD10C built-into the AUD300C is 3 years or 25,000 operation hours. To ensure the operational safety, replace the tube unit with a new one within this service life.

■ Periodic inspection

- (1) Turn OFF the power to the AUR series.
- (2) Clean the monitoring window and monitoring pipe periodically.
Remove the AUD300C from the monitoring pipe, and clean the inside of the monitoring pipe and/or the lens with a cloth rag.
- (3) To check the function of the tube unit AUD10C, perform the safety shut-off test periodically.
For details about safety shut-off test, refer to;
 -  user's manual for AUR300C, CP-SP-1142E.
 - user's manual for AUR350C, CP-SP-1175E.
 - user's manual for AUR450C, CP-SP-1264E.
- (4) Adjust the burner so that it is operated at its optimal operating level recommended by the burner manufacturer.

● Frequency of maintenance and inspection

Inspection contents	Inspection frequency
Contamination of monitoring window and monitoring pipe, or loose screw	Once a month or more
Safety shut-off test	Once a month or more
Measurement of flame voltage	Once a month or more
Pilot turn down test	Once a year or more

Handling Precautions

- If the burner shut-off operation may cause a serious accident, perform the inspection more frequently.
- If the burner manufacturer provides specific instructions about the maintenance and inspection, always strictly observe them.

■ Replacement of maintenance kit

⚠ CAUTION



The service life of the tube unit is a maximum of 3 years or 25,000 hours of operation. Similarly, the recommended life of the shutter unit is 3 years. To ensure operational safety, replace the maintenance kit within this service life.

The maintenance kit is composed of the AUD10C tube unit and the AUD50A shutter unit, and attached the O-ring etc. as consumables.

For details about replacement of maintenance kit, refer to;

👉 user's manual for the AUD60A2100/2110, CP-UM-5441E

■ Replacement of tube unit

⚠ CAUTION



The service life of the tube unit is a maximum of 3 years or 25,000 hours of operation. To ensure safety, replace it with a new one within this service life.

- (1) Turn OFF the power.
- (2) After 1min has elapsed, remove 4 cover mounting screws to detach the cover.
- (3) Remove 2 tube unit fixing screws on the rear of the tube unit.
- (4) Hold the rear of the tube unit and gently raise it upward to remove it.
- (5) Insert the top of a new tube unit into the round hole in the upper portion of the shutter unit and push-down the rear to mount it.
- (6) Tighten 2 tube unit fixing screws.
- (7) Make sure that the O-ring is not disengaged from the flange unit.
- (8) Secure the cover with 4 cover mounting screws.

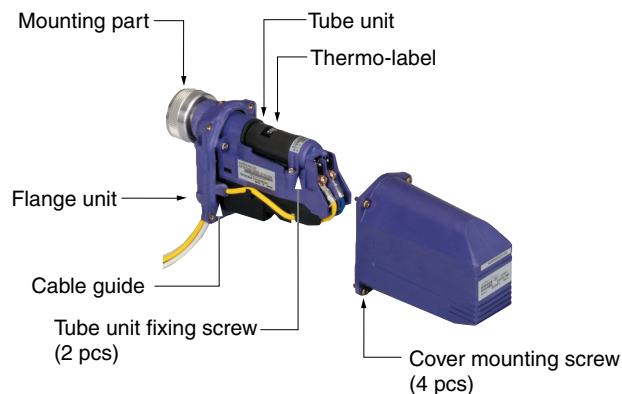

ⓘ Handling Precautions

- The tube unit has specific polarities. Make these polarities matched with the polarity indication label F, G at the upper portion of the shutter unit and mount it correctly.
- When transporting or storing the tube unit, always put it in the specially designed packing box.

- The tube unit is made of glass. Handle it carefully so as not to give an impact to the unit.
- If the thermo-label provided on the AUD10C has turned black (no longer white), there is the possibility that its temperature has exceeded the allowable operating temperature range. When the ambient temperature around the advanced UV sensor in operation is highly excessive, cool the unit using the air purging. The thermo-label should be regarded as a reference only. Always confirm the correct ambient temperature with a thermometer.
- When mounting the cover, mount the O-ring of the flange unit firmly. Failure to do so may cause the sealing ability to lower.
- Tighten the terminal screws and mounting screws with a tightening torque of 0.7N·m.

■ Replacement of shutter unit

CAUTION



Replace the shutter unit AUD50A with a new one at a reference replacement interval of 3 years.

- (1) Turn OFF the power.
- (2) Remove 4 cover mounting screws to detach the cover.
- (3) Remove 4 terminal screws (white lead wire x 2, blue lead wire x 1, yellow lead wire x 1) to disconnect the lead wires from the shutter unit.
- (4) Remove 2 shutter unit fixing screws.
- (5) Separate the flange unit from the shutter unit with they opened upward to remove it. At this time, pay special attention so that the lead wires are not disconnected from the cable guide of the flange unit.
- (6) Remove the orifice sheet from the flange unit.
- (7) Remove the tube unit from the shutter unit. For details, refer to;
 previous section, ■ Replacement of tube unit.
- (8) Provide a new orifice sheet and push it to the lens in the flange unit.
- (9) Secure a new shutter unit to the flange unit.

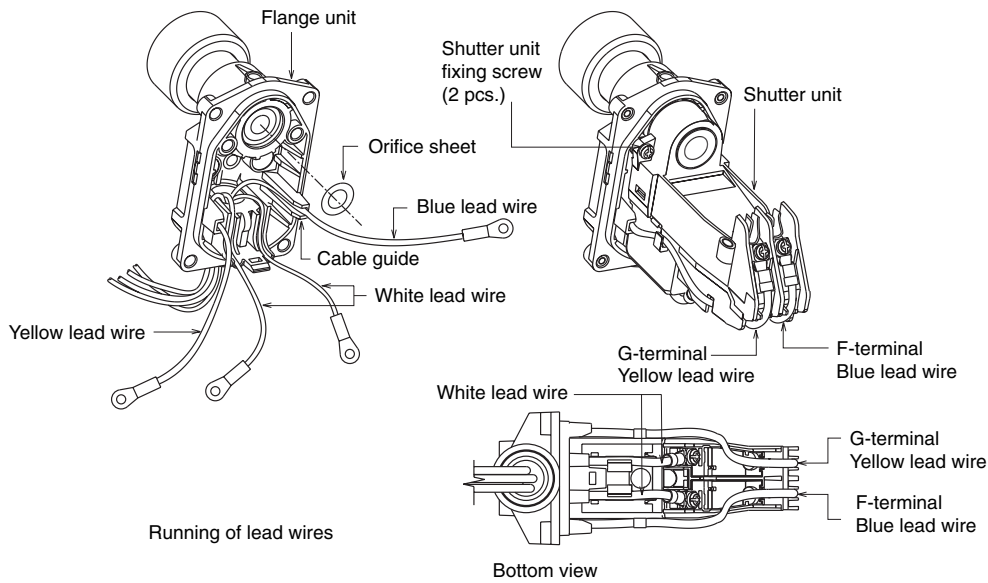

! Handling Precautions

- If the lead wires are disengaged from the grooves on the cable guide of the flange unit, put lead wires in relevant slits on the shutter unit and mount the tube unit on the flange unit with the lower white lead wires fit-into the grooves on the cable guide.

(10) Connect the lead wires to the terminals on the shutter unit correctly.

! Handling Precautions

- Connect the blue lead wire to the F-terminal and yellow lead wire to the G-terminal. Connect the signal wires so that they are matched with the polarity indication label F, G on the shutter unit.

(11) Mount the tube unit.

(12) Subsequent procedures are the same as those after step (6) stated in the previous section, ■ Replacement of tube unit.

! Handling Precautions

- Tighten the terminal screws and mounting screws with a tightening torque of 0.7N·m.

Chapter 7. SPECIFICATION

■ Specification

Item	Description
Applicable flames*	City gas, Natural gas, Propane gas, Kerosene, Heavy oil, Coke oven gas, Hydrogen, Chlorine, Ammonia, Naphtha, Ethylene, etc.
Shutter voltage	Approx. 24Vdc (supplied from AUR series)
Self-checking cycle	Approx. 1 to 2 times/s
Insulation resistance	Between flange unit mounting nut and F-terminal (or blue lead wire), between flange unit mounting nut and G-terminal (or yellow lead wire), between flange unit mounting nut and S1-terminal (or white lead wire), between flange unit mounting nut and S2-terminal (or white lead wire): 50MΩ min. by 500Vdc megger at the above each location. (The AUD10 tube unit must be dismantled.)
Dielectric strength	Between flange unit mounting nut and F-terminal (or blue lead wire), between flange unit mounting nut and G-terminal (or yellow lead wire), between flange unit mounting nut and S1-terminal (or white lead wire), between flange unit mounting nut and S2-terminal (or white lead wire): 1500Vac for 1min or 1800Vac for 1s at the above each location. (The AUD10 tube unit must be dismantled.)
Ambient temperature	-20 to +100°C
Ambient storage temperature	-20 to +70°C
Ambient storage humidity	90%RH at 40°C max. (no condensation allowed)
Vibration resistance	4.9m/s ² max., 10 to 55Hz for 2 hours each in X, Y and Z directions
Impact resistance	300m/s ² in vertical and horizontal directions
Pressure resistance for flange	350kPa
Protection	IP66 (except a conduit tube connection port)
Mounting posture	-45 to +90° (in vertical direction)
Mounting	G1 (at the mounting section for monitoring pipe)
Lead wires	AWG18 heat resistant silicone cables, with 2.4m color lead wires (4 pcs)
Electric wire pipe mounting conduit	1/2-14NPSM
Flame signal wire requirements and extension distance	Requirements: 600V vinyl insulation wires, IV wires with 2.0mm ² , 200m max.
Materials	Main body: Heat resistant resin (PPE) Mounting nut: Aluminum
Main body color	Purple (equivalent to DIC257)
Mass	Approx. 630g
Tube unit effective service life	Tube unit to be replaced after 25,000 hours of use or the specified lifespan (3 years) marked on Tube unit
Applicable standards	UL certificated: UL file No.MH27717

* Ultraviolet ray quantity differs according to the type of fuel. Also, the combustion quantity of burner, type of equipment or installation conditions will give influence.

■ Dimensions

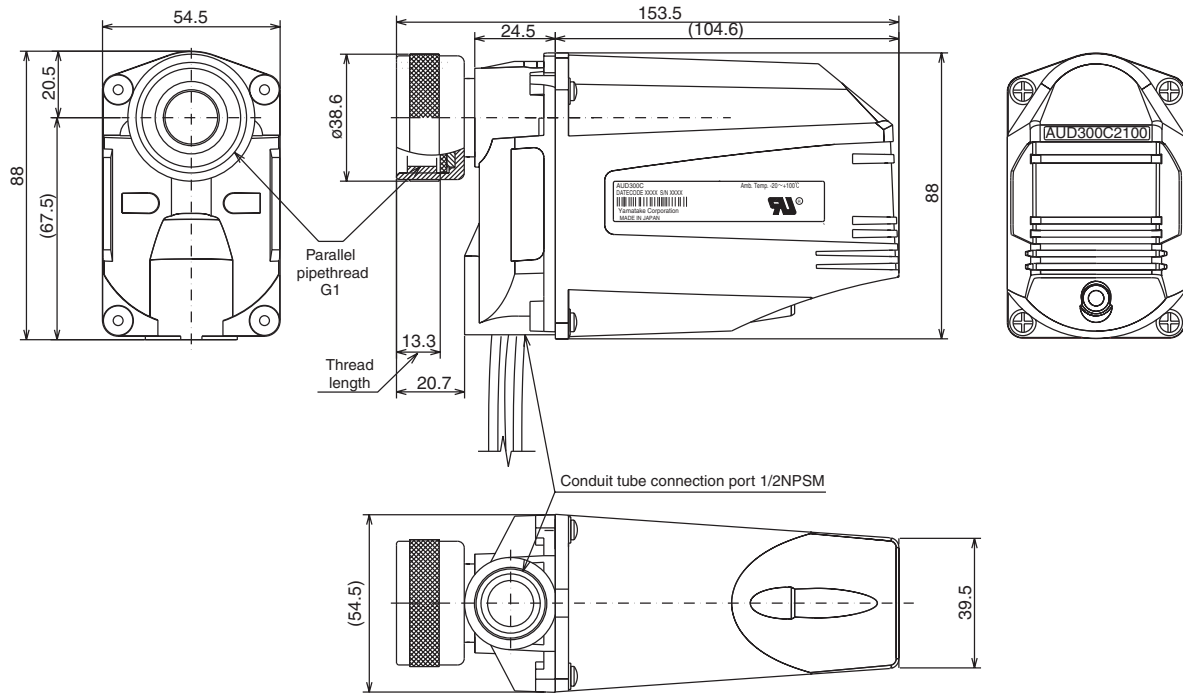

azbil

Yamatake Corporation
Advanced Automation Company

1-12-2 Kawana, Fujisawa
Kanagawa 251-8522 Japan

URL: <http://www.azbil.com>

Printed on recycled paper. (07)

Specifications are subject to change without notice.

Printed in Japan.
1st Edition: Issued in Aug. 2004 (E)
2nd Edition: Issued in May 2007 (M)