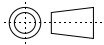

SP. NO.	Azbil Corporation				製品仕様書 SPECIFICATIONS				
		<p>1. Summary</p> <p>This product is a sub-base for Dynamic Self-check Burner Controller, the AUR4*0.</p> <p>2. Ambient Temperature</p> <p>-20 °C ~+60°C</p> <p>3. Dielectric Strength</p> <p>50/60Hz, AC1500V for 1 min. or AC1800V for 1 sec. without breakdown, between the enclosure and each terminal. To prevent any burnout on the AUR, this check is carried out without the AUR4*0.</p> <p>4. Insulation resistance:</p> <p>50MΩ or more (with a DC500V megger) between the enclosure and each terminal. To prevent any burnout on the AUR, this check is carried out without the AUR4*0.</p> <p>5. Mass</p> <p>Approximately 185 g</p> <p>6. Recommended wire size</p> <p>AWG14~AWG18</p> <p>7. Approvals</p> <p>UL File No. MH27717</p>							
					作成 DR. M. Futamura '08-09-19		尺度 SCALE ~	記入のない公差 TOL.UNLESS NOTED ~	
					検図 CHK. S. Ishii '08-09-19	形 番 MODEL	Q 2 4 1 A 1 0 4		
3	00				認可 APPD T. Yamada '08-09-19	名 称 NAME	S u b - b a s e		
2	00				日付 DATE '08-09-19	図 番 NO.	AD 1 3 9 0 0 E	改番 REV 00	1 / 3
頁	改番	改 番 REV.	来 歴 RECORD	日 付 DATE	担 当 BY	検 閲 APPD.			

SP.NO.

# Azbil Corporation

## 製品仕様書 SPECIFICATIONS

### 8. Notice

- (1) Do not install this unit in the following places:
  - In the presence of acids or other corrosive chemicals or gases (ammonia, sulfur, chlorine, ethylene compounds, etc.).
  - Where it is exposed to water drops or damp atmosphere.
  - Where it is exposed to high temperatures.
  - Where vibration continues for an extended period of time.
- (2) Before wiring the Q241A104, be sure to turn the power OFF. Touching any terminal accidentally may cause an electric shock or damage.
- (3) After the wiring is complete, check that it is correct. Incorrect wiring may cause damage or malfunction. Notice especially that the flame sensor has specific polarity.
- (4) Wire the signal cable of the flame detector in an independent conduit. Do not bundle it with multiple signal lines or power lines.
- (5) This unit must be grounded with a resistance of less than 100Ω, as described in the electric facility technical standards. The ground line must be connected to the burner chassis.
- (6) Be sure that the power supply wires (power wires) and high voltage wires of the ignition transformer are separately wired from the flame detector wires and reset input lead wires. Not separating them might cause faulty operation.

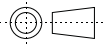
作成 DR. M. Futamura '08-09-19		尺度 SCALE ~	記入のない公差 TOL.UNLESS NOTED ~
検図 CHK. S. Ishii '08-09-19	形 番 MODEL	Q 2 4 1 A 1 0 4	
認可 APPD T. Yamada '08-09-19	名 称 NAME	S u b - b a s e	
日付 DATE '08-09-19	図 番 NO.	AD 1 3 9 0 0 E	改番 REV 00

頁	改番	改番 REV.	来歴 RECORD	日付 DATE	担当 BY	検閲 APPD.
---	----	------------	--------------	------------	----------	-------------

SP. No.

**Azbil Corporation**

製品仕様書  
SPECIFICATIONS

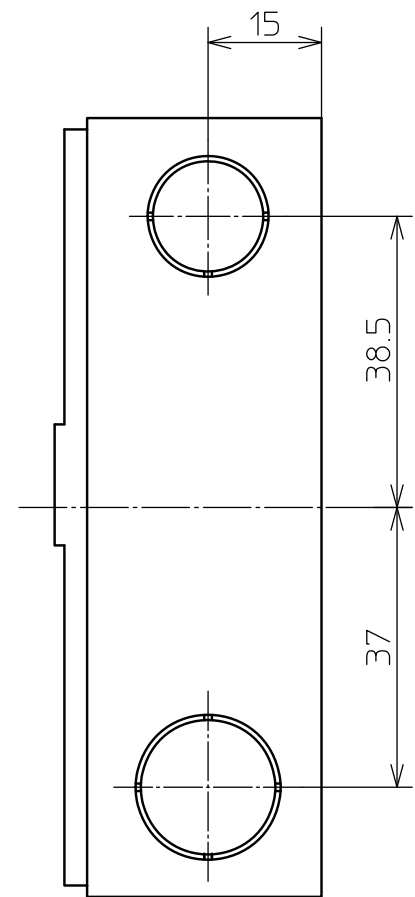
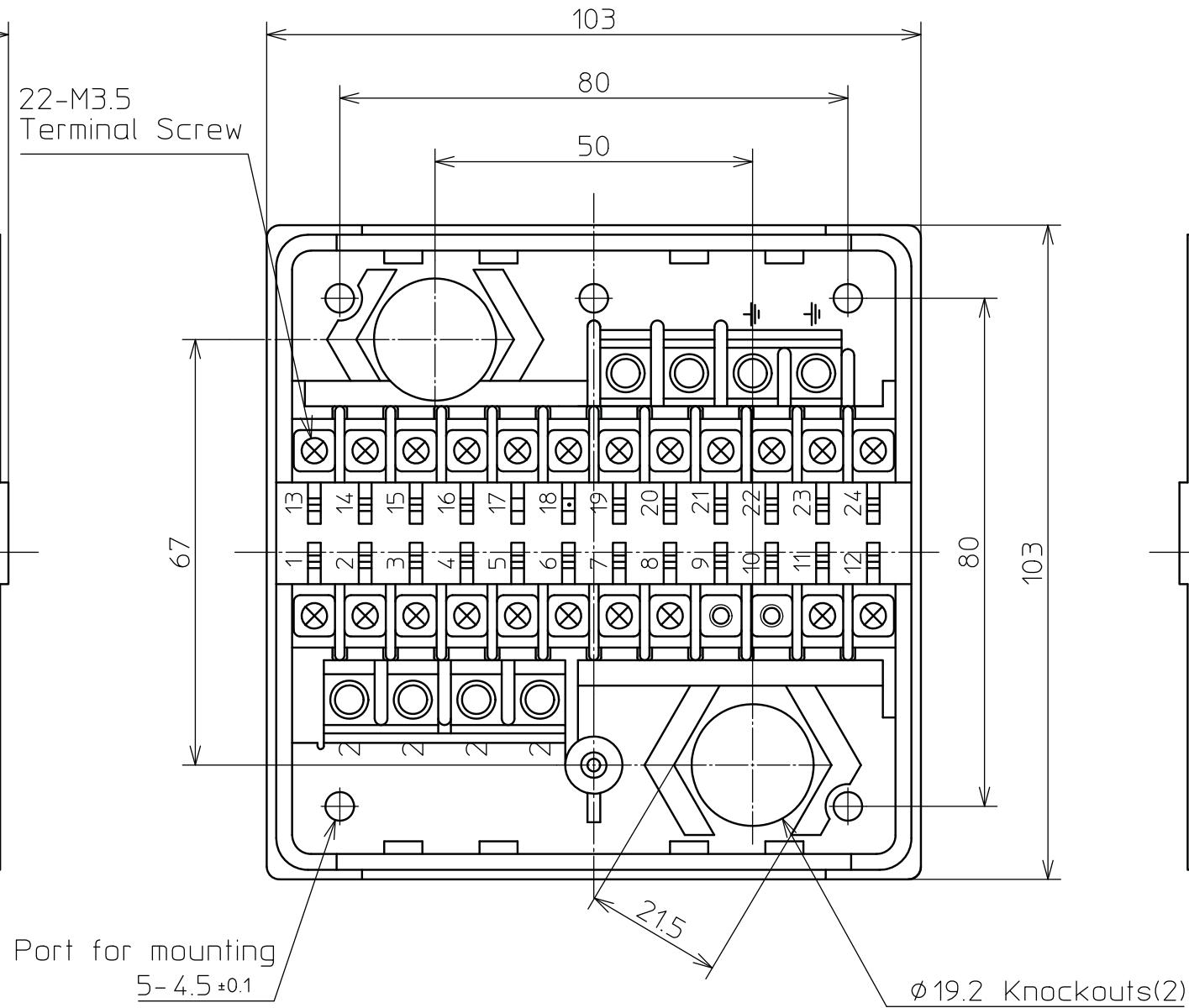
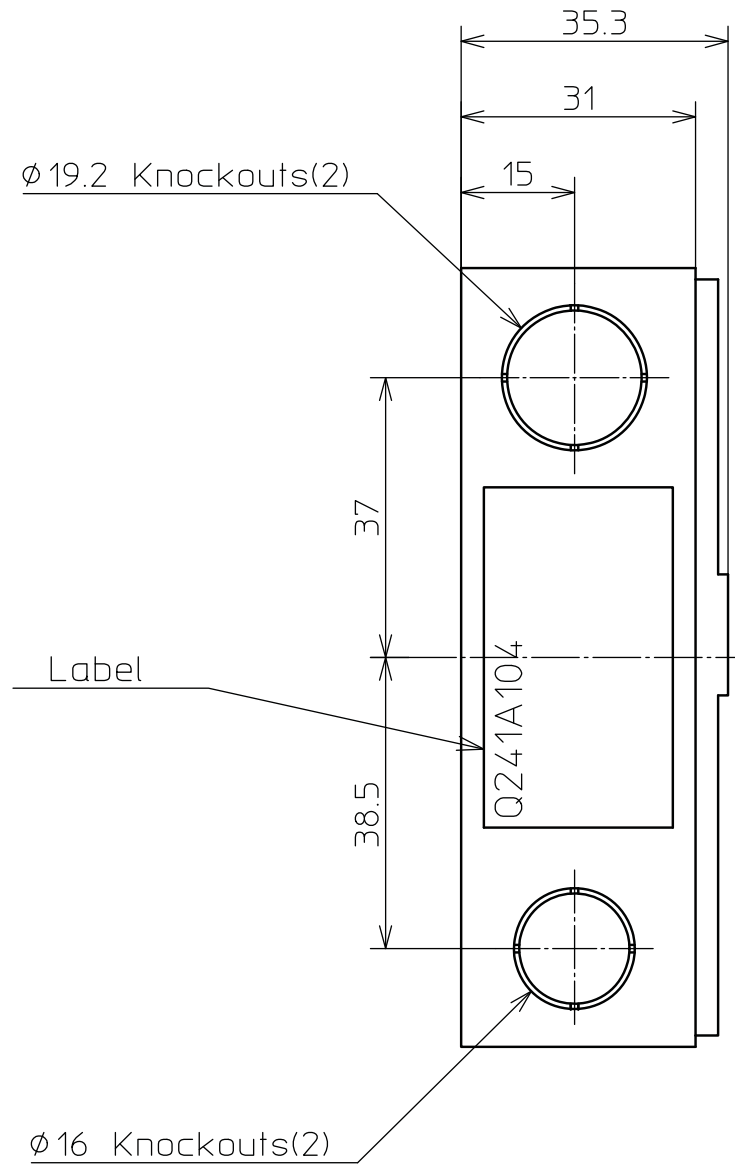

Detail at a terminal part

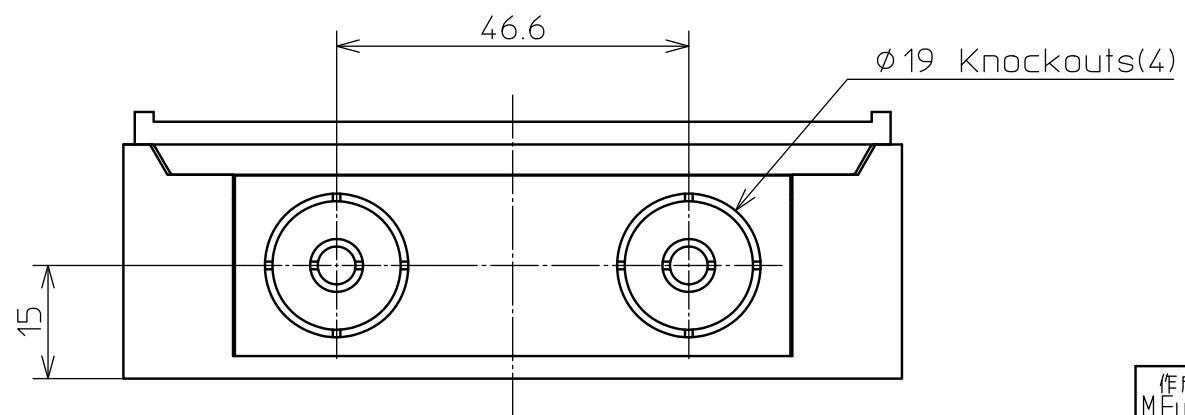
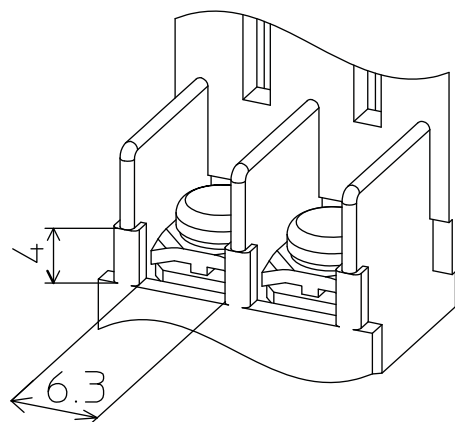

Note1. Accessory M3.5 Free Terminal Screw (2)

作成DR. M.Futamura '08-09-19	検図CHK. S.Ishii '08-09-19	認可APPD T.Yamada '08-09-19	日付DATE '08-09-19	改番REV. 00	改番REV. 3/3
尺度SCALE 1:1 記入のない公差 TOL. UNLESS NOTED		形番 MODEL Q241A104	名称 NAME Sub-base	日付DATE '08-09-19	図番 NO. AD13900E

SP. NO.	Azbil Corporation		製品仕様書 SPECIFICATIONS			
	<b>Terms and Conditions</b>					
	<p>We would like to express our appreciation for your purchase and use of azbil products.          You are required to acknowledge and agree upon the following terms and conditions for your purchase of azbil products (field instruments, control valves, and control products), unless otherwise stated in any separate document, including, without limitation, estimation sheets, written agreements, catalogs, specifications and instruction manuals.</p>					
	<p><b>1 Warranty period and warranty scope</b></p>					
	<p><b>1.1 Warranty period</b>          Azbil products shall be warranted for one (1) year from the date of your purchase of the said products or the delivery of the said products to a place designated by you.</p>					
	<p><b>1.2 Warranty scope</b>          In the event that azbil product has any failure attributable to azbil during the aforementioned warranty period, azbil shall, without charge, deliver a replacement for the said product to the place where you purchased, or repair the said product and deliver it to the aforementioned place.          Notwithstanding the foregoing, any failure falling under one of the following shall not be covered under this warranty:</p>					
	<p>(1) Failure caused by your improper use of azbil product          (noncompliance with conditions, environment of use, precautions, etc. set forth in catalogs, specifications, instruction manuals, etc.);</p>					
	<p>(2) Failure caused for other reasons than azbil product;</p>					
	<p>(3) Failure caused by any modification or repair made by any person other than azbil or azbil's subcontractors;</p>					
	<p>(4) Failure caused by your use of azbil product in a manner not conforming to the intended usage of that product;</p>					
	<p>(5) Failure that the state-of-the-art at the time of azbil's shipment did not allow azbil to predict; or</p>					
	<p>(6) Failure that arose from any reason not attributable to azbil, including, without limitation, acts of God, disasters, and actions taken by a third party.</p>					
	<p>Please note that the term "warranty" as used herein refers to equipment-only-warranty, and azbil shall not be liable for any damages, including direct, indirect, special, incidental or consequential damages in connection with or arising out of azbil products.</p>					
	<p><b>2 Ascertainment of suitability</b></p>					
	<p>You are required to ascertain the suitability of azbil product in case of your use of the same with your machinery, equipment, etc. (hereinafter referred to as "Equipment") on your own responsibility, taking the following matters into consideration:</p>					
	<p>(1) Regulations and standards or laws that your Equipment is to comply with.</p>					
	<p>(2) Examples of application described in any documents provided by azbil are for your reference purpose only, and you are required to check the functions and safety of your Equipment prior to your use.</p>					
	<p>(3) Measures to be taken to secure the required level of the reliability and safety of your Equipment in your use          Although azbil is constantly making efforts to improve the quality and reliability of azbil products, there exists a possibility that parts and machinery may break down.          You are required to provide your Equipment with fool-proof design, fail-safe design, anti-flame propagation design, safety design, or the like so that the said Equipment may satisfy the level of the reliability and safety required in your use, whereby preventing any occurrence of physical injuries, fires, significant damage, and so forth.</p>					
	<p><b>3 Precautions and restrictions on application</b></p>					
	<p>Azbil products other than those explicitly specified as applicable (e.g. azbil Limit Switch For Nuclear Energy) shall not be used in a nuclear energy controlled area (radiation controlled area).          Any azbil products shall not be used for/with medical equipment.          In addition,          you are required to conduct a consultation with our sales representative and understand detail specifications, cautions for operation, and so forth by reference to catalogs, specifications, instruction manual, etc. in case that you intend to use azbil product for any purposes specified in (1) through (6) below.          Moreover, you are required to provide your Equipment with fool-proof design, fail-safe design, anti-flame propagation design and other designs of protection/safety circuit on your own responsibility to ensure the reliability and safety, whereby preventing problems caused by failure or nonconformity.</p>					
	<p>(1) For use under such conditions or in such environments as not stated in technical documents, including catalogs, specification, and instruction manuals</p>					
	<p>(2) For use of specific purposes, such as:</p>					
	<p>* Nuclear energy/radiation related facilities          [For use outside nuclear energy controlled areas]          [For use of azbil Limit Switch For Nuclear Energy]</p>					
	<p>* Machinery or equipment for space/sea bottom</p>					
	<p>* Transportation equipment          [Railway, aircraft, vessels, vehicle equipment, etc.]</p>					
	<p>* Antidisaster/crime-prevention equipment</p>					
	<p>* Burning appliances</p>					
	<p>* Electrothermal equipment</p>					
	<p>* Amusement facilities</p>					
頁	改番	改番	来歴	日付	担当	検閲
		REV.	RECORD	DATE	BY	APPD.

SP.NO.		Azbil Corporation		製品仕様書 SPECIFICATIONS		
		<p>(3) Supply systems such as electricity/gas/water supply systems, large-scale communication systems, and traffic/air traffic control systems requiring high reliability</p> <p>(4) Facilities that are to comply with regulations of governmental/public agencies or specific industries</p> <p>(5) Machinery or equipment that may affect human lives, human bodies or properties</p> <p>(6) Other machinery or equipment equivalent to those set forth in items (1) to (5) above which require high reliability and safety</p> <p><b>4 Precautions against long-term use</b></p> <p>Use of azbil products, including switches, which contain electronic components, over a prolonged period may degrade insulation or increase contact-resistance and may result in heat generation or any other similar problem causing such product or switch to develop safety hazards such as smoking, ignition, and electrification.</p> <p>Although acceleration of the above situation varies depending on the conditions or environment of use of the products, you are required not to use any azbil products for a period exceeding ten (10) years unless otherwise stated in specifications or instruction manuals.</p> <p><b>5 Recommendation for renewal</b></p> <p>Mechanical components, such as relays and switches, used for azbil products will reach the end of their life due to wear by repetitious open/close operations.</p> <p>In addition, electronic components such as electrolytic capacitors will reach the end of their life due to aged deterioration based on the conditions or environment in which such electronic components are used.</p> <p>Although acceleration of the above situation varies depending on the conditions or environment of use, the number of open/close operations of relays, etc. as prescribed in specifications or instruction manuals, or depending on the design margin of your machine or equipment, you are required to renew any azbil products every 5 to 10 years unless otherwise specified in specifications or instruction manuals.</p> <p>Field instruments (sensors such as pressure/flow/level sensors, regulating valves, etc.) will reach the end of their life due to aged deterioration of parts.</p> <p>For those parts that will reach the end of their life due to aged deterioration, recommended replacement cycles are prescribed. You are required to replace parts based on such recommended replacement cycles.</p> <p><b>6 Other precautions</b></p> <p>Prior to your use of azbil products, you are required to understand and comply with specifications (e.g., conditions and environment of use), precautions, warnings/cautions/notices as set forth in the technical documents prepared for individual azbil products, such as catalogs, specifications, and instruction manuals to ensure the quality, reliability, and safety of those products.</p> <p><b>7 Changes to specifications</b></p> <p>Please note that the descriptions contained in any documents provided by azbil are subject to change without notice for improvement or for any other reason.</p> <p>For inquiries or information on specifications as you may need to check, please contact our branch offices or sales offices, or your local sales agents.</p> <p><b>8 Discontinuance of the supply of products/parts</b></p> <p>Please note that the production of any azbil product may be discontinued without notice.</p> <p>For repairable products, we will, in principle, undertake repairs for five (5) years after the discontinuance of those products. In some cases, however, we cannot undertake such repairs for reasons, such as the absence of repair parts.</p> <p>For field instruments, we may not be able to undertake parts replacement for similar reasons.</p> <p><b>9 Scope of services</b></p> <p>Prices of azbil products do not include any charges for services such as engineer dispatch service. Accordingly, a separate fee will be charged in any of the following cases:</p> <p>(1) Installation, adjustment, guidance, and attendance at a test run</p> <p>(2) Maintenance, inspection, adjustment, and repair</p> <p>(3) Technical guidance and technical education</p> <p>(4) Special test or special inspection of a product under the conditions specified by you</p> <p>Please note that we cannot provide any services as set forth above in a nuclear energy controlled area (radiation controlled area) or at a place where the level of exposure to radiation is equivalent to that in a nuclear energy controlled area.</p>				
頁	改番	改番	来歴	日付	担当	検閲
	REV.		RECORD	DATE	BY	APPD.