

# AUD300C1000 Series Advanced Ultraviolet Flame Detector

The AUD300C1000 series Advanced Ultraviolet Flame Detector is designed to detect ultraviolet radiation from an oil or gas burner flame, for use with both batch and continuous operation.

The AUD300C is used in combination with a dedicated burner controller. By means of the built-in shutter, any malfunction of the UV flame detector or burner controller is detected by the continuous self-checking (Dynamic Self-Check) function, ensuring highly reliable combustion safety control.

## ■ Features

- Replacement and maintenance work is easy with the AUD Maintenance Kit (AUD60A1000), which includes the tube and shutter units.
- As a flame detector, the AUD300C is compact and light weight, thus, facilitating installation.
- Excellent environmental specifications. Ambient temperature 100°C, IP66, vertical mounting possible and wiring distance 200m max.



## ■ Specifications

Item	Description
Applicable types of flames *1	City gas, Natural gas, Propane gas, Kerosene, Heavy oil, Coke oven gas, Hydrogen, Chlorine, Ammonia, Naphtha, Ethylene, etc.
Shutter voltage	Approx. 24Vdc (supplied from Burner Controller)
Self-checking cycle	Approx. 75 cycles/ min.
Insulation resistance	Between flange unit mounting conduit and F-terminal (or blue lead wire), between flange unit mounting conduit and G-terminal (or yellow lead wire), between flange unit mounting conduit and S1-terminal (or white lead wire), between flange unit mounting conduit and S2-terminal (or white lead wire): 50MΩ min. by 500Vdc megger at the above each location. (However, the tube unit must be removed.)
Dielectric strength	Between flange unit mounting conduit and F-terminal (or blue lead wire), between flange unit mounting conduit and G-terminal (or yellow lead wire), between flange unit mounting conduit and S1-terminal (or white lead wire), between flange unit mounting conduit and S2-terminal (or white lead wire): 1500Vac for 1 min or 1800Vac for 1 sec at the above each location. (However, the tube unit must be removed.)
Ambient temperature	-20 to +100°C During flame detection, the maximum allowable ambient temperature is +120°C.
Ambient storage temperature	-20 to +70°C
Ambient humidity	90%RH at 40°C max. (without condensation)
Impact resistance	300m/s <sup>2</sup> in vertical and horizontal directions
Vibration resistance	4.9m/s <sup>2</sup> max., 10 to 55Hz for 2 hours each in X, Y and Z directions
Pressure resistance for flange	350kPa
Protection	IP66 (except a conduit tube connection port)
Mounting posture	-45 to +90° (in vertical direction)
Flame signal wire requirements and extension distance	Requirements: 600V vinyl insulation wires, IV wires with 2.0 mm <sup>2</sup> , Max. 200 m
Expiration date of tube unit and shutter unit	3 years
Standards compliance *2	CE, UL, CSA

\*1 For applications using coke oven gas, hydrogen, chlorine, ammonia, naphtha, ethylene, etc., in which the burner structure may impose restrictions on the mounting of the flame detector, it is necessary to check that flame monitoring is reliable.

\*2 Standards approvals are valid only for a combination of AUR450C, AUD300C, and Q241A104

Item	Description
Mounting	G1 (at the mounting section for sighting pipe)
Lead wires	AWG18 heat resistant silicone cables, with 2.4m color lead wires
Electric wire pipe mounting conduit	1/2-14NPSM
Materials	Main body: Heat resistant resin Mounting section: Aluminum
Main body color	Purple (equivalent to DIC257)
Weight	Approx. 630g

## ■ Model No.

Model No.	Lens type	Additional features	Special treatment
AUD300C1000	Standard	None	None
AUD300C100D		Inspection certificate provided	None
AUD300C100T		None	Tropicalization
AUD300C100DT		Inspection certificate provided	Tropicalization
AUD300C1100	Condenser	None	None
AUD300C110D		Inspection certificate provided	None
AUD300C110T		None	Tropicalization
AUD300C110DT		Inspection certificate provided	Tropicalization

## ■ Combined burner controller

Model No.	Description
RX-R40, RX-R44, RX-R46	Burner Control Module
AUR300C, AUR350C	Advanced Ultraviolet Burner Controller
AUR450C	Dynamic Self-Checking Burner Controller

## ■ Maintenance/optional parts

Model No.	Description
AUD60A1000	AUD Maintenance kit (includes shutter and tube units)
81409780-001	Bushing 1 x 3/4

## ■ Wiring

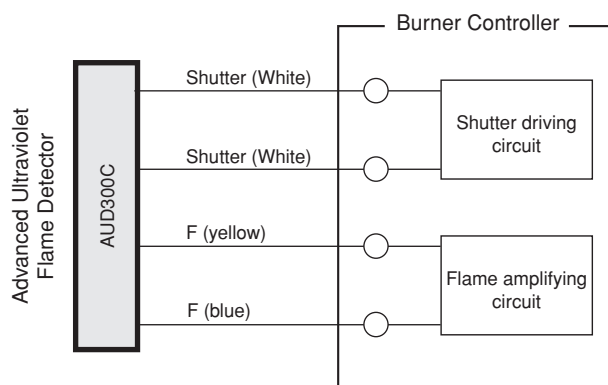

## ⚠ Handling Precautions

- The flame detector has polarity. Correctly connect the wiring to the terminals indicated on the device (F-terminal and G-terminal). The attached blue cable is for the F-terminal, and the yellow cable is for the G-terminal.

## ■ Dimensions

### ● Body

(Unit: mm)

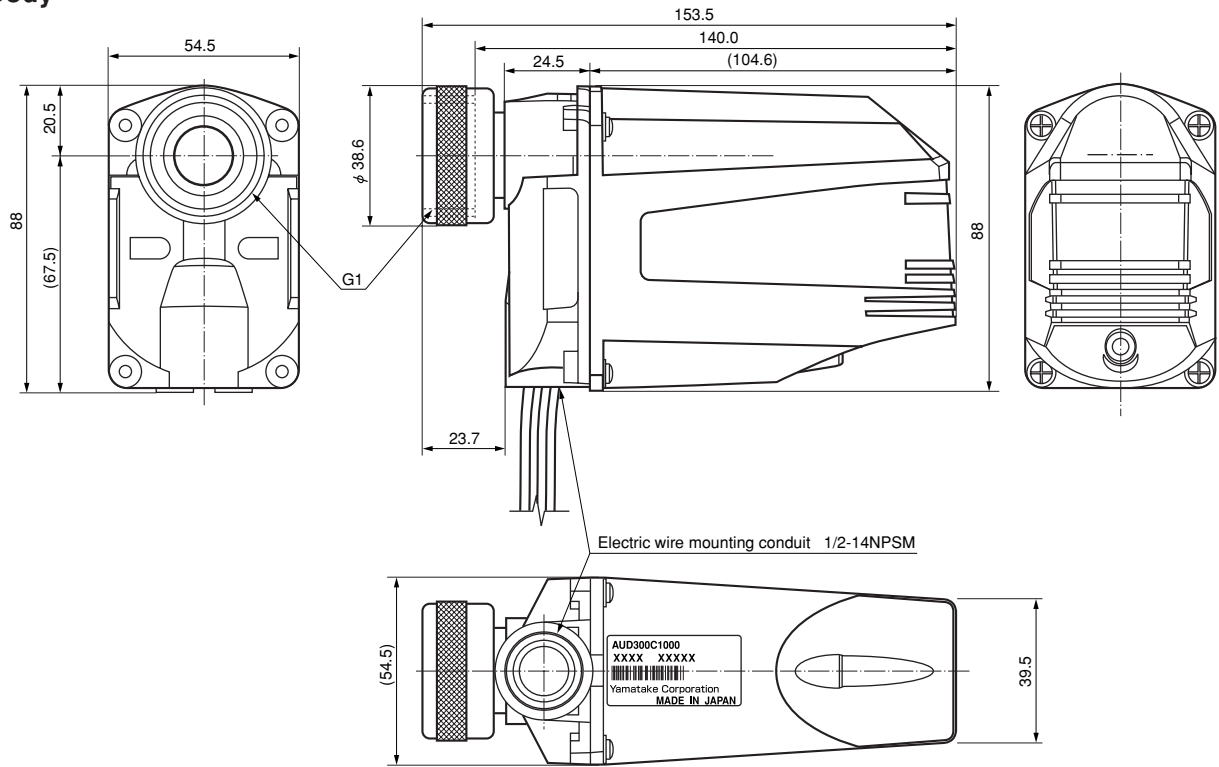

### ● Bushing

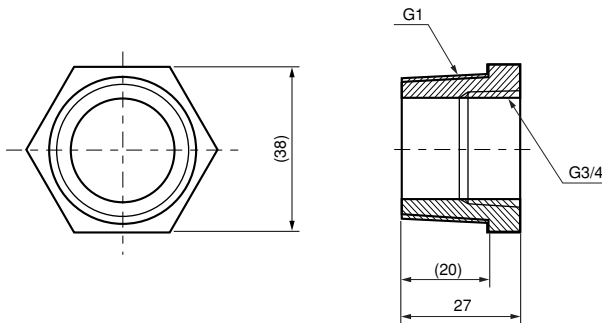

## Cautions

- (1) The AUD300C Advanced Ultraviolet Flame Detector has an important role for safety in monitoring the burner flame. Please adhere the procedures for safe usage stated in the user's manual.
- (2) Do not mount the flame detector in the following locations:
  - Locations near special chemicals or in atmospheres containing ammonia, sulfur, chlorine, ethylene compounds, acid, or any other corrosive gases.
  - Locations subject to continuous vibration
- (3) When used in atmospheres where an UV ray source exists other than the flame, take countermeasures so that no other UV ray other than that of burner is detected.
- (4) Before wiring, be sure to turn the power off. Touching terminals by mistake while the power is on might result in electric shock or malfunction.
- (5) The flame sensor has polarity. Correctly connect the wiring to the terminals indicated on the device (F-terminal and G-terminal). The attached blue cable is F-terminal, and yellow cable is G-terminal.
- (6) Use a dedicated packing case when transporting or storing this detector.
- (7) Do not bundle the power leads together with the flame sensor signal lead wires, nor place them in the same conduit. Use independent cables.
- (8) Make sure that the ignition transformer high-voltage cables are properly connected in order to prevent faulty contacts. If there is a poor contact, radio frequency waves may be generated and this could cause errors from radio interference. Install the ignition transformer directly onto a metal portion electrically connected to the burner.
- (9) The flame sensor of the AUD 300C is made of a glass tube. Do not subject it to vibration or shock. In particular, when transporting combustion equipment, be sure to pack the flame detector in a dedicated packing case.

Please read the "Terms and Conditions" from the following URL before ordering or use:

<http://www.azbil.com/products/bi/order.html>

*Specifications are subject to change without notice.*



## Yamatake Corporation Advanced Automation Company

1-12-2 Kawana, Fujisawa  
Kanagawa 251-8522 Japan  
URL: <http://www.azbil.com/>

1st Edition: Issued in Aug. 2002  
7th Edition: Issued in Oct. 2011

*No part of this publication may be reproduced or duplicated  
without the prior written permission of Yamatake Corporation.*