

Model J-APN11

Multifunction Pulse-to-Pneumatic Converter

OVERVIEW

The Multifunction Pulse-to-Pneumatic Converter receives an up/down pulse signal to drive a 4-phase pulse motor and output a 20 to 100 kPa {0.2 to 1.0 kgf/m²} pneumatic signal by a flapper nozzle mechanism and a 4 to 20 mA DC feedback signal. If a power failure occurs, a worm gear mechanism mechanically retains the pneumatic signal at its position at time of power failure. (Note that the air supply must be normal for this function to operate.)

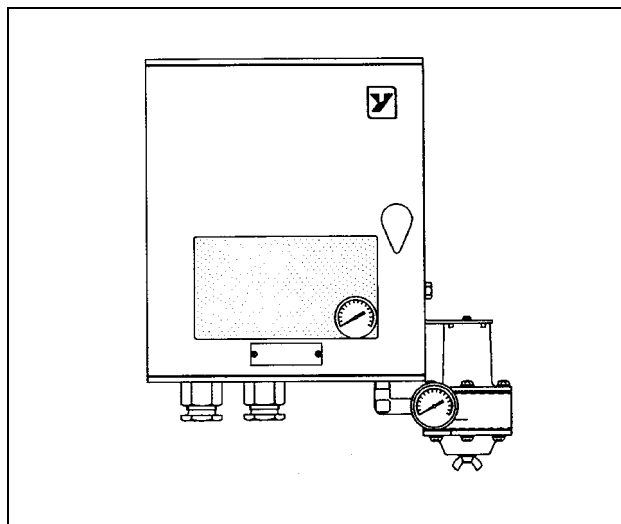

SPECIFICATIONS

Input Section

Up/down pulse signal

Pulse width:

The output will keep changing as long as an ON signal is input as an up or down pulse signal. The output speed depends on the response speed switching signal and its configured speed.

Pulse train:

Output changes from 0% to 100%FS with 1000 pulses of input.

Up/down signal

Contact input: Contact rating

Dry contact----30 V DC, 30 mA DC or more

Open collector-Vce30 V or more, Ic 30 mA DC or more

Leak current --- 2 mA DC max.

Pulse train:

Maximum response frequency: 150 pulses/sec

Maximum pulse width: 3.3 ms (at 150 pulses/sec)

Minimum pulse width: 2.5 ms

Full scale pulse count

1,000 pulses (pulse train input)

Pulse width

Minimum response pulse width of 8 ms

Output current minimum response time of 15ms (at maximum response speed)

Response speed switching signal

(Effective only with pulse width input):

Contact input: Contact rating

Dry contact --- 30 V DC, 30 mA DC or more

Open collector --- Vce30 V or more, Ic 30mA DC or more

Leak current --- 2mA DC max.

High speed at signal ON --- 7 to 30 sec./FS variable

Low speed at signal OFF --- 30 to 50 sec./FS variable

Output section

Pneumatic signal

20 to 100 kPa (adjustable in units of psi, bar, and kgf/cm²)

Current signal

4 to 20 mA DC or 20 to 4 mA DC

Signal power supply

24 V DC \pm 15% (when external power supply is provided for P/I unit)

Load

Max. 480 Ω at 24 V DC (4 to 20 mA DC output)

Limit contact signal

Detection by micro switch (NO or NC)

Select Yes or No for output contact signal.

When "Yes" is selected, cut off input pulse at the limit value using an external sequence circuit (to prevent transmitter chattering).

When "No" is selected, cut off the input pulse at the limit value using an internal circuit.

Limit value:

High limit: 103 \pm 1%FS fixed *1

Low limit: -3 \pm 1%FS fixed *1

*1 Please contact Yamatake if operation outside the range is desired.

Contact rating:

120 V AC, 0.1 A DC, resistance load

125 V DC, 0.1 A DC, resistance load

Mechanical stopper

This function mechanically cuts off the output when the input pulse exceeds the set value.

Stopper position:

High limit: 105 \pm 1%FS fixed *1

Low limit: -5 \pm 1%FS fixed *1

Output pneumatic pressure signal monitor

Up to 2 points (M1, M2); NO/NC

Setting range: 20 to 100kPa {0.2 to 1 kgf/cm²}

Standard setting:

1-point monitor

10 \pm 1%FS when M1 is set for low limit

90 \pm 1%FS when M1 is set for high limit

2-point monitor:

M1 90 \pm 1%FS

M2 10 \pm 1%FS

Contact rating

120 V AC, 0.1 A DC, resistance load

125 V DC, 0.1 A DC, resistance load

Pneumatic pressure down monitor

Pneumatic pressure loss: NO/NC

Setting range

110 to 120 kPa {1.1 to 1.2 kgf/cm²}

(Factory setting: 110 kPa {1.1 kgf/cm²})

Contact rating

120 V AC, 0.1 A DC, resistance load

125 V DC, 0.1 A DC, resistance load

Power supply down monitor

Power supply loss: NO/NC

Contact rating

120 V AC, 0.1 A DC, resistance load

125 V DC, 0.1 A DC, resistance load

Manual operation unit (Option)

Pneumatic pressure output can be set manually.

Balance and bumpless switching between Auto and

Manual for pneumatic pressure output

This option cannot be selected when 2 output pneumatic pressure signal monitor points are selected.

PERFORMANCE**Accuracy****Pulse train**Pulse/pneumatic pressure --- $\pm 2.0\%$ FSPneumatic pressure signal/current signal --- $\pm 0.5\%$ FS**Pulse width**Pneumatic pressure signal/current signal --- $\pm 0.5\%$ FS**Additional accuracy**

Influence of ambient temperature changes

Pneumatic pressure signal --- $\pm 0.5\%$ FS / 25 ± 25 °CCurrent signal --- $\pm 0.6\%$ FS / 25 ± 25 °C

(for pneumatic pressure signal)

Influence of supply pneumatic pressure changes :

 $\pm 1.0\%$ FS / ± 20 kPaInfluence of power supply fluctuations (load 250Ω) : $\pm 0.3\%$ FS / $\pm 15\%$ of rated voltage**Withstand voltage**

Between terminal and cabinet ground: 40 V AC for 1 minute

*1)

(500 V AC for 1 minute without surge absorber)

Insulation resistance100 M Ω or more between terminal and cabinet ground *1)

(at 500 V DC without surge absorber)

*1) When performing an insulation and withstand voltage test, disconnect the jumper plate on the top left of the power terminal board to protect the surge absorber.)

Electrical wiring (Recommended wiring specifications)

Cable length: 1 km max.

Recommended wires:

Up/down signal

Pulse train input: KPEV-S

Pulse width input: CVV-S

Other signals: CVV-S

Ground the cable shields in the instrument room with at least Class 3 grounding.

Power supply24 V DC $\pm 15\%$

Current dissipation: 390 mA DC

Supply air pressure140 kPa ± 20 kPa { 1.4 ± 0.2 kgf/cm²}**Air consumption (in balanced state)**

6 L/min [N]

9 L/min [N] (model with manual operation unit)

Air supply rate

20 L/min [N]

Air load capacity

3 m + 20 cc or higher for 4 mm inner diameter pipe

Ambient temperature

0 to 50 °C (Normal operation condition)

-10 to 60 °C (Threshold operation condition)

Ambient humidity

10 to 90%RH

Construction

Waterproof (Equivalent to JIS F8001 Class 3 splash waterproof)

Mounting

2 inch pipe or wall mounted

Pneumatic piping connection

Rc1/4 (or 1/4 NPT internal thread)

Electrical connection

G3/4 (or 3/4 NPT internal thread)

Electrical wiring

M4 screw

Finish color

Cabinet

Dark beige

Pressure regulator with filter

Light beige

Weight

7 kg (including pressure regulator with filter)

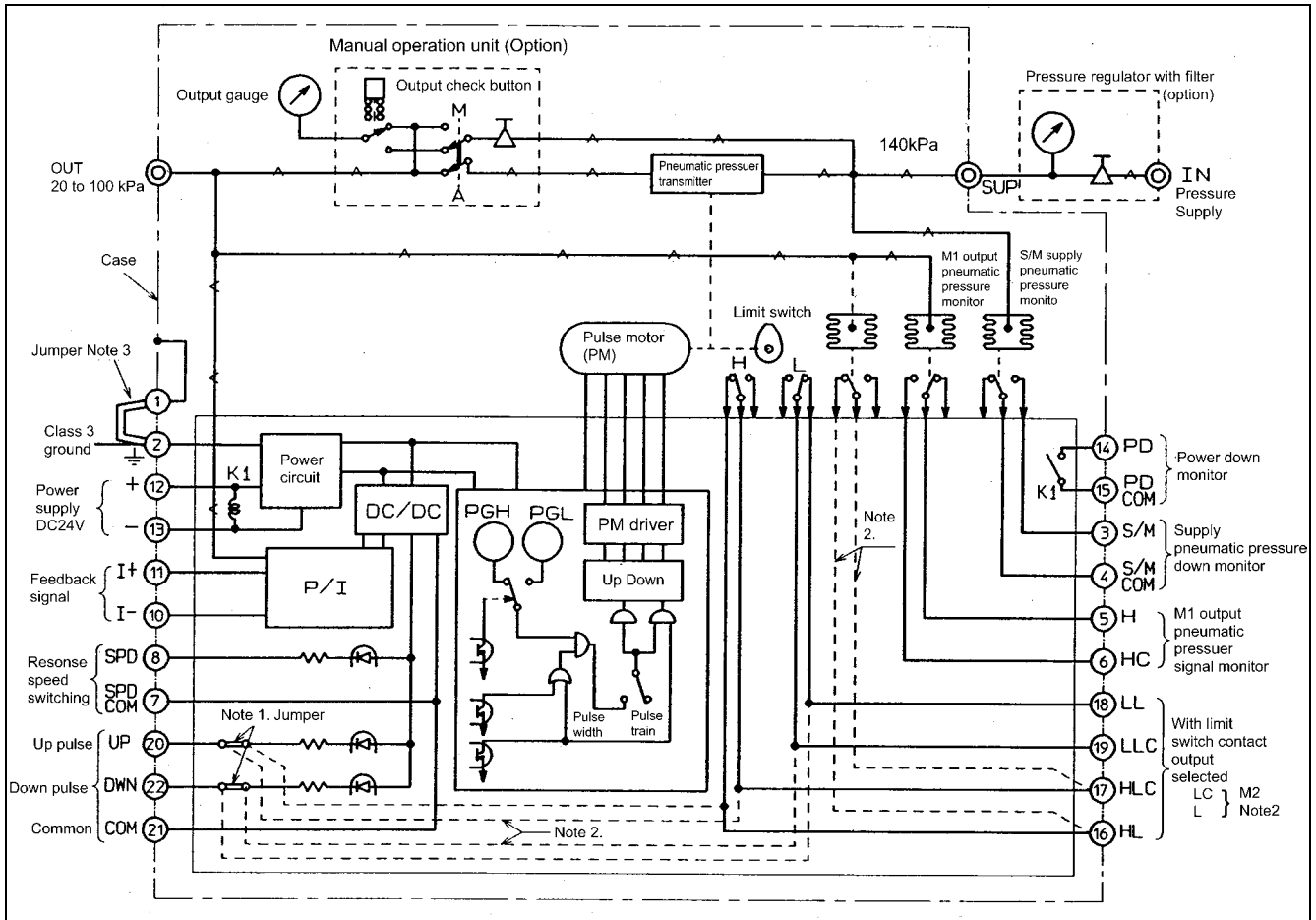

Figure 1. Functional Block Diagram

Note 1. Shorted when "Yes" is selected for limit switch contact output.

When "Yes" is selected for limit switch contact output, it is recommended to cut off the UP and Down input pulse signal at the limit values (limit H and Limit L) using an external sequence circuit. Excessively high input pulses cause hitting of the mechanical stopper and chattering of the worm gear mechanism.

The ball bearing of the worm gear shaft will be destroyed by long-term operation in a chattering state.

2. This is the wiring when "No" is selected for limit switch contact output. M2 can be added only in this case.

3. Be sure to disconnect the jumper plate to perform withstand voltage and insulation resistance tests.

* Power down monitor contact display (Model No.)

Normally closed (H) – Contact closed during power supply (Open during power failure)

Normally open (K) – Contact open during power supply (Closed during power failure)

* Limit switch, pneumatic pressure down monitor, M1, M2 contact display (Normally closed contacts are shown.)

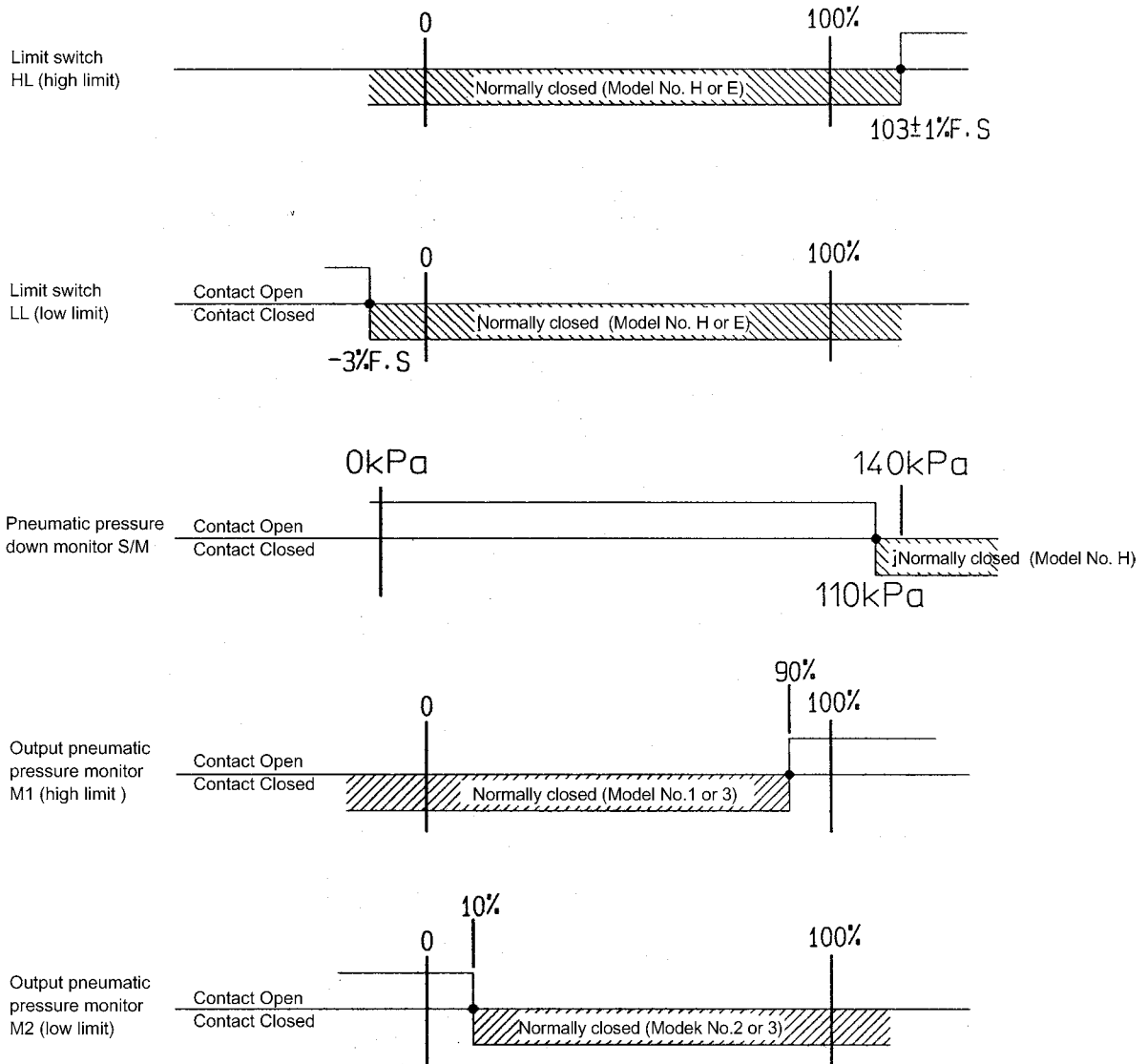

MODEL SELECTION

Multifunction pulse/Pneumatic Pressure Converter Model J - APN11

Multifunction Pulse/Pneumatic Pressure Converter (Model J - APN11)

Model No. Structure : J - APN11 - (1)(2)(3)(4)(5)(6)(7)(8)(9)(10)(11)(12)(13)(14) - Optional Specifications

Basic Model No.

Multifunction Pulse/Pneumatic Pressure Converter	J - APN11
--	-----------

Selections

(1)	Power Supply Unit	24V DC Isolation type	B	
(2)	Input Signal	Pulse Length	I	
		Pulse Row	J	
(3)	Pneumatic Pressure Output Singnal	0.2 to 1.0 kgf / cm ²		1
		3 to 15 psi		2
		0.2 to 1.0 bar		3
		20 to 100 kpa		4
(4)	Current Signal	4 to 20 mA DC		1
		20 to 4 mA DC(reverse characteristics)		2
(5)	External Connection	Pneumatic Rc1/4, Electric G3/4 Internal thread	R	
		Pneumatic 1/4 NPT, Electric G3/4 NPT Internal thread	N	(See Note 1)
(6)	Case Finish	Standard		1
		Corrosion - proof		2 (See Note 2)
		Heavy duty corrosion - proof		3 (See Note 2)
		Silver - painted		4 (See Note 2)
		Corrosion - proof silver - painted		5 (See Note 2)
(7)	Mounting bracket	for 2 in. pipe	T	
		for wall	S	
(8)	Water - resistant Gland	N/A	X	
		SUS304 (Packing diameter : 12)		1 (See Note 1)
		SUS304 (Packing diameter : 13)		2 (See Note 1)
		SUS304 (Packing diameter : 15)		3 (See Note 1)
(9)	Power Failure Monitor	N/A	X	
		Normally close	H	
		Normally open	K	
(10)	Pneumatic Pressure Failure Monitor	N/A	X	
		Normally close	H	
		Normally open	K	
(11)	Pneumatic Pressure Output Signal Monitor	N/A	X	
		One point (Upper), Normally close		1
		One point (Lower), Normally close		2
		Two points (Upper and lower), Normally close		3 (See Note 3&4)
		One point (Upper), Normally open		4
		One point (Lower), Normally open		5
		Two points (Upper and lower), Normally open		6 (See Note 3&4)
(12)	Case	Water - resistant	W	
(13)	Power supply for P/I Unit	Integrally mounted in the case		1
		External		2
(14)	Limit Contact Signal	Contact Output available, Normally closed	H	(See Note 3)
		Contact Output available, Normally open	K	(See Note 3)
		Contact Output unavailable, Normally closed.	E	

Options

	N/A		X
	Manual Operation Unit		M (See Note 4)
	Pressure regulator with filter		7

Note 1 : Water - resistant gland unavailable for External Connection N.

2 : Additional price for Regulator with Air Filter selected is shown parenthesized.

3 : Two points pneumatic Pressure Output Signal Monitor unavailable with Limit Contact Output Signal available selected.

4 : Manual Operation Unit unavailable with Two points Pneumatic Pressure Output Signal Monitor Selected.

DIMENSIONS

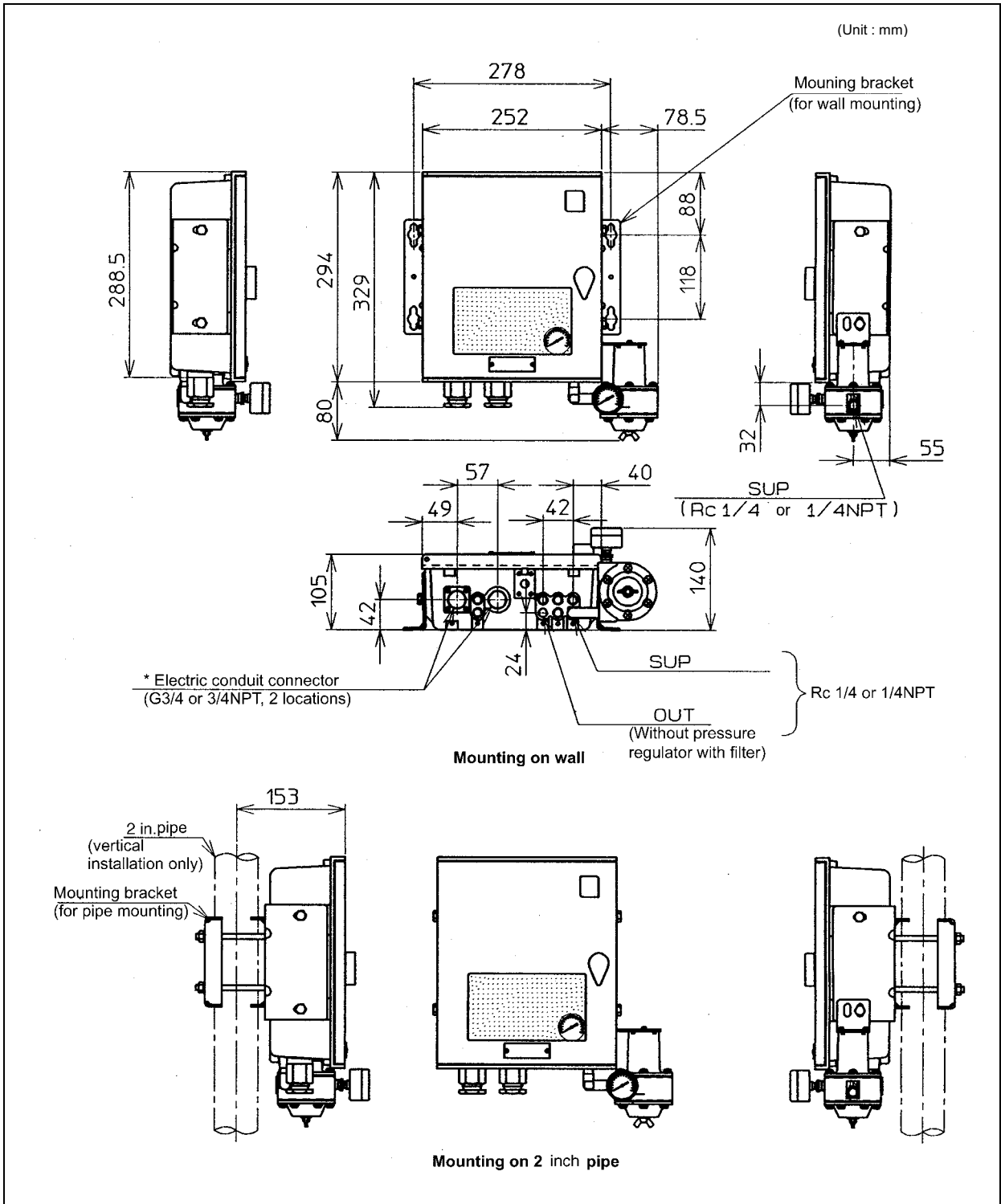

Figure 3. External Dimensions

SUS water-proof gland used

*Applicable cable specifications

Packing hole diameter	Applicable cable diameter
12	11.0 to 11.9
13	12.0 to 12.9
15	14.0 to 15.0

Note that applicable cable diameter for plastic water-proof glands is 14.0 to 15.0 only.

Yamatake Corporation

Totate International Building
2-12-19 Shibuya
Shibuya-ku, Tokyo 150-8316
Japan

Tel : 81-3-3486-2216
Fax : 81-3-3486-2503



Certificate No. Q17862

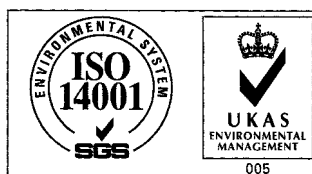

Certificate No. E8318
For Shonan Factory

YAMATAKE

Savemation

Saving through Automation