

IP50SL/SH INTELLPAK Selector User's Manual



Thank you for purchasing the IP50SL/SH. This manual contains information for ensuring correct use of the IP50SL/SH. It also provides necessary information for installation, maintenance, and troubleshooting. This manual should be read by those who design and maintain devices that use the IP50SL/SH. Be sure to keep this manual nearby for handy reference.

RESTRICTIONS ON USE

This product has been designed, developed and manufactured for general-purpose application in machinery and equipment.

Accordingly, when used in applications outlined below, special care should be taken to implement a fail-safe and/or redundant design concept as well as a periodic maintenance program.

- Safety devices for plant worker protection
- Start/stop control devices for transportation and material handling machines
- Aeronautical/aerospace machines
- Control devices for nuclear reactors

Never use this product in applications where human safety may be put at risk.

NOTICE

Be sure that the user receives this manual before the product is used.

Copying or duplicating this user's manual in part or in whole is forbidden. The information and specifications in this manual are subject to change without notice.

Considerable effort has been made to ensure that this manual is free from inaccuracies and omissions. If you should find an error or omission, please contact Yamatake Corporation.

In no event is Yamatake Corporation liable to anyone for any indirect, special or consequential damages as a result of using this product.

©2007 Yamatake Corporation ALL RIGHTS RESERVED

SAFETY PRECAUTIONS

Safety precautions are for ensuring safe and correct use of this product, and for preventing injury to the operator and other people or damage to property. You must observe these safety precautions. Also, be sure to read and understand the contents of this user's manual.



WARNING

Warnings are indicated when mishandling this product might result in death or serious injury to the user.



CAUTION

Cautions are indicated when mishandling this product might result in minor injury to the user, or only physical damage to this product.



CAUTION

- Before wiring, removing, or mounting the IP50SL/SH, be sure to turn the power OFF. Otherwise, touching electrically charged parts could cause electric shock.



CAUTION

- Use the IP50SL/SH within the operating ranges given in the specifications for temperature, humidity, voltage, vibration, shock, mounting direction, atmosphere, etc. Failure to do so could cause malfunction.
- Do not allow lead clippings, chips or water to enter the case. Doing so could cause fire or faulty operation.
- Firmly tighten the terminal screws at the torque listed in the specifications. Insufficient tightening of terminal screws could cause electric shock or fire.
- Do not use unused terminals on the IP50SL/SH as relay terminals. Doing so could cause electric shock, fire, or faulty operation.
- Do not block ventilation holes. Doing so could cause fire or faulty operation.
- Do not touch electrically charged parts such as the power terminals. Doing so could cause electric shock.
- Do not disassemble the IP50SL/SH. Doing so could cause electric shock or faulty operation.

Conventions Used in This Manual

The following conventions are used in this manual:

! Handling Precautions:

Handling Precautions indicate items that the user should pay attention to when handling the IP50SL/SH.

- (1), (2), (3): Numbers within parentheses indicate steps in a sequence or parts of an explanation.

1. Outline

The IP50SL/SH is a thin, plug-in type selector that automatically chooses one signal from two DC input signals. The high selector function chooses the higher of two signals and the low selector function chooses the lower one.

2. Mounting

■ Mounting locations

Install the IP50SL/SH so as to avoid the following:

- High and low temperatures and humidity
- Direct sunlight, outdoor locations exposed to wind and rain
- Splashing liquid such as water, oil, or chemicals
- Corrosive or flammable gases
- Dust and soot
- Mechanical vibration and shock
- Strong electric or magnetic fields
- Sources of electrical noise, such as high voltage ignition devices or welding machines

❗ Handling Precautions:

- When installing the IP50SL/SH in a place subject to mechanical vibration or shock, attach a damping bracket like the QN718A (sold separately). A damping bracket cannot be attached if the IP50SL/SH is mounted on a DIN rail.
- When installing the IP50SL/SH in place with much dust or metal powder, mount it in a case designed to be dustproof, and take measures to prevent excessive heat.

■ Installation

The IP50SL/SH plugs into a socket which can be attached directly to a wall or to a DIN rail.

● Lateral installation layout

When installing multiple IP50SL/SH units side by side, use the layout shown below.

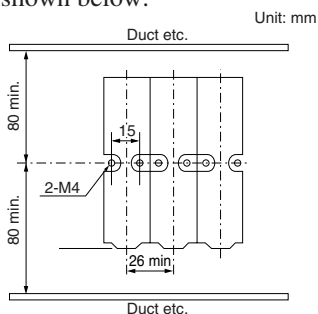

● Installation layout with damping bracket

When installing the IP50SL/SH with the damping bracket, use the layout shown below. (The QN718A damping bracket is sold separately.)

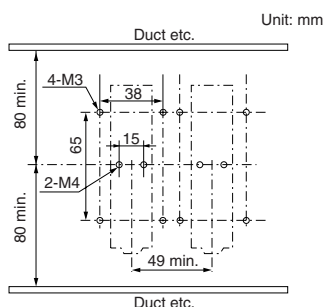

● How to attach the IP50SL/SH to the DIN rail

(1) Attach the socket first

With the slider on the base of the socket facing downward, hook the socket onto the DIN rail. Then push in the base of the socket, as shown in the drawing.

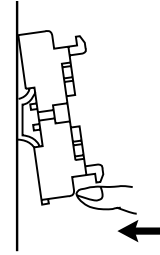

(2) Attach the IP50SL/SH

Push the IP50SL/SH straight into the socket. The label lettering should be pointing the right way. Be sure to push the unit firmly into the socket.

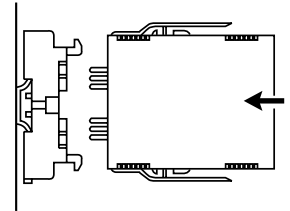

■ Removing

(1) If the damping bracket is attached to the IP50SL/SH, remove the damping bracket first. Then remove the IP50SL/SH from the socket.

(2) How to remove the IP50SL/SH from the socket

First make sure that the IP50SL/SH is fully pushed onto the socket. Fully press both upper and lower levers on the IP50SL/SH and pull it straight off the socket. Pulling it off when the levers are not sufficiently pressed can damage the socket.

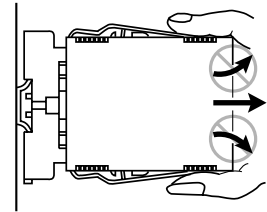

(3) How to remove the socket from the DIN rail

Insert a flat-head screwdriver into the slit of the DIN rail holder, and pull it down. Then lift the socket off the DIN rail in the direction shown by the arrow in the figure right.

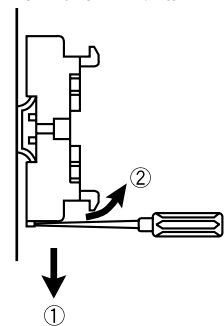

3. Wiring

Wire the unit as shown in the figure below. Use M3.5 crimp contacts for wiring.

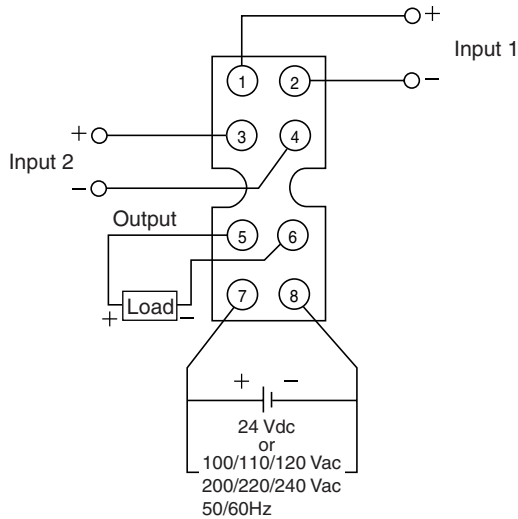

Term.No.	Signal		Content
1	Input 1	+	Connect the required input signals.
2		-	
3	Input 2	+	Connect the required input signals.
4		-	
5	Output	+	The output signal depends on the model number.
6		-	
7	Power	+	Connect to a power source having the rated voltage.
8		-	

! Handling Precautions:

- Be sure to use insulated crimp contacts for terminal connections. When installing the IP50SL/SH in a place with heavy mechanical vibration or shock, use ring terminals so that they do not come loose.
- Make sure that nearby terminal lugs do not touch each other.
- Keep the input/output signal line 50cm or more away from any power lines carrying over 100V. Do not put them in the same conduit or duct.
- Before wiring double-check the model No. and terminal Nos. on the attached label
- Before turning the power on, be sure that all wiring is correct.
- Though the IP50SL/SH is operational as soon as the power is turned on, wait 30 minutes or more to satisfy the accuracy levels stated in the specifications.
- Do not short circuit output terminals on the voltage output model. Doing so could cause damage.
- Use an integral analog-to-digital converter to convert the analog output into digital output. When using a high-speed analog-to-digital converter such as successive approximation type, make sure to operate by combined test beforehand.

4. Input-output characteristics

The relation between input and output is shown in the figure below.

● Low selector

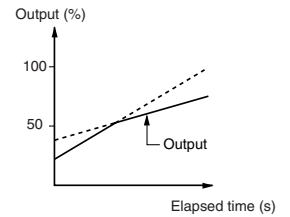
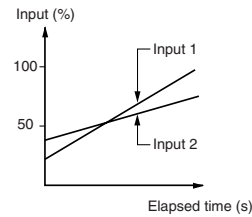

● High selector

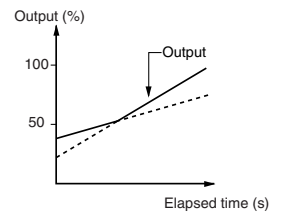
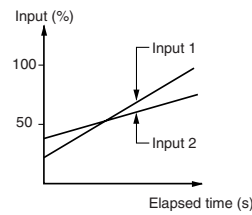

5.Adjustment

■ Zero and span adjustment

The IP50SL/SH is calibrated before shipping. Generally it is not necessary to adjust the zero or span potentiometers on the front panel. When an adjustment is required in order to coordinate with associated instruments, or for periodic inspection, follow the procedure below.

❗ Handling Precautions:

- The amount of adjustability for zero and span is about 10%.
- The potentiometer knob does not have a stop to limit turning. Do not turn it too much.

● Required equipment

- Signal source (standard voltage/current generator) with at least 10 times the accuracy of the IP50SL/SH
- Voltmeter/ammeter

● Adjustment procedure

- (1) Wait 30 minutes or more after turning the power on.
- (2) Apply the minimum signal for the input range to the input terminals.
- (3) Turn the ZERO potentiometer so that the output signal is at the minimum for the output range.
- (4) Next, apply the maximum signal for the input range to the input terminals.
- (5) Turn the SPAN potentiometer so that the output signal is at the maximum for the output range.

• Zero adjustment

Output type	4 to 20mA	0 to 20mA
Rotation		
The zero point shifts upward. (⊕ ZERO) The zero point shifts downward.		

• Span adjustment

Output type	4 to 20mA	0 to 20mA
Rotation		
The span expands. (⊕ SPAN) The span narrows.		

■ Behavior for out of specifications inputs/loads

● Excessive input

If the input signal exceeds the upper limit for the range, the output signal increases to 120% FS (or more) in approximate proportion to the input signal.

● Insufficient input

• Current output type

If the input signal is below the lower limit for the range, the output signal decreases to -20% FS (or less) in approximate proportion to the input signal. However, negative current is not output.

• Voltage output type

If the input signal is below the lower limit for the range, the output signal decreases to -120% FS (or less) in approximate proportion to the input signal.

● Load resistance outside of specifications

• Current output type

If the load resistance exceeds the allowable range, the voltage across the output terminals increases to about 16V in approximate proportion to the input signal. Above 16V, the output reaches its limit and the error becomes larger.

• Voltage output type

For load resistance below the allowable range, the output signal cannot increase proportionally, and the error becomes larger.

5. Specifications

■ Specifications

Input type	DC voltage and DC current, see table 1.		
Input impedance	See table 1		
Output type	DC voltage and DC current, see table 2.		
Allowable load resistance	See table 2.		
Accuracy	±0.1%FS at a reference temperature of 23°C		
Response time	25ms for 90% of response		
Zero/span adjustment	±10% FS each		
Power type	AC		DC
Rated voltage	100/110/120Vac (50/60Hz)	200/220/240Vac (50/60Hz)	24Vdc
Operating voltage	80 to 132Vac (45 to 65Hz)	170 to 264Vac (45 to 65Hz)	24Vdc±10%
Power consumption	4.5VA		2.2VA
Starting current	-		0.11A or less
Inrush current at power on	10A or less, 1ms		5A or less, 1ms
Insulation resistance	Between I/O terminal and power terminal, Between I/O terminals (for isolated type) 100MΩ or more by 500Vdc megger		
Dielectric strength	Between I/O terminal and power terminal, Between I/O terminals (for isolated type) 2000Vac 1 minute		
Power characteristics	±0.1% FS/80 to 132Vac or 170 to 264Vac		±0.1% FS/24Vdc±10%
Temperature characteristics	±0.15% FS/10°C		
Operating ambient temperature	-5 to +55°C		
Storage ambient temperature	-20 to +70°C		
Operating ambient humidity	90% RH or less (without condensation)		
Storage ambient humidity	90% RH or less (without condensation)		
Vibration resistance*	4.9m/s ² or less 10 to 60Hz X,Y,Z each direction 2h (with damping bracket)		
Shock resistance*	490m/s ² or less, upward and downward 3 times		
Case material	Heat resistant ABS resin		
Case color	Gray, Munsell color scale 2.5PB3.5/1		
Terminal screw	M3.5		
Terminal screw tightening torque	0.78 to 0.98N•m		
Mounting	Installed on wall or DIN rail		
Mass	200g (Including the base socket)		
Included accessories	Base socket parts number QN719A		
Optional parts (sold separately)	Damping bracket parts number QN718A		

* If unit is mounted on a DIN rail, these specifications do not apply.

■ Key to model numbers

I II III IV V

: IP50SLC14ADT0

I	II	III	IV	V	Description
Basic number	Input type	Output type	Power voltage	Additional features	
IP50SLA					Non-isolated low selector
IP50SLC					Isolated low selector
IP50SHA					Non-isolated high selector
IP50SHC					Isolated high selector
	Select from table 1	Select from table 2			
			A		100/110/120Vac 50/60Hz
			B		200/220/240Vac 50/60Hz
			D		24Vdc
				00	None
				T0	Tropicalization
				D0	With inspection data
				B0	Tropicalization and inspection data
				Y0	With traceability certification

Table 1. Input type Table 2. Output type

Code	Input type	Input impedance
13	0 to 5V	1MΩ
14	1 to 5V	1MΩ
15	0 to 10V	1MΩ
35	0 to 20mA	50Ω
36	4 to 20mA	50Ω

Input 1 and Input 2 must be the same input type.

Code	Output type	Allowable load resistance
A	4 to 20mA	750Ω or less
B	1 to 5mA	3kΩ or less
C	2 to 10mA	1.5kΩ or less
D	0 to 1mA	15kΩ or less
E	0 to 10mA	1.5kΩ or less
F	0 to 16mA	937Ω or less
G	0 to 20mA	750Ω or less
H	1 to 5V	2.5kΩ or more
J	0 to 10mV	10kΩ or more
K	0 to 100mV	100kΩ or more
L	0 to 1V	500Ω or more
N	0 to 5V	2.5kΩ or more
P	0 to 10V	5kΩ or more
R	±10V	5kΩ or more

External dimensions

Unit: mm

Base socket part number QN719A

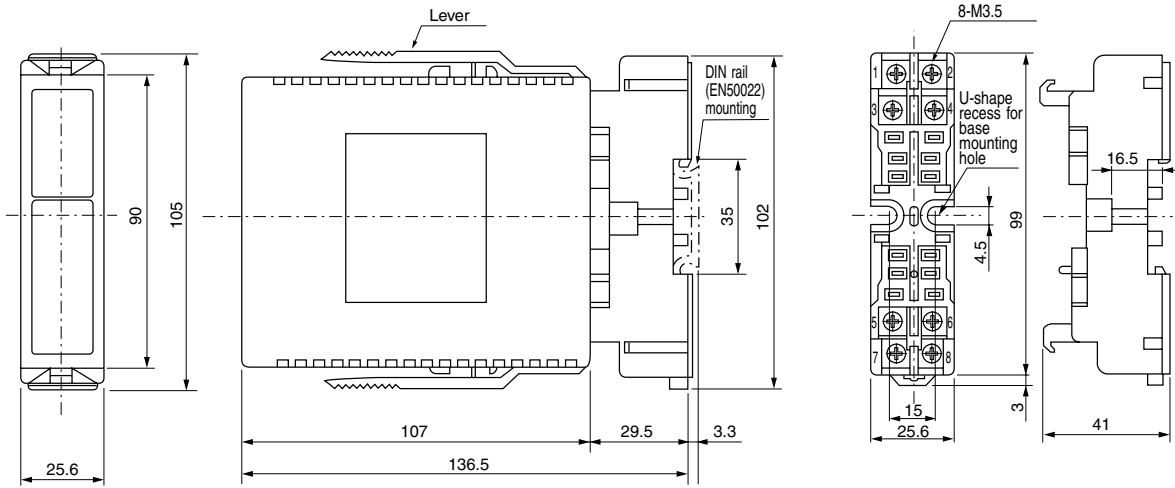

Damping bracket part number QN718A

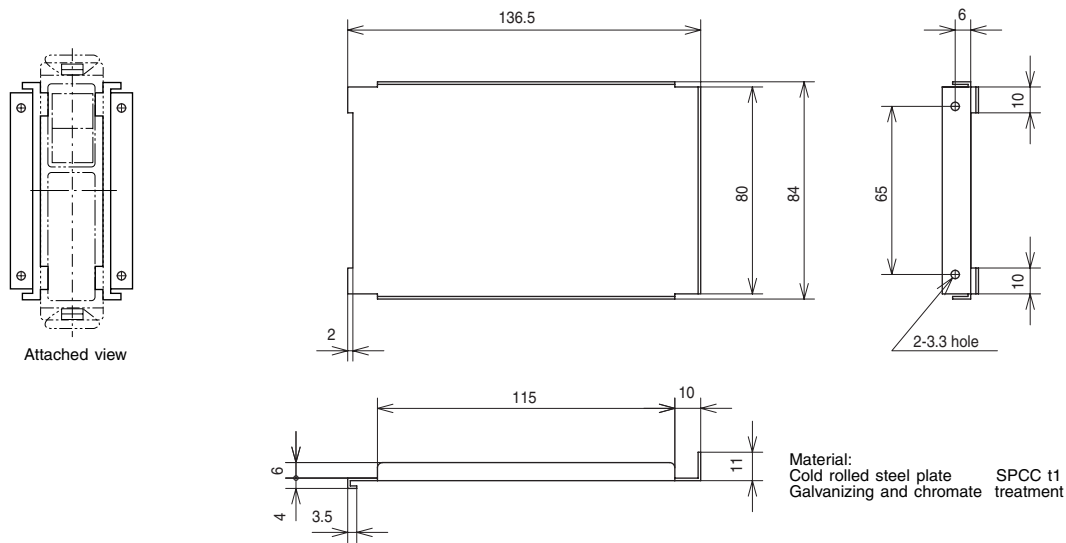

Circuit block diagram

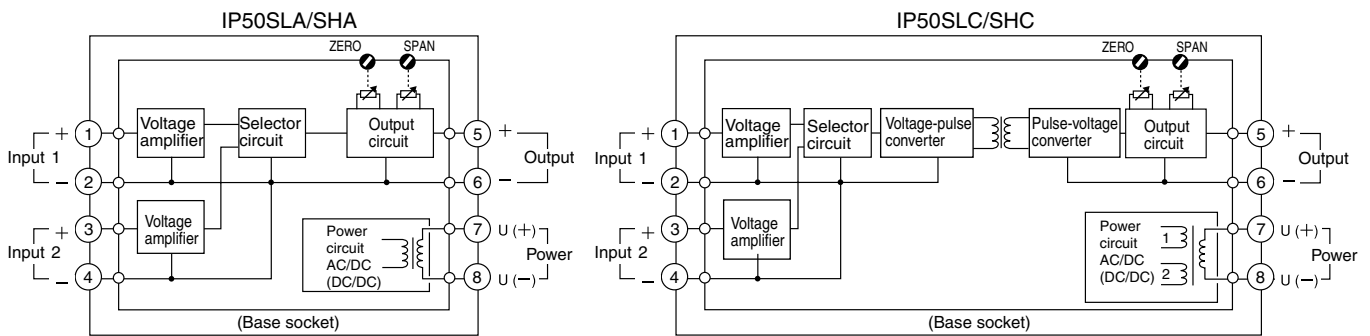

Yamatake Corporation
Advanced Automation Company

1-12-2 Kawana, Fujisawa
Kanagawa 251-8522 Japan

URL: <http://www.azbil.com>

Printed on recycled paper. (07)

Specifications are subject to change without notice.

Printed in Japan.
1st Edition: Issued in Feb. 2007 (U)