

## SDC45/46 Digital Indicating Controller User's Manual for Installation

Thank you for purchasing the SDC45/46 Digital Indicating Controller.

To ensure correct and safe operation of the SDC45/46, be sure to read and understand this user's manual.

Be sure to keep this manual nearby for handy reference.

### RESTRICTIONS ON USE

This product has been designed, developed and manufactured for general-purpose application in machinery and equipment.

Accordingly, when used in applications outlined below, special care should be taken to implement a fail-safe and/or redundant design concept as well as a periodic maintenance program.

- Safety devices for plant worker protection
- Start/stop control devices for transportation and material handling machines
- Aeronautical/aerospace machines
- Control devices for nuclear reactors

Never use this product in applications where human safety may be put at risk.

### NOTICE

Be sure that the user receives this manual before the product is used.

Copying or duplicating this user's manual in part or in whole is forbidden. The information and specifications in this manual are subject to change without notice.

Considerable effort has been made to ensure that this manual is free from inaccuracies and omissions. If you should find an error or omission, please contact Yamatake Corporation.

In no event is Yamatake Corporation liable to anyone for any indirect, special or consequential damages as a result of using this product.

©2007 Yamatake Corporation ALL RIGHTS RESERVED

### MANUALS

This manual explains the handling precautions, mounting, wiring, PV range type and main specifications only.

See the separate manuals listed below for detailed handling procedures, setting methods, etc.

These manuals also contain information on using various functions. Please read them as necessary.

- SDC45A/46A Displays and Settings (CP-SP-1265E)
- SDC45A/46A Installation and Configuration (CP-SP-1218E)

Manuals can be downloaded from  
<http://www.yamatake.com>.

### UNPACKING

Check the following items when removing the SDC45/46 from its package:

Item	Part No.	Qty.	Remarks
Mounting bracket	81405411-004	2	
Gasket (for SDC45)	81421863-001	1	
(for SDC46)	81421864-001	1	
User's manual	CP-UM-5445E	1	This manual
User's manual	CP-UM-5445	1	Japanese

If there is any problem with your order, please contact your sales representative immediately.

### SAFETY PRECAUTIONS

**WARNING**  
Warnings are indicated when mishandling this product might result in death or serious injury to the user.

**CAUTION**  
Cautions are indicated when mishandling this product might result in minor injury to the user, or only physical damage to this product.

### WARNING

- ❗ Before connecting the SDC45/46 to the measurement target or to external control circuits, make sure that the frame ground (FG) terminal is properly grounded with an earth of less than 100 Ω. Failure to do so might cause an electric shock or fire.
- ❗ Incorrect wiring of the SDC45/46 can damage the SDC45/46 and lead to other hazards. Check that the SDC45/46 has been correctly wired before turning the power ON.
- ❗ Before wiring, removing or mounting the SDC45/46, be sure to turn the power OFF. Failure to do so might cause electric shock or device failure.
- ⊘ Do not touch electrically charged parts such as the power terminals. Doing so might cause electric shock.
- ⊘ Do not disassemble the SDC45/46. Doing so might cause electric shock or device failure.

### CAUTION

- ❗ Use the SDC45/46 within the operating ranges recommended in the specifications (temperature, humidity, voltage, vibration, shock, mounting direction, atmosphere, etc.). Failure to do so might cause fire or device failure.
- ⊘ Do not block ventilation holes. Doing so might cause fire or device failure.
- ❗ Wire the SDC45/46 properly using the specified types of wire and following recognized installation methods. Failure to do so might cause electric shock, fire or device failure.
- ❗ Do not allow wire clippings, chips or water to enter the controller case. They might cause fire or device failure.
- ❗ Firmly tighten the terminal screws to the torque listed in the specifications. Insufficient tightening of terminal screws might cause electric shock or fire.
- ⊘ Do not use unused terminals on the SDC45/46 as relay terminals. Doing so might cause electric shock, fire or device failure.
- ⚠ We recommend attaching the terminal cover (sold separately) after wiring the SDC45/46. Failure to do so might cause electric shock.
- ❗ Use the relays within the recommended service life. Failure to do so might cause fire or device failure.
- ❗ Use Yamatake Corporation's SURGENON if there is a risk of power surges caused by lightning. Otherwise fire or device failure could result.
- ⊘ Do not operate the keys with a mechanical pencil or other sharp-tipped object. Doing so might cause device failure.
- ❗ After the power has been turned ON, the SDC45/46 does not operate for 2 to 60 s according to the settings. Therefore, great care should be taken if the relay output from the controller is used as an interlock signal.
- ❗ Please dispose of used batteries properly, in accordance with local bylaws and regulations.

### MOUNTING

#### Location

Install the controller in a location that meets the following criteria:

- Voltage to ground of 33 V r.m.s max., 46.7 V peak max., and 70 Vdc max.
- No high/low temperature/humidity.
- Free from sulfide gas or corrosive gas.
- Not dusty or sooty.
- Protected from direct sunlight, wind, and rain.
- Little mechanical vibration or shock.
- Not close to high voltage line, welding machine or other electrical noise generating source.
- At least 15 meters away from the high voltage ignition device for a boiler.
- No strong magnetic fields.
- No flammable liquid or gas.

#### Mounting procedure

- Mount horizontally with the back not tilted more than 10° up or down.
- The mounting panel should be rigid and no more than 7 mm thick (5 mm max. when a gasket is used).

#### Handling Precautions

- When used as a waterproof unit, be sure to install a gasket.

#### External dimensions

##### • SDC45

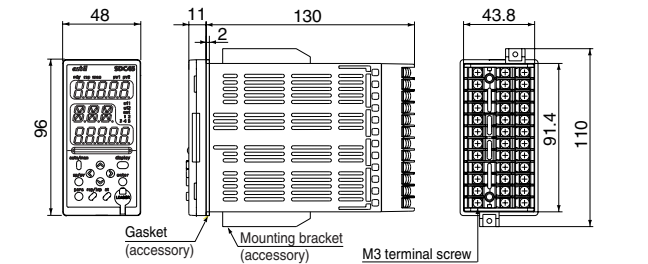

##### • SDC46

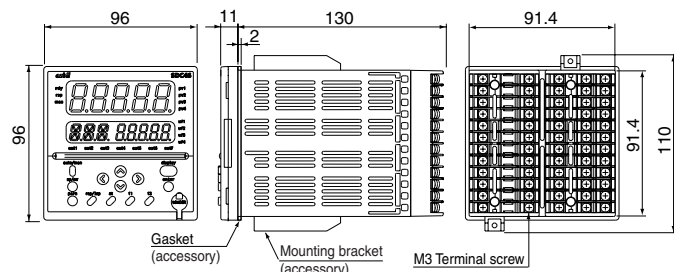

#### Handling Precautions

- To fasten this controller onto the panel, tighten the mounting bracket screws until there is no play between the bracket and panel, and then turn one more full turn. Excessively tightening the screws may deform the controller case.

#### Panel cutout dimensions

##### • SDC45

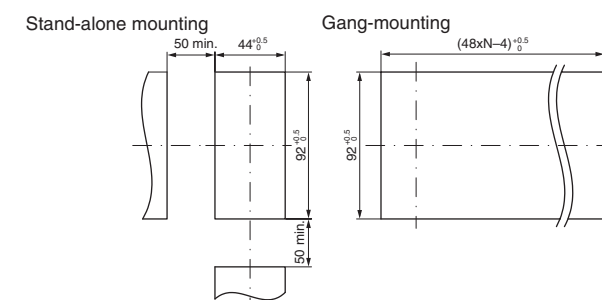

##### • SDC46

Stand-alone mounting

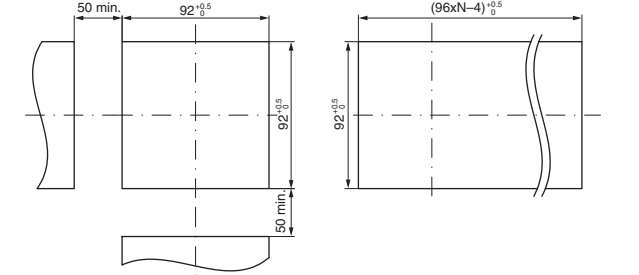

#### Handling Precautions

- When used as a waterproof unit, be sure to install a gasket.
- When three or more units are gang-mounted horizontally, the maximum allowable ambient temperature is 40 °C.
- Provide a space of at least 50 mm or more above and below the controller.

### WIRING

Be sure to provide a switch within operator reach for shutting off the main power supply to the controller in the main supply wiring. Also, in case of AC power supply models, the main supply wiring also requires a time-lagged (T) fuse rated at 1.0A, 250 V. (IEC127)

Symbols used on the wiring label on the controller side:

Symbol	Meaning
~	AC power supply
—	DC power supply
⚠	Caution, danger of electric shock
⚠	Caution

#### Handling Precautions

- Before wiring the SDC45/46, verify the controller's model No. and terminal Nos. written on the label on the side. Inspect all wiring once wiring work has been completed.
- Use M3 crimp-type terminal lugs for wiring to terminals.
- Leave a distance of at least 50 cm between I/O lead wires or communications lead wires and power lead wires. Also, do not pass these lead wires through the same conduit or wiring duct.
- Be careful not to allow any crimp-type terminal lugs to touch adjacent terminals.
- Be sure that any device or equipment which is connected to this controller has adequate insulation for the controller's power supply voltage and maximum I/O voltages.
- The controller requires 2 to 60 seconds according to the settings to start up once the power is turned ON. A warm-up time of at least 30 minutes is recommended to allow the controller to attain the specified accuracy.
- Prepare a heater current conductor to send a heater current through the current transformer. Do not use a heater current that exceeds the specified permissible current as this may damage the controller.
- The current transformer input cannot be used for phase control.
- Do not wire in the same duct for the motor drive terminals and the MFB input terminals and also do not use 6-core cable. Failure to follow the instruction might cause controller malfunction due to noise during motor startup operation.

● Wiring

● SDC45 rear panel

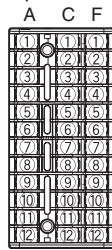

● SDC46 rear panel

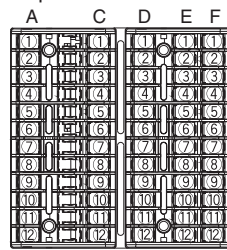

A (both SDC45 and 46)

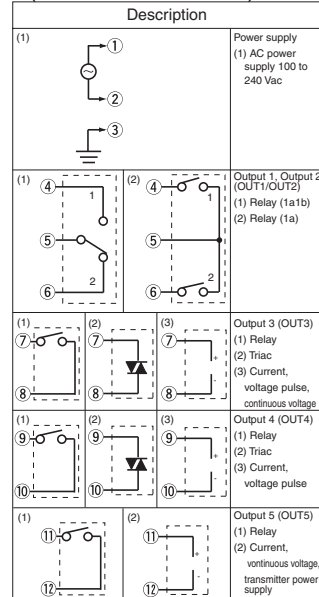

C (SDC45)

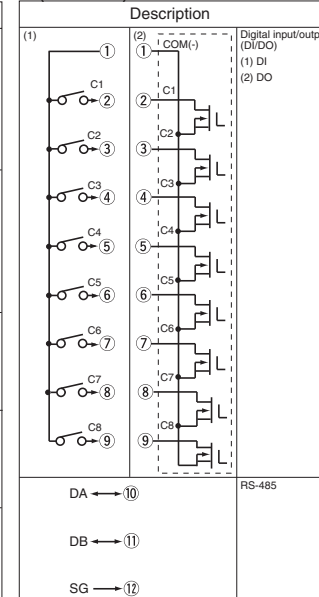

C (SDC46)

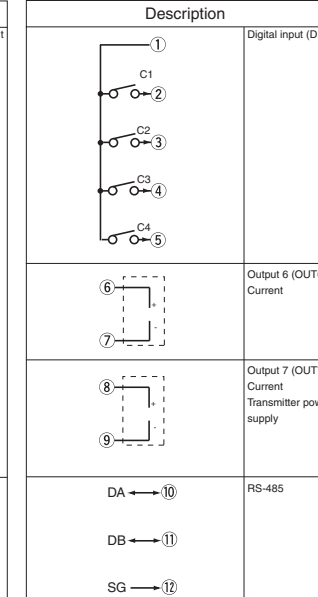

D (SDC46)

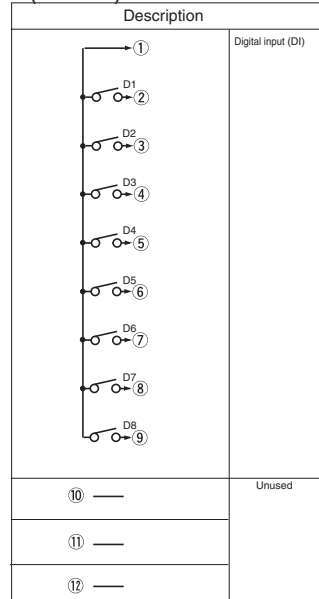

E (SDC46)

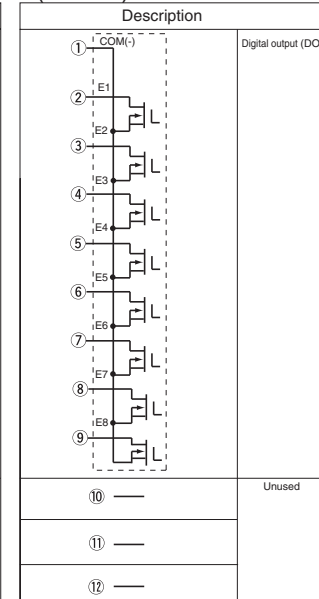

F (both SDC45 and 46)

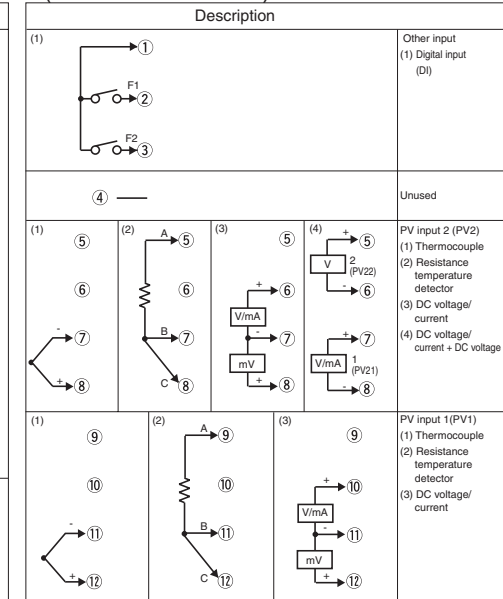

\* Only 3-input SDC45V/46V model.

● I/O isolation

Items surrounded by solid lines are isolated from other signals. Availability of inputs and outputs varies depending on the model number.

PV1	Internal circuit	OUT1
PV2/PV21*/PV22*		OUT2
DI-C1 to DI-C8		OUT3
DI-D1 to DI-D8		OUT4
DI-F1 to DI-F2		OUT5
MFB		OUT6
CT1/CT2		OUT7
		DO-C1 to DO-C8
		DO-E1 to DO-E8
		RS-485
		Loader

The power circuit is isolated from all inputs/outputs, communications and internal circuits.

⚠ Handling Precautions

- The loader jack is not isolated from the internal circuits. Always put the cap on the loader jack when the loader is not used.

\* Only 3-input SDC45V/46V model.

NAMES AND FUNCTION OF PARTS

● SDC45A front panel

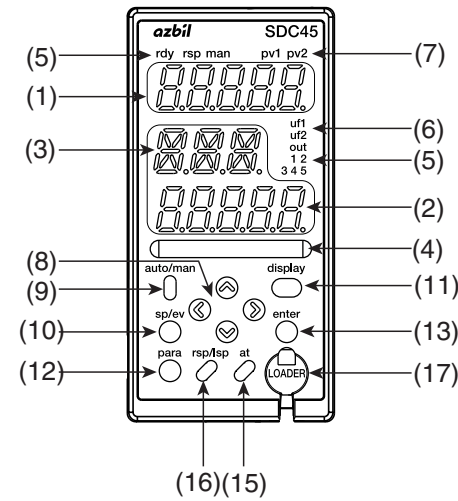

● SDC46A front panel

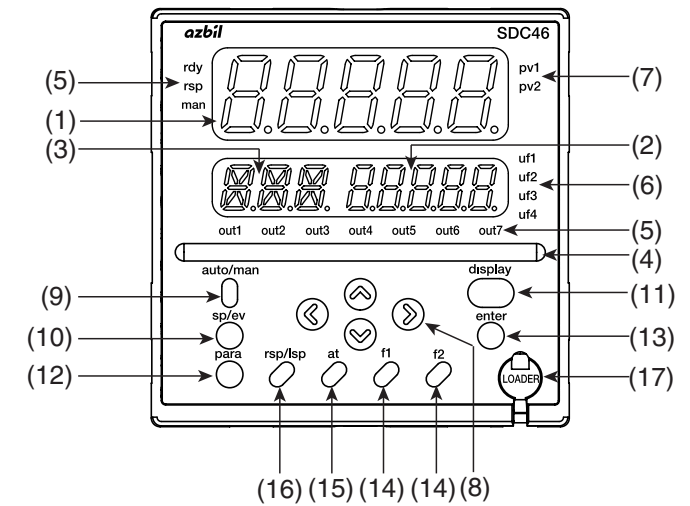

- (1) Upper display: Displays PV (present temperature etc.) or setup items.
- (2) Lower display: Displays SP (set temperature, etc.) and other parameters.
- (3) Auxiliary display: Displays group No., loop No., and channel No. of setup item.
- (4) Multi-status indicator: Indicates MV or DI/DO status.
- (5) Mode indicators:  
rdy: Lights up in READY mode.  
rsp: Lights up in RSP (remote setting input) mode.  
man: Lights up in MANUAL mode.  
out1-7: Light up when the output is ON (SDC45: out1-5).
- (6) User function indicators:  
uf1-4: Light under user-assigned conditions (SDC45: uf1, uf2).
- (7) Loop number indicators:  
pv1, pv2: Light up to indicate which loop has the displayed PV value.
- (8) [ ^ ], [ v ], [ < ], [ > ] keys: Used to increment/decrement numeric values and shift between digits or settable items.
- (9) [ auto/man ] key: Used to change AUTO/MANUAL mode.
- (10) [ sp/ev ] key: Used to set the SP/EV bank.
- (11) [ display ] key: Used to change the display contents in the operation display mode.
- (12) [ para ] key: Used to set the PARA bank.
- (13) [ enter ] key: Used in initiating setup and to confirm changed values.
- (14) [ f1 ], [ f2 ] keys: Used for user-assigned functions (SDC46 only).
- (15) [ at ] key: Used to execute/cancel auto-tuning, or for user-assigned functions.
- (16) [ rsp/lsp ] key: Used to change between remote and local set point, or for user-assigned functions.
- (17) Loader jack: Jack for connection of PC loader cable (with cap).

## PV RANGE TABLE

Input indication accuracy differs depending on the sensor type. If PV-01 is set to a value that is not in the tables below, the input indication will be fixed at 0.0.

### ■ Thermocouple

On the 3-input model, thermocouple input cannot be used for PV21/22.

PV-01 setting	Sensor type	Range	Input indication accuracy
1	K	-270.0 to +1372.0 °C -454 to +2502 °F	Under -200 °C: ±20.0 °C, Under -100 °C: ±1.0 °C, Under 400 °C: ±0.5 °C, 400 °C and above: ±0.1 % rdg. ±1 digit
2	E	-270.0 to +1000.0 °C -454 to +1832 °F	Under -200 °C: ±15.0 °C, Under -100 °C: ±1.0 °C, Under 400 °C: ±0.5 °C, 400 °C and above: ±0.1 % rdg. ±1 digit
3	J	-200.0 to +1200.0 °C -328 to +2192 °F	Under -100 °C: ±1.0 °C, Under 400 °C: ±0.5 °C, 400 °C and above: ±0.1 % rdg. ±1 digit
4	T	-270.0 to +400.0 °C -454 to +752 °F	Under -200 °C: ±10.0 °C, Under -100 °C: ±1.0 °C, -100 °C and above: ±0.5 °C
5	B	0.0 to 1800.0 °C 32 to 3272 °F	Under 260 °C: ±70 °C, Under 800 °C: ±4 °C, 800 °C and above: ±2 °C
6	R	-50.0 to +1768.0 °C -58 to +3214 °F	Under 0 °C: ±4.0 °C, Under 1000 °C: ±2.0 °C, 1000 °C and above: ±0.1 % rdg. ±1 digit
7	S	-50.0 to +1768.0 °C -58 to +3214 °F	Under 0 °C: ±4.0 °C, Under 1000 °C: ±2.0 °C, 1000 °C and above: ±0.1 % rdg. ±1 digit
8	WRe5-26	0.0 to 2300.0 °C 32 to 4172 °F	Under 1400 °C: ±1.5 °C, 1400 °C and above: ±0.1 % rdg. ±1 digit
9	PR40-20	0.0 to 1900.0 °C 32 to 3452 °F	Under 300 °C: ±40 °C, Under 800 °C: ±20 °C, 800 °C and above: ±8 °C
10	Ni-Ni-Mo	0.0 to 1300.0 °C 32 to 2372 °F	±1.4 °C
11	N	-200.0 to +1300.0 °C -328 to +2372 °F	Under 0 °C: ±4.0 °C, 0 °C and above: ±1.4 °C
12	PL II	0.0 to 1390.0 °C 32 to 2534 °F	±1.4 °C
13	DIN U	-200.0 to 600.0 °C -328 to +1112 °F	Under 0 °C: ±1.0 °C, 0 °C and above: ±0.7 °C
14	DIN L	-200.0 to +900.0 °C -328 to +1652 °F	Under 0 °C: ±1.5 °C, 0 °C and above: ±1.0 °C
15	Gold iron/Chromel	-273.0 to +27.0 °C -459 to +80 °F	±1.5 °C

### ■ Resistance temperature detector

On the 3-input model, RTD input cannot be used for PV21/22.

PV-01 setting	Sensor type	Range	Input indication accuracy
21	Pt100	-200.0 to +850.0 °C -328.0 to +1562.0 °F	±0.3 °C
22		-200.00 to +300.00 °C -328.00 to +572.00 °F	±0.15 °C
31	JPt100	-200.0 to +640.0 °C -328.0 to +1184.0 °F	±0.3 °C
32		-200.00 to +300.00 °C -328.00 to +572.00 °F	±0.15 °C

### ■ DC voltage, DC current

On the 3-input model, PV21 can be set to 41, 42, 49, 51, or 51; and PV22 can be set to 49, 50 or 51.

PV-01 setting	Input type	Range	Input indication accuracy
41	Current	4 to 20 mA	±0.1 % FS ± 1 digit
42		0 to 20 mA	
43	Voltage	0 to 10 mV	
44		-10 to +10 mV	
45		0 to 100 mV	
46		-100 to +100 mV	
47		0 to 1 V	
48		-1 to +1 V	
49		1 to 5 V	
50		0 to 5 V	
51		0 to 10 V	

## ALARM CODE LIST

Alarm codes and countermeasures in case of abnormal operation of this controller.

Alarm code	Failure name	Cause	Corrective action
<i>RL01</i>	PV1 input failure (over-range)	Sensor burnout, incorrect wiring, incorrect PV1 range type setting.	Check the wiring, reset PV1 range type ( <i>Pv-01</i> ) or reset PV1 range upper/lower value. ( <i>Pv-04</i> : range lower value, <i>Pv-05</i> : range upper value.)
<i>RL02</i>	PV1 input failure (under-range)		
<i>RL03</i>	PV2/PV21 input failure (over-range)	Sensor burnout, incorrect wiring, incorrect PV2/PV21 range type setting.	Check the wiring, reset PV2/PV21 range type ( <i>Pv-02</i> ) or reset PV2/PV21 range upper/lower value. ( <i>Pv-04</i> : range lower value, <i>Pv-05</i> : range upper value.)
<i>RL04</i>	PV2/PV21 input failure (under-range)		
<i>RL05</i>	PV22 input failure (over-range)	Sensor burnout, incorrect wiring, incorrect PV22 range type setting.	Check the wiring, reset PV22 range type ( <i>Pv-01</i> ) or reset PV22 range upper/lower value. ( <i>Pv-04</i> : range lower value, <i>Pv-05</i> : range upper value.)
<i>RL06</i>	PV22 input failure (under-range)		
<i>RL21</i>	MFB input failure	Burnout, incorrect wiring.	Check the wiring.
<i>RL22</i>	Motor adjustment failure	Burnout, incorrect wiring, Motor power shutdown.	Readjust the motor after checking the wiring and motor power.
<i>RL25</i>	CT1 input failure	CT input over-range	Check CT input.
<i>RL26</i>	CT2 input failure	Incorrect CT range type setting.	Reset CT input.
<i>RL71</i>	Abnormal PV1 CJ compensation	Abnormal terminal temperature.	Check the ambient temperature.
<i>RL72</i>	Abnormal PV2 CJ compensation	(thermocouple)	
<i>RL81</i>	Battery low (only SDC45V/46V)	Dead battery	Replace the battery.
<i>RL82</i>	Internal clock failure (only SDC45V/46V)	Dead battery, Hardware failure.	Reset the clock after battery is replaced.. Replace the unit.
<i>RL83</i>	Board configuration problem	Hardware failure.	Replace the unit.
<i>RL96</i>	Main board failure		
<i>RL97</i>	Parameter failure	•Power was turned OFF while setting data. •Data is corrupted due to noise, etc.	Restart the system. Reset data or replace the unit. ( <i>RL97</i> : setting data, <i>RL98</i> : adjustment data)
<i>RL98</i>	Adjustment data problem		
<i>RL99</i>	ROM failure	ROM (memory) is faulty.	Restart the system. Replace the unit.

## MODEL SELECTION TABLE

### ■ SDC45 (with 14-digit model No.)

All models have 2 digital inputs.

Basic model No.	Input model	Power supply	Output 1, 2	Output 3, 4	Output 5	Output 6, 7	Option	Addition 1	Addition 2	Specifications
C45A										Standard model
C45V										Computation function model
	1									1 input (full multiple 1) *1
	2									2 inputs (full multiple 2)
	3									3 inputs (full multiple 1, linear 2) *2
	A									100 to 240 Vac
	D									24 Vac/dc *6
			1							1 form 1a1b relay
			2							2 form 1a relays
				CO						Current (output 3)
				DO						Continuous voltage output (output 3)
				VO						Voltage pulse (output 3)
				RR						2 form 1a relays
				CC						2 current outputs
				VV						2 voltage pulse outputs
				CV						Current (output 3) + voltage pulse (output 4)
				SS						2 triac + 1 MFB input
				0						None
				R						Form 1a relay
				C						Current
				D						Continuous voltage output
				P						Transmitter power supply
				0						None
				0						2 digital inputs (DI-F1/2) *3
				1						10 digital inputs *4
				2						2 digital inputs + 8 digital outputs *3
				3						2 digital inputs + 8 digital outputs + RS-485 communication *3
				4						2 CT inputs *5
				5						2 CT inputs + 8 digital inputs *5
				6						2 CT inputs + 8 digital outputs *5
				7						2 CT inputs + 8 digital outputs + RS-485 communication *5
				0						None
				T						Tropicalization treatment
				K						Anti-sulfide treatment
				D						Inspection certificate
				B						Tropicalization treatment + inspection certificate
				L						Anti-sulfide treatment + inspection certificate
				Y						Complying with the traceability certification
				Z						Tropicalization treatment + Complying with the traceability certification
				X						Anti-sulfide treatment + Complying with the traceability certification
				0						None
				1						LEDs: all orange

\*1: Not available for SDC45V.

\*2: SDC45V only.

\*3: There are no digital inputs if "SS" is selected for Outputs 3, 4.

\*4: There are 8 digital inputs if "SS" is selected for Outputs 3, 4.

\*5: Cannot be selected if "SS" is selected for Outputs 3, 4.

\*6: Available soon.

### ■ SDC46 (with 14-digit model No.)

All models have 2 digital inputs.

Basic model No.	Input model	Power supply	Output 1, 2	Output 3, 4	Output 5	Output 6, 7	Option	Addition 1	Addition 2	Specifications
C46A										Standard model
C46V										Computation function model
	1									1 input (full multiple 1) *1
	2									2 inputs (full multiple 2)
	3									3 inputs (full multiple 1, linear 2) *2
										100 to 240 Vac
										24 Vac/dc *8
										1 form 1a1b relay
										2 form 1a relays
				CO						Current (output 3)
				DO						Continuous voltage output (output 3)
				VO						Voltage pulse (output 3)
				RR						2 form 1a relays
				CC						2 current outputs
				VV						2 voltage pulse outputs
				CV						Current (output 3) + voltage pulse (output 4)
				SS						2 triac + 1 MFB input
				0						None
				R						Form 1a relay *4
				C						Current *4
				D						Continuous voltage output *4
				P						Transmitter power supply *4
				0						None
				1						Current
				2						Transmitter power supply
				3						2 current outputs *3
				4						Current (output 6) + Transmitter power supply (output 7)
				0						2 digital inputs (DI-F1/2) *3
				1						14 digital inputs *4
				2						14 digital inputs + 8 digital outputs *6
				3						2 digital inputs + 8 digital outputs + RS-485 communication *6
				4						2 CT inputs *7
				5						2 CT inputs + 8 digital inputs *7
				6						2 CT inputs + 8 digital outputs *7
				7						2 CT inputs + 8 digital outputs + RS-485 communication *7
				0						None
				T						Tropicalization treatment
				K						Anti-sulfide treatment
				D						Inspection certificate
				B						Tropicalization treatment + inspection certificate
				L						Anti-sulfide treatment + inspection certificate
				Y						Complying with the traceability certification
				Z						Tropicalization treatment + Complying with the traceability certification
				X						Anti-sulfide treatment + Complying with the traceability certification
				0						None
				1						LEDs: all orange

\*1: Not available for SDC46V.

\*2: SDC46V only.

\*3: Not available if "CC" is selected for Outputs 3, 4 and "C" is selected for Output 5.

\*4: Selection must be "0" if "R1" is selected for Outputs 3, 4.

\*5: There are no digital inputs if "SS" or "R1" is selected for Outputs 3, 4.

\*6: There are 12 digital inputs if "SS" or "R1" is selected for Outputs 3, 4.

\*7: Not available if "SS" or "R1" is selected for Outputs 3, 4.

\*8: Available soon.

\* Cannot be selected when "CC" is selected for outputs 3 and 4, and "C" is selected for output 5.

### ■ SDC45A (with 7-digit model No.)

Displays have all-orange LEDs.

Basic model No.	Set No.	Option 1	Option 2	Specifications
C45A				Standard model: Basic model, 2 alarm outputs
	0			None
	0			Regular type 1: 1 current + 2 relay outputs + 2 digital inputs
	1			Regular type 2: 1 current + 1 voltage pulse + 1 relay output + 2 digital inputs
	3			Regular type 3: 2 current outputs + transmitter power supply (24V

## MAINTENANCE

- Cleaning: When removing dirt from the instrument, wipe it off with a soft cloth rag.
- Part replacement: Do not replace any parts of this unit.
- Fuse replacement: When replacing the fuse connected to the electric wiring, always use the specified standard fuse.  
Standard IEC 127  
Shut-down speed Slow-action type (T)  
Rated voltage 250 V  
Rated current 1.0 A
- Battery replacement: Yamatake battery No. 81446345-001.

## SPECIFICATIONS

### ■ PV input

- Thermocouple: K, E, J, T, B, R, S, N (JIS C 1602-1995)  
WRc5-26 (ASTM E988-96 (reapproved 2002)), PR40-20 (ASTM E1751-00), Ni-Ni-Mo (ASTM E1751-00), PL II (ASTM E1751-00), DIN U, DIN L (DIN 43710-1985)  
Gold-iron/chromel (ASTM E1751-00)
- Resistance temperature detector (RTD):  
Pt100 (JIS C 1604-1997)  
JPt100 (JIS C 1604-1989)
- DC voltage (mV range): 0 to 10 mV, -10 to +10 mV, 0 to 100 mV, -100 to +100 mV
- DC voltage (V range): 0 to 1 V, -1 to +1 V, 1 to 5 V, 0 to 5 V, 0 to 10 V
- DC current: 4 to 20 mA, 0 to 20 mA
- Sampling cycle: 25, 50, 100, 300 ms (determined by the sampling cycle setting) (SDC45A/46A)  
100 ms (SDC45V/46V)
- Indication accuracy (under standard conditions)  
Thermocouple:  $\pm 0.1$  % rdg.  $\pm 1$  digit  
(determined by the range and measured temperature)
- Resistance temperature detector(RTD):  $\pm 0.15$  to  $0.3$  °C  
(determined by the range)
- DC voltage • DC current:  $\pm 0.1$  %FS  $\pm 1$  digit
- Input impedance: 110  $\Omega$  or less for current input
- Cold junction compensation accuracy:  
 $\pm 0.5$  °C (standard conditions)  
 $\pm 1.0$  °C (in the 0 to 50 °C ambient temperature range)
- Cold junction compensation method:  
Internal/external (0 °C only) compensation selectable

### ■ Motor feedback input (MFB)

- Allowable potentiometer value:  
100 to 2,500  $\Omega$
- Indication accuracy:  $\pm 0.2$  %FS (standard conditions)
- Sampling cycle: 100 ms

### ■ Current transformer input

- Compatible current transformer:  
QN212A ( $\phi 12,800$  T)  
QN206A ( $\phi 6,800$  T)
- Current measurement range:  
0.0 to 55.0 Aac (Accuracy may be out of specifications for less than 0.4 Aac.)
- Indication accuracy:  $\pm 3$  %FS  $\pm 1$  digit
- Indication resolution: 0.1 Aac
- Input impedance: 10  $\Omega$  (typ)

### ■ External switch input

#### ● Digital input (DI)

- Connectable outputs: Dry contact or transistor (sink type)
- Open terminal voltage: 7 Vdc  $\pm 15$  % \*
- Terminal current (during short-circuit): 3 to 7 mA \*
- Allowable ON contact resistance: 500  $\Omega$  max. \*
- Allowable OFF contact resistance: 100 k $\Omega$  min. \*
- Allowable ON residual voltage: 1.5 V max. \*
- Allowable OFF-state leakage current: 0.1 mA max. \*

\* Under standard conditions.

### ■ Control output (Control output (OUT) • auxiliary output (AUX) • event output (EV))

#### ● Relay output (outputs 1 and 2)

- Contact configuration: 1a1b or 1a, selected by the model No.
- Contact rating: 3A 250 Vac/30 Vdc 1a1b, resistance load  
1A 250 Vac/30 Vdc 1a, resistance load
- Contact voltage: 250 Vac max./125 Vdc max.
- Life: Min. 100,000 operations  
(under rated conditions)
- Min. switching specifications:  
100 mA/5 Vdc 1a1b  
10 mA/5 Vdc 1a

#### ● Relay output (outputs 3, 4 and 5)

- Contact configuration: 1a
- Contact rating: 3 A 250 Vac/30 Vdc (resistance load)
- Contact voltage: 250 Vac max./125 Vdc max.
- Life: Min. 100,000 operations  
(under rated conditions)
- Min. switching specifications:  
100 mA/5 Vdc

#### ● Current output

- Output current: 4 to 20 mAdc(2.4 to 21.6 mAdc)  
0 to 20 mAdc(0.0 to 22.0 mAdc)
- Load resistance: 600  $\Omega$  max.
- Output accuracy:  $\pm 0.1$  %FS max. (standard conditions)
- Output resolution: 1/15000
- Voltage (open): 23 Vdc max.

#### ● Continuous voltage output

- Output current: 0 to 5Vdc (0.0 to 5.5Vdc)  
1 to 5Vdc (0.6 to 5.4Vdc)  
0 to 10Vdc (0.0 to 11.0Vdc)
- Load resistance: 1 k $\Omega$  min.
- Load limit current: 21 mA  
(standard value under standard conditions)
- Output accuracy:  $\pm 0.1$  %FS max. (standard conditions)
- Output resolution: 1/20000 (for 0 to 10V)

#### ● Voltage pulse output

- Output current: 12 Vdc +15 %/-10 %
- Load current: 30 mA max.
- Load limit current: 52 mA  
(standard value under standard conditions)
- OFF-state leakage current:  
0.1 mA max.

#### ● Motor drive output (triac output)

- Contact configuration: 1a
- Compatible motors: ECM3000F1\*\*0  
(100 Vac, relay contact input)

#### ● Transmitter power supply function

- Output current: 24 Vdc  $\pm 10$  %
- Load current: 30 mA max.
- Load limit current: 45 mA  
(standard value under standard conditions)

#### ● Digital output (DO)

- Output type: Transistor (sink type)
- Load voltage: 4.5 to 28 Vdc
- Load current: 70 mA max./point  
500 mA max./unit
- ON-state residual voltage:  
0.5 V max.
- OFF-state leakage current:  
0.1 mA max.

### ■ RS-485 communications

- Transmission line: RS-485, 3 wire multi-drop
- Transmission speed: 4800, 9600, 19200, 38400 bps
- Communication distance:  
500 m max.
- Connectable units: 32 max. (including master station)

Communication system:

Half-duplex, start/stop synchronization

Terminating resistor:

150  $\Omega$  1/2 W, at both ends of the line

Bit length: 8 bits/7 bits

Stop bit length: 1 or 2 bits

Parity bit: Even parity, odd parity, or no parity

Communication protocol:

CPL

### ■ Environmental conditions

#### ● Standard conditions

- Ambient temperature:  $23 \pm 2$  °C
- Ambient humidity:  $60 \pm 5$  %RH
- Rated power supply voltage:  
105 Vac  $\pm 1$  %
- Power frequency:  $50 \pm 1$  Hz or  $60 \pm 1$  Hz
- Vibration resistance: 0 m/s<sup>2</sup>
- Shock resistance: 0 m/s<sup>2</sup>
- Mounting angle: Reference plane  $\pm 3$  °

#### ● Operating conditions

- Ambient temperature: 0 to 50 °C
- Ambient humidity: 10 to 90 %RH (without condensation)
- Rated power supply voltage:  
85 to 264 Vac
- Power frequency:  $50 \pm 2$  Hz or  $60 \pm 2$  Hz
- Vibration resistance: 0 to 2 m/s<sup>2</sup> (10 to 60 Hz for 2 h each in X, Y, and Z directions)
- Shock resistance: 0 to 10 m/s<sup>2</sup>
- Mounting angle: Reference plane  $\pm 10$  °
- Altitude: 2000 m max.

#### ● Transportation conditions

- Ambient temperature: -20 to +70 °C
- Ambient humidity: 10 to 95%RH (without condensation)
- Vibration resistance: 0 to 5 m/s<sup>2</sup> (10 to 60 Hz for 2 h each in X, Y, and Z directions)
- Shock resistance: 0 to 500 m/s<sup>2</sup>  
(3 times each in X, Y, and Z directions)

### ■ Other specifications

- Power consumption: 30 VA max. (SDC45)  
40 VA max. (SDC46)
- Power ON inrush current:  
35 A max./10 ms max.
- Allowable transient power loss:  
20 ms min.
- Mass: Approx. 400g (SDC45, including dedicated mounting bracket)  
Approx. 700g (SDC46, including dedicated mounting bracket)
- Terminal screw tightening torque:  
0.4 to 0.6 N•m
- Protection: IP65 (under operating conditions)
- Standards compliance:  
EN61010-1, EN61326
- Overvoltage category:  
Category II  
(IEC60364-4-443, IEC60664-1)
- Allowable pollution degree:  
Pollution degree 2

## OPTIONAL PARTS LIST

Item	Parts No. or model No.
Mounting bracket (2 units)	81405411-003
Terminal cover *	81441420-001
Battery	81446345-001
Current transformer	QN212A ( $\phi 12$ )
	QN206A ( $\phi 6$ )

\* 1 cover for SDC45, 2 for SDC46.

**azbil**

Specifications are subject to change without notice.

Yamatake Corporation  
Advanced Automation Company

1-12-2 Kawana, Fujisawa  
Kanagawa 251-8522 Japan

URL: <http://www.azbil.com>

Printed on recycled paper. (07)

Printed in Japan.  
1st Edition: Issued in Nov. 2007 (W)

# Flowchart of key operations and displays

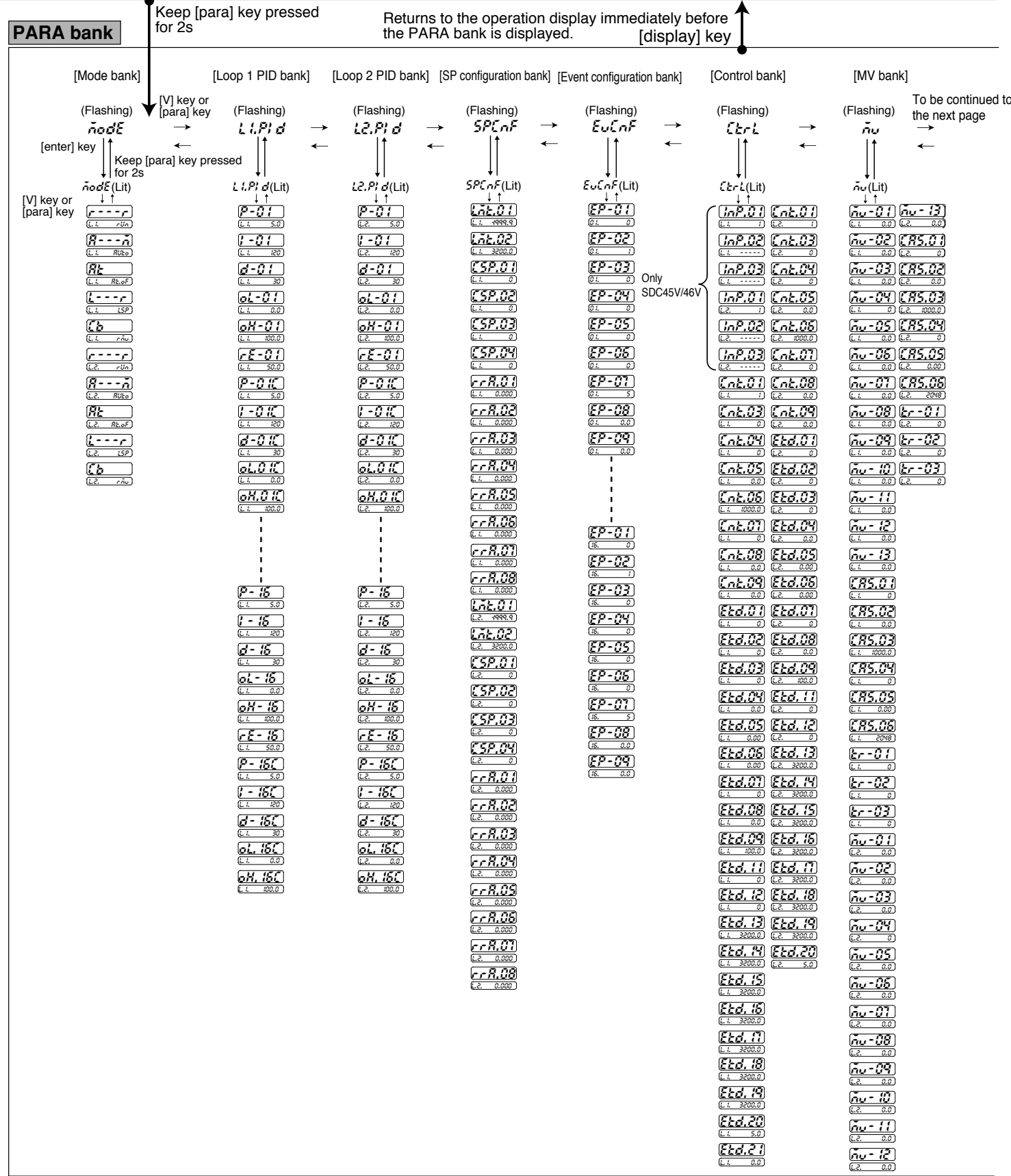
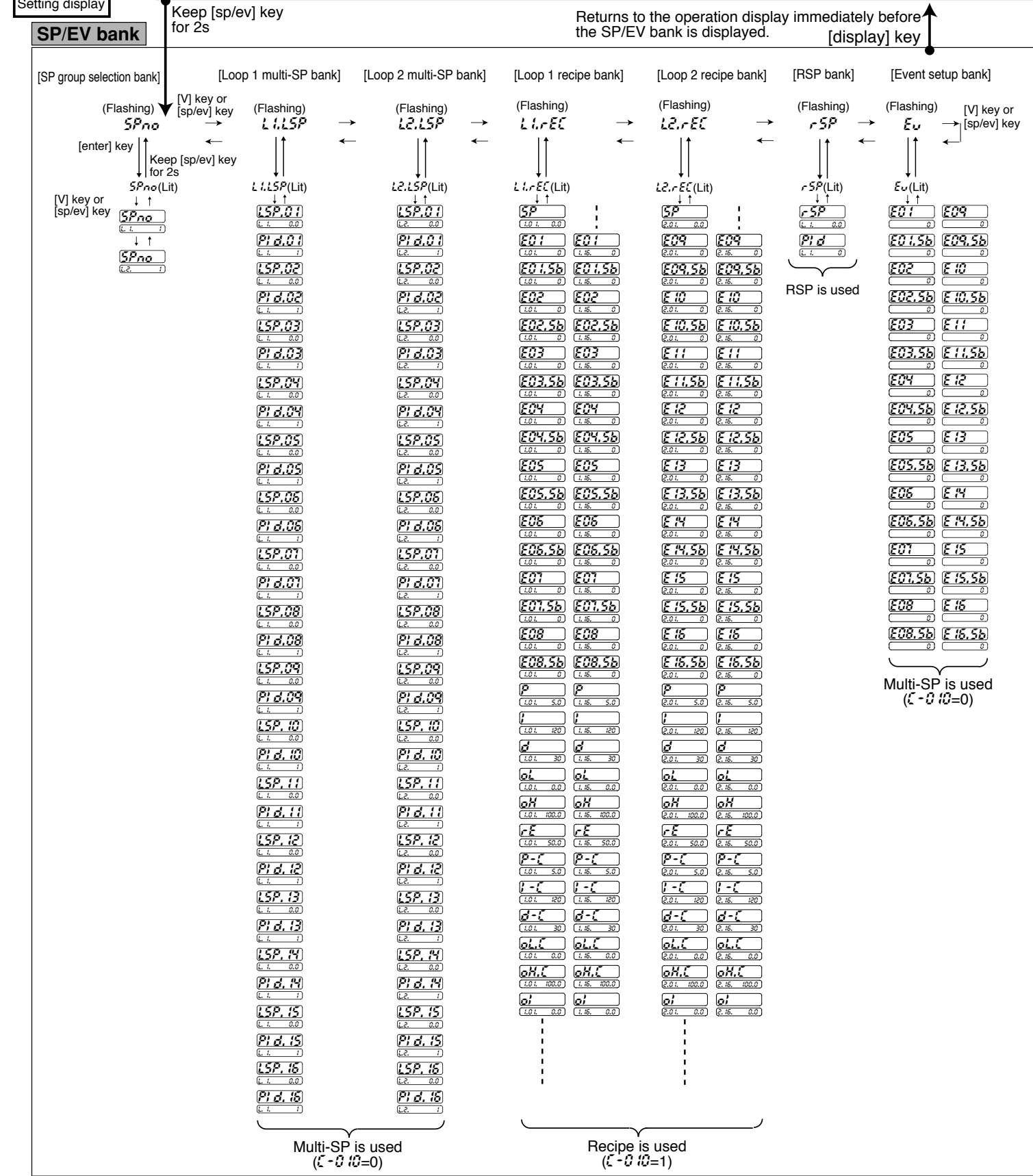
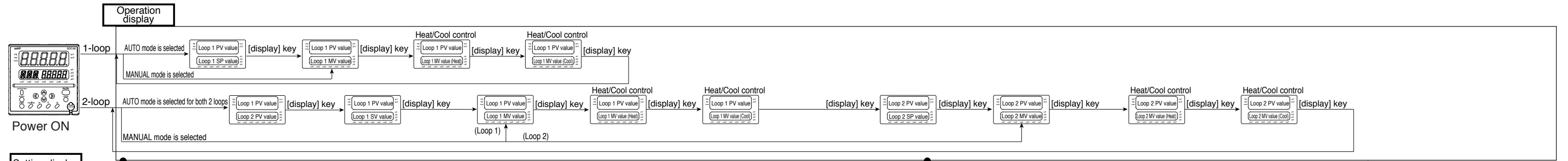

■ Movement within bank

- Forward movement  
[sp/ev] key or [V] key (SP/EV bank)  
[para] key or [V] key (PARA bank)
- Backward movement  
[Λ] key

Return to the operation display immediately before the PARA bank is displayed

**PARA bank**

[display] key

