

# DigitroniK Line SDC40A Digital Indicating Controller User's Manual

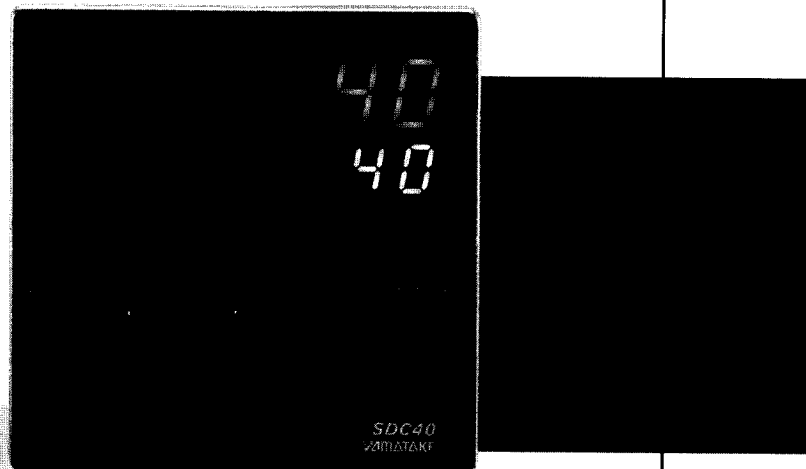

Thank you for purchasing the SDC40A. This manual contains information for ensuring correct use of the the SDC40A. It also provides necessary information for installation, maintenance, and troubleshooting.

This manual should be read by those who design and maintain devices that use the the SDC40A.

Be sure to keep this manual near by for handy reference.

Yamatake Corporation

## **RESTRICTIONS ON USE**

When using this product in applications that require particular safety or when using this product in important facilities, pay attention to the safety of the overall system and equipment. For example, install fail-safe mechanisms, carry out redundancy checks and periodic inspections, and adopt other appropriate safety measures as required.

## **REQUEST**

Make sure that this Instruction Manual is handed over to the user before the product is used.

Copying or duplicating this Instruction Manual in part or in whole is forbidden. The information and specifications in this Instruction Manual are subject to change without notice.

Considerable effort has been made to ensure that this Instruction Manual is free from inaccuracies and omissions.

If you should find any inaccuracies or omissions, please contact Yamatake Corporation.

In no event is Yamatake Corporation liable to anyone for any indirect, special or consequential damages as a result of using this product.

**© 1994 Yamatake Corporation ALL RIGHTS RESERVED**

The above is a trademark of Yamatake Corporation.

# ———— CONTENTS ————

## **Chapter 1 NAMES AND FUNCTIONS OF COMPONENT PARTS**

1-1	Introduction .....	1-1
1-2	Basic Function Block Diagram .....	1-2
1-3	Names and Functions of Indicators on Console .....	1-4
1-4	Names and Functions of Keys on Console .....	1-5
1-5	Model Selection Guide .....	1-6
1-6	Input Types and Range Numbers .....	1-7

## **Chapter 2 INSTALLATION**

2-1	External Dimensions .....	2-1
2-2	Panel Cutout Size .....	2-2
2-3	Mounting .....	2-3

## **Chapter 3 WIRING**

3-1	Cables .....	3-1
3-2	Terminal Connections .....	3-2
3-3	Terminal Arrangement and Recommended Direction of Wire Draw-out .....	3-2
3-4	Power Supply Connections .....	3-3
3-5	Grounding .....	3-3
3-6	Terminal Connection Diagrams of Standard and Extension Terminal Bases .....	3-4
3-7	Input 1 (PV1) Connection .....	3-5
3-8	Input 2 (PV2/RSP) Connection .....	3-5
3-9	Control Output Connection .....	3-6
3-10	Connection of Auxiliary Output 1, 2 (option) .....	3-8
3-11	Connection of Relay Event Output .....	3-8
3-12	Connection of Open Collector Event Output (option) .....	3-9
3-13	Connection of Remote Switch Input (option) .....	3-9
3-14	Communication (option) Connection .....	3-10
3-15	Wiring Precautions .....	3-13

3-16	Noise .....	3-13
	1. Noise generation sources	
	2. Measures for noise suppression	
3-17	Isolation between Input and Output .....	3-14
<b>Chapter 4</b>	<b>OUTLINE OF SETTING</b>	
4-1	Initialize .....	4-1
4-2	Major Setup Items (block diagram) .....	4-1
<b>Chapter 5</b>	<b>SETTING OF PARAMETER (PARA) ITEMS</b>	
5-1	Parameter Operation .....	5-1
5-2	Parameter Item Table .....	5-3
5-3	Detailed Description of Parameter Items .....	5-10
<b>Chapter 6</b>	<b>SETTING OF PID ITEMS</b>	
6-1	PID Operation .....	6-1
6-2	PID Item Table .....	6-3
6-3	Detailed Description of PID Items .....	6-4
<b>Chapter 7</b>	<b>SETTING OF SETUP ITEMS</b>	
7-1	Setup Operation .....	7-1
7-2	Setup Item Table .....	7-3
7-3	Detailed Description of Setup Items .....	7-15
<b>Chapter 8</b>	<b>USER FUNCTION KEYS UF1 AND UF2</b>	
8-1	How to Use the User Function Keys .....	8-1
8-2	How to Register a Function in User Function Key .....	8-2
<b>Chapter 9</b>	<b>OPERATION</b>	
9-1	Power ON .....	9-1
9-2	Indication Changeover .....	9-1
9-3	Setting of SP and SP Number .....	9-5
9-4	EV Setting .....	9-10

**Chapter 10 TROUBLESHOOTING**

10-1 Alarm Indication .....	10-1
10-2 When SETUP after C2 cannot be changed. ....	10-2
10-3 When RUN/READY cannot be selected by key operation. ....	10-2
10-4 When the control output is not obtained normally. ....	10-2
10-5 When the computer backup function is not activated normally. ....	10-2
10-6 When the motor cannot be adjusted. ....	10-3

**Chapter 11 SPECIFICATION**



# Chapter 1 NAMES AND FUNCTIONS OF COMPONENT PARTS

## 1-1 Introduction

The DIGITRONIK SDC40A is a general-purpose indicating controller for controlling the temperature, pressure, flowrate, pH, liquid level and others.

The SDC40A features a wide variety of input options; thermocouples, resistance thermometer bulbs, DC voltage and DC current inputs are supported. Control actions are also provided with such superb functions that not only two-freedom degree PID, but also tuning by neural net and smart tuning for suppressing overshoot can be selected optionally. Therefore, the SDC40A can be used for a variety of applications, making the best of the following features.

### Features

- High accuracy and high resolution : Accuracy of  $\pm 0.1\%$  FS, sampling cycle of 0.1 sec, and high resolution display of 5 digits. Stable high-resolution control actions can be realized.
- Instensified correspondence to PLC : Flexibly corresponds to automatic operation in combination with a PLC, providing a maximum of 12 remote switch inputs and a maximum of 8 event outputs.
- Coping with system down : The instrument cannot only back up a PLC, computer or the like used as a center of automation, but also can cope with system down more quickly with the monitoring functions of sensors or operation terminals strengthened.
- Correspondence to various controls : Flexibly corresponds to various controls of temperature, pressure, flowrate, level, pH and others by the variable gain, input broken line approximation, multi ratio setting, internal cascade functions, and others.
- Simple operation : The operation levels are classified into two; short time setup by the smart handy loader is provided for an engineer, while simple setting by the user function keys is provided for an operator.

### Configuration

This instrument consists of a console, main body, standard terminal base, and extension terminal base (option).

- Console : 7-segment display, LEDs and various operation keys
- Main body : Case and others
- Standard terminal base : Terminals for connecting the power supply, sensors and others.
- Extension terminal base: Terminals for connecting communication signals, event outputs and remote switches used as option.

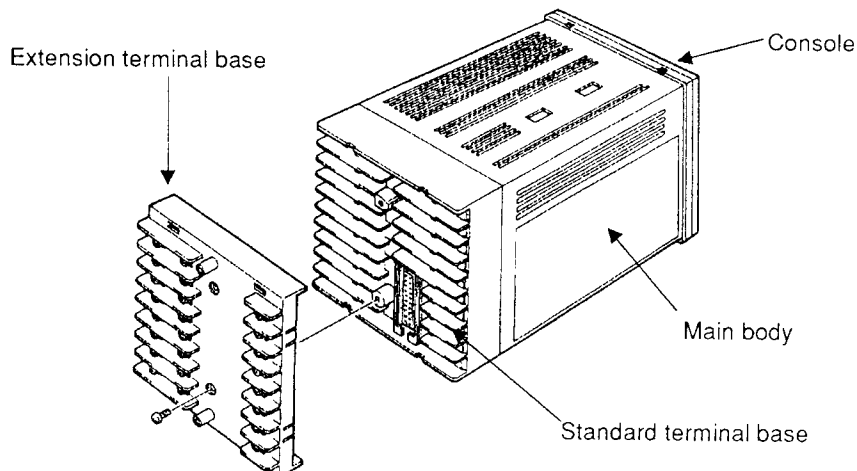

**1-2 Basic Function Block Diagram**

- **Standard Model and Remote SP Model** (★: Optional function)

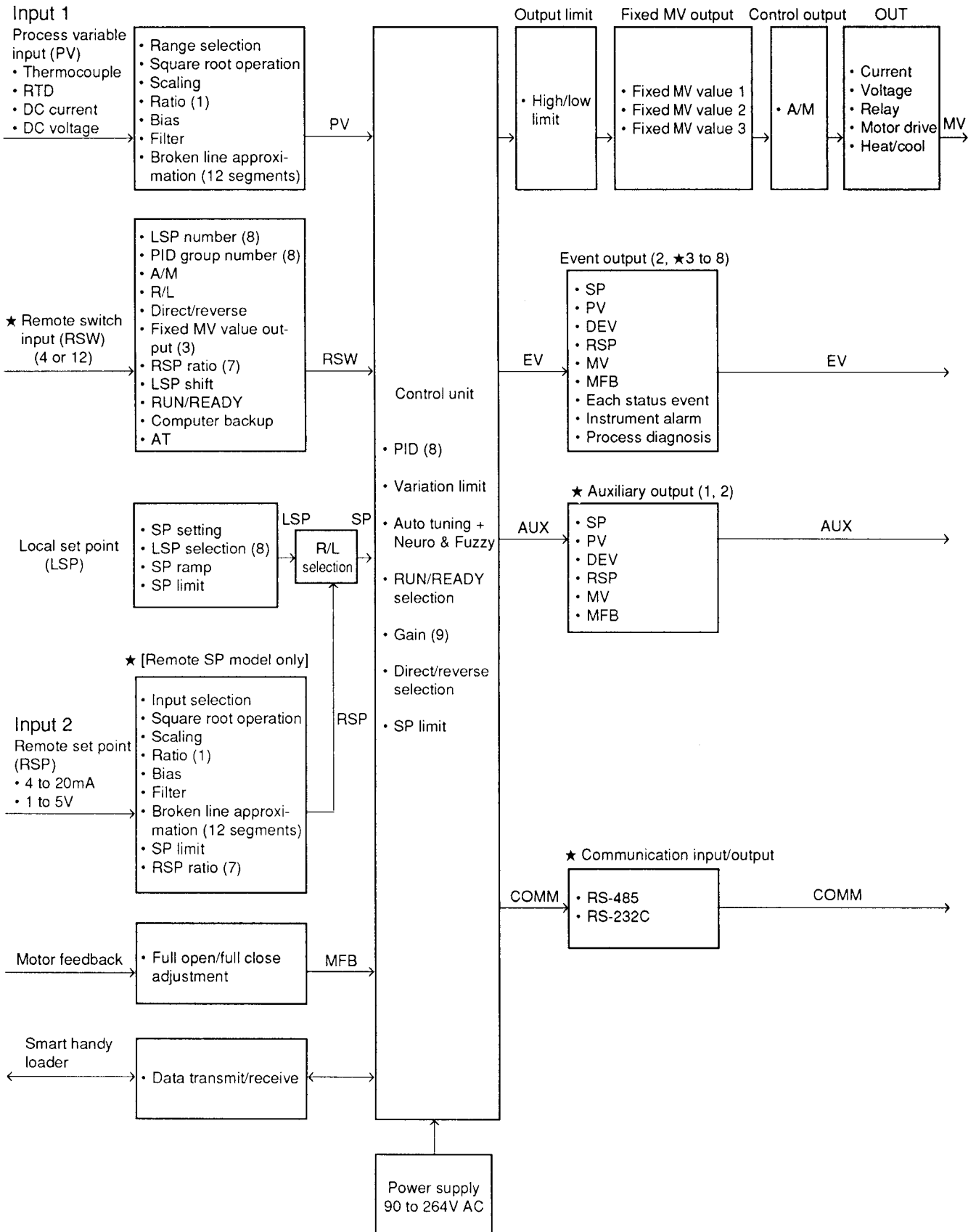

• Internal Cascade Model (★: Optional function)

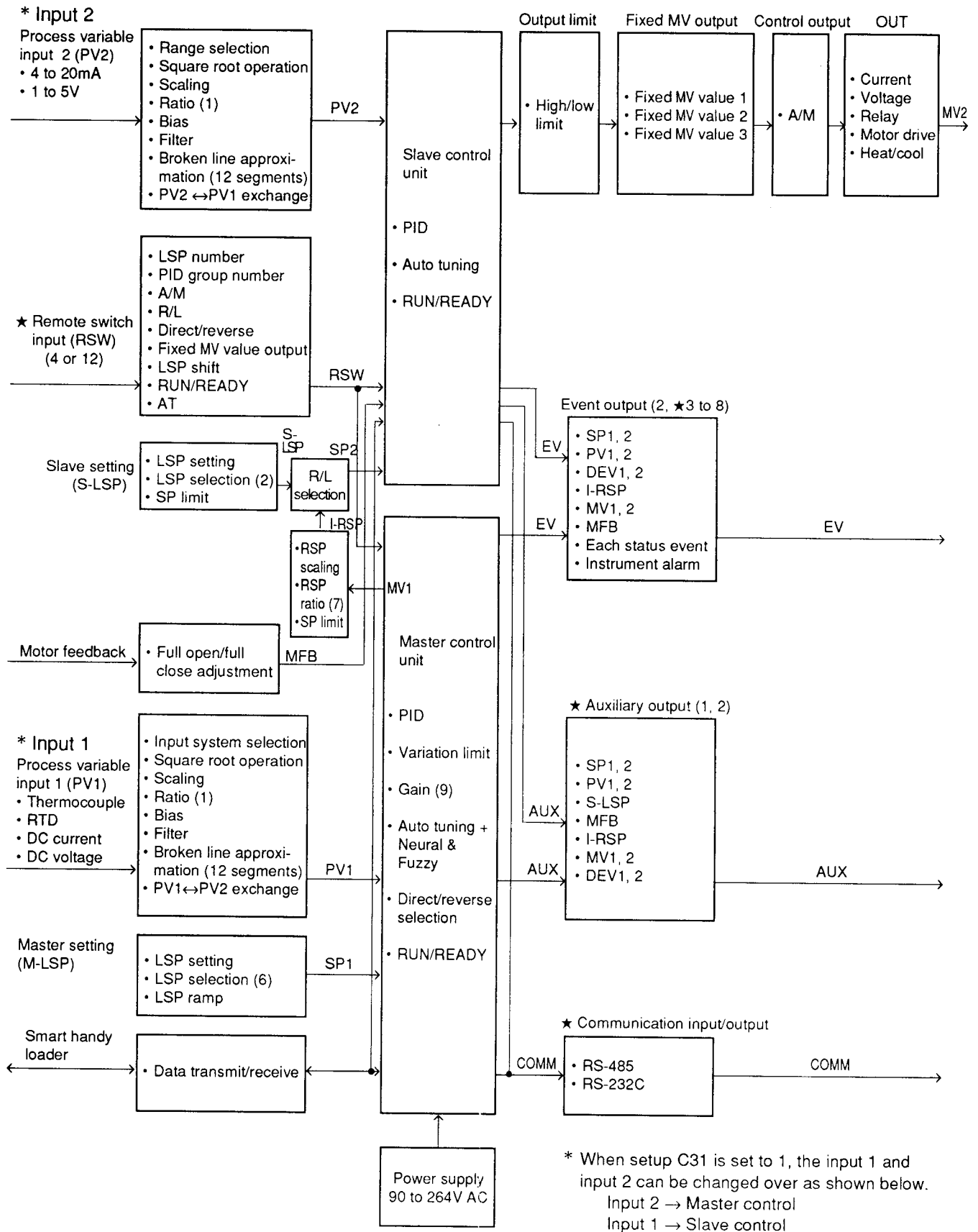

### 1-3 Names and Functions of Indicators on Console

The console consists of keys, indicators and LEDs (light-emitting diode lamps) to permit various operations to be done.

**Channel LED**

Indicates the channel number of a PV being indicated currently. (Lights only in internal cascade model.)  
 CH1 : PV1 of input 1  
 CH2 : PV2 of input 2

**Mode LEDs**

Indicates the operation mode of the instrument.  
**RDY (READY)**  
 : Lights in READY mode, and goes out in RUN mode.  
**REM (REMOTE)**  
 : Lights when remote set input RSP is applied, and goes out when local set input LSP is applied.  
**MAN (MANUAL)**  
 : Lights in manual operation, and goes out in AUTO operation.  
**COM (COMMUNICATION)**  
 : Lights when the communication line is used.

**No.3 indicator**

An auxiliary indicator which indicates the group number of an SP, and can also indicate the item number of a parameter, etc.

**OUT LED**

Lights when a control output value when is indicated in a bar graph.

**EV1, 2, 3**

The relevant LED lights when a relay event output is turned on.

**No.1 indicator**

Indicates a PV value (measured temperature) usually and can also indicate the contents of parameters, etc.

**No.2 indicator**

Indicates an SP (set temperature) and can also indicate the numerics of parameters, etc. or can also indicate a deviation, manipulated variable, etc. selectively.

**Bar graph indicator**

Indicates the control output in percentage as a bar graph facing sideways, and can also be used as a green belt, remote switch monitor or event monitor to indicate a control condition.

**UF (User Function) LED**

LED lamp whose lighting condition can be set by a user.

**AT (Auto Tuning) LED**

Flashes when the instrument is placed in the auto tuning mode, and lights when it is placed in the smart tuning mode.

**OT1, 2 control output status LED**

The relevant LED lights when a control output is turned on.

**No.2 indicator contents LEDs**

Indicates the contents of the value indicated in No. 2 indicator.  
 SP (Set Point) : Lights when the set temperature is indicated.  
 DEV (Deviation) : Lights when a deviation (PV - SP) is indicated.  
 OUT (Output) : Lights when the control output is indicated.

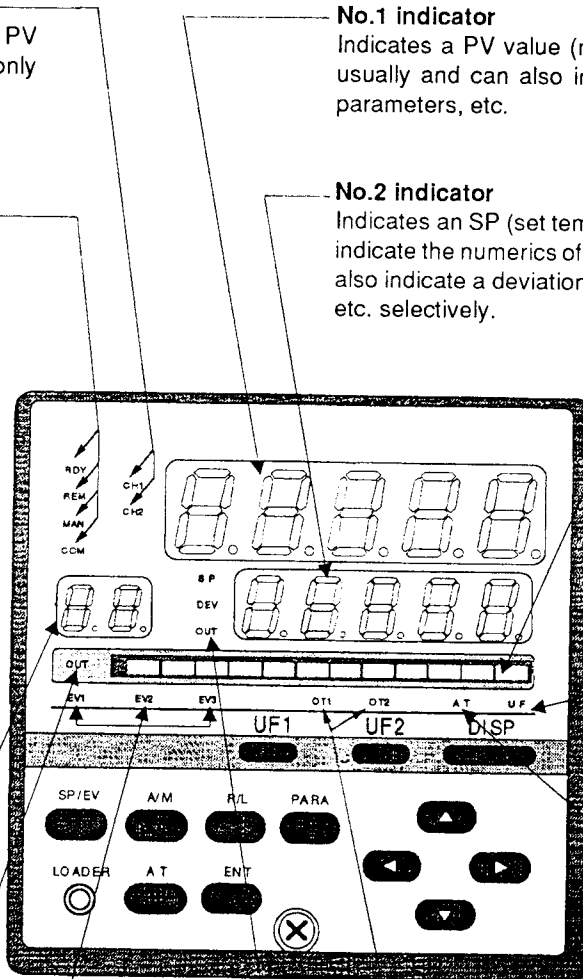

**1-4 Names and Functions of Keys on Console**

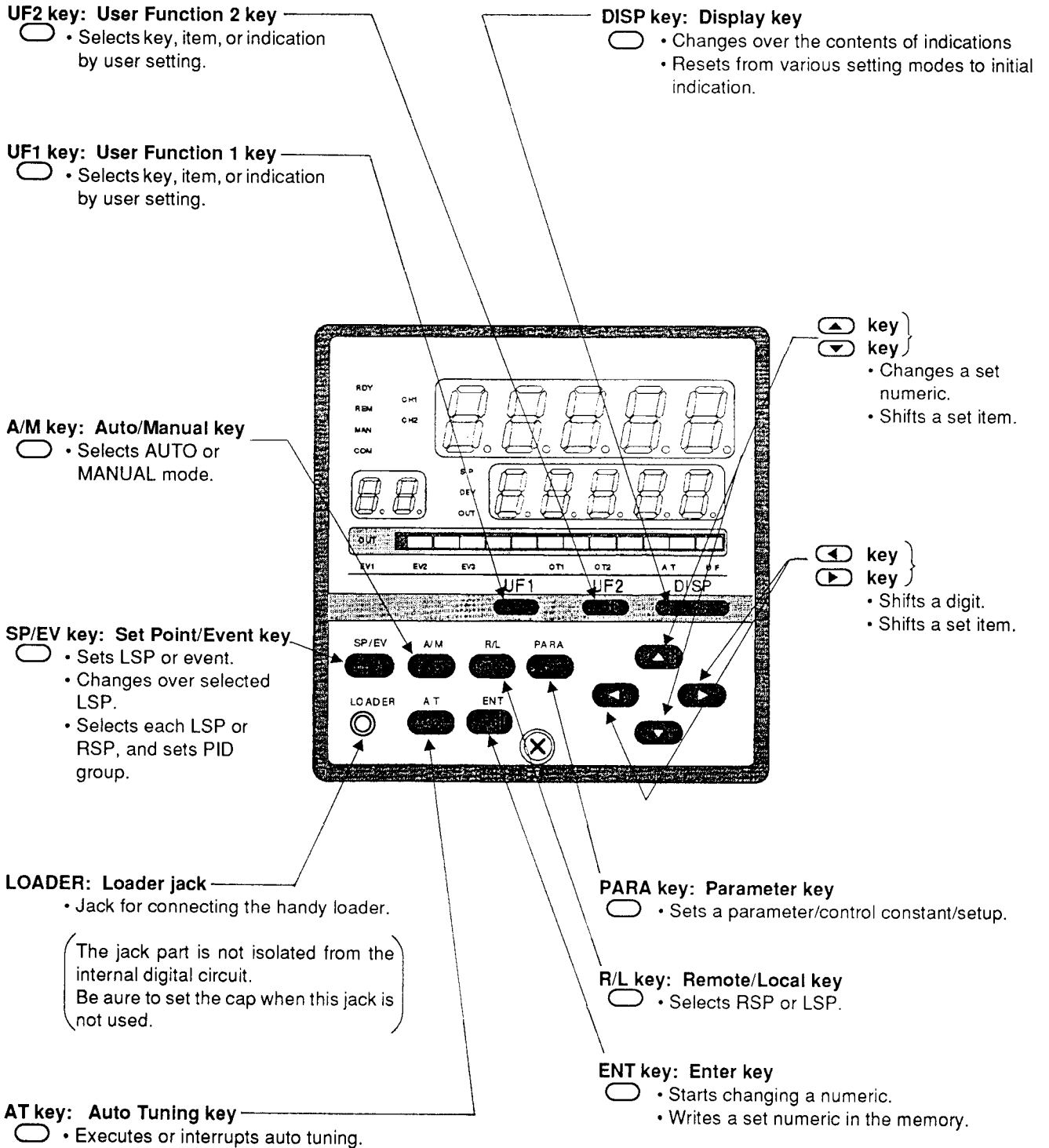

**1-5 Model Selection Guide: Example C40A5G0AS04100**

Basic Model No.	Control output	Function	Power supply	Option 1	Option 2	Additional processing	Description
C40A							Digital indicating controller
	0D						Relay output (on-off or time proportional)
	6D						Voltage output (with current value adjusting function)
	2G						Position proportional output
	5G						Current output (4 to 20mA)
	3D						Heat/cool control, relay output + relay output
	AK						Heat/cool control, relay output + current output
	5K						Heat/cool control, current output + current output
	9K						Heat/cool control, relay output + voltage output
	BK						Heat/cool control, current output + voltage output
		0					Standard model
		1					Remote SP function model
		2					Internal cascade function model
			AS				Free power supply voltage
				00			Option 1 is not provided with (2 points of SPST relay contact output provided).
				01			With 4 points of remote switching
				02			With 1 added point of SPDT relay contact event output
				03			With 4 points of remote switching + 1 added point of SPDT relay contact event output
				04			With 4 points of remote switching + 1 point of auxiliary output
				05			With 1 added point of event output + 1 point of auxiliary output
				06			With 4 points of remote switching + 1 added point of SPDT relay contact event output + 1 point of auxiliary output
				07			With 4 points of remote switching + 2 points of auxiliary output
				08			With 1 added point of event output + 2 points of auxiliary output
				09			With 4 points of remote switching + 1 added point of SPDT relay contact event output + 2 points of auxiliary output
					0		Option 2 is not provided. (If option 1 is not designated, 0 will be selected without fail.)
					1		With 8 added points of remote switching + 5 added points of event output (open collector output)
					2		With 8 added points of remote switching + 5 added points of event output (open collector output) + RS-485 communication
					3		With 8 added points of remote switching + 5 added points of event output (open collector output) + RS-232C communication
					00		Additional processing not provided.
					T0		Tropicalization treatment applied
					K0		Antisulfidation corrosion treatment applied
					D0		Data attached
					B0		Tropicalization treatment applied + data attached
					L0		Antisulfidation corrosion treatment applied + data attached

**Notes:**

The two auxiliary output points of option 1 cannot be specified for the following control outputs. 2G, 3D, AK, 5K, 9K, B

Any of 1 to 3 of option 2 can be selected only when four points of remote switching are provided in option 1 (01, 03, 04, 06, 07, 09).

Selection guide table  
 ○ : Combination possible.  
 × : Combination not possible.

Option 2 \ Option 1	0	1	2	3
00	○	×	×	×
01	○	○	○	○
02	○	×	×	×
03	○	○	○	○
04	○	○	○	○
05	○	×	×	×
06	○	○	○	○
07	○	○	○	○
08	○	×	×	×
09	○	○	○	○

**Note:**

If any of 1 to 3 of option 2 are selected, the extension terminal base is provided.

## 1-6 Input Types and Range Numbers

Input typ	Range number	Code	°C range (°C)	°F range (°F)
K (CA)	0	K09	0.0 to 1200.0	0 to 2400
K (CA)	1	K08	0.0 to 800.0	0 to 1600
K (CA)	2	K04	0.0 to 400.0	0 to 750
K (CA)	3	K29	-200.0 to +1200.0	-300 to +2400
K (CA)	4	K44	-200.0 to +300.0	-300 to +700
K (CA)	5	K46	-200.0 to +200.0	-200 to +400
E (CRC)	6	E08	0.0 to 800.0	0 to 1800
J (IC)	7	J08	0.0 to 800.0	0 to 1600
T (CC)	8	T44	-200.0 to +300.0	-300 to +700
B (PR30-6)	9	B18	0.0 to 1800.0	0 to 3300
R (PR13)	10	R16	0.0 to 1600.0	0 to 3100
S (PR10)	11	S16	0.0 to 1600.0	0 to 3100
W (WRe5-26)	12	W23	0.0 to 2300.0	0 to 4200
W (WRe5-26)	13	W14	0.0 to 1400.0	0 to 2552
PR40-20	14	D19	0.0 to 1900.0	0 to 3400
Ni-Ni · Mo	15	Z13	0.0 to 1300.0	32 to 2372
N	16	U13	0.0 to 1300.0	32 to 2372
PL II	17	Y13	0.0 to 1300.0	32 to 2372
DIN U	18	Z08	-200.0 to +400.0	-300 to +750
DIN L	19	Z07	-200.0 to +800.0	-300 to +1600
Gold iron-chromel	20	Z06	0.0 to 300.0 K	——

Input typ	Range number	Code	°C range (°C)	°F range (°F)
JIS '89 Pt100 (IEC Pt100Ω)	32	F50	-200.0 to +500.0	-300.0 to +900.0
	33	F46	-200.0 to +200.0	-300.0 to +400.0
	34	F32	-100.0 to +150.0	-150.0 to +300.0
	35	F36	-50.0 to +200.0	-50.0 to +400.0
	36	F38	-60.00 to +40.00	-76.00 to +104.00
	37	F33	-40.00 to +60.00	-40.00 to +140.00
	38	F05	0.0 to 500.0	0.0 to 900.0
	39	F03	0.0 to 300.0	0.0 to 500.0
	40	F01	0.00 to 100.00	0.00 to 200.00
JIS '89 JPt100	48	P50	-200.0 to +500.0	-300.0 to +900.0
	49	P46	-200.0 to +200.0	-300.0 to +400.0
	50	P32	-100.0 to +150.0	-150.0 to +300.0
	51	P36	-50.0 to +200.0	-50.0 to +400.0
	52	P38	-60.00 to +40.00	-76.00 to +104.00
	53	P33	-40.00 to +60.00	-40.00 to +140.00
	54	P05	0.0 to 500.0	0.0 to 900.0
	55	P03	0.0 to 300.0	0.0 to 500.0
	56	P01	0.00 to 100.00	0.00 to 200.00

Input typ	Range number	Code	Range (programmable)
4 to 20mA	64	C01	-19999 to 26000
0 to 20mA	65	C08	
0 to 10mV	66	M01	
-10 to 10mV	67	L02	
0 to 100mV	68	L01	
0 to 1V	69	L04	
-1 to 1V	70	L08	
1 to 5V	71	V01	
0 to 5V	72	L05	
0 to 10V	73	L07	

# Chapter 2 INSTALLATION

## 2-1 External Dimensions

Unit: mm

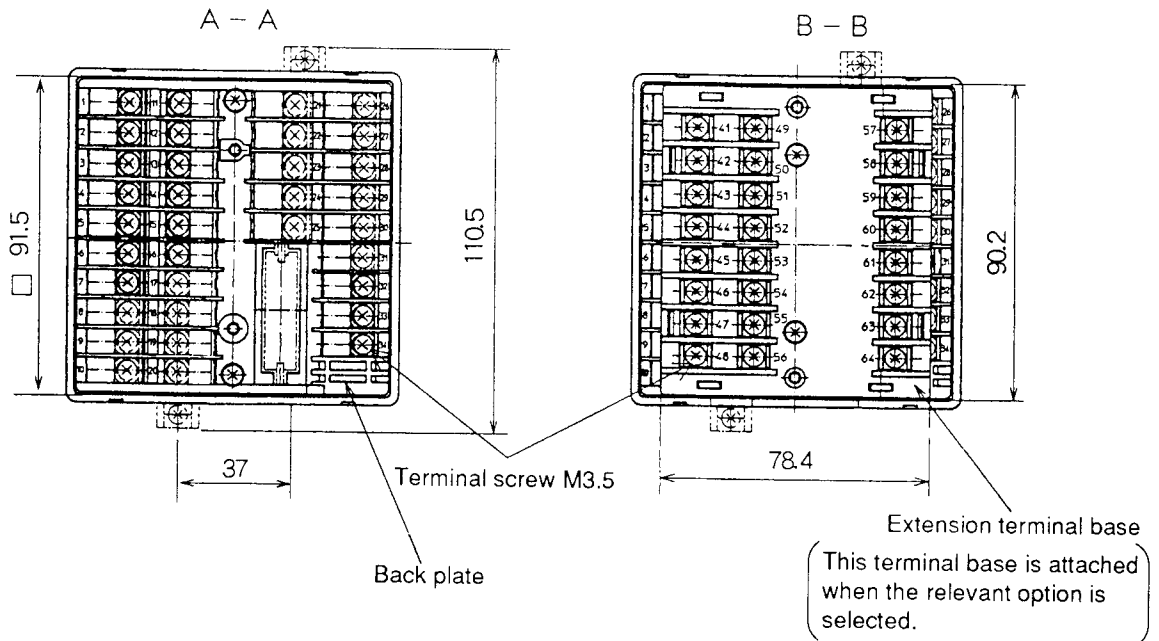
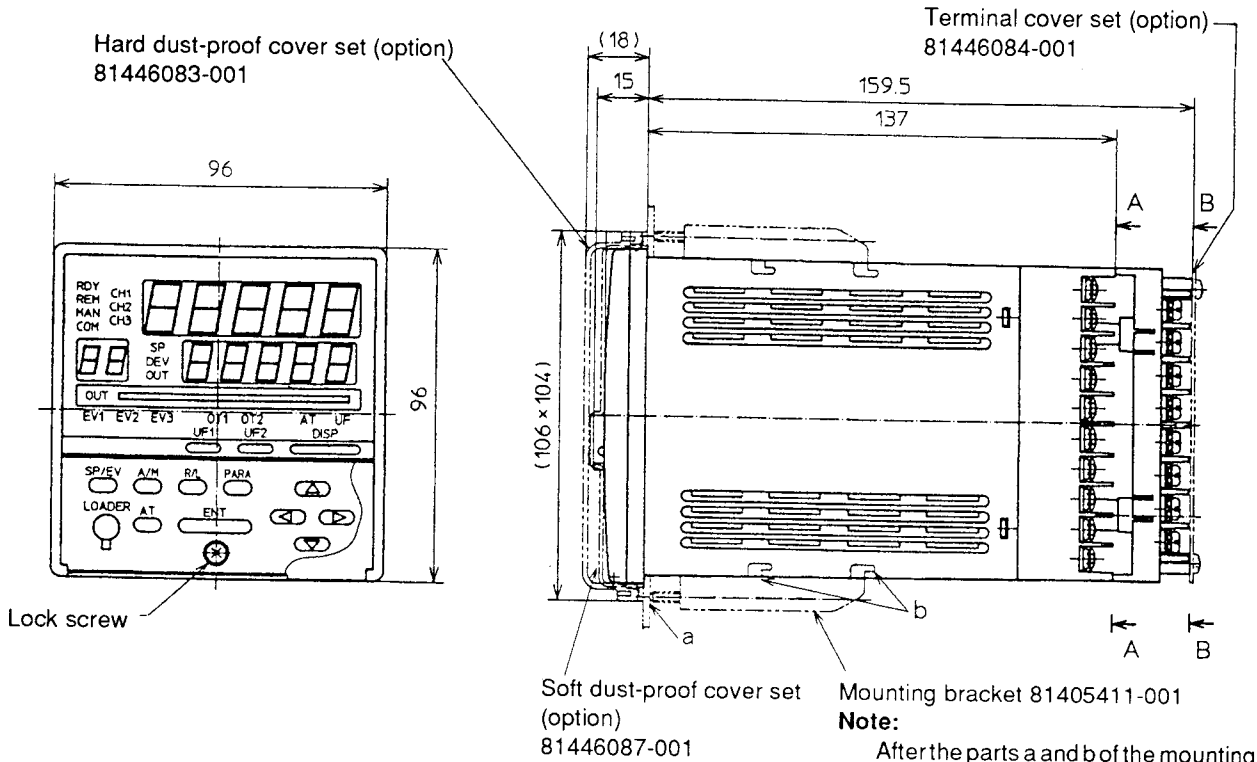

**2-2 Panel Cutout Size**

Unit: mm

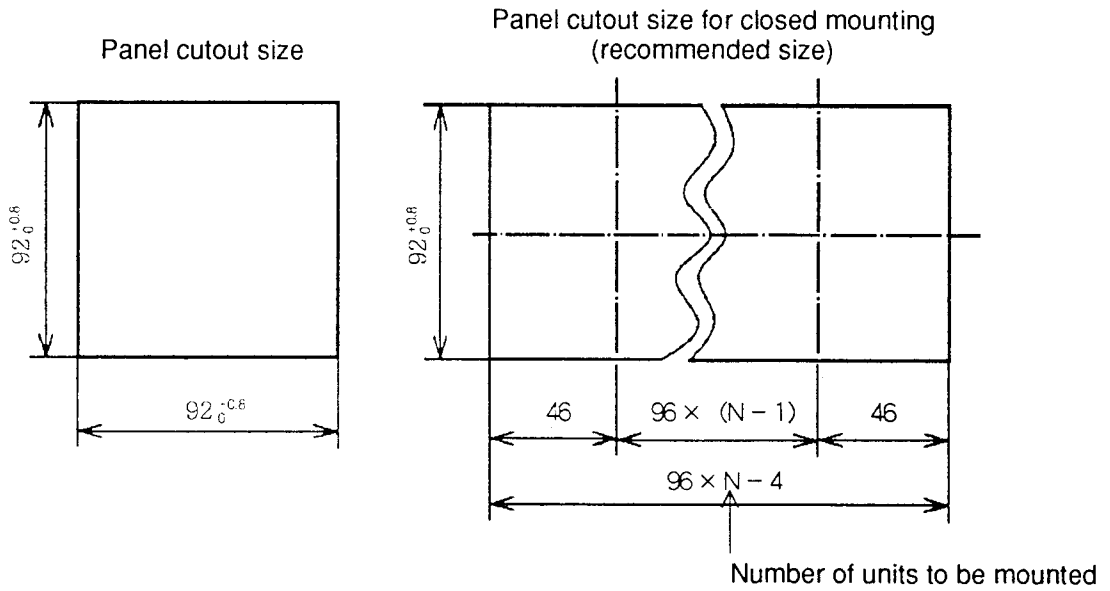

**Panel cutout size (recommended) with vertical and horizontal mounting**

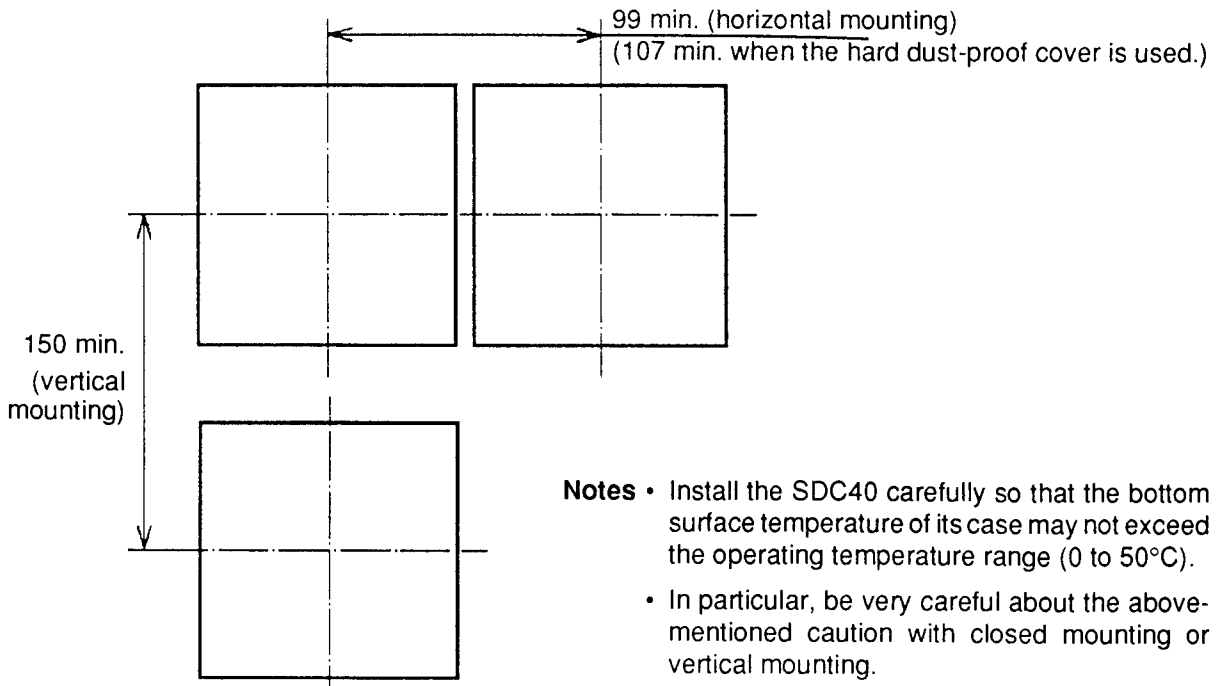

## 2-3 Mounting

### 1. Location of mounting

Mount the instrument at a location which satisfies the following conditions.

- Mount the instrument in locations: Not subject to high or low temperatures, or high or low humidity.
- Free of corrosive gas (sulfide gas, etc.)
- Free of dust particles, soot, or the like
- Not exposed to direct sunlight or the weather
- Free of mechanical vibrations
- Do not mount instrument near a high-tension line, a welder, or electrical noise generating sources.
- Make sure the instrument is more than 15 meters from a boiler or other high-voltage ignition devices.
- The location should not be subject to a strong magnetic field.

### 2. Mounting method

- Mount the instrument before mounting the lower mounting bracket ①.
- After the parts a and b of the mounting fixture touch the mates (after looseness is eliminated at the front and back of the mounting bracket), tighten the screws by about one turn. Be careful since the case may be deformed by tightening the screws excessively.

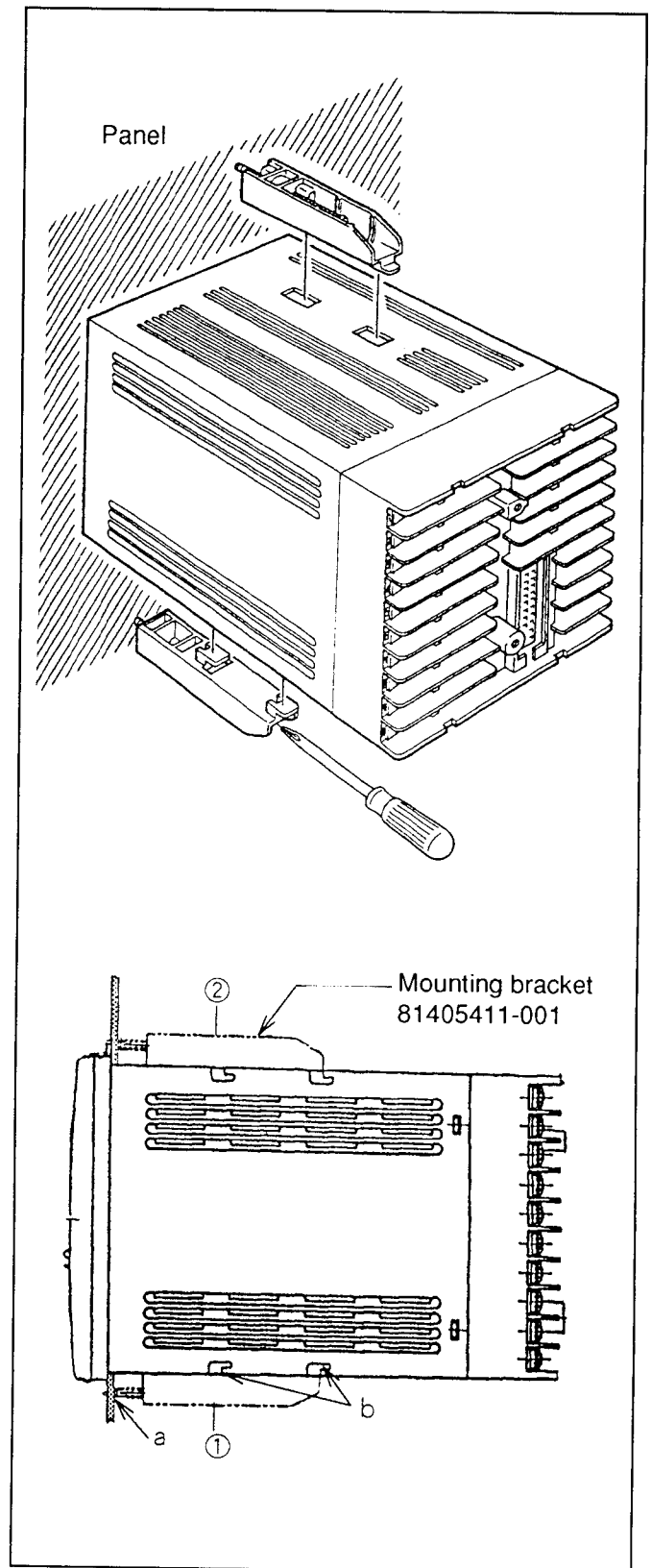

Mounting method (SDC40)

## Installation

- Mount the instrument so that it does not tilt horizontally more than  $10^\circ$  (+ or -).
- Use a steel panel with a plate thickness of more than 2mm.
- Fix the upper and lower panels of the instrument securely by using the attached mounting brackets.

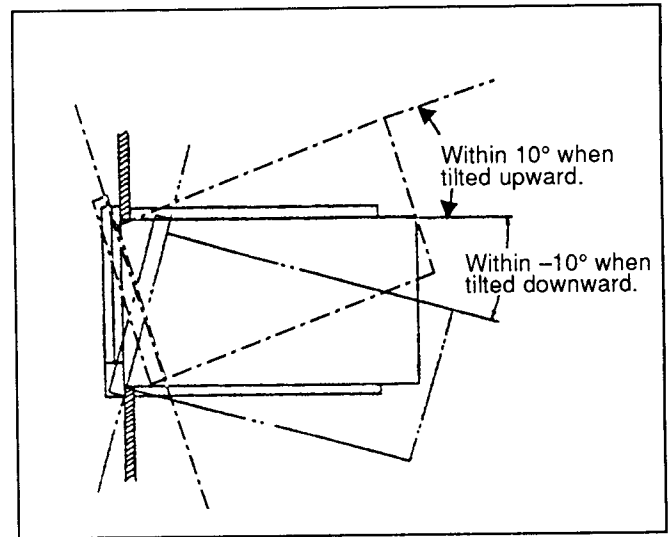

**Mounting angle**

## Chapter 3 WIRING

### 3-1 Cables

Connect thermocouple wires to the terminals in case of a thermocouple input. When a thermocouple is connected to terminals, or wiring distance is long, connect the wires via a shielded compensating lead wire.

- For input/output other than thermocouples, use a shielded polyethylene insulated vinyl sheathed cable for instrumentation use conforming to JCS-364 or equivalent (generally called twisted shielded cable for instrumentation use).
- A shielded multiconductor microphone cord (MVVS) may be used, if electromagnetic induction noise are comparatively low.

**Reference** Recommended twisted shielded cables

Fujikura Cable Co.	2 conductors	IPEV-S-0.9mm <sup>2</sup> x 1P
	3 conductors	ITEV-S-0.9mm <sup>2</sup> x 1T
Hitachi Cable Co.	2 conductors	KPEV-S-0.9mm <sup>2</sup> x 1P
	3 conductors	KTEV-S-0.9mm <sup>2</sup> x 1T

### 3-2 Terminal Connections

Use a crimped style solderless terminal compatible with M3.5 screw.

Caution 1 : Be sure to use round crimped style solderless terminals to prevent disconnection from terminals, if the instrument is mounted at a place subject to noticeable vibrations or impacts.

Caution 2 : Be careful not to allow any crimp style solderless terminals to touch adjacent terminals.

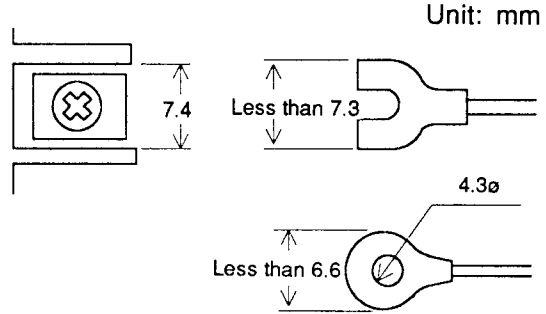

### 3-3 Terminal Arrangement and Recommended Direction of Wire Draw-out

Recommended directions of wire draw-out from the standard terminal base

(Be sure to follow this rule as to the direction of wire draw-out when using the extension terminal base.)

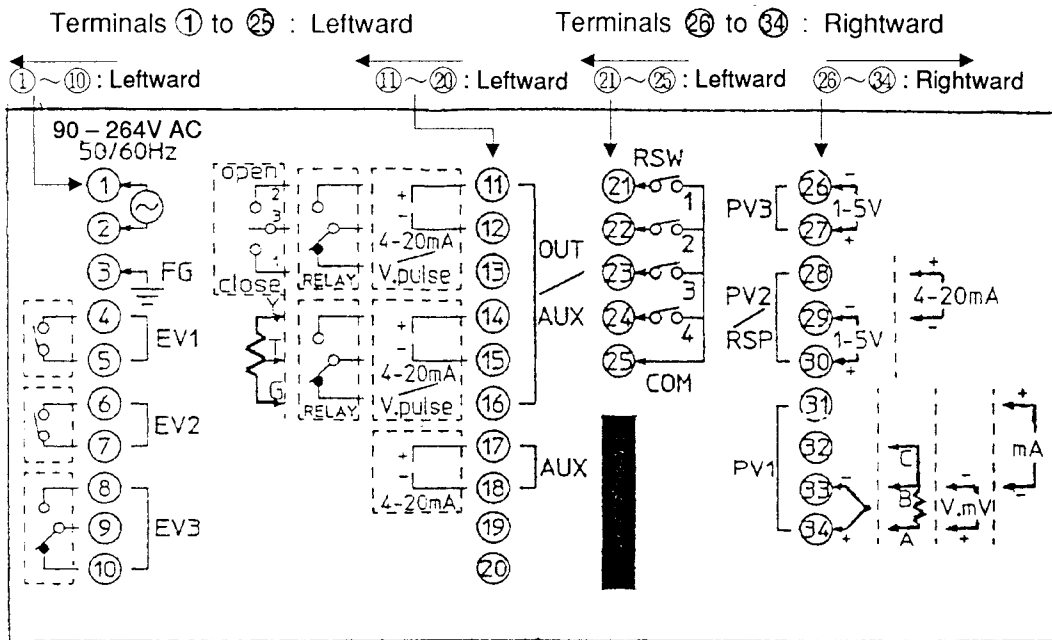

When connecting terminals ⑭, ⑮ and ⑯ to the YTG of the motor, bundle these wires separately from the other output wires

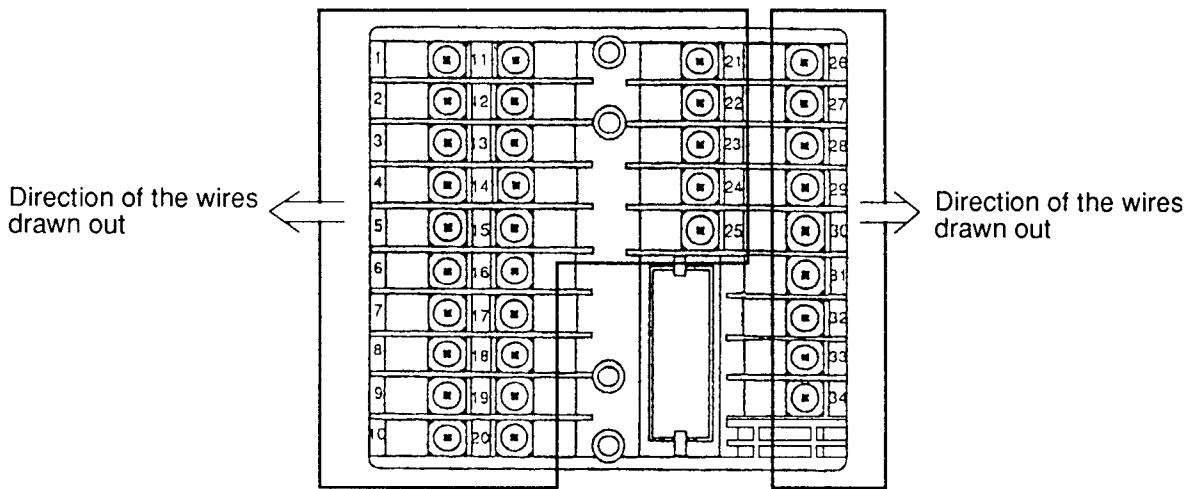

Standard terminal base layout

### 3-4 Power Supply Connections

- Obtain the SDC40A power source from a single-phase instrumentation power source not subject excess noise.
- If the power source generates noise, add an insulation transformer, and use a line filter.

Line filter Yamatake Corporation  
Model 81446364-001

Be careful not to bundle the primary and secondary coils of the power cable together. Do not put them into the same conduit or duct after introducing noise-reduction measures.

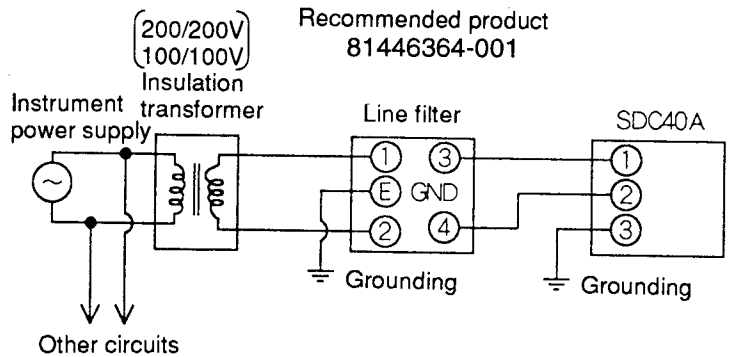
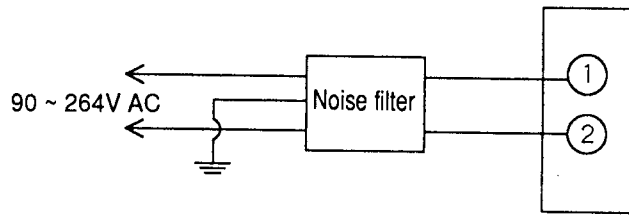

### 3-5 Grounding

Connect the instrument by one-point grounding to GND terminals (terminals ③ and FG terminal). Do not perform any jumper wiring. Mounting a grounding terminal strip separately, and connect shielded cables, etc. to the ground, if grounding work is difficult.

Grounding type :

Category 3 grounding or higher  
(Lower than 100Ω)

Grounding conductor :

Annealed copper wire more than  
2mm<sup>2</sup> (AWG14)

Grounding conductor length :

Max. 20m

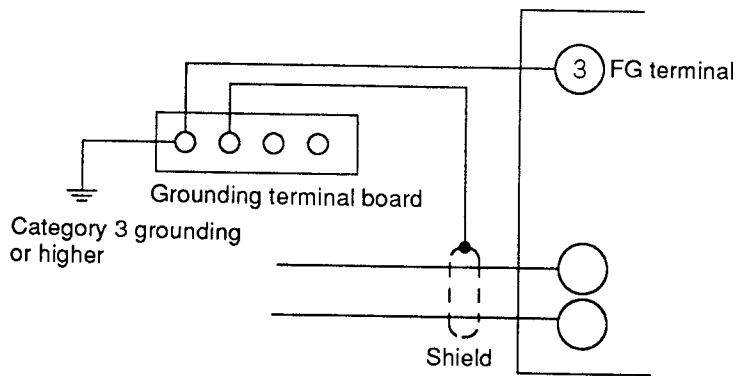

### 3-6 Terminal Connection Diagrams of Standard and Extension Terminal Bases

• Standard terminal layout

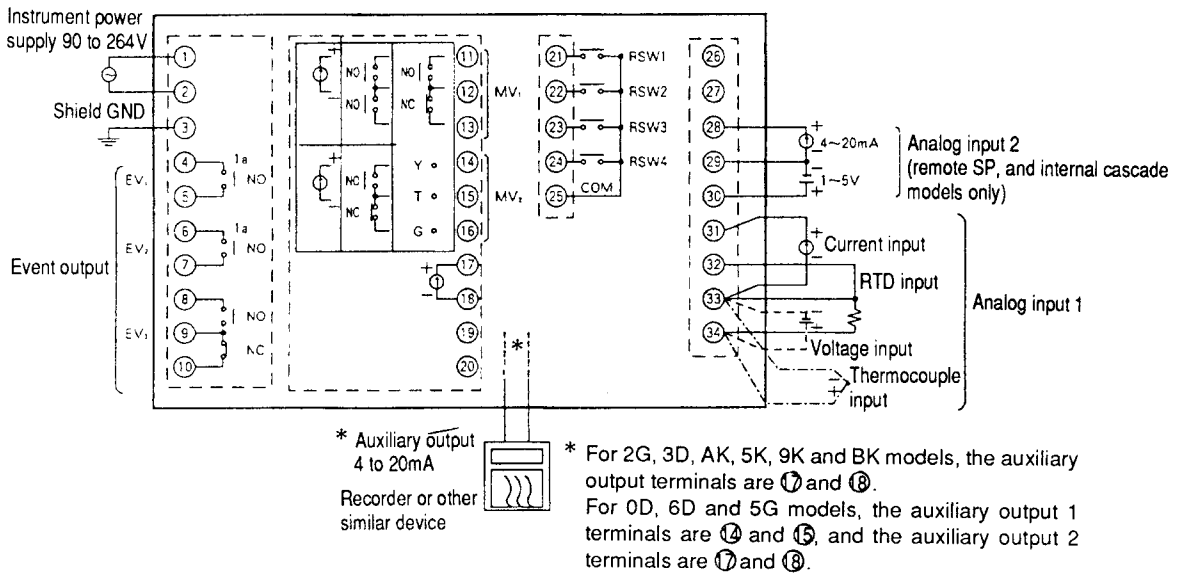

• Extension terminal layout

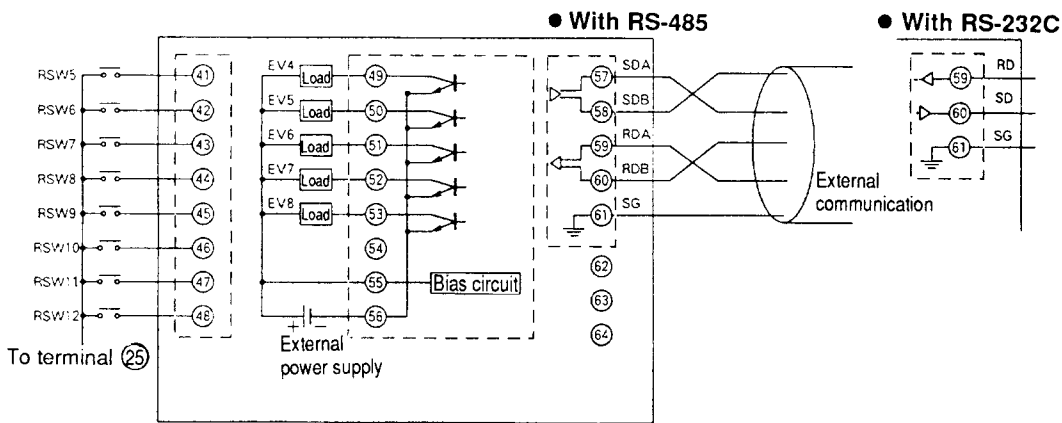

### 3-7 Input 1 (PV1) Connection

The input 1 is of a multi input type corresponding to various sensors. Connect the input 1 terminals according to each sensor as shown below.

**Note 1 :** Be careful not to apply voltage to the linear current sensor terminals (31, 33). Otherwise the instrument may malfunction.

**Note 2:** Be careful about the polarity of each sensor when making connection.

**Note 3:** Use a shielded cable for connection of each sensor.

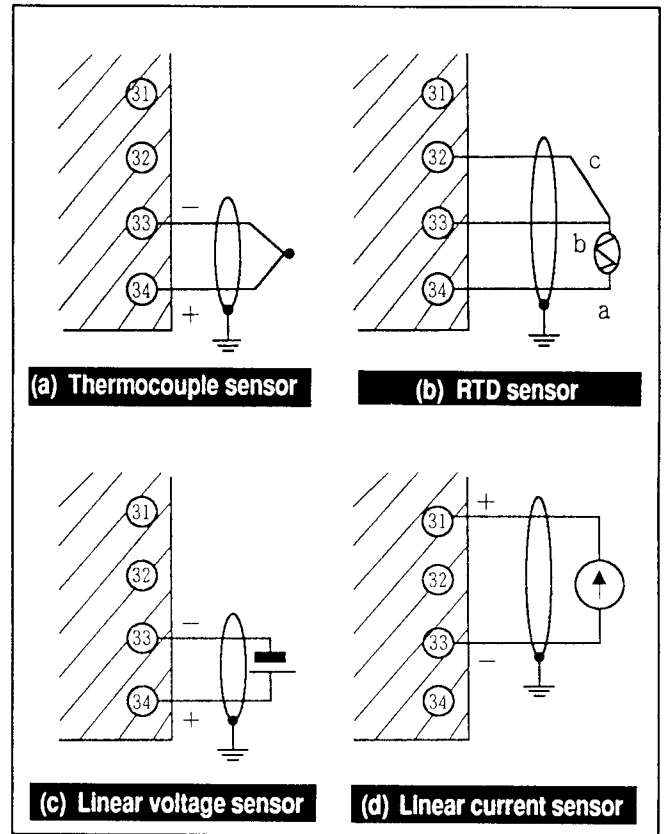

### 3-8 Input 2 (PV2/RSP) Connection (remote SP, and internal cascade models only)

Connect either instrumentation input of 1 to 5V DC or 4 to 20mA DC to the input 2 terminals as shown below.

**Note 1 :** Be careful not to apply voltage to the input terminals of 4 to 20mA DC (28, 29). Otherwise the instrument may malfunction.

**Note 2:** Be careful about the polarity of the input when making connection.

**Note 3:** Use a shielded cables for connection of the input.

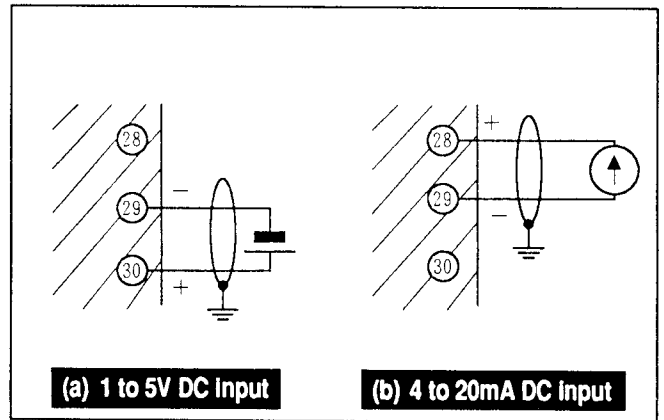

### 3-9 Control Output Connection

The control output of this instrument is determined, depending upon the model number. After sufficiently checking the model numbers of this instrument and the actuator to be used, make connections. Note that the control output of each model cannot be changed into any other type of control output.

#### 1. With single output

Connect the relay output (0D), current output (5G) or voltage output (6D) as shown below.

**Note :** When a small current/low voltage is to be switched, use a bleeder resistance to obtain the sufficient current/voltage value for the minimum switching capacity of the relay.

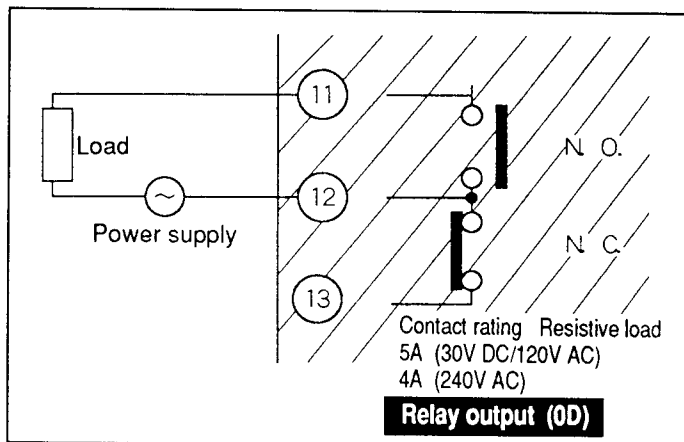

**Note :** Never connect nor disconnect the actuator with the power supply to this instrument kept closed. Otherwise, the actuator may cause a fault.

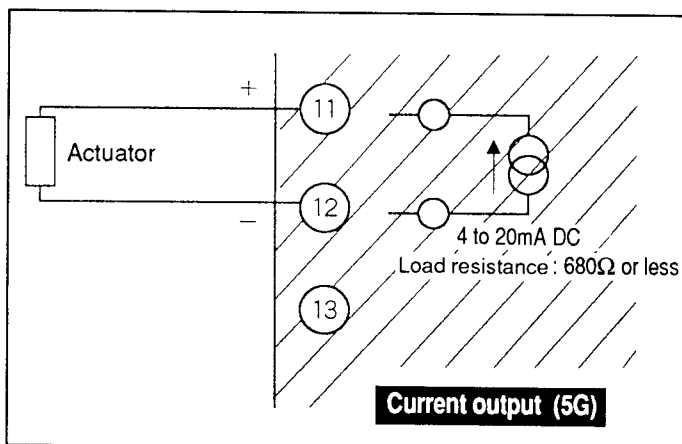

**Note :** The voltage output circuit is a constant-current circuit internally. Set the current value by setup C79 according to the conditions for the SSR and load to be used to obtain an optimum voltage. At delivery from the factory, this voltage is set to the same value as the voltage value of general SSR.

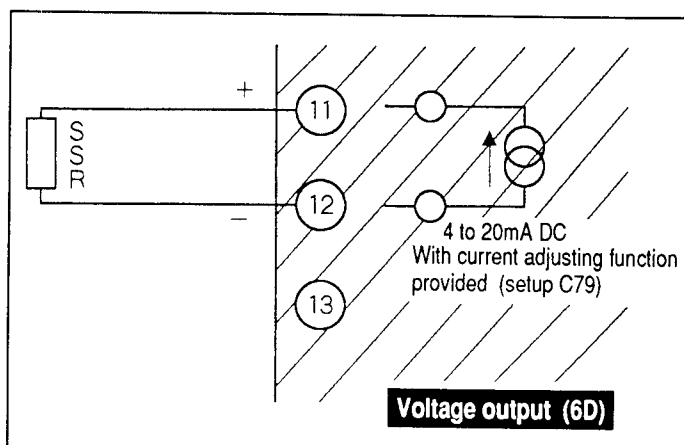

**2. With position proportional output (2G)**

Connect the feedback resistor and control output as shown below, exercising utmost care about the switching direction.

**Note 1:** The built-in relay has a limited life. Avoid setting such PID constants that ON-OFF operation of the relay is repeated excessively.

**Note 2:** When a motor for 100V/200V AC is to be used, exercise care about the inrush current as well as the contact rating, and use an auxiliary relay when necessary.

**Note 3:** Never lay the cable to the motor terminals (11), (12) and (13) and that to the feedback resistor terminals (14), (15) and (16) through the same wire duct, nor connect a 6-conductor cable to these terminals, but separate the above-mentioned two cables 30cm or more from each other. Otherwise, this instrument may cause a trouble due to the starting noise, etc. of the motor.

**Note 4:** Terminals (14), (15) and (16) may not be required (when no feedback resistor is provided).

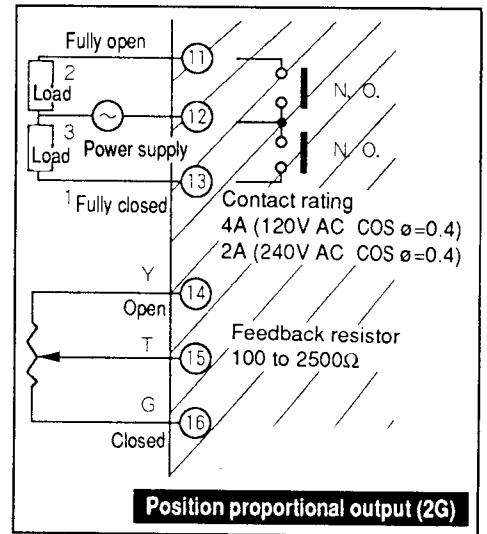

**3. With heat/cool control output (5K, AK, BK, 9K, 3D)**

The single outputs are combined. Make connection as shown below. Set the heat side and cool side by parameters in advance.

As for precautions in connection, observe the notes given in the case of the single output.

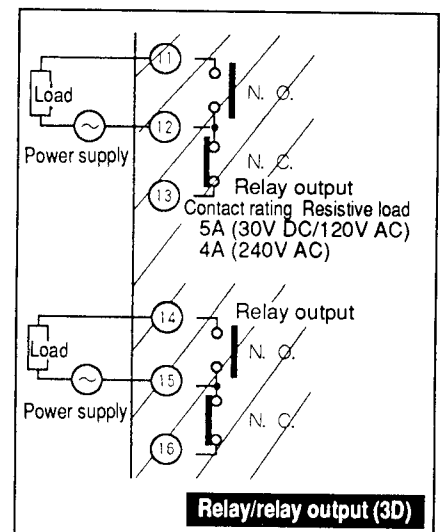
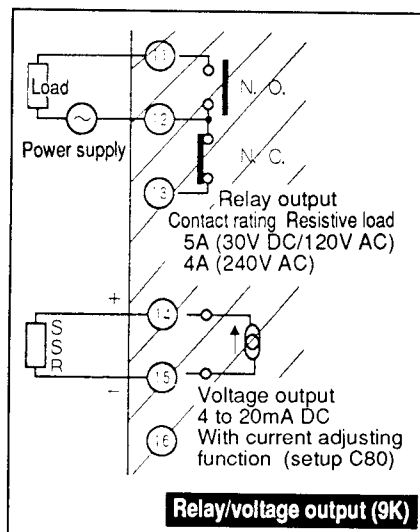
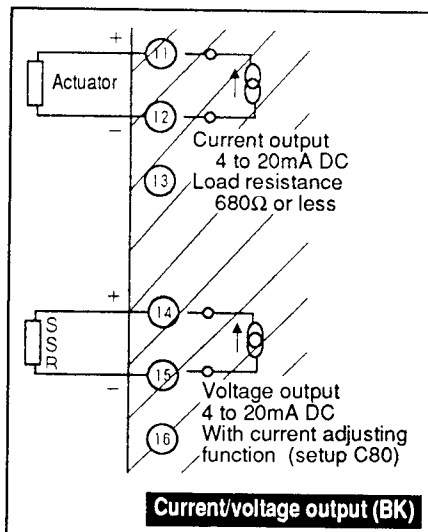
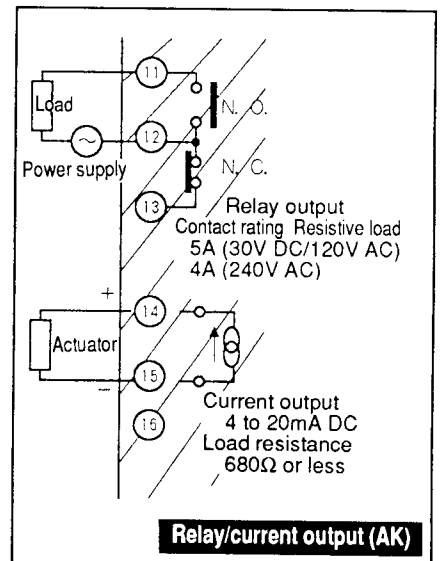
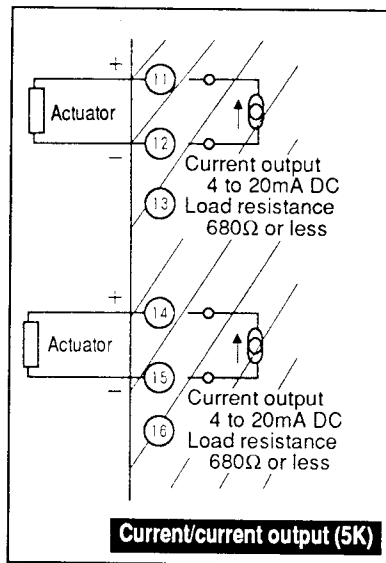

### 3-10 Connection of Auxiliary Output 1, 2 (option)

This instrument can be provided with up to one auxiliary output when the control output is position proportional (2G) output or heat/cool output, and up to two auxiliary outputs in case of any other control output.

The terminals ⑰ and ⑱ only are used for the auxiliary output in case of 2G "heat/cool control". In any other cases, the terminals ⑭ and ⑮ are used for auxiliary output 1, and the terminals ⑰ and ⑱ for auxiliary output 2.

**Note 1:** Never connect nor disconnect the receiver with the power supply to this instrument kept on. Otherwise, the receiver may cause a trouble.

**Note 2:** Use shielded cables for connection.

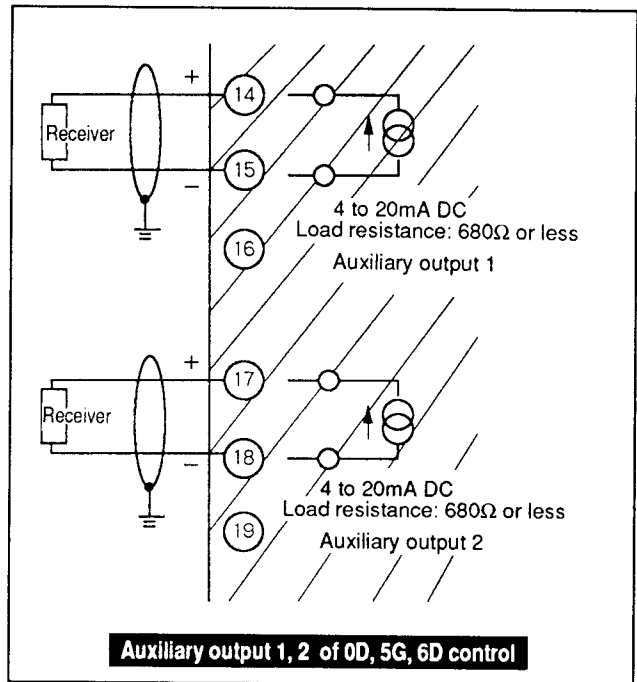
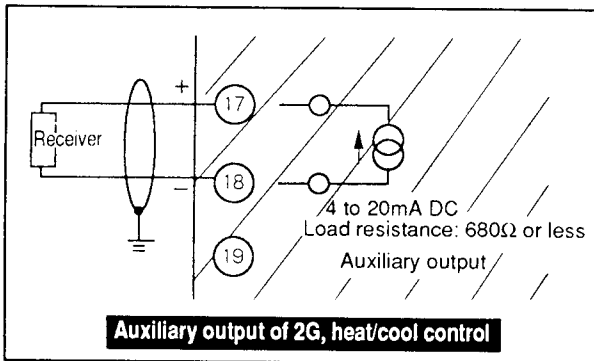

### 3-11 Connection of Relay Event Output

This instrument is provided with two points (1a contact each) of relay event output as standard, and one point (1a1b contact) of relay event output as option. Connect these relay event outputs as shown below.

**Note :** When a small current/low voltage is to be switched, use a bleeder resistance to obtain the sufficient current/voltage value for the minimum switching capacity of the relay.

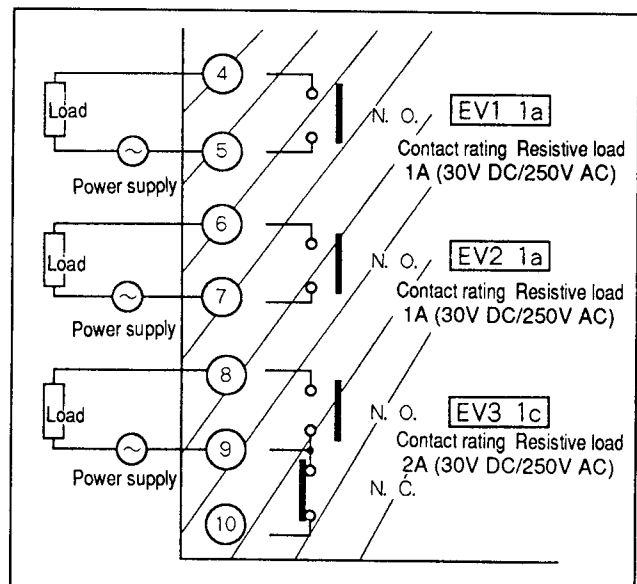

### 3-12 Connection of Open Collector Event Output (option)

Make wiring on the attached terminal base.

- Note 1:** Be sure to connect the terminal (55) to the + terminal of the external power supply. Otherwise, the event output does not operate.
- Note 2:** Never short circuit between the + terminal of the external power supply and terminals (49) to (53) of this instrument. Otherwise, the event output becomes defective. (A short circuit preventive circuit is not incorporated.)
- Note 3:** When a semiconductor load such as a program controller (sequencer) is to be connected, select such a module that the direction of current is coincident. This load must not be affected adversely by a leak current when the event output of the instrument is turned off.

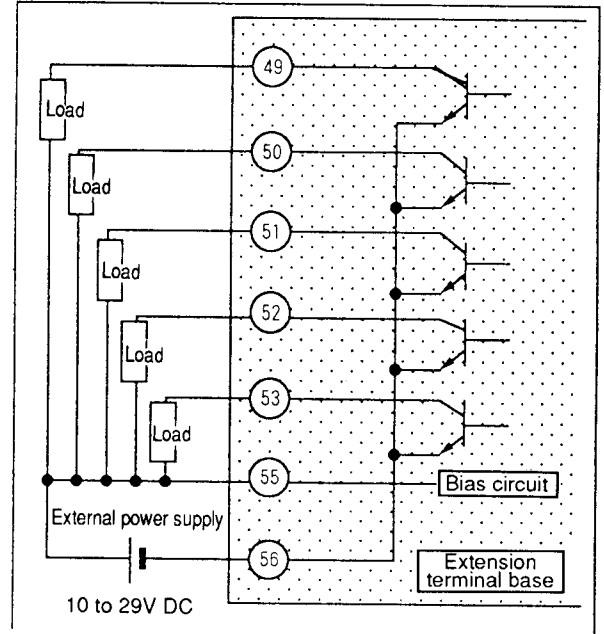

### 3-13 Connection of Remote Switch Input (option)

This instrument can be provided with 4 points or 12 points (8 points out of 12 points are mounted on the extension terminal base) of remote switch input as option. In case of 12 points of remote switch input, wiring is made on both standard terminal base and extension terminal base.

- Note 1:** The remote switch used for this instrument is of a built-in power supply (open voltage 12V DC) type. Be sure to operate the external contacts as no-voltage contacts.
- Note 2:** Use gold contacts or the like, which can turn on and off a small current, as no-voltage contacts. Other kinds of relay contacts may not be able to turn on and off a small current. Use such contacts that have sufficient margin in the minimum switching capacity with respect to the contact current and open voltage of this instrument.
- Note 3:** When semiconductors (such as open collector) are used as no-voltage contacts, the voltage across the contacts should be 3V max. when the contacts are turned on. The leak current at turn-off time should be 100 $\mu$ A max.

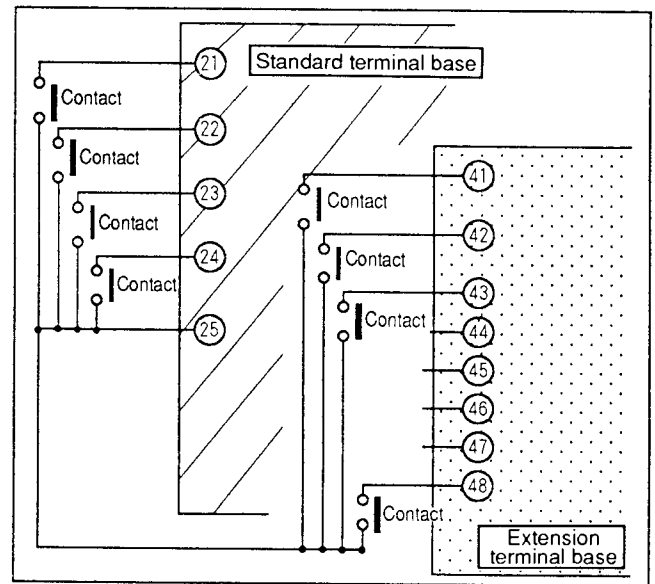

- Note 4:** A remote switch can be connected in parallel with two or more SDC40 series units. When it is to be connected in parallel with this instrument and other type of instrument, check the conditions for the other instrument sufficiently before instrumentation.

Internal circuit of portion of this instrument where remote switches are connected

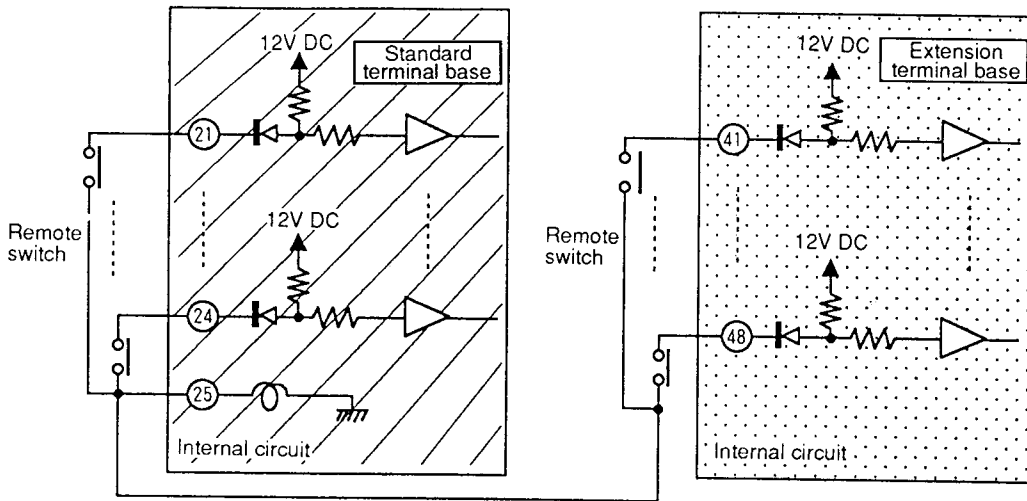

3-14 Communication (option) Connection

The communication functions of this instrument are classified into RS-232C type and RS-485 type by the model number. After checking the communication type of your instrument, make connection as shown below.

**Note 1:** This instrument always serves as a slave station. The RS-485 type permits slave stations to be multi-connected.

**Note 2:** In the RS-485 (5-wire system), connect one each terminating resistor between the RDA and RDB terminals of each of the master station and the slave station furthest from the master station. Use the terminating resistors of 150Ω and 1/2W min.

**Note 3:** When making three-wire system connection in the RS-485 type, short circuit between (57) and (59) and between (58) and (60) of this instrument.

**Note 4:** In the RS-485 (3-wire system) type, connect one each terminating resistor to both physical ends of RDA and RDB lines, or both physical ends of SDA and SDB lines. Use the terminating resistors of 150Ω and 1/2W min.

**Note 5:** Be sure to assign a unique address to each slave station.

**Note 6:** Never short circuit between RDA and RDB or SDA and SDB terminals. Otherwise, this instrument may be damaged.

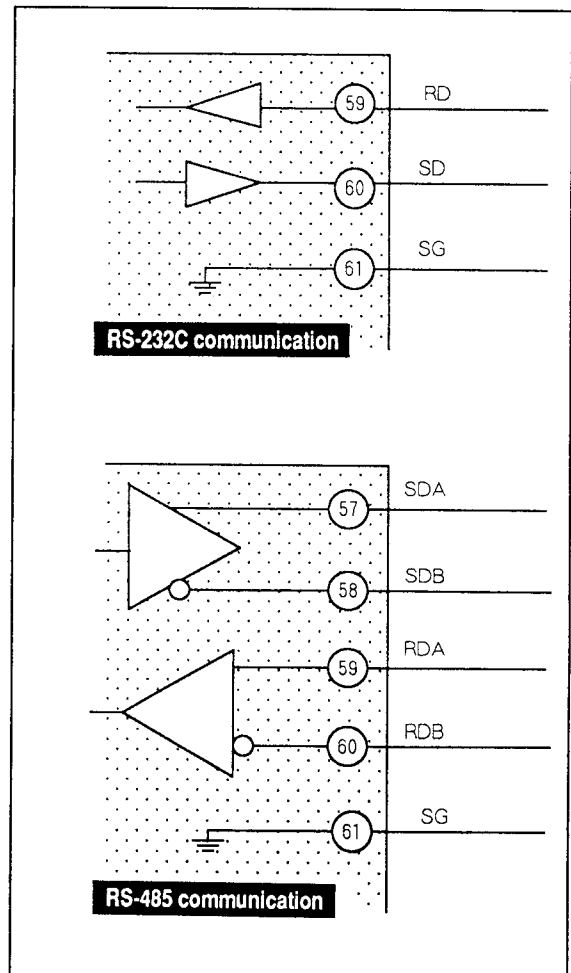

### 5-wire system RS-485 interconnection diagram

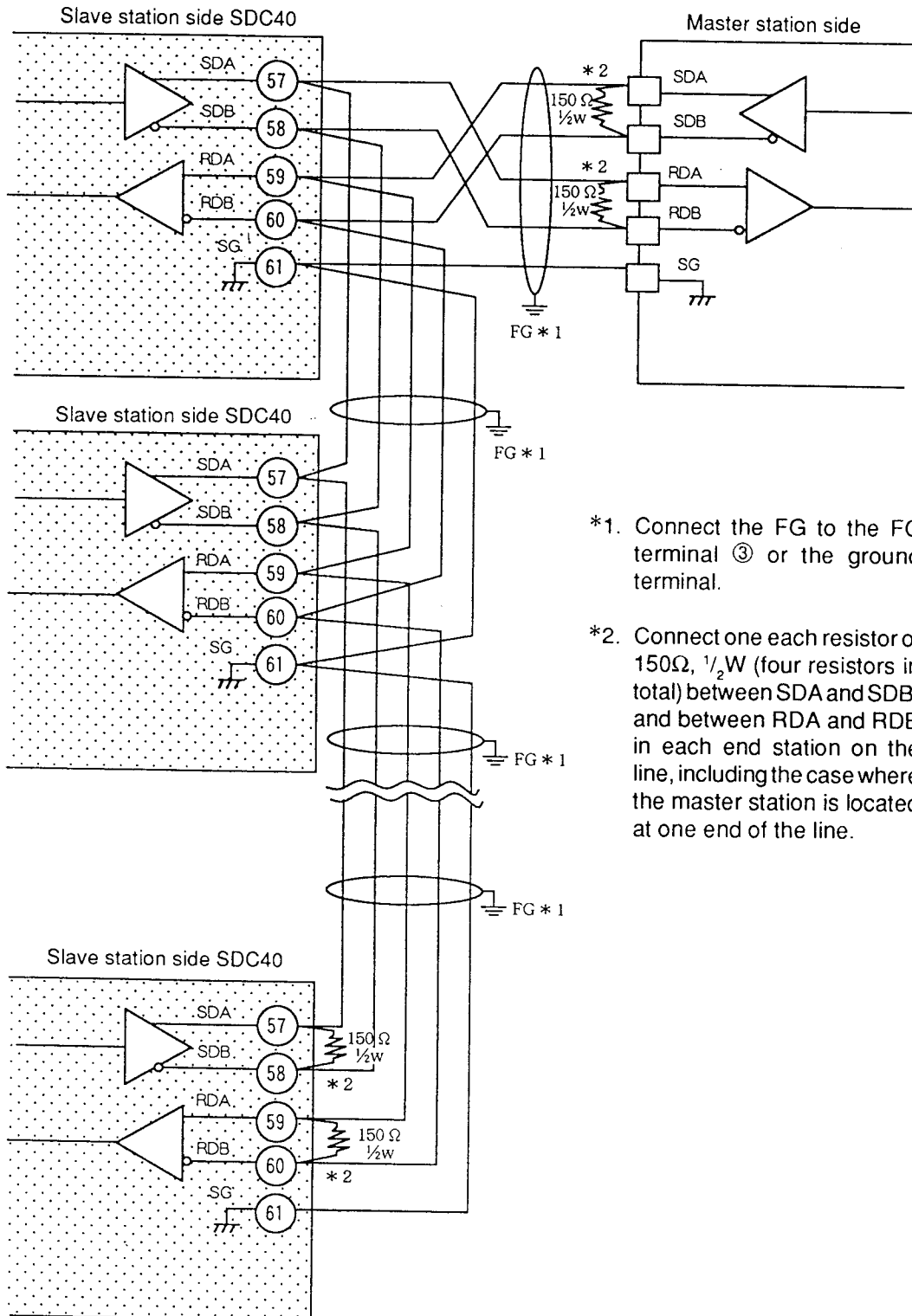

\*1. Connect the FG to the FG terminal ③ or the ground terminal.

\*2. Connect one each resistor of 150Ω, 1/2W (four resistors in total) between SDA and SDB, and between RDA and RDB in each end station on the line, including the case where the master station is located at one end of the line.

### 3-wire system RS-485 interconnection diagram

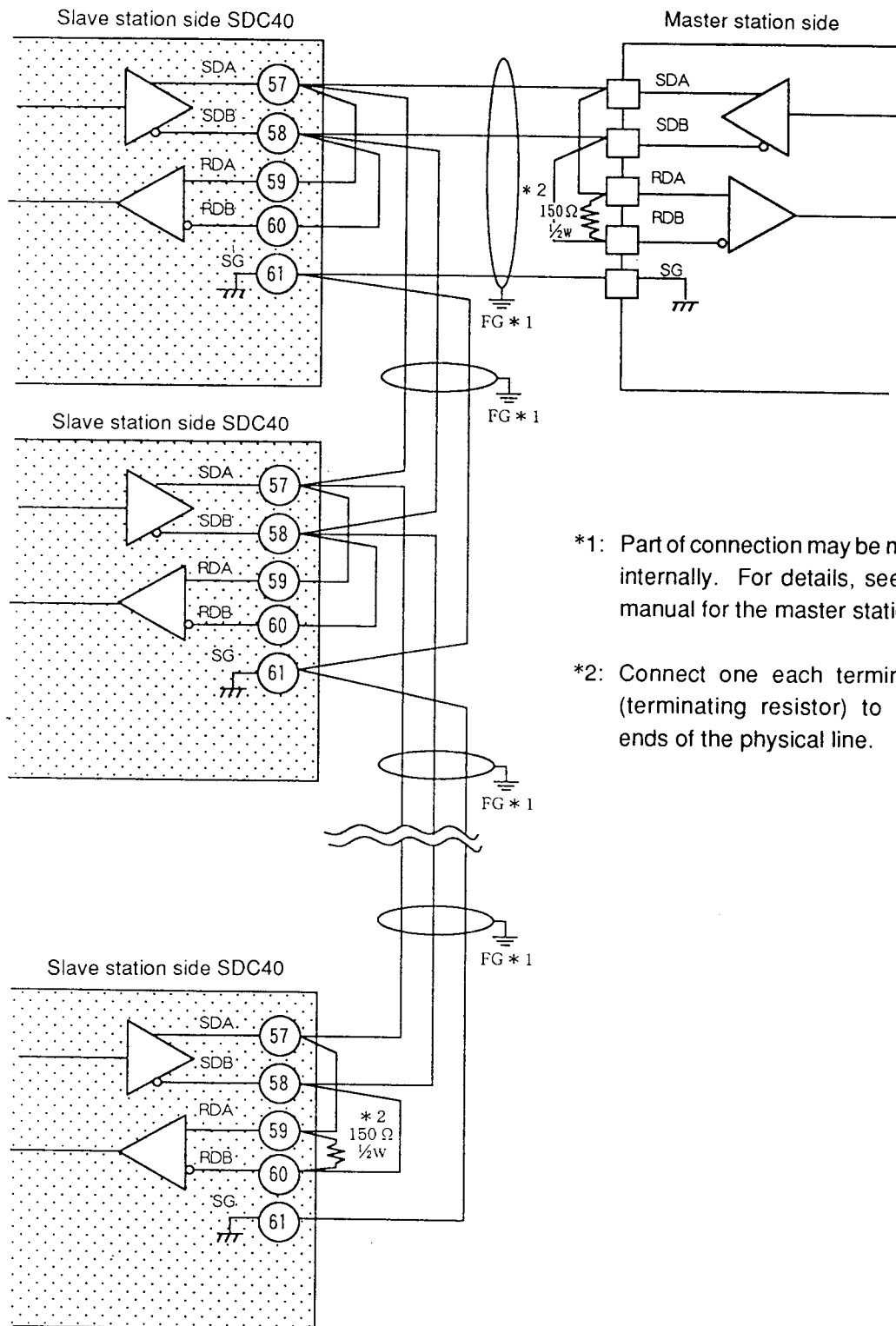

\*1: Part of connection may be made internally. For details, see the manual for the master station.

\*2: Connect one each terminator (terminating resistor) to both ends of the physical line.

### 3-15 Wiring Precautions

- Connect cables according to the instrument model number and terminal numbers on the label mounted on the side panel of this instrument. After wiring, make sure the wiring connections are correct.
- Separate input/output signal cables and communication cables more than 50cm from a drive power cable or a power cable higher than 100V. Don't pass these cables together through the same conduit or duct.
- Be careful not to allow crimped style solderless terminals to touch any adjacent terminals.
- When the thermocouple input or the like of this instrument is to be connected in parallel with other instruments, the total input impedance of the other instruments should be 1MΩ min. If the total input impedance is less than 1MΩ, a sensor disconnection may not be able to be detected.
- Cautions in combination with data input device

When the input/output (parallel connection in case of input) of the SDC40 is applied to an A/D converter or analog scanner, setc., such a trouble as dispersion in read data may occur. To prevent this trouble from occurring, take any of the following remedial measures.

[Remedial measures]

1. Use a low speed integral type A/D converter.
2. Insert an isolator having no switching power supply between the SDC40 and A/D converter.
3. Perform averaging processing by a personal computer during data reading.
4. Set an input filter to the device if possible.

### 3-16 Noise

#### 1. Noise generation sources

The following noise generation sources are the most common.

- |   |                                 |
|---|---------------------------------|
| ① Relay and contacts                              | ⑥ Phase angle control SCR       |
| ② Solenoid coils and solenoid valves              | ⑦ Radio communication equipment |
| ③ Power line (higher than 100V AC, in particular) | ⑧ Welding machine               |
| ④ Inductive load                                  | ⑨ High-voltage ignition devices |
| ⑤ Motor commutator                                |                                 |

#### 2. Measures for noise suppression

- A CR filter is effective for quick-rising noises such as impulse noise.

Recommended CR filter    Yamatake Corporation Model No. 8144636365-001

- A varistor is effective for noises with high crest values.

Be careful since the varistor is shorted if it malfunctions.

Recommended varistor    Yamatake Corporation Model No. 81446366-001 (for 100V)  
81446367-001 (for 200V)

### 3-17 Isolation between Input and Output

The following figure shows the mutual isolation between the input and output. In the following figure, the section bounded by a solid line is isolated from the rest of the circuit. The section bounded by a dotted line is not isolated from the rest of the circuit.

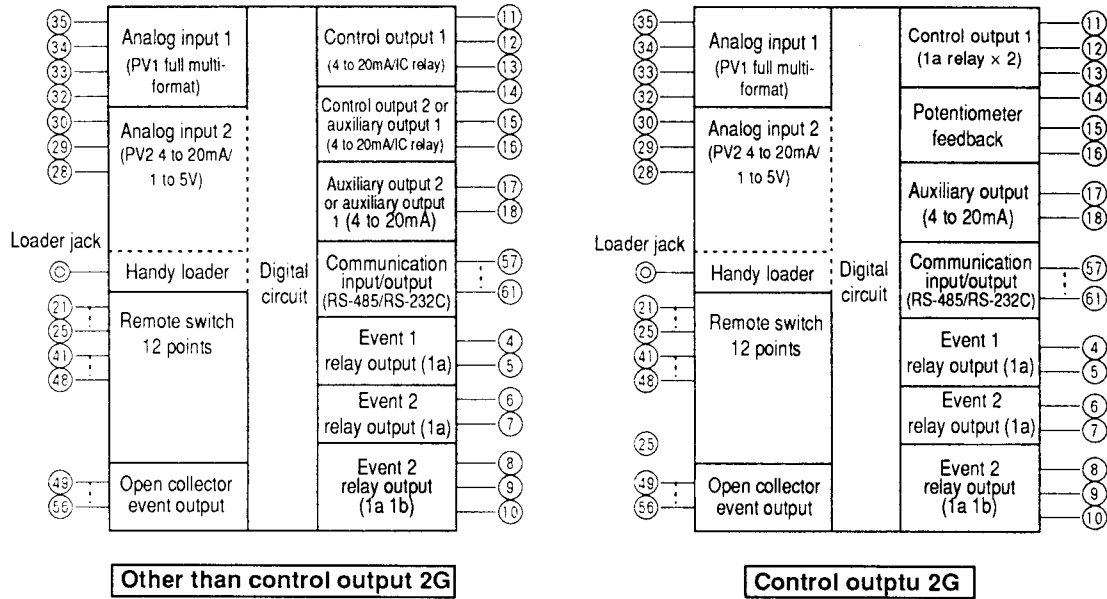

\* Since the loader jack part is not isolated from the internal digital circuit, handle it very carefully.

## Chapter 4 OUTLINE OF SETTING

### 4-1 Initialize

This instrument employs such a system that various settings and selections can be done from the keys or handy loader so as to be adaptable to various applications.

For this purpose, necessary data are required to be input as initialize. When the power supply to the instrument is turned on for the first time, first set the setup (SETUP) items by key-in operation (Chapter 7). Determine the basic features of the instrument by the setup items, then set the parameters (PARA) (Chapter 5). The setup items prepared need not be changed so frequently once they are set. When these setup items are set by key-in operation, they cannot be changed in any other than the READY mode.

### 4-2 Major Setup Items (block diagram)

The major setup items from input to output are collected in the block diagram given on the following pages. The symbols in the diagram are as shown below.

C□□ : Setup (SETUP) item number  
PARA□□ : Parameter (PARA) item number

● Standard and remote SP models

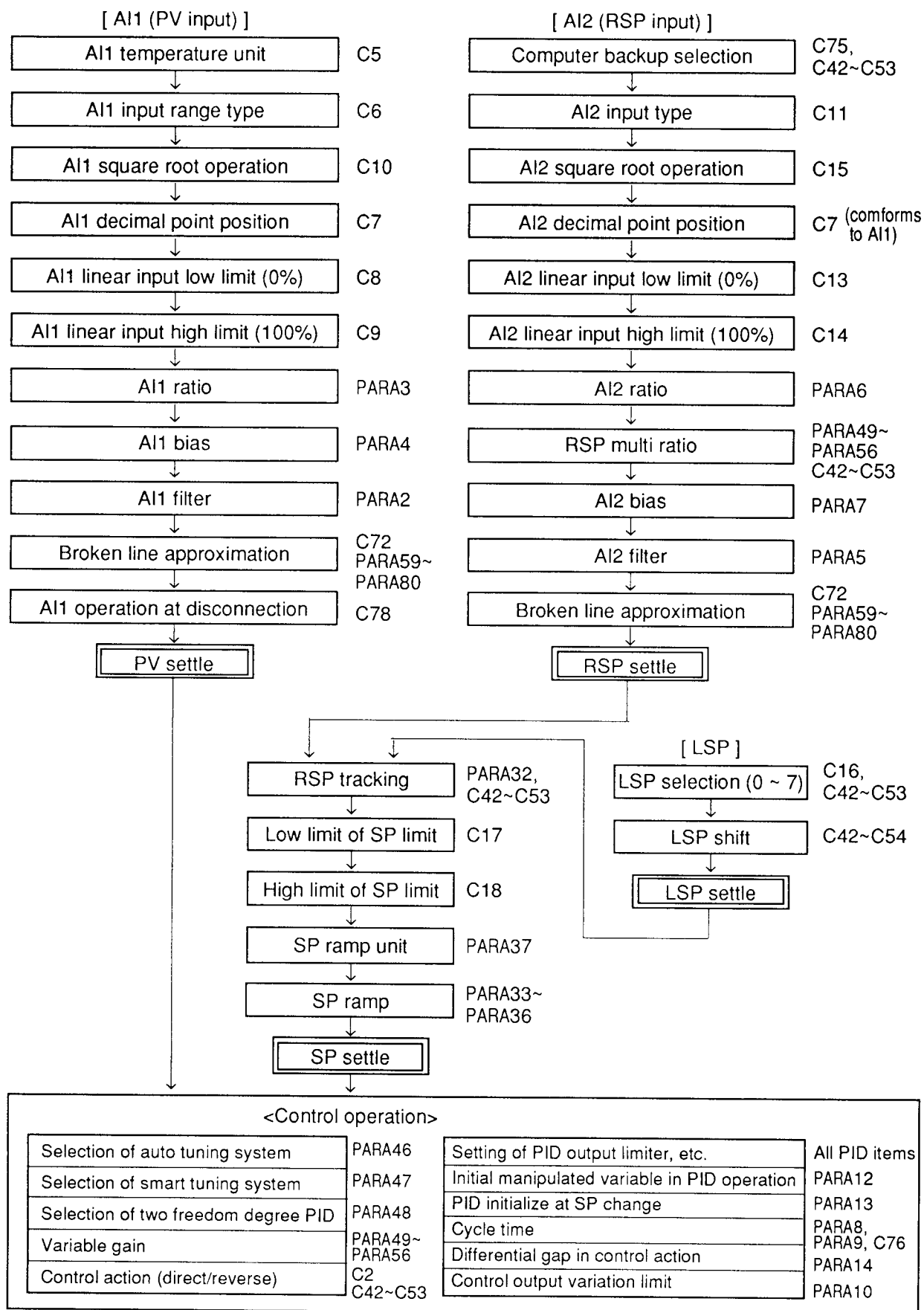

(Continued to next page)

(Continued from preceding page)

**<RUN/READY, AUTO/MAN, Fixed value output>**

Control output quantity in READY mode	C26, C27
Output at input overrange	C19, C20
Fixed value output 1 to 3	C23~C25
Manual change mode	C21
Preset manual value	C22

**<Control output adjustment>**

Motor drive adjustment	PARA40~ PARA44
Voltage output adjustment	C79, C80

Control output

**<Indication, UF keys>**

Selection of indication contents of bar graph indicator	C71
Green belt setting range	PARA38, PARA39
Indication 1 digit masking	PARA45
Indication output of LED for UF	C69, C70
Function assignment of UF1 key	C55~C59
Function assignment of UF2 key	C60~C68

**<Auxiliary output>**

Setting of auxiliary output 1	C32~C36
Setting of auxiliary output 2	C37~C41

**<Event>**

Event type, stand-by	PARA15~ PARA31
Event in READY mode	C28

● Internal cascade model

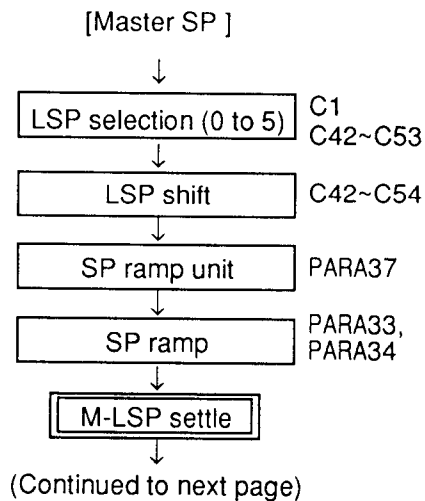
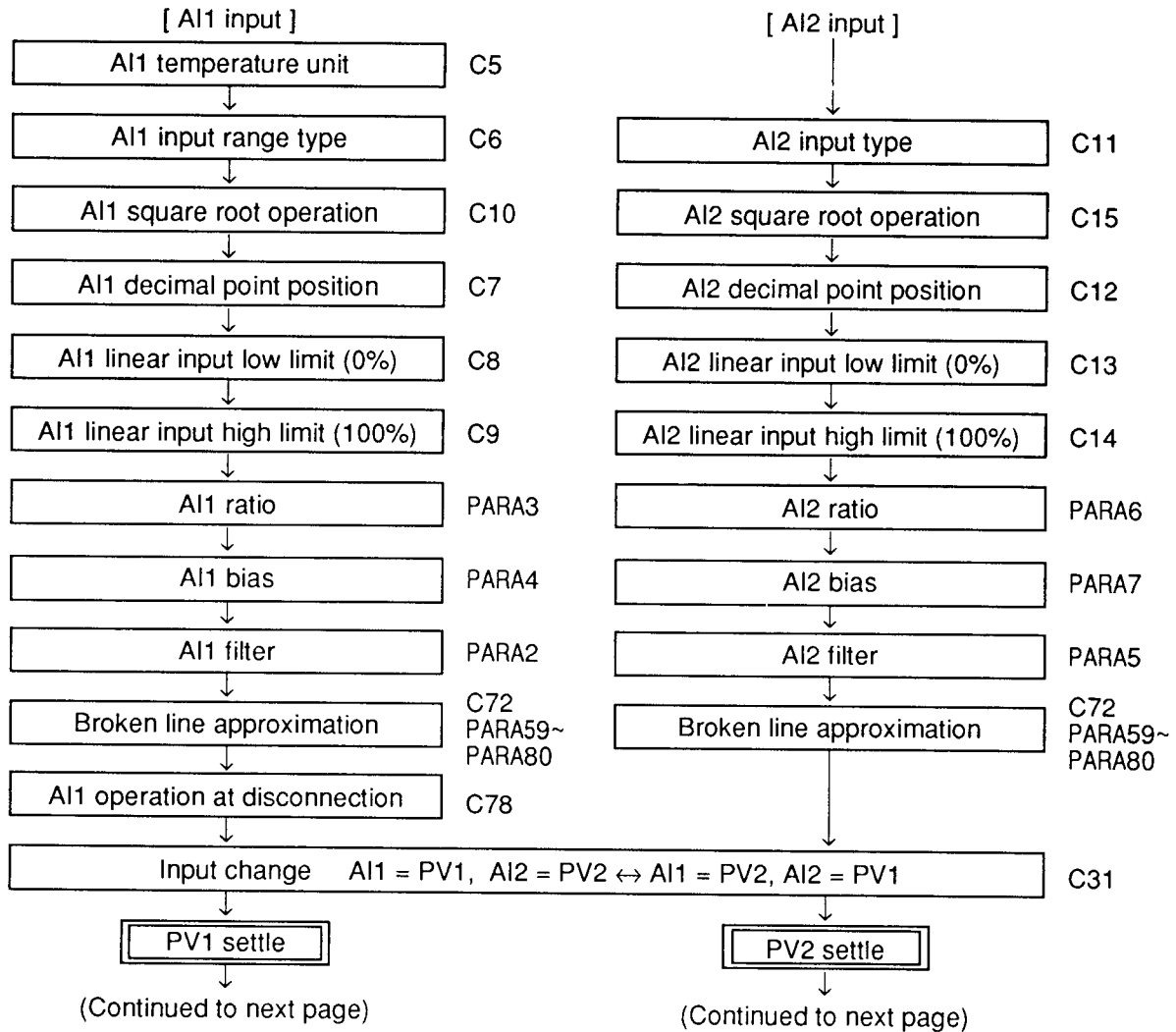

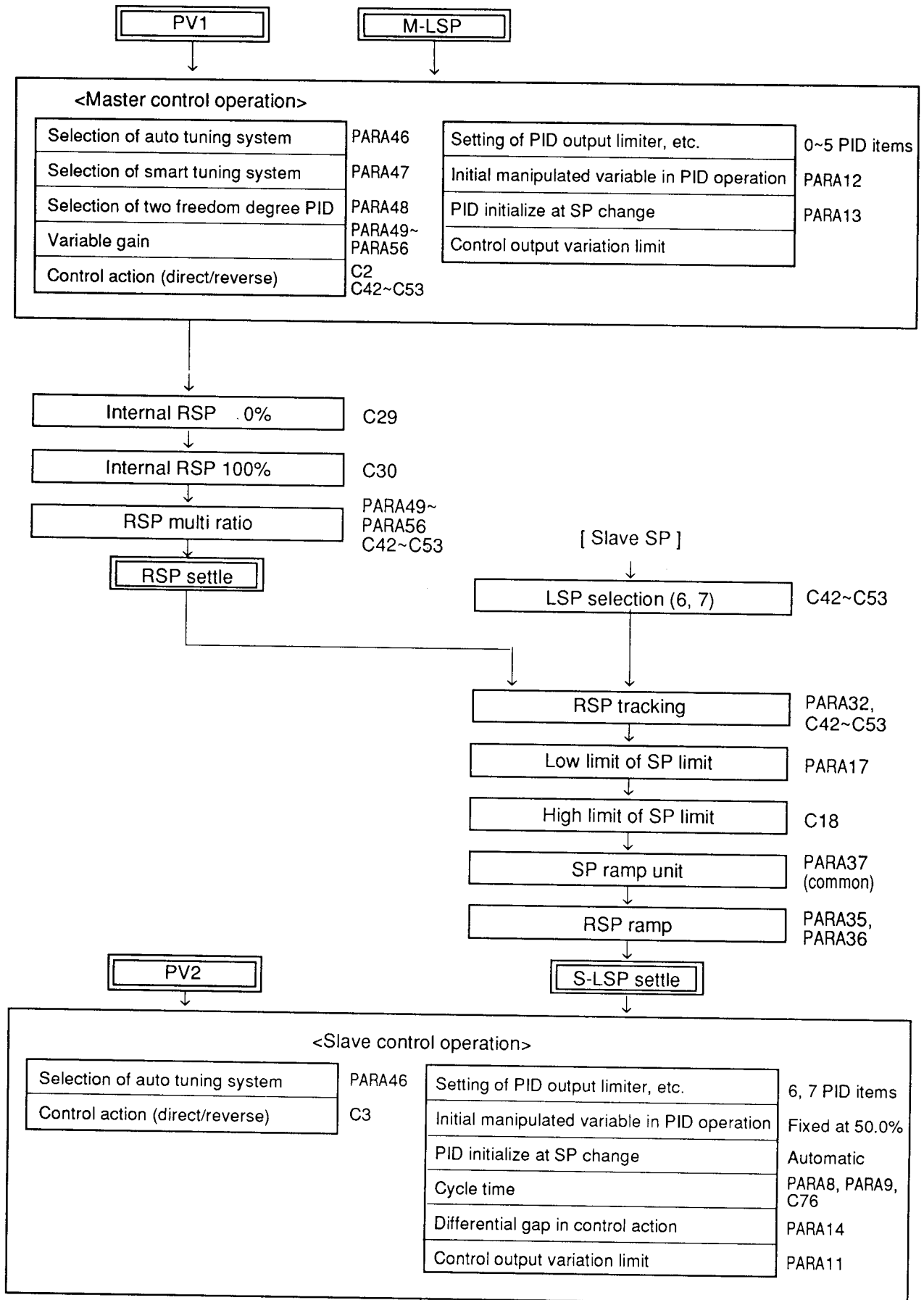

(Continued to next page)

(Continued from preceding page)

↓

<b>&lt;RUN/READY, AUTO/MAN, Fixed value output&gt;</b>	
Control output quantity in READY mode	C26, C27
Output at input overrange	C19, C20
Fixed value output 1 to 3	C23~C25
Manual change mode	C21
Preset manual value	C22

↓

<b>&lt;Control output adjustment&gt;</b>	
Motor drive adjustment	PARA40~ PARA44
Voltage output adjustment	C79, C80

↓

Control output
----------------

<b>&lt;Indication, UF keys&gt;</b>	
Selection of indication contents of bar graph indicator	C71
Green belt setting range	PARA38, PARA39
Indication 1 digit masking	PARA45
Indication output of LED for UF	C69, C70
Function assignment of UF1 key	C55~C59
Function assignment of UF2 key	C60~C68

<b>&lt;Auxiliary output&gt;</b>	
Setting of auxiliary output 1	C32~C36
Setting of auxiliary output 2	C37~C41

<b>&lt;Event&gt;</b>	
Event type, stand-by	PARA15~ PARA31
Event in READY mode	C28

# Chapter 5 SETTING OF PARAMETER (PARA) ITEMS

## 5-1 Parameter Operation

### 1. Prior to setting

Parameter items whose settings must be changed several times to improve the control functions as the results of operation of this instrument are collected for this instrument. After the system is placed in stationary operation, it is almost unnecessary to change the settings of these parameters.

There are about 50 to 80 parameter items to be set, changing depending upon the model. There are also such parameters that the same contents of setting are shared by several items or the values set at delivery from the factory can be used as they are. Therefore, to complete the proper parameter settings in short time, it is recommended to decide the parameter values in advance, using the "user's setting column", and then make actual parameter settings.

### 2. How to set and reset the parameter setting mode

Parameter setting can be done in any status (RUN/READY, AUTO/MAN, etc.) so far as the instrument is placed in the basic indication status.

In the basic indication status, a PV is indicated on the No. 1 indicator, and an SP is indicated on the No. 2 indicator. This status can be set by pressing the <sup>DISP</sup> key. Even when DEV or OUT is indicated on the No. 2 indicator in place of SP, the parameter setting mode can be set.

Three setting groups can be called sequentially by pressing the <sup>PARA</sup> key in the basic indication status. When the <sup>ENT</sup> key is pressed with **PARA** indication, the parameter item can be set. To reset the parameter setting mode, press the <sup>DISP</sup> key. The basic indication status can be reset from any status.

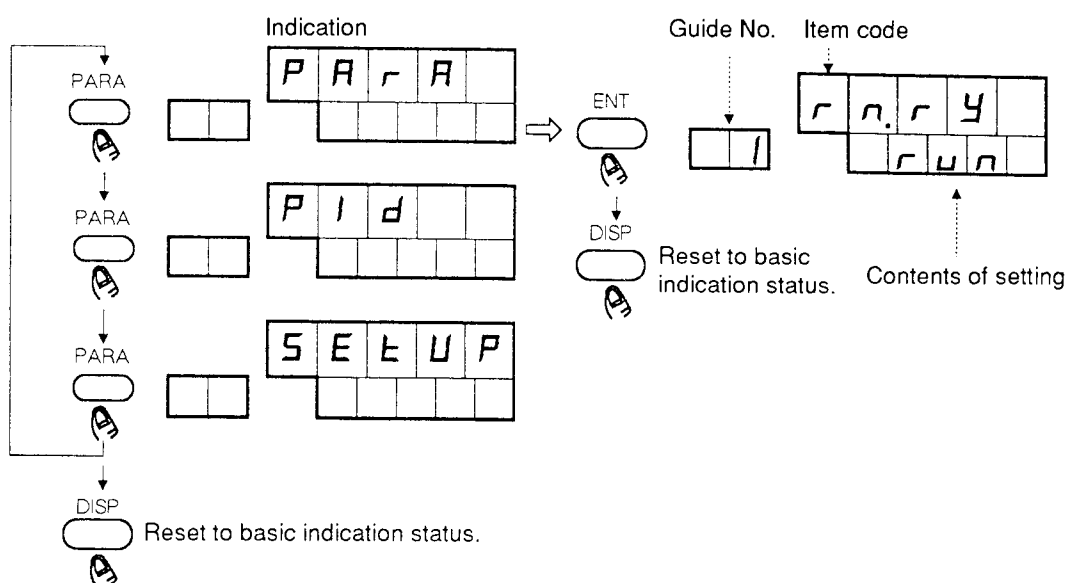



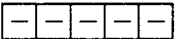

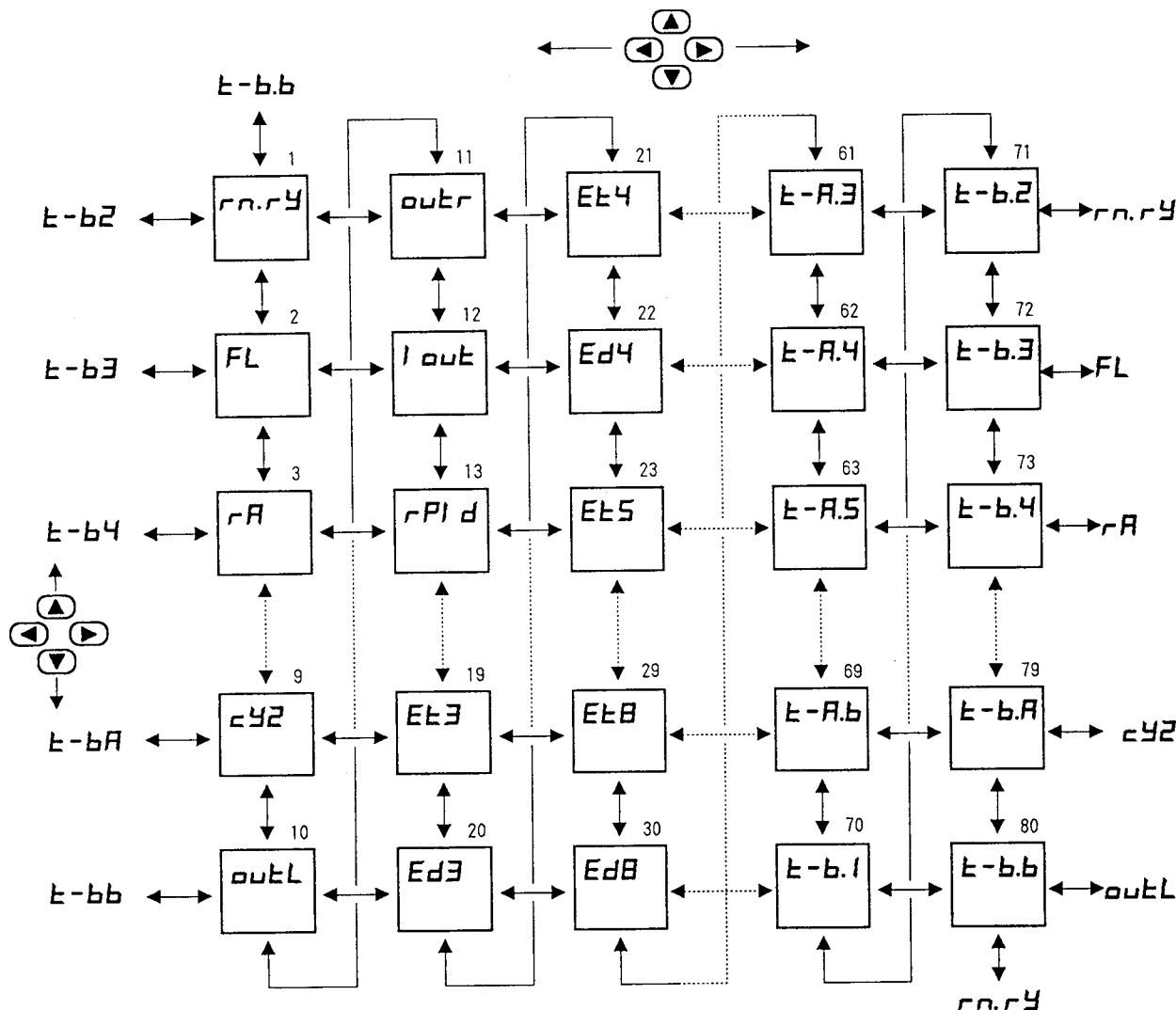
### 3. How to move the parameter items

The parameter items have a matrix construction like the two other setting groups. Each can be moved optionally by  keys as shown below.  is indicated in the No. 2 indicator for an unnecessary item, depending upon the model or the contents of setting. The figure given at the right top of a frame denoting each item means Guide No.



### 4. How to change the set value of a parameter item

To change the set value of a parameter item, press the  key when this item is indicated. The set value on the No. 2 indicator flashes, indicating that it can be readily changed. Set a desired value with  keys, and press the  key. This value is stored, and flashing stops.



If the previous value is restored when the set value flashes, don't press the  key, but press the  key to reset to the basic indication status. Then, make the same setting operation.

5-2 Parameter Item Table

Guide No.	Item code	Item	Set value at delivery from factory	User's setting column	Setting
1	<i>run.rdy</i>	RUN/READY selection	<i>rdy</i>		<p><i>run</i> : RUN <i>rdy</i> : READY</p> <p><b>Supplement</b> Setup cannot be changed in other than READY (indication only possible).</p>
2	<i>FL</i>	AI1 filter	0.0		<p>0.0 to 120.0s</p> <p><b>Supplement</b> No filter is provided at 0.0s</p>
3	<i>rR</i>	AI1 ratio	1.000		0.001 to 9.999
4	<i>bl</i>	AI1 bias	0		-1000 to 1000U
5	<i>FL2</i>	AI2 filter	0.0		<p>0.0 to 120.0s</p> <p><b>Supplement</b> No filter is provided at 0.0s AI2 functions as RSP in the remote SP model, and as PV2 in the internal cascade model.</p>
6	<i>rR2</i>	AI2 ratio	1.000		0.001 to 30.000
7	<i>bl2</i>	AI2 bias	0		-19999 to 30000U
8	<i>cy</i>	Time proportional cycle (output 1)	10		<p>5 to 120s (relay output type) 1 to 60s (voltage output type)</p>
9	<i>cy2</i>	Time proportional cycle (output 2)	10		<p>5 to 120s (relay output type) 1 to 60s (voltage output type)</p>
10	<i>outL</i>	Control output variation limit	0.0		<p>0.0 to 10.0% (updated every 0.1s) No limit is provided at 0.0.</p>
11	<i>outR</i>	Control output variation limit (MV2 of internal cascade model)	0.0		<p>0.0 to 10.0% (updated every 0.1s) No limit is provided at 0.0.</p>
12	<i>1 out</i>	PID operation initial manipulated variable at power on	0		0 to 100%

Guide No.	Item code	Item	Set value at delivery from factory	User's setting column	Setting
13	<i>r P I d</i>	PID operation initialize at SP change	0		0: Initialize decision is made automatically. 1: Initialized at each time of SP change and SP write 2: Not initialized at each time of SP change and SP write.  <div style="border: 1px solid black; padding: 2px; display: inline-block;">Supplement</div> SP change includes change into RSP.
14	<i>d I F F</i>	Differential gap at on-off control	50U		0 to 1000U Indicated in 0D, 6D output type.
		Dead zone at position proportional control	5.0		0.5 to 25.0% Indicated in 2G output type.
		Dead zone at heat/cool control	0.0		-100.0 to 50.0% Indicated in heat/cool output type.

Guide No.	Item code	Item	Set value at delivery from factory	User's setting column	Setting	
15	<i>E11</i>	Event 1 type	0		Event type 0: Direct PV 1: Reverse PV 2: Direct deviation 3: Reverse deviation 4: Direct absolute deviation value 5: Reverse absolute deviation value 6: Direct MV 7: Reverse MV 8: Direct RSP 9: Reverse RSP 10: Direct SP 11: Reverse SP 12: Direct motor feedback 13: Reverse motor feedback 14: Process alarm 15: All alarm sum 16: PV range alarm 17: Instrument alarm (except for PV range alarm) 18: Auto tuning status 19: Manual status 20: READY status 21: Local status 22: Direct PV2 23: Reverse PV2 24: Direct deviation PV2 25: Reverse deviation PV2 26: Direct absolute deviation value PV2 27: Reverse absolute deviation value PV2 28: Direct MV2 29: Reverse MV2 30: Direct SP2 31: Reverse SP2 32: Direct internal RSP 33: Reverse internal RSP 34: MFB presumed position control	
16	<i>E12</i>	Event 1 stand-by	0			
17	<i>E21</i>	Event 2 type	0			
18	<i>E22</i>	Event 2 stand-by	0			
19	<i>E31</i>	Event 3 type	0			
20	<i>E32</i>	Event 3 stand-by	0			
21	<i>E41</i>	Event 4 type	0			
22	<i>E42</i>	Event 4 stand-by	0			
23	<i>E51</i>	Event 5 type	0			
24	<i>E52</i>	Event 5 stand-by	0			
25	<i>E61</i>	Event 6 type	0			
26	<i>E62</i>	Event 6 stand-by	0			
27	<i>E71</i>	Event 7 type	0			
28	<i>E72</i>	Event 7 stand-by	0			
29	<i>E81</i>	Event 8 type	0			
30	<i>E82</i>	Event 8 stand-by	0			
31	<i>dLE</i>	Event on-delay time unit	0			0: s 1: min  <div style="border: 1px solid black; padding: 2px; display: inline-block;">Supplement</div> Common to events 1 to 3. This function is not provided for other events than 1 to 3.
32	<i>r-tr</i>	RSP tracking	0			0: Not provided. 1: Provided.

Guide No.	Item code	Item	Set value at delivery from factory	User's setting column	Setting
33	SPU	LSP up ramp	0		0 to 26000U (0: Ramp not provided)
34	SPd	LSP down ramp	0		0 to 26000U (0: Ramp not provided)
35	rSPU	RSP up ramp	0		0 to 26000U (0: Ramp not provided)
36	rSPd	RSP down ramp	0		0 to 26000U (0: Ramp not provided)
37	rR-E	SP ramp unit setting	0		0: U/min      2: U/h 1: 0.1U/min    3: 0.1U/h  <b>Supplement</b> Common to LSP and RSP.
38	gb-L	Low limit of green belt	50U		0 to 200U
39	gb-H	High limit of green belt	50U		0 to 200U
40	Π-C	Selection of motor control method	0		0: MFB control (conventional type) + Presumed position control 1: MFB control (conventional type) only 2: Presumed position control (without MFB) only
41	Π-AE	Automatic motor adjustment	0		0: Non-adjustment 1: Adjustment start  <b>Supplement</b> When "1" is selected and the  key is pressed, the motor is fully closed, then it is fully opened, and the MFB value and time are automatically measured. To stop adjustment, press the  key.
42	Π-CL	Input with motor fully closed	1000		0 to (Input with motor fully closed – 500)
43	Π-OP	Input with motor fully open	9000		(Input with motor fully closed + 500) to 10000
44	Π-E	Motor full close – full open time	30.0		5.0 to 240.0s

Guide No.	Item code	Item	Set value at delivery from factory	User's setting column	Setting
45	<i>DP</i>	Indication 1 digit masking	0		<p>0: Not provided. 1: Provided.</p> <p><b>Supplement</b> Effective for PV, SP and DEV. However, it is not effective when an SP is set.</p>
46	<i>AT</i>	Selection of auto tuning (AT) system	0		<p>0: AT is not executed. 1: General AT is executed. 2: AT preventing overshoot is executed. 3: AT by neural net is executed. 4: In the internal cascade model, the slave side auto tuning is executed in the system 1 (general AT).</p>
47	<i>ST</i>	Selection of smart tuning system (overshoot suppression control)	0		<p>0: Smart tuning is not executed. 1: Overshoot is suppressed with brake value fixed. 2: Overshoot is suppressed, while rechecking the brake value automatically.</p>
48	<i>2PI d</i>	Selection of 2 freedom degrees PID	0		<p>0: 2 freedom degrees are not used. 1: 2 freedom degrees are used.</p>

Guide No.	Item code	Item	Set value at delivery from factory	User's setting column	Setting
49	9-r	Selection of gain/RSP multi ratio	0		0: Both are not used. 1: Variable gain is used. 2: RSP multi ratio is used. (only in remote SP and internal cascade models).
50	9n-1	Gain 1 (ratio 1)	1.00 (1.000)		<p>Gain Setting range: 0.01 to 300.00 Control gain to DEV:</p> <p>Gain 1: Gain in +20% FS Gain 2: Gain in +10% FS Gain 3: Gain in +5% FS Gain 4: Gain in +2% FS Gain 5: Gain in 0% FS Gain 6: Gain in -2% FS Gain 7: Gain in -5% FS Gain 8: Gain in -10% FS Gain 9: Gain in -20% FS</p> <p>Linear approximation is applied between individual points, and both ends are extended.</p> <p>Ratio Setting range: 0.001 to 30.000 Each ratio can be selected only by a remote switch.</p>
51	9n-2	Gain 2 (ratio 2)	1.00 (1.000)		
52	9n-3	Gain 3 (ratio 3)	1.00 (1.000)		
53	9n-4	Gain 4 (ratio 4)	1.00 (1.000)		
54	9n-5	Gain 5 (ratio 5)	1.00 (1.000)		
55	9n-6	Gain 6 (ratio 6)	1.00 (1.000)		
56	9n-7	Gain 7 (ratio 7)	1.00 (1.000)		
57	9n-8	Gain 8	1.00		
58	9n-9	Gain 9	1.00		

Guide No.	Item code	Item	Set value at delivery from factory	User's setting column	Setting
59	<i>t-A.1</i>	Input broken line approximation A1	0		<p>An: -19999 to 26000U Bn: -19999 to 26000U</p> <p><b>Supplement</b> An denotes the input axis, and Bn the output axis. For example, B1 is output with respect to A1 input. Linear correction is applied between individual points, and both ends are fixed at (-20000U, -20000U) and (26000U, 26000U).</p> <p>It is selected by C72 whether this parameter is used for A11 or A12.</p> <p>The input broken line approximation is applicable to all input types (T/C, RTD, mV, V and mA).</p>
60	<i>t-A.2</i>	Input broken line approximation A2	1000		
61	<i>t-A.3</i>	Input broken line approximation A3	1000		
62	<i>t-A.4</i>	Input broken line approximation A4	1000		
63	<i>t-A.5</i>	Input broken line approximation A5	1000		
64	<i>t-A.6</i>	Input broken line approximation A6	1000		
65	<i>t-A.7</i>	Input broken line approximation A7	1000		
66	<i>t-A.8</i>	Input broken line approximation A8	1000		
67	<i>t-A.9</i>	Input broken line approximation A9	1000		
68	<i>t-A.A</i>	Input broken line approximation A10	1000		
69	<i>t-A.b</i>	Input broken line approximation A11	1000		
70	<i>t-b.1</i>	Input broken line approximation B1	0		
71	<i>t-b.2</i>	Input broken line approximation B2	1000		
72	<i>t-b.3</i>	Input broken line approximation B3	1000		
73	<i>t-b.4</i>	Input broken line approximation B4	1000		
74	<i>t-b.5</i>	Input broken line approximation B5	1000		
75	<i>t-b.6</i>	Input broken line approximation B6	1000		
76	<i>t-b.7</i>	Input broken line approximation B7	1000		
77	<i>t-b.8</i>	Input broken line approximation B8	1000		
78	<i>t-b.9</i>	Input broken line approximation B9	1000		
79	<i>t-b.A</i>	Input broken line approximation B10	1000		
80	<i>t-b.b</i>	Input broken line approximation B11	1000		

### 5-3 Detailed Description of Parameter Items

(Figure in brackets [ ] denotes a set value at delivery from the factory.)

1: *rn.rY* RUN/READY selection [ *rdY* ]

RUN means the usual control status. In READY, control operation is stopped, and the quantity set by C28, 27 is output as a control output. It can be selected by C28 whether an event is operated or not even in the READY mode. Setup items cannot be changed in any other status than READY, except for key lock selection C1. However, when setup items have been registered in the UF keys, they can also be changed even in the READY status.

2: *FL* AI1 filter [0.0]

0.0 to 120.0s (no filter is provided at 0.0)

A primary delay digital filter can be applied to AI1 (analog input 1).

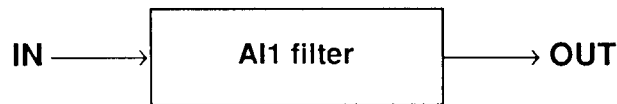

$$OUT = OUT_{-1} + (IN - OUT_{-1}) / (T/Ts + 1)$$

IN : Input to AI1 filter

OUT : Current filter operation output

OUT<sub>-1</sub> : Previous filter operation output

T : Filter set value (s)

Ts : Sampling cycle (0.1s)

3: *rR* AI1 ratio [1.000]

0.001 to 9.999

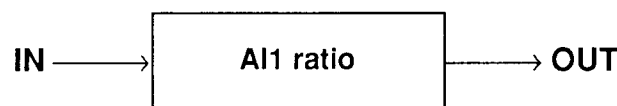

$$OUT = IN \times \text{Ratio set value}$$

4: *bI* AI1 bias [0]

-1000 to 1000U



$$OUT = IN \times \text{Bias set value}$$

Bias operation is executed after ratio operation is made.



10: *outL* Control output variation limit [0.0]  
 0.0 to 10.0% (updated every 0.1s. No limit is provided at 0.0)

This variation limit is applied after PID operation in the standard model or remote SP model, or after PID operation of the master controller in the internal cascade model. When the mode is switched from RUN to READY, or from AUTO to Preset Manual, or the control output is transferred to the fixed MV value 1, 2, 3, this variation limit functions so that the limit set value is used in each direction of increase and decrease instead of the output (%) variation after operation, if the latter is greater than the former. The example shown below shows how the actual manipulated variable changes when the manipulated variable is changed from 20% to 22% with the variation limit set to 0.5%. The output is increased by 0.5% every 0.1s and it reaches 22% after 0.4s.

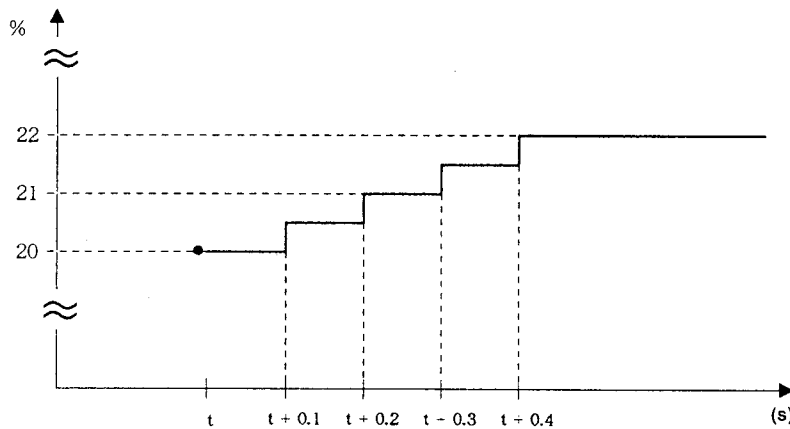

11: *outr* Control output variation limit [0.0]  
 0.0 to 10.0% (updated every 0.1s No limits is provided at 0.0)

This variation limit is applied after PID operation of the slave side controller is made in the internal cascade model. The applying manner is the same as in [ *outL* ].

12: *lout* Initial manipulated variable in PID operation at power on [ 0 ]  
 0 to 100%

PID operation starts with this initial manipulated variable when the PID operation in the standard model or remote SP model, or the PID operation of the master controller in the internal cascade model meets the following condition.

- When the power supply is turned on in the AUTO and RUN modes.
- When the READY mode is switched to the RUN mode in the AUTO mode.

The initial manipulated variable of PID operation of the slave controller is fixed (50.0%) in the internal cascade model.

13: *rPid* PID operation initialize at SP change [ 0 ]  
 0: Initialize decision is executed automatically.  
 1: Initialized at each time of SP change and SP write.  
 2: Not initialized at each time of SP change and SP write.  
 (SP change includes LSP ↔ RSP.)

In particular, this selection is done to prevent the PID operation output from being increased excessively by derivative action when an SP is changed. When this parameter is set to [0], decision is automatically executed mainly according to the magnitude of the absolute value deviation between a new SP and PV. When this deviation is small to a certain extent, initialize is not executed.

As for [PID operation initialize], the case of mode transfer is included in addition to the above-mentioned [ *Output* ] and [ *rPid* ]. Namely optimum initialize processing is executed internally when:

- MANUAL is changed over to AUTO in the RUN mode.
- The PID group number is changed from the console during selection in the RUN mode.

(When PID group number is not changed by a remote switch, initialize is not executed. When each set value of P, I and D is changed, initialize is not executed.)

14: *diff* Differential (The contents changes, depending up the type, as shown below.)

① Differential gap at on-off control	[50U]	<span style="border: 1px solid black; padding: 2px;">0D, 6D type</span>
0 to 1000U		
② Dead zone at position proportional control	[5.0]	<span style="border: 1px solid black; padding: 2px;">2G type</span>
0.5 to 25.0%		
③ Dead zone at heat/cool control	[0.0]	<span style="border: 1px solid black; padding: 2px;">Heat/cool</span>
-100.0% to 50.0%		

① Differential gap at on-off control

In the 0D and 6D types, on-off control is executed when P = 0, and the differential gap at that time is set.

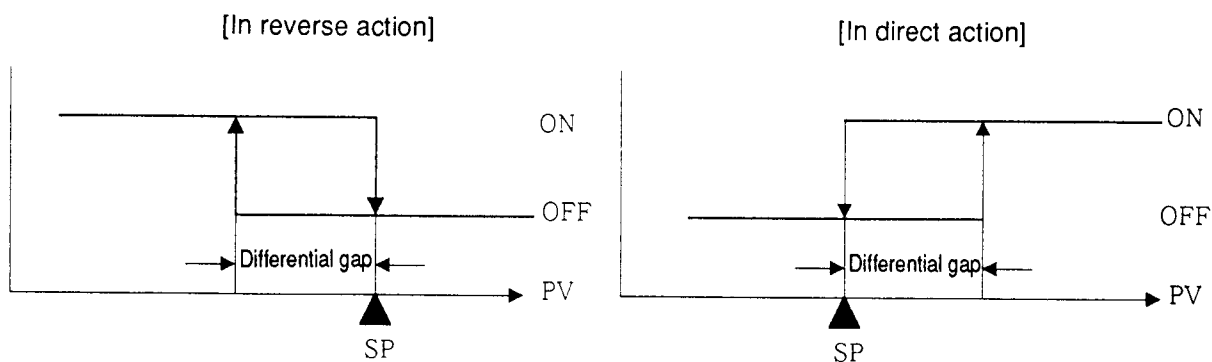

② Dead zone at position proportional control

In the 2G type, the dead zone between motor open and motor close is set. As setting reference, send the constant manual output, and change the dead zone until motor hunting stops. This is a minimum value of the dead zone. However, setting of a critical value may cause the life of the motor to be shortened extremely since the motor is always operated. Set this parameter value with the 5% at delivery used as reference, considering the control result and motor life.

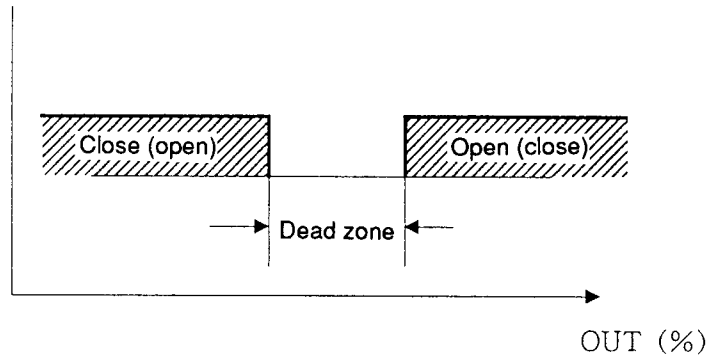

③ Dead zone at heat/cool control

In the heat/cool type, set the dead zone from the relation between the heat side output and cool side output with respect to the result of PID operation.

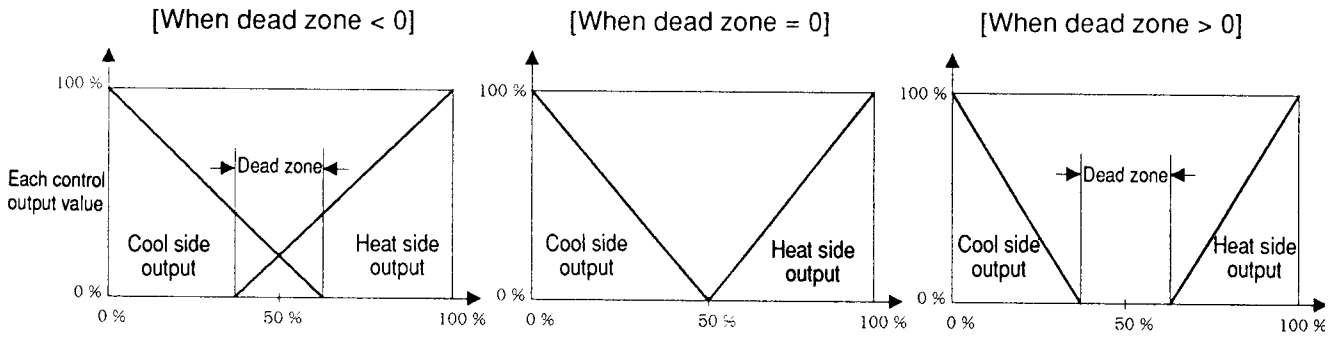

**Results of internal PID operation**

15:	<i>EEI</i>	Event 1 type
16:	<i>EdI</i>	Event 1 stand-by
	┌   ┌	┌
29:	<i>EEB</i>	Event 8 type
30:	<i>EdB</i>	Event 8 stand-by

These parameters are used to select each event type, and designate whether or not it is provided with a stand-by sequence. The set value and differential gap of an event, and the event on delay time of event 1 to 3 are set by EV setting (page 9-10). When the number of events is determined by the model number, more events cannot be set.

For the event types and assignment numbers, see the next page.

As for the events (direct deviation, reverse deviation, absolute value deviation, direct SP, and reverse SP) related with an SP or RSP, event occurrence processing is executed on the base of the value of varying SP (RSP).

As for the motor feedback (MFB) event, event occurrence processing is executed, using the presumed value of position presumption under execution.

Note that this event may occur at a position other than the actual angle of the motor.

A process alarm (process diagnosis event) is an event to detect the case where a PV does not move in the control direction of the controller. This cannot be activated in other than the event 1 to 3. Definitely, a process alarm is produced when the following three conditions are satisfied.

- 1) A manipulated variable exceeding the set output value (0 to 100%) of the event is output.
- 2) A PV does not rise (fall in direct action) beyond the differential gap of the event.
- 3) The above-mentioned status continues for longer than the on delay time of the event.

For the stand-by, either 0: stand-by not provided or 1: stand-by provided is selected. When the stand-by provided, it is reset if the event is turned off after the power supply is turned on or the READY mode is changed over to the RUN mode. Thus, the same action as the stand-by is not provided is performed subsequently.

31:	<i>dLE</i>	Event on delay time unit	[ 0 ]
		0: s	
		1: min	

The event on delay time unit is set in common to the events 1 to 3. This function is not provided for the events 4 to 8. This parameter cannot be set when the contents of assignment are 14 to 21 and 34.

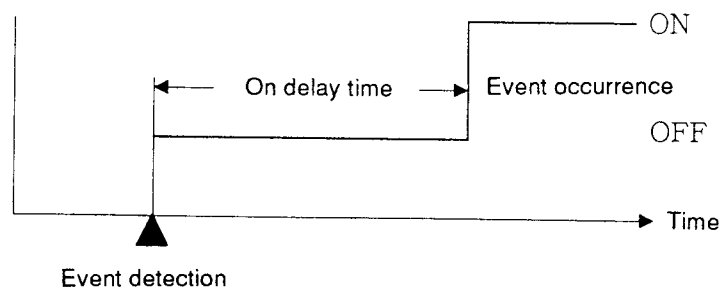

[Contents of event type assignment]

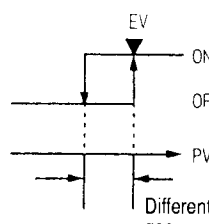
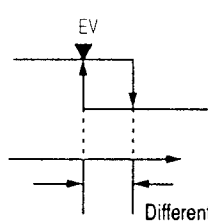
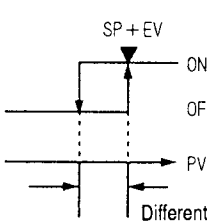
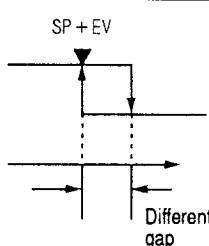
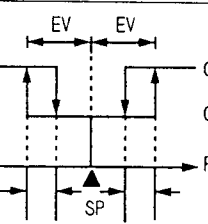
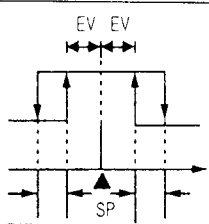
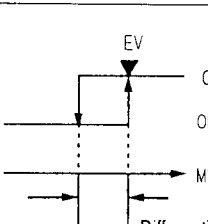
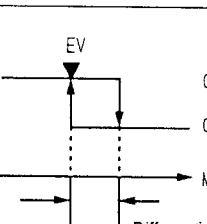
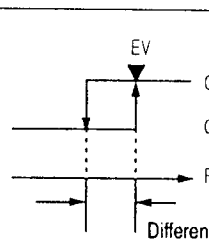
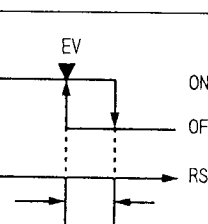
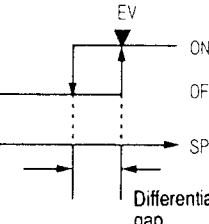
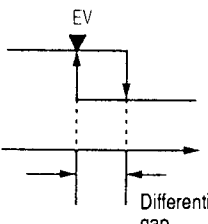
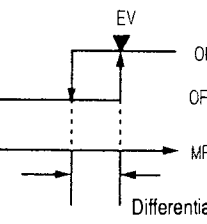
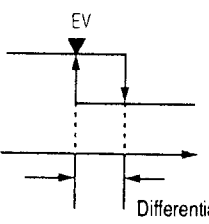
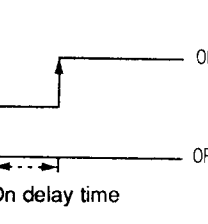
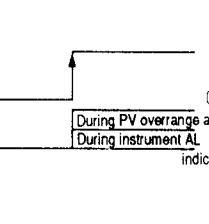
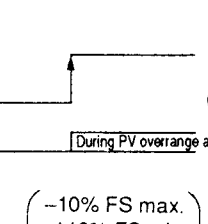
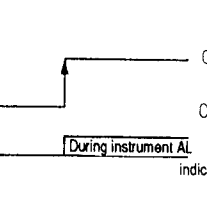
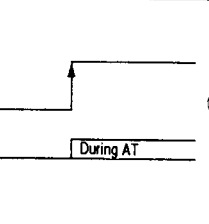
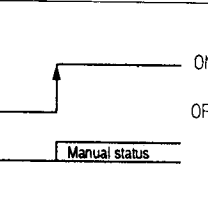
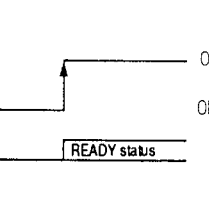
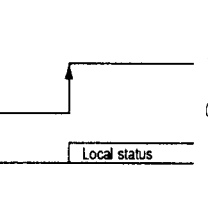
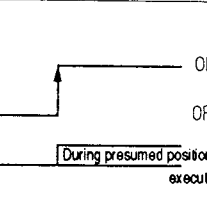
<p>0: Direct PV 22: Direct PV2</p> 	<p>1: Reverse PV 23: Reverse PV2</p> 	<p>2: Direct deviation 24: Direct deviation PV2</p> 	<p>3: Reverse deviation 25: Reverse deviation PV2</p> 	<p>4: Direct absolute deviation value 26: Direct absolute deviation value PV2</p> 
<p>5: Reverse absolute deviation value 27: Reverse absolute deviation value PV2</p> 	<p>6: Direct MV 28: Direct MV2</p> 	<p>7: Reverse MV 29: Reverse MV2</p> 	<p>8: Direct RSP 32: Direct internal RSP</p> 	<p>9: Reverse RSP 33: Reverse internal RSP</p> 
<p>10: Direct SP 30: Direct SP2</p> 	<p>11: Reverse SP 31: Reverse SP2</p> 	<p>12: Direct motor feedback (MFB)</p> 	<p>13: Reverse motor feedback (MFB)</p> 	<p>*1 14: Process alarm</p>  <p>On delay time</p>
<p>15: All alarm sum</p> 	<p>16: PV range alarm</p>  <p>(-10% FS max.) (+110% FS min.)</p>	<p>17: Instrument alarm (except for PV range alarm)</p> 	<p>18: Auto tuning status</p> 	<p>19: Manual status</p> 
<p>20: READY status</p> 	<p>21: Local status</p> 	<p>34: Presumed position execution status</p> 	<p>*1. Contents of process alarm</p> <p>This alarm is issued if a PV is kept <u>unchanged some time</u> after, although a manipulated variable exceeding <u>the set output</u> is sent. This is effective in EV1 to 3.</p> <ul style="list-style-type: none"> <li>• Set output = EV set value</li> <li>• Some time = EV on delay time</li> <li>• PV change = EV differential gap</li> </ul>	

32: *r-Lr* RSP tracking [ 0 ]  
 0: Not provided  
 1: Provided.

When "1" (provided) is selected, the current RSP value is written as an LSP during selection of LSP from RSP. When 8 LSPs are set in the LSP setting system of C16, the current RSP value is written in the LSP of the number selected at that time.

Even in the internal cascade model, the I-RSP value is written in S-LSP at that time.

33: *SPU* LSP up ramp [0U]  
 (SP1/main side in the internal cascade model)  
 0 to 26000U (ramp is not provided at 0U)

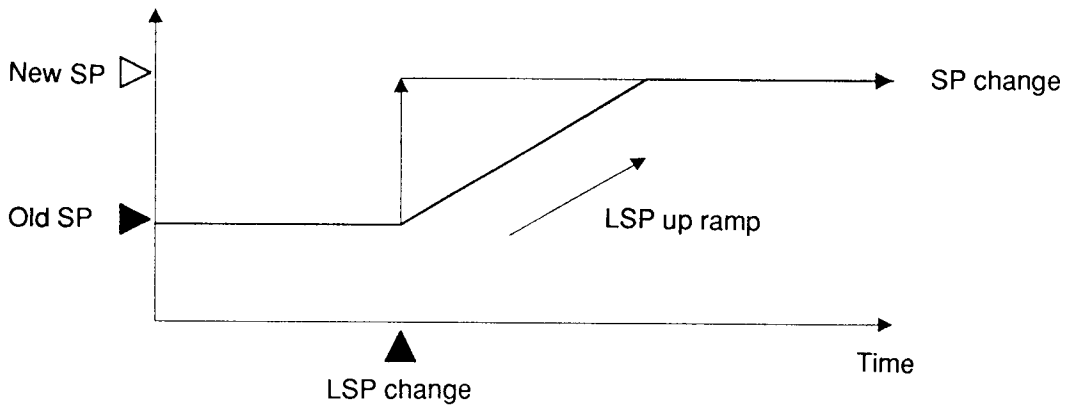

In the following case, PV tracking action is performed, using the present PV value instead of the old SP.

- When the power supply is turned on.
- When READY is changed to RUN.
- When MANUAL is changed to AUTO.

34: *SPd* LSP down ramp [0U]  
 (SP1/main side in the internal cascade model)  
 0 to 26000U (ramp is not provided at 0U)

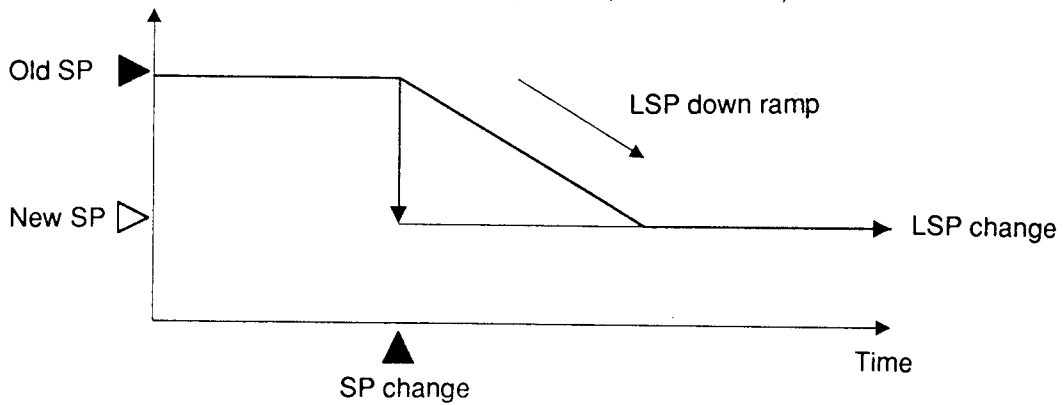

PV tracking action is executed with the same contents as *SPU*.

35: *rSPU*

RSP up ramp  
(SP2/slave side in the internal cascade model)  
0 to 26000U

[0U]

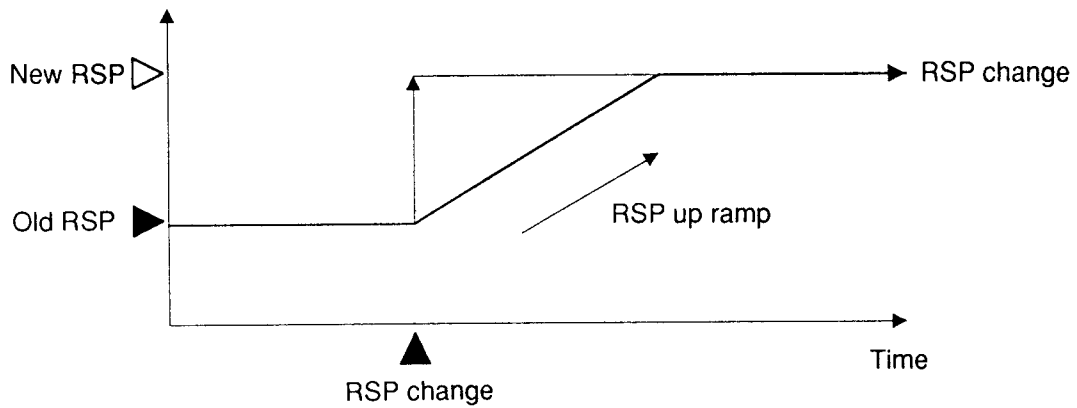

PV tracking action is executed with the same contents as *SPU*.

36: *rSPd*

RSP down ramp  
(SP2/slave side in the internal cascade model)  
0 to 26000U

[0U]

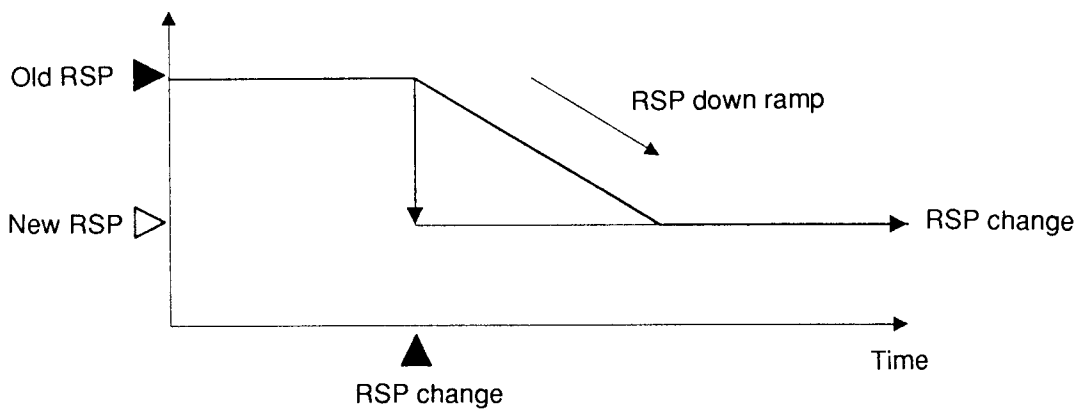

PV tracking action is executed with the same contents as *SPU*.

37: *rR-E*

SP ramp unit setting  
0: U/min  
1: 0.1U/min  
2: U/h  
3: 0.1U/h

[ 0 ]

This setting is effective in common to the LSP and RSP up/down set values. 0.1U means 1/10 of the minimum resolution of the relevant SP including the decimal point.

38:	<b>g. b. - L</b>	Low limit of green belt 0 to 200U	[50U]
39:	<b>g. b. - H</b>	High limit of green belt 0 to 200U	[50U]

These parameters set the high and low limits of stability when used as an OK lamp (C7=1) to monitor the control status of the instrument.

40:	<b>Π. - C</b>	Selection of motor control method 0: MFB control (conventional type) + Presumed position control 1: MFB control (conventional type) only 2: Presumed position control (without MFB) only	[ 0 ]
-----	---------------	---	-------

**[0]:** MFB control + Presumed position control

- When the MFB (Motor Feed Back) input is normal, the motor position is controlled by MFB being measured. While an MFB value is indicated in No. 2 indicator (lower stage), [**Fb**] lights in No. 3 indicator (FUNC).
- If the MFB input is abnormal, the motor position is controlled by the presumed MFB value. This status is called a presumed position control status. While an MFB value is indicated in No. 2 indicator, [**Fb**] flashes in No. 3 indicator. For example, if the motor rotates to a deterioration position of the motor feedback potential, the MFB input changes suddenly. This sudden change is detected as an error, and the proper position of MFB is presumed. Even when an MFB disconnection alarm occurs, the motor position is controlled by the presumed MFB value.
- In the presumed position control status, an error between the actual opening of the motor and the presumed MFB value is increased step by step unavoidably. Therefore, the close side relay is normally turned on when MV (output) ≤ 0.0%, and the open side relay is normally turned on when MV ≥ 100.0 to correct an error in the fully closed status or fully open status of the motor. However, if MV is controlled within the range of 0.1 to 99.9% by an output limiter, or MV is neither 0.0% or less, nor 100.0% or more according to a control status, this correction cannot be done.
- Even in the presumed control status, an event, auxiliary output and others are calculated on the base of a presumed MFB value.
- The following causes for setting of a presumed position control status are considered:
  - The motor opening adjustment is incomplete.
  - the deterioration resolution of feedback potential is insufficient.
  - MFB connection is wrong.

**[1]:** MFB control (conventional type)

- The motor control method used conventionally. When an MFB disconnection alarm occurs, the MFB value is regarded as 150.0% and the closed side relay is normally turned on.

**[2]:** Presumed position control (without MFB)

- The presumed position control is normally used as a motor control method. The motor position is controlled by the presumed MFB value regardless of MFB connection.





- Error processing in automatic adjustment
    - If MFB is disconnected, [15000] is written in each case of full close and full open.
    - In the primary case, the normal end is not executed as error processing, but the set values at delivery from the factory are restored, and "AL2" is indicated. "AL2" is cleared only when the automatic adjustment repeated again ends normally or the power supply is reset.
- [ (Full close count) – (Full open count) < 500 ]
- [ (Full close count) > (Full open count) ]
- [The time required from full close to full open is less than 5 sec.]
- [MFB disconnection alarm (AL10, AL11) occurs continuously or frequently.]
- [The time required until the MFB count value is stabilized exceeds 5 min.]
- [Misconnection of MFB or open/close relay] (However, all misconnections cannot be detected as errors.)

42:	$\Pi$ -CL	Input with motor fully closed 0 to (Input with motor fully open – 500)	[1000]
43:	$\Pi$ -OP	Input with motor fully open (Input with motor fully closed + 500) to 10000	[9000]
44:	$\Pi$ -t	Motor full close – full open time 5.0 to 240.0 s	[30.0]

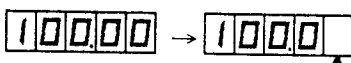

The above-mentioned three items are required to be set when the motor is adjusted manually. When [  $\Pi$ -C ] is "0" or "1" (MFB control is effective), all the three items can be set. When [  $\Pi$ -C ] is "2" (there is no MFB control), only the time of [  $\Pi$ -t ] can be set. In particular, when [  $\Pi$ -C ] is "2", the set time is used as the base for all operations. Measure the motor full close – full open time as accurately as possible up to the until of 0.1s and input the resultant value.

45:	dP	Indication 1 digit masking 0: Not provided. 1: Provided.	[ 0 ]
-----	----	--	-------

In the basic indication status, the least significant digit of each of PV, SP, DEV, RSP, PV2, SP2, and DEV2 is cleared from the LED indication.

Example:  →  Blank

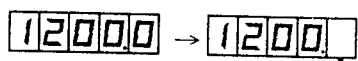
However, when this function is applied to an indication that includes one decimal digit as shown below, the decimal point cannot be erased because it is annexed to one digit.

 →  Blank

46:

Selection of auto tuning (AT) system

[ 0 ]

- 0: AT is not executed.
- 1: General AT is executed.
- 2: AT preventing overshoot is executed.
- 3: AT by neural net is executed.
- 4: In the internal cascade model, the slave side auto tuning is executed in the system 1 (general AT).

- In the auto tuning, the dead time and limit sensitivity of that system are found in any case by two limit cycles (with OL and OH of the selected current PID group used as a low limit and a high limit, respectively), and the PID values, etc. are calculated from their suitable characteristic expressions, and then the results are written. Auto tuning cannot be applied to all the heat/cool models in the standard model and remote SP model, or to the slave side of the heat/cool model in the internal cascade model (it can be applied to its master side as in the standard model, or the like). In the 0D and 6D models, the low limit output is 0%, and the high limit output is 100%.
- A PV fluctuates, depending upon an MV variation, during the execution of auto tuning. Before executing the auto tuning, make sure that the system does not cause an error due to this PV variation. Particularly, in the 5G and 2G models, the variation width of that PV can be limited by the OL and OH of a selected PID group. Therefore, in such a system that a large variation in PV is undesirable, set OL and OH near the expected design output at the set values to execute the auto tuning.
- Usually, suitable values are written by selecting "1" or "3" for this parameter. However, in a system which is liable to cause an overshoot, select "2" or use together the smart tuning for overshoot suppression control. When "3" is selected here, processing is executed by the neural net so that suitable values can be found for a wider range of applications as compared with the selection of "1" and "2". For the internal cascade model, first execute the auto tuning of the slave side in the local status by selecting "4", then execute that of the master side in the remote status by selecting any of "1" to "3".
- The output inversion (low limit ↔ high limit) points in auto tuning are determined from the SP and PV at the AT start as shown below. The SP at the AT start includes RSP, SP under ramp, and LSP shift as well.

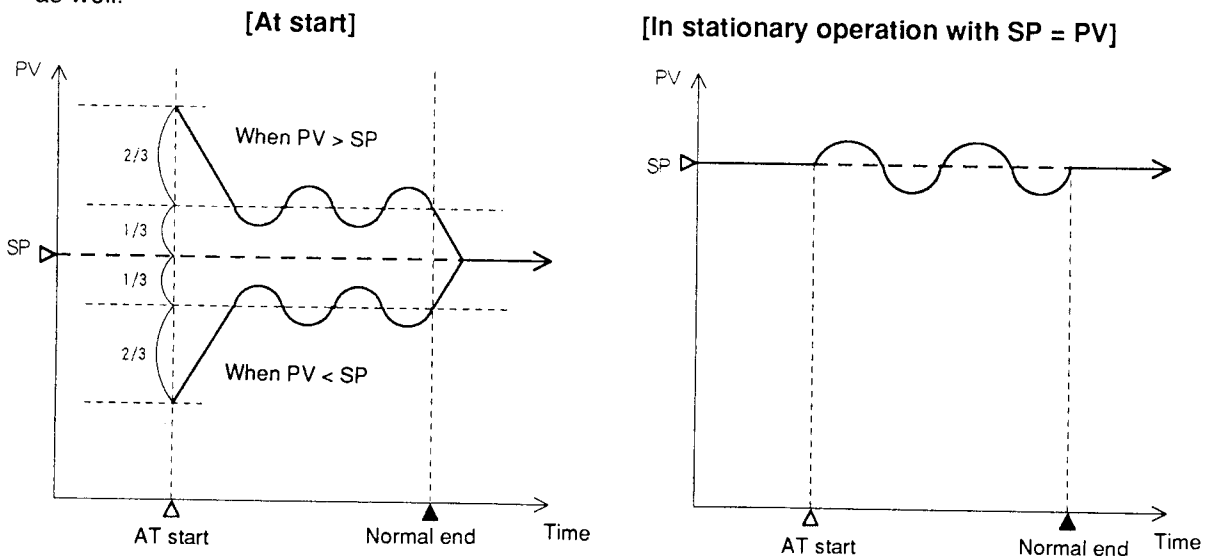



48: **2PI d**

Selection of 2 freedom degree PID

0: 2 freedom degrees are not used.

1: 2 freedom degrees are used.

- The 2 freedom degree PID function enhances the response to disturbance at setting without affecting the conventional rise (or fall) characteristic adversely. When the system "1" is selected, the optimum PID constants for response to disturbance can be set individually in addition to the conventional PID constants. These constants are set and stored automatically during the execution of auto tuning, and they can also be set and changed individually. In particular, when an MV variation is to be suppressed during setting in the 2G model to lessen the operation frequency of the motor and prolong its life, this function is effective by weakening the derivative of the PID for disturbance manually.
- These two kinds of PID can be changed over to each other manually by controlling the deviation and PV ramp, using the fuzzy rule.
- When I = 0 is set, the control action is executed without integral control action in any status regardless of the set value of dI for disturbance. In case of on-off control of P = 0.0, the disturbance response control cannot be selected.

49: **G-r**

Selection of 2 gain/RSP multi ratio

[ 0 ]

0: Both are not used.

1: The variable gain is used.

2: The RSP multi ratio is used.

(in the remote SP and internal cascade models only)

- It is selected whether either the variable gain or the RSP multi ratio (IRSP multi ratio in the internal cascade model) is to be set during setting of the parameters 50 to 58 given below. However, in case of the multi ratio, the number of settable ratios is seven, and they can be set only in the parameters 50 to 56.
- The gain has the same meaning as the inverse number of the proportional band P. When its numeric is increased, the sensitivity is enhanced, and the controllability is improved, but hunting is liable to be produced. When its numeric is reduced on the contrary, the sensitivity becomes dull.

$$\text{Real proportional band} = \text{Set proportional band} \times \frac{1}{\text{Gain value}}$$

- Any of the nine gain values [ **Gn-1** ] to [ **Gn-9** ] can be set according to the deviation width. For the real gain application, a value on the linear line connecting between the individual set points is used to smooth the control action. The gain at -20% is applied to a deviation of -20% max., and that at +20% is applied to a deviation of +20% min.

$$\text{Deviation} = \frac{\text{PV} - \text{SP}}{\text{Input range}} \quad (\text{reverse action})$$

$$\text{Deviation} = \frac{\text{SP} - \text{PV}}{\text{Input range}} \quad (\text{direct action})$$

- Example of broken line of gain :

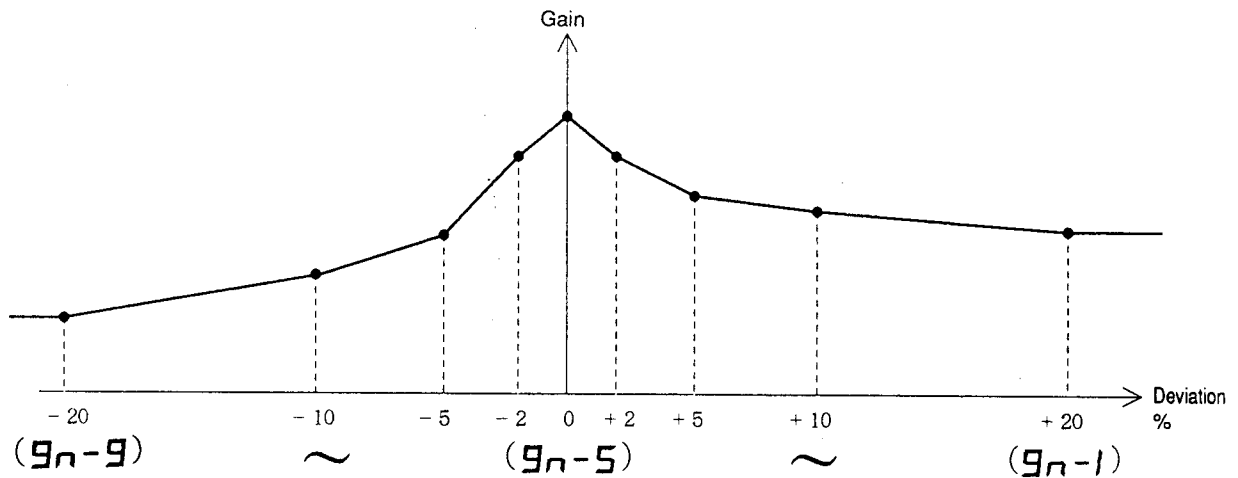

An abnormal point may be produced in the real proportional band and thereby the control action may be disturbed, depending upon the set value of gain, and the set proportional band. Therefore, be careful when the large set width of gain is to be selected.

- As for the RSP multi ratio, the following simple multiplication formula is obtained concerning the RSP in the remote SP model, or IRSP in the internal cascade model.

$$Y = X \times \text{Ratio set value}$$

where, Y: RSP (or IRSP) used for actual control

X: RSP (or main side MV) which is input to AI2

- The RSP multi ratio can be selected only by a remote switch. Unless selected, the RSP multi ratio is operated as 1.000. Particularly, in the remote SP model, the AI2 ratio is then effective.

50 :	<del>gn-1</del>	Gain 1 / (ratio 1)	[1.00 / (1.000) ]
51 :	<del>gn-2</del>	Gain 2 / (ratio 2)	[1.00 / (1.000) ]
52 :	<del>gn-3</del>	Gain 3 / (ratio 3)	[1.00 / (1.000) ]
53 :	<del>gn-4</del>	Gain 4 / (ratio 4)	[1.00 / (1.000) ]
54 :	<del>gn-5</del>	Gain 5 / (ratio 5)	[1.00 / (1.000) ]
55 :	<del>gn-6</del>	Gain 6 / (ratio 6)	[1.00 / (1.000) ]
56 :	<del>gn-7</del>	Gain 7 / (ratio 7)	[1.00 / (1.000) ]
57 :	<del>gn-8</del>	Gain 8	[1.00 ]
58 :	<del>gn-9</del>	Gain 9	[1.00 ]

Gain set range : 0.01 to 300.00

Ratio set range: 0.001 to 30.000

59 :	<i>t-A.1</i>	Input broken line approximation A1	[ 0 ]
60 :	<i>t-A.2</i>	Input broken line approximation A2	[1000 ]
	┌     ┐	┌     ┐	┌     ┐
69 :	<i>t-A.b</i>	Input broken line approximation A11	[1000 ]
70 :	<i>t-b.1</i>	Input broken line approximation B1	[ 0 ]
71 :	<i>t-b.2</i>	Input broken line approximation B2	[1000 ]
	┌     ┐	┌     ┐	┌     ┐
80 :	<i>t-b.b</i>	Input broken line approximation B11	[1000 ]
		An set range : -19999 to 26000U	
		Bn set range : -19999 to 26000U	

- Broken line approximation can be applied to the analog. Select AI1 or AI2 to be applied by setup C72, and set the broken line itself in the parameter 59 to 80. An denotes the input axis, while Bn denotes the output axis. For example, B<sub>1</sub> is output with respect to A<sub>1</sub> input, and a linear interpolation is applied between individual points. Both ends are fixed at (-20000U, -20000U) and (26000U, 26000U), respectively.
- In the broken line approximation operation, the input and output are set directly not in percent but in industrial unit. When linear scaling is permitted, the values after scaling are input.

[Input broken line approximation concept diagram]

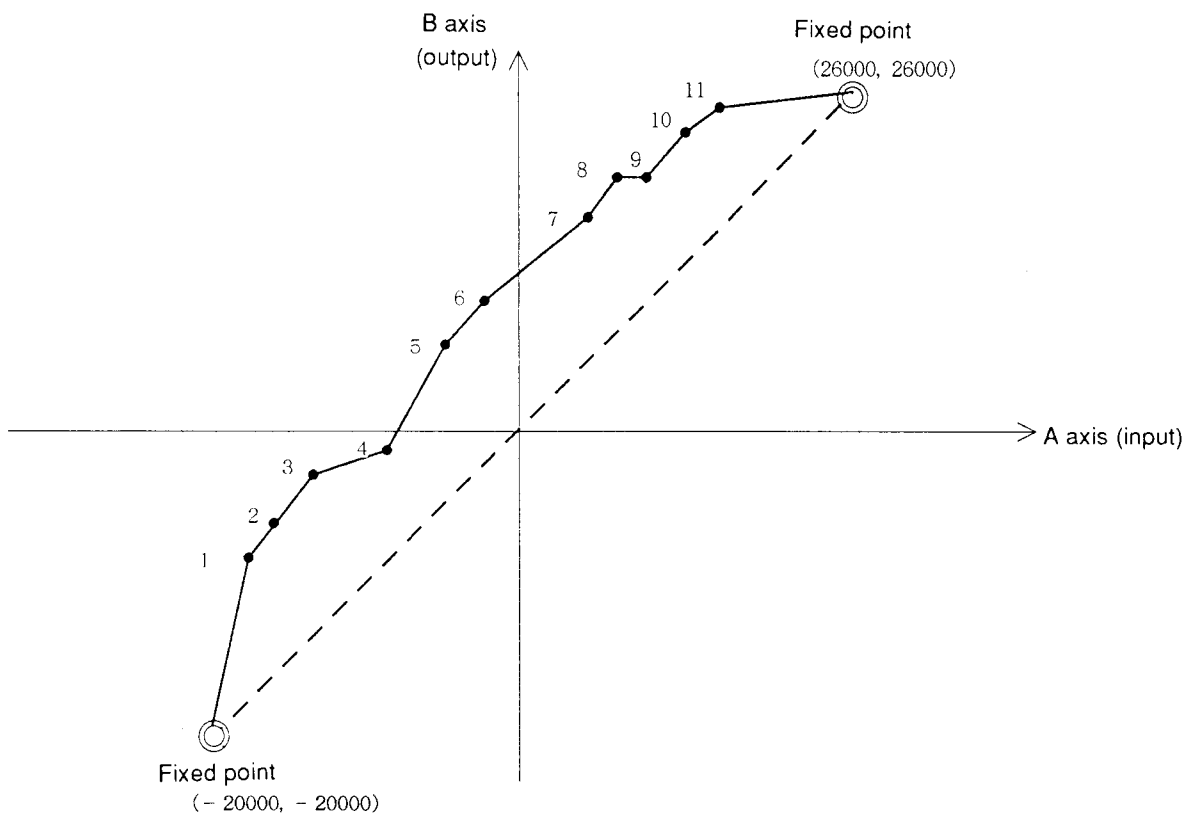

- Both  $A_n$  and  $B_n$  of a broken line are required to be set in the incremental direction as follows;

$$(A_1, B_1) = (0, 0), \quad (A_2, B_2) = (100, 100)$$

If a point on a broken line does not satisfy the incremental direction in its values, a broken line is produced with this point removed.

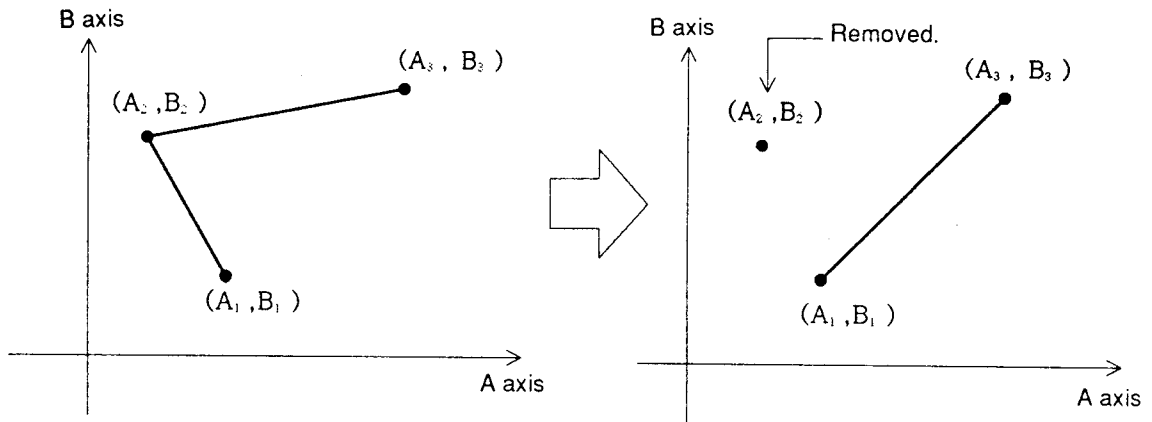

- If two points take the same value as to the A axis such as  $A_1 = A_2$ , the output value becomes  $B_1$ .

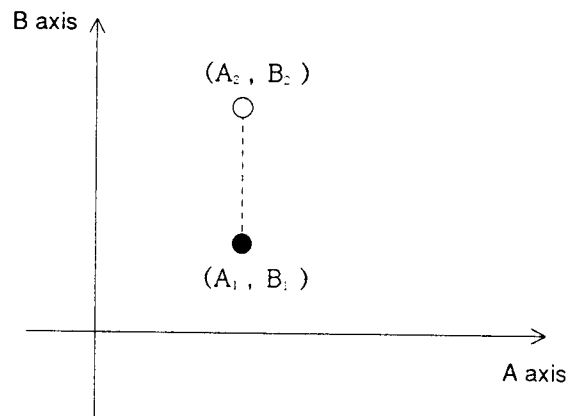

— MEMO —

# Chapter 6 SETTING OF PID ITEMS

## 6-1 PID Operation

### 1. Prior to setting

Up to eight PID groups can be set. Usually, the PID group assigned to the SP group is used in pair, but an arbitrary PID group can also be selected by a remote switch.

There are ten set items in one PID group; general PID, high and low limits of manipulated variable, manual reset, brake and PID for disturbance control. Although all set items can be set manually, the general PID and PID for disturbance control are found by the auto tuning, and stored automatically. When automatic rechecking setting for overshoot suppression is executed by the smart tuning, the brake value is also updated automatically according to the rise characteristic at every time. These tuning methods can be selected by setting the parameter Guide No. 46, 47 and 48.

### 2. How to set and reset the PID setting

The PID setting can be done in any mode (RUN/READY, AUTO/MAN and others) so far as the instrument is placed in the basic indication status.

In the basic indication status, a PV is indicated in No. 1 indicator, and an SP in No. 2 indicator. This status can be set by pressing the **DISP** key. Even when DEV or OUT is indicated in No. 2 indicator instead of the SP, the parameter setting mode can be set.

When the **PARA** key is pressed in the basic indication status, the following three setting groups can be called in turn. When the **ENT** key is pressed with **PID** indication, the PID item setting mode can be set.

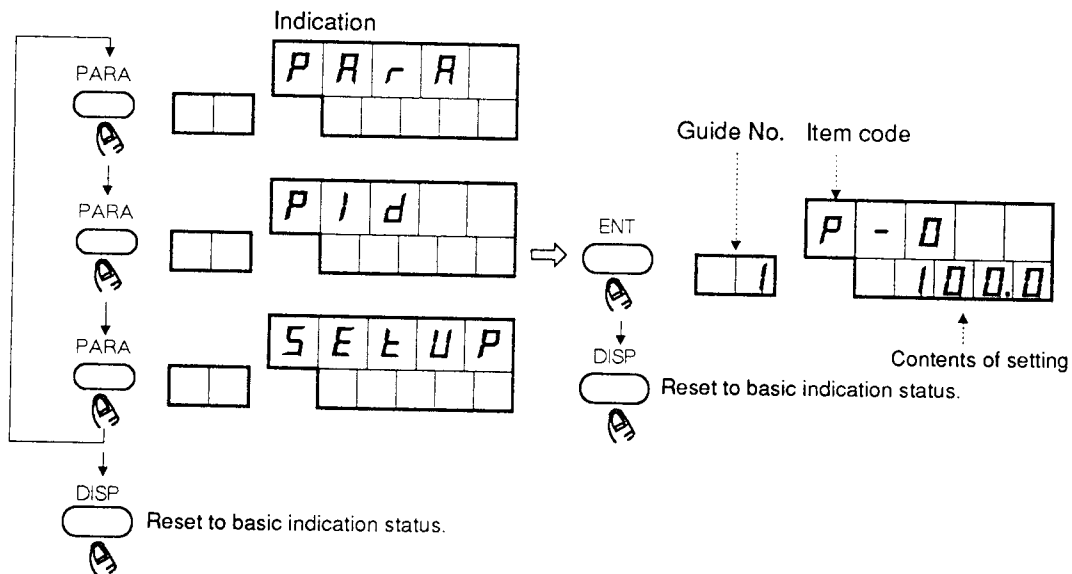



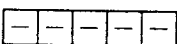

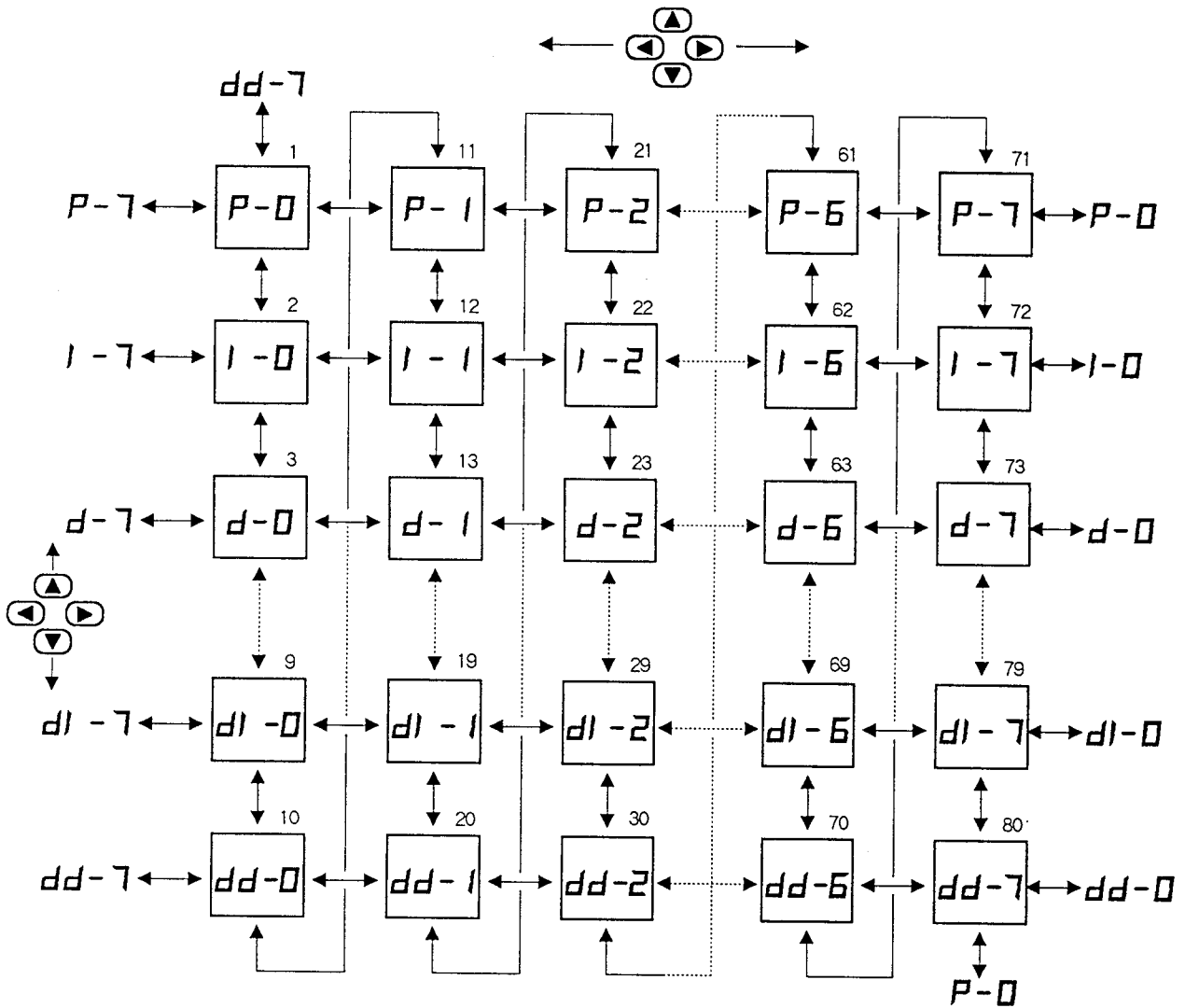
### 3. How to move the PID items

The PID items have a matrix construction like the two other setting groups. Each can be moved optionally with  keys as shown below. Unnecessary items are skipped, depending upon the model or the contents of setting.  is indicated in the No. 2 indicator for an unused item. The figure given at the right top of a frame of each item denotes Guide No.



### 4. How to change the set value of a PID item

To change the set value of a PID item, press the  key when this item is indicated. The set value on the No. 2 indicator flashes, indicating that it can be readily changed. Set a desired value with  keys, and press the  key. This value is stored, and flashing stops.

If the previous value is to be restored when the set value flashes, don't press the  key, but press the  key to reset to the basic indication status. Then, make the same setting operation.

6-2 PID Item Table

Guide No.	Item code	Item	Set value at delivery from factory	User's setting column	Setting
1	P-0	Proportional band	0	100.0	<p>Proportional band (P, dP): 0.0 to 1000.0% (0D, 6D), 0.1 to 1000.0% (5G, 2G, and 0D, 6D of heat/cool and internal cascade) In 0D and 6D, on-off control when set to 0.0. (dP is within 0.1 to 1000.0%)</p> <p>Integral time (I, dI): 0 to 3600s (dI is within 1 to 3600 sec). No integral action is provided at 0.</p> <p>Derivative time (d, dd): 0 to 1200s. No derivative action is provided at 0.</p> <p>Manual reset (rE): 0 to 100%. Indicated when P≠0 and I=0.</p> <p>Brake (br): 0 to 30. Brake function is stopped when set to 0. Overshoot suppression function is enhanced as numeric increases.</p> <p>Low-limit of manipulated variable (OL): -10% to high limit</p> <p>High-limit of manipulated variable (OH): Low limit to 110%</p> <p><b>Supplement</b></p> <ul style="list-style-type: none"> <li>This instrument has the two freedom degree PID control functions (selection). The optimum PID constants and the PID constants suitable for response to disturbance are set separately during setting change. It is automatically identified according to the current condition which PID constants are to be used, and automatic PID selection is executed by the instrument.</li> <li>PID constants for disturbance are also set automatically by auto tuning.</li> <li>If the numeric of the proportional band is made smaller, the controllability is enhanced, but an overshoot or hunting is liable to be produced, and the life of the actuator such as the modutrol motor may be shortened. Therefore, be careful not to make this value too small.</li> </ul>
2	I-0	Integral time	0	0	
3	d-0	Derivative time	0	0	
4	oL-0	Low-limit of manipulated variable	0	0	
5	oH-0	High-limit of manipulated variable	0	100	
6	rE-0	Manual reset	0	50	
7	br-0	Brake	0	0	
8	dP-0	Disturbance control proportional band	0	100.0	
9	dI-0	Disturbance control integral time	0	120	
10	dd-0	Disturbance control derivative time	0	0	
11	P-1	Proportional band	1	100.0	
12	I-1	Integral time	1	0	
13	d-1	Derivative time	1	0	
14	oL-1	Low-limit of manipulated variable	1	0	
15	oH-1	High-limit of manipulated variable	1	100	
16	rE-1	Manual reset	1	50	
17	br-1	Brake	1	0	
18	dP-1	Disturbance control proportional band	1	100.0	
19	dI-1	Disturbance control integral time	1	120	
20	dd-1	Disturbance control derivative time	1	0	
21	P-2	Proportional band	2	100.0	
22	I-2	Integral time	2	0	
23	d-2	Derivative time	2	0	
24	oL-2	Low-limit of manipulated variable	2	0	
25	oH-2	High-limit of manipulated variable	2	100	
26	rE-2	Manual reset	2	50	
27	br-2	Brake	2	0	
28	dP-2	Disturbance control proportional band	2	100.0	
29	dI-2	Disturbance control integral time	2	120	
30	dd-2	Disturbance control derivative time	2	0	

Guide No.	Item code	Item		Set value at delivery from factory	User's setting column	Setting
31	P-3	Proportional band	3	100.0		<ul style="list-style-type: none"> <li>• When a smaller numeric is set as the integral time, the follow-up ability is enhanced, but cycling, or the like is liable to be caused by the integral action.</li> <li>• <i>br</i>, <i>dP</i>, <i>dI</i>, and <i>dd</i> may not be indicated, unless selection is appropriate.</li> <li>• When a larger numeric is set as the derivative time, an overshoot or the like is easy to suppress, but hunting or the like is liable to be caused by quick response to a minor action. Generally, the appropriate derivative time in the normal temperature control is considered to be within 1/3 to 1/4 of the integral time. Since the derivative action tends to cause hunting or the like in the pressure or flowrate control, it is not done at all, or scarcely done in many cases.</li> <li>• As a larger numeric is set as the brake, the overshoot suppression effect is enhanced, but the rise time becomes longer on the contrary.</li> <li>• The high limit and low limit of manipulated variable not only restrict the control output, but also limit the output amplitude during auto tuning. These limit values have no effect in the manual mode. Even in the 0D, 6D and heat/cool models, the manipulated variable can be set within -10 to 110%. However, it is regarded as 0% between -10 and 0%, and as 100% between 100 and 110%.</li> <li>• PID No. 1 to 7 only can be selected by remote switches, but PID No. 0 cannot be selected by them. When all the contacts of the remote switches assigned are open, the PID number in pair with an SP is used.</li> <li>• When I=0 is set, control is executed without integral action at each time of rise, and response to disturbance irrespective of the set contents of dI.</li> </ul>
32	I-3	Integral time	3	0		
33	d-3	Derivative time	3	0		
34	oL-3	Low-limit of manipulated variable	3	0		
35	oH-3	High-limit of manipulated variable	3	100		
36	rE-3	Manual reset	3	50		
37	br-3	Brake	3	0		
38	dP-3	Disturbance control proportional band	3	100.0		
39	dI-3	Disturbance control integral time	3	120		
40	dd-3	Disturbance control derivative time	3	0		
41	P-4	Proportional band	4	100.0		
42	I-4	Integral time	4	0		
43	d-4	Derivative time	4	0		
44	oL-4	Low-limit of manipulated variable	4	0		
45	oH-4	High-limit of manipulated variable	4	100		
46	rE-4	Manual reset	4	50		
47	br-4	Brake	4	0		
48	dP-4	Disturbance control proportional band	4	100.0		
49	dI-4	Disturbance control integral time	4	120		
50	dd-4	Disturbance control derivative time	4	0		
51	P-5	Proportional band	5	100.0		
52	I-5	Integral time	5	0		
53	d-5	Derivative time	5	0		
54	oL-5	Low-limit of manipulated variable	5	0		
55	oH-5	High-limit of manipulated variable	5	100		
56	rE-5	Manual reset	5	50		
57	br-5	Brake	5	0		
58	dP-5	Disturbance control proportional band	5	100.0		
59	dI-5	Disturbance control integral time	5	120		
60	dd-5	Disturbance control derivative time	5	0		

Guide No.	Item code	Item		Set value at delivery from factory	User's setting column	Setting
61	P-6	Proportional band	6	100.0		<ul style="list-style-type: none"> <li>• In the internal cascade model, the PID groups 0 to 5 are assigned to the master control side, and the PID groups 6 and 7 to the slave control side (LSP6, LSP7, RSP), and then the brake and disturbance control PID cannot be set in the slave control side PID groups 6 and 7.</li> <li>• In the internal cascade model, on-off control cannot be done on both master and slave control sides. When P=0.0% is set, it is regarded as P=0.1% during action.</li> <li>• The set values of the PID group at delivery from the factory are as shown below. <ul style="list-style-type: none"> <li>– Standard model and remote SP model ----- Both LSP0 to 7 and RSP: No. 0</li> <li>– Internal cascade model ----- LSP0 to 5 (M – LSP): No. 0 LSP6, 7: No. 6 I-RSP: No. 7</li> </ul> </li> </ul>
62	I-6	Integral time	6	0		
63	d-6	Derivative time	6	0		
64	oL-6	Low-limit of manipulated variable	6	0		
65	oH-6	High-limit of manipulated variable	6	100		
66	rE-6	Manual reset	6	50		
67	br-6	Brake	6	0		
68	dP-6	Disturbance control proportional band	6	100.0		
69	dI-6	Disturbance control integral time	6	120		
70	dd-6	Disturbance control derivative time	6	0		
71	P-7	Proportional band	7	100.0		
72	I-7	Integral time	7	0		
73	d-7	Derivative time	7	0		
74	oL-7	Low-limit of manipulated variable	7	0		
75	oH-7	High-limit of manipulated variable	7	100		
76	rE-7	Manual reset	7	50		
77	br-7	Brake	7	0		
78	dP-7	Disturbance control proportional band	7	100.0		
79	dI-7	Disturbance control integral time	7	120		
80	dd-7	Disturbance control derivative time	7	0		

### 6-3 Detailed Description of PID Items

In the cases of the standard model and heat/cool model with RSP, the PID groups are selected as shown in the table below.

Setting of PID groups of LSP0 to 7 and RSP	PID group used for heat control	PID group used for cool control
No. 0	No. 0	No. 1
No. 1	No. 2	No. 3
No. 2	No. 4	No. 5
No. 3	No. 6	No. 7

In the cases of the internal cascade heat/cool model, the PID groups are selected as shown in the tables below.

Setting of PID group of LSP0 to 5	PID group used for master side control
No. 0 to 5	As set to the left.

Setting of PID groups of internal RSP and LSP6 to 7	PID group used for heat control	PID group used for cool control
Setting is disabled.	No. 6	No. 7

# Chapter 7 SETTING OF SETUP ITEMS

## 7-1 Setup Operation

### 1. Prior to setup

After this instrument is built in an equipment for the first time, it is necessary to set the basic operation conditions for this instrument such as the input ranges, control actions, remote switch inputs and event outputs according to the equipment using methods.

This chapter provides descriptions on the setting of these basic operation conditions, which is called "setup". If the instrument has already been built in the equipment, and the setup has been completed, its resetting is not necessary.

There are about 40 to 90 setup items, which change, depending upon the model. There are also such setup items that the values set at delivery from the factory can be used as they are. To complete the setup items properly with no error in a short time, it is recommended to decide the setup values in advance, using the user's setting column, and perform the actual setup operation.

### 2. How to set and reset the setup setting mode



To set the setup setting mode, the key lock must be set to "0" without fail. The set values cannot be changed in any other mode than the READY. In not the READY mode but the RUN mode, the indications can be checked, but the ENT key does not function. However, in any status, the first setup item C1 "key lock" operation only can be done.

Press the DISP key to reset to the basic indication status in which a PV and an SP are indicated. When this status has been already set, the above-mentioned operation need not be done.

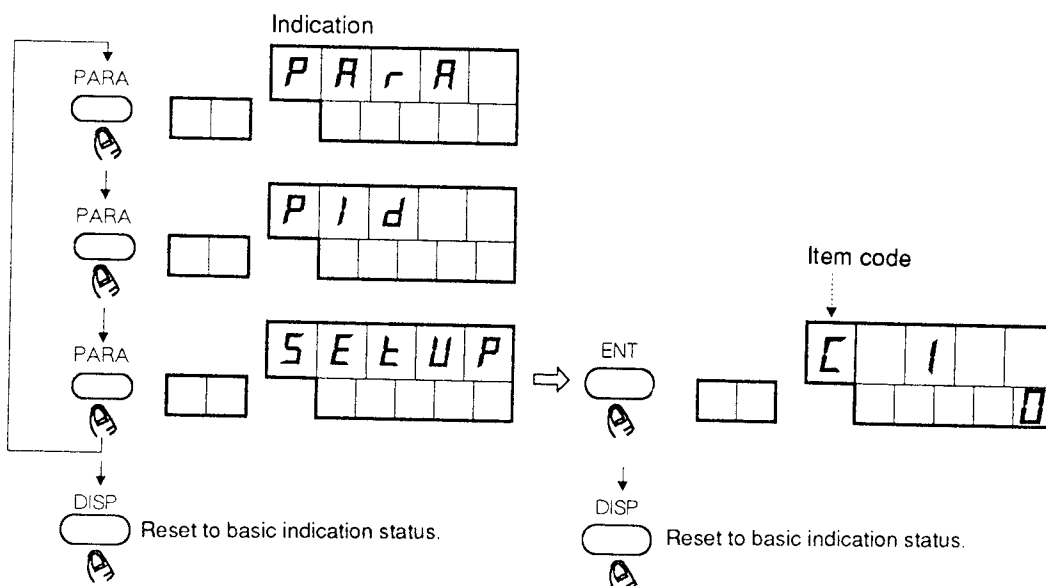
The following three setting groups can be called in turn by pressing the PARA key in the basic indication status. Press the ENT key with **SEtUP** indication to set the setup operation mode. Press the DISP key to reset the setup operation mode. In any status, the basic indication status can be restored.





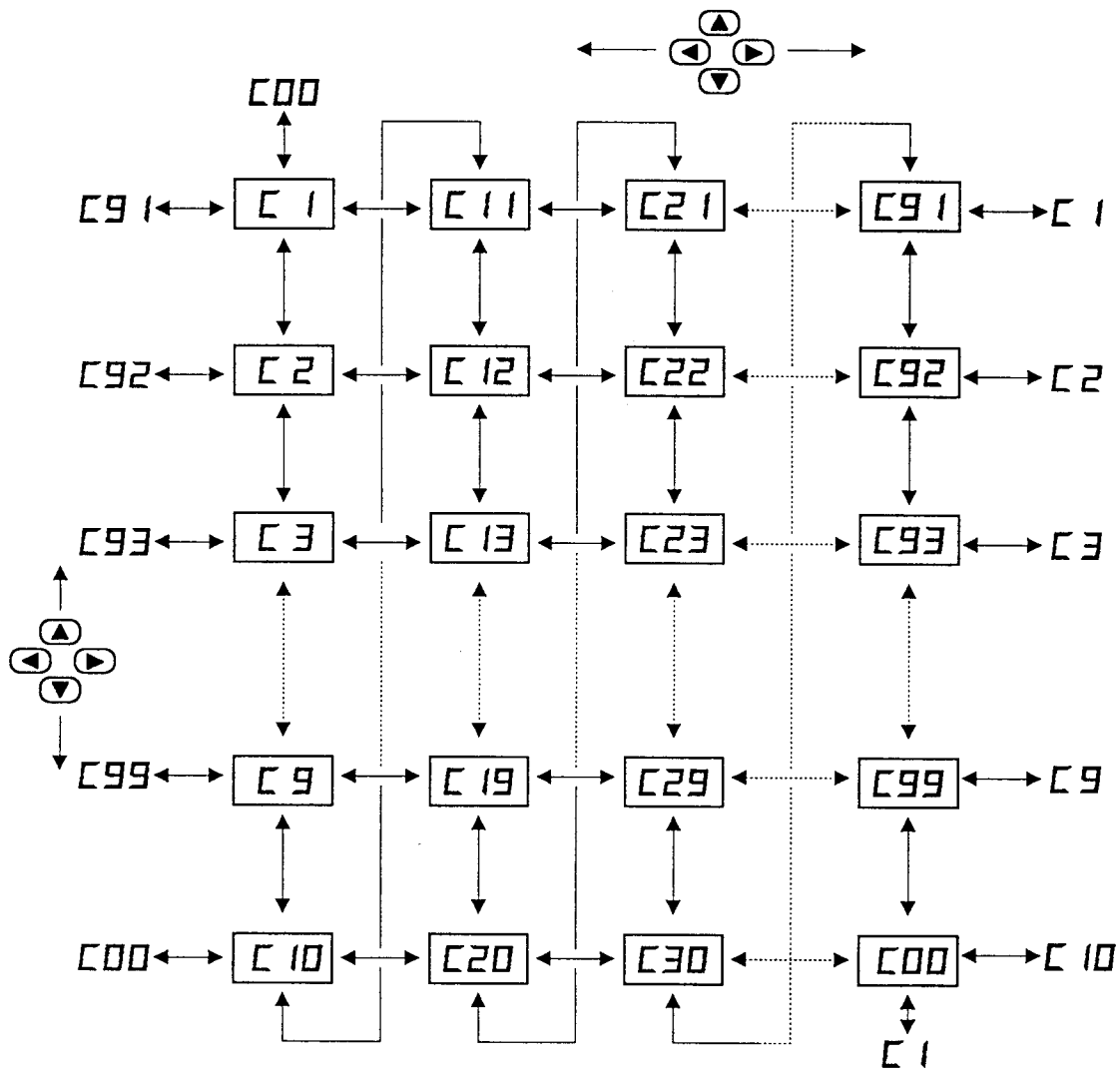

### 3. How to move a setup item

The setup items have a matrix construction like the two other setting groups. Each setup item can be moved optionally with  keys as shown below.  is indicated in the No. 2 indicator for an unnecessary item or unused item, depending upon the model or the contents of setting. The Guide No. is not indicated since it is the same as the setup item No.



### 4. How to change the set value of setup item

To change the set value of a setup item, press the  key, when this item is indicated. The set value on the No. 2 indicator flashes, indicating that it can be readily changed. Set a desired value with  keys, and press the  key. This value is stored, and flashing stops.

If the previous value is to be restored while the set value flashes, press not the  key, but press the  key to reset to the basic indication status. Then, make the same setting operation.

**7-2 Setup Item Table**

Guide No.	Item code	Item	Set value at delivery from factory	User's setting column	Setting
1	[ 1	Key lock	0		<p>0: Key lock is not provided.                      1: SETUP only cannot be changed, but the others can be changed.                      2: SETUP, PARA, and PID cannot be changed, but the others can be changed.                      3: SP/EV, SETUP, PARA and PID cannot be changed, but the others can be changed.                      4: DISP, UF1 and UF2 only can be changed, but the others cannot be changed.</p> <p><b>Supplement</b>                      The key lock itself can be changed in any status.</p>
2	[ 2	Control action (on the master side in the internal cascade model)	0		<p>0: Reverse action                      1: Direct action</p> <p><b>Supplement</b>                      Action change can be done by RSW.</p>
3	[ 3	Control action (on the slave side in the internal cascade model)	0		<p>0: Reverse action                      1: Direct action</p> <p><b>Supplement</b>                      Action change cannot be done by RSW.</p>
4	[ 4	Heat/cool output assignment	0		<p>0: Heat = MV1, Cool = MV2                      1: Heat = MV2, Cool = MV1</p>
5	[ 5	AI1 Temperature unit (analog input 1)	0		<p>0: °C                      1: °F</p>
6	[ 6	AI1 Input range type	0		<p>See the PV range number table (page 1-7, 1-8).</p> <p><b>Supplement</b>                      Full multi input type. However, the input connection must be changed, depending upon the input type.</p>

Guide No.	Item code	Item	Set value at delivery from factory	User's setting column	Setting
7	<b>C 7</b>	AI1 Linear input decimal point position	(Undefined)		0: X X X X X 1: X X X X.X 2: X X X.X X 3: X X.X X X 4: X.X X X X
8	<b>C 8</b>	AI1 Linear input low limit (0%)	(Undefined)		-19999 to 26000U
9	<b>C 9</b>	AI1 Linear input high limit (100%)	(Undefined)		-19999 to 26000U  <b>Supplement</b> The numerics of C8 and C9 are free in magnitude relation.
10	<b>C 10</b>	AI1 Linear input square root operation and dropout	0.0		0.0: Square root operation is not provided. 0.1 to 10.0% FS: (Ratio to AI1 range) Square root operation is provided, and at the same time, a dropout value is set.
11	<b>C 11</b>	AI2 (analog input 2) Input type	0		0: 4 to 20mA 1: 1 to 5V  <b>Supplement</b> AI2 functions as an RSP in the remote SP model, or as a PV2 in the internal cascade model.
12	<b>C 12</b>	AI2 Decimal point position	0		0: X X X X X 1: X X X X.X 2: X X X.X X 3: X X.X X X 4: X.X X X X  <b>Supplement</b> This can be set only in the internal cascade model.
13	<b>C 13</b>	AI2 Input low limit	0		-19999 to 26000U

Guide No.	Item code	Item	Set value at delivery from factory	User's setting column	Setting
14	<b>C 14</b>	AI2 Input high limit	10000		-19999 to 26000U <b>Supplement</b> The numerics of C13 and C14 are free in magnitude relation.
15	<b>C 15</b>	AI2 Square root operation and dropout	0.0		0.0: Square root operation is not provided. 0.1 to 10.0% FS: Square root operation is provided, and at the same time, a dropout value is set.
16	<b>C 16</b>	LSP setting system	0		0: Only one LSP is used. Usually, an SP value is changed. 1: Only one LSP is used. An SP value is directly changed. 2: 8 LSPs are used. An SP value and PID group can be changed. 3: 8 LSPs are used. An SP value and PID group cannot be changed. <b>Supplement</b> If an RSW is not assigned for the LSP selection in the above-mentioned "2" and "3", 8 LSPs can be selected from the console. When an RSW is assigned, the console operation is ineffective, and the RSW has priority. In the internal cascade model, this setup item is effective only on the master side, using not 8 but 6 LSPs (0 to 5).
17	<b>C 17</b>	Low limit of SP limit	-19999		-19999U to High limit
18	<b>C 18</b>	High limit of SP limit	26000		Low limit to 26000U <b>Supplement</b> C17 and C18 are shared by LSP and RSP, and their limit ranges are the same. In the internal cascade model, they are effective only for the internal RSP. To assure safety, be sure to set necessary values as SP limits.
19	<b>C 19</b>	At AI overrange, Contents selection of control output (MV)	0		0: Not provided. 1: AI1 is over. 2: AI2 is over. 3: AI1 or AI2 is over.
20	<b>C 20</b>	At AI overrange, setting of control output quantity	0		-10 to 110%

Guide No.	Item code	Item	Set value at delivery from factory	User's setting column	Setting
21	<b>C21</b>	Manual change mode	0		0: Bumpless (the current output is held) 1: Preset  <div style="border: 1px solid black; padding: 2px; display: inline-block;">Supplement</div> This item is applied to the case where AUTO/MAN is selected by the console or RSW.
22	<b>C22</b>	Preset MANUAL value	0		-10 to 110%  <div style="border: 1px solid black; padding: 2px; display: inline-block;">Supplement</div> This setup is applied to the case where "1" is selected as C21. When power is recovered from failure during manual operation from the console, the C22 value is selected irrespective of C21 setting.
23	<b>C23</b>	Fixed value output 1	0		-10 to 110%  <div style="border: 1px solid black; padding: 2px; display: inline-block;">Supplement</div>
24	<b>C24</b>	Fixed value output 2	0		This setup can be controlled only by RSW. The priority is in the order of 1 > 2 > 3. "1" is highest in priority.
25	<b>C25</b>	Fixed value output 3	0		
26	<b>C26</b>	Setting of control output quantity in READY mode	0		-10 to 110%  <div style="border: 1px solid black; padding: 2px; display: inline-block;">Supplement</div> This setup item functions as a control output on the cool side in the READY mode of the heat/cool model.
27	<b>C27</b>	Setting of cool side control output quantity in READY mode	0		-10 to 110%  <div style="border: 1px solid black; padding: 2px; display: inline-block;">Supplement</div> This setup item functions as a control output on the heat side in the READY mode of the heat/cool model.
28	<b>C28</b>	Event in READY mode	0		0: Acts even in READY mode. 1: Does not act in READY mode.

Guide No.	Item code	Item	Set value at delivery from factory	User's setting column	Setting																					
29	<b>C29</b>	Setting of internal RSP 0% (internal cascade model)	0		-19999 to 26000U																					
30	<b>C30</b>	Setting of internal RSP 100% (internal cascade model)	10000		-19999 to 26000U  <b>Supplement</b> The numerics of C29 and C30 are free in magnitude relation.																					
31	<b>C31</b>	AI1 and AI2 exchange  (Internal cascade model)	0		0: Not exchanged. (AI1 = PV for master, AI2 = PV for slave) 1: Exchanged. (AI1 = PV for slave, AI2 = PV for master)  <b>Supplement</b> In the internal cascade model, it is selected whether each input of AI1 and AI2 is assigned as a PV for master control, or as a PV for slave control.																					
32	<b>C32</b>	Type of auxiliary output 1 (AUX1)	0		0: PV 1: SP 2: DEV 3: MV 4: RSP 5: Motor opening (MFB)  <table border="1" style="display: inline-table; vertical-align: middle;"> <tr><td colspan="3">Internal cascade model</td></tr> <tr><td>0: PV1</td><td>6: PV2</td><td></td></tr> <tr><td>1: SP1</td><td>7: SP2</td><td></td></tr> <tr><td>2: DEV1</td><td>8: DEV2</td><td></td></tr> <tr><td>3: MV1</td><td>9: MV2</td><td></td></tr> <tr><td>4: .....</td><td>10: I-RSP</td><td></td></tr> <tr><td>5: MFB</td><td></td><td></td></tr> </table>	Internal cascade model			0: PV1	6: PV2		1: SP1	7: SP2		2: DEV1	8: DEV2		3: MV1	9: MV2		4: .....	10: I-RSP		5: MFB		
Internal cascade model																										
0: PV1	6: PV2																									
1: SP1	7: SP2																									
2: DEV1	8: DEV2																									
3: MV1	9: MV2																									
4: .....	10: I-RSP																									
5: MFB																										
33	<b>C33</b>	Auxiliary output 1 4mA setting	0		-19999 to 26000U -1999.9 to 2600.0% (MV, motor opening)																					
34	<b>C34</b>	Auxiliary output 1 20mA setting	10000		-19999 to 26000U -1999.9 to 2600.0% (MV, motor opening)  <b>Supplement</b> The numerics of C34 and C35 are free in magnitude relation.																					

Guide No.	Item code	Item	Set value at delivery from factory	User's setting column	Setting																					
35	<b>C35</b>	Auxiliary output 1 Output in READY mode	0		0: Bumpless (the current output is held) 1: Preset																					
36	<b>C36</b>	Auxiliary output 1 Setting of preset output quantity in READY mode	0		-19999 to 26000U -1999.9 to 2600.0% (MV, motor opening)																					
37	<b>C37</b>	Type of auxiliary output 2 (AUX2)	0		<table border="0"> <tr> <td>0: PV</td> <td colspan="2">Internal cascade model</td> </tr> <tr> <td>1: SP</td> <td>0: PV1</td> <td>6: PV2</td> </tr> <tr> <td>2: DEV</td> <td>1: SP1</td> <td>7: SP2</td> </tr> <tr> <td>3: MV</td> <td>2: DEV1</td> <td>8: DEV2</td> </tr> <tr> <td>4: RSP</td> <td>3: MV1</td> <td>9: MV2</td> </tr> <tr> <td>5: Motor opening (MFB)</td> <td>4: .....</td> <td>10: I-RSP</td> </tr> <tr> <td></td> <td>5: MFB</td> <td></td> </tr> </table>	0: PV	Internal cascade model		1: SP	0: PV1	6: PV2	2: DEV	1: SP1	7: SP2	3: MV	2: DEV1	8: DEV2	4: RSP	3: MV1	9: MV2	5: Motor opening (MFB)	4: .....	10: I-RSP		5: MFB	
0: PV	Internal cascade model																									
1: SP	0: PV1	6: PV2																								
2: DEV	1: SP1	7: SP2																								
3: MV	2: DEV1	8: DEV2																								
4: RSP	3: MV1	9: MV2																								
5: Motor opening (MFB)	4: .....	10: I-RSP																								
	5: MFB																									
38	<b>C38</b>	Auxiliary output 2 4mA setting	0		-19999 to 26000U -1999.9 to 2600.0% (MV, motor opening)																					
39	<b>C39</b>	Auxiliary output 2 20mA setting	10000		-19999 to 26000U -1999.9 to 2600.0% (MV, motor opening)  <div style="border: 1px solid black; padding: 2px; display: inline-block;">Supplement</div> The numerics of C39 and C40 are free in magnitude relation.																					
40	<b>C40</b>	Auxiliary output 2, Output in READY mode	0		0: Bumpless (the current output is held) 1: Preset																					
41	<b>C41</b>	Auxiliary output 2, Setting of preset output quantity in READY mode	0		-19999 to 26000U -1999.9 to 2600.0% (MV, motor opening)																					

Guide No.	Item code	Item	Set value at delivery from factory	User's setting column	Setting	
42	C42	RSW1 assignment	0		<u>ON (contact closed time)</u>	<u>OFF (contact open time)</u>
43	C43	RSW2 assignment	0		0: NOP (non-action)	—
44	C44	RSW3 assignment	0		1: READY	RUN
45	C45	RSW4 assignment	0		2: MANUAL	AUTO
46	C46	RSW5 assignment	0		3: REMOTE	LOCAL (LSP)
47	C47	RSW6 assignment	0		4: Auto Tuning (AT) start	AT stop (during AT)
48	C48	RSW7 assignment	0		5: Inversion of control action	As set to C2.
49	C49	RSW8 assignment	0		6: —	—
50	C50	RSW9 assignment	0		7: —	—
51	C51	RSW10 assignment	0		8: —	—
52	C52	RSW11 assignment	0		9: —	—
53	C53	RSW12 assignment	0		10: LSP number selection 2 <sup>0</sup> (+1)	0
					11: LSP number selection 2 <sup>1</sup> (+2)	0
					12: LSP number selection 2 <sup>2</sup> (+4)	0
					13: PID number selection 2 <sup>0</sup> (+1)	0
					14: PID number selection 2 <sup>1</sup> (+2)	0
					15: PID number selection 2 <sup>2</sup> (+4)	0
					16: S-LSP 7	S-LSP 6
					17: Fixed value output 1	—
					18: Fixed value output 2	—
					19: Fixed value output 3	—
					20: LSP shift selection 2 <sup>0</sup> (+1)	0
					21: LSP shift selection 2 <sup>1</sup> (+2)	0
					22: LSP shift selection 2 <sup>2</sup> (+4)	0
					23: LSP shift selection 2 <sup>3</sup> (+8)	0
					24: LSP shift selection 2 <sup>4</sup> (+16)	0
					25: LSP shift selection 2 <sup>5</sup> (+32)	0
					26: LSP shift selection 2 <sup>6</sup> (+64)	0
					27: LSP shift selection 2 <sup>7</sup> (+128)	0
					28: LSP shift selection 2 <sup>8</sup> (+256)	0
					29: LSP shift selection 2 <sup>9</sup> (+512)	0
					30: RSP ratio number selection 2 <sup>0</sup> (+1)	0
					31: RSP ratio number selection 2 <sup>1</sup> (+2)	0
					32: RSP ratio number selection 2 <sup>2</sup> (+4)	0
					33: Computer backup system 1 (through output)	Backup (LSP is PV)
					34: Computer backup system 2 (through output)	Backup (LSP is preset)

**Supplement**

- " — " denotes that there is no effect on operation.
- If "1: RUN/READY" is assigned to an RSW, and that RSW is then open, the RUN mode is set forcibly. Therefore, the following setup operation cannot be done. To continue the setup operation, the RSW must be closed once to restore the READY mode.
- To assign "33" or "34" to an RSW, be sure to set "1" in C75.

Guide No.	Item code	Item	Set value at delivery from factory	User's setting column	Setting																		
54	<b>C54</b>	LSP shift width by RSW	0		-10000 to 10000U <b>Supplement</b> The actual shift quantity is the product of this LSP shift width and the total of the LSP shift numbers assigned to RSWs.																		
55	<b>C55</b>	UF1 key basic register	0		0: Not registered. 1: AUTO/MAN 2: REM/LOC 3: AT 4: RUN/READY 5: Selected from among SP, EV, PARA, PID and SETUP items. <b>Supplement</b> Only one function can be registered in the UF1 to assign "1" to "4". When "5" is assigned, up to four items of C56 to C59 can be registered in the UF1 key.																		
56	<b>C56</b>	UF1 assigned content 1	0		When C55 = 5, the Guide No. of each set group to be registered plus the following radix are to be set to this setup item.  <table style="margin-left: auto; margin-right: auto;"> <tr> <td style="padding-right: 20px;">Item</td> <td style="padding-right: 20px;">Radix</td> <td></td> </tr> <tr> <td>SP</td> <td>:</td> <td>+4000</td> </tr> <tr> <td>EV</td> <td>:</td> <td>+4500</td> </tr> <tr> <td>PID</td> <td>:</td> <td>+5000</td> </tr> <tr> <td>PARA</td> <td>:</td> <td>+5500</td> </tr> <tr> <td>SETUP</td> <td>:</td> <td>+6000</td> </tr> </table>	Item	Radix		SP	:	+4000	EV	:	+4500	PID	:	+5000	PARA	:	+5500	SETUP	:	+6000
Item	Radix																						
SP	:	+4000																					
EV	:	+4500																					
PID	:	+5000																					
PARA	:	+5500																					
SETUP	:	+6000																					
57	<b>C57</b>	UF1 assigned content 2	0																				
58	<b>C58</b>	UF1 assigned content 3	0																				
59	<b>C59</b>	UF1 assigned content 4	0																				
					<b>Supplement</b> For example, to register LSP0 in UF1, set 4002 (SP radix + Guide No. of LSP0 value = 4000 + 2 = 4002) to one of C56 to 59. If an in-existent number is set to this setup item, it is ineffective. For example, 0 is an in-existent number set at delivery from the factory. Therefore, it is ineffective, and it is not registered in the UF1 key.																		

Guide No.	Item code	Item	Set value at delivery from factory	User's setting column	Setting												
60	<b>C60</b>	UF2 key basic register	0		<p>0: Not registered.                      1: AUTO/MAN                      2: REM/LOC                      3: AT                      4: RUN/READY                      5: Selected from among SP, EV, PARA, PID and SETUP items.</p> <p><b>Supplement</b>                      Only one function can be registered in the UF2 to assign "1" to "4".                      When "5" is assigned, up to eight items of C61 to C68 can be registered in the UF1 key.                      The same contents can be assigned doubly between the UF1 and UF2 keys.</p>												
61	<b>C61</b>	UF2 assigned content 1	0		<p>When C60 = 5, the Guide No. of each set group to be registered plus the following numeric are to be set to this setup item.</p> <table border="0"> <tr> <td>Set group</td> <td>Addend</td> </tr> <tr> <td>SP</td> <td>: +4000</td> </tr> <tr> <td>EV</td> <td>: +4500</td> </tr> <tr> <td>PID</td> <td>: +5000</td> </tr> <tr> <td>PARA</td> <td>: +5500</td> </tr> <tr> <td>SETUP</td> <td>: +6000</td> </tr> </table> <p><b>Supplement</b>                      If an inexistent number is set to this setup item, it is ineffective. For example, 0 is an inexistent number set at delivery from the factory. Therefore, it is ineffective, and it is not registered in the UF2 key.</p>	Set group	Addend	SP	: +4000	EV	: +4500	PID	: +5000	PARA	: +5500	SETUP	: +6000
Set group	Addend																
SP	: +4000																
EV	: +4500																
PID	: +5000																
PARA	: +5500																
SETUP	: +6000																
62	<b>C62</b>	UF2 assigned content 2	0														
63	<b>C63</b>	UF2 assigned content 3	0														
64	<b>C64</b>	UF2 assigned content 4	0														
65	<b>C65</b>	UF2 assigned content 5	0														
66	<b>C66</b>	UF2 assigned content 6	0														
67	<b>C67</b>	UF2 assigned content 7	0														
68	<b>C68</b>	UF2 assigned content 8	0														
69	<b>C69</b>	Basic register of UF LED indication	0		<p>0: Not registered (does not light).                      1: Lights when registered in the UF1 or UF2 key.                      2: Selected from EV (lights when event ON).                      3: Selected from RSW (lights when RSW ON).</p> <p><b>Supplement</b>                      When "2" or "3" is assigned in this setup, its contents are registered in C70.</p>												

Guide No.	Item code	Item	Set value at delivery from factory	User's setting column	Setting
70	<b>C70</b>	Assigned contents of UF LED indication	0		When C69=2, 1 to 8 (Event number) When C69=3, 1 to 12 (RSW number)
71	<b>C71</b>	Selection of indication contents of bar graph indicator	0		0: Control output quantity (final output) monitor 1: OK lamp (green belt) 2: Motor opening monitor (only with 2G output provided) 3: Event monitor (4 to 8) 4: RSW monitor (1 to 12)
72	<b>C72</b>	Input broken line approximation	0		0: Not used. 1: Used for AI1. 2: Used for AI2.  <b>Supplement</b> A broken line is set in PARA 59 to 80.
73	<b>C73</b>	Unused	--		
74	<b>C74</b>	Unused	--		
75	<b>C75</b>	RSP, C/B selection	0		0: RSP 1: C/B (computer backup)  <b>Supplement</b> When the computer backup system is selected in RSW assignment, be sure to set "1" in this setup.
76	<b>C76</b>	Selection of output system of time proportional output	0		0: Turned on again in the cycle. 1: Not turned on again in the cycle (normal output system).  <b>Supplement</b> "0" has effect on improvement of the controllability when the cycle time is long. In the heat/cool model, the same contents are applied to the cool side as well.
77	<b>C77</b>	Compensation of thermocouple cold junction	0		0: Internal 1: External

Guide No.	Item code	Item	Set value at delivery from factory	User's setting column	Setting
78	<b>CB8</b>	Action in AI1 disconnection	0		0: Upscale 1: Downscale  <b>Supplement</b> Effective for the T/C, RTD, mV and V inputs.
79	<b>CB9</b>	Adjustment of voltage output 1	15		2 to 22mA  <b>Supplement</b> Usually, the value set at delivery from the factory is applicable.
80	<b>CB0</b>	Adjustment of voltage output 2	15		2 to 22mA  <b>Supplement</b> Usually, the value set at delivery from the factory is applicable.
81	<b>CB1</b>	Extension setting 1	--		
82	<b>CB2</b>	Extension setting 2	0		0: Not provided. 1: Provided.  <b>Supplement</b> Used for maker service. Usually, kept at 0.
83	<b>CB3</b>	Extension setting 3	0		0: Not provided. 1: Provided.  <b>Supplement</b> Used for maker service. Usually, kept at 0.
84	<b>CB4</b>	Communication address	0		0 to 127  <b>Supplement</b> Communication is disabled when set to 0.
85	<b>CB5</b>	Transmission speed and code	0		0: 9600bps. Even parity, 1 stop bit 1: 9600bps. No parity, 2 stop bits 2: 4800bps. Even parity, 1 stop bit 3: 4800bps. No parity, 2 stop bits

Guide No.	Item code	Item	Set value at delivery from factory	User's setting column	Setting
86	<b>C86</b>	Unused.	--		
87	<b>C87</b>	Unused.	--		
88	<b>C88</b>	Unused.	--		
89	<b>C89</b>	Unused.	--		
90	<b>C90</b>	Special function 1	0		Used for maker service, and kept at 0.
91	<b>C91</b>	Special function 2	--		Used for maker service. Usually, not indicated.
92	<b>C92</b>	Special function 3	--		Used for maker service. Usually, not indicated.
93	<b>C93</b>	Special function 4	--		Used for maker service. Usually, not indicated.
94	<b>C94</b>	Unused.	--		
95	<b>C95</b>	Unused.	--		
96	<b>C96</b>	Hardware type 1	Used for maker service. Indication only, and unchangeable.		
97	<b>C97</b>	Hardware type 2			
98	<b>C98</b>	ROM ID			
99	<b>C99</b>	ROM item			
00	<b>C00</b>	ROM revision			

### 7-3 Detailed Description of SETUP Items

(Figure in brackets [ ] denotes the set value at delivery from the factory.)

#### C1: Key lock [ 0 ]

Key lock can be applied to all the keys, except for the UF1, UF2 and DISP keys mounted outside the door. When functions are assigned to the UF1 and UF2 keys, their call and setting change can be done even if their function source keys are key-locked. This function is effective when the operator is permitted to make minimum level operation. The lock itself can be called for setting change at any key lock level.

- 0: Key lock is not provided.
- 1: The indication and change only of a SETUP item (except for the key lock itself; also same in the following) are disabled.
- 2: The indication and change of PARA, PID and SETUP items are disabled.
- 3: The indication and change of SP, EV, PARA, PID and SETUP are disabled.
- 4: DISP, UF1 and UF2 only can be changed, and all others are disabled.

○ : Operation is enabled.  
 × : Operation is disabled.  
 \*1 : Key lock only can be operated.

< Key lock level table >

Key Assignment	SP/EV key	A/M key	R/L key	AT key	PARA key			DISP, UF1, UF2 key
					PARA setting	PID setting	SETUP setting	
0	○	○	○	○	○	○	○	○
1	○	○	○	○	○	○	× *1	○
2	○	○	○	○	×	×	× *1	○
3	×	○	○	○	×	×	× *1	○
4	×	×	×	×	×	×	× *1	○

**C2: Control action (master) [ 0 ]**

The direction of control action is set. In the internal cascade model, the direction of the action on the master side is set. The action can be inverted by an RSW.

0: Reverse action When the process quantity increases, the control output quantity decreases. Generally, this action is used for heating control or the like.

1: Direction action When the process quantity increases, the control output quantity also increases. Generally, this action is used for cooling control or the like.

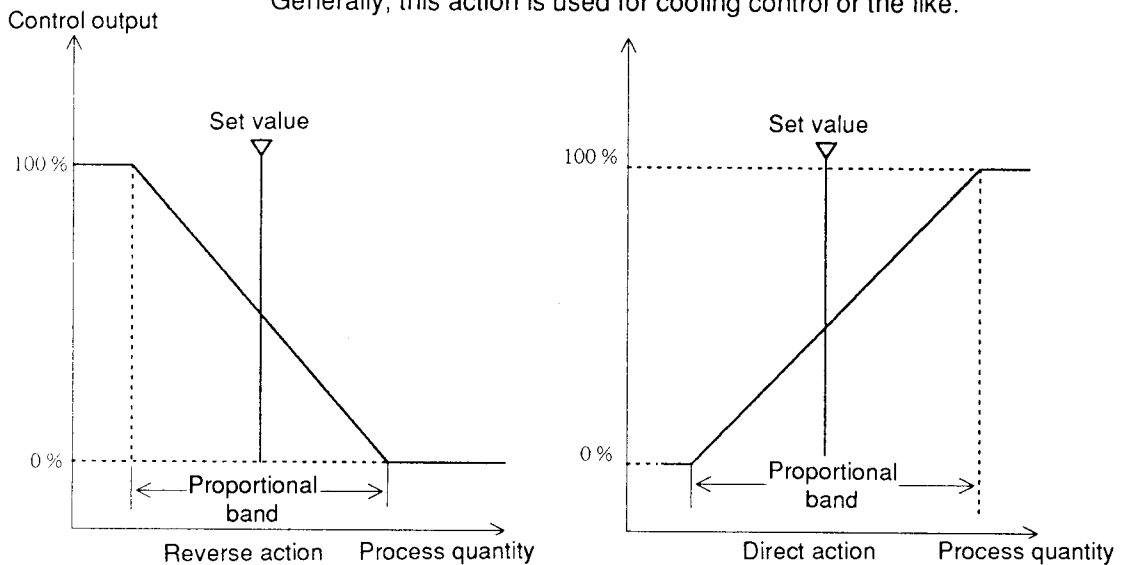

**C3: Control action (slave) [ 0 ]**

Internal cascade model only

The direction of a control action on the slave side of the internal cascade model is set.

The contents are the same as in C3, except for the inversion of the action by an RSW.

0: Reverse action

1: Direction action

**C4: Heat/cool output assignment [ 0 ]**

Heat/cool control model only

It is selected how the control output of the heat/cool control model is assigned.

For example, the set value at delivery from the factory is "0" in the AK model. When C2 is set to the reverse action, the heat side output is the current output, and the cool side control is the relay output. However, when this setup is changed into "1", the heat side control is the relay output, and the cool side control is the current output.

0: When C2 = 0 (reverse action), Heat = MV1, Cool = MV2

When C2 = 1 (direct action), Heat = MV2, Cool = MV1

1: When C2 = 0 (reverse action), Heat = MV2, Cool = MV1

When C2 = 1 (direct action), Heat = MV1, Cool = MV2

The PID operation method is such that two PID constants are assigned to the heat side and cool side, respectively; when the MV (control output) is 50% or more, the heat side PID constant is used for internal operation; when the MV is less than 50%, the cool side PID constant is used for internal operation. On/off control for P=0 cannot be done in the heat/cool model. The auto tuning cannot also be done. In the internal cascade model, the auto tuning can be done only on the master side, but it cannot be done in any other model.

PID constant group used

The heat/cool relation of the internal cascade model is as follows;

<u>Heat side</u>	<u>Cool side</u>	<u>PID group No.</u>	<u>Master side</u>	<u>PID group No.</u>
PID0	PID1	0	PID 0 to 5	0 to 5
PID2	PID3	1	Slave side	PID group
PID4	PID5	2	(heat side)	
PID6	PID7	3	PID6	--
			(cool side)	
			PID7	--

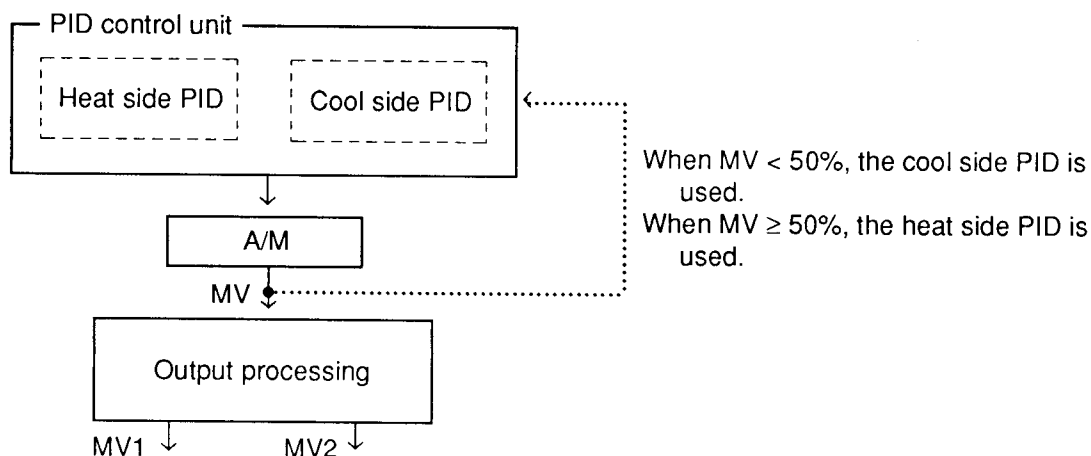

C5: AI1 (analog input 1) temperature unit [ 0 ]

When the input is T/C (thermocouple) or RTD (resistance thermometer bulb), its temperature unit is selected. The contents of the individual ranges are determined by C6 (AI1 input range type) and the PV range number table given on page 1-7 and 1-8.

- 0: °C (Centigrade)
- 1: °F (Fahrenheit)

C6: AI1 input range type [ 0 ]

AI1 is handled as a PV input in the standard model, remote SP model and internal cascade model. The instrument can cope with any input and range by setting the PV range number given on page 1-7 and 1-8. However, the terminal numbers of the input connection change, depending upon the thermocouple, resistance thermometer bulb, voltage input and current input, the wiring should be changed, referring to the terminal layout given on page 3-5.

If the actual input is smaller or larger than the set input range, it is indicated down to -10% FS or up to +110% FS. Any input out of this indication range is processed as an input overrange.

The SP limit is not interlocked with the contents of a set range, but is independent. Therefore, there is such a case that setting beyond the range can be done. When the range is changed, be sure to reset the SP limit values of C17 and 18.

C7: AI1 linear input decimal point position [Undefined]

Only when the voltage, current input range numbers are set in C6.

In the case of the linear input (voltage, current input), a decimal point position is set for scaling.

- 0: x x x x x
- 1: x x x x . x
- 2: x x x . x x
- 3: x x . x x x
- 4: x . x x x x

C8: AI1 linear input low limit [Undefined]

Only when the voltage, current input range numbers are set in C6.

-19999 to 26000U

In the case of the linear input (voltage, current input), the low limit value is set for scaling.

For example, when the 4 to 20mA input (Range No. 64) is selected, and the contents of the output side of 4mA are 0.000, set "3" in C7 to determine the decimal point position, and at the same time, set and input 0.000 with  keys.

C9: AI1 linear input high limit [Undefined]

Only when the voltage, current input range numbers are set in C6.

In the case of the linear input (voltage, current input), the high limit is set for scaling.

For example, when the contents are the same as the example of C8, and 20mA is 14.000, set and input 14.000 with  keys.

The numerics of C8 and C9 are free in magnitude relation, so C8 > C9 is permitted for setting. In the above example, 14.000 and 0.000 can be set for the 4mA input and 20mA input, respectively.

C10: AI1 linear input square root operation and dropout [ 0.0 ]

Only when the voltage, current input range numbers are set in C6.

In the case of the linear input (voltage, current input), a square root operation can be done. At the same time, a dropout value in the square root operation is set.

0.0: Square root operation is not provided.

0.1 to 10.0% FS: Square root operation is provided. At the same time, a dropout value (0.1 to 10.0%) is set.

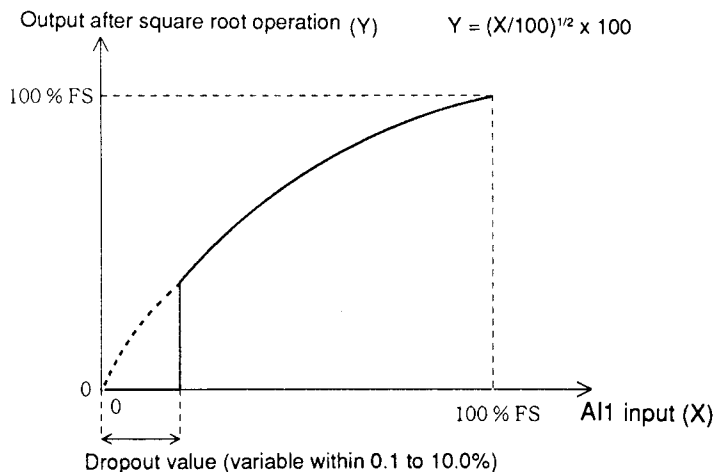

Scaling processing is executed after the square root operation. However, when the square root operation is provided, a dropout value cannot be set to 0.0%

C11: AI2 (analog input 2) input type [ 0 ] Remote SP model, and internal cascade model only

AI2 is set in the remote SP model and internal cascade model.

In the remote SP model, AI2 is processed as a remote set point (RSP). In the internal cascade model, it is processed as the second PV input (PV2).

The following two input types only are available. When the input type is changed, the terminal numbers of the input connection are also changed. Refer to the terminal layout given on page 3-5.

- 0: 4 to 20mA
- 1: 1 to 5V

C12: AI2 decimal point position [ 0 ] Internal cascade model only

- 0: x x x x x
- 1: x x x x . x
- 2: x x x . x x
- 3: x x . x x x
- 4: x . x x x x

In the case of the remote SP model, the decimal point position of AI1 is used as it is as that of AI2.

C13: AI2 input low limit [ 0 ] Remote SP model, and internal cascade model only

-19999 to 26000U

C14: AI2 input high limit [ 0 ] Remote SP model, and internal cascade model only

-19999 to 26000U

The numerics of C13 and C14 are free in magnitude relation.







C15: AI2 square root operation and dropout [ 0.0 ] Remote SP model, and internal cascade model only

0.0: Square root operation is not provided.

0.1 to 10.0% FS: Square root operation is provided. At the same time, a dropout value is set.

C16: LSP setting system [ 0 ]

There are an LSP (local SP) and an RSP (remote SP) as SPs in the remote SP model and internal cascade model. It is set in this setup item whether only one LSP or more than one LSP (8 LSPs) are to be used. When the set values are decided by the control object, more than one LSP can be conveniently used without a setting change trouble. The PID number can be changed by key operation, except for the case where "3" is set in this setup, thus permitting all assignments using RSWs as well.

- 0: Only one LSP is used. The SP value can be changed usually. After changing the numeric with  key, press the  key, then the LSP value will be changed for the first time.
- 1: One LSP is used as in "0" above, but the direct change system is used to change the LSP value. In the direct change system, the LSP value is changed directly and internally at the same time as the numeric is changed with  keys. However, if the  key is pressed as it is without pressing the  key, the LSP value is reset to the value before pressing  keys. Therefore, be sure to press the  key finally to settle the LSP value.

The LSP direct change function has priority over the LSP ramp function, and the SP being indicated is taken in as an internal LSP as it is. This direct change system is effective to check a PV changing status while changing an LSP little by little, or to prevent an LSP from being changed suddenly.

- 2: 8 LSPs are used. The PID group number used can be changed by operating the SP/EV key. When the model is not provided with an RSW option, or it is provided with an RSW option, but the LSP selection is not assigned to any RSW, all 8 LSPs can be changed from the console. When the LSP selection is assigned to an RSW, the LSP group cannot be changed from the console, since the RSW has priority. However, the LSP value can be changed.
- 3: 8 LSPs are used. This setting permits only the selection of an LSP group to be executed from the console or by an RSW, but inhibits the change of the LSP value and PID group. Therefore, this is used when the LSP value or PID group is not desired to be changed carelessly.

C17: Low limit of SP limit [ -19999 ]

This setup decides the low limit values of the LSP and RSP. Use it when the SP value is not desired to be lower than this value. This function is effective for both LSP and RSP.

**Since this value is kept unchanged when the range is changed, be sure to set a necessary value to assure safety.**

C18: High limit of SP limit [ 26000 ]

The high limit value of the LSP and RSP is decided. Use this setup item when the SP value is not desired to be higher than this value. This function is effective for both LSP and RSP.

**Even when the range is changed, this value is kept unchanged. For example, when the high limit of the range is 1200.0°C, 2600.0°C can be used with the set value at delivery from the factory kept as it is. Be sure to set a necessary value for this setup to assure safety.**

C19: At AI overrange, contents selection of control output (MV) [ 0 ]

The control output quantity in the case where the AI1 or AI2 input causes an overrange (110% FS min) can be set in advance to the set value in C20. This setup is used to make this processing selectively when either input causes an overrange.

Particularly, when a burnout upscale is set in the T/C or RTD input range, or the mV input range is applied, an overrange occurs if the input is disconnected. This setup is used when the control output quantity is to be decided in advance so as to be set to the safety side in such cases.

- 0: Not provided. The control output is continued, and its quantity is determined by the input indication value and internal operation (PID, etc.).
- 1: When AI1 causes an overrange, the quantity set in C20 is output.
- 2: When AI2 causes an overrange, the quantity set in C20 is output.
- 3: When either or both of AI1 and AI2 cause an overrange, the quantity set in C20 is output.

**C20: At AI overrange, setting of control output quantity [ 0 ]**

When the input selected in "1" to "3" of C19 causes an overrange, the control output quantity set in this setup is output.

-10 to 110%

In the heat/cool output model, the same value is output as MV1 and MV2.

**C21: Manual change mode [ 0 ]**

When the manual operation is to be done by the AUTO/MAN key on the console, or the AUTO/MANUAL selection of the Function No. 2 assigned to an RSW, the control output method is selected by this setup. Even when either case is used, the following manual output can be changed from the console.

0: Bumpless (the present output is held)

1: Preset (the set value in C22 is output)

When MANUAL is reset to AUTO, the control operation starts with the present output value.

Even when the fixed-value output of Function No. 17 to 19 is assigned to RSW, the MANUAL change has priority over these functions. It also has priority over the READY mode output.

**C22: Preset MANUAL value [ 0 ]**

The output value in the case where "1" (preset) is selected in C21 is set in this setup. If power failure occurs on the course of the MANUAL output change from the console, the set value in C22 is output after power recovery irrespective of option in C21.

-10 to 110%

**C23: Fixed value output 1 by RSW [ 0 ]**

Only when RSW (OP) is provided

The fixed value output 1 in the case where Function No. 17 is assigned to an RSW is set in this setup item.

-10 to 110%

**C24: Fixed value output 2 by RSW [ 0 ]**

Only when RSW (OP) is provided

The fixed value output 2 in the case where Function No. 18 is assigned to an RSW is set in this setup item.

-10 to 110%

**C25: Fixed value output 3 by RSW [ 0 ]**

Only when RSW (OP) is provided

The fixed value output 3 in the case where Function No. 19 is assigned to an RSW is set in this setup item.

-10 to 110%

**C26: Setting of control output quantity in READY mode [ 0 ]**

The control output quantity in the READY mode is set in this setup item. In the heat/cool model, this functions as the control output on the heat side in the READY mode.

-10 to 110%

C27: Setting of cool side control output quantity in READY mode [ 0 ]

Heat/cool model only

The control output quantity on the cool side in the READY mode of the heat/cool model is set in this setup.

–10 to 110%

C28: Event in READY mode [ 0 ]

The contents of an event action in the READY mode are selected in this setup. The non-action of an event can be selected only in this setup. The event action is enabled in any other case such as during the MANUAL operation or fixed value output.

0: Event action is enabled even in the READY mode.

1: Event action is disabled in the READY mode.

C29: Setting of internal RSP 0% [ 0 ]

Internal cascade model only

In the internal cascade model, the scaling 0% value of I-RSP is set in this setup. The slave side RSP is connected with the master side control output internally.

–19999 to 26000U

The decimal point position is determined by the setting of AI (analog input) corresponding to the slave side input. For example, when –100 is set in the case of the decimal point position x x x x . x, the 0% value of the actual RSP is –10.0.

C30: Setting of internal RSP 100% [ 10000 ]

Internal cascade model only

In the internal cascade model, the scaling 100% value of I-RSP is set in this setup.

–19999 to 26000U

The decimal point position is determined by the setting of AI (analog input) corresponding to the slave side input. For example, when 12000 is set in the case of the decimal point position x x x x . x, the 100% value of the actual RSP is 1200.0.

C31: AI1 and AI2 exchange [ 0 ]

Internal cascade model only

It is selected in this setup whether each analog input of AI1 or AI2 is to be assigned as a master control PV or as a slave control PV in the internal cascade model.

0: Not exchanged (AI1 = Master control PV, AI2 = Slave control PV)

1: Exchanged (AI1 = Slave control PV, AI2 = Master control PV)

Particularly, since AI1 is of a full multi input type, a temperature converter can be omitted by selecting "1" (exchanged) in such an application that the slave control PV input is T/C or RTD, and the master control PV input is 4 to 20mA or 1 to 5V.

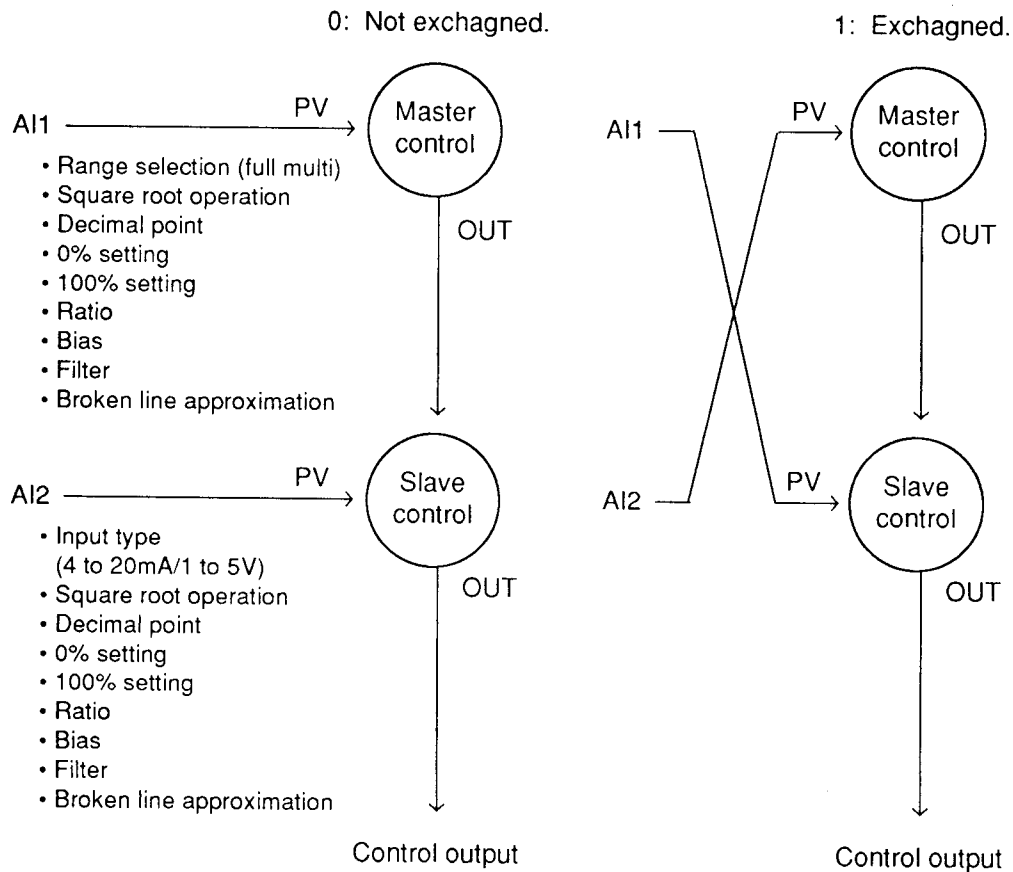

Since this exchange is executed internally, the connection of the input terminals need not be done.

C32: Type of auxiliary output 1 (AUX1) [ 0 ]

Only when the auxiliary output 1 (OP) is provided

The output contents of the auxiliary output (4 to 20mA) 1 are selected in this setup.

■ Standard model and external cascade model

- 0: PV
- 1: SP
- 2: DEV
- 3: MV
- 4: RSP
- 5: Motor opening (MFB)

■ Internal cascade model

- 0: PV of master control (PV1)
- 1: SP " (SP1)
- 2: DEV " (DEV1)
- 3: MV " (MV1)
- 4: ...
- 5: MFB
- 6: PV of slave control (PV2)
- 7: SP " (SP2)
- 8: DEV " (DEV2)
- 9: MV " (MV2)
- 10: Internal RSP (I-RSP)

The individual output values are positioned as shown below.

■ Standard model and remote SP model

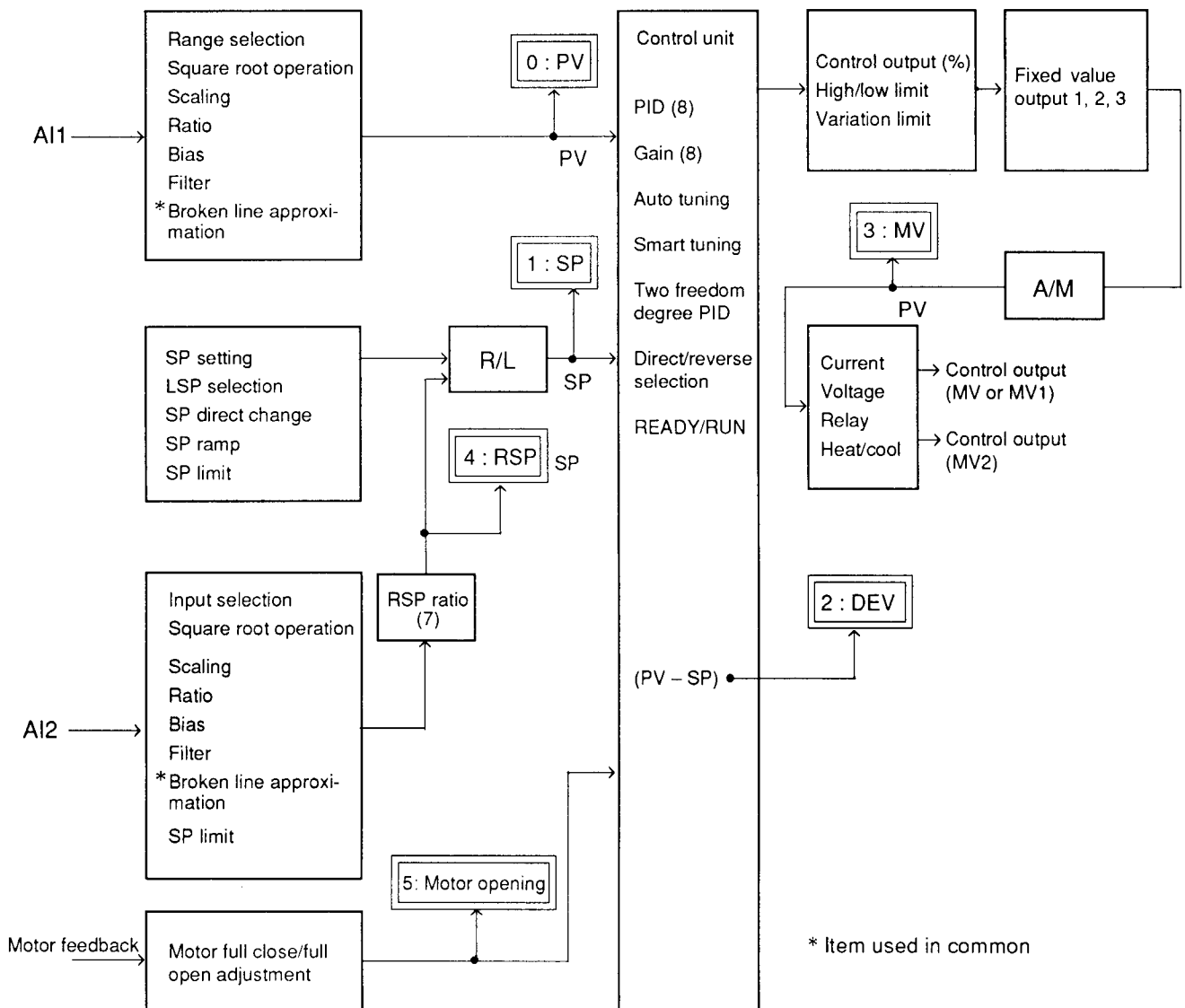

Internal cascade model

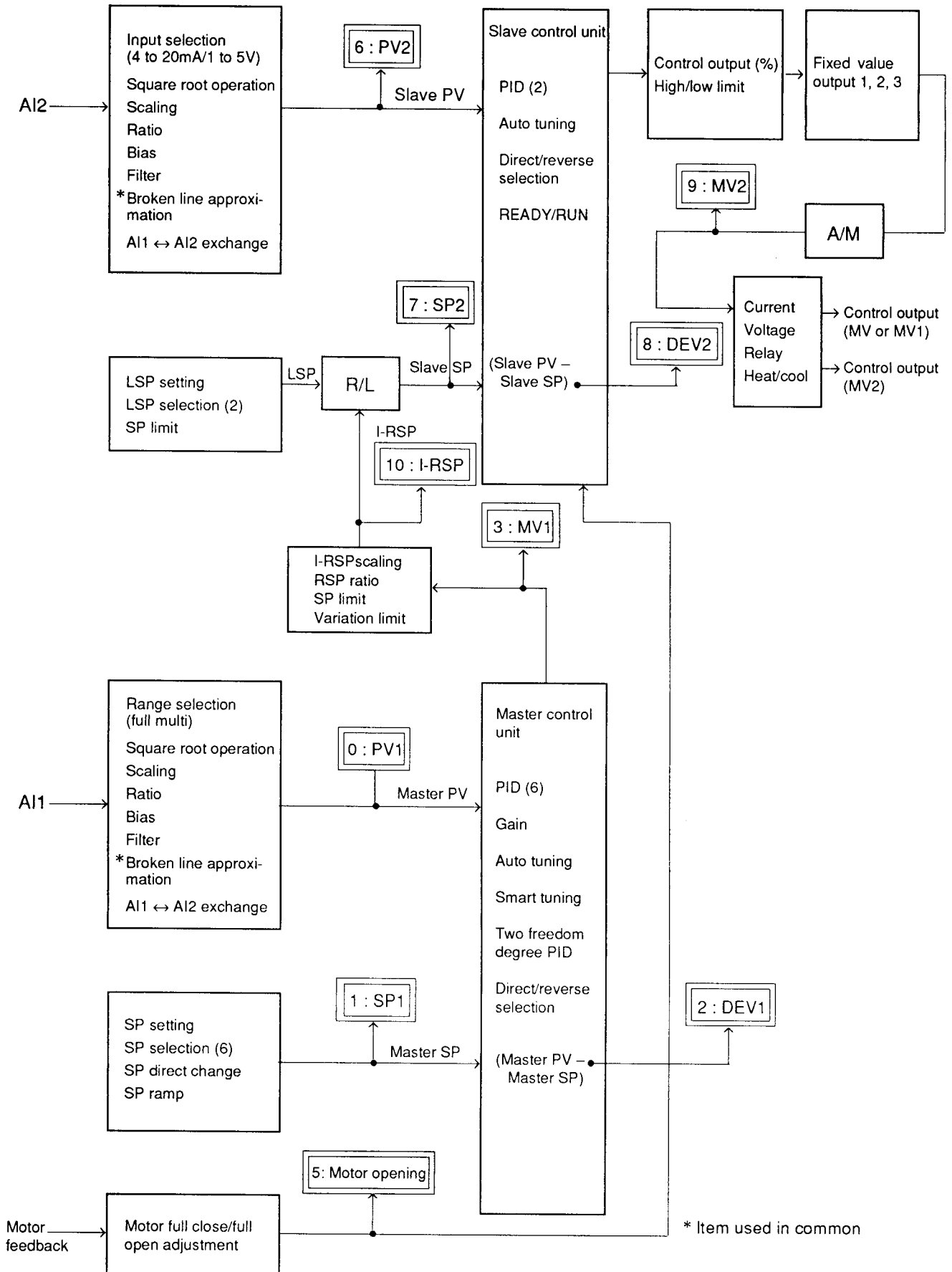

C33: Auxiliary output 1      4mA setting [0% FS]      Only when the auxiliary output 1 (OP) is provided

C34: Auxiliary output 1      20mA setting [100% FS]      Only when the auxiliary output 1 (OP) is provided

Scaling for the auxiliary output. This scaling can be set optionally within the following ranges. Expansion, shrinkage and reverse scaling can also be executed. The numerics of C33 and C34 are free in magnitude relation.

-19999 to 26000U

-1999.9 to 2600.0U (MV, motor opening)

Example 1: When the 0.0 to 1000.0°C of PV (K: 0.0 to 1200.0°C) are to be output as 4 to 20mA, set the numerics in C33 and C34 as follows;

C33 → 0

C34 → 10000

Example 2: When the MV (0 to 100%) is to be output reversely with 100% as 4mA, and 0% as 20mA, set the numerics in C33 and C34 as follows;

C33 → 100.0

C34 → 0.0

Example 3: When the MV is to be output with 100% as 12mA and 0% as 20mA in Example 2, set the following values in C33 and C34 since 200% is obtained if the MV at 4mA is found imaginarily.

C33 → 200.0

C34 → 0.0

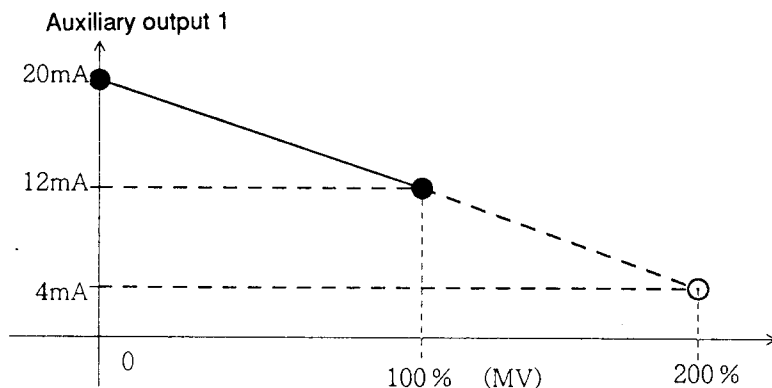

C35: Auxiliary output 1      Output in READY mode [ 0 ]      Only when the auxiliary output 1 (OP) is provided

The output system in the READY mode is selected in this setup.

0: Bumpless (The present output is held.)

1: Preset (The set value in C36 is output.)

C36: Auxiliary output 1      Setting of preset output quantity in READY mode [ 0 ]      Only when the auxiliary output 1 (OP) is provided

The output quantity in the case where the READY mode is set with C35 = 1 is set in industrial unit in this setup. The actual current output value is related with the settings of C33 and C34.

-19999 to 26000U

-1999.9 to 2600.0U (MV, motor opening)

For example, when 12mA is to be output in the READY mode in Example 1 of C34, set 5000 in this setup.

C37: Type of auxiliary output 2 (AUX2) [ 0 ]	Only when the auxiliary output 2 (OP) is provided
C38: Auxiliary output 2 (AUX2) 4mA setting [0% FS]	"
C39: Auxiliary output 2 (AUX2) 20mA setting [100% FS]	"
C40: Auxiliary output 2 (AUX2) Output in READY mode [ 0 ]	"
C41: Auxiliary output 2 (AUX2) Setting of preset output quantity in READY mode [ 0 ]	"

The contents of these setup items are equivalent to C32 to C36. The auxiliary output 1 and auxiliary output 2 are isolated from each other, so double setting can also be done.

C42: RSW1 assignment [ 0 ]	Only when the RSW (OP1) is provided
C43: RSW2 assignment [ 0 ]	"
C44: RSW3 assignment [ 0 ]	"
C45: RSW4 assignment [ 0 ]	"
C46: RSW5 assignment [ 0 ]	Only when the RSW (OP2) is provided
C47: RSW6 assignment [ 0 ]	"
C48: RSW7 assignment [ 0 ]	"
C49: RSW8 assignment [ 0 ]	"
C50: RSW9 assignment [ 0 ]	"
C51: RSW10 assignment [ 0 ]	"
C52: RSW11 assignment [ 0 ]	"
C53: RSW12 assignment [ 0 ]	"

Various actions can be selected and set by RSWs. The hold time of 200msec min is required to detect RSW ON or OFF.

The hold time of 1sec min is required to read the selection of LSP, PID, and AI2 Ratio No. This is intended to prevent malfunction from being caused by chattering.

The auto tuning starts and stops by detecting a change from OFF to ON. In this case, the hold time of 500msec min is required to detect ON. When restarting the auto tuning, turn OFF the RSW once.

When RUN/READY, AUTO/MANUAL, and REMOTE/LOCAL selection, LSP number selection and PID number selection are assigned to RSWs, these functions cannot be activated from the console.

If the same function, which causes a trouble when used doubly, is assigned to more than one RSW, the RSW having a younger number becomes effective, and the others have NOP function. A weight function such as 2° can be used doubly. However, when there is not a function (number) relevant to the sum of its weight numbers, this is equivalent to the selection of "0". The NOP function is totally effective when assigned to more than one RSW.

(Continuation of RSW assignment)

Each function of the RSW assignment is described below. In this description, [ / ] denotes (when the external contacts are closed) / (when the external contacts are open), and [ - ] indicates to have no effect on the operation.

0: NOP/-

NOP has no effect on the actual control or action, but it can be read on the host side only by the communication. Therefore, it can be used to obtain the contact input information by the host computer, or the like without affecting the control or action.

1: READY/RUN

The same contents as the RUN/READY selection function of the first PARA item can be executed. When this function is assigned, the RUN/READY selection operation cannot be done from the console.

2: MANUAL/AUTO

The same operations as the  key can be done. When this function is assigned, the AUTO/MAN key is ineffective.

3: REMOTE/LOCAL

The same operation as the  key can be done. When this function is assigned, the REMOTE/LOCAL key is ineffective.

4: AUTO TUNING Start/AUTO TUNING Stop

The AUTO TUNING is started by detecting an off to on (500msec min) change of an RSW. During the AUTO TUNING, the RSW must be kept on continuously. To interrupt the AUTO TUNING, turn off (500msec min) the RSW.

5: Inversion of control action/as set in C2

This setting is used when the heat source (heating source, cooling source) is changed over according to the season (summer, winter) in the temperature control of an air conditioner, or the like. In the internal cascade model, the slave side control action is not inverted, but the master side control action is inverted.

6: Undefined -/-

7: Undefined -/-

8: Undefined -/-

9: Undefined -/-

This assignment has no effect on any control or action.

10: LSP number selection  $2^0$  (+1)/LSP number selection 0

11: "  $2^1$  (+2)/ " 0

12: "  $2^2$  (+4)/ " 0

When C16 = 2 or 3, more than one LSP can be selected by RSWs.

(When C16 = 0 or 1, the assignment of this function is ignored.)

An LSP is selected by the sum of weight numbers of an assigned RSW. When the same weight is assigned to another RSW, the sum of the weight numbers can also be obtained.

The sum 0 to 7 of weight numbers corresponds to LSP No. 0 to LSP No. 7, respectively.

If the sum of weight numbers exceeds 8, LSP No. 0 is selected.

When each set value of an LSP is changed, only that, which can be used by the assigned RSW, is indicated.

Example 1: When two LSP Nos. 0 and 1 are selected;

RSW to which 10 (+1/0) is assigned	X	O	(X: Contact off, O: Contact on)	
Sum of weight numbers	0	1		
LSP No.	0	1		

Example 2: When eight LSP Nos. 0 to 7 are selected;

RSW to which 10 (+1/0) is assigned	X	O	X	O	X	O	X	O
RSW to which 11 (+2/0) is assigned	X	X	O	O	X	X	O	O
RSW to which 12 (+4/0) is assigned	X	X	X	X	O	O	O	O
Sum of weight numbers	0	1	2	3	4	5	6	7
LSP No.	0	1	2	3	4	5	6	7

The same result can also be obtained by making assignment doubly as shown below. In this case, however, the number of RSWs used must be many.

RSW to which 10 (+1/0) is assigned	X	O	O	O	O	O	O	O
"	X	X	O	O	O	O	O	O
"	X	X	X	O	O	O	O	O
"	X	X	X	X	O	O	O	O
"	X	X	X	X	X	O	O	O
"	X	X	X	X	X	X	O	O
"	X	X	X	X	X	X	X	O
Sum of weight numbers	0	1	2	3	4	5	6	7
LSP No.	0	1	2	3	4	5	6	7

- 13: PID number selection +1/PID number selection 0
- 14: " +2/ " 0
- 15: " +4/ " 0

(Continuation of RSW assignment)

The number of built-in PID groups is eight (No. 0 to No. 7). PID Group No. 0 cannot be selected by any RSW. When all the assigned RSWs are off, the PID number set by the  $\text{SP/EV}$  key (interlocked with SP number) is selected.

The selection by an RSW has priority over the PID number interlocking with SP number.

The PID is selected by the sum of the weight numbers of the assigned RSW.

When the same weight is assigned to another RSW, the sum of its weight numbers can also be obtained. If the sum of the weight number exceeds 8, the PID number (interlocking with SP number) set by the  $\text{SP/EV}$  key is selected.

Example 1: When PID1, which is being used for SP1 by interlocking, is changed over to PID2 by the RSW.

RSW to which 14 (+2/0) is assigned	X	O	(X: Contact off, O: Contact on)
Sum of weight numbers	0	2	
PID No.	1	2	

↑  
(Interlocking with SP)

Example 2: When PID1, which is being used for SP1 by interlocking, is changed over to PID2 to 7 by the RSW according to the condition.

RSW to which 13 (+1/0) is assigned	X	O	X	O	X	O	X	O
RSW to which 14 (+2/0) is assigned	X	X	O	O	X	X	O	O
RSW to which 15 (+4/0) is assigned	X	X	X	X	O	O	O	O
Sum of weight numbers	0	1	2	3	4	5	6	7
LSP No.	0	1	2	3	4	5	6	7

↑ (Interlocking with SP)

↑ PID No. 1 selected by RSW. This is not changed since it is the same as the SP interlocking number.

To check what PID group number is selected by the RSW, press the  $\text{PARA}$  key in the RUN mode, and press the  $\text{ENT}$  key with [PID] indication. The PID group being then used is indicated at first.

16: S-LSP7/S-LSP6

It is determined which slave side LSP is to be selected in the internal cascade model. This selection can be done only by the RSW, and it is effective only by this assignment.

17: Fixed value output 1 (set value in C23) / -

18: Fixed value output 2 (set value in C24) / -

19: Fixed value output 3 (set value in C25) / -

(Continuation of RSW assignment)

The fixed values set in C23 to C25 in advance can be output. The priority relation between the READY/RUN and MANUAL/AUTO is as follows;

The fixed value output has priority over the PID control or the READY mode output. Among the fixed value outputs, the fixed value output 1 has the highest priority. In any case, the manual operation has the highest priority.

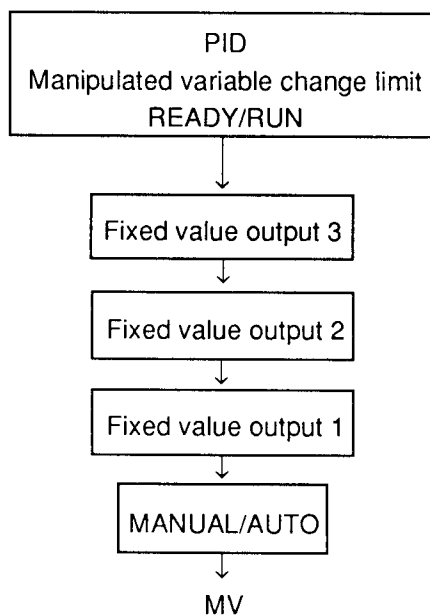

Even when the fixed value is output, the event function is effective. When the fixed value selection is all off and the RUN and AUTO modes are selected, the result of PID operation is output in the bumpless mode.

The manipulated variable change limit is not activated at each changeover time.

- 20: LSP shift number  $2^0 (+1) / 0$
- 21: LSP shift number  $2^1 (+2) / 0$
- 22: LSP shift number  $2^2 (+4) / 0$
- 23: LSP shift number  $2^3 (+8) / 0$
- 24: LSP shift number  $2^4 (+16) / 0$
- 25: LSP shift number  $2^5 (+32) / 0$
- 26: LSP shift number  $2^6 (+64) / 0$
- 27: LSP shift number  $2^7 (+128) / 0$
- 28: LSP shift number  $2^8 (+256) / 0$
- 29: LSP shift number  $2^9 (+512) / 0$

The LSP shift of 20 to 29 is assigned to an RSW, and the sum of the individual weight numbers (20 to 29) caused by the on/off of the RSW corresponds to the LSP shift number. The product of this LSP shift number and the LSP shift width set in C54 becomes the LSP shift quantity, and this is added to the LSP being executed (subtracted, depending upon setting in C54). The base LSP may be set from the console or may be selected by an RSW, but it cannot be added to the RSP. The SR ramp function also has effect on the LSP shift.

(Continuation of RSW assignment)

The LSP shift quantity is not stored in the memory.

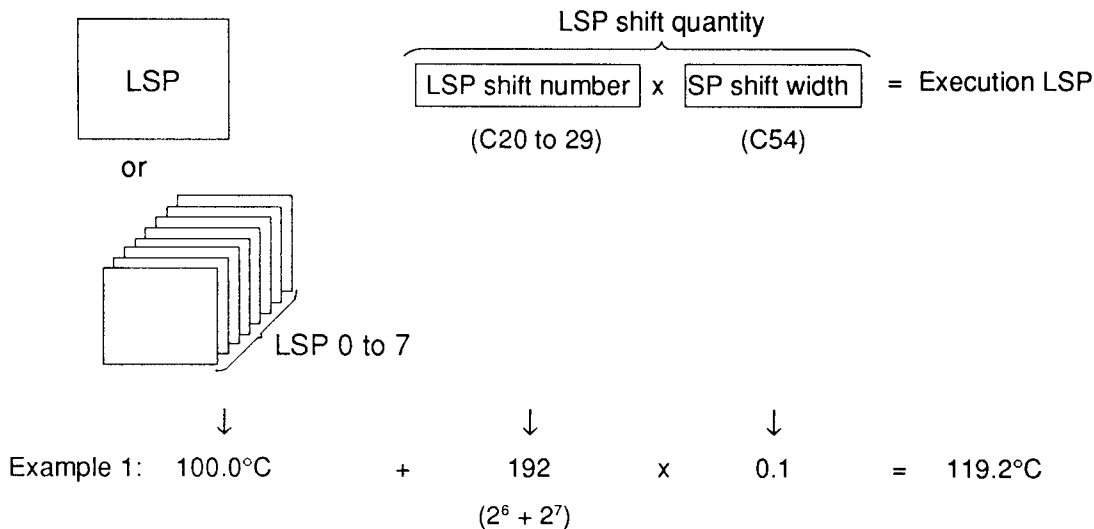

The same result can be obtained by using the same shift number doubly as shown below.

$$\text{Example 2: } 100.0^{\circ}\text{C} + 192 \times 0.1 = 119.2^{\circ}\text{C}$$

$$(2^6 + 2^6 + 2^6)$$

- 30: RSP ratio number selection +1/0
- 31: RSP ratio number selection +2/0
- 32: RSP ratio number selection +4/0

The RSP ratio is a function peculiar to the remote SP model and internal cascade model, and it is also used for gain setting in these models. Either ratio setting or gain setting is selected by Guide No. 49 of the PARA setting. Further, the seven ratio values of ratio 1 to ratio 7 are set within the range of 0.001 to 30.000 by Guide Nos. 50 to 56 of the PARA setting.

The RSP ratio is selected by the sum of the weight numbers of the assigned RSW. When the same weight is assigned to another RSW, the sum of its weight numbers can also be obtained.

The sum 1 to 7 of the weight numbers correspond to Ratio Nos. 1 to 7, respectively. When none is selected, the sum of the weight numbers becomes 0, and the RSP ratio selection function is ineffective. If the sum of the weight numbers exceeds 8 on the contrary, none is identified to be selected, and the RSP ratio selection function is also ineffective.

The ratio can be set to AI2 evenly by Guide No. 6 (AI2 ratio) of the PARA setting. When the RSP ratio number is selected with respect to this AI2 ratio, the RSP ratio is selected in priority as shown in the figure below. Unless the RSP ratio number is selected (when 0), the AI2 ratio is selected.

(Continuation of RSW assignment)

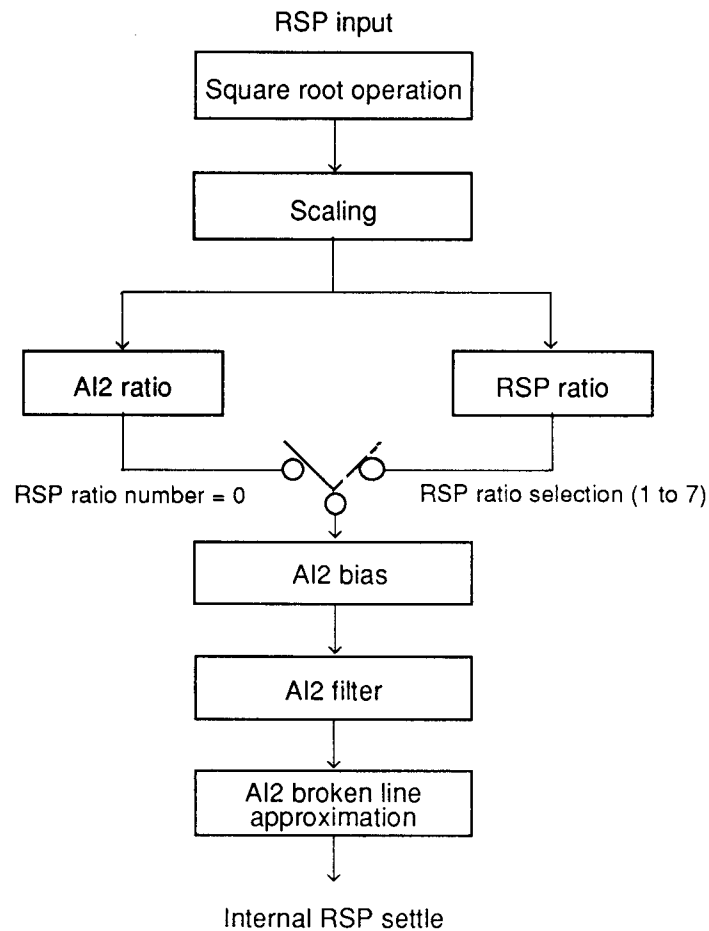

33: Computer backup system 1/MV signal output from host

34: Computer backup system 2/MV signal output from host

The computer backup is a function peculiar to the remote SP model. Usually, the control output of the host computer is output as it is. If the host computer is down, the control is maintained by RSW changeover. At this time, the output is of a bumpless type (only in system 1). Both computer backup systems 1 and 2 cannot be assigned simultaneously.

Computer backup system 1:

The present PV value is used as an LSP to continue the control. However, the PV written in the LSP is restricted by the SP limit value. The PV ramp function is activated as usual. The output type is bumpless.

Computer backup system 2:

The LSP set from the console or that selected by an RSW is used as an SP to continue the control. The output type is not bumpless. In particular, the deviation output of  $|SP - PV|$  is bumped.

Both computer backup systems 1 and 2 do not function, unless "1" (C/B) is set in C75. The REMOTE/LOCAL selection function is ineffective when the computer backup is assigned.

(Continuation of RSW assignment)

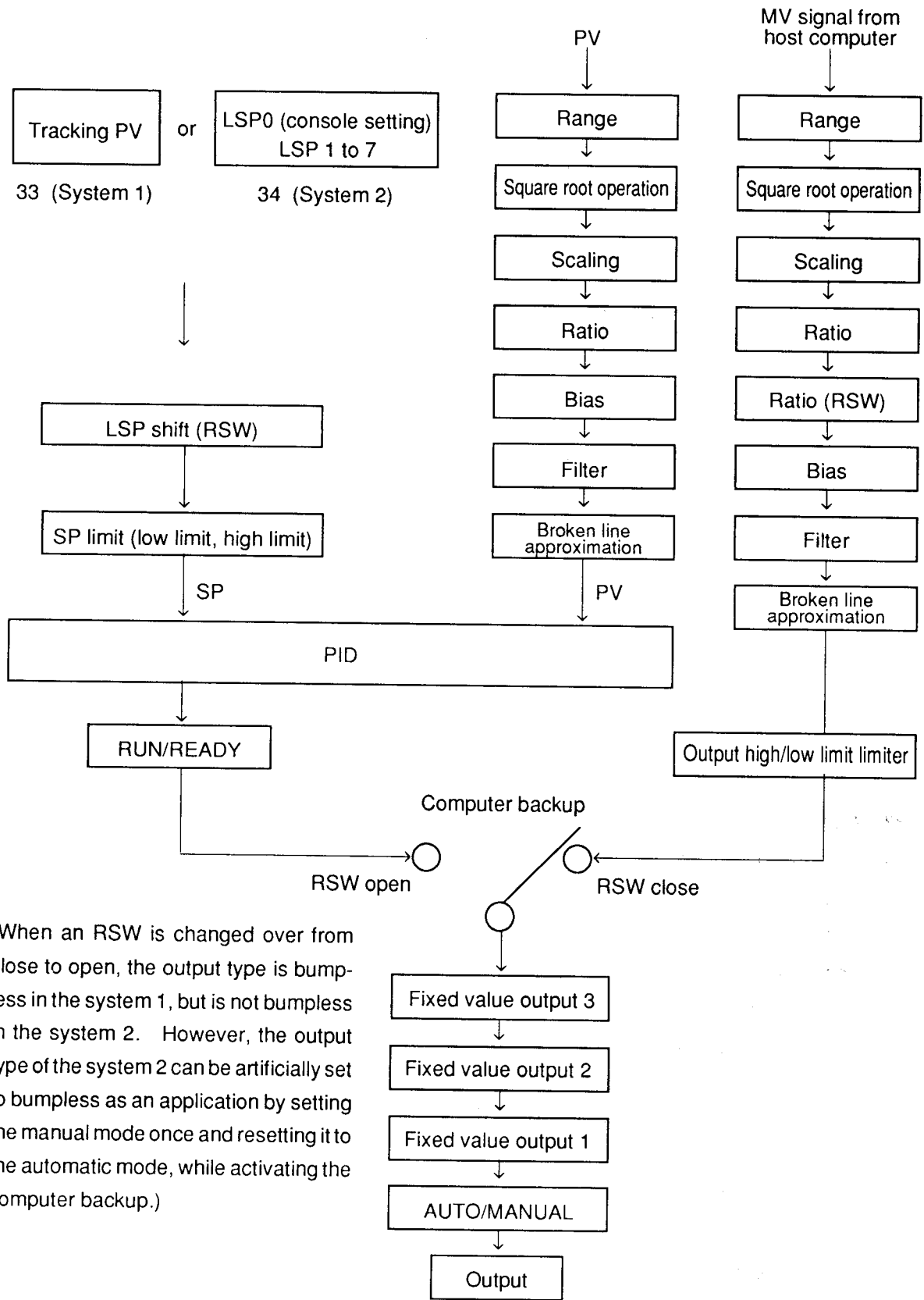

(When an RSW is changed over from close to open, the output type is bumpless in the system 1, but is not bumpless in the system 2. However, the output type of the system 2 can be artificially set to bumpless as an application by setting the manual mode once and resetting it to the automatic mode, while activating the computer backup.)

C54: LSP shift width by RSW [ 0 ]

Only when RSW (OP) is provided

The shift width is set in this setup when the LSP shift is assigned to an RSW in C42 to C53.

-19999 to 10000U

C55: UF1 key basic register [ 0 ]

The contents assigned can be called and changed even in key lock status. Double assignment can be done to the UF1 key and UF2 key.

- 0: Not registered
- 1: Same as the AUTO/MAN key
- 2: Same as the REM/LOC key
- 3: Same as the AT key
- 4: Same as the RUN/READY function
- 5: Selection from among SP, EV, PARA, PID, and SETUP items

In assignment of "1" to "4", only one function can be registered in the UF1 key. The contents of the "4" assignment are the same as "5" is selected and C01 of the PARA setting is selected.

When "5" is assigned, up to four items of C56 to C59 can be registered.

C56: UF1 assigned content 1 [ 0 ]

C57: UF1 assigned content 2 [ 0 ]

C58: UF1 assigned content 3 [ 0 ]

C59: UF1 assigned content 4 [ 0 ]

When C55 = 5, Guide No. of each setup to be registered plus the following radix are to be set in this setup.

If an in-existent item number is set, this is ineffective, and non operation is done. For example, "0" set at delivery from the factory is an in-existent number, so it is ineffective.

SP radix; + 4000, EV radix; + 4500, PID radix; + 5000, PARA radix; + 5500,  
SETUP radix; + 6000

Example: When LSP0 is registered in FU1;

4002 (SP radix + LSP0 value Guide No. = 4000 + 2 = 4002) is set in C56 with C55 = 5.

C60: UF2 key basic register [ 0 ]

The contents assigned can be called and changed even in key lock status. Double assignment can be done to the UF2 key and UF1 key. The assigning method and contents of the UF2 key are the same as in the UF1 key, but up to 8 items can be assigned to the UF2 key.

- 0: Ineffective (does not function)
- 1: Same as the AUTO/MAN key
- 2: Same as the REM/LOC key
- 3: Same as the AT key

- 4: Same as the RUN/READY function
- 5: Selection from among SP, EV, PARA, PID, and SETUP items

In assignment of "1" to "4", only one function can be registered in the UF1 key. The contents of the "4" assignment are the same as "5" is selected and (RUN/READY selection) of the PARA setting is selected. When "5" is assigned, up to four items of C61 to C68 can be registered.

- C61: UF2 assigned content 1 [ 0 ]
- C62: UF2 assigned content 2 [ 0 ]
- C63: UF2 assigned content 3 [ 0 ]
- C64: UF2 assigned content 4 [ 0 ]
- C65: UF2 assigned content 5 [ 0 ]
- C66: UF2 assigned content 6 [ 0 ]
- C67: UF2 assigned content 7 [ 0 ]
- C68: UF2 assigned content 8 [ 0 ]

When C60 = 5, Guide No. of each setup to be registered plus the following radix are to be set in this setup. If an inexistent item number is set, this is ineffective, and non operation is done.

SP radix; + 4000, EV radix; + 4500, PID radix; + 5000, PARA radix; + 5500,  
SETUP radix; + 6000

Example: When the EV1 set value is registered in UF2;  
4501 (EV radix + EV1 set value Guide No. = 4500 + 1 = 4501) is set in C61 with C60 = 5.

- C69: Basic register of UF LED indication [ 0 ]

It is selected in this setup when the UF LED (one) will light.

- 0: Not registered (does not light)
- 1: Lights when there is an item which is registered in the UF1 or UF2 key.
- 2: EV (lights when an event is on)
- 3: RSW (lights when RSW is on)

When "2" or "3" is selected, its contents are to be registered in C70.

- C70: Assigned contents of UF LED indication [ 0 ]

When "2" or "3" is selected in C69, its contents are registered in C70. When C69 = 2, the EV number (1 to 8) to be lighted is registered. When C69 = 3, the RSW number (1 to 12) to be lighted is registered. Although the settable range is within 0 to 255, the setting of any other than the above-mentioned numerics is ineffective, and it does not cause the UF LED to be lighted.

**C71: Selection of indication contents of bar graph indicator [ 0 ]**

The indication contents of the 12-segment bar graph indicator can be selected from among the following items in this setup.

**0: Output monitor (OUT monitor)**

The bar graph content LED (OUT LED) lights. Among the 12 segments, one each end segment of the left and right is not used, but the remaining 10 segments are lighted by the output (%) as shown below.

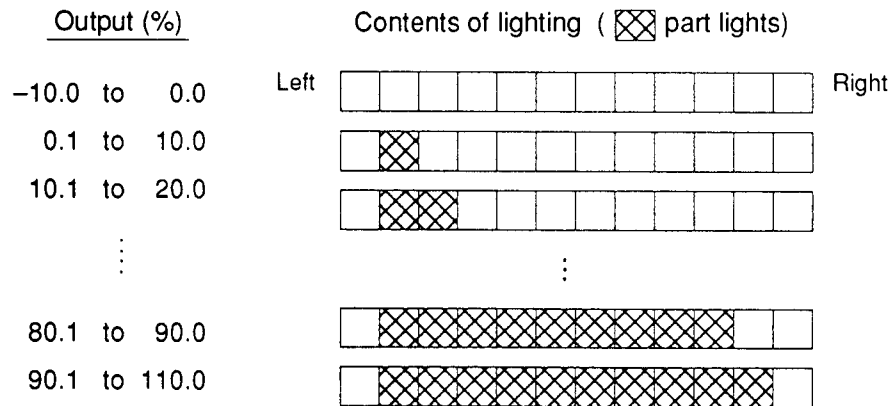

**1: OK lamp (green belt)**

The bar graph content LED (OUT LED) goes out.

When the instrument is in the READY mode, one second on and one second off are repeated alternately.

The READY mode indication is enabled only in this assignment, but it is disabled in any other assignment.

When the following conditions are all satisfied in the RUN mode, all the 12 segments light.

- $(SP - \text{Low limit of green belt}) \leq PV \leq (SP + \text{High limit of green belt})$
- The above continues for 5sec min.
- An alarm (AL) does not occur.

There is no hysteresis between the on and off of the OK lamp. This lamp goes out when the deviation exceeds the set value.

2: Motor opening monitor (MFB monitor in the 2G model only)

The bar graph content LED (OUT LED) goes out.

This LED lights according to the feedback (MFB) signal from the motor, as shown below

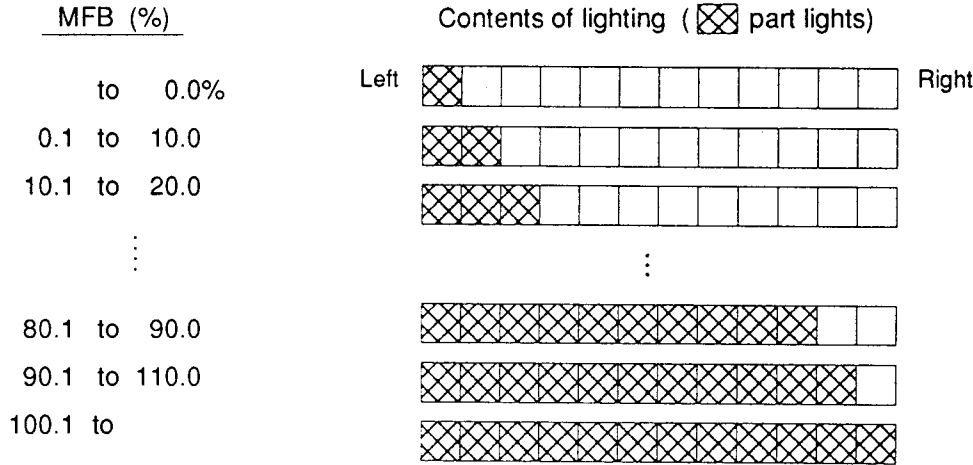

3: Event monitor (EV monitor)

The bar graph content LED (OUT LED) goes out.

The events 4 to 8 are assigned to the five segments, starting with the left end segment. When an event is turned on, the relevant segment lights, but the remaining segments do not light. The exclusive LEDs are prepared for the events 1 to 3.

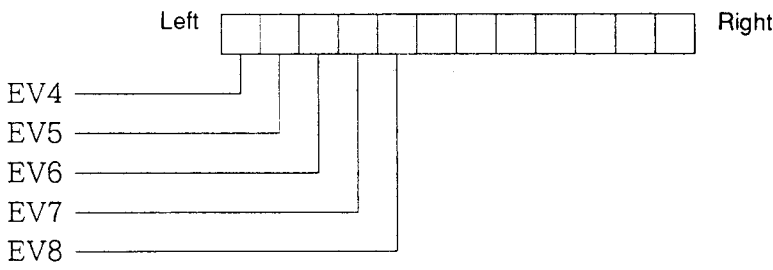

Example of indication:

- Event 4 is on, and the others are off.
- Event 8 is on, and the others are off.
- Events 4, 5 and 8 are on, and the others are off.

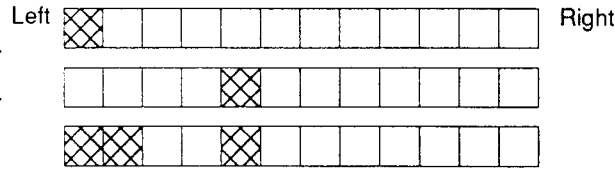

**4: Remote switch monitor (RSW monitor)**

The bar graph content LED (OUT LED) goes out. The RSW1 to 12 are assigned to all the 12 segments, starting with the left end. When an RSW is turned on, the relevant segment lights.

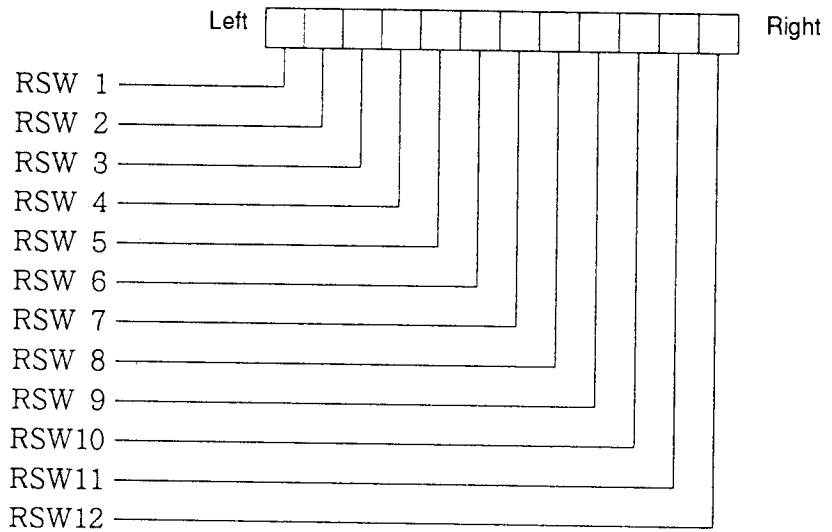

Example of indication:

The RSW1 and 3 are on, and the others are off.

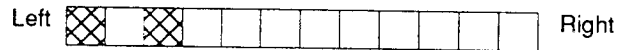

**C72: Input broken line approximation [ 0 ]**

It is selected in this setup where the broken line pattern set in PARA 59 to 80 is to be used.

- 0: Not used.
- 1: Used for AI1 (PV or PV1).
- 2: Used for AI2 (RSP or PV2).

C73: Unused.

C74: Unused.

**C75: RSP, C/B selection [ 0 ]**

It is determined in this setup whether or not the computer backup is to be executed.

- 0: RSP (normal remote SP type)
- 1: C/B (computer backup type)

When the computer backup is assigned to an RSW, be sure to set "1" in this setup.

C76: Selection of output system of time proportional output [ 0 ]

6D model only

If the longer cycle time is set in the 6D model, and the result of the PID operation is increased on the course of the cycle time, the output cannot be obtained till the next cycle time in the old system (1). When the initial value (0) is selected, the output can be obtained again within the same cycle time by the increment of the result of the PID operation.

0: Turned on again within the cycle.

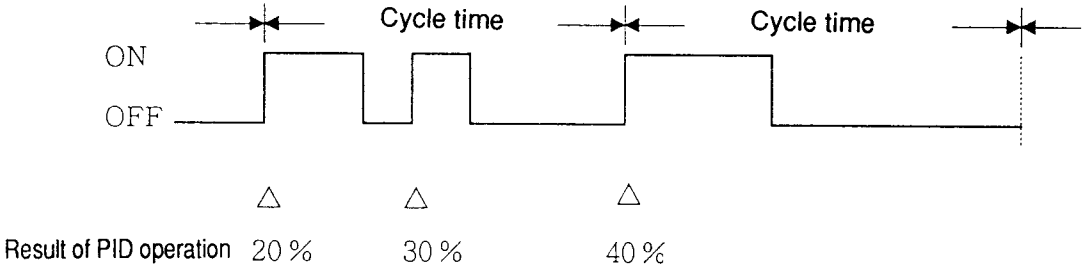

1: Not turned on within the cycle (normal system)

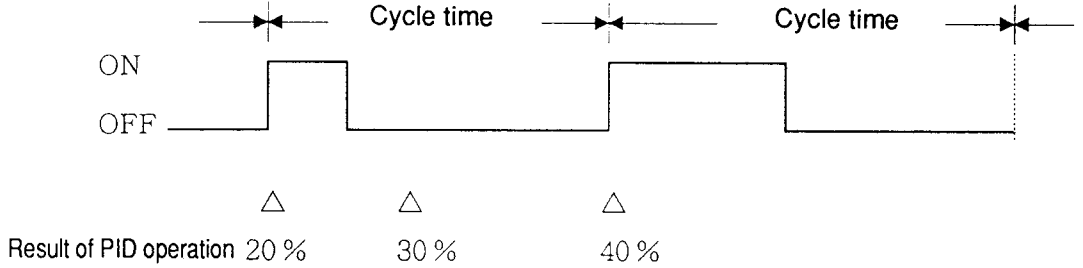

If the result of the PID operation increases during the on period, the on time is extended according to that result in each case. On the contrary, if the result of the PID operation decreases in such a case, the on time is shortened.

C77: Compensation of thermocouple cold junction [ 0 ]

The temperature of the wiring junction of a thermocouple can be compensated for, using an ice box or the like externally, without using the internal cold junction compensation function.

- 0: Inside
- 1: Outside

However, the external compensation temperature is intended to be 0°C only (an ice box, or the like is used as a precondition).

C78: S/W action in AI1 (PV or PV1) disconnection [ 0 ]

When the thermocouple, mV, or RTD input is applied, the direction of burnout can be determined by a switch.

- 0: Upscale
- 1: Downscale

C79: Adjustment of voltage output 1 ( $I_{1OUT}$ ) [ 15 ]  
 2 to 22mA

C80: Adjustment of voltage output 2 ( $I_{2OUT}$ ) [ 15 ]  
 2 to 22mA

When an SSR is driven in the 6D model, it is necessary that the output voltage of the instrument is put in the rated input voltage (optimum trigger voltage) range of that SSR. This instrument employs the variable output system newly developed so that an optimum trigger voltage can be output even when more than one SSR are driven. In this system, an appropriate current is set and output by this instrument so that an optimum trigger voltage may be obtained with respect to the internal impedance of the SSR side. The equivalent circuit of this system and the associated expressions are shown below.

[Description of Symbols]

[Contents]

- $I_0$  : Set output current of SDC40A (setting range: 2 to 22mA)
- $V_0$  : Load open voltage (approx. 14.6V)
- $V_{SSR'}$  : Actual input voltage to SSR
- $V_{SSR}$  : Rated SSR input voltage range ( $V_{SSR/MIN}$  to  $V_{SSR/MAX}$ )
- $V_{SSR/MIN}$  : Rated minimum input voltage of SSR
- $V_{SSR/MAX}$  : Rated maximum input voltage of SSR
- $Z$  : Internal impedance of SSR
- $V_D$  : Internal voltage drop of SSR (usually, approx. 1 to 2V)

[Equivalent Circuit with One SSR Connected]

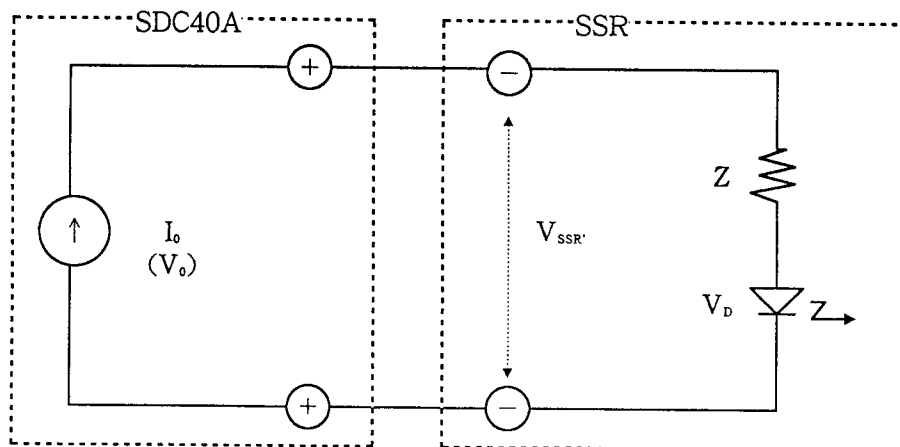

— Necessary expressions: The following two expressions must be satisfied.

$$V_{SSR/MIN} \leq I_0 \times Z + V_D \leq V_0 \quad \text{Expression ①}$$

$$V_{SSR'} \leq V_{SSR/MAX} \quad \text{Expression ②}$$

$$(V_{SSR'} = I_0 \times Z + V_D)$$

[Equivalent Circuit with n SSRs Connected in Series]

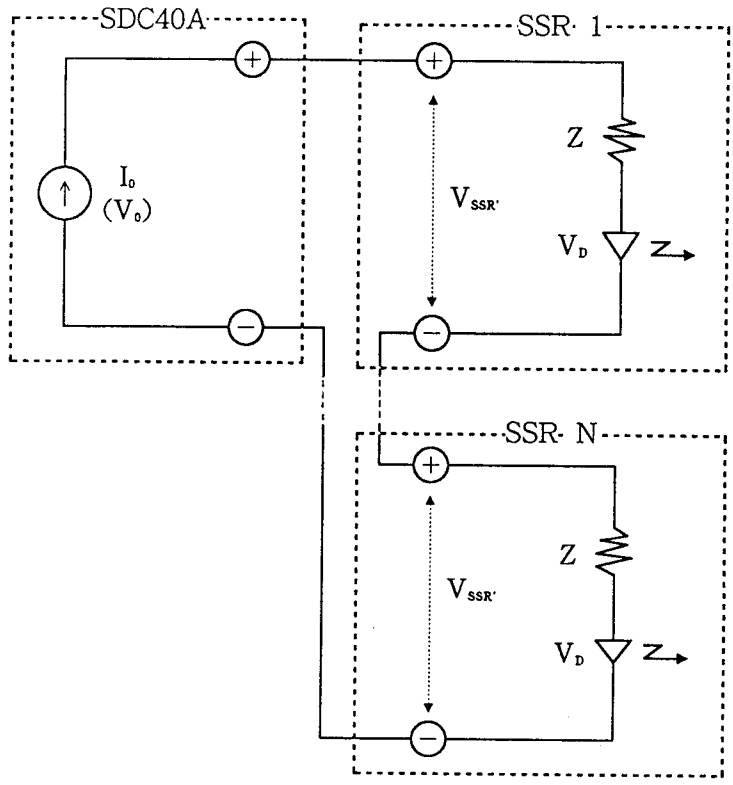

— Necessary expressions: The following two expressions must be satisfied.

$$V_{SSR/MIN} \leq I_0 \times Z + V_D \leq \frac{V_0}{n} \quad \text{Expression ③}$$

$$V_{SSR'} \leq V_{SSR/MAX} \quad \text{Expression ④}$$

$$(V_{SSR'} = I_0 \times Z + V_D)$$

[Equivalent Circuit with n SSRs Connected in Parallel]

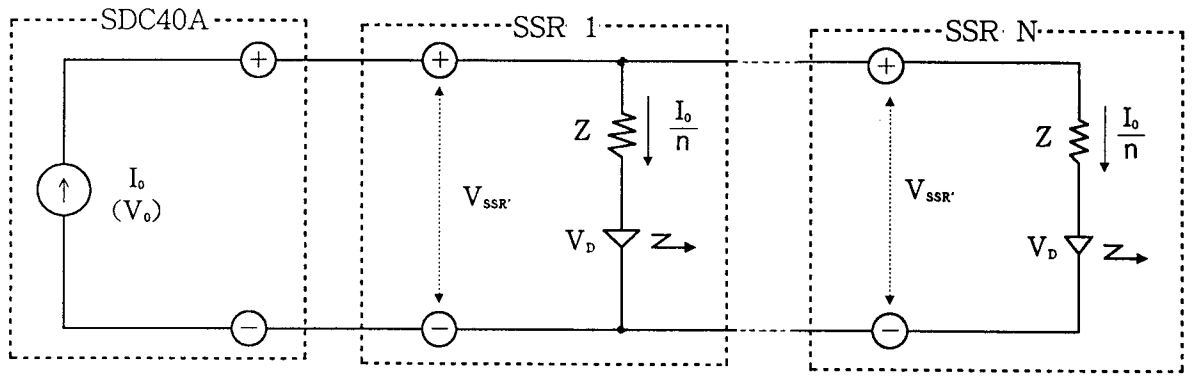

— Necessary expressions: The following two expressions must be satisfied.

$$V_{SSR/MIN} \leq \frac{I_0}{n} \times Z + V_D \leq V_0 \quad \text{Expression ⑤}$$

$$V_{SSR'} \leq V_{SSR/MAX} \quad \text{Expression ⑥}$$

$$(V_{SSR'} = \frac{I_0}{n} \times Z + V_D)$$

[Example; In case Honeywell PGM is used]

\* Specifications of Honeywell PGM (D2W110ED to 215ED)

- $V_{SSR}$  : 3 to 6V
- $V_{SSR/MIN}$  : 3V
- $V_{SSR/MAX}$  : 6V
- $Z$  : 220Ω
- $V_0$  : 1.6V

— How is the set value of  $I_0$  found, when one PGM is connected to the SDC40A ?

From the expression ①,  $V_{SSR/MIN} \leq I_0 \times Z + V_D \leq V_0$

When this expression is transformed,

$$\frac{V_{SSR/MIN} - V_D}{Z} \leq I_0 \leq \frac{V_0 - V_D}{Z}$$

$$0.0064 \leq I_0 \leq 0.059 \quad \text{Expression ①'}$$

From the expression ②,  $V_{SSR} \leq V_{SSR/MAX}$

$$I_0 \times 220 + 1.6 \leq 6$$

$$I_0 \leq 0.02 \quad \text{Expression ②'}$$

The set value of  $I_0$  can be selected from among 7mA to 20mA according to the expressions ①' and ②', so the set value of 15mA at delivery from the factory can be used as it is.

— How many PGMs can be connected in series ?

From the expression ③,  $V_{SSR/MIN} \leq I_0 \times Z + V_D \leq \frac{V_0}{n}$

$$3 \leq I_0 \times 220 + 1.6 \leq \frac{14.6}{n}$$

From the left side inequality,  $\frac{3 - 1.6}{220} \leq I_0$

$$\text{Therefore, } 0.0064 \leq I_0 \quad \text{Expression ③'}$$

From the right side inequality,  $n \leq \frac{14.6}{I_0 \times 220 + 1.6} \quad \text{Expression ③''}$

Therefore,  $n \leq 4.6$  when  $I_0 = 0.007$  (7mA).

$$\text{From the expression ④, } I_0 \leq 0.02 \quad \text{Expression ④'}$$

According to ③'',  $n$  is increased as  $I_0$  becomes smaller.

However, since there is a restriction of the expression ③', the maximum number of PGMs in series, which can be driven by the SDC40C, is 4 units. At this time, the set value of  $I_0$  may also be 7mA. If two PGMs are connected in series, the set value of  $I_0$  is within the range of 7mA to 20mA according to  $0.0064 \leq I_0 \leq 0.025$ , which is obtained from the expressions ③' and ③'' (when 2 is substituted for  $n$ ), and the expression ④', so the set value of 15mA at delivery from the factory can also be used as it is.

Similarly, the set value of  $I_0$  is within 6.4mA to 14mA when three PGMs are connected in series.

— How many PGMs can be connected in parallel ?

From the expression ⑤,  $V_{SSR/MIN} \leq \frac{I_0}{n} \times Z + V_D \leq V_0$

$$3 \leq \frac{I_0}{n} \times 220 + 1.6 \leq 14.6$$

$$0.0064 \leq \frac{I_0}{n} \leq 0.059$$

From the left side inequality,  $n \leq I_0 \times 156$  Expression ⑤'

From the expression ⑥,  $\frac{I_0}{n} \times Z + V_D \leq V_{SSR/MAX}$

$I_0 \times 50 \leq n$  Expression ⑥'

$I_0$  may take a maximum value according to the expression ⑥'.

Therefore,  $n \leq 3.43$ , when  $I_0 = 0.022$ .

Namely, up to three PGMs can be connected in parallel with the SDC40A.

— Which should be selected, series connection or parallel connection ?

When the internal impedance of SSR is small as in the abovementioned example, the series connection of SSRs is more suitable.

C81: Extension setting 1 [ -- ]

C82: Extension setting 2 [ 0 ]

0: Extension is not provided.

1: Extension is provided.

C83: Extension setting 3 [ 0 ]

0: Extension is not provided.

1: Extension is provided.

The extension settings 1, 2 and 3 are used for maker service. Usually, don't change the figure in brackets [ ], which is the set value at delivery from the factory.

C84: Communication address [ 0 ]

Only when communication (OP) is provided

0 to 127

When "0" is set in this setup, the communication is disabled. If instruments having the same address (other than 0) exist on the same communication line, these instruments may be damaged by the communication. Be sure to change their addresses.

Only when communication (OP) is provided

- C85: Transmission speed and code [ 0 ]
  - 0: 9600bps, even parity, 1 stop bit
  - 1: 9600bps, non parity, 2 stop bits
  - 2: 4800bps, even parity, 1 stop bit
  - 3: 4800bps, non parity, 2 stop bits

C86: Unused

C87: "

C88: "

C89: "

C90: Special function 1 [ 0 ]

C91: " 2 [ -- ]

C92: " 3 [ -- ]

C93: " 4 [ -- ]

C94: Unused

C95: "

C96: Hardware type 1

C97: Hardware type 2

C98: ROM ID

C99: ROM item

C00: ROM revision

C81 to C83, and C86 to C95 are all used for maker service. Never change the set values of these setup items. Otherwise, this instrument may malfunction. C96 to C00 permit only the indication of the contents, and they cannot be changed.

— MEMO —

# Chapter 8 USER FUNCTION KEYS UF1 AND UF2

## 8-1 How to Use the User Function Keys

The SDC40A is provided with two user function keys (UF1 and UF2) as standard so that the user himself can register the key functions. The operation time cannot only be shortened by registering the functions to be used frequently, but also careless operations can be prevented by using the key lock function together. The instrument is equipped with these operator's oriented keys to make the high level functions compatible with the simple operation.

All the contents of PARA, PID, SETUP, SP and EV as well as the mode selection functions of A/M, R/L, AT, and RUN/READY can be registered.

Up to 4 functions can be registered in the UF1 key, and up to 8 functions in the UF2 key. When one mode selection function is registered in one user function key, any other function cannot be registered in it any longer.

When PARA, PID, SETUP, SP and EV are registered, they can be called in the item code order one by one every time a user function key is pressed, and the set contents can be readily changed. The original status can be restored by pressing the <sup>DISP</sup> key. When a mode selection function is registered, the relevant mode is set immediately by pressing the UF key, and the original mode is restored by pressing it again.

When a SETUP item is registered, that item can be changed even in other than the READY mode.

Example: Change of SP value

[Normal change method]

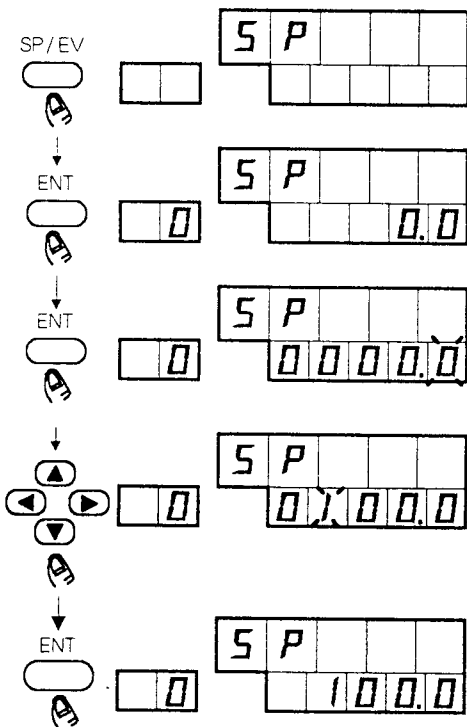

[Change method using UF key]

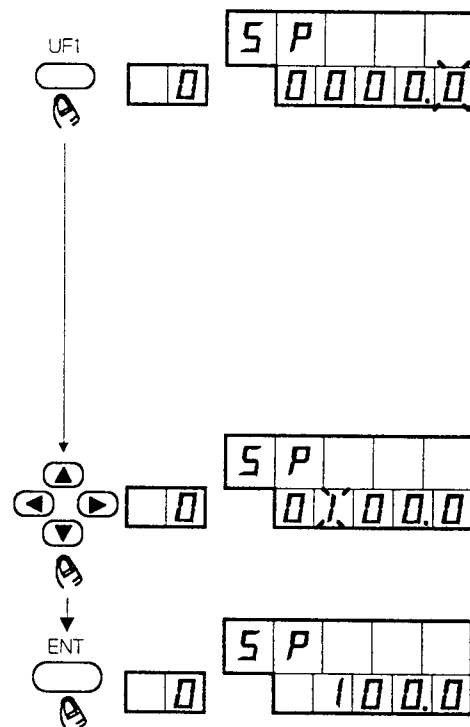

## 8-2 How to Register a Function in User Function Key



1. Item code range for register

SETUP items : C55 to C59 (UF1 key), C60 to C68 (UF2 key)

2. Registering method

The UF1 key registering method is described below. The UF2 key registering method is the same as in the UF1 key, although the number of functions which can be registered is increased up to 8 functions.

- ① Execute the basic register for registering a function in the UF1 key by C55.

Mode selection function	0:	Not registered.
	1:	AUTO/MAN (the same function as the  key)
	2:	REM/LOC (the same function as the  key)
	3:	AT (the same function as the  key)
	4:	RUN/READY (RUN/READY selection is executed by once key operation)
	5:	Selection from among SP, EV, PARA, PID, and SETUP items

"1" to "4" above are included in the mode selection function. When the mode selection function is registered in the UF1 key, any other function cannot be registered in it any longer. As for "5" above the four functions selected from among the individual items arbitrarily can be registered in the UF1 key (8 functions in the UF2 key). The contents of assignment are selected by C56 to C59.

- ② Select the contents of assignment from among the SP, EV, PARA, PID and SETUP items by C56 to C59. Add the following radix predetermined every item to Guide No. of each function, and input the result to register the contents.

Item	Radix
SP	: + 4000
EV	: + 4500
PID	: + 5000
PARA	: + 5500
SETUP	: + 6000

3. Release of register

To keep the UF key unused, input "0" in C55 (UF1 key) or C60 (UF2 key). To release the register of the contents assigned to C56 to C59 (UF1 key) or C61 to C68 (UF2 key), input an inexistent item number. For example, the above-mentioned radix (4000, 5000 ..... ) is an inexistent item number. When a radix is input, the registered contents are released. The set value at delivery from the factory is "0". Once any numeric is set, any value less than "4000" cannot be selected any longer by the operation of the setting range limiter to assure safety.

4. Example of registering

The definite procedure for registering SP0 in the UF1 key is shown below.

- ① Set the READY mode.

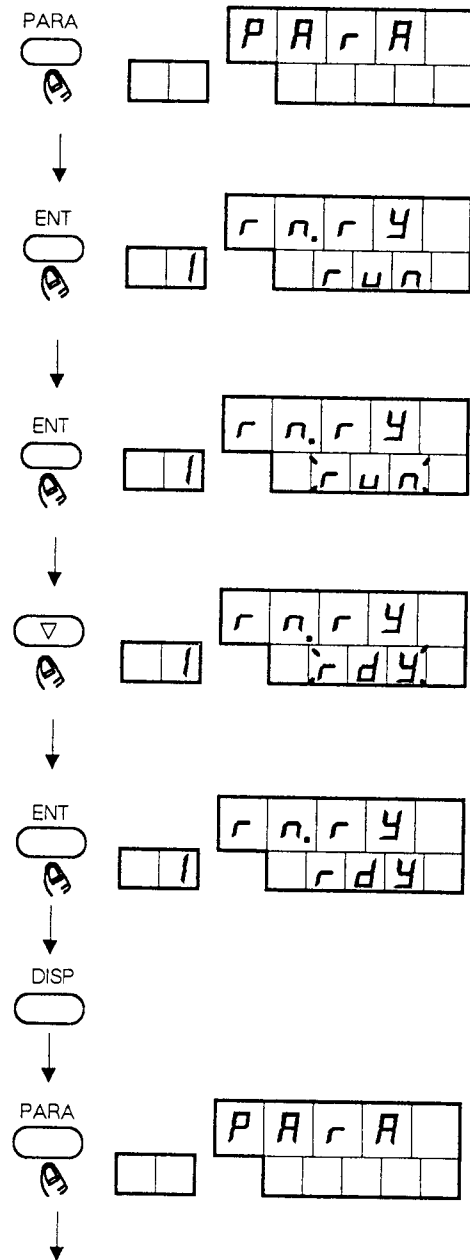

- ② Call the SETUP, and input item [5] (PARA, PID, SETUP, SP, EV register). Further, input 4002 (4000 + 2 (Guide No. of SP0) ) in C56 to call SP0.

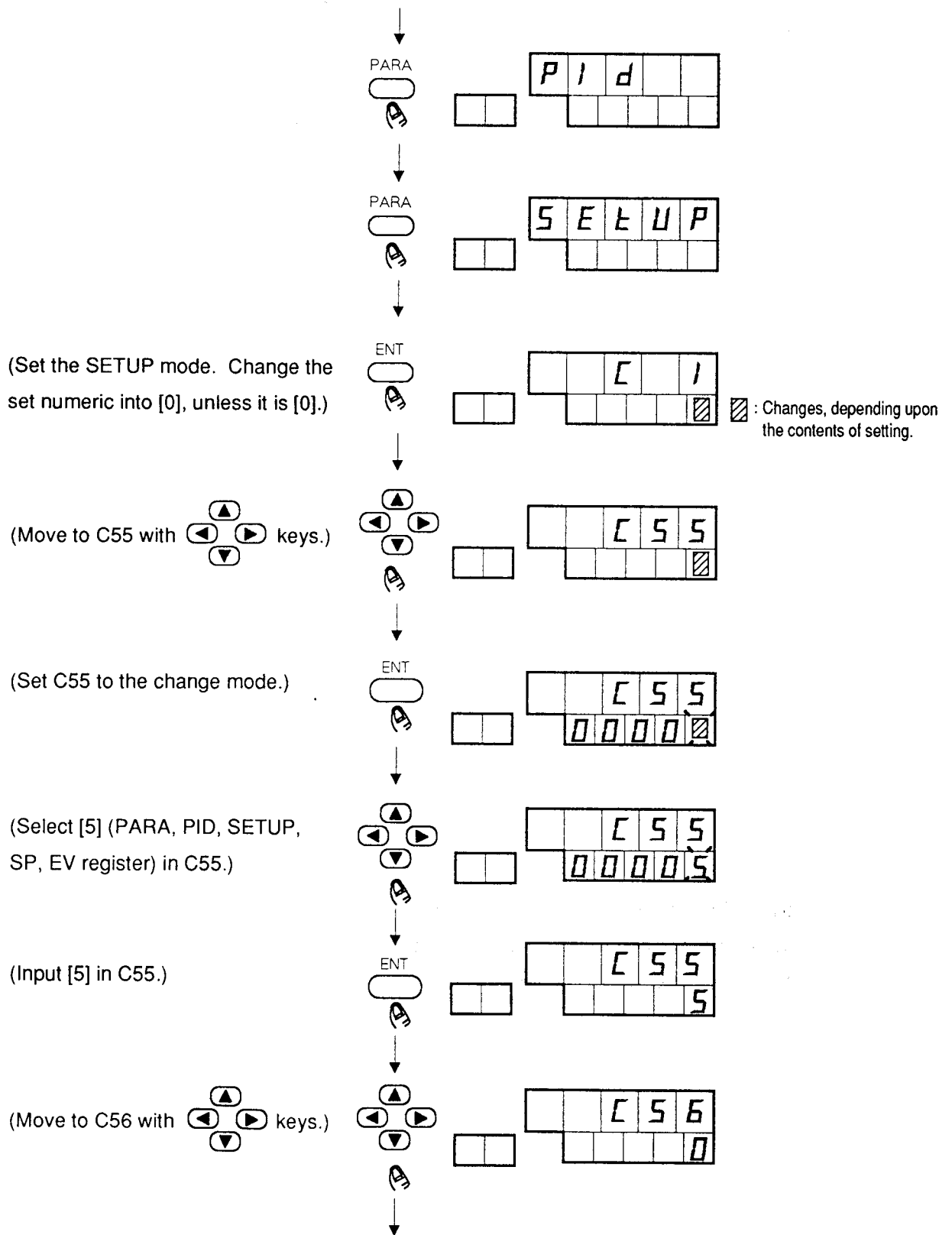

(Set C56 to the change mode.)

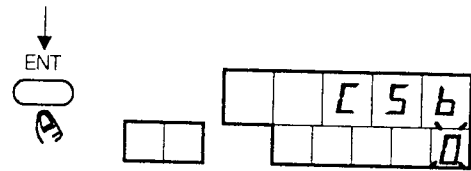

(Select [4002] in C56.)

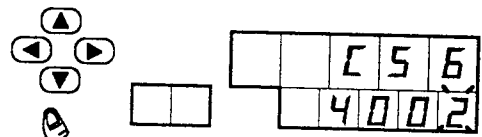

(Input [4002] in C56.)

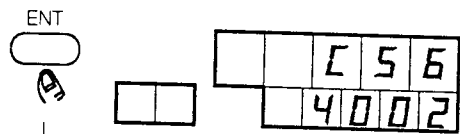

(Press the <sup>DISP</sup> key to reset to the basic indication status.)







# Chapter 9 OPERATION

## 9-1 Power ON

The SDC40A main body is not provided with a power switch or protective fuse. If necessary, provide them outside the instrument.

Supply the power of 90 to 264V AC between the terminals ① and ② of the main body. The instrument starts up about 10 sec after to begin the indication and control. During the start-up time, the 10 LEDs of the bar graph indicator light sequentially at unequal intervals, starting with the second LED as counted from the lefthand side.

## 9-2 Indication Changeover

When the  key is pressed, the indications of No. 2 indicator and No. 3 indicator are changed over as shown below. Since this has no effect on the control, the necessary indications can be checked selectively, as required. The contents of indication of the bar graph indicator are determined, depending upon the setting of C71, and cannot be changed by the  key.

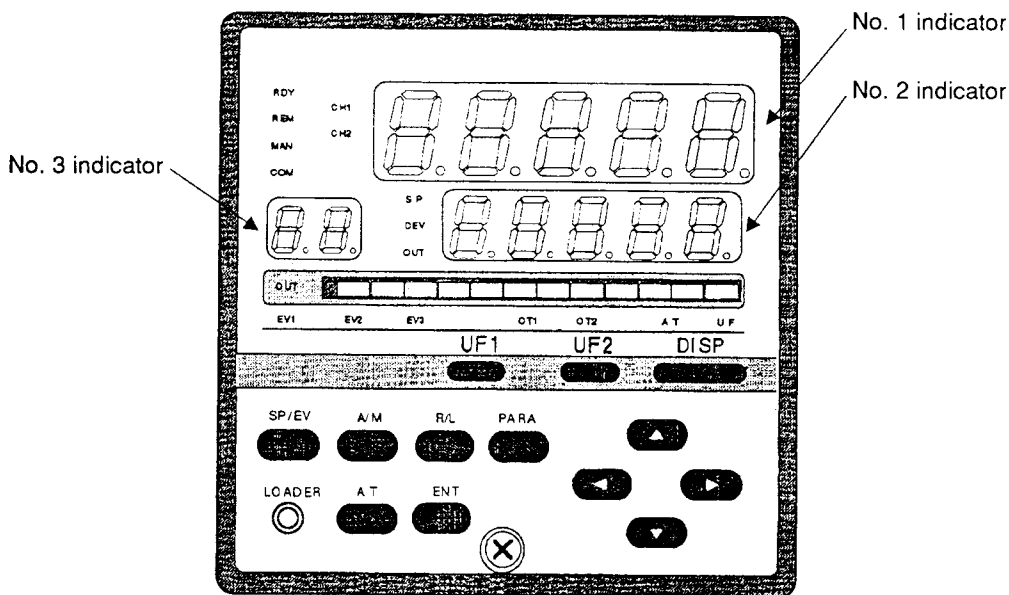

### (1) Standard model and remote SP model

There are six indication types ① to ⑥ as shown on the next page. Immediately after the power supply is turned on, the indication type ① is indicated in the AUTO mode, and the indication type ③ in the MANUAL mode.

The indication type is changed over repeatedly as shown below, depending upon the output model.

In case of 0D, 6D, 5G output : ① → ② → ③ → ① → .....

In case of 2G output : ① → ② → ③ → ④ → ① → .....

In case of heat/cool output : ① → ② → ③ → ⑤ → ⑥ → ① → .....

- ① No. 1 indicator : PV  
No. 2 indicator : SP  
No. 3 indicator : • Goes out with one LSP.  
• In the LSP mode with 8 LSPs, the selected LSP number (0 to 7) is indicated.  
• In the RSP mode with 8 LSPs, [**r**] denoting RSP is indicated at the left digit, and the selected LSP No. (0 to 7) is indicated at the right digit.  
SP, DEV, OUT lamp : SP lights.
- ② No. 1 indicator : PV  
No. 2 indicator : Deviation (DEV). This is a value calculated from PV – SP.  
No. 3 indicator : Goes out.  
SP, DEV, OUT lamp : DEV lights.
- ③ No. 1 indicator : PV  
No. 2 indicator : Manipulated variable output %  
(A changeable digit flashes in MANUAL mode.)  
No. 3 indicator : Goes out.  
SP, DEV, OUT lamp : OUT lights.
- ④ This indication is given in the 2G output type only.  
No. 1 indicator : PV  
No. 2 indicator : Motor opening %  
No. 3 indicator : [**Fb**] is indicated.  
SP, DEV, OUT lamp : Goes out.
- ⑤ This indication is given in the heat/cool output type only.  
No. 1 indicator : PV  
No. 2 indicator : Heat side output %  
No. 3 indicator : [**HE**] is indicated.  
SP, DEV, OUT lamp : OUT lights.
- ⑥ This indication is given in the heat/cool output type only.  
No. 1 indicator : PV  
No. 2 indicator : Cool side output %  
No. 3 indicator : [**CL**] is indicated.  
SP, DEV, OUT lamp : OUT lights.

(2) Internal cascade model

There are seven indication types ① to ⑦ as shown below. Immediately after the power supply is turned on, the indication type ① is indicated in the AUTO mode, and the indication type ④ in the MANUAL mode.

The indication type is changed over repeatedly as shown below, depending upon the output model.

In case of 0D, 6D, 5G output : ① → ② → ③ → ④ → ① → ……

In case of 2G output : ① → ② → ③ → ④ → ⑤ → ① → ……

In case of heat/cool output : ① → ② → ③ → ④ → ⑥ → ⑦ → ① → ……

- ① No. 1 indicator : Master PV
- No. 2 indicator : Master SP (M – LSP)
- No. 3 indicator : • Goes out with one master SP.  
• Selected LSP No. (0 to 5) is indicated with six master SPs.
- SP, DEV, OUT lamp : SP lights.
- CH indication : CH1 lights.
  
- ② No. 1 indicator : Master PV
- No. 2 indicator : Master OUT
- No. 3 indicator : Goes out.
- SP, DEV, OUT lamp : OUT lights.
- CH indication : CH1 lights.
  
- ③ No. 1 indicator : Slave PV
- No. 2 indicator : Slave SP (S – LSP)
- No. 3 indicator : • Selected LSP number (6 or 7) is indicated in the LSP mode.  
• [  ] denoting RSP is indicated at the left digit, and selected RSP number (6 or 7) at the right digit.
- SP, DEV, OUT lamp : SP lights.
- CH indication : CH2 lights.
  
- ④ No. 1 indicator : Slave PV
- No. 2 indicator : Slave OUT (control output quantity)
- No. 3 indicator : Goes out.
- SP, DEV, OUT lamp : OUT lights.
- CH indication : CH2 lights.

- ⑤ No. 1 indicator : Slave PV
- No. 2 indicator : Motor opening %
- No. 3 indicator : [ **Fb** ] is indicated.
- SP, DEV, OUT lamp : Goes out.
- CH indication : CH2 lights.
  
- ⑥ No. 1 indicator : Slave PV
- No. 2 indicator : Heat side output % (control output quantity)
- No. 3 indicator : [ **HL** ] is indicated.
- SP, DEV, OUT lamp : OUT lights.
- CH indication : CH2 lights.
  
- ⑦ No. 1 indicator : Slave PV
- No. 2 indicator : Cool side output % (control output quantity)
- No. 3 indicator : [ **CL** ] is indicated.
- SP, DEV, OUT lamp : OUT lights.
- CH indication : CH2 lights.

### 9-3 Setting of SP and SP Number

SP: Set Point (set value)

(1) Prior to SP setting

How to set a reference value (SP) for actual control is described below.

There are an LSP and an RSP as SPs. The LSP is set by key operation from the console, and the RSP is set by a signal given from outside. Up to eight LSPs are stored by the setup operation, and they can be called and used by the keys or RSWs. This is called a multi SP function. An arbitrary PID group number is assigned to each LSP or RSP so that the optimum control may be done, and in addition, the settable ranges can also be limited by setting the SP limit values, thus preventing a malfunction from occurring.

- LSP : Local Set Point
- RSP : Remote Set Point
- RSW : Remote Switch

There are the following other set items related with the SP setting. If a trouble should occur in SP setting, recheck these items.

Parameter setting items (PARA)

- 33: *SPU* LSP up ramp
- 34: *SPd* LSP down ramp
- 35: *rSPU* RSP up ramp
- 36: *rSPd* RSP down ramp
- 37: *rA-t* Setting of SP ramp unit

Setup items (SETUP)

- C1 : Key lock
- C16: LSP setting system
- C17: Low limit of SP limit
- C18: High limit of SP limit
- C42 to C53: RSW assignment  
(When an LSP is selected by the RSW, it cannot be selected from the console.)

(2) How to set and reset the SP setting mode

SP values can be set even in any selection mode of RUN/READY, AUTO/MAN and REMOTE/LOCAL, etc., unless PARA, PID, or SETUP item setting is being executed, and key lock is applied.

Press the <sup>SP/EV</sup> key, and the following three (two unless the multi SP function is used) setting groups can be called in turn. Further, press the <sup>ENT</sup> key, and each setting can be done. To reset the SP setting mode, press the <sup>DISP</sup> key in any status. The basic indication status can be restored.

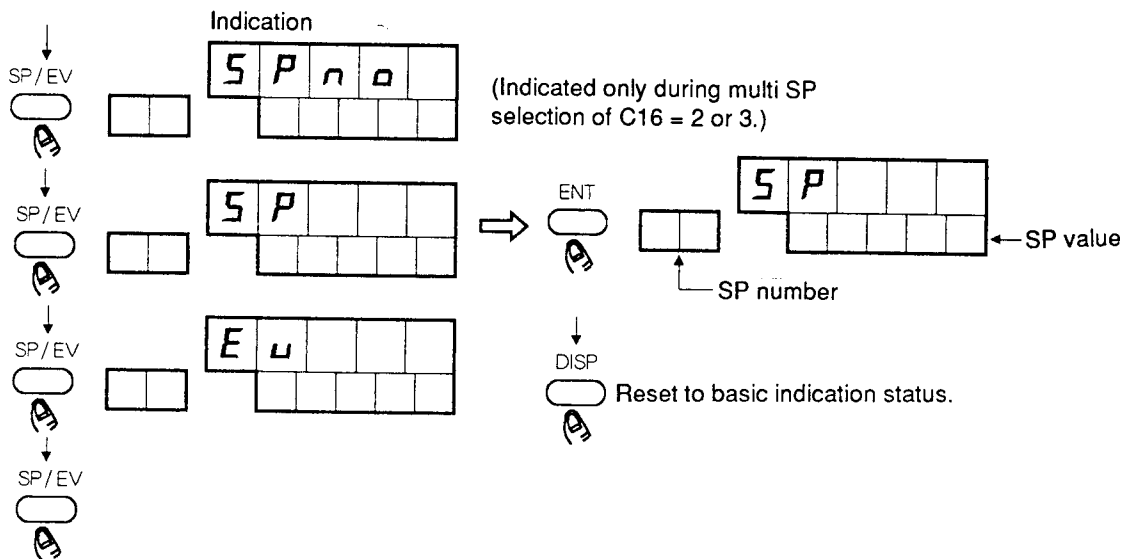



(3) How to move an SP item



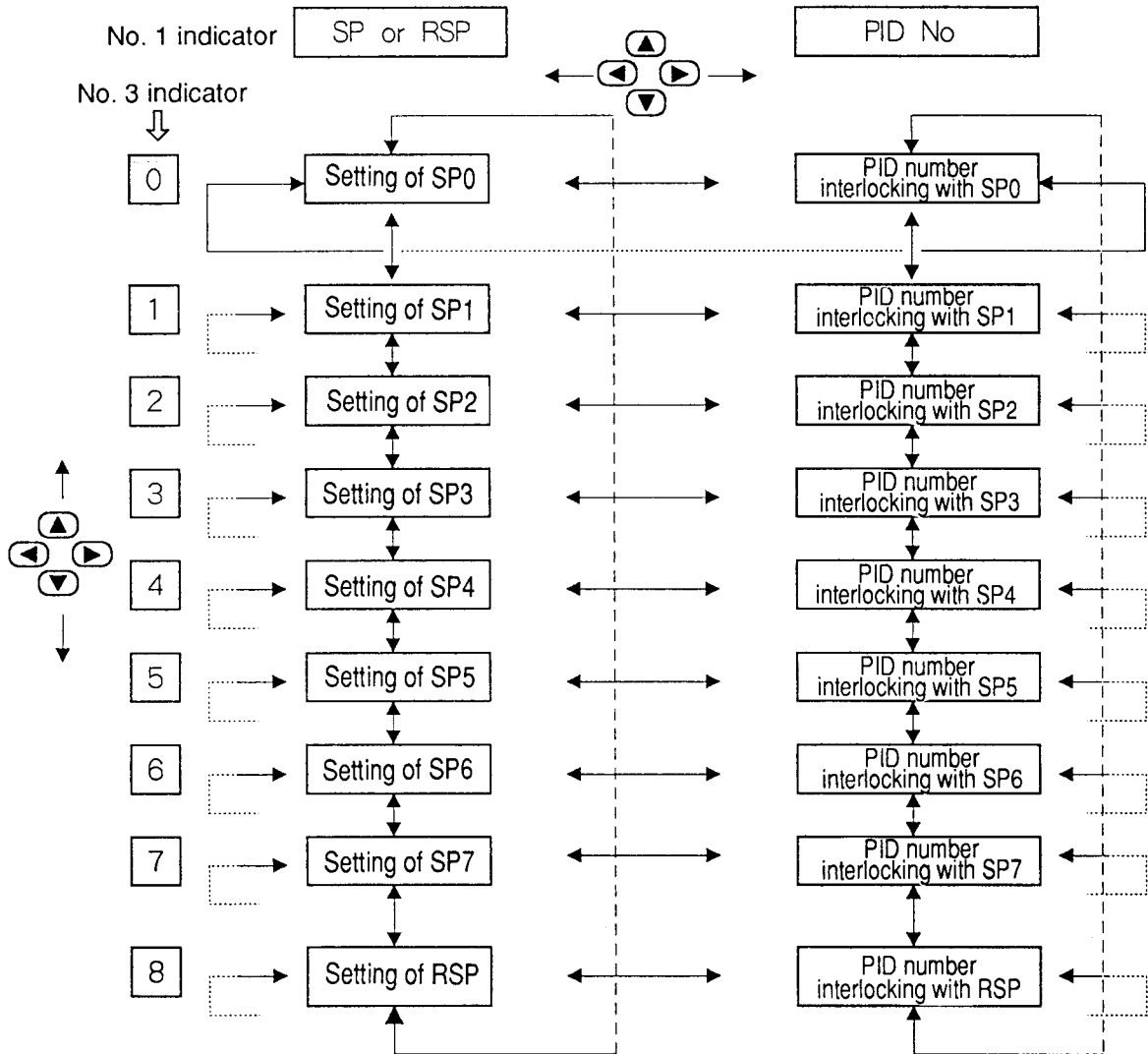

The SP items have a simple matrix construction together with the selection of PID numbers used as shown below. Each item can move optionally with  keys.

When "0" or "1" is set in the setup C16, the settings of SP1 to SP7 are skipped, but those of SP1 to SP5 are skipped in the internal cascade model.



(4) How to change the set value of SP item

To change the set value of an SP item, press the  key when that item is indicated. Since the set value on No. 2 indicator flashes to indicate that the set value can be readily changed, set a desired value with  keys, and press the  key again. The set value is stored, and flashing stops. An RSP item is only indicated, but cannot be changed. The remote SP value can be checked even in the local mode. When "3" is set in C16, the SP value change input is not accepted.

To restore the previous value during flashing of the set value, press not the  key, but the  key. After the basic indication status is restored, execute the same setting operation, or go to the next item with the  key, and then return to the original item with  key. The present set value is not stored, but the previous set value is maintained.

(5) Selection of SP number (SP No.)

When "2" or "3" is set in C16, and an LSP number is not selected by an RSW, an SP number can be selected from the console as shown below.

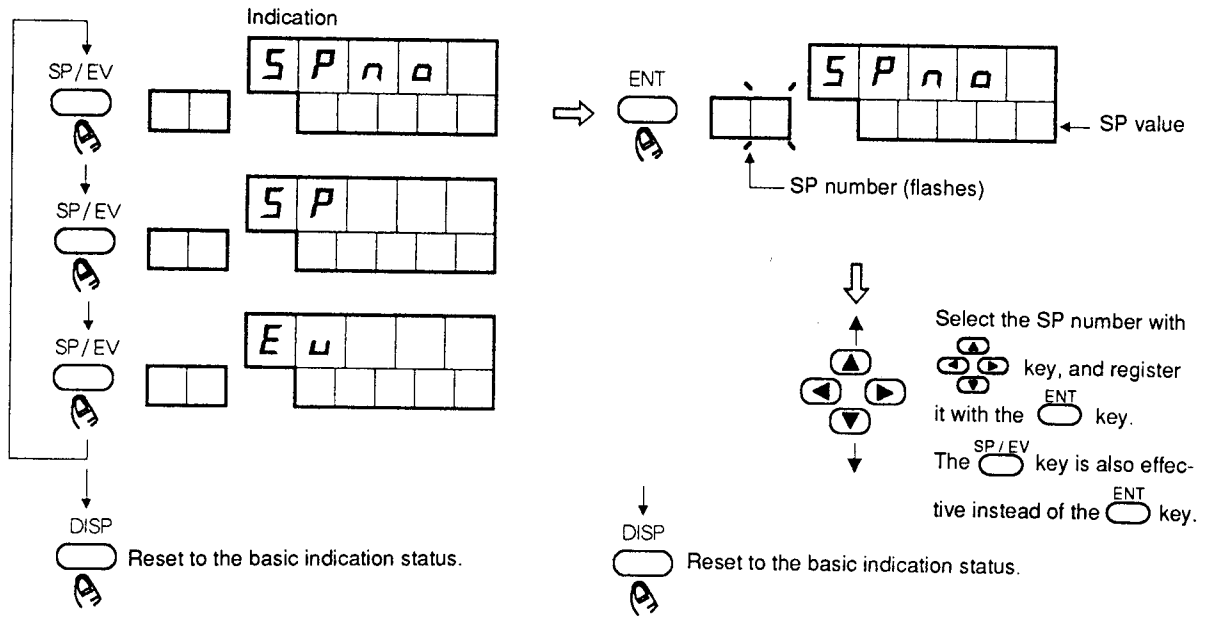

(6) SP item table (including the selection of LSP group number)

Guide No.	Item code	Item	Set value at delivery from factory	User's setting column	Setting
1	S P n o	Selection of LSP group number	0		0 to 7 Supplement When C16 = 0 or 1, this item is skipped. Or, when the LSP selection is assigned to an RSW, it is also skipped.
2	S P * 2 N N N N N 0	LSP0 value	0U		<ul style="list-style-type: none"> <li>When C16 = "0" or "1", LSP1 to 7 are not indicated. When the C16 value is set to "2" once, and each SP value is changed, its value is stored even if the C16 value is changed into "0" or "1" and reset to "2" again.</li> <li>Each of LSP and RSP is limited by the low limit of SP limit (C17) and the high limit of SP limit (C18).</li> <li>In the internal cascade model, LSP (master side SP) is not limited, but it is within the range of -19999 to 26000U.</li> <li>In the internal cascade model, LSP6 and LSP7 are used as the slave side LSPs.</li> </ul>
3	S P N N N N N 1	LSP1 value	0U		
4	S P N N N N N 2	LSP2 value	0U		
5	S P N N N N N 3	LSP3 value	0U		
6	S P N N N N N 4	LSP4 value	0U		
7	S P N N N N N 5	LSP5 value	0U		
8	S P N N N N N 6	LSP6 value	0U		
9	S P N N N N N 7	LSP 7 value	0U		
10	r S P * 3 A A A A A B	RSP value	—		

\*1. Upper stage : No. 1 indicator  
Middle stage : No. 2 indicator  
Lower stage : No. 3 indicator

\*2. The contents of NNNNN differ, depending upon the setting item.

\*3. AAAAA denotes the set value of a remote SP.

Guide No.	Item code	Item	Set value at delivery from factory	User's setting column	Setting
11	P I d n o 0	Designation of PID number (when LSP0 is used)	0 [0]		<ul style="list-style-type: none"> <li>The designation range of a PID number is usually within 0 to 7. In the heat/cool model, however, it is within 0 to 3, and when any of 4 to 7 is set, it is regarded as 0.</li> <li>In the internal cascade model, only the setting of PID Nos. 0 to 5 with respect to LSP0 to 5, and the setting of PID Nos. 6 and 7 with respect to the slave side LSP6 and 7 are permitted.</li> <li>Figure in brackets [ ] denotes the set value at delivery from the factory in case of the cascade model.</li> <li>A PID number is designated to operate it, interlocking with each of LSP or RSP. If another PID number is selected by an RSW, this has priority over the above designation, and the interlocking is cut off. When it is then desired to identify what PID number is used, select the PID number by the  key from the console. The PID number indicated at first is that which is used currently.</li> </ul>
12	P I d n o 1	Designation of PID number (when LSP1 is used)	0 [0]		
13	P I d n o 2	Designation of PID number (when LSP2 is used)	0 [0]		
14	P I d n o 3	Designation of PID number (when LSP3 is used)	0 [0]		
15	P I d n o 4	Designation of PID number (when LSP4 is used)	0 [0]		
16	P I d n o 5	Designation of PID number (when LSP5 is used)	0 [0]		
17	P I d n o 6	Designation of PID number (when LSP6 is used)	0 [6]		
18	P I d n o 7	Designation of PID number (when LSP7 is used)	0 [6]		
19	P I d n o 8	Designation of PID number (when RSP is used)	0 [6]		

### 9-4 EV Setting

EV: Event (alarm or the like)

(1) Prior to EV setting

How to set an EV value to be actually set is described below. There are the following other setting items related with the EV setting such as the EV type.

**Parameter setting items**

- 15: **E<sub>t</sub> I**      Event 1 type
- 16: **E<sub>d</sub> I**      Event 1 stand-by
- }                    }
- 29: **E<sub>t</sub> B**      Event 8 type
- 30: **E<sub>d</sub> B**      Event 8 stand-by
- 31: **dL<sub>t</sub>**        Event on delay time unit

(2) How to set and reset the EV setting mode

EV values can be set even in any selection mode of RUN/READY, AUTO/MAN and REMOTE/LOCAL, etc., unless PARA, PID, or SETUP item setting is being executed, and key lock is applied.

Press the <sup>SP/EV</sup> key, and the following three (two unless the multi SP function is used) setting groups can be called in turn. Further, press the <sup>ENT</sup> key, and each setting can be done. To reset the SP setting mode, press the <sup>DISP</sup> key in any status. The basic indication status can be restored.

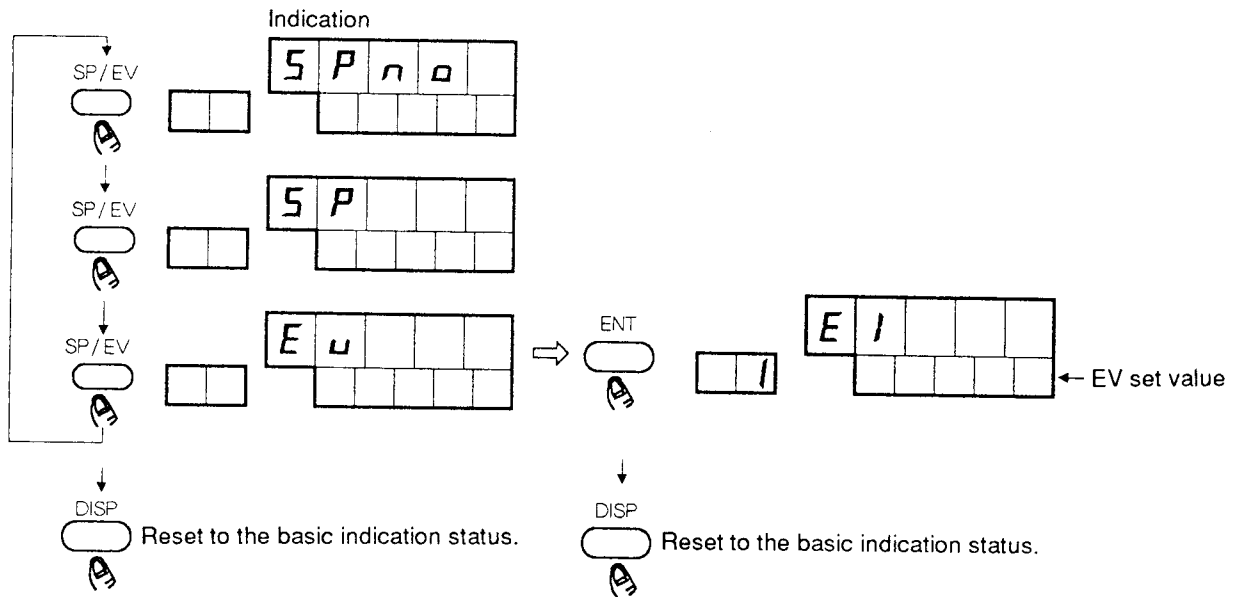



(3) How to move each EV item

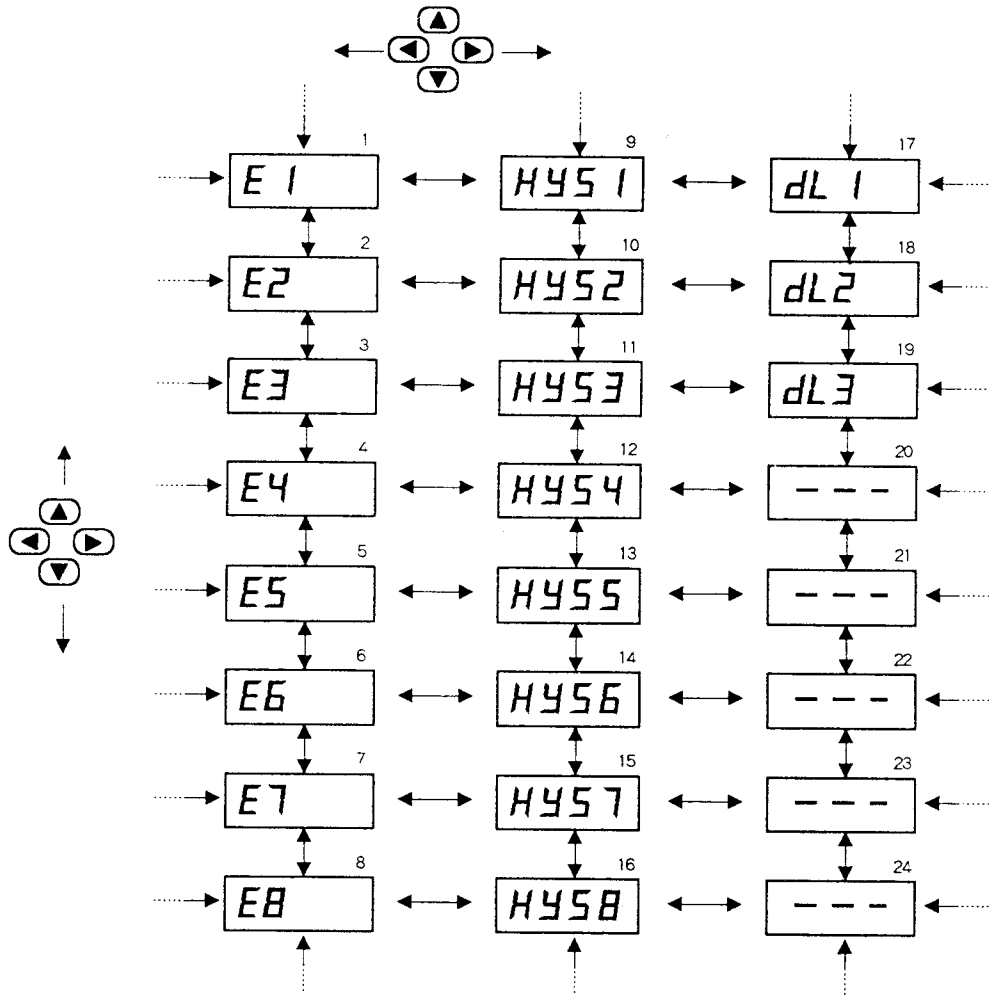

The EV items have a matrix construction together with the respective differential gaps and the setting of on delay time (in EV1 to 3 only) as shown below, and each EV item can be moved optionally with  keys.

2 EVs, 3 EVs or 8 EVs are available according to the model number. The figure at the right top of each frame denoting an item indicates Guide No. The same number is indicated on No. 3 indicator.



(4) How to change the set value of EV item

To change the set value of an EV item, press the  key when this item is indicated. The set value on No. 2 indicator flashes to indicate that it can be readily changed. Set a desired value with  keys, and press the  key again. The set value is stored and flashing stops.

To restore the previous value while the set value flashes, press not the  key, but the  key. After the basic indication status is restored, repeat the same setting operation.

(5) EV item table

Guide No.	Item code	Item	Set value at delivery from factory	User's setting column	Setting
1	E1	Set value of event 1	26000U		PV : -19999 to 26000U DEV : -19999 to 26000U   DEV   : 0 to 26000U RSP : -19999 to 26000U SP : -19999 to 26000U MV : -10.0 to 110.0% MFB : -10.0 to 110.0% Process : -10.0 to 110.0%  • When the event type is 15 to 21, or 34, indication is not given (setting is disabled).  • The above-mentioned setting ranges are effective, only when the event types are set earlier.
2	E2	Set value of event 2	26000U		
3	E3	Set value of event 3	26000U		
4	E4	Set value of event 4	26000U		
5	E5	Set value of event 5	26000U		
6	E6	Set value of event 6	26000U		
7	E7	Set value of event 7	26000U		
8	E8	Set value of event 8	26000U		

Guide No.	Item code	Item	Set value at delivery from factory	User's setting column	Setting	
9	H451	Event 1 hysteresis (differential gap)	50U		PV : 0 to 200U DEV : 0 to 200U  DEV  : 0 to 200U RSP : 0 to 200U SP : 0 to 200U MV : 0.0 to 20.0% MFB : 0.0 to 20.0% Process: 0 to 200U  • When the event type is 15 to 21, or 34, no indication is given (setting is disabled).	
10	H452	Event 2 hysteresis (differential gap)	50U			
11	H453	Event 3 hysteresis (differential gap)	50U			
12	H454	Event 4 hysteresis (differential gap)	50U			
13	H455	Event 5 hysteresis (differential gap)	50U			
14	H456	Event 6 hysteresis (differential gap)	50U			
15	H457	Event 7 hysteresis (differential gap)	50U			
16	H458	Event 8 hysteresis (differential gap)	50U			
17	dL1	Event 1 on delay time	0			0 to 20000s or min  • Functions only in event 1 to 3. Not provided for event 4 to 8.  • s or min is selected in Parameter No. 31
18	dL2	Event 2 on delay time	0			
19	dL3	Event 3 on delay time	0			

Guide Nos. 20 to 24 are blank, so none can be set in them.

— MEMO —

## Chapter 10 TROUBLESHOOTING

### 10-1 Alarm Indication

If an input error or instrument error is detected in the basic indication status (when each setting mode of PARA, PID, SETUP, SP No., SP, and EV is not set), the SDC40A gives an alarm code indication and normal indication on No. 1 indicator alternately every 1s. If more than one error have occurred, the alarm code given in the alternate indication is changed over in turn, starting with a younger error code.

Alarm code	Name of alarm	Contents	Remedial measure
AL01	AI1 overrange	AI1 exceeds 110% FS.	Check AI1 input.
AL02	AI1 underrange	AI1 is reduced below -10% FS.	
AL03	AI2 overrange	AI2 exceeds 110% FS. (*1)	Check AI2 input.
AL04	AI2 underrange	AI2 is reduced below -10% FS. (*1)	
AL07	RTD disconnection A	A wire of RTD is disconnected.	Check whether or not RTD (resistance thermometer bulb) connected to AI1 is disconnected or terminal connection is proper.
AL08	RTD disconnection B	B wire of RTD is disconnected, or all A, B and C wires are disconnected.	
AL09	RTD disconnection C	C wire of RTD is disconnected.	
AL10	MFB disconnection	One or all of Y, T, and G wires of MFB are disconnected.	Check wiring of MFB (motor feedback).
AL11	MFB short circuit	Y-G or Y-T-G short circuit.	
AL12	MFB adjustment failure	Miswiring or motor trouble	Check MFB or on/off relay wiring.
AL70	A/D1 fault	A/D converter 1 is defective.	Ask for repair.
AL71	A/D2 fault	A/D converter 2 is defective.	
AL80	Output configuration error	Output configuration is not adaptable to hardware.	There is possibility that this error can be corrected at site. Contact nearest YH representative.
AL97	Parameter error	Set value is abnormal. (*2)	Reset abnormal PARA, PID or SETUP item. When there is no error in them, reset the following 3 items. <ul style="list-style-type: none"> <li>• Proportional band 0 (P-0)</li> <li>• SP up ramp (SPU)</li> <li>• Indication 1 digit masking (dl SP)</li> </ul> If error occurs again, ask for repair.
AL98	Adjusting value error	AI or AO data is destroyed.	Ask for repair.
AL90	ROM error	ROM data is destroyed.	Ask for repair.

\*1: In the remote SP model, AL03 and 04 are not indicated in the LOCAL mode.

\*2: If power failure occurs within 10s after each setting is done, AL97 alarm may be issued even when the set values are normal.

**10-2 When SETUP after C2 cannot be changed.**

- (1) Although all the contents of SETUP can be checked in the RUN mode, the  key input except for the C1 key lock is not accepted, and setting change cannot be done. To change the SETUP items, it is necessary to set the instrument to the READY mode.
- (2) When the key lock (C1) is applied (C = 1, 2, 3, or 4), the indications after C2 cannot be checked. After releasing the key lock (C1 = 0), perform setting change.

**10-3 When RUN/READY cannot be selected by key operation.**

The RUN/READY selection function has been assigned to a remote switch. Turn on (closed) the relevant remote switch, and set the READY mode, and then release the assigned SETUP item from the remote switch. The relevant RSW number can be identified by checking the contents of SETUP ("1" is assigned in any of C42 to C53).

**10-4 When the control output is not obtained normally.**

- (1) When the output is a fixed value and not changed, or is not obtained at all.  
Check whether or not any of the following modes is set.
  - READY mode
  - MANUAL mode
  - Fixed value output 1 to 3
- (2) When the output is difficult to change or is not changed beyond a certain value.  
Check the following items.
  - Control output variation limit (PARA 10, 11)
  - PID values (including OL, OH)
  - Variable gain (PARA 49 to 58)

**10-5 When the computer backup function is not activated normally.**

- (1) The output is kept delivered.  
Check the high/low limit scaling (C13, C14) of AI2.  
Set 0.0 in C13 and 100.0 in C14.
- (2) When the RSW, to which the computer backup selection is assigned, is turned on/off, the computer backup is not selected.  
Set "1" in C75 (RSP, C/B selection).

### 10-6 When the motor cannot be adjusted.

The connection methods between the motor and controller are classified into two types as shown below; [direct direction connection] and [reverse direction connection]. The YH digital controllers including the SDC40A are designed to permit the direction (direct/reverse) of the control action to be changed over. Therefore, when the connection with the motor is in the [direct direction], the instrument can cope with the control actions in both directions by simple viewing method. It is recommended to connect the motor in the [direct direction]. This also facilitates troubleshooting if a trouble should occur.

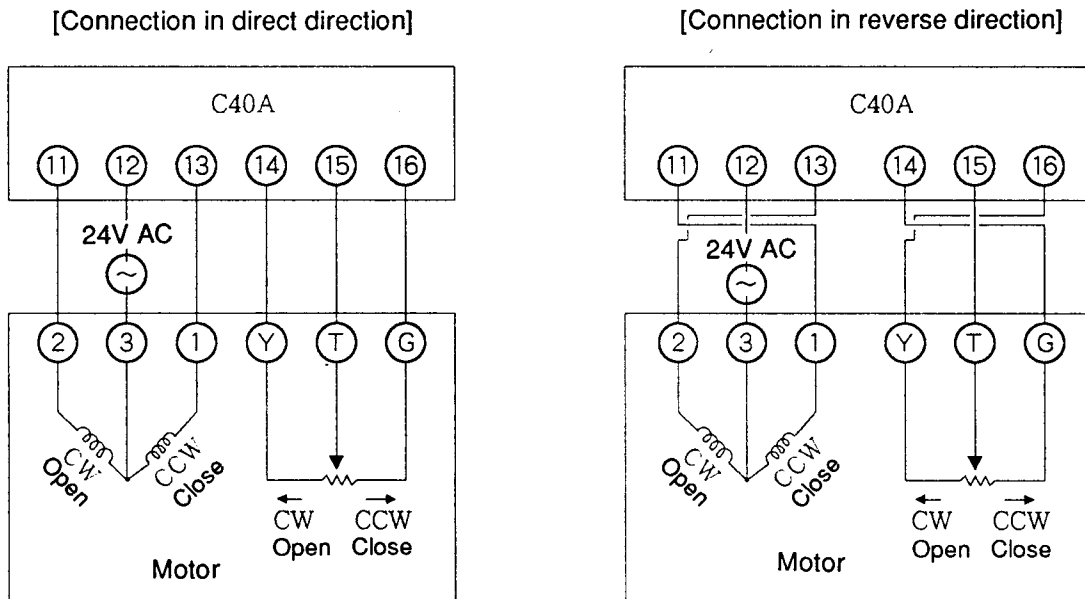

CW : ClockWise (Means rightward turning like the hand of a clock.)  
 CCW : CounterClockWise (Means leftward turning.)

The SDC40A is provided with the functions of detecting misconnection with the motor, and of disconnection or short circuit of MFB (AL10 to 12). However, the connection in reverse direction is regarded as [normal connection] as in the connection in direct direction, and no alarm is then issued.

When the set value of PARA No. 40 is kept at "0" set at delivery from the factory, the operation is kept continued even if MFB is disconnected. The following table lists what phenomena occur according to the connection, when the motor is automatically adjusted (PARA No. 41). The SDC40A start with that the control action setting (C2 or C3) is the reverse action, and the motor is at the closed position (fully counterclockwise). In this table, the numerics in No. 2 indicator are reference values (examples). An alarm is indicated after the motor is fully closed or fully opened.

**[ In case of normal connection in direct direction ]**

No.1 indicator	Lighting LED	No.2 indicator	Motor movement	Remarks
CA.CL	OT2	Stabilized after decreased as 1000 → 500.	CCW	When the motor is turned counter-clockwise with OT2 lighted, the terminals 1 and 2 of the motor are connected in the direct direction.
↓ CA.OP	OT1	Stabilized after increased as 500 → 9500.	CW	

**[ In case of normal connection in reverse direction ]**

No.1 indicator	Lighting LED	No.2 indicator	Motor movement	Remarks
CA.CL	OT2	Stabilized after decreased as 9000 → 500.	CW	1 ↔ 2 reverse and G ↔ Y reverse. When the motor is turned clockwise with OT2 lighted, the terminals 1 and 2 of the motor are connected in the reverse direction.
↓ CA.OP	OT1	Stabilized after increased as 500 → 9500.	CCW	

**[ Indications and causes of misconnection alarm ]**

No.1 indicator	Lighting LED	No.2 indicator	Motor movement	Alarm indication	Cause
CA.CL	OT2	Stabilized after increased.	CCW	AL12	G ↔ Y reverse
↓ CA.OP	OT1	Stabilized after decreased.	CW		
CA.CL	OT2	Stabilized after decreased.	CCW	AL12	T ↔ G reverse
↓ CA.OP	OT1	Stabilized at 15000	CW		
CA.CL	OT2	Stabilized at 15000	CCW	AL11 AL12	T ↔ Y reverse
CA.CL	OT2	Stabilized after increased.	CW	AL12	1 ↔ 2 reverse
↓ CA.OP	OT1	Stabilized after decreased.	CCW		
CA.CL	OT2	Stabilized at 15000	CW	AL11 AL12	1 ↔ 2 reverse and T ↔ G reverse
CA.CL	OT2	Stabilized after increased.	CW	AL12	1 ↔ 2 reverse and T ↔ Y reverse
↓ CA.OP	OT1	Stabilized after 15000	CCW		

## Chapter 11 SPECIFICATION

<b>Analog Input 1 (PV1 input)</b>	<b>Type of inputs</b>	A variety of thermocouples, RTDs, mV and mA.
	<b>Input display accuracy</b>	±0.1% FS (under standard conditions) This may be affected by indication value conversion.
	<b>Input sampling cycle</b>	100ms
	<b>Input digital filter</b>	Variable 0.0 to 120.0s (there is no filter at 0.0)
	<b>Input bias</b>	-1000 to +1000U (U: °C, KPa, % and other standard industrial units)
	<b>Input ratio</b>	0.001 to 9.999
	<b>Input broken line approximation</b>	12 point broken line approximation can be assigned to analog inputs 1 or 2.
	<b>Square root operation dropout</b>	0.0 to 10.0% FS (no square root calculation is performed at 0.0)
	<b>Input bias current</b>	Thermocouple, DC voltage input: ±1.3µA max. (peak, standard conditions) -3µA max. in the linear V range above 1V
	<b>Input impedance</b>	DC current input: 50Ω ±10% (under operating conditions)
	<b>Measuring current</b>	RTD input: 1.04mA±0.02mA, terminal A (under operating conditions)
	<b>Influence of wiring resistance</b>	Thermocouple: Variation in the displayed value due to input µV conversion when the wiring resistance at both ends is 250Ω : <ul style="list-style-type: none"> <li>• M01, L02; 35µV max.</li> <li>• L01; 60µV max.</li> <li>• Others; 750µV max.</li> </ul> RTD: ±0.01% FS/Ω max. within wiring resistance range of 0 to 10Ω. ±0.02% FS/Ω in the range whose minimum resolution is 0.01°C. The allowable wiring resistance is 85Ω max. (except for 0.01°C resolution) (A zener barrier is available for on site adjustment.)
	<b>Allowable parallel resistance</b>	Allowable parallel resistance for thermocouple break detection is 1MΩ min.
<b>Maximum allowable input</b>	Thermocouple, mV input: +15 to -5V mA input: 28mA	

<b>Analog Input 1 (PV1 input)</b>	<b>Burnout</b>	Thermocouple input: Upscale + Alarm indication (AL01) (including the DC mV range) DC voltage input: Downscale + Alarm indication (AL02) DC current input: Downscale + Alarm indication (AL02) However, near 0% FS in the 0 to 20mA range, neither burnout nor alarm indication is performed. RTD input: When 'C' wire is broken: Upscale + Alarm indication (AL01 + AL09) When resistance element and 'A' wire, or resistance element and 'B' wire, or 'A' wire and 'B' wire are broken: Upscale + Alarm indication (AL01 + AL07) When 'B' wire, or resistance element and 'C' wire, or 'A' wire and 'C' wire, or 'B' wire and 'C' wire, or resistance element, 'B' wire and 'C' wire, or 'A' wire, 'B' wire and 'C' wire are broken: Upscale + Alarm indication (AL01 + AL08)
	<b>Over range detection threshold</b>	Higher than 110% FS: Upscale Lower than -10% FS: Downscale (however, downscaling is not performed by F50 and P50 models. The lower indication limit of the B19 model is 20°C/60°F)
	<b>Cold junction compensation accuracy</b>	±0.5°C (standard conditions)
	<b>Cold junction compensation method</b>	Compensation inside the instrument or compensation outside the instrument (0°C only) is selectable.
<b>Analog Input 2</b> (RSP input of remote SP model or PV2 input of internal cascade model)	<b>Type of input</b>	4 to 20mA or 1 to 5V dc
	<b>Input indication accuracy</b>	±0.1% FS (standard conditions), when converted to displayed value (may differ, depending on range)
	<b>Input sampling cycle</b>	0.1s
	<b>Input digital filter</b>	Variable 0.0 to 120.0s (there is no filter at 0.0)
	<b>Input bias</b>	-19999 to +30000U
	<b>Input ratio</b>	0.001 to 30.000 (gain cannot be used in case of selection of the multi ratio of 8 groups. Trade off.)
	<b>Input broken line approximation</b>	12 broken lines of approximation (which can be assigned to either of analog inputs 1 or 2.)
	<b>Square root operation threshold</b>	0.0 to 10.0% FS (no square root calculation is performed at 0.0.)
	<b>Scaling</b>	-19999 to +26000U (reverse scaling is also possible. The decimal point position can be changed. Resolution is 1/20000.)
	<b>Input bias current</b>	1 to 5V input: ±10µA max. (under operating conditions)
	<b>Input impedance</b>	1 to 5V input: 1MΩ min. (under operating conditions) 4 to 20mA input: 50Ω ±10% (under operating conditions)
	<b>Allowable maximum input</b>	1 to 5V input: +6V to 0V 4 to 20mA input: 28mA
	<b>Burnout</b>	Downscale + Alarm indication (AL04)
	<b>Over range detection threshold</b>	More than 110% FS: Regarded as upscale. Less than -10% FS: Regarded as downscale.
<b>PV1 ↔ PV2 switch</b>	Internally switchable in the internal cascade model.	
<b>Indications and Setting</b>	<b>PV and SP indication</b>	5-digit 7-segment LED
	<b>Function indication</b>	2-digit 7-segment LED
	<b>LED bar</b>	Ten LED segments out of twelve indicate control output: • When motor opening indication (2G) is selected, ten segments are used. • When the OK indicator function is selected, all twelve segments are used as a 'green belt'. • This LED bar can also be used to monitor events 4 to 8 and RSW 1 to 12.
	<b>Status indication</b>	18 LEDs (some models do not include all indicators)
	<b>Operating keypad</b>	13 rubber keys (there may be dead keys depending on model).
	<b>Number of set points</b>	1 to 8 points (selection and changeover use available) with the internal cascade model, up to 6 points are allowed on the master side, up to 2 points are allowed on the slave side.
	<b>Memory storage</b>	Non-volatile semiconductor memory (EEPROM)
	<b>Indication ranges</b>	-10 to +110% FS of range or scaling value (-10% FS is not applicable for F50, P50 and B18 models.)
	<b>Setting range</b>	-19999 to +26000U (when an SP limit is applied, the relevant value is used.)
<b>Indication masking</b>	The least significant digit can be masked for 4-digit indication.	

Indications and Setting	SP limits	Low limit: -19999U to high limit value High limit: Low limit value to 26000U																						
	SP ramp (separately set for LSP and RSP)	Up ramp: 0 to 26000U (no ramp at 0) Down ramp: 0 to 26000U (no ramp at 0) The measurement interval can be selected from among the following: • U/hr • 0.1U/hr • U/min • 0.1U/min																						
Control Output	Model number	0D	2G	5G	6D	3D, AK, 5K, 9K, BK																		
	Type of output	SPDT relay contact output	M/M driving relay contact output	Current output (4 to 20mA dc)	Voltage output (load current is adjustable)	* See Table 1.																		
	Control action	Time proportional PID	Position proportional PID	Current proportional PID	Time proportional PID	2-stage (heat/cool) PID																		
	No. of PID groups	8 groups	8 groups	8 groups	8 groups	4 groups on each of heat and cool sides																		
	PID autotuning	Autotuning allowed.	Autotuning allowed.	Autotuning allowed.	Autotuning allowed.	Autotuning not allowed.																		
	Output rating	Contact rating: 5A (30V dc/120V ac, resistive load) 4A (240V dc, resistive load) Allowable contact voltage: 250V ac, resistive load 125V dc, resistive load Maximum switching power: 150W, 960VA (resistive load) Mechanical life: 10,000,000 repetitions Electrical life: 100,000 repetitions (at contact rating, COS $\phi$ = 1, frequency 30 times/min) Minimum switching voltage: 5V Minimum switching current: 100mA Minimum on/off time: 100ms on, on/off control 100ms on, time proportional control	Contact ratings: 2.5A (30V dc L/R = 0.7ms) 4A (120V ac COS $\phi$ = 0.4) 2A (240V ac COS $\phi$ = 0.4) Allowable contact voltage: 250V ac, resistive load 125V dc, resistive load 125V dc L/R = 0.7ms 250V ac COS $\phi$ = 0.4 Maximum switching power: 75W (L/R = 0.7ms) 480VA (COS $\phi$ = 0.4) Mechanical life: 10,000,000 repetitions Electrical life: 100,000 repetitions (at contact rating, COS $\phi$ = 0.4, frequency 30 times/min) Minimum switching voltage: 5V Minimum switching current: 100mA	Max. allowable load resistance: 680 $\Omega$ (under operating conditions) Output accuracy: $\pm$ 0.1% FS max. (under operating conditions) Output resolution: 1/2000min Inrush current: 25mA max., 50ms max. (with 250 $\Omega$ load) Maximum output current: 21.6mA DC Minimum output current: 2.4mA DC Opening terminal voltage: 25V max. Output update cycle: 100ms	Max. allowable load internal resistance: 680 $\Omega$ (under operating conditions) Load current setting accuracy: $\pm$ 0.2% FS max. (under operating conditions) Load current setting resolution: 1/200min Inrush current: 25mA max. 50ms max. (with 250 $\Omega$ load) Maximum output current: 21.6mA dc Minimum output current: 2.4mA dc Off time leak current: 100 $\mu$ A max. (with load is shorted under operating conditions) Output update cycle: 100ms Minimum on-off time: 100ms on, on-off control 100ms on, time proportional control (cycle time: 10s min.) 0.1% of cycle time (cycle time: less than 10 sec.)	Table 1 <table border="1"> <thead> <tr> <th></th> <th>Heat side</th> <th>Cool side</th> </tr> </thead> <tbody> <tr> <td>3D</td> <td>0D</td> <td>0D</td> </tr> <tr> <td>AK</td> <td>0D</td> <td>5G</td> </tr> <tr> <td>5K</td> <td>5G</td> <td>5G</td> </tr> <tr> <td>9K</td> <td>0D</td> <td>6D</td> </tr> <tr> <td>BK</td> <td>5G</td> <td>6D</td> </tr> </tbody> </table> <p>In the heat/cool model, the output type differs between the heat side and cool side as shown in the above table. Each output rating is the same as for 0D, 2G, 5G, or 6D.</p> <ul style="list-style-type: none"> <li>The heat side and cool side can be switched.</li> <li>Direct or reverse action can be selected by remote switching, as in the other models.</li> </ul>		Heat side	Cool side	3D	0D	0D	AK	0D	5G	5K	5G	5G	9K	0D	6D	BK	5G	6D
		Heat side	Cool side																					
	3D	0D	0D																					
	AK	0D	5G																					
	5K	5G	5G																					
	9K	0D	6D																					
	BK	5G	6D																					
Proportional band (P)	0.0 to 1000.0% FS (On-off operation when P=0)	0.1 to 1000.0% FS (On-off operation is not allowed)	0.1 to 1000.0% FS (On-off operation is not possible)	0.0 to 1000.0% FS (On-off operation when P=0)	0.1 to 1000.0% FS (On-off operation is not allowed)																			
Cycle time	5 to 120 s (setting possible every second)	—	—	1 to 60 sec. (setting possible every second)	Same as for each type of output																			
Integral time (I)	0 to 3600 s (PD action when I=0)	0 to 3600 s (PD action when I=0)	0 to 3600 s (PD action when I=0)	0 to 3600 s (PD action when I=0)	0 to 3600 s (PD action when I=0)																			
Derivative time (D)	0 to 1200 s (PI action when D=0)	0 to 1200 s (PI action when D=0)	0 to 1200 s (PI action when D=0)	0 to 1200 s (PI action when D=0)	0 to 1200 s (PI action when D=0)																			
Differential gap	0 to 1000U (in on-off operation)	—	0 to 1000U (in on-off operation)	0 to 1000U (in on-off operation)	Same as in each output type.																			
Dead band	—	0.5 to 25.0% OUT	—	—	-100.0 to +5.0% OUT																			
Output limiter	Low limit value: -10% to high limit value (-10 to 0% become 0%) High limit value: Low limit value to 110% (100 to 110% become 100%)	Low limit value: -10% to high limit value High limit value: Low limit value to 110%	Low limit value: -10% to high limit value High limit value: Low limit value to 110%	Low limit value: -10% to high limit value (-10 to 0% become 0%) High limit value: Low limit value to 110% (100 to 110% become 100%)	Low limit value: -10% to high limit value High limit value: Low limit value to 110%																			

<b>Control Output</b>	<b>Model number</b>	0D	2G	5G	6D	3D, AK, 5K, 9K, BK
	<b>Manipulated variable change rate limiter</b>	1 to 100% (every 100 ms)	1 to 100% (every 100 ms)	1 to 100% (every 100 ms)	1 to 100% (every 100 ms)	1 to 100% (every 100 ms)
	<b>MFB (Motor Feed back) input range</b>	---	100 to 2500Ω	---	---	---
	<b>MFB (Motor Feed back) break control</b>	---	Whether action is to be continued is selected by MFB position assumption.	---	---	---
	<b>Variable gain</b>	<p>If the load characteristic of the control system is non-linear, stable control characteristics are obtained by changing the gain according to the deviation. Control conforms to the following equation:  Set proportional band (p) <math>\times \frac{1}{\text{Gain value}} = \text{Real proportional band.}</math>  Set value range: 0.01 to 300.00  Gain 1: when +20% FS  Gain 2: when +10% FS  Gain 3: when +5% FS  Gain 4: when +2% FS  Gain 5: when 0% FS  Gain 6: when -2% FS  Gain 7: when -5% FS  Gain 8: when -10% FS  Gain 9: when -20% FS</p> <p>The gain ramp is automatically calculated using set gains. When the deviation is less than -20% or more than 20%, calculation uses the extended characteristic.</p>				
<b>Remote Switch Input (RSW)</b>	<b>No. of input points</b>	4 or 12 (option)				
	<b>Connectable outputs</b>	Dry contact (relay contact) and open collector (current sink to ground)				
	<b>Opening terminal voltage</b>	12V + 0.6/-1.6V between common terminal (No. 25) and each input terminal (under operating conditions)				
	<b>Shorting terminal current</b>	The current from each terminal is 6mA +0.6/-1.0mA (under operating conditions)				
	<b>Allowable contact resistance (dry contact)</b>	On: Less than 700Ω (under operating conditions) Off: More than 10kΩ (under operating conditions)				
	<b>Residual voltage at open collector on time</b>	3V max. (under operating conditions)				
	<b>Leak current at open collector off time</b>	100μA max. (under operating conditions)				
	<b>Parallel connection with other instrument</b>	Interconnection of SDC 40A units is possible. Connection with compatible units other than SDC 40A is also allowed.				
	<b>Input sampling cycle</b>	0.1 s				
	<b>Minimum hold time of on detection</b>	0.2 s				
	<b>Function allocation</b>	<p>NOP, RUN/READY, AUTO/MANUAL, REMOTE/LOCAL, AT start/stop, direct/reverse action, LSP number and PID number selection 0/+1, 0/+2, and 0/+4 (PID No. 0 cannot be selected)  Fixed MV value output 1, 2 and 3  LSP shift 0/+1, 0/+2, 0/+4, 0/+8, 0/+16, 0/+32, 0/+64, 0/+128, 0/+256, 0/+512  Analog input 2 ratio number selection 0/+1, 0/+2, 0/4  Computer backup system 1 and 2</p> <div style="display: flex; justify-content: space-around;"> <div style="text-align: center;"> <p><u>How to use LSP number / LSP shift</u></p> <p>Set by configuration C55 (-10000 to +10000U)</p> </div> <div style="text-align: center;"> <p><u>Computer backup system usage</u></p> <div style="display: flex; justify-content: space-around;"> <div style="text-align: center;"> <p><u>Normal operations</u></p> <p>The control output is used directly.</p> </div> <div style="text-align: center;"> <p><u>On computer error</u></p> </div> </div> <p>The output is changed over by remote switch input to control by SDC 40A. One of the following two configurations must then be selected by the remote switch:  ① PV at changeover is used as SP.  ② LSP preset is used as SP.</p> </div> </div>				

No. of output points	2 points: standard (SPST relay contact). 1 point (SPDT relay contact) and 5 points (open collector output) can optionally be added.				
<b>Event setting</b>	Direct PV	Reverse PV	Direct deviation	Reverse deviation	Direct absolute deviation value
	Reverse absolute deviation value	Direct MV	Reverse MV	Direct RSP	Reverse RSP
	Direct SP	Reverse SP	Direct motor feedback	Reverse motor feedback	All alarm sum
	PV range alarm	Instrument alarm	Manual status	READY status	Local status
	Auto tuning status	Process diagnosis *	<p><b>* Process diagnosis event:</b> This is turned ON if the event on delay time is exceeded, but the temperature does not rise beyond the differential gap (does not lower in the case of direct action) when the manipulated variable is larger than the event set output value.</p>		
<b>Setting range</b>	PV (direct, reverse): -19999 to +26000U Deviation (direct, reverse): -19999 to +26000U Absolute deviation value: 0 to 26000U MV (direct, reverse): -10.0 to +110.0%		RSP (direct, reverse): -19999 to +26000U MFB (direct, reverse): -10.0 to +110.0% Process diagnostics: -10.0 to +110.0%		
<b>Differential gap (hysteresis) setting range</b>	MV event, other than MFB: 0 to 200U, MV event, MFB: 0.0 to 20.0% However, when alarm event or status alarm is set, no differential gap can be set.				
<b>On delay time</b>	0 to 20000s or 0 to 20000 min. The on delay time can be set for event output EV1 to EV3.				
<b>Output action</b>	On-off				

Event	Output rating	Item	EV <sub>1</sub> , EV <sub>2</sub> (standard)	EV <sub>3</sub> (option)	EV <sub>4</sub> to E <sub>8</sub> (option)
		Type of output	SPST (1a) relay contact	SPDT (1a1b) relay contact	Open collector output
Contact rating	1A (30V dc/250V ac with resistive load)	2A (30V dc/250V ac with resistive load)	—		
Allowable contact voltage	250V ac with resistive load 30V dc with resistive load	250V ac with resistive load 30V dc with resistive load	—		
Mechanical life	20,000,000 cycles	50,000,000 cycles	—		
Electrical life	100,000 cycles (at contact rating, and frequency of 20 times/min.), COS $\phi = 1$	100,000 cycles (at contact rating, and frequency of 20 times/min.), COS $\phi = 1$	—		
Minimum on-off voltage	10V	10V	—		
Minimum on-off current	10mA (Use a bleeder resistor if necessary.)	10mA (Use a bleeder resistor if necessary.)	—		
Load drive power voltage range	—	—	—	10V dc to 29V dc	
Maximum output current	—	—	—	70mA/point max. (under operating conditions)	
Off time leak current	—	—	—	0.1mA/point max. (under operating conditions, within load drive power voltage range)	
Off time residual voltage	—	—	—	1.6V max. (under operating conditions, within load drive power voltage range, and at maximum output current)	
Auxiliary output	No. of output points	1 or 2 (1 point in 2G, 3D, AK, 5K, 9K, and BK models)			
	Type of output	Selectable from PV, SP, DEV, RSP, MV and MFB.			
	Output rating	4 to 20mA dc. Max. allowable load resistance: 680 $\Omega$			
	Output accuracy	$\pm 0.1\%$ FS (under standard conditions)			
	Output resolution	1/2000 (numeric value of independent resolution; for example, the input resolution of PV or MFB is not included)			
	Inrush current	25mA max. 50ms max. (with 250 $\Omega$ load)			
	Maximum output current	21.6mA			
	Minimum output current	2.4mA			
	Opening terminal voltage	25V max.			
	Output update cycle	0.1s			
Communication	Communication system	Communication protocols	RS-485 (Note 1)		RS-232C
		Network	Multidrop The device is provided only with the slave station function. 1 to 16 units max. (DIM), 1 to 31 units max. (CMA, SCM).	The device is provided only with the slave station function.	
		Data flow	Half duplex		Half duplex
		Synchronization	Start/stop synchronization		Start/stop synchronization
	Interface system	Transmission system	Balanced (differential)		Unbalanced
		Data line	Bit serial		Bit serial
		Signal lines	5 transmit/receive lines (3-wire connection is also possible)		3 transmit/receive lines
		Transmission speed	4800, 9600 bps		4800, 9600 bps
		Communication distance	500m max. (total)		15m max.
		Protocol	RS-485		RS-232C
	Message characters	Character configuration	11 bits/character		11 bits/character
		Format	1 start bit, even parity, and 1 stop bit, or 1 start bit, no parity, and 2 stop bits		1 start bit, even parity, and 1 stop bit, or 1 start bit, no parity, and 2 stop bits
		Data length	8 bits		8 bits
	Isolation	Completely isolated between the input and output.			
	Note: 1. For RS-485 communications, the device can be connected not only to computers equipped with RS-485, but also to Yamatake Corporation's MX200, MA500 (DK link II DIM) or CMA50 controllers.				

<b>General specifications</b>	<b>Memory backup</b>	Non-volatile semiconductor memory (EEPROM)				
	<b>Rated power voltage</b>	90 to 264V ac, 50/60Hz				
	<b>Power consumption</b>	25VA max.				
	<b>Power switching inrush current</b>	15A max. 10ms (under operating conditions) Caution: When applying power to a number of SDC 40As simultaneously, ensure sufficient power is supplied, or start up the SDC 40As in series. Otherwise, the controllers may not start up normally due to voltage drop from the inrush current. It is necessary to reach the stable voltage within 2 sec. of power being supplied.				
	<b>Insulation resistance</b>	More than 20MΩ between power terminal 1 or 2 and ground terminal 3 (using 500V dc megger).				
	<b>Dielectric strength</b>	1500V ac, 50/60Hz for 1 min. between power terminal and ground terminal 1500V ac, 50/60Hz for 1 min. between relay output and ground terminal 500V ac, 50/60Hz for 1 min. between any other part and ground terminal 500V ac, 50/60Hz for 1 min. between isolated terminals				
	<b>Standard conditions</b>	Ambient temperature	23±2°C			
		Ambient humidity	60±5% RH			
		Rated power voltage	105V ac ±1%			
		Power frequency	50±1Hz or 60±1Hz			
		Vibration resistance	0m/s <sup>2</sup>			
		Shock resistance	0m/s <sup>2</sup>			
		Mounting angle	Reference plane (vertical) ±3°			
	<b>Operating conditions</b>	Ambient temperature range	0 to 50°C			
		Ambient humidity range	10 to 90% RH (non-condensing)			
		Rated power voltage	90 to 264V ac			
		Power frequency	50±2Hz or 60±2Hz			
		Vibration resistance	0 to 1.96m/s <sup>2</sup>			
		Shock resistance	0 to 9.80 m/s <sup>2</sup>			
Mounting angle		Reference plane (vertical) ±10°				
<b>Transport/storage conditions</b>	Ambient temperature range	-20 to +70°C				
	Ambient humidity range	10 to 95% RH (non-condensing)				
	Vibration resistance	0 to 4.90m/s <sup>2</sup> (10 to 60Hz, for 2hr each in X, Y and Z directions)				
	Shock resistance	0 to 490m/s <sup>2</sup> (3 times in vertical direction)				
	Package drop test	Drop height: 60cm (1 angle, 3 edges, 6 planes, freefall)				
<b>Materials of mask and case</b>	Mask: Multilon Case: Polycarbonate					
<b>Colors of mask and case</b>	Mask: Dark gray (Munsell 5Y3.5/1) Case: Light gray (Munsell 2.5Y7.5/1)					
<b>Mounting</b>	Panel flush type, using the dedicated mounting bracket					
<b>Weight</b>	Approx. 750g (Extension terminal base: Approx. 150g)					
<b>Standard accessories</b>	<b>Name</b>	<b>Model No.</b>	<b>Q'ty</b>	<b>Options</b>	<b>Name</b>	<b>Model No.</b>
	Unit indicating label	N-3132	1		Hard dust-proof cover set	81446083-001
	Mounting bracket	81405411-001	1 set (2 brackets)		Soft dust-proof cover set	81446087-001
	Instruction manual	CP-UM-1580E	1		Terminal cover set	81446084-001



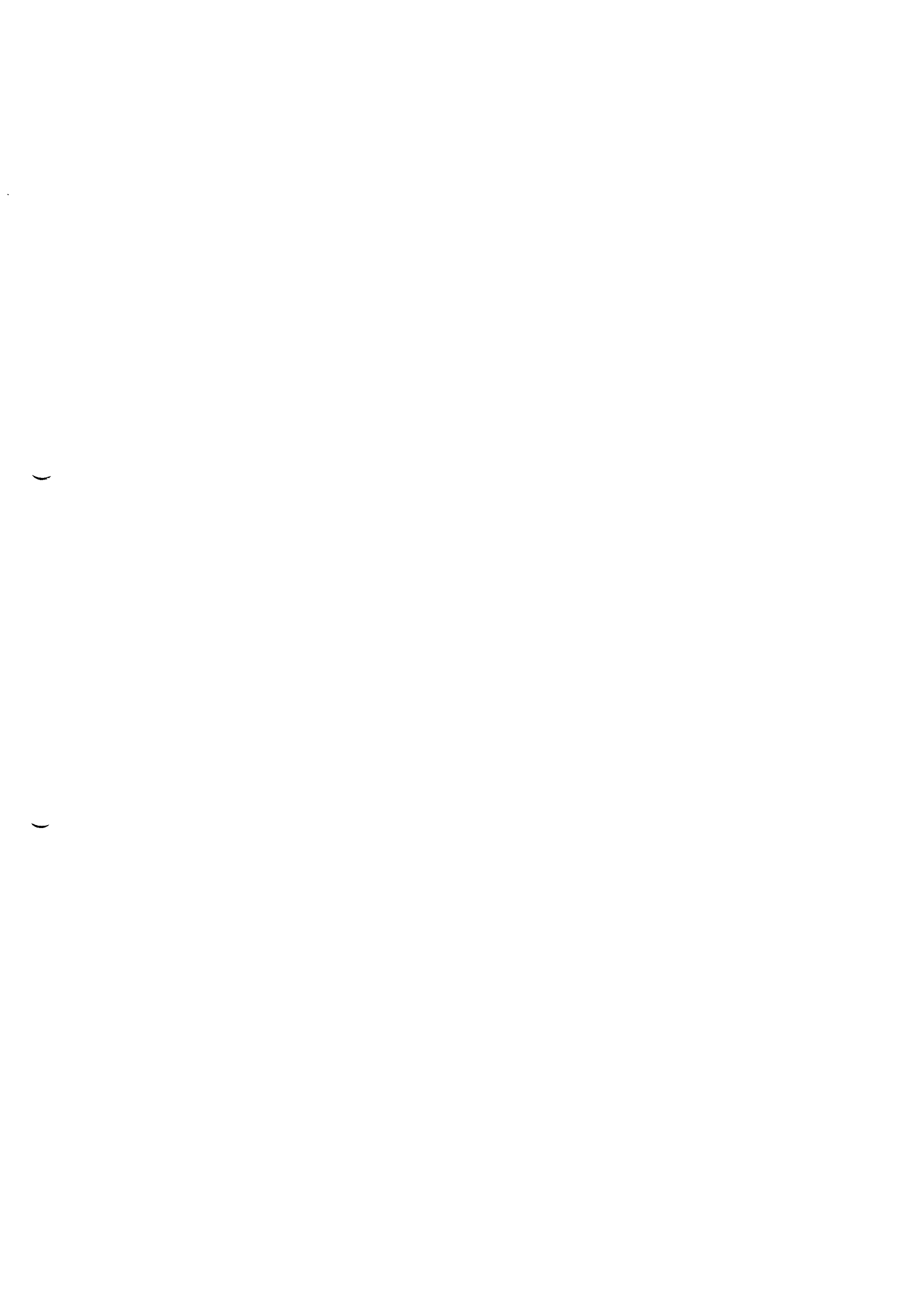

*Specification are subject to change without notice.*

**YAMATAKE**

---

**Yamatake Corporation**

Control Products Division

1-12-2, Kawana

Fujisawa, Kanagawa, 251-8522, Japan

Phone: 81-466-20-2187

Fax: 81-466-20-2309

*This has been printed on recycled paper.*

Printed in Japan.

1st Edition: Issued in June, 1994

3rd Edition: Issued in Apr., 1999 (K)