

# DigitroniK Line SDC40A Digital Indicating Controller User's Manual

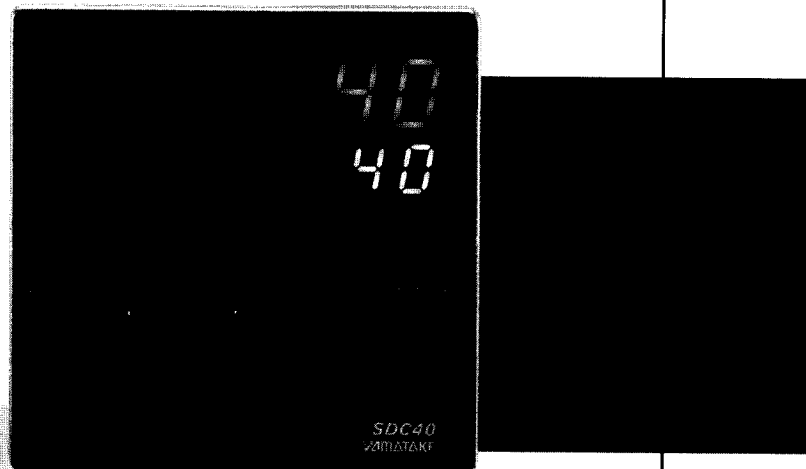

Thank you for purchasing the SDC40A. This manual contains information for ensuring correct use of the the SDC40A. It also provides necessary information for installation, maintenance, and troubleshooting.

This manual should be read by those who design and maintain devices that use the the SDC40A.

Be sure to keep this manual near by for handy reference.

Yamatake Corporation

## **RESTRICTIONS ON USE**

When using this product in applications that require particular safety or when using this product in important facilities, pay attention to the safety of the overall system and equipment. For example, install fail-safe mechanisms, carry out redundancy checks and periodic inspections, and adopt other appropriate safety measures as required.

## **REQUEST**

Make sure that this Instruction Manual is handed over to the user before the product is used.

Copying or duplicating this Instruction Manual in part or in whole is forbidden. The information and specifications in this Instruction Manual are subject to change without notice.

Considerable effort has been made to ensure that this Instruction Manual is free from inaccuracies and omissions.

If you should find any inaccuracies or omissions, please contact Yamatake Corporation.

In no event is Yamatake Corporation liable to anyone for any indirect, special or consequential damages as a result of using this product.

**© 1994 Yamatake Corporation ALL RIGHTS RESERVED**

The above is a trademark of Yamatake Corporation.

# ———— CONTENTS ————

## **Chapter 1 NAMES AND FUNCTIONS OF COMPONENT PARTS**

1-1	Introduction .....	1-1
1-2	Basic Function Block Diagram .....	1-2
1-3	Names and Functions of Indicators on Console .....	1-4
1-4	Names and Functions of Keys on Console .....	1-5
1-5	Model Selection Guide .....	1-6
1-6	Input Types and Range Numbers .....	1-7

## **Chapter 2 INSTALLATION**

2-1	External Dimensions .....	2-1
2-2	Panel Cutout Size .....	2-2
2-3	Mounting .....	2-3

## **Chapter 3 WIRING**

3-1	Cables .....	3-1
3-2	Terminal Connections .....	3-2
3-3	Terminal Arrangement and Recommended Direction of Wire Draw-out .....	3-2
3-4	Power Supply Connections .....	3-3
3-5	Grounding .....	3-3
3-6	Terminal Connection Diagrams of Standard and Extension Terminal Bases .....	3-4
3-7	Input 1 (PV1) Connection .....	3-5
3-8	Input 2 (PV2/RSP) Connection .....	3-5
3-9	Control Output Connection .....	3-6
3-10	Connection of Auxiliary Output 1, 2 (option) .....	3-8
3-11	Connection of Relay Event Output .....	3-8
3-12	Connection of Open Collector Event Output (option) .....	3-9
3-13	Connection of Remote Switch Input (option) .....	3-9
3-14	Communication (option) Connection .....	3-10
3-15	Wiring Precautions .....	3-13

3-16	Noise .....	3-13
	1. Noise generation sources	
	2. Measures for noise suppression	
3-17	Isolation between Input and Output .....	3-14
<b>Chapter 4</b>	<b>OUTLINE OF SETTING</b>	
4-1	Initialize .....	4-1
4-2	Major Setup Items (block diagram) .....	4-1
<b>Chapter 5</b>	<b>SETTING OF PARAMETER (PARA) ITEMS</b>	
5-1	Parameter Operation .....	5-1
5-2	Parameter Item Table .....	5-3
5-3	Detailed Description of Parameter Items .....	5-10
<b>Chapter 6</b>	<b>SETTING OF PID ITEMS</b>	
6-1	PID Operation .....	6-1
6-2	PID Item Table .....	6-3
6-3	Detailed Description of PID Items .....	6-4
<b>Chapter 7</b>	<b>SETTING OF SETUP ITEMS</b>	
7-1	Setup Operation .....	7-1
7-2	Setup Item Table .....	7-3
7-3	Detailed Description of Setup Items .....	7-15
<b>Chapter 8</b>	<b>USER FUNCTION KEYS UF1 AND UF2</b>	
8-1	How to Use the User Function Keys .....	8-1
8-2	How to Register a Function in User Function Key .....	8-2
<b>Chapter 9</b>	<b>OPERATION</b>	
9-1	Power ON .....	9-1
9-2	Indication Changeover .....	9-1
9-3	Setting of SP and SP Number .....	9-5
9-4	EV Setting .....	9-10

**Chapter 10 TROUBLESHOOTING**

10-1 Alarm Indication .....	10-1
10-2 When SETUP after C2 cannot be changed. ....	10-2
10-3 When RUN/READY cannot be selected by key operation. ....	10-2
10-4 When the control output is not obtained normally. ....	10-2
10-5 When the computer backup function is not activated normally. ....	10-2
10-6 When the motor cannot be adjusted. ....	10-3

**Chapter 11 SPECIFICATION**



# Chapter 1 NAMES AND FUNCTIONS OF COMPONENT PARTS

## 1-1 Introduction

The DIGITRONIK SDC40A is a general-purpose indicating controller for controlling the temperature, pressure, flowrate, pH, liquid level and others.

The SDC40A features a wide variety of input options; thermocouples, resistance thermometer bulbs, DC voltage and DC current inputs are supported. Control actions are also provided with such superb functions that not only two-freedom degree PID, but also tuning by neural net and smart tuning for suppressing overshoot can be selected optionally. Therefore, the SDC40A can be used for a variety of applications, making the best of the following features.

### Features

- High accuracy and high resolution : Accuracy of  $\pm 0.1\%$  FS, sampling cycle of 0.1 sec, and high resolution display of 5 digits. Stable high-resolution control actions can be realized.
- Instensified correspondence to PLC : Flexibly corresponds to automatic operation in combination with a PLC, providing a maximum of 12 remote switch inputs and a maximum of 8 event outputs.
- Coping with system down : The instrument cannot only back up a PLC, computer or the like used as a center of automation, but also can cope with system down more quickly with the monitoring functions of sensors or operation terminals strengthened.
- Correspondence to various controls : Flexibly corresponds to various controls of temperature, pressure, flowrate, level, pH and others by the variable gain, input broken line approximation, multi ratio setting, internal cascade functions, and others.
- Simple operation : The operation levels are classified into two; short time setup by the smart handy loader is provided for an engineer, while simple setting by the user function keys is provided for an operator.

### Configuration

This instrument consists of a console, main body, standard terminal base, and extension terminal base (option).

- Console : 7-segment display, LEDs and various operation keys
- Main body : Case and others
- Standard terminal base : Terminals for connecting the power supply, sensors and others.
- Extension terminal base: Terminals for connecting communication signals, event outputs and remote switches used as option.

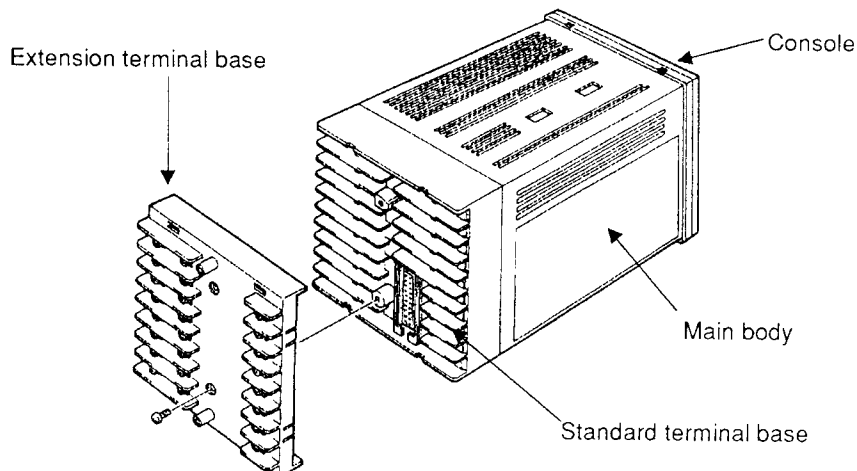

**1-2 Basic Function Block Diagram**

- Standard Model and Remote SP Model (★: Optional function)

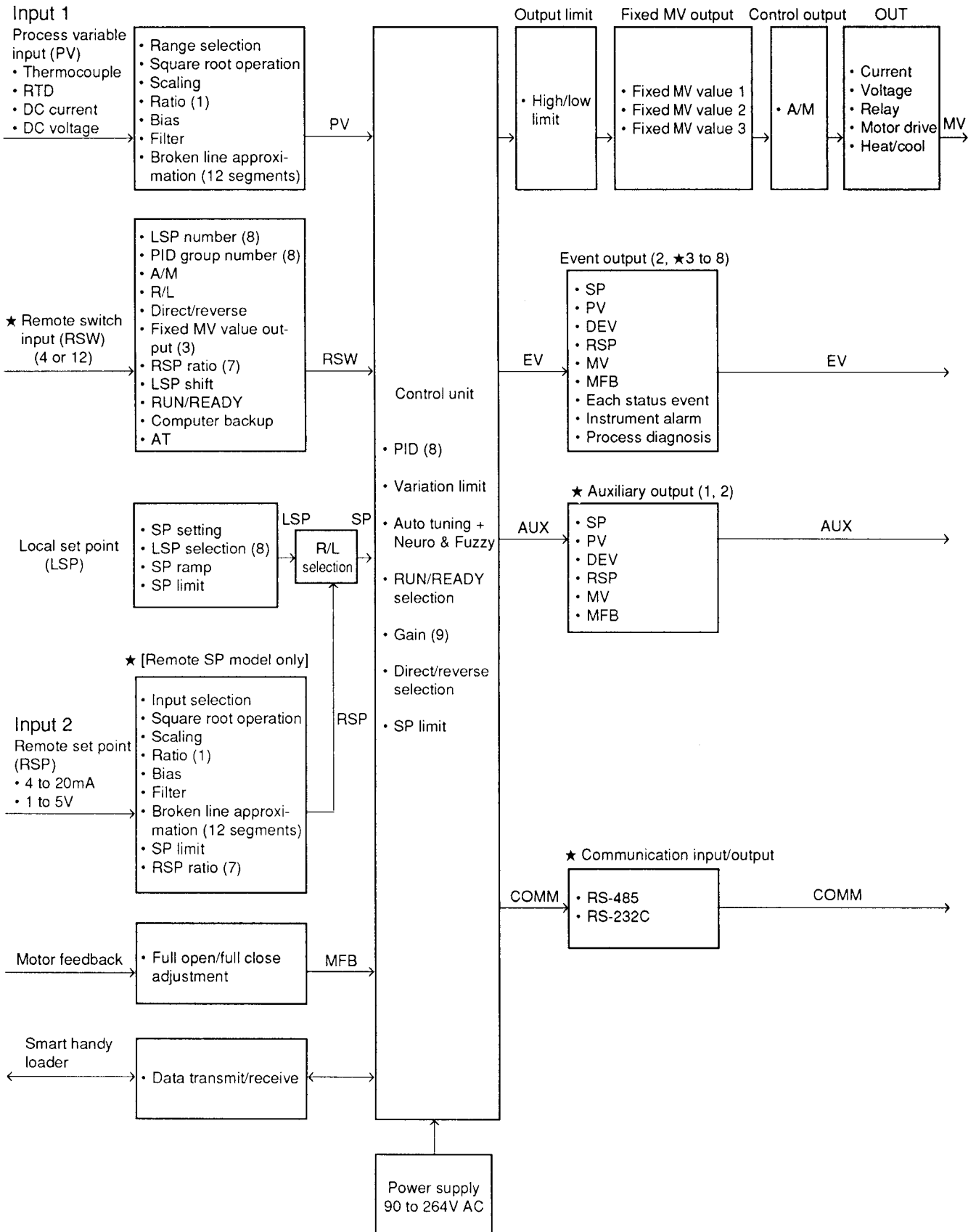

• Internal Cascade Model (★: Optional function)

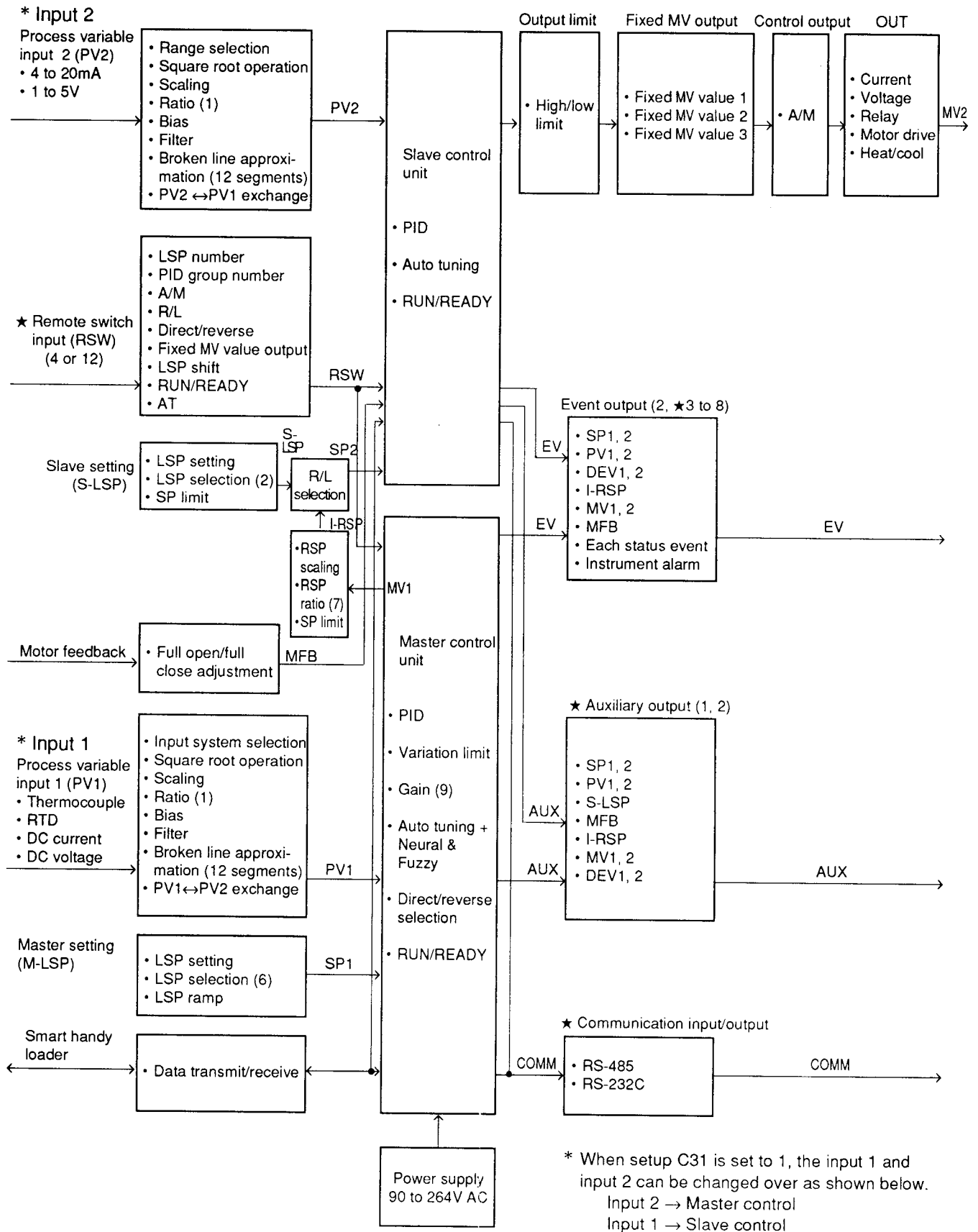

### 1-3 Names and Functions of Indicators on Console

The console consists of keys, indicators and LEDs (light-emitting diode lamps) to permit various operations to be done.

**Channel LED**

Indicates the channel number of a PV being indicated currently. (Lights only in internal cascade model.)  
 CH1 : PV1 of input 1  
 CH2 : PV2 of input 2

**Mode LEDs**

Indicates the operation mode of the instrument.  
**RDY (READY)**  
 : Lights in READY mode, and goes out in RUN mode.  
**REM (REMOTE)**  
 : Lights when remote set input RSP is applied, and goes out when local set input LSP is applied.  
**MAN (MANUAL)**  
 : Lights in manual operation, and goes out in AUTO operation.  
**COM (COMMUNICATION)**  
 : Lights when the communication line is used.

**No.3 indicator**

An auxiliary indicator which indicates the group number of an SP, and can also indicate the item number of a parameter, etc.

**OUT LED**

Lights when a control output value when is indicated in a bar graph.

**EV1, 2, 3**

The relevant LED lights when a relay event output is turned on.

**No.1 indicator**

Indicates a PV value (measured temperature) usually and can also indicate the contents of parameters, etc.

**No.2 indicator**

Indicates an SP (set temperature) and can also indicate the numerics of parameters, etc. or can also indicate a deviation, manipulated variable, etc. selectively.

**Bar graph indicator**

Indicates the control output in percentage as a bar graph facing sideways, and can also be used as a green belt, remote switch monitor or event monitor to indicate a control condition.

**UF (User Function) LED**

LED lamp whose lighting condition can be set by a user.

**AT (Auto Tuning) LED**

Flashes when the instrument is placed in the auto tuning mode, and lights when it is placed in the smart tuning mode.

**OT1, 2 control output status LED**

The relevant LED lights when a control output is turned on.

**No.2 indicator contents LEDs**

Indicates the contents of the value indicated in No. 2 indicator.  
 SP (Set Point) : Lights when the set temperature is indicated.  
 DEV (Deviation) : Lights when a deviation (PV - SP) is indicated.  
 OUT (Output) : Lights when the control output is indicated.

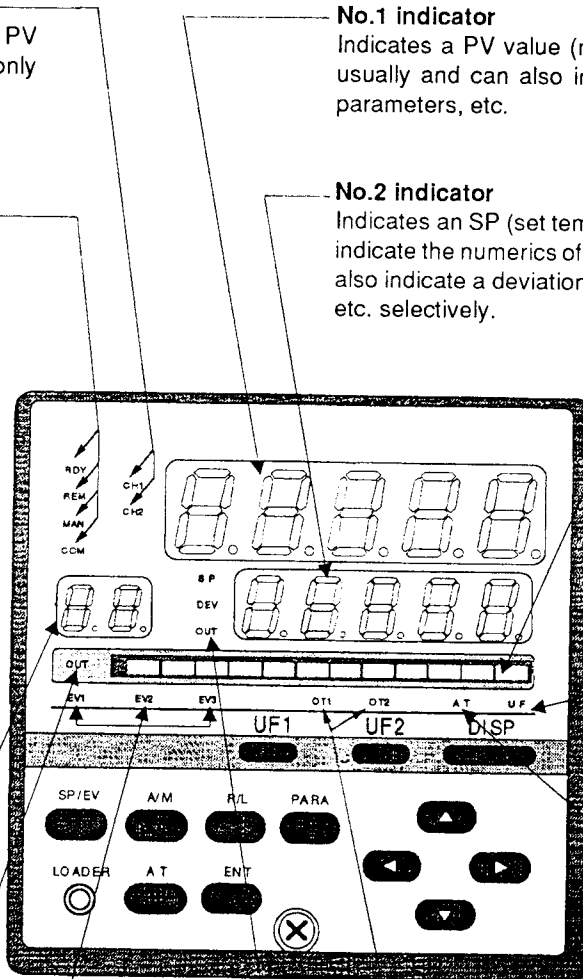

### 1-4 Names and Functions of Keys on Console

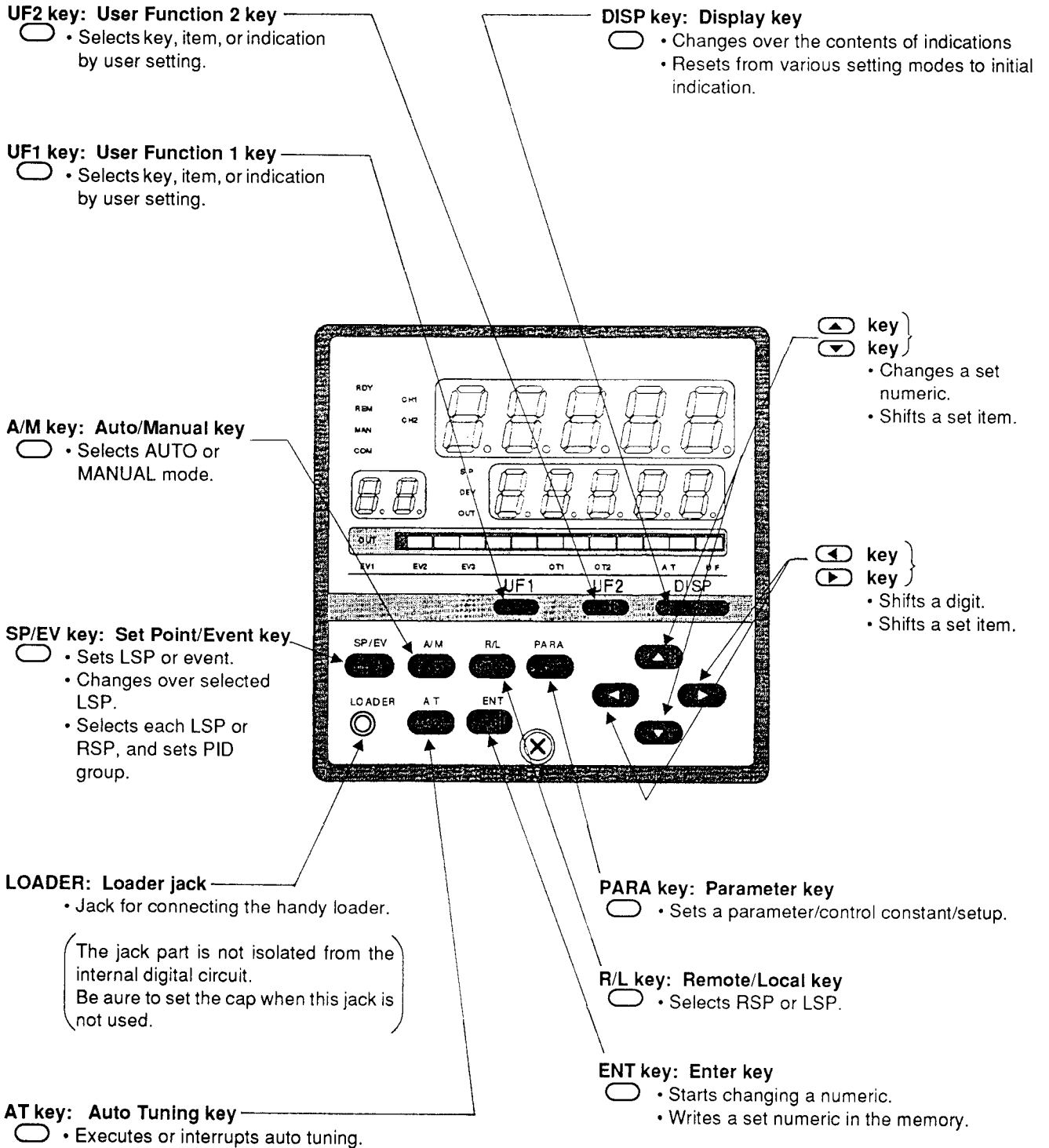

**1-5 Model Selection Guide: Example C40A5G0AS04100**

Basic Model No.	Control output	Function	Power supply	Option 1	Option 2	Additional processing	Description
C40A							Digital indicating controller
	0D						Relay output (on-off or time proportional)
	6D						Voltage output (with current value adjusting function)
	2G						Position proportional output
	5G						Current output (4 to 20mA)
	3D						Heat/cool control, relay output + relay output
	AK						Heat/cool control, relay output + current output
	5K						Heat/cool control, current output + current output
	9K						Heat/cool control, relay output + voltage output
	BK						Heat/cool control, current output + voltage output
		0					Standard model
		1					Remote SP function model
		2					Internal cascade function model
			AS				Free power supply voltage
				00			Option 1 is not provided with (2 points of SPST relay contact output provided).
				01			With 4 points of remote switching
				02			With 1 added point of SPDT relay contact event output
				03			With 4 points of remote switching + 1 added point of SPDT relay contact event output
				04			With 4 points of remote switching + 1 point of auxiliary output
				05			With 1 added point of event output + 1 point of auxiliary output
				06			With 4 points of remote switching + 1 added point of SPDT relay contact event output + 1 point of auxiliary output
				07			With 4 points of remote switching + 2 points of auxiliary output
				08			With 1 added point of event output + 2 points of auxiliary output
				09			With 4 points of remote switching + 1 added point of SPDT relay contact event output + 2 points of auxiliary output
					0		Option 2 is not provided. (If option 1 is not designated, 0 will be selected without fail.)
					1		With 8 added points of remote switching + 5 added points of event output (open collector output)
					2		With 8 added points of remote switching + 5 added points of event output (open collector output) + RS-485 communication
					3		With 8 added points of remote switching + 5 added points of event output (open collector output) + RS-232C communication
					00		Additional processing not provided.
					T0		Tropicalization treatment applied
					K0		Antisulfidation corrosion treatment applied
					D0		Data attached
					B0		Tropicalization treatment applied + data attached
					L0		Antisulfidation corrosion treatment applied + data attached

Option 2 \ Option 1	0	1	2	3
00	○	×	×	×
01	○	○	○	○
02	○	×	×	×
03	○	○	○	○
04	○	○	○	○
05	○	×	×	×
06	○	○	○	○
07	○	○	○	○
08	○	×	×	×
09	○	○	○	○

**Notes:**

The two auxiliary output points of option 1 cannot be specified for the following control outputs. 2G, 3D, AK, 5K, 9K, B

Any of 1 to 3 of option 2 can be selected only when four points of remote switching are provided in option 1 (01, 03, 04, 06, 07, 09).

Selection guide table  
 ○ : Combination possible.  
 × : Combination not possible.

**Note:**

If any of 1 to 3 of option 2 are selected, the extension terminal base is provided.

## 1-6 Input Types and Range Numbers

Input typ	Range number	Code	°C range (°C)	°F range (°F)
K (CA)	0	K09	0.0 to 1200.0	0 to 2400
K (CA)	1	K08	0.0 to 800.0	0 to 1600
K (CA)	2	K04	0.0 to 400.0	0 to 750
K (CA)	3	K29	-200.0 to +1200.0	-300 to +2400
K (CA)	4	K44	-200.0 to +300.0	-300 to +700
K (CA)	5	K46	-200.0 to +200.0	-200 to +400
E (CRC)	6	E08	0.0 to 800.0	0 to 1800
J (IC)	7	J08	0.0 to 800.0	0 to 1600
T (CC)	8	T44	-200.0 to +300.0	-300 to +700
B (PR30-6)	9	B18	0.0 to 1800.0	0 to 3300
R (PR13)	10	R16	0.0 to 1600.0	0 to 3100
S (PR10)	11	S16	0.0 to 1600.0	0 to 3100
W (WRe5-26)	12	W23	0.0 to 2300.0	0 to 4200
W (WRe5-26)	13	W14	0.0 to 1400.0	0 to 2552
PR40-20	14	D19	0.0 to 1900.0	0 to 3400
Ni-Ni · Mo	15	Z13	0.0 to 1300.0	32 to 2372
N	16	U13	0.0 to 1300.0	32 to 2372
PL II	17	Y13	0.0 to 1300.0	32 to 2372
DIN U	18	Z08	-200.0 to +400.0	-300 to +750
DIN L	19	Z07	-200.0 to +800.0	-300 to +1600
Gold iron-chromel	20	Z06	0.0 to 300.0 K	——

Input typ	Range number	Code	°C range (°C)	°F range (°F)
JIS '89 Pt100 (IEC Pt100Ω)	32	F50	-200.0 to +500.0	-300.0 to +900.0
	33	F46	-200.0 to +200.0	-300.0 to +400.0
	34	F32	-100.0 to +150.0	-150.0 to +300.0
	35	F36	-50.0 to +200.0	-50.0 to +400.0
	36	F38	-60.00 to +40.00	-76.00 to +104.00
	37	F33	-40.00 to +60.00	-40.00 to +140.00
	38	F05	0.0 to 500.0	0.0 to 900.0
	39	F03	0.0 to 300.0	0.0 to 500.0
	40	F01	0.00 to 100.00	0.00 to 200.00
JIS '89 JPt100	48	P50	-200.0 to +500.0	-300.0 to +900.0
	49	P46	-200.0 to +200.0	-300.0 to +400.0
	50	P32	-100.0 to +150.0	-150.0 to +300.0
	51	P36	-50.0 to +200.0	-50.0 to +400.0
	52	P38	-60.00 to +40.00	-76.00 to +104.00
	53	P33	-40.00 to +60.00	-40.00 to +140.00
	54	P05	0.0 to 500.0	0.0 to 900.0
	55	P03	0.0 to 300.0	0.0 to 500.0
	56	P01	0.00 to 100.00	0.00 to 200.00

Input typ	Range number	Code	Range (programmable)
4 to 20mA	64	C01	-19999 to 26000
0 to 20mA	65	C08	
0 to 10mV	66	M01	
-10 to 10mV	67	L02	
0 to 100mV	68	L01	
0 to 1V	69	L04	
-1 to 1V	70	L08	
1 to 5V	71	V01	
0 to 5V	72	L05	
0 to 10V	73	L07	

# Chapter 2 INSTALLATION

## 2-1 External Dimensions

Unit: mm

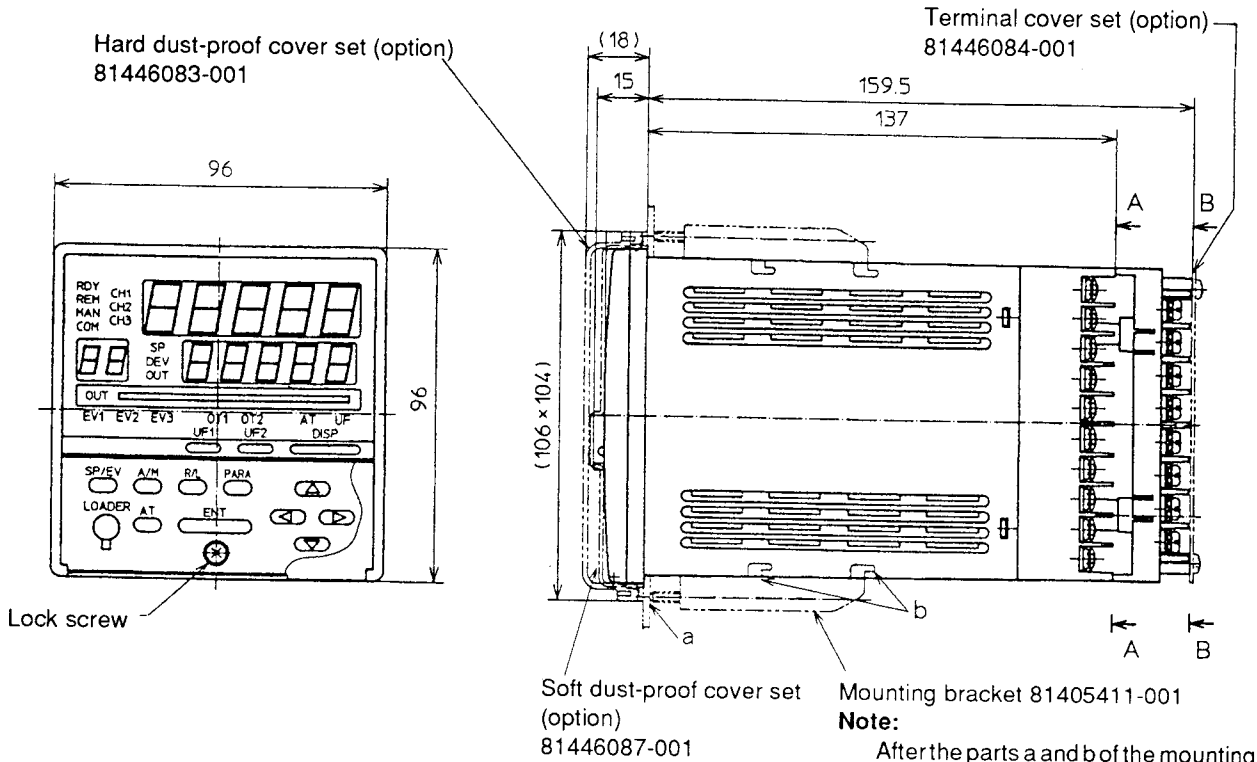

**Note:**  
 After the parts a and b of the mounting bracket touch the mates, tighten the screws by one turn only.  
 Note that the case may be deformed by tightening the screws excessively.  
 Also install the instrument prior to the lower mounting brackets.

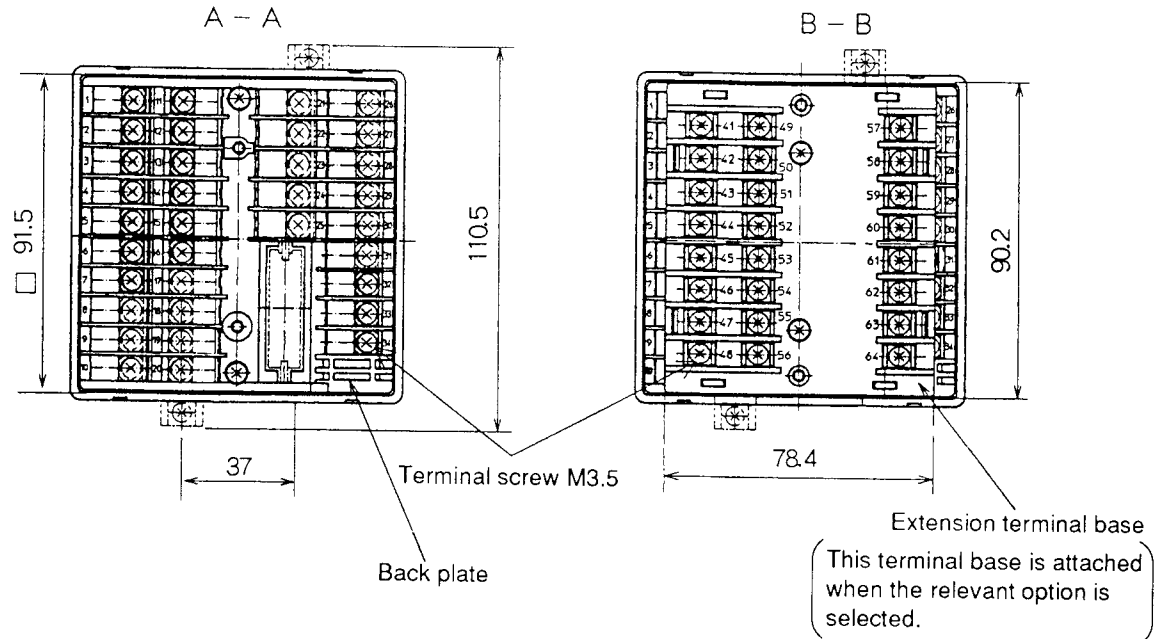

## 2-2 Panel Cutout Size

Unit: mm

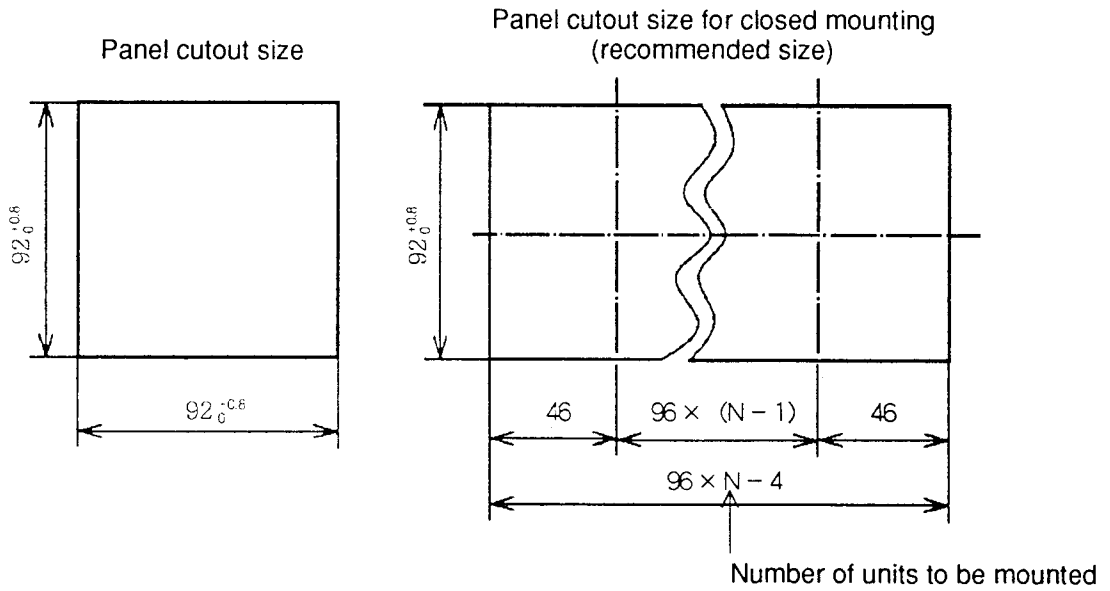

### Panel cutout size (recommended) with vertical and horizontal mounting

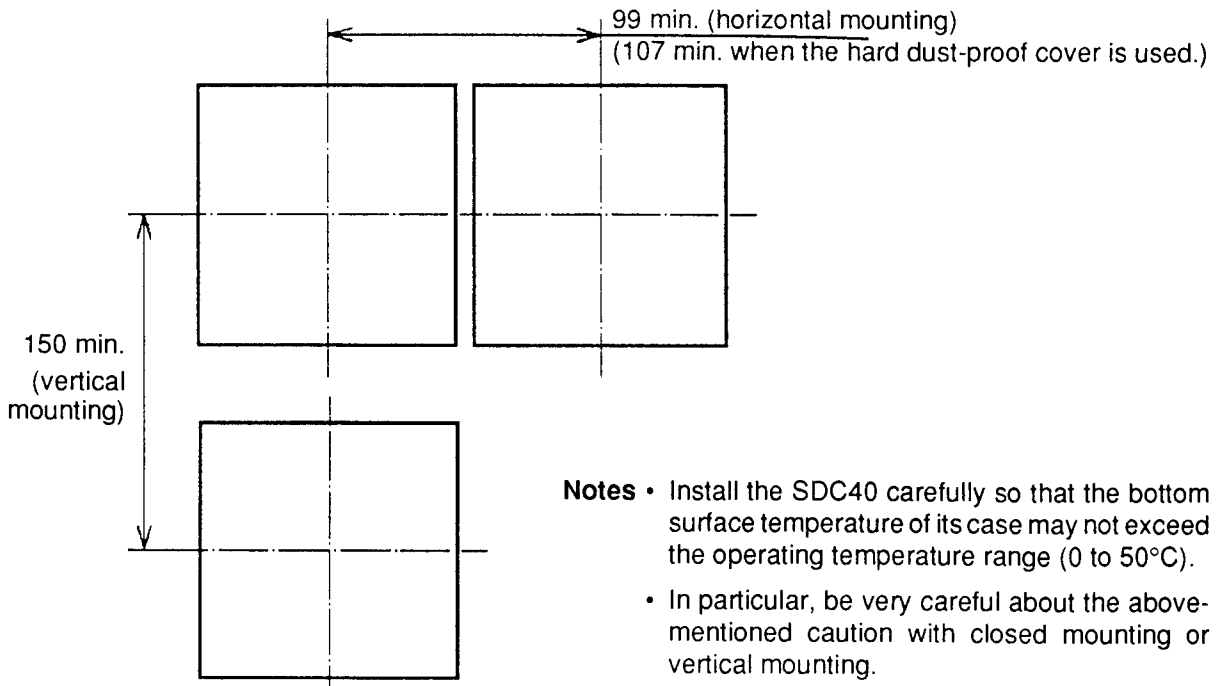

- Notes**
- Install the SDC40 carefully so that the bottom surface temperature of its case may not exceed the operating temperature range (0 to 50°C).
  - In particular, be very careful about the above-mentioned caution with closed mounting or vertical mounting.

## 2-3 Mounting

### 1. Location of mounting

Mount the instrument at a location which satisfies the following conditions.

- Mount the instrument in locations: Not subject to high or low temperatures, or high or low humidity.
- Free of corrosive gas (sulfide gas, etc.)
- Free of dust particles, soot, or the like
- Not exposed to direct sunlight or the weather
- Free of mechanical vibrations
- Do not mount instrument near a high-tension line, a welder, or electrical noise generating sources.
- Make sure the instrument is more than 15 meters from a boiler or other high-voltage ignition devices.
- The location should not be subject to a strong magnetic field.

### 2. Mounting method

- Mount the instrument before mounting the lower mounting bracket ①.
- After the parts a and b of the mounting fixture touch the mates (after looseness is eliminated at the front and back of the mounting bracket), tighten the screws by about one turn. Be careful since the case may be deformed by tightening the screws excessively.

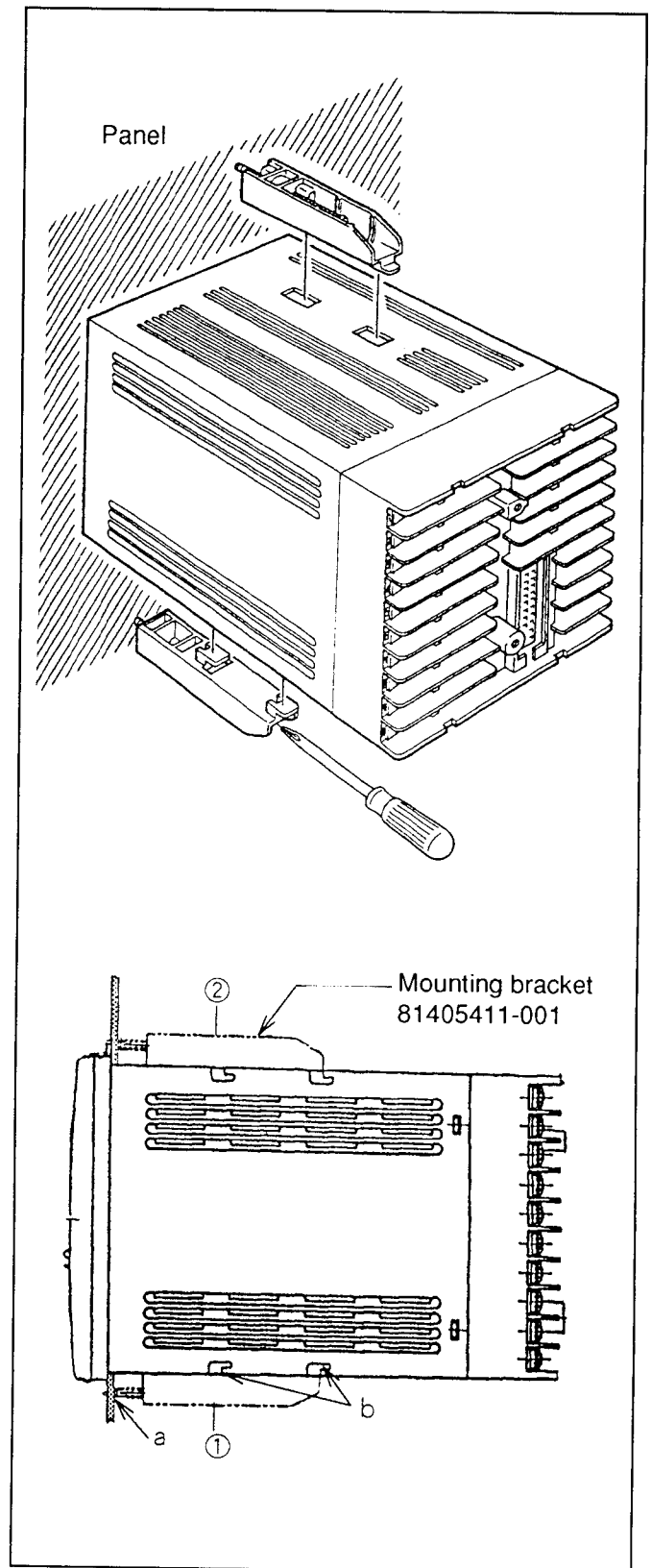

Mounting method (SDC40)

## Installation

- Mount the instrument so that it does not tilt horizontally more than  $10^\circ$  (+ or -).
- Use a steel panel with a plate thickness of more than 2mm.
- Fix the upper and lower panels of the instrument securely by using the attached mounting brackets.

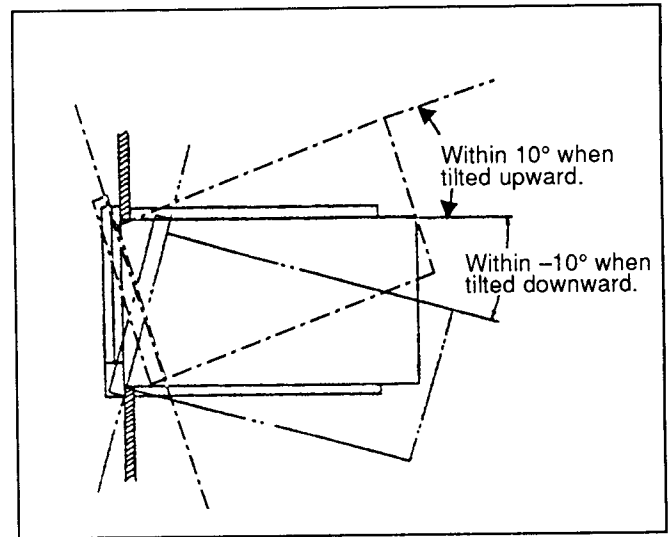

**Mounting angle**

## Chapter 3 WIRING

### 3-1 Cables

Connect thermocouple wires to the terminals in case of a thermocouple input. When a thermocouple is connected to terminals, or wiring distance is long, connect the wires via a shielded compensating lead wire.

- For input/output other than thermocouples, use a shielded polyethylene insulated vinyl sheathed cable for instrumentation use conforming to JCS-364 or equivalent (generally called twisted shielded cable for instrumentation use).
- A shielded multiconductor microphone cord (MVVS) may be used, if electromagnetic induction noise are comparatively low.

**Reference** Recommended twisted shielded cables

Fujikura Cable Co.	2 conductors	IPEV-S-0.9mm <sup>2</sup> x 1P
	3 conductors	ITEV-S-0.9mm <sup>2</sup> x 1T
Hitachi Cable Co.	2 conductors	KPEV-S-0.9mm <sup>2</sup> x 1P
	3 conductors	KTEV-S-0.9mm <sup>2</sup> x 1T

### 3-2 Terminal Connections

Use a crimped style solderless terminal compatible with M3.5 screw.

Caution 1 : Be sure to use round crimped style solderless terminals to prevent disconnection from terminals, if the instrument is mounted at a place subject to noticeable vibrations or impacts.

Caution 2 : Be careful not to allow any crimp style solderless terminals to touch adjacent terminals.

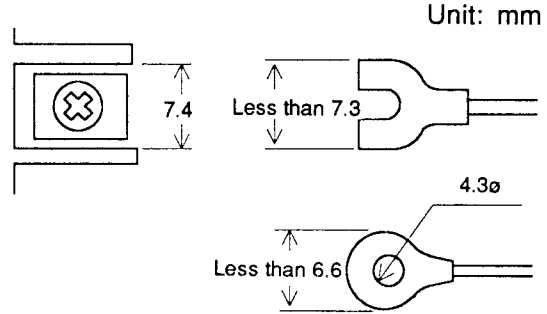

### 3-3 Terminal Arrangement and Recommended Direction of Wire Draw-out

Recommended directions of wire draw-out from the standard terminal base

(Be sure to follow this rule as to the direction of wire draw-out when using the extension terminal base.)

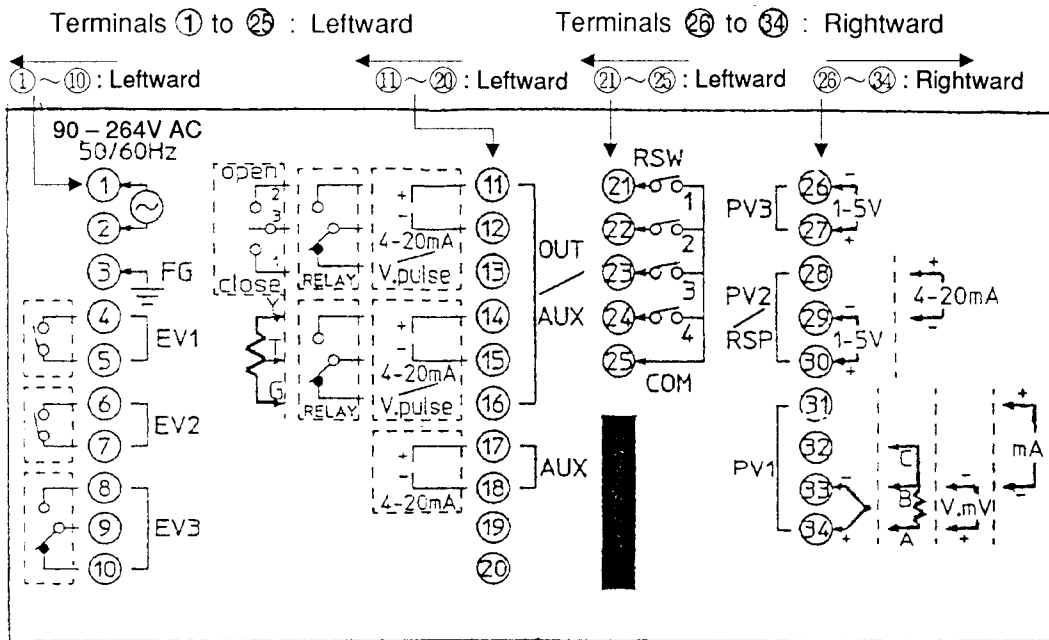

When connecting terminals 14, 15 and 16 to the YTG of the motor, bundle these wires separately from the other output wires

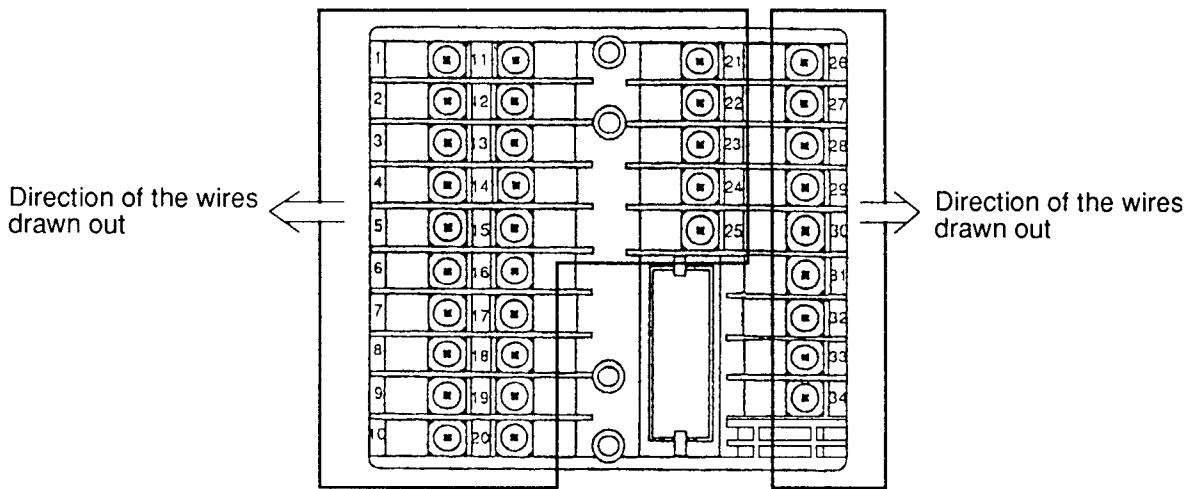

Standard terminal base layout

### 3-4 Power Supply Connections

- Obtain the SDC40A power source from a single-phase instrumentation power source not subject excess noise.
- If the power source generates noise, add an insulation transformer, and use a line filter.

Line filter Yamatake Corporation  
Model 81446364-001

Be careful not to bundle the primary and secondary coils of the power cable together. Do not put them into the same conduit or duct after introducing noise-reduction measures.

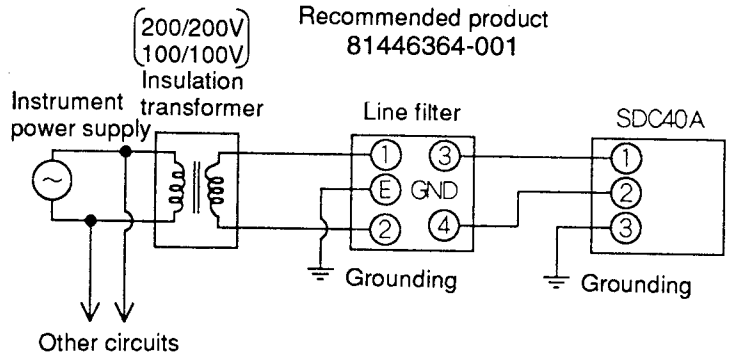
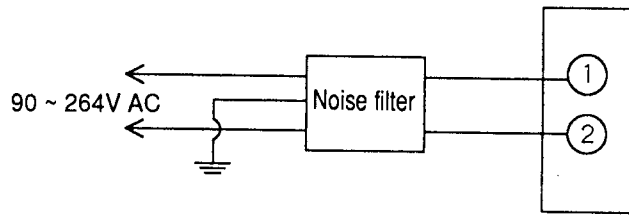

### 3-5 Grounding

Connect the instrument by one-point grounding to GND terminals (terminals ③ and FG terminal). Do not perform any jumper wiring. Mounting a grounding terminal strip separately, and connect shielded cables, etc. to the ground, if grounding work is difficult.

Grounding type :

Category 3 grounding or higher  
(Lower than 100Ω)

Grounding conductor :

Annealed copper wire more than  
2mm<sup>2</sup> (AWG14)

Grounding conductor length :

Max. 20m

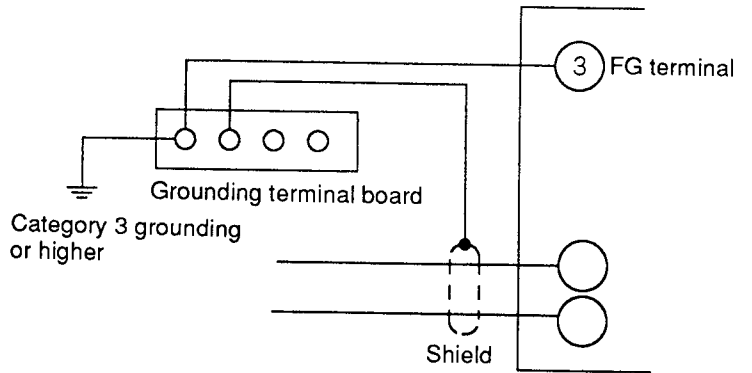

### 3-6 Terminal Connection Diagrams of Standard and Extension Terminal Bases

• Standard terminal layout

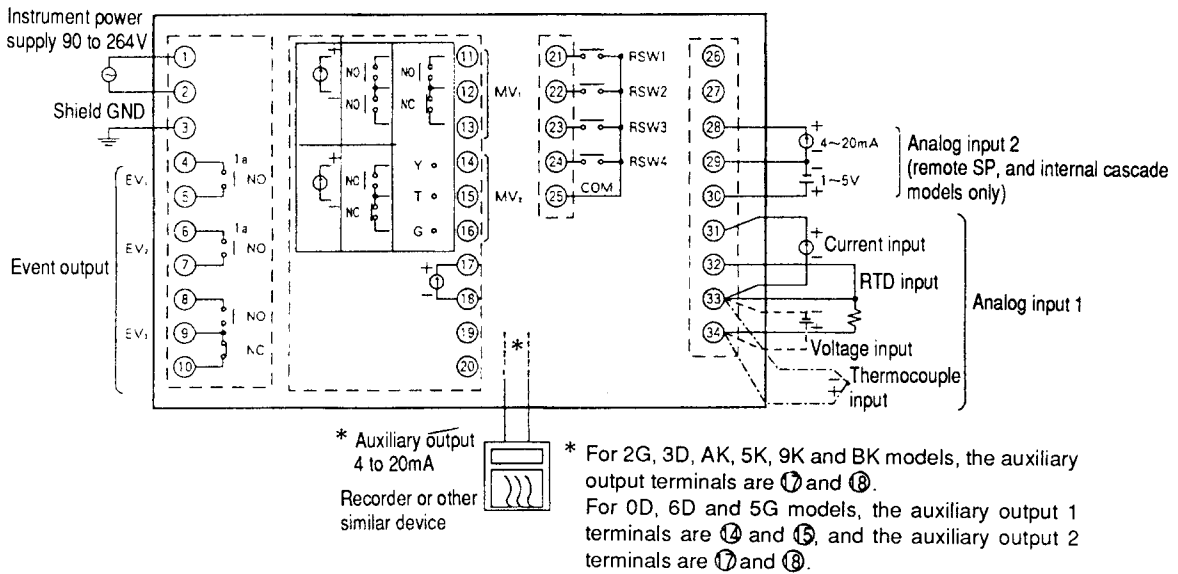

• Extension terminal layout

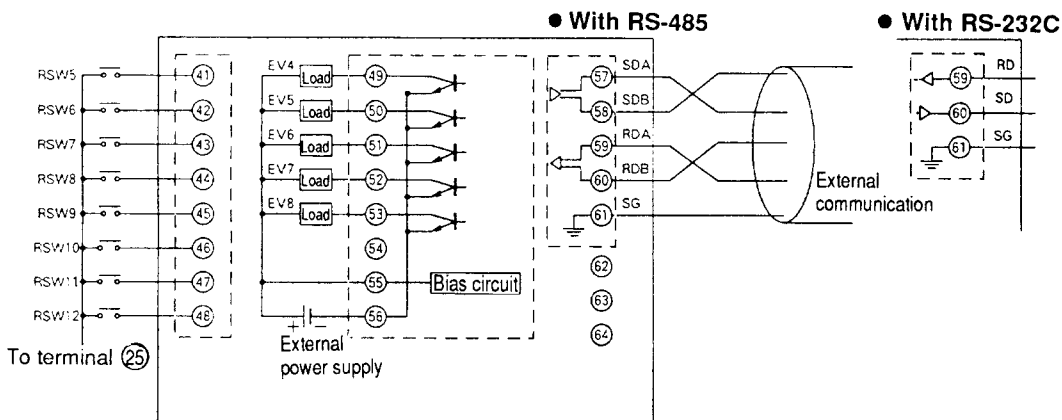

### 3-7 Input 1 (PV1) Connection

The input 1 is of a multi input type corresponding to various sensors. Connect the input 1 terminals according to each sensor as shown below.

**Note 1 :** Be careful not to apply voltage to the linear current sensor terminals (31, 33). Otherwise the instrument may malfunction.

**Note 2:** Be careful about the polarity of each sensor when making connection.

**Note 3:** Use a shielded cable for connection of each sensor.

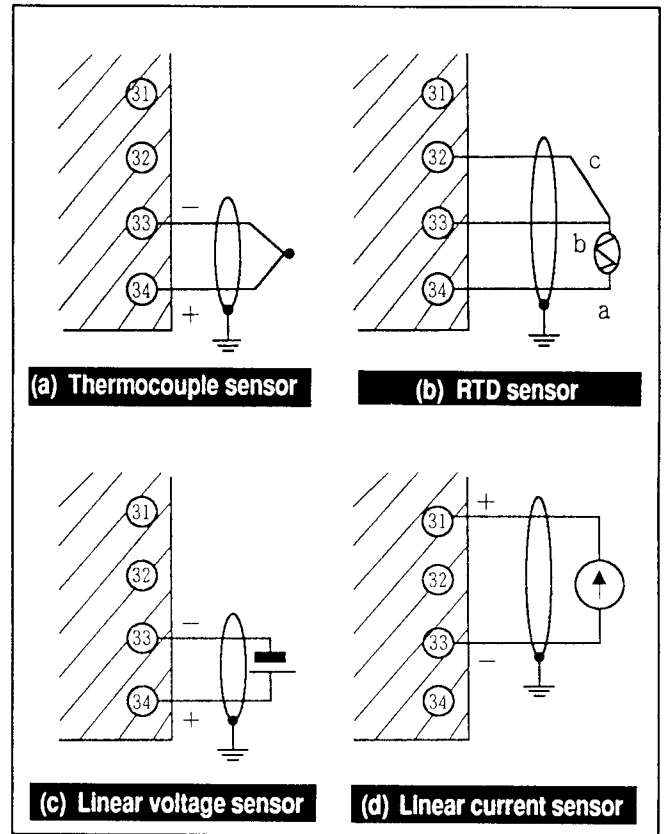

### 3-8 Input 2 (PV2/RSP) Connection (remote SP, and internal cascade models only)

Connect either instrumentation input of 1 to 5V DC or 4 to 20mA DC to the input 2 terminals as shown below.

**Note 1 :** Be careful not to apply voltage to the input terminals of 4 to 20mA DC (28, 29). Otherwise the instrument may malfunction.

**Note 2:** Be careful about the polarity of the input when making connection.

**Note 3:** Use a shielded cables for connection of the input.

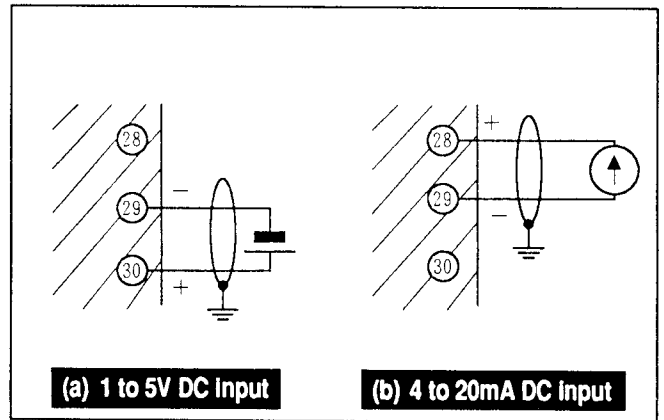

### 3-9 Control Output Connection

The control output of this instrument is determined, depending upon the model number. After sufficiently checking the model numbers of this instrument and the actuator to be used, make connections. Note that the control output of each model cannot be changed into any other type of control output.

#### 1. With single output

Connect the relay output (0D), current output (5G) or voltage output (6D) as shown below.

**Note :** When a small current/low voltage is to be switched, use a bleeder resistance to obtain the sufficient current/voltage value for the minimum switching capacity of the relay.

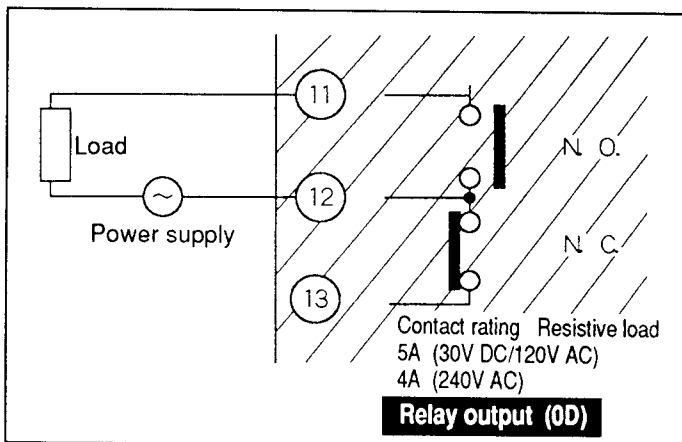

**Note :** Never connect nor disconnect the actuator with the power supply to this instrument kept closed. Otherwise, the actuator may cause a fault.

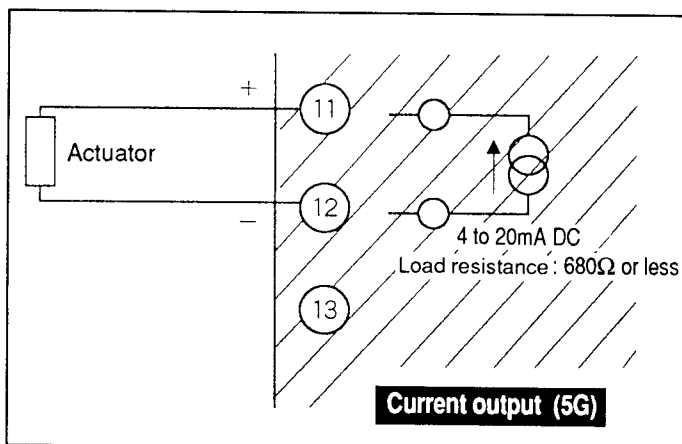

**Note :** The voltage output circuit is a constant-current circuit internally. Set the current value by setup C79 according to the conditions for the SSR and load to be used to obtain an optimum voltage. At delivery from the factory, this voltage is set to the same value as the voltage value of general SSR.

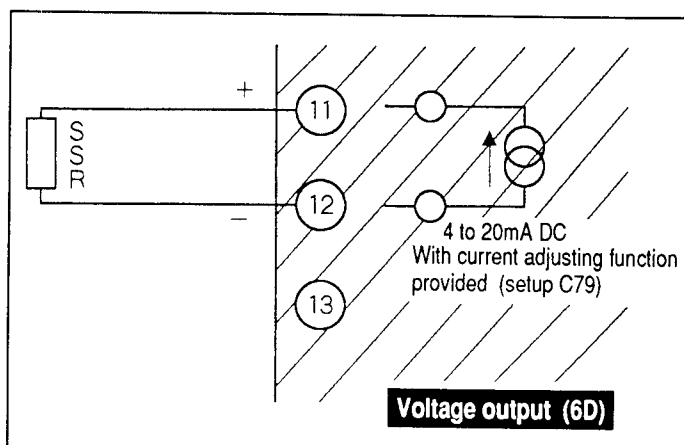

**2. With position proportional output (2G)**

Connect the feedback resistor and control output as shown below, exercising utmost care about the switching direction.

**Note 1:** The built-in relay has a limited life. Avoid setting such PID constants that ON-OFF operation of the relay is repeated excessively.

**Note 2:** When a motor for 100V/200V AC is to be used, exercise care about the inrush current as well as the contact rating, and use an auxiliary relay when necessary.

**Note 3:** Never lay the cable to the motor terminals (11), (12) and (13) and that to the feedback resistor terminals (14), (15) and (16) through the same wire duct, nor connect a 6-conductor cable to these terminals, but separate the above-mentioned two cables 30cm or more from each other. Otherwise, this instrument may cause a trouble due to the starting noise, etc. of the motor.

**Note 4:** Terminals (14), (15) and (16) may not be required (when no feedback resistor is provided).

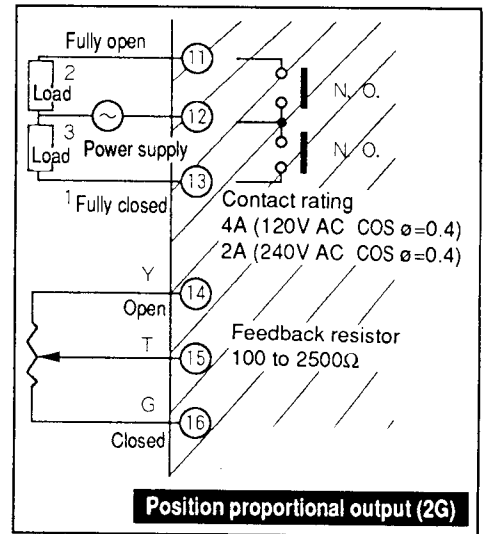

**3. With heat/cool control output (5K, AK, BK, 9K, 3D)**

The single outputs are combined. Make connection as shown below. Set the heat side and cool side by parameters in advance.

As for precautions in connection, observe the notes given in the case of the single output.

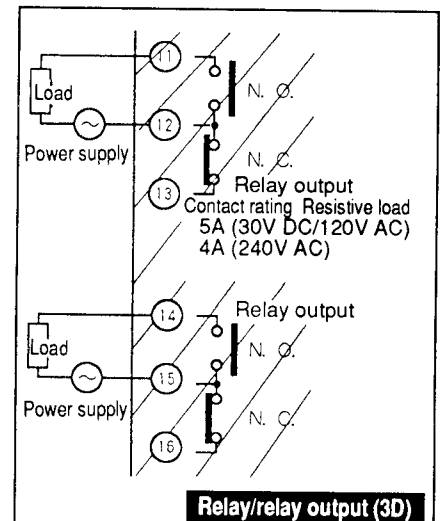
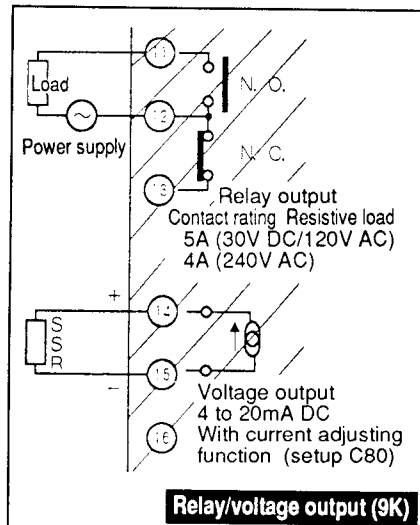
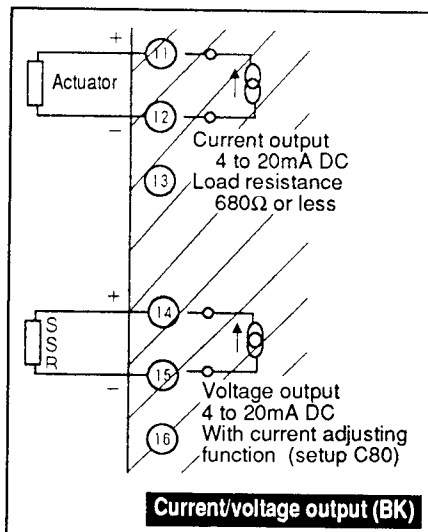
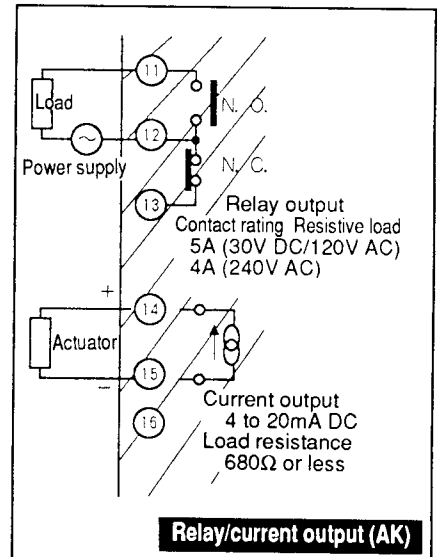
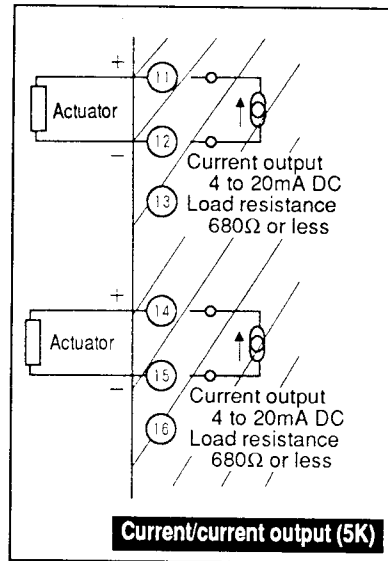

### 3-10 Connection of Auxiliary Output 1, 2 (option)

This instrument can be provided with up to one auxiliary output when the control output is position proportional (2G) output or heat/cool output, and up to two auxiliary outputs in case of any other control output.

The terminals ⑰ and ⑱ only are used for the auxiliary output in case of 2G "heat/cool control". In any other cases, the terminals ⑭ and ⑮ are used for auxiliary output 1, and the terminals ⑰ and ⑱ for auxiliary output 2.

**Note 1:** Never connect nor disconnect the receiver with the power supply to this instrument kept on. Otherwise, the receiver may cause a trouble.

**Note 2:** Use shielded cables for connection.

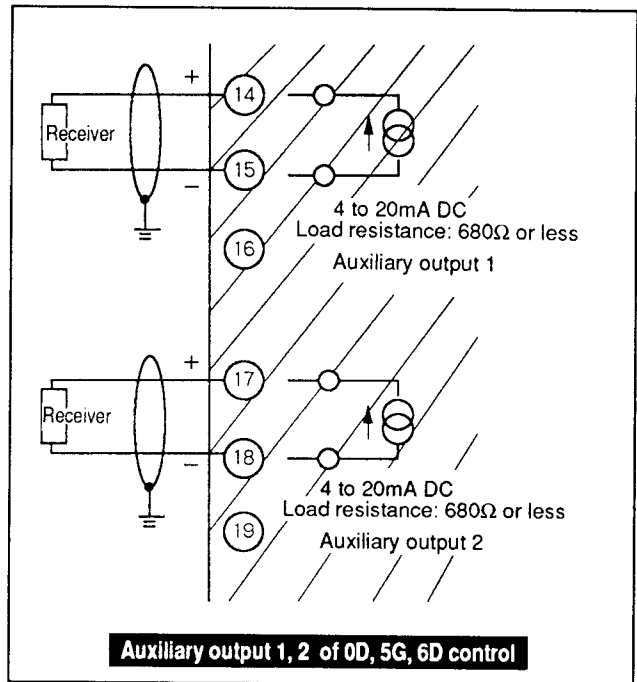
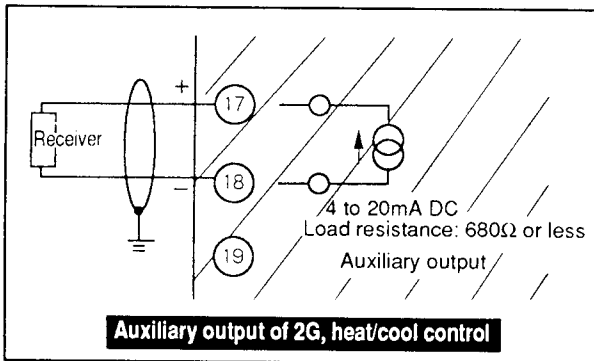

### 3-11 Connection of Relay Event Output

This instrument is provided with two points (1a contact each) of relay event output as standard, and one point (1a1b contact) of relay event output as option. Connect these relay event outputs as shown below.

**Note :** When a small current/low voltage is to be switched, use a bleeder resistance to obtain the sufficient current/voltage value for the minimum switching capacity of the relay.

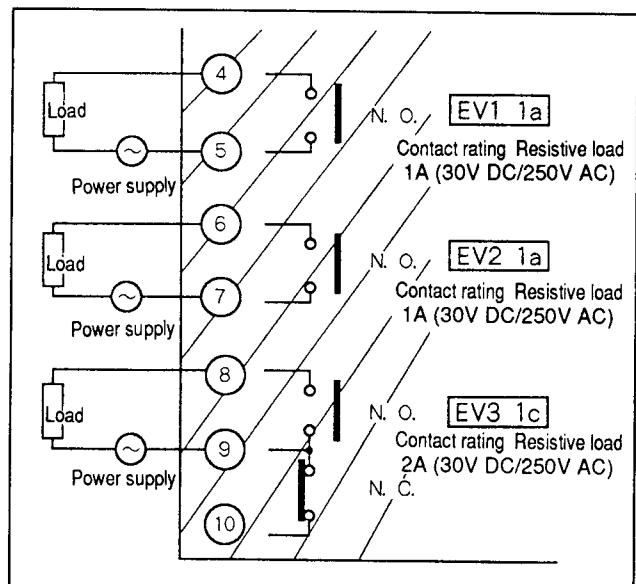

### 3-12 Connection of Open Collector Event Output (option)

Make wiring on the attached terminal base.

- Note 1:** Be sure to connect the terminal (55) to the + terminal of the external power supply. Otherwise, the event output does not operate.
- Note 2:** Never short circuit between the + terminal of the external power supply and terminals (49) to (53) of this instrument. Otherwise, the event output becomes defective. (A short circuit preventive circuit is not incorporated.)
- Note 3:** When a semiconductor load such as a program controller (sequencer) is to be connected, select such a module that the direction of current is coincident. This load must not be affected adversely by a leak current when the event output of the instrument is turned off.

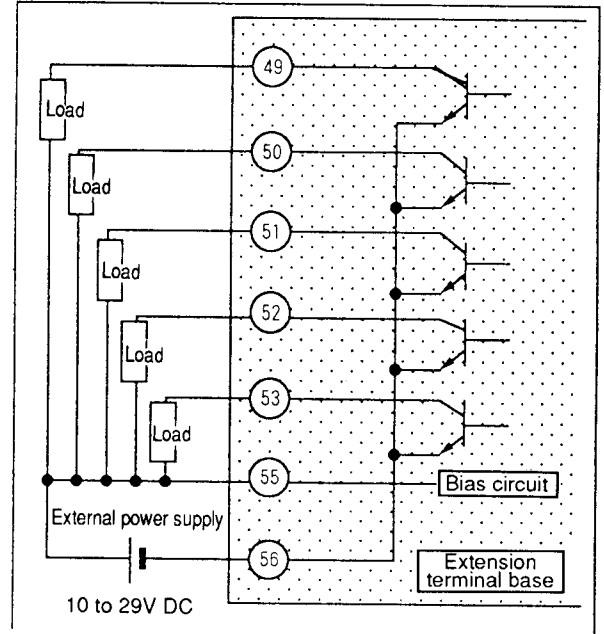

### 3-13 Connection of Remote Switch Input (option)

This instrument can be provided with 4 points or 12 points (8 points out of 12 points are mounted on the extension terminal base) of remote switch input as option. In case of 12 points of remote switch input, wiring is made on both standard terminal base and extension terminal base.

- Note 1:** The remote switch used for this instrument is of a built-in power supply (open voltage 12V DC) type. Be sure to operate the external contacts as no-voltage contacts.
- Note 2:** Use gold contacts or the like, which can turn on and off a small current, as no-voltage contacts. Other kinds of relay contacts may not be able to turn on and off a small current. Use such contacts that have sufficient margin in the minimum switching capacity with respect to the contact current and open voltage of this instrument.
- Note 3:** When semiconductors (such as open collector) are used as no-voltage contacts, the voltage across the contacts should be 3V max. when the contacts are turned on. The leak current at turn-off time should be 100 $\mu$ A max.

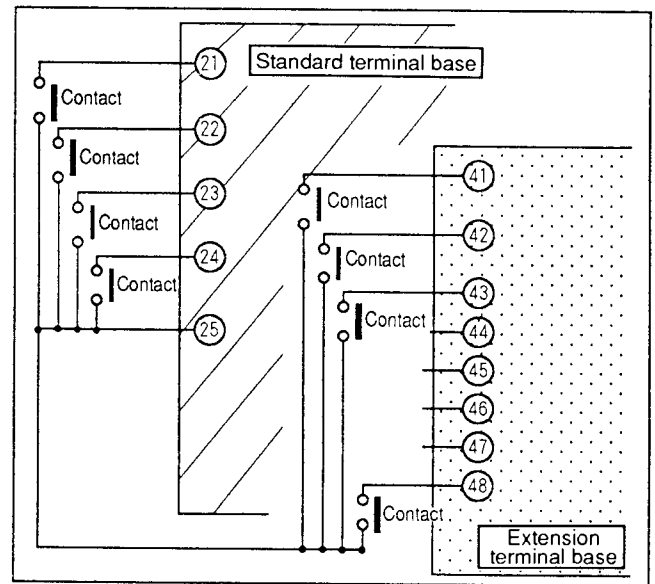

- Note 4:** A remote switch can be connected in parallel with two or more SDC40 series units. When it is to be connected in parallel with this instrument and other type of instrument, check the conditions for the other instrument sufficiently before instrumentation.

Internal circuit of portion of this instrument where remote switches are connected

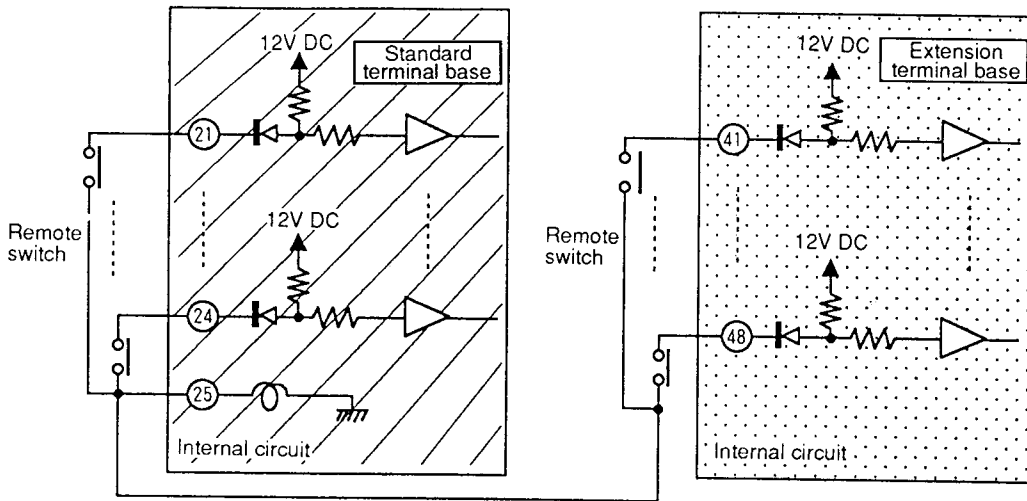

3-14 Communication (option) Connection

The communication functions of this instrument are classified into RS-232C type and RS-485 type by the model number. After checking the communication type of your instrument, make connection as shown below.

**Note 1:** This instrument always serves as a slave station. The RS-485 type permits slave stations to be multi-connected.

**Note 2:** In the RS-485 (5-wire system), connect one each terminating resistor between the RDA and RDB terminals of each of the master station and the slave station furthest from the master station. Use the terminating resistors of 150Ω and 1/2W min.

**Note 3:** When making three-wire system connection in the RS-485 type, short circuit between (57) and (59) and between (58) and (60) of this instrument.

**Note 4:** In the RS-485 (3-wire system) type, connect one each terminating resistor to both physical ends of RDA and RDB lines, or both physical ends of SDA and SDB lines. Use the terminating resistors of 150Ω and 1/2W min.

**Note 5:** Be sure to assign a unique address to each slave station.

**Note 6:** Never short circuit between RDA and RDB or SDA and SDB terminals. Otherwise, this instrument may be damaged.

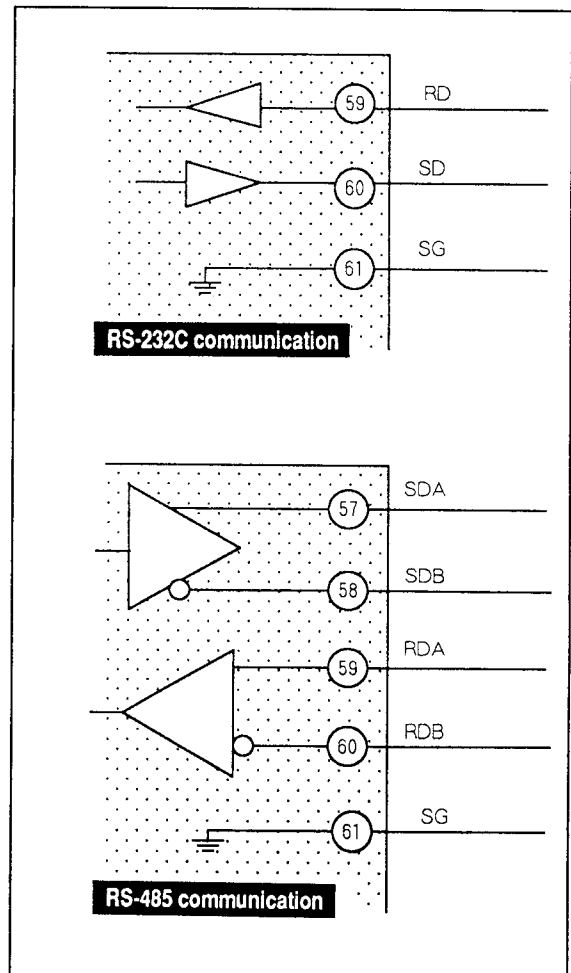

### 5-wire system RS-485 interconnection diagram

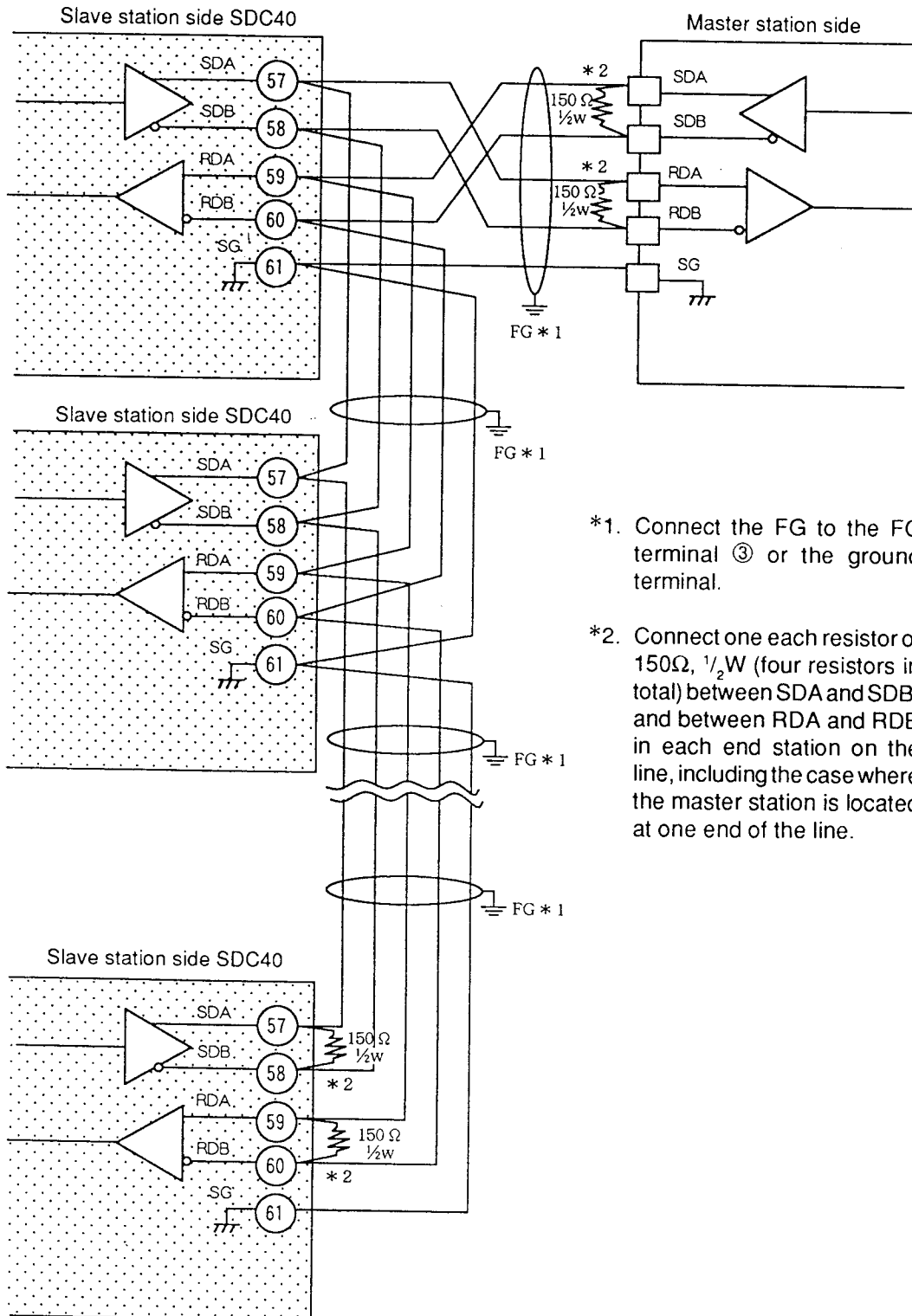

\*1. Connect the FG to the FG terminal ③ or the ground terminal.

\*2. Connect one each resistor of 150Ω, 1/2W (four resistors in total) between SDA and SDB, and between RDA and RDB in each end station on the line, including the case where the master station is located at one end of the line.

### 3-wire system RS-485 interconnection diagram

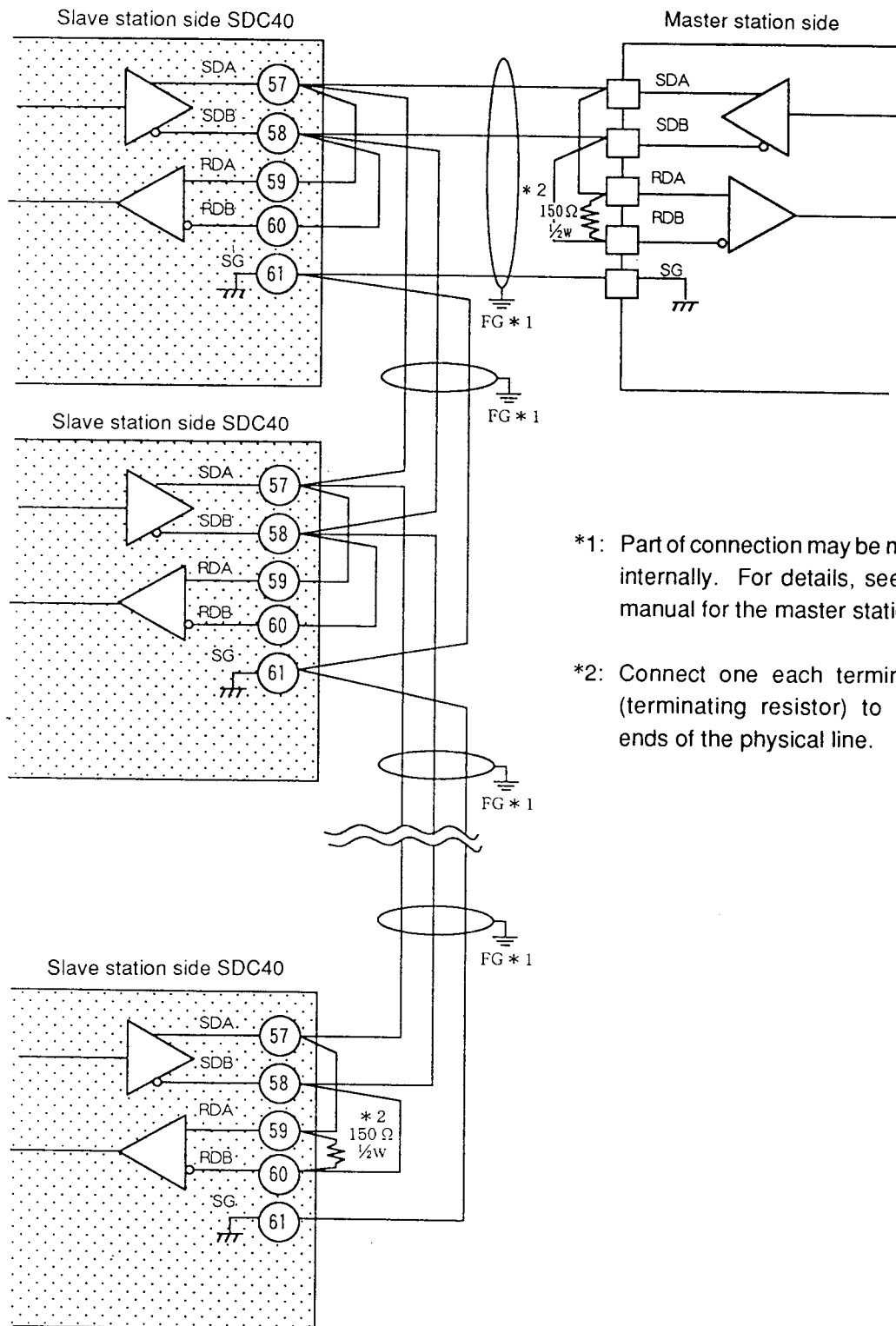

\*1: Part of connection may be made internally. For details, see the manual for the master station.

\*2: Connect one each terminator (terminating resistor) to both ends of the physical line.

### 3-15 Wiring Precautions

- Connect cables according to the instrument model number and terminal numbers on the label mounted on the side panel of this instrument. After wiring, make sure the wiring connections are correct.
- Separate input/output signal cables and communication cables more than 50cm from a drive power cable or a power cable higher than 100V. Don't pass these cables together through the same conduit or duct.
- Be careful not to allow crimped style solderless terminals to touch any adjacent terminals.
- When the thermocouple input or the like of this instrument is to be connected in parallel with other instruments, the total input impedance of the other instruments should be 1M $\Omega$  min. If the total input impedance is less than 1M $\Omega$ , a sensor disconnection may not be able to be detected.
- Cautions in combination with data input device

When the input/output (parallel connection in case of input) of the SDC40 is applied to an A/D converter or analog scanner, setc., such a trouble as dispersion in read data may occur. To prevent this trouble from occurring, take any of the following remedial measures.

[Remedial measures]

1. Use a low speed integral type A/D converter.
2. Insert an isolator having no switching power supply between the SDC40 and A/D converter.
3. Perform averaging processing by a personal computer during data reading.
4. Set an input filter to the device if possible.

### 3-16 Noise

#### 1. Noise generation sources

The following noise generation sources are the most common.

- |   |                                 |
|---|---------------------------------|
| ① Relay and contacts                              | ⑥ Phase angle control SCR       |
| ② Solenoid coils and solenoid valves              | ⑦ Radio communication equipment |
| ③ Power line (higher than 100V AC, in particular) | ⑧ Welding machine               |
| ④ Inductive load                                  | ⑨ High-voltage ignition devices |
| ⑤ Motor commutator                                |                                 |

#### 2. Measures for noise suppression

- A CR filter is effective for quick-rising noises such as impulse noise.

Recommended CR filter    Yamatake Corporation Model No. 8144636365-001

- A varistor is effective for noises with high crest values.

Be careful since the varistor is shorted if it malfunctions.

Recommended varistor    Yamatake Corporation Model No. 81446366-001 (for 100V)  
81446367-001 (for 200V)

### 3-17 Isolation between Input and Output

The following figure shows the mutual isolation between the input and output. In the following figure, the section bounded by a solid line is isolated from the rest of the circuit. The section bounded by a dotted line is not isolated from the rest of the circuit.

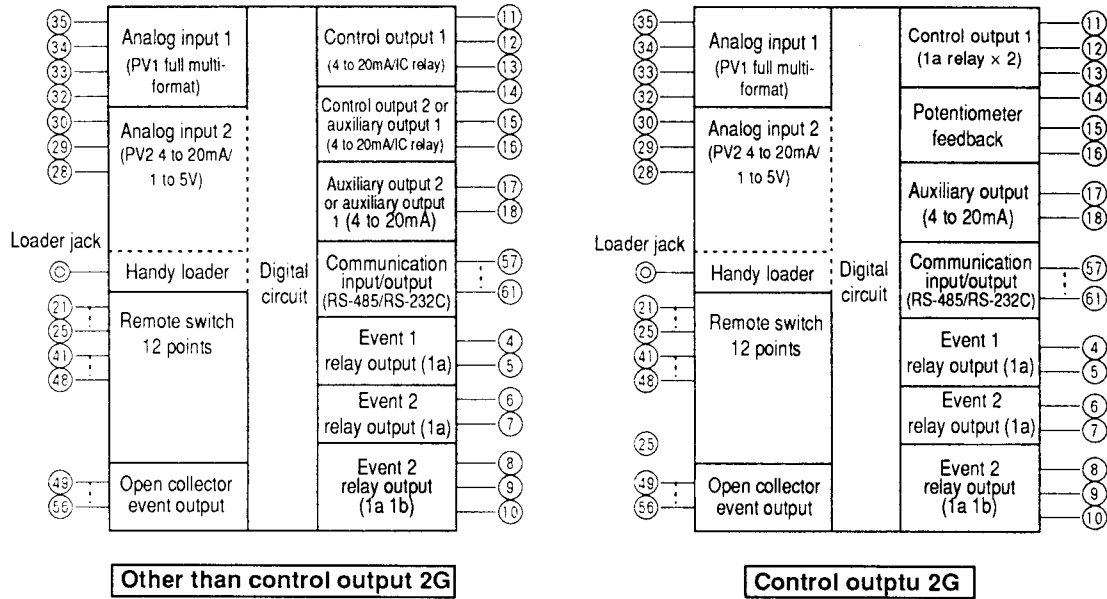

\* Since the loader jack part is not isolated from the internal digital circuit, handle it very carefully.

## Chapter 4 OUTLINE OF SETTING

### 4-1 Initialize

This instrument employs such a system that various settings and selections can be done from the keys or handy loader so as to be adaptable to various applications.

For this purpose, necessary data are required to be input as initialize. When the power supply to the instrument is turned on for the first time, first set the setup (SETUP) items by key-in operation (Chapter 7). Determine the basic features of the instrument by the setup items, then set the parameters (PARA) (Chapter 5). The setup items prepared need not be changed so frequently once they are set. When these setup items are set by key-in operation, they cannot be changed in any other than the READY mode.

### 4-2 Major Setup Items (block diagram)

The major setup items from input to output are collected in the block diagram given on the following pages. The symbols in the diagram are as shown below.

C□□ : Setup (SETUP) item number  
PARA□□ : Parameter (PARA) item number



(Continued from preceding page)

**<RUN/READY, AUTO/MAN, Fixed value output>**

Control output quantity in READY mode	C26, C27
Output at input overrange	C19, C20
Fixed value output 1 to 3	C23~C25
Manual change mode	C21
Preset manual value	C22

**<Control output adjustment>**

Motor drive adjustment	PARA40~ PARA44
Voltage output adjustment	C79, C80

Control output

**<Indication, UF keys>**

Selection of indication contents of bar graph indicator	C71
Green belt setting range	PARA38, PARA39
Indication 1 digit masking	PARA45
Indication output of LED for UF	C69, C70
Function assignment of UF1 key	C55~C59
Function assignment of UF2 key	C60~C68

**<Auxiliary output>**

Setting of auxiliary output 1	C32~C36
Setting of auxiliary output 2	C37~C41

**<Event>**

Event type, stand-by	PARA15~ PARA31
Event in READY mode	C28

● Internal cascade model

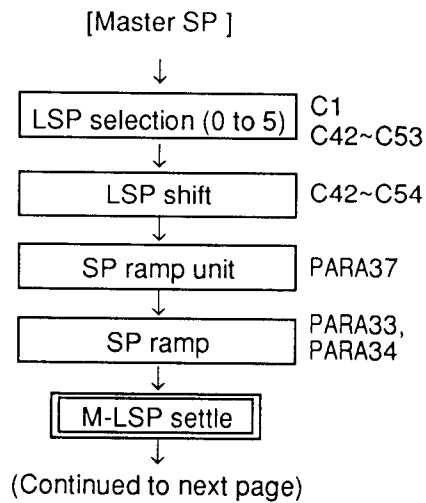
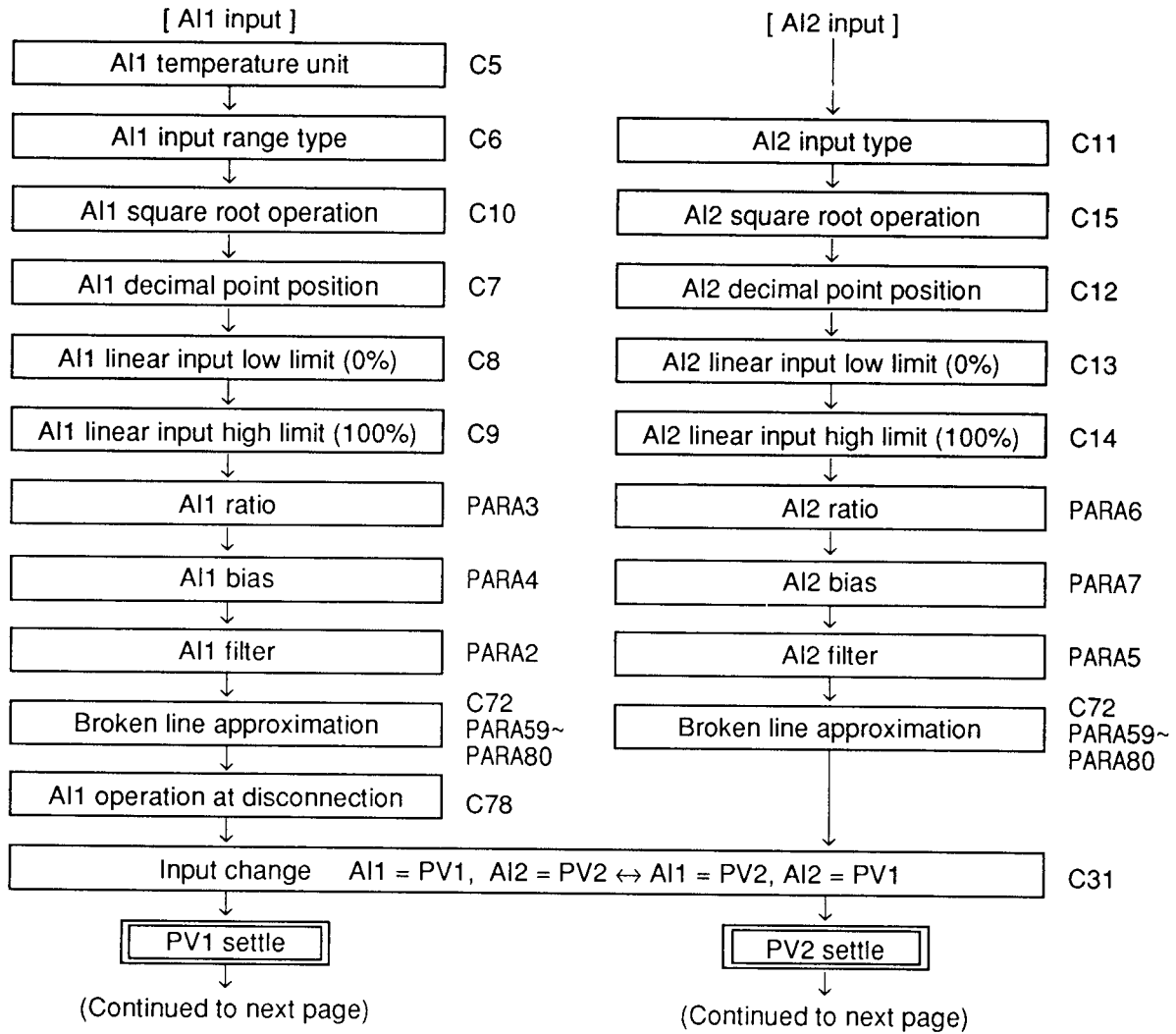

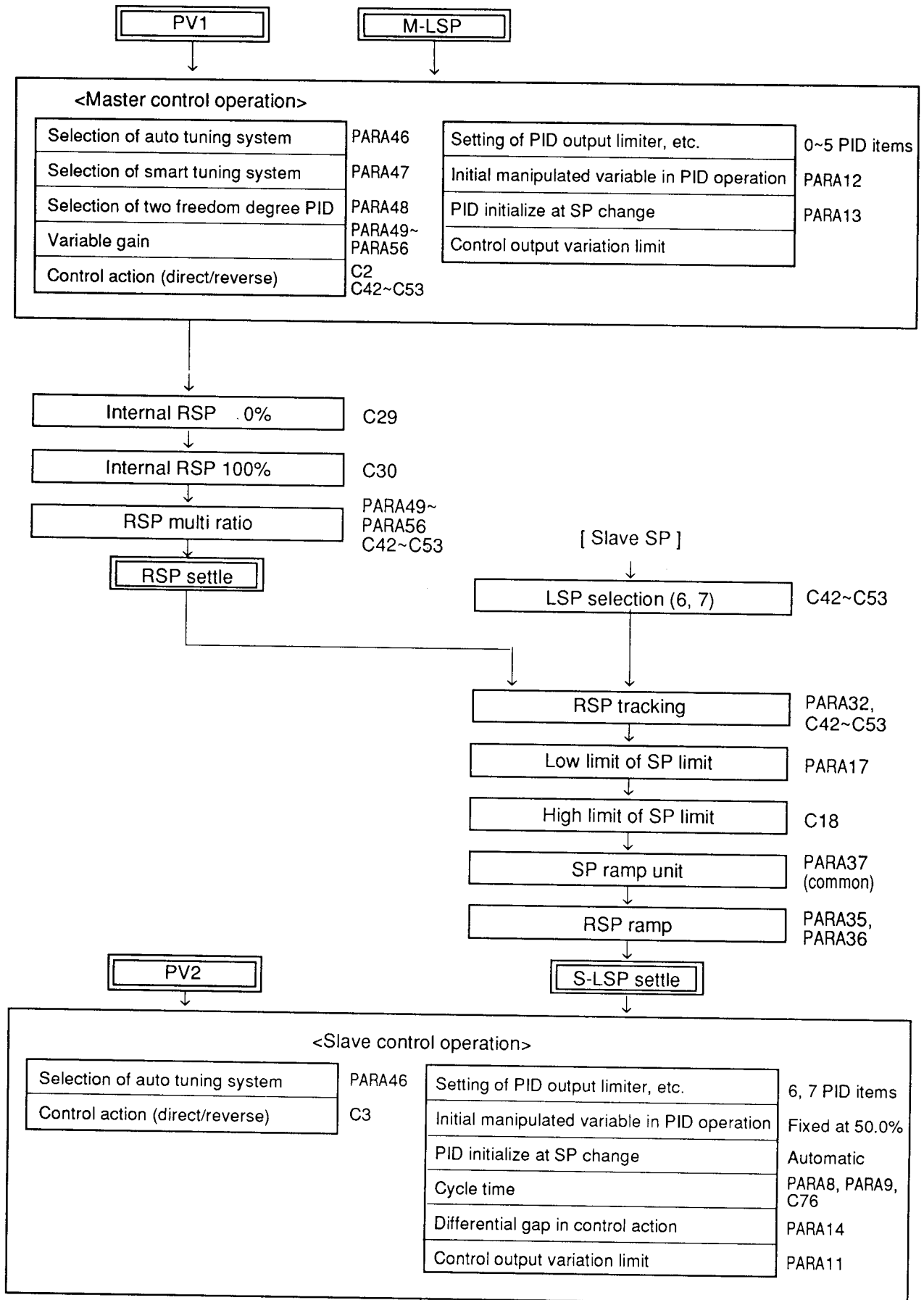

(Continued to next page)

(Continued from preceding page)

↓

<b>&lt;RUN/READY, AUTO/MAN, Fixed value output&gt;</b>	
Control output quantity in READY mode	C26, C27
Output at input overrange	C19, C20
Fixed value output 1 to 3	C23~C25
Manual change mode	C21
Preset manual value	C22

↓

<b>&lt;Control output adjustment&gt;</b>	
Motor drive adjustment	PARA40~ PARA44
Voltage output adjustment	C79, C80

↓

Control output
----------------

<b>&lt;Indication, UF keys&gt;</b>	
Selection of indication contents of bar graph indicator	C71
Green belt setting range	PARA38, PARA39
Indication 1 digit masking	PARA45
Indication output of LED for UF	C69, C70
Function assignment of UF1 key	C55~C59
Function assignment of UF2 key	C60~C68

<b>&lt;Auxiliary output&gt;</b>	
Setting of auxiliary output 1	C32~C36
Setting of auxiliary output 2	C37~C41

<b>&lt;Event&gt;</b>	
Event type, stand-by	PARA15~ PARA31
Event in READY mode	C28

# Chapter 5 SETTING OF PARAMETER (PARA) ITEMS

## 5-1 Parameter Operation

### 1. Prior to setting

Parameter items whose settings must be changed several times to improve the control functions as the results of operation of this instrument are collected for this instrument. After the system is placed in stationary operation, it is almost unnecessary to change the settings of these parameters.

There are about 50 to 80 parameter items to be set, changing depending upon the model. There are also such parameters that the same contents of setting are shared by several items or the values set at delivery from the factory can be used as they are. Therefore, to complete the proper parameter settings in short time, it is recommended to decide the parameter values in advance, using the "user's setting column", and then make actual parameter settings.

### 2. How to set and reset the parameter setting mode

Parameter setting can be done in any status (RUN/READY, AUTO/MAN, etc.) so far as the instrument is placed in the basic indication status.

In the basic indication status, a PV is indicated on the No. 1 indicator, and an SP is indicated on the No. 2 indicator. This status can be set by pressing the <sup>DISP</sup> key. Even when DEV or OUT is indicated on the No. 2 indicator in place of SP, the parameter setting mode can be set.

Three setting groups can be called sequentially by pressing the <sup>PARA</sup> key in the basic indication status. When the <sup>ENT</sup> key is pressed with **PARA** indication, the parameter item can be set. To reset the parameter setting mode, press the <sup>DISP</sup> key. The basic indication status can be reset from any status.

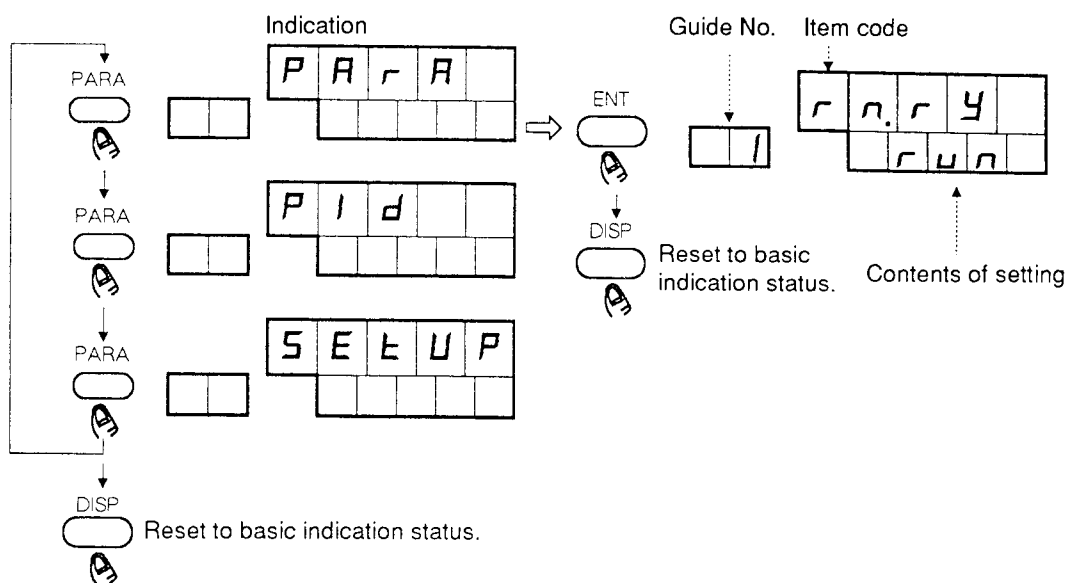



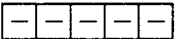

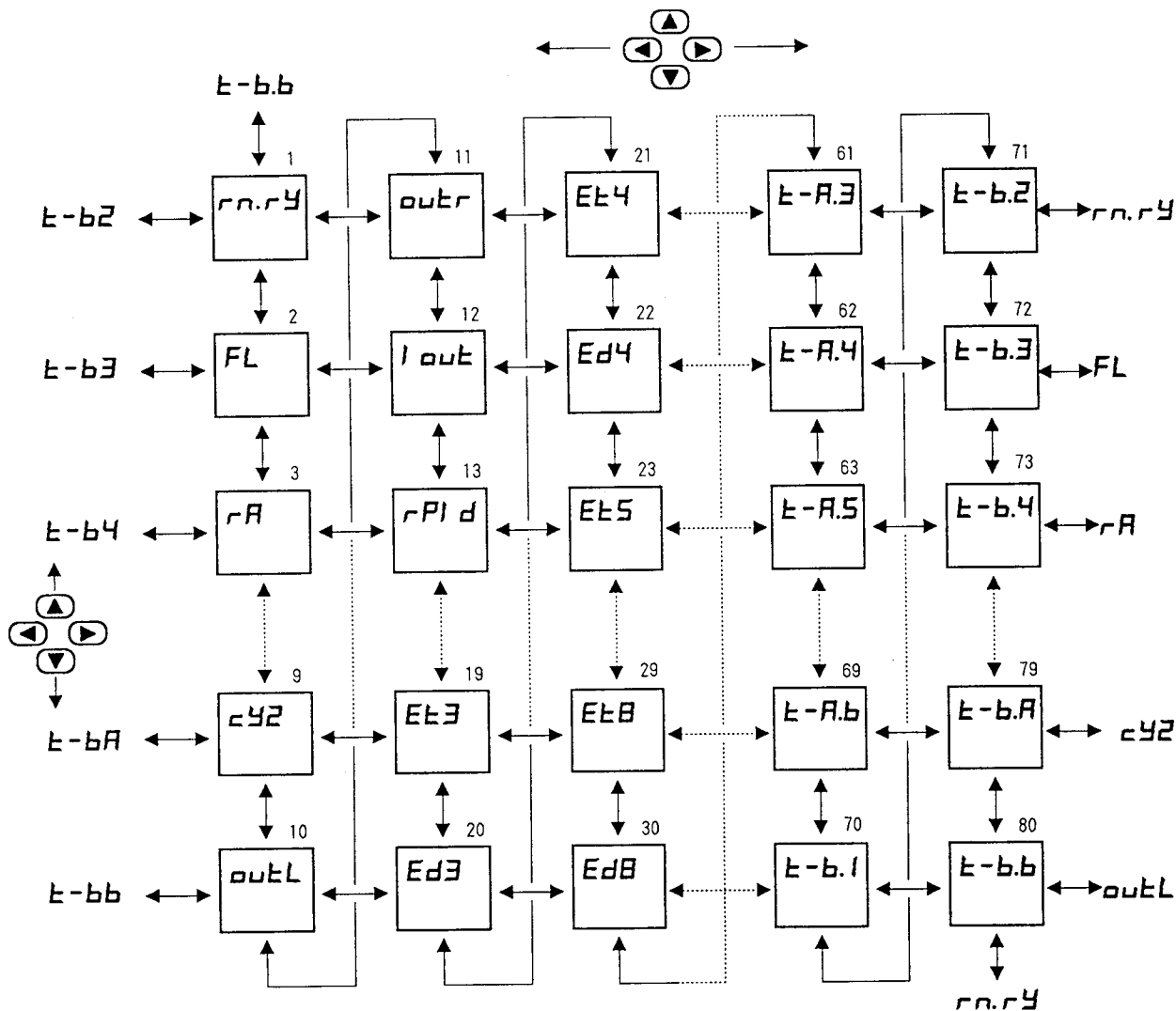
### 3. How to move the parameter items

The parameter items have a matrix construction like the two other setting groups. Each can be moved optionally by  keys as shown below.  is indicated in the No. 2 indicator for an unnecessary item, depending upon the model or the contents of setting. The figure given at the right top of a frame denoting each item means Guide No.



### 4. How to change the set value of a parameter item

To change the set value of a parameter item, press the  key when this item is indicated. The set value on the No. 2 indicator flashes, indicating that it can be readily changed. Set a desired value with  keys, and press the  key. This value is stored, and flashing stops.



If the previous value is restored when the set value flashes, don't press the  key, but press the  key to reset to the basic indication status. Then, make the same setting operation.

5-2 Parameter Item Table

Guide No.	Item code	Item	Set value at delivery from factory	User's setting column	Setting
1	<i>run.rdy</i>	RUN/READY selection	<i>rdy</i>		<p><i>run</i> : RUN <i>rdy</i> : READY</p> <p><b>Supplement</b> Setup cannot be changed in other than READY (indication only possible).</p>
2	<i>FL</i>	AI1 filter	0.0		<p>0.0 to 120.0s</p> <p><b>Supplement</b> No filter is provided at 0.0s</p>
3	<i>rR</i>	AI1 ratio	1.000		0.001 to 9.999
4	<i>bl</i>	AI1 bias	0		-1000 to 1000U
5	<i>FL2</i>	AI2 filter	0.0		<p>0.0 to 120.0s</p> <p><b>Supplement</b> No filter is provided at 0.0s AI2 functions as RSP in the remote SP model, and as PV2 in the internal cascade model.</p>
6	<i>rR2</i>	AI2 ratio	1.000		0.001 to 30.000
7	<i>bl2</i>	AI2 bias	0		-19999 to 30000U
8	<i>cy</i>	Time proportional cycle (output 1)	10		<p>5 to 120s (relay output type) 1 to 60s (voltage output type)</p>
9	<i>cy2</i>	Time proportional cycle (output 2)	10		<p>5 to 120s (relay output type) 1 to 60s (voltage output type)</p>
10	<i>outL</i>	Control output variation limit	0.0		<p>0.0 to 10.0% (updated every 0.1s) No limit is provided at 0.0.</p>
11	<i>outR</i>	Control output variation limit (MV2 of internal cascade model)	0.0		<p>0.0 to 10.0% (updated every 0.1s) No limit is provided at 0.0.</p>
12	<i>1 out</i>	PID operation initial manipulated variable at power on	0		0 to 100%

Guide No.	Item code	Item	Set value at delivery from factory	User's setting column	Setting
13	<i>r P I d</i>	PID operation initialize at SP change	0		<p>0: Initialize decision is made automatically.</p> <p>1: Initialized at each time of SP change and SP write</p> <p>2: Not initialized at each time of SP change and SP write.</p> <p><b>Supplement</b> SP change includes change into RSP.</p>
14	<i>d I F F</i>	Differential gap at on-off control	50U		0 to 1000U Indicated in 0D, 6D output type.
		Dead zone at position proportional control	5.0		0.5 to 25.0% Indicated in 2G output type.
		Dead zone at heat/cool control	0.0		-100.0 to 50.0% Indicated in heat/cool output type.

Guide No.	Item code	Item	Set value at delivery from factory	User's setting column	Setting	
15	<i>E11</i>	Event 1 type	0		Event type 0: Direct PV 1: Reverse PV 2: Direct deviation 3: Reverse deviation 4: Direct absolute deviation value 5: Reverse absolute deviation value 6: Direct MV 7: Reverse MV 8: Direct RSP 9: Reverse RSP 10: Direct SP 11: Reverse SP 12: Direct motor feedback 13: Reverse motor feedback 14: Process alarm 15: All alarm sum 16: PV range alarm 17: Instrument alarm (except for PV range alarm) 18: Auto tuning status 19: Manual status 20: READY status 21: Local status 22: Direct PV2 23: Reverse PV2 24: Direct deviation PV2 25: Reverse deviation PV2 26: Direct absolute deviation value PV2 27: Reverse absolute deviation value PV2 28: Direct MV2 29: Reverse MV2 30: Direct SP2 31: Reverse SP2 32: Direct internal RSP 33: Reverse internal RSP 34: MFB presumed position control	
16	<i>E12</i>	Event 1 stand-by	0			
17	<i>E21</i>	Event 2 type	0			
18	<i>E22</i>	Event 2 stand-by	0			
19	<i>E31</i>	Event 3 type	0			
20	<i>E32</i>	Event 3 stand-by	0			
21	<i>E41</i>	Event 4 type	0			
22	<i>E42</i>	Event 4 stand-by	0			
23	<i>E51</i>	Event 5 type	0			
24	<i>E52</i>	Event 5 stand-by	0			
25	<i>E61</i>	Event 6 type	0			
26	<i>E62</i>	Event 6 stand-by	0			
27	<i>E71</i>	Event 7 type	0			
28	<i>E72</i>	Event 7 stand-by	0			
29	<i>E81</i>	Event 8 type	0			
30	<i>E82</i>	Event 8 stand-by	0			
31	<i>dLE</i>	Event on-delay time unit	0			0: s 1: min  <div style="border: 1px solid black; padding: 2px; display: inline-block;">Supplement</div> Common to events 1 to 3. This function is not provided for other events than 1 to 3.
32	<i>r-tr</i>	RSP tracking	0			0: Not provided. 1: Provided.

Guide No.	Item code	Item	Set value at delivery from factory	User's setting column	Setting
33	<i>SPU</i>	LSP up ramp	0		0 to 26000U (0: Ramp not provided)
34	<i>SPd</i>	LSP down ramp	0		0 to 26000U (0: Ramp not provided)
35	<i>rSPU</i>	RSP up ramp	0		0 to 26000U (0: Ramp not provided)
36	<i>rSPd</i>	RSP down ramp	0		0 to 26000U (0: Ramp not provided)
37	<i>rR-E</i>	SP ramp unit setting	0		0: U/min      2: U/h 1: 0.1U/min    3: 0.1U/h  <b>Supplement</b> Common to LSP and RSP.
38	<i>gb-L</i>	Low limit of green belt	50U		0 to 200U
39	<i>gb-H</i>	High limit of green belt	50U		0 to 200U
40	<i>Π-C</i>	Selection of motor control method	0		0: MFB control (conventional type) + Presumed position control 1: MFB control (conventional type) only 2: Presumed position control (without MFB) only
41	<i>Π-RE</i>	Automatic motor adjustment	0		0: Non-adjustment 1: Adjustment start  <b>Supplement</b> When "1" is selected and the  key is pressed, the motor is fully closed, then it is fully opened, and the MFB value and time are automatically measured. To stop adjustment, press the  key.
42	<i>Π-CL</i>	Input with motor fully closed	1000		0 to (Input with motor fully closed – 500)
43	<i>Π-OP</i>	Input with motor fully open	9000		(Input with motor fully closed + 500) to 10000
44	<i>Π-E</i>	Motor full close – full open time	30.0		5.0 to 240.0s

Guide No.	Item code	Item	Set value at delivery from factory	User's setting column	Setting
45	<i>DP</i>	Indication 1 digit masking	0		<p>0: Not provided. 1: Provided.</p> <p><b>Supplement</b> Effective for PV, SP and DEV. However, it is not effective when an SP is set.</p>
46	<i>AT</i>	Selection of auto tuning (AT) system	0		<p>0: AT is not executed. 1: General AT is executed. 2: AT preventing overshoot is executed. 3: AT by neural net is executed. 4: In the internal cascade model, the slave side auto tuning is executed in the system 1 (general AT).</p>
47	<i>ST</i>	Selection of smart tuning system (overshoot suppression control)	0		<p>0: Smart tuning is not executed. 1: Overshoot is suppressed with brake value fixed. 2: Overshoot is suppressed, while rechecking the brake value automatically.</p>
48	<i>2PI d</i>	Selection of 2 freedom degrees PID	0		<p>0: 2 freedom degrees are not used. 1: 2 freedom degrees are used.</p>

Guide No.	Item code	Item	Set value at delivery from factory	User's setting column	Setting
49	9-r	Selection of gain/RSP multi ratio	0		0: Both are not used. 1: Variable gain is used. 2: RSP multi ratio is used. (only in remote SP and internal cascade models).
50	9n-1	Gain 1 (ratio 1)	1.00 (1.000)		<p>Gain Setting range: 0.01 to 300.00 Control gain to DEV:</p> <p>Gain 1: Gain in +20% FS Gain 2: Gain in +10% FS Gain 3: Gain in +5% FS Gain 4: Gain in +2% FS Gain 5: Gain in 0% FS Gain 6: Gain in -2% FS Gain 7: Gain in -5% FS Gain 8: Gain in -10% FS Gain 9: Gain in -20% FS</p> <p>Linear approximation is applied between individual points, and both ends are extended.</p> <p>Ratio Setting range: 0.001 to 30.000 Each ratio can be selected only by a remote switch.</p>
51	9n-2	Gain 2 (ratio 2)	1.00 (1.000)		
52	9n-3	Gain 3 (ratio 3)	1.00 (1.000)		
53	9n-4	Gain 4 (ratio 4)	1.00 (1.000)		
54	9n-5	Gain 5 (ratio 5)	1.00 (1.000)		
55	9n-6	Gain 6 (ratio 6)	1.00 (1.000)		
56	9n-7	Gain 7 (ratio 7)	1.00 (1.000)		
57	9n-8	Gain 8	1.00		
58	9n-9	Gain 9	1.00		

Guide No.	Item code	Item	Set value at delivery from factory	User's setting column	Setting
59	<i>t-A.1</i>	Input broken line approximation A1	0		<p>An: -19999 to 26000U Bn: -19999 to 26000U</p> <p><b>Supplement</b> An denotes the input axis, and Bn the output axis. For example, B1 is output with respect to A1 input. Linear correction is applied between individual points, and both ends are fixed at (-20000U, -20000U) and (26000U, 26000U).</p> <p>It is selected by C72 whether this parameter is used for A11 or A12.</p> <p>The input broken line approximation is applicable to all input types (T/C, RTD, mV, V and mA).</p>
60	<i>t-A.2</i>	Input broken line approximation A2	1000		
61	<i>t-A.3</i>	Input broken line approximation A3	1000		
62	<i>t-A.4</i>	Input broken line approximation A4	1000		
63	<i>t-A.5</i>	Input broken line approximation A5	1000		
64	<i>t-A.6</i>	Input broken line approximation A6	1000		
65	<i>t-A.7</i>	Input broken line approximation A7	1000		
66	<i>t-A.8</i>	Input broken line approximation A8	1000		
67	<i>t-A.9</i>	Input broken line approximation A9	1000		
68	<i>t-A.A</i>	Input broken line approximation A10	1000		
69	<i>t-A.b</i>	Input broken line approximation A11	1000		
70	<i>t-b.1</i>	Input broken line approximation B1	0		
71	<i>t-b.2</i>	Input broken line approximation B2	1000		
72	<i>t-b.3</i>	Input broken line approximation B3	1000		
73	<i>t-b.4</i>	Input broken line approximation B4	1000		
74	<i>t-b.5</i>	Input broken line approximation B5	1000		
75	<i>t-b.6</i>	Input broken line approximation B6	1000		
76	<i>t-b.7</i>	Input broken line approximation B7	1000		
77	<i>t-b.8</i>	Input broken line approximation B8	1000		
78	<i>t-b.9</i>	Input broken line approximation B9	1000		
79	<i>t-b.A</i>	Input broken line approximation B10	1000		
80	<i>t-b.b</i>	Input broken line approximation B11	1000		

### 5-3 Detailed Description of Parameter Items

(Figure in brackets [ ] denotes a set value at delivery from the factory.)

1: *rn.rY* RUN/READY selection [ *rdY* ]

RUN means the usual control status. In READY, control operation is stopped, and the quantity set by C28, 27 is output as a control output. It can be selected by C28 whether an event is operated or not even in the READY mode. Setup items cannot be changed in any other status than READY, except for key lock selection C1. However, when setup items have been registered in the UF keys, they can also be changed even in the READY status.

2: *FL* AI1 filter [0.0]

0.0 to 120.0s (no filter is provided at 0.0)

A primary delay digital filter can be applied to AI1 (analog input 1).

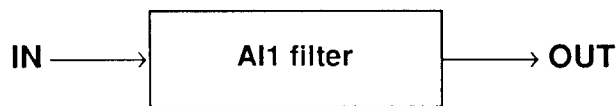

$$OUT = OUT_{-1} + (IN - OUT_{-1}) / (T/Ts + 1)$$

IN : Input to AI1 filter

OUT : Current filter operation output

OUT<sub>-1</sub> : Previous filter operation output

T : Filter set value (s)

Ts : Sampling cycle (0.1s)

3: *rR* AI1 ratio [1.000]

0.001 to 9.999

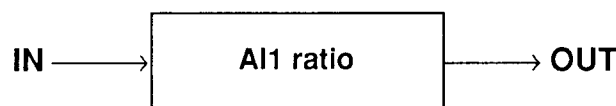

$$OUT = IN \times \text{Ratio set value}$$

4: *bI* AI1 bias [0]

-1000 to 1000U



$$OUT = IN \times \text{Bias set value}$$

Bias operation is executed after ratio operation is made.



10: *outL* Control output variation limit [0.0]  
 0.0 to 10.0% (updated every 0.1s. No limit is provided at 0.0)

This variation limit is applied after PID operation in the standard model or remote SP model, or after PID operation of the master controller in the internal cascade model. When the mode is switched from RUN to READY, or from AUTO to Preset Manual, or the control output is transferred to the fixed MV value 1, 2, 3, this variation limit functions so that the limit set value is used in each direction of increase and decrease instead of the output (%) variation after operation, if the latter is greater than the former. The example shown below shows how the actual manipulated variable changes when the manipulated variable is changed from 20% to 22% with the variation limit set to 0.5%. The output is increased by 0.5% every 0.1s and it reaches 22% after 0.4s.

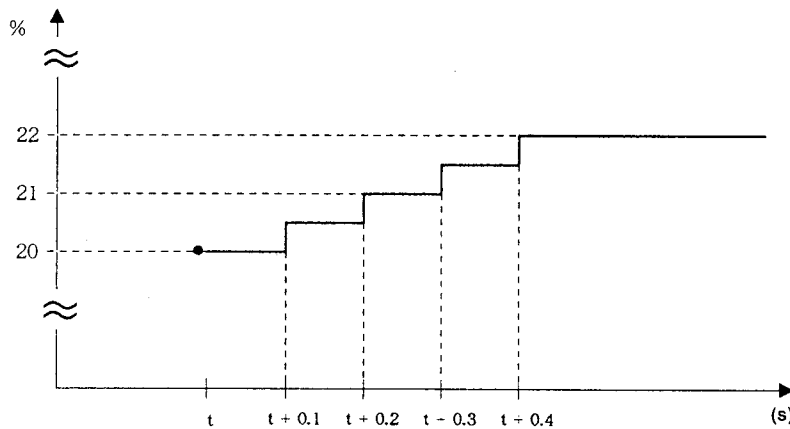

11: *outr* Control output variation limit [0.0]  
 0.0 to 10.0% (updated every 0.1s No limits is provided at 0.0)

This variation limit is applied after PID operation of the slave side controller is made in the internal cascade model. The applying manner is the same as in [ *outL* ].

12: *lout* Initial manipulated variable in PID operation at power on [ 0 ]  
 0 to 100%

PID operation starts with this initial manipulated variable when the PID operation in the standard model or remote SP model, or the PID operation of the master controller in the internal cascade model meets the following condition.

- When the power supply is turned on in the AUTO and RUN modes.
- When the READY mode is switched to the RUN mode in the AUTO mode.

The initial manipulated variable of PID operation of the slave controller is fixed (50.0%) in the internal cascade model.

13: *rPid* PID operation initialize at SP change [ 0 ]  
 0: Initialize decision is executed automatically.  
 1: Initialized at each time of SP change and SP write.  
 2: Not initialized at each time of SP change and SP write.  
 (SP change includes LSP ↔ RSP.)

In particular, this selection is done to prevent the PID operation output from being increased excessively by derivative action when an SP is changed. When this parameter is set to [0], decision is automatically executed mainly according to the magnitude of the absolute value deviation between a new SP and PV. When this deviation is small to a certain extent, initialize is not executed.

As for [PID operation initialize], the case of mode transfer is included in addition to the above-mentioned [ *lout* ] and [ *rPid* ]. Namely optimum initialize processing is executed internally when:

- MANUAL is changed over to AUTO in the RUN mode.
- The PID group number is changed from the console during selection in the RUN mode.

(When PID group number is not changed by a remote switch, initialize is not executed. When each set value of P, I and D is changed, initialize is not executed.)

14: *diff* Differential (The contents changes, depending up the type, as shown below.)

① Differential gap at on-off control	[50U]	<span style="border: 1px solid black; padding: 2px;">0D, 6D type</span>
0 to 1000U		
② Dead zone at position proportional control	[5.0]	<span style="border: 1px solid black; padding: 2px;">2G type</span>
0.5 to 25.0%		
③ Dead zone at heat/cool control	[0.0]	<span style="border: 1px solid black; padding: 2px;">Heat/cool</span>
-100.0% to 50.0%		

① Differential gap at on-off control

In the 0D and 6D types, on-off control is executed when P = 0, and the differential gap at that time is set.

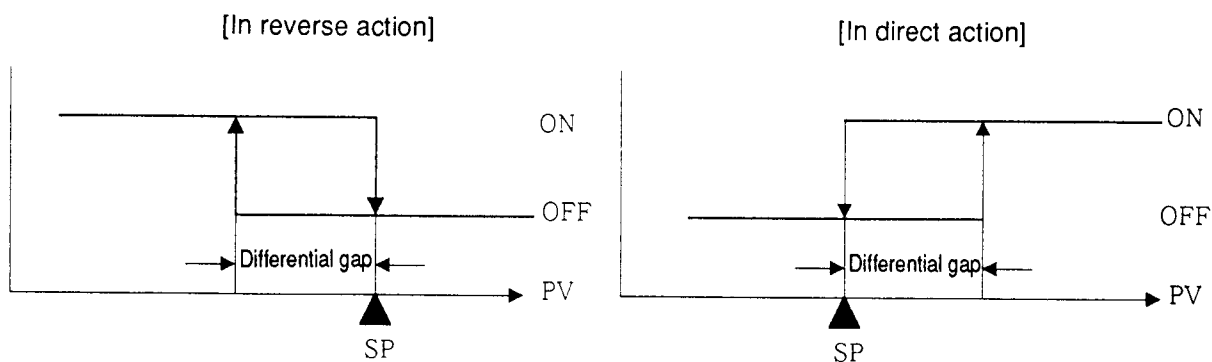

② Dead zone at position proportional control

In the 2G type, the dead zone between motor open and motor close is set. As setting reference, send the constant manual output, and change the dead zone until motor hunting stops. This is a minimum value of the dead zone. However, setting of a critical value may cause the life of the motor to be shortened extremely since the motor is always operated. Set this parameter value with the 5% at delivery used as reference, considering the control result and motor life.

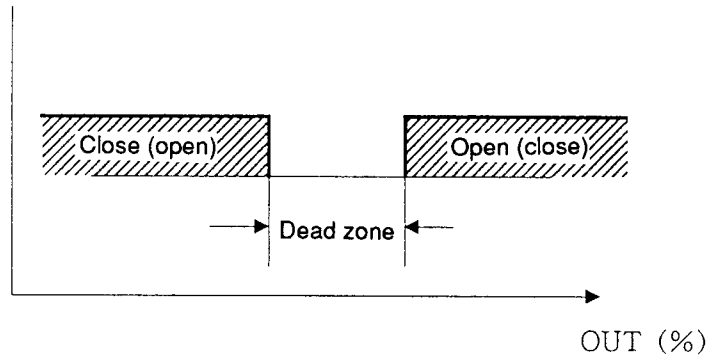

③ Dead zone at heat/cool control

In the heat/cool type, set the dead zone from the relation between the heat side output and cool side output with respect to the result of PID operation.

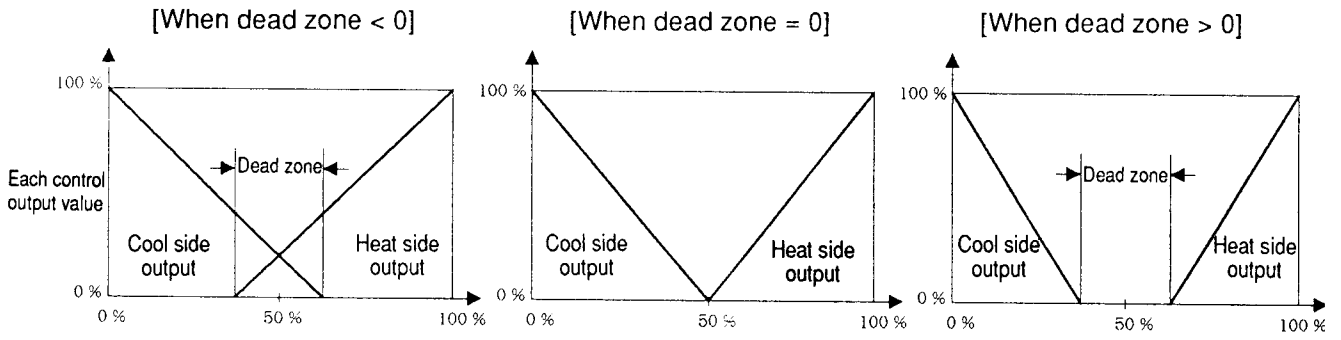

**Results of internal PID operation**

15:	<i>EEI</i>	Event 1 type
16:	<i>EdI</i>	Event 1 stand-by
	┌   └	┌   └
29:	<i>EEB</i>	Event 8 type
30:	<i>EdB</i>	Event 8 stand-by

These parameters are used to select each event type, and designate whether or not it is provided with a stand-by sequence. The set value and differential gap of an event, and the event on delay time of event 1 to 3 are set by EV setting (page 9-10). When the number of events is determined by the model number, more events cannot be set.

For the event types and assignment numbers, see the next page.

As for the events (direct deviation, reverse deviation, absolute value deviation, direct SP, and reverse SP) related with an SP or RSP, event occurrence processing is executed on the base of the value of varying SP (RSP).

As for the motor feedback (MFB) event, event occurrence processing is executed, using the presumed value of position presumption under execution.

Note that this event may occur at a position other than the actual angle of the motor.

A process alarm (process diagnosis event) is an event to detect the case where a PV does not move in the control direction of the controller. This cannot be activated in other than the event 1 to 3. Definitely, a process alarm is produced when the following three conditions are satisfied.

- 1) A manipulated variable exceeding the set output value (0 to 100%) of the event is output.
- 2) A PV does not rise (fall in direct action) beyond the differential gap of the event.
- 3) The above-mentioned status continues for longer than the on delay time of the event.

For the stand-by, either 0: stand-by not provided or 1: stand-by provided is selected. When the stand-by provided, it is reset if the event is turned off after the power supply is turned on or the READY mode is changed over to the RUN mode. Thus, the same action as the stand-by is not provided is performed subsequently.

31:	<i>dLE</i>	Event on delay time unit	[ 0 ]
		0: s	
		1: min	

The event on delay time unit is set in common to the events 1 to 3. This function is not provided for the events 4 to 8. This parameter cannot be set when the contents of assignment are 14 to 21 and 34.

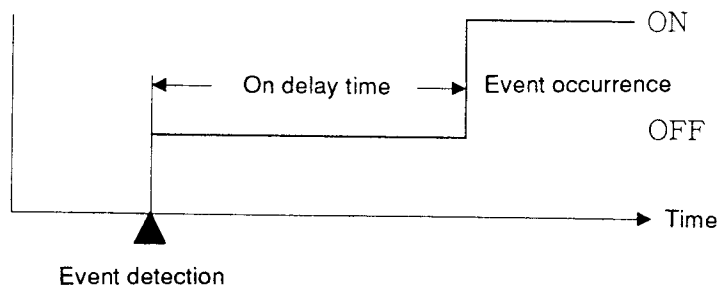

[Contents of event type assignment]

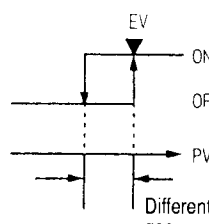
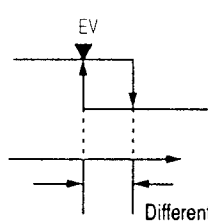
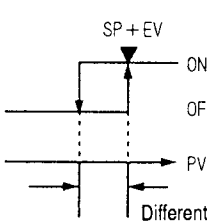
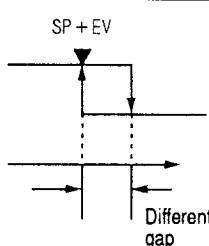
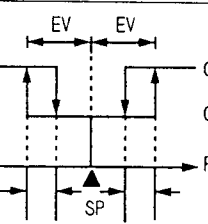
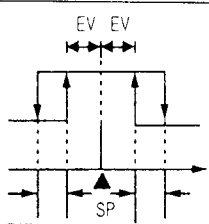
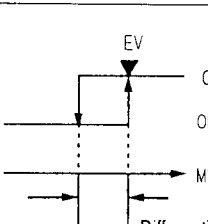
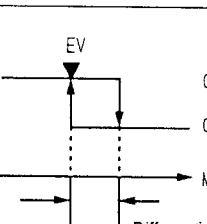
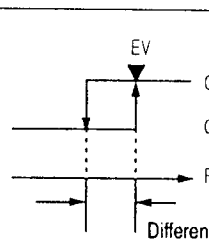
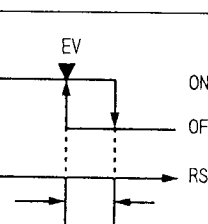
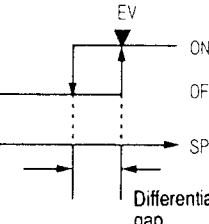
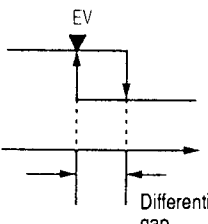
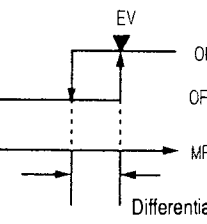
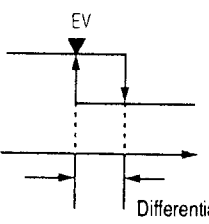
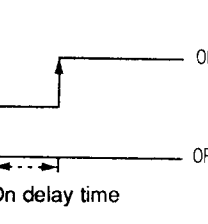
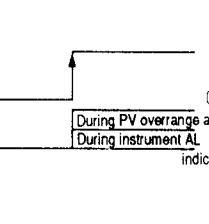
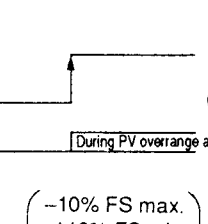
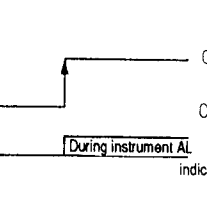
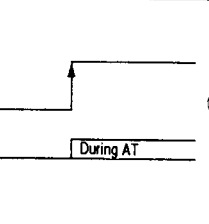
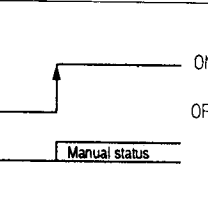
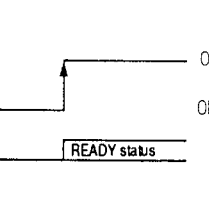
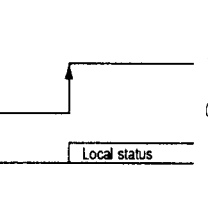
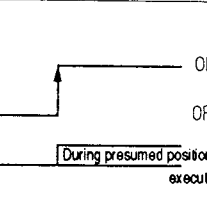
<p>0: Direct PV 22: Direct PV2</p> 	<p>1: Reverse PV 23: Reverse PV2</p> 	<p>2: Direct deviation 24: Direct deviation PV2</p> 	<p>3: Reverse deviation 25: Reverse deviation PV2</p> 	<p>4: Direct absolute deviation value 26: Direct absolute deviation value PV2</p> 
<p>5: Reverse absolute deviation value 27: Reverse absolute deviation value PV2</p> 	<p>6: Direct MV 28: Direct MV2</p> 	<p>7: Reverse MV 29: Reverse MV2</p> 	<p>8: Direct RSP 32: Direct internal RSP</p> 	<p>9: Reverse RSP 33: Reverse internal RSP</p> 
<p>10: Direct SP 30: Direct SP2</p> 	<p>11: Reverse SP 31: Reverse SP2</p> 	<p>12: Direct motor feedback (MFB)</p> 	<p>13: Reverse motor feedback (MFB)</p> 	<p>*1 14: Process alarm</p>  <p>On delay time</p>
<p>15: All alarm sum</p> 	<p>16: PV range alarm</p>  <p>(-10% FS max.) (+110% FS min.)</p>	<p>17: Instrument alarm (except for PV range alarm)</p> 	<p>18: Auto tuning status</p> 	<p>19: Manual status</p> 
<p>20: READY status</p> 	<p>21: Local status</p> 	<p>34: Presumed position execution status</p> 	<p>*1. Contents of process alarm</p> <p>This alarm is issued if a PV is kept <u>unchanged some time</u> after, although a manipulated variable exceeding <u>the set output</u> is sent. This is effective in EV1 to 3.</p> <ul style="list-style-type: none"> <li>• Set output = EV set value</li> <li>• Some time = EV on delay time</li> <li>• PV change = EV differential gap</li> </ul>	

32: *r-Lr* RSP tracking [ 0 ]  
 0: Not provided  
 1: Provided.

When "1" (provided) is selected, the current RSP value is written as an LSP during selection of LSP from RSP. When 8 LSPs are set in the LSP setting system of C16, the current RSP value is written in the LSP of the number selected at that time.

Even in the internal cascade model, the I-RSP value is written in S-LSP at that time.

33: *SPU* LSP up ramp [0U]  
 (SP1/main side in the internal cascade model)  
 0 to 26000U (ramp is not provided at 0U)

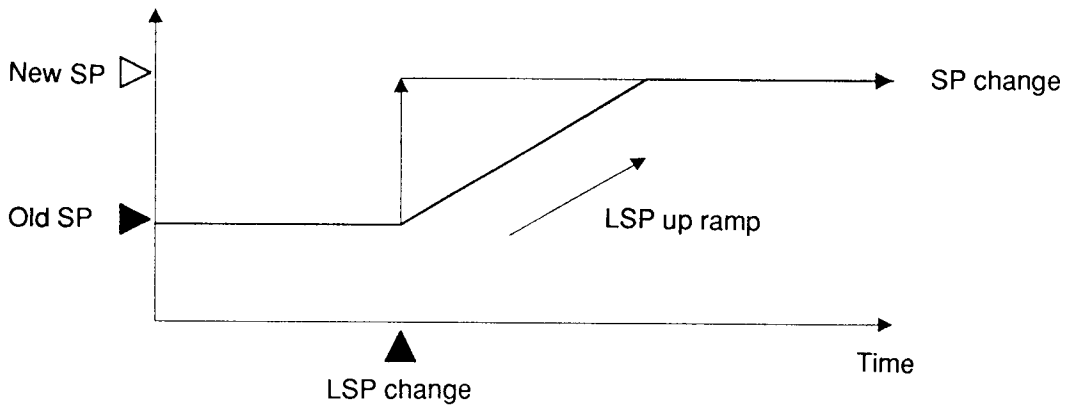

In the following case, PV tracking action is performed, using the present PV value instead of the old SP.

- When the power supply is turned on.
- When READY is changed to RUN.
- When MANUAL is changed to AUTO.

34: *SPd* LSP down ramp [0U]  
 (SP1/main side in the internal cascade model)  
 0 to 26000U (ramp is not provided at 0U)

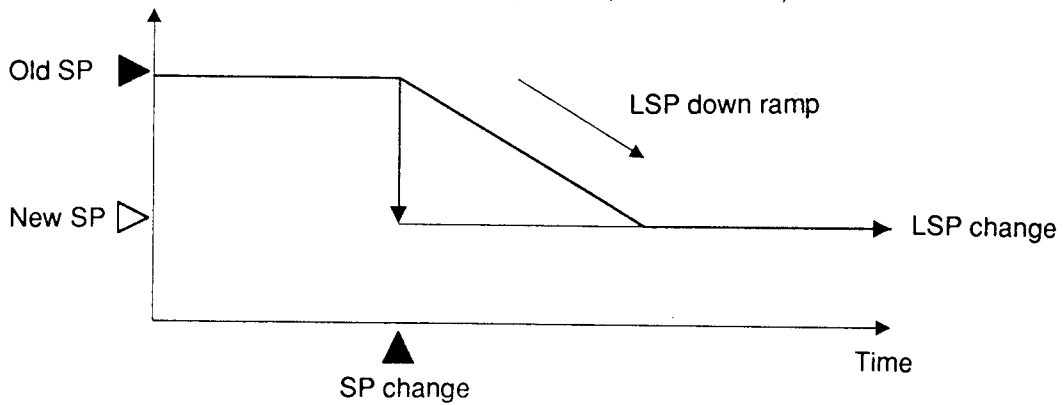

PV tracking action is executed with the same contents as *SPU*.

35: *rSPU* RSP up ramp [0U]  
(SP2/slave side in the internal cascade model)  
0 to 26000U

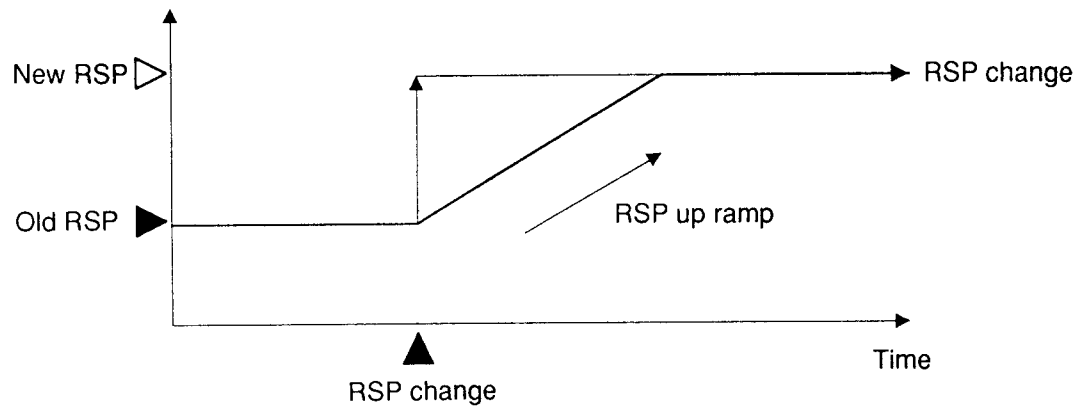

PV tracking action is executed with the same contents as *SPU*.

36: *rSPd* RSP down ramp [0U]  
(SP2/slave side in the internal cascade model)  
0 to 26000U

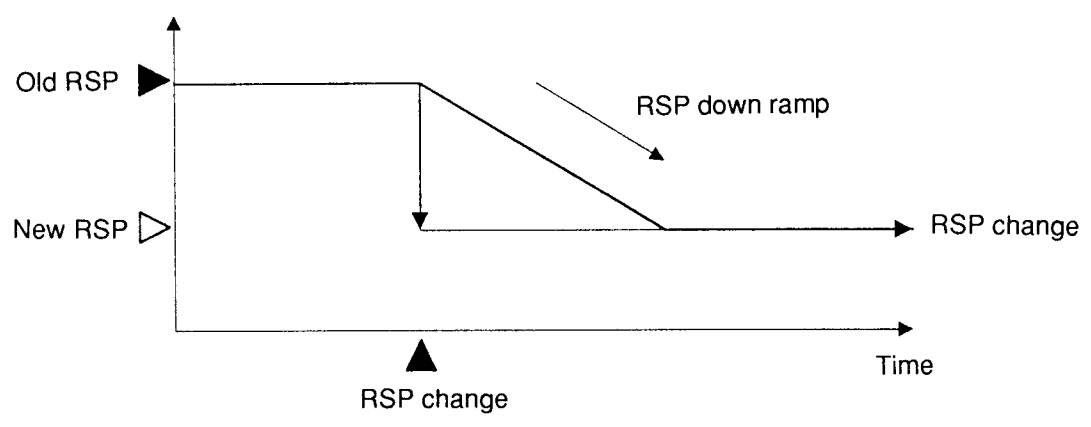

PV tracking action is executed with the same contents as *SPU*.

37: *rR-E* SP ramp unit setting [0]  
0: U/min  
1: 0.1U/min  
2: U/h  
3: 0.1U/h

This setting is effective in common to the LSP and RSP up/down set values. 0.1U means 1/10 of the minimum resolution of the relevant SP including the decimal point.

38:	<b>G. b. - L</b>	Low limit of green belt 0 to 200U	[50U]
39:	<b>G. b. - H</b>	High limit of green belt 0 to 200U	[50U]

These parameters set the high and low limits of stability when used as an OK lamp (C7=1) to monitor the control status of the instrument.

40:	<b>Π. - C</b>	Selection of motor control method 0: MFB control (conventional type) + Presumed position control 1: MFB control (conventional type) only 2: Presumed position control (without MFB) only	[ 0 ]
-----	---------------	---	-------

**[0]: MFB control + Presumed position control**

- When the MFB (Motor Feed Back) input is normal, the motor position is controlled by MFB being measured. While an MFB value is indicated in No. 2 indicator (lower stage), [**Fb**] lights in No. 3 indicator (FUNC).
- If the MFB input is abnormal, the motor position is controlled by the presumed MFB value. This status is called a presumed position control status. While an MFB value is indicated in No. 2 indicator, [**Fb**] flashes in No. 3 indicator. For example, if the motor rotates to a deterioration position of the motor feedback potential, the MFB input changes suddenly. This sudden change is detected as an error, and the proper position of MFB is presumed. Even when an MFB disconnection alarm occurs, the motor position is controlled by the presumed MFB value.
- In the presumed position control status, an error between the actual opening of the motor and the presumed MFB value is increased step by step unavoidably. Therefore, the close side relay is normally turned on when MV (output) ≤ 0.0%, and the open side relay is normally turned on when MV ≥ 100.0 to correct an error in the fully closed status or fully open status of the motor. However, if MV is controlled within the range of 0.1 to 99.9% by an output limiter, or MV is neither 0.0% or less, nor 100.0% or more according to a control status, this correction cannot be done.
- Even in the presumed control status, an event, auxiliary output and others are calculated on the base of a presumed MFB value.
- The following causes for setting of a presumed position control status are considered:
  - The motor opening adjustment is incomplete.
  - the deterioration resolution of feedback potential is insufficient.
  - MFB connection is wrong.

**[1]: MFB control (conventional type)**

- The motor control method used conventionally. When an MFB disconnection alarm occurs, the MFB value is regarded as 150.0% and the closed side relay is normally turned on.

**[2]: Presumed position control (without MFB)**

- The presumed position control is normally used as a motor control method. The motor position is controlled by the presumed MFB value regardless of MFB connection.





- Error processing in automatic adjustment
    - If MFB is disconnected, [15000] is written in each case of full close and full open.
    - In the primary case, the normal end is not executed as error processing, but the set values at delivery from the factory are restored, and "AL2" is indicated. "AL2" is cleared only when the automatic adjustment repeated again ends normally or the power supply is reset.
- [ (Full close count) – (Full open count) < 500 ]  
 [ (Full close count) > (Full open count) ]  
 [The time required from full close to full open is less than 5 sec.]  
 [MFB disconnection alarm (AL10, AL11) occurs continuously or frequently.]  
 [The time required until the MFB count value is stabilized exceeds 5 min.]  
 [Misconnection of MFB or open/close relay] (However, all misconnections cannot be detected as errors.)

42:	$\Pi$ -CL	Input with motor fully closed 0 to (Input with motor fully open – 500)	[1000]
43:	$\Pi$ -OP	Input with motor fully open (Input with motor fully closed + 500) to 10000	[9000]
44:	$\Pi$ -t	Motor full close – full open time 5.0 to 240.0 s	[30.0]

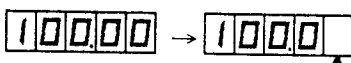

The above-mentioned three items are required to be set when the motor is adjusted manually. When [  $\Pi$ -C ] is "0" or "1" (MFB control is effective), all the three items can be set. When [  $\Pi$ -C ] is "2" (there is no MFB control), only the time of [  $\Pi$ -t ] can be set. In particular, when [  $\Pi$ -C ] is "2", the set time is used as the base for all operations. Measure the motor full close – full open time as accurately as possible up to the until of 0.1s and input the resultant value.

45:	dP	Indication 1 digit masking 0: Not provided. 1: Provided.	[ 0 ]
-----	----	--	-------

In the basic indication status, the least significant digit of each of PV, SP, DEV, RSP, PV2, SP2, and DEV2 is cleared from the LED indication.

Example:  →  Blank

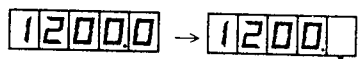
However, when this function is applied to an indication that includes one decimal digit as shown below, the decimal point cannot be erased because it is annexed to one digit.

 →  Blank

46:

Selection of auto tuning (AT) system

[ 0 ]

- 0: AT is not executed.
- 1: General AT is executed.
- 2: AT preventing overshoot is executed.
- 3: AT by neural net is executed.
- 4: In the internal cascade model, the slave side auto tuning is executed in the system 1 (general AT).

- In the auto tuning, the dead time and limit sensitivity of that system are found in any case by two limit cycles (with OL and OH of the selected current PID group used as a low limit and a high limit, respectively), and the PID values, etc. are calculated from their suitable characteristic expressions, and then the results are written. Auto tuning cannot be applied to all the heat/cool models in the standard model and remote SP model, or to the slave side of the heat/cool model in the internal cascade model (it can be applied to its master side as in the standard model, or the like). In the 0D and 6D models, the low limit output is 0%, and the high limit output is 100%.
- A PV fluctuates, depending upon an MV variation, during the execution of auto tuning. Before executing the auto tuning, make sure that the system does not cause an error due to this PV variation. Particularly, in the 5G and 2G models, the variation width of that PV can be limited by the OL and OH of a selected PID group. Therefore, in such a system that a large variation in PV is undesirable, set OL and OH near the expected design output at the set values to execute the auto tuning.
- Usually, suitable values are written by selecting "1" or "3" for this parameter. However, in a system which is liable to cause an overshoot, select "2" or use together the smart tuning for overshoot suppression control. When "3" is selected here, processing is executed by the neural net so that suitable values can be found for a wider range of applications as compared with the selection of "1" and "2". For the internal cascade model, first execute the auto tuning of the slave side in the local status by selecting "4", then execute that of the master side in the remote status by selecting any of "1" to "3".
- The output inversion (low limit ↔ high limit) points in auto tuning are determined from the SP and PV at the AT start as shown below. The SP at the AT start includes RSP, SP under ramp, and LSP shift as well.

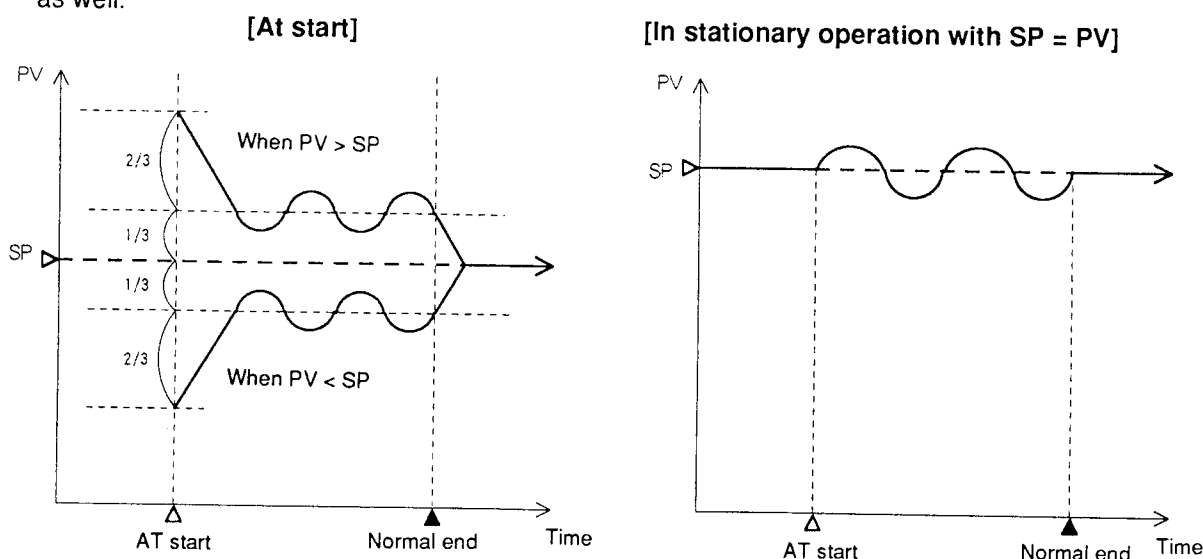



48: **2PI d**

Selection of 2 freedom degree PID

0: 2 freedom degrees are not used.

1: 2 freedom degrees are used.

- The 2 freedom degree PID function enhances the response to disturbance at setting without affecting the conventional rise (or fall) characteristic adversely. When the system "1" is selected, the optimum PID constants for response to disturbance can be set individually in addition to the conventional PID constants. These constants are set and stored automatically during the execution of auto tuning, and they can also be set and changed individually. In particular, when an MV variation is to be suppressed during setting in the 2G model to lessen the operation frequency of the motor and prolong its life, this function is effective by weakening the derivative of the PID for disturbance manually.
- These two kinds of PID can be changed over to each other manually by controlling the deviation and PV ramp, using the fuzzy rule.
- When I = 0 is set, the control action is executed without integral control action in any status regardless of the set value of dI for disturbance. In case of on-off control of P = 0.0, the disturbance response control cannot be selected.

49: **G-r**

Selection of 2 gain/RSP multi ratio

[ 0 ]

0: Both are not used.

1: The variable gain is used.

2: The RSP multi ratio is used.

(in the remote SP and internal cascade models only)

- It is selected whether either the variable gain or the RSP multi ratio (IRSP multi ratio in the internal cascade model) is to be set during setting of the parameters 50 to 58 given below. However, in case of the multi ratio, the number of settable ratios is seven, and they can be set only in the parameters 50 to 56.
- The gain has the same meaning as the inverse number of the proportional band P. When its numeric is increased, the sensitivity is enhanced, and the controllability is improved, but hunting is liable to be produced. When its numeric is reduced on the contrary, the sensitivity becomes dull.

$$\text{Real proportional band} = \text{Set proportional band} \times \frac{1}{\text{Gain value}}$$

- Any of the nine gain values [ **Gn-1** ] to [ **Gn-9** ] can be set according to the deviation width. For the real gain application, a value on the linear line connecting between the individual set points is used to smooth the control action. The gain at -20% is applied to a deviation of -20% max., and that at +20% is applied to a deviation of +20% min.

$$\text{Deviation} = \frac{\text{PV} - \text{SP}}{\text{Input range}} \quad (\text{reverse action})$$

$$\text{Deviation} = \frac{\text{SP} - \text{PV}}{\text{Input range}} \quad (\text{direct action})$$

- Example of broken line of gain :

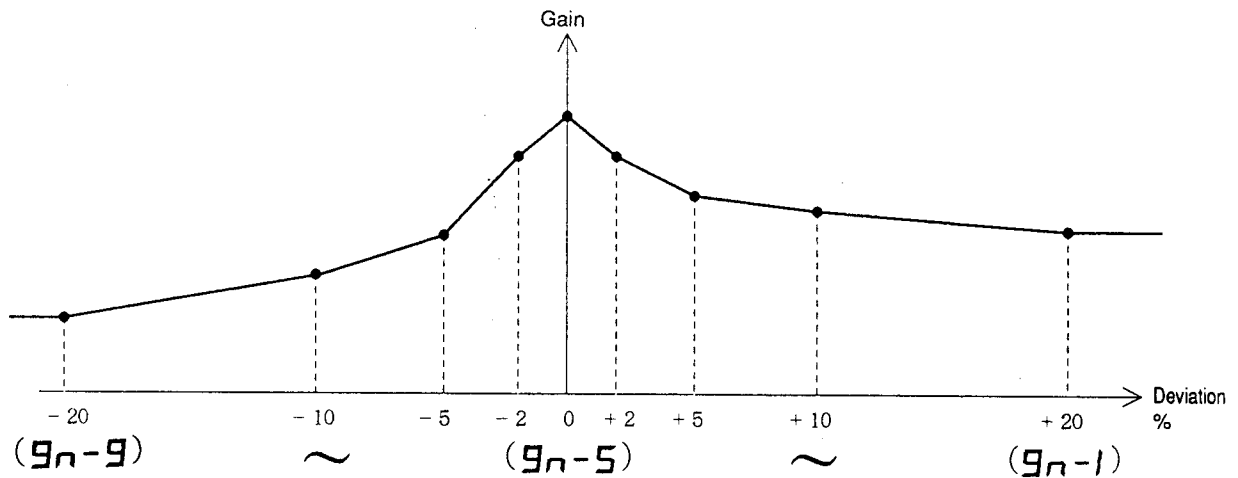

An abnormal point may be produced in the real proportional band and thereby the control action may be disturbed, depending upon the set value of gain, and the set proportional band. Therefore, be careful when the large set width of gain is to be selected.

- As for the RSP multi ratio, the following simple multiplication formula is obtained concerning the RSP in the remote SP model, or IRSP in the internal cascade model.

$$Y = X \times \text{Ratio set value}$$

where, Y: RSP (or IRSP) used for actual control

X: RSP (or main side MV) which is input to AI2

- The RSP multi ratio can be selected only by a remote switch. Unless selected, the RSP multi ratio is operated as 1.000. Particularly, in the remote SP model, the AI2 ratio is then effective.

50 :	<del>gn-1</del>	Gain 1 / (ratio 1)	[1.00 / (1.000) ]
51 :	<del>gn-2</del>	Gain 2 / (ratio 2)	[1.00 / (1.000) ]
52 :	<del>gn-3</del>	Gain 3 / (ratio 3)	[1.00 / (1.000) ]
53 :	<del>gn-4</del>	Gain 4 / (ratio 4)	[1.00 / (1.000) ]
54 :	<del>gn-5</del>	Gain 5 / (ratio 5)	[1.00 / (1.000) ]
55 :	<del>gn-6</del>	Gain 6 / (ratio 6)	[1.00 / (1.000) ]
56 :	<del>gn-7</del>	Gain 7 / (ratio 7)	[1.00 / (1.000) ]
57 :	<del>gn-8</del>	Gain 8	[1.00 ]
58 :	<del>gn-9</del>	Gain 9	[1.00 ]

Gain set range : 0.01 to 300.00

Ratio set range: 0.001 to 30.000

59 :	$t-A.1$	Input broken line approximation A1	[ 0 ]
60 :	$t-A.2$	Input broken line approximation A2	[1000 ]
	} }		}
69 :	$t-A.b$	Input broken line approximation A11	[1000 ]
70 :	$t-b.1$	Input broken line approximation B1	[ 0 ]
71 :	$t-b.2$	Input broken line approximation B2	[1000 ]
	} }		}
80 :	$t-b.b$	Input broken line approximation B11	[1000 ]
		An set range : -19999 to 26000U	
		Bn set range : -19999 to 26000U	

- Broken line approximation can be applied to the analog. Select AI1 or AI2 to be applied by setup C72, and set the broken line itself in the parameter 59 to 80. An denotes the input axis, while Bn denotes the output axis. For example, B<sub>1</sub> is output with respect to A<sub>1</sub> input, and a linear interpolation is applied between individual points. Both ends are fixed at (-20000U, -20000U) and (26000U, 26000U), respectively.
- In the broken line approximation operation, the input and output are set directly not in percent but in industrial unit. When linear scaling is permitted, the values after scaling are input.

[Input broken line approximation concept diagram]

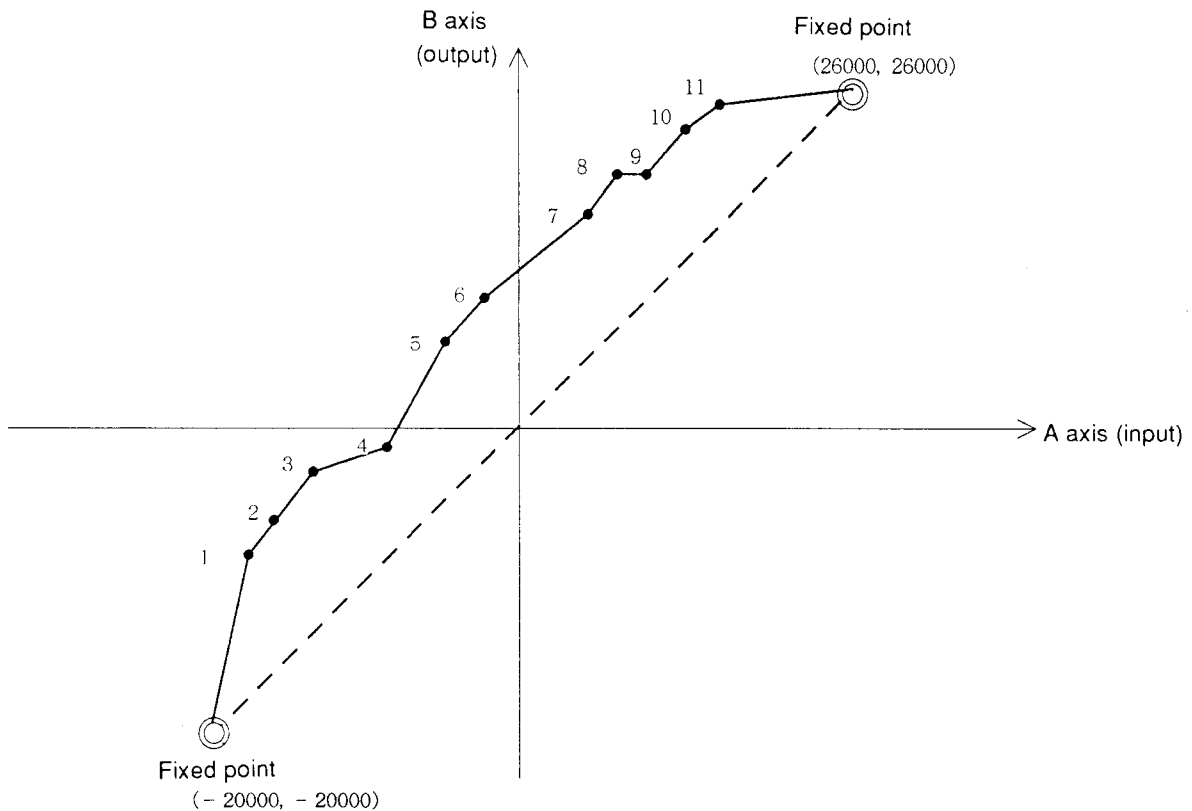

- Both  $A_n$  and  $B_n$  of a broken line are required to be set in the incremental direction as follows;

$$(A_1, B_1) = (0, 0), \quad (A_2, B_2) = (100, 100)$$

If a point on a broken line does not satisfy the incremental direction in its values, a broken line is produced with this point removed.

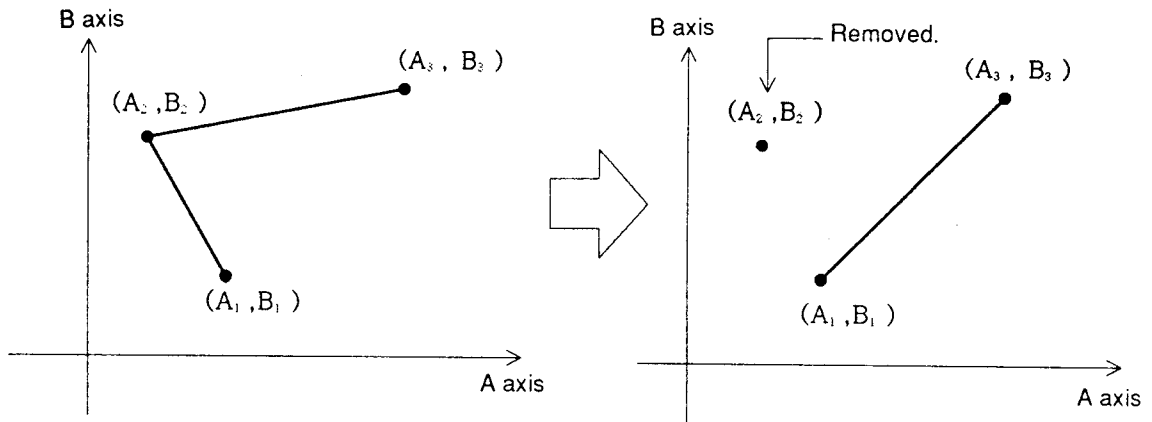

- If two points take the same value as to the A axis such as  $A_1 = A_2$ , the output value becomes  $B_1$ .

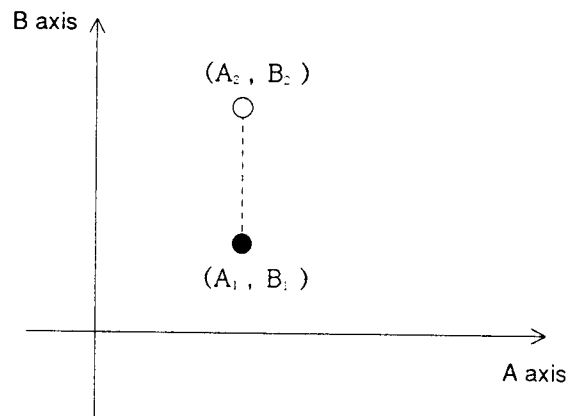

— MEMO —

# Chapter 6 SETTING OF PID ITEMS

## 6-1 PID Operation

### 1. Prior to setting

Up to eight PID groups can be set. Usually, the PID group assigned to the SP group is used in pair, but an arbitrary PID group can also be selected by a remote switch.

There are ten set items in one PID group; general PID, high and low limits of manipulated variable, manual reset, brake and PID for disturbance control. Although all set items can be set manually, the general PID and PID for disturbance control are found by the auto tuning, and stored automatically. When automatic rechecking setting for overshoot suppression is executed by the smart tuning, the brake value is also updated automatically according to the rise characteristic at every time. These tuning methods can be selected by setting the parameter Guide No. 46, 47 and 48.

### 2. How to set and reset the PID setting

The PID setting can be done in any mode (RUN/READY, AUTO/MAN and others) so far as the instrument is placed in the basic indication status.

In the basic indication status, a PV is indicated in No. 1 indicator, and an SP in No. 2 indicator. This status can be set by pressing the **DISP** key. Even when DEV or OUT is indicated in No. 2 indicator instead of the SP, the parameter setting mode can be set.

When the **PARA** key is pressed in the basic indication status, the following three setting groups can be called in turn. When the **ENT** key is pressed with **PID** indication, the PID item setting mode can be set.

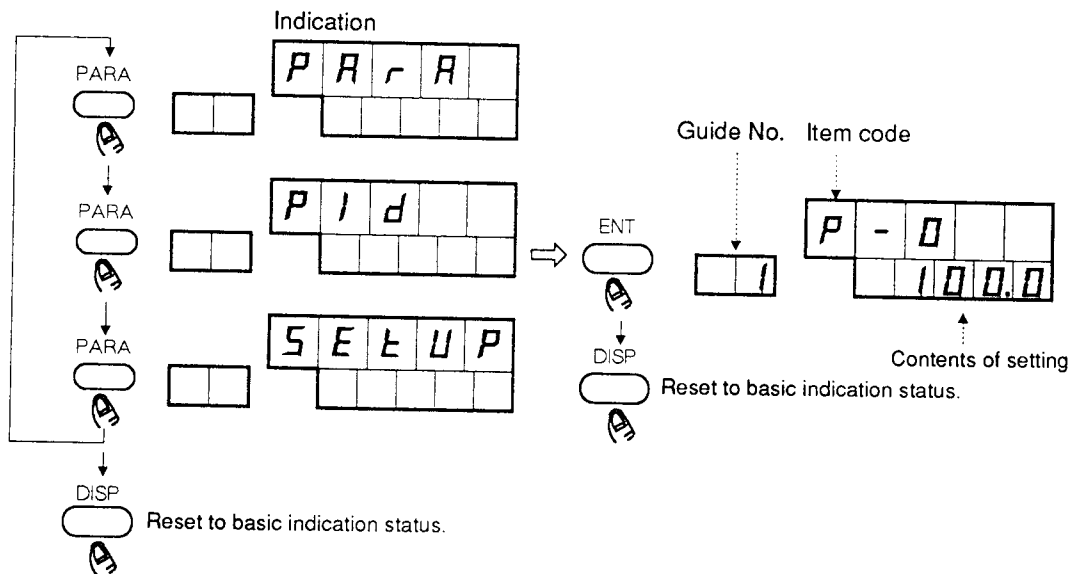



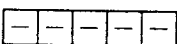

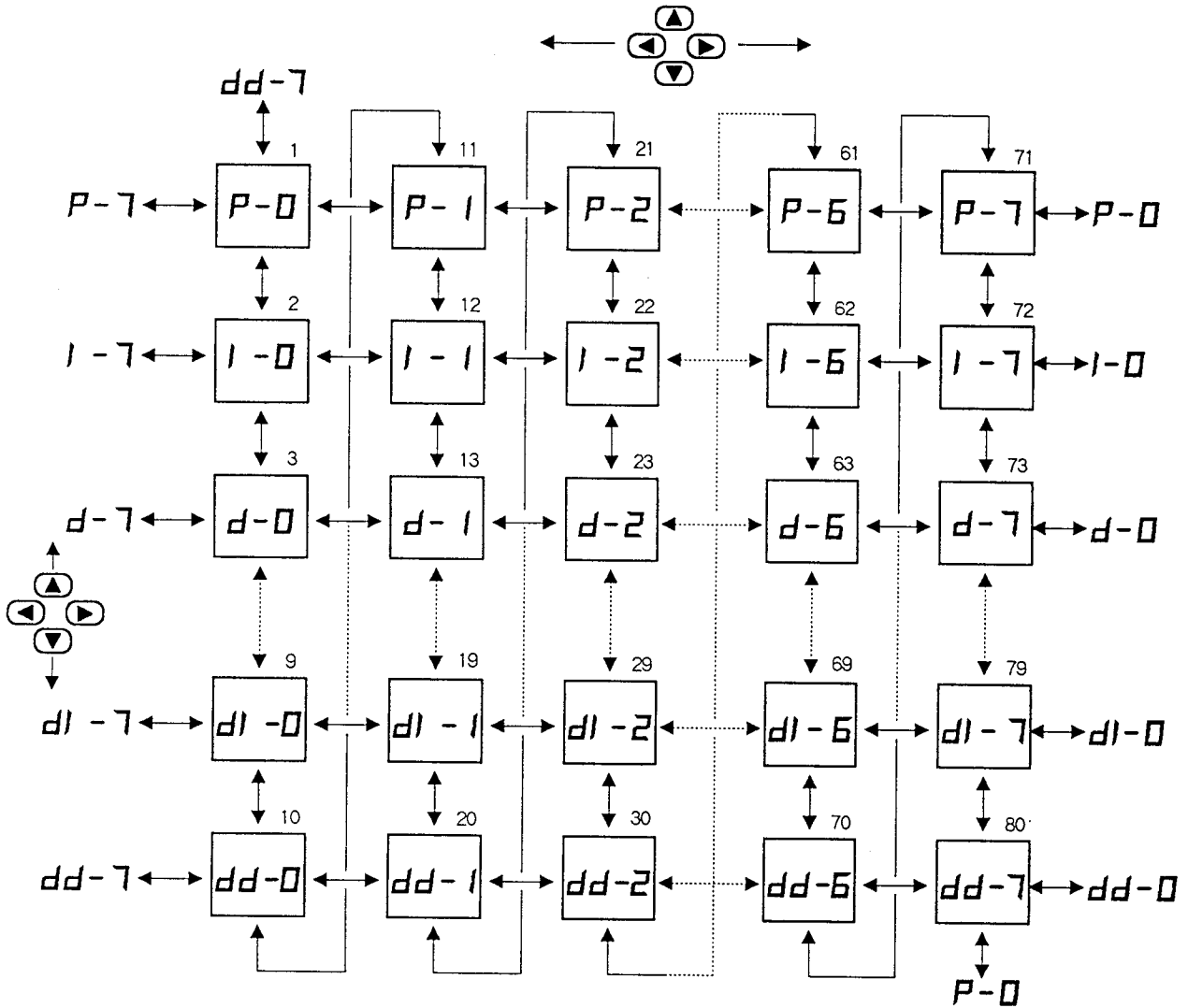
### 3. How to move the PID items

The PID items have a matrix construction like the two other setting groups. Each can be moved optionally with  keys as shown below. Unnecessary items are skipped, depending upon the model or the contents of setting.  is indicated in the No. 2 indicator for an unused item. The figure given at the right top of a frame of each item denotes Guide No.



### 4. How to change the set value of a PID item

To change the set value of a PID item, press the  key when this item is indicated. The set value on the No. 2 indicator flashes, indicating that it can be readily changed. Set a desired value with  keys, and press the  key. This value is stored, and flashing stops.

If the previous value is to be restored when the set value flashes, don't press the  key, but press the  key to reset to the basic indication status. Then, make the same setting operation.

## 6-2 PID Item Table

Guide No.	Item code	Item	Set value at delivery from factory	User's setting column	Setting
1	P-0	Proportional band	0	100.0	<p>Proportional band (P, dP): 0.0 to 1000.0% (0D, 6D), 0.1 to 1000.0% (5G, 2G, and 0D, 6D of heat/cool and internal cascade) In 0D and 6D, on-off control when set to 0.0. (dP is within 0.1 to 1000.0%)</p> <p>Integral time (I, dI): 0 to 3600s (dI is within 1 to 3600 sec). No integral action is provided at 0.</p> <p>Derivative time (d, dd): 0 to 1200s. No derivative action is provided at 0.</p> <p>Manual reset (rE): 0 to 100%. Indicated when P≠0 and I=0.</p> <p>Brake (br): 0 to 30. Brake function is stopped when set to 0. Overshoot suppression function is enhanced as numeric increases.</p> <p>Low-limit of manipulated variable (OL): -10% to high limit</p> <p>High-limit of manipulated variable (OH): Low limit to 110%</p> <p><b>Supplement</b></p> <ul style="list-style-type: none"> <li>This instrument has the two freedom degree PID control functions (selection). The optimum PID constants and the PID constants suitable for response to disturbance are set separately during setting change. It is automatically identified according to the current condition which PID constants are to be used, and automatic PID selection is executed by the instrument.</li> <li>PID constants for disturbance are also set automatically by auto tuning.</li> <li>If the numeric of the proportional band is made smaller, the controllability is enhanced, but an overshoot or hunting is liable to be produced, and the life of the actuator such as the modutrol motor may be shortened. Therefore, be careful not to make this value too small.</li> </ul>
2	I-0	Integral time	0	0	
3	d-0	Derivative time	0	0	
4	oL-0	Low-limit of manipulated variable	0	0	
5	oH-0	High-limit of manipulated variable	0	100	
6	rE-0	Manual reset	0	50	
7	br-0	Brake	0	0	
8	dP-0	Disturbance control proportional band	0	100.0	
9	dI-0	Disturbance control integral time	0	120	
10	dd-0	Disturbance control derivative time	0	0	
11	P-1	Proportional band	1	100.0	
12	I-1	Integral time	1	0	
13	d-1	Derivative time	1	0	
14	oL-1	Low-limit of manipulated variable	1	0	
15	oH-1	High-limit of manipulated variable	1	100	
16	rE-1	Manual reset	1	50	
17	br-1	Brake	1	0	
18	dP-1	Disturbance control proportional band	1	100.0	
19	dI-1	Disturbance control integral time	1	120	
20	dd-1	Disturbance control derivative time	1	0	
21	P-2	Proportional band	2	100.0	
22	I-2	Integral time	2	0	
23	d-2	Derivative time	2	0	
24	oL-2	Low-limit of manipulated variable	2	0	
25	oH-2	High-limit of manipulated variable	2	100	
26	rE-2	Manual reset	2	50	
27	br-2	Brake	2	0	
28	dP-2	Disturbance control proportional band	2	100.0	
29	dI-2	Disturbance control integral time	2	120	
30	dd-2	Disturbance control derivative time	2	0	

Guide No.	Item code	Item		Set value at delivery from factory	User's setting column	Setting
31	P-3	Proportional band	3	100.0		<ul style="list-style-type: none"> <li>• When a smaller numeric is set as the integral time, the follow-up ability is enhanced, but cycling, or the like is liable to be caused by the integral action.</li> <li>• <i>br</i>, <i>dP</i>, <i>dI</i>, and <i>dd</i> may not be indicated, unless selection is appropriate.</li> <li>• When a larger numeric is set as the derivative time, an overshoot or the like is easy to suppress, but hunting or the like is liable to be caused by quick response to a minor action. Generally, the appropriate derivative time in the normal temperature control is considered to be within 1/3 to 1/4 of the integral time. Since the derivative action tends to cause hunting or the like in the pressure or flowrate control, it is not done at all, or scarcely done in many cases.</li> <li>• As a larger numeric is set as the brake, the overshoot suppression effect is enhanced, but the rise time becomes longer on the contrary.</li> <li>• The high limit and low limit of manipulated variable not only restrict the control output, but also limit the output amplitude during auto tuning. These limit values have no effect in the manual mode. Even in the 0D, 6D and heat/cool models, the manipulated variable can be set within -10 to 110%. However, it is regarded as 0% between -10 and 0%, and as 100% between 100 and 110%.</li> <li>• PID No. 1 to 7 only can be selected by remote switches, but PID No. 0 cannot be selected by them. When all the contacts of the remote switches assigned are open, the PID number in pair with an SP is used.</li> <li>• When I=0 is set, control is executed without integral action at each time of rise, and response to disturbance irrespective of the set contents of dI.</li> </ul>
32	I-3	Integral time	3	0		
33	d-3	Derivative time	3	0		
34	oL-3	Low-limit of manipulated variable	3	0		
35	oH-3	High-limit of manipulated variable	3	100		
36	rE-3	Manual reset	3	50		
37	br-3	Brake	3	0		
38	dP-3	Disturbance control proportional band	3	100.0		
39	dI-3	Disturbance control integral time	3	120		
40	dd-3	Disturbance control derivative time	3	0		
41	P-4	Proportional band	4	100.0		
42	I-4	Integral time	4	0		
43	d-4	Derivative time	4	0		
44	oL-4	Low-limit of manipulated variable	4	0		
45	oH-4	High-limit of manipulated variable	4	100		
46	rE-4	Manual reset	4	50		
47	br-4	Brake	4	0		
48	dP-4	Disturbance control proportional band	4	100.0		
49	dI-4	Disturbance control integral time	4	120		
50	dd-4	Disturbance control derivative time	4	0		
51	P-5	Proportional band	5	100.0		
52	I-5	Integral time	5	0		
53	d-5	Derivative time	5	0		
54	oL-5	Low-limit of manipulated variable	5	0		
55	oH-5	High-limit of manipulated variable	5	100		
56	rE-5	Manual reset	5	50		
57	br-5	Brake	5	0		
58	dP-5	Disturbance control proportional band	5	100.0		
59	dI-5	Disturbance control integral time	5	120		
60	dd-5	Disturbance control derivative time	5	0		

Guide No.	Item code	Item		Set value at delivery from factory	User's setting column	Setting
61	<b>P-6</b>	Proportional band	6	100.0		<ul style="list-style-type: none"> <li>• In the internal cascade model, the PID groups 0 to 5 are assigned to the master control side, and the PID groups 6 and 7 to the slave control side (LSP6, LSP7, RSP), and then the brake and disturbance control PID cannot be set in the slave control side PID groups 6 and 7.</li> <li>• In the internal cascade model, on-off control cannot be done on both master and slave control sides. When P=0.0% is set, it is regarded as P=0.1% during action.</li> <li>• The set values of the PID group at delivery from the factory are as shown below. <ul style="list-style-type: none"> <li>– Standard model and remote SP model ----- Both LSP0 to 7 and RSP: No. 0</li> <li>– Internal cascade model ----- LSP0 to 5 (M – LSP): No. 0 LSP6, 7: No. 6 I-RSP: No. 7</li> </ul> </li> </ul>
62	<b>I-6</b>	Integral time	6	0		
63	<b>d-6</b>	Derivative time	6	0		
64	<b>oL-6</b>	Low-limit of manipulated variable	6	0		
65	<b>oH-6</b>	High-limit of manipulated variable	6	100		
66	<b>rE-6</b>	Manual reset	6	50		
67	<b>br-6</b>	Brake	6	0		
68	<b>dP-6</b>	Disturbance control proportional band	6	100.0		
69	<b>dI-6</b>	Disturbance control integral time	6	120		
70	<b>dd-6</b>	Disturbance control derivative time	6	0		
71	<b>P-7</b>	Proportional band	7	100.0		
72	<b>I-7</b>	Integral time	7	0		
73	<b>d-7</b>	Derivative time	7	0		
74	<b>oL-7</b>	Low-limit of manipulated variable	7	0		
75	<b>oH-7</b>	High-limit of manipulated variable	7	100		
76	<b>rE-7</b>	Manual reset	7	50		
77	<b>br-7</b>	Brake	7	0		
78	<b>dP-7</b>	Disturbance control proportional band	7	100.0		
79	<b>dI-7</b>	Disturbance control integral time	7	120		
80	<b>dd-7</b>	Disturbance control derivative time	7	0		

### 6-3 Detailed Description of PID Items

In the cases of the standard model and heat/cool model with RSP, the PID groups are selected as shown in the table below.

Setting of PID groups of LSP0 to 7 and RSP	PID group used for heat control	PID group used for cool control
No. 0	No. 0	No. 1
No. 1	No. 2	No. 3
No. 2	No. 4	No. 5
No. 3	No. 6	No. 7

In the cases of the internal cascade heat/cool model, the PID groups are selected as shown in the tables below.

Setting of PID group of LSP0 to 5	PID group used for master side control
No. 0 to 5	As set to the left.

Setting of PID groups of internal RSP and LSP6 to 7	PID group used for heat control	PID group used for cool control
Setting is disabled.	No. 6	No. 7

# Chapter 7 SETTING OF SETUP ITEMS

## 7-1 Setup Operation

### 1. Prior to setup

After this instrument is built in an equipment for the first time, it is necessary to set the basic operation conditions for this instrument such as the input ranges, control actions, remote switch inputs and event outputs according to the equipment using methods.

This chapter provides descriptions on the setting of these basic operation conditions, which is called "setup". If the instrument has already been built in the equipment, and the setup has been completed, its resetting is not necessary.

There are about 40 to 90 setup items, which change, depending upon the model. There are also such setup items that the values set at delivery from the factory can be used as they are. To complete the setup items properly with no error in a short time, it is recommended to decide the setup values in advance, using the user's setting column, and perform the actual setup operation.

### 2. How to set and reset the setup setting mode



To set the setup setting mode, the key lock must be set to "0" without fail. The set values cannot be changed in any other mode than the READY. In not the READY mode but the RUN mode, the indications can be checked, but the ENT key does not function. However, in any status, the first setup item C1 "key lock" operation only can be done.

Press the DISP key to reset to the basic indication status in which a PV and an SP are indicated. When this status has been already set, the above-mentioned operation need not be done.

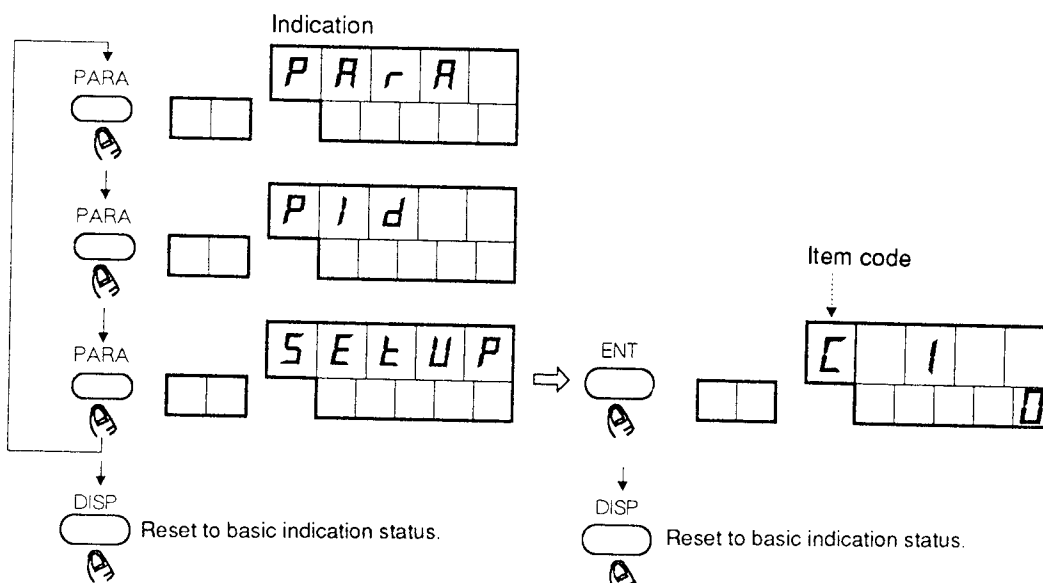
The following three setting groups can be called in turn by pressing the PARA key in the basic indication status. Press the ENT key with **SEtUP** indication to set the setup operation mode. Press the DISP key to reset the setup operation mode. In any status, the basic indication status can be restored.





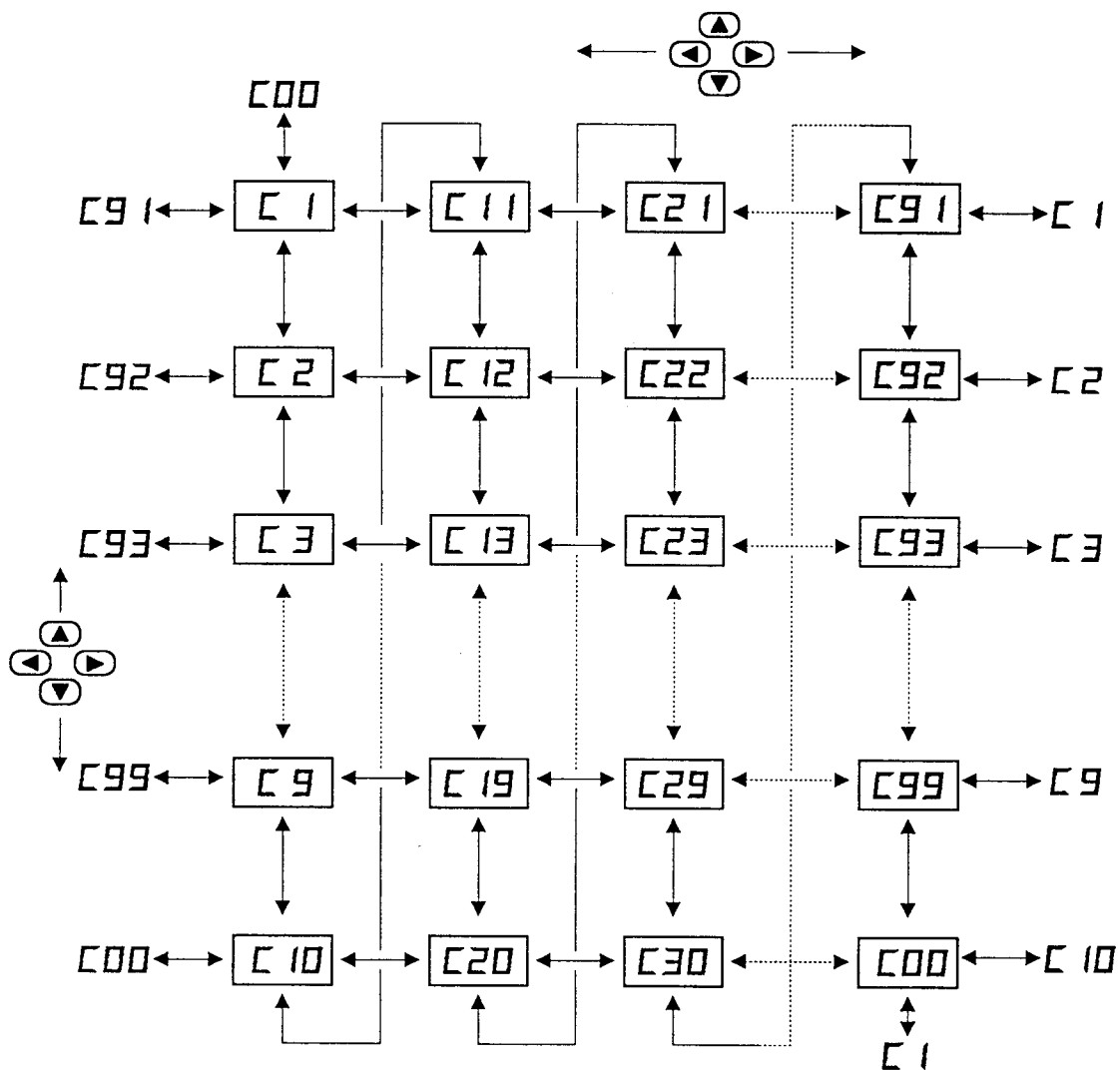

### 3. How to move a setup item

The setup items have a matrix construction like the two other setting groups. Each setup item can be moved optionally with  keys as shown below.  is indicated in the No. 2 indicator for an unnecessary item or unused item, depending upon the model or the contents of setting. The Guide No. is not indicated since it is the same as the setup item No.



### 4. How to change the set value of setup item

To change the set value of a setup item, press the  key, when this item is indicated. The set value on the No. 2 indicator flashes, indicating that it can be readily changed. Set a desired value with  keys, and press the  key. This value is stored, and flashing stops.

If the previous value is to be restored while the set value flashes, press not the  key, but press the  key to reset to the basic indication status. Then, make the same setting operation.

**7-2 Setup Item Table**

Guide No.	Item code	Item	Set value at delivery from factory	User's setting column	Setting
1	[ 1	Key lock	0		<p>0: Key lock is not provided.                      1: SETUP only cannot be changed, but the others can be changed.                      2: SETUP, PARA, and PID cannot be changed, but the others can be changed.                      3: SP/EV, SETUP, PARA and PID cannot be changed, but the others can be changed.                      4: DISP, UF1 and UF2 only can be changed, but the others cannot be changed.</p> <p><b>Supplement</b>                      The key lock itself can be changed in any status.</p>
2	[ 2	Control action (on the master side in the internal cascade model)	0		<p>0: Reverse action                      1: Direct action</p> <p><b>Supplement</b>                      Action change can be done by RSW.</p>
3	[ 3	Control action (on the slave side in the internal cascade model)	0		<p>0: Reverse action                      1: Direct action</p> <p><b>Supplement</b>                      Action change cannot be done by RSW.</p>
4	[ 4	Heat/cool output assignment	0		<p>0: Heat = MV1, Cool = MV2                      1: Heat = MV2, Cool = MV1</p>
5	[ 5	AI1 Temperature unit (analog input 1)	0		<p>0: °C                      1: °F</p>
6	[ 6	AI1 Input range type	0		<p>See the PV range number table (page 1-7, 1-8).</p> <p><b>Supplement</b>                      Full multi input type. However, the input connection must be changed, depending upon the input type.</p>