

Single Loop Controller SDC35/36 User's Manual "Installation"

Thank you for purchasing the SDC35/36. Before operating this product described in this User's Manual, please take note of the following points regarding safety. Be sure to keep this manual nearby for handy reference.

©2003 Yamatake Corporation ALL RIGHTS RESERVED

RESTRICTIONS ON USE

This product has been designed, developed and manufactured for general-purpose application in machinery and equipment. Accordingly, when used in applications outlined below, special care should be taken to implement a fail-safe and/or redundant design concept as well as a periodic maintenance program.

- Safety devices for plant worker protection
- Start/stop control devices for transportation and material handling machines
- Aeronautical/aerospace machines
- Control devices for nuclear reactors

Never use this product in applications where human safety may be put at risk.

This manual explains the handling precautions, mounting, wiring, PV range type, list of parameters and main specifications only. See the separate "Installation & Configurations" manual listed below for the detail handling procedures and the setting methods, etc. These manuals also contain information on using various functions. Please read if necessary.

Single Loop Controller SDC35/36 User's Manual
"Basic Operations" CP-SP-1150E
Smart Loader Package SLP-C35 for Single Loop Controller SDC15/25/
26/35/36 User's Manual CP-UM-5290E

Unpacking

Check the following items when removing the SDC35/36 from its package:

Name	Part No.	Q'ty	Remarks
Mounting Bracket	81409654-001	2	
User's Manual	CP-UM-5289E	1	This Manual

SAFETY PRECAUTIONS

- WARNING** Warnings are indicated when mishandling this product might result in death or serious injury to the user.
- CAUTION** Cautions are indicated when mishandling this product might result in minor injury to the user, or only physical damage to this product.

WARNING

- ! Note that incorrect wiring of the SDC35/36 can damage the SDC35/36 and lead to other hazards. Check that the SDC35/36 has been correctly wired before turning the power ON.
- ! Before wiring, or removing/mounting the SDC35/36, be sure to turn the power OFF. Failure to do so might cause electric shock or faulty operation.
- ⊘ Do not touch electrically charged parts such as the power terminals. Doing so might cause electric shock.
- ⊘ Do not disassemble the SDC35/36. Doing so might cause electric shock or faulty operation.

CAUTION

- ⊘ Do not operate the keys with a propelling pencil or sharp-tipped object. Doing so might cause faulty operation.
- ! Use the SDC35/36 within the operating ranges recommended in the specifications (temperature, humidity, voltage, vibration, shock, mounting direction, atmosphere, etc.). Failure to do so might cause fire or faulty operation.
- ⊘ Do not block ventilation holes. Doing so might cause fire or faulty operation.
- ! Wire the SDC35/36 properly according to predetermined standards. Also wire the SDC35/36 using specified power leads according to recognized installation methods. Failure to do so might cause electric shock, fire or faulty operation.
- ! Do not allow lead clippings, chips or water to enter the controller case. Doing so might cause fire or faulty operation.
- ! Firmly tighten the terminal screws at the torque listed in the specifications. Insufficient tightening of terminal screws might cause electric shock or fire.
- ⊘ Do not use unused terminals on the SDC35/36 as relay terminals. Doing so might cause electric shock, fire or faulty operation.
- ! We recommend attaching the terminal cover (sold separately) after wiring the SDC35/36. Failure to do so might cause electric shock.
- ! Use the relays within the recommended service life. Failure to do so might cause fire or faulty operation.
- ! Use Yamatake Corporation's "SURGENON" if there is the risk of power surges caused by lightning. Doing so might cause fire or faulty operation.

Mounting

Location

- Install the controller in the following locations:
- Common mode voltages of I/O except power supply and relay contact output: The voltage to ground is 33Vr.m.s max., 46.7V peak max., and 70Vdc max.
 - Not high or low temperature / humidity.
 - Free from sulfide gas or corrosive gas.
 - Less dust or soot.
 - Appropriately processed locations to prevent direct sunlight, wind or rain.
 - Less mechanical vibration and shock.
 - Not close to the high voltage line, welding machine or electrical noise generating source.
 - The minimum 15 meters away from the high voltage ignition device for a boiler.
 - Less effect by the magnetic field.
 - No flammable liquid or gas.

Mounting Procedure

- The mounting must be horizontal within 10 degrees tilted in back side lowering or within 10 degrees tilted in back side rising.
- The mounting panel should be used with a thickness of more than 2 mm of steel.

External Dimensions

- C35 (unit: mm)

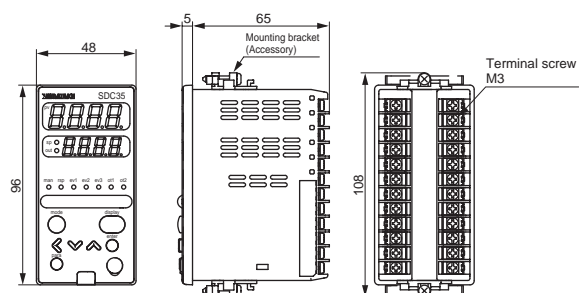

- C36

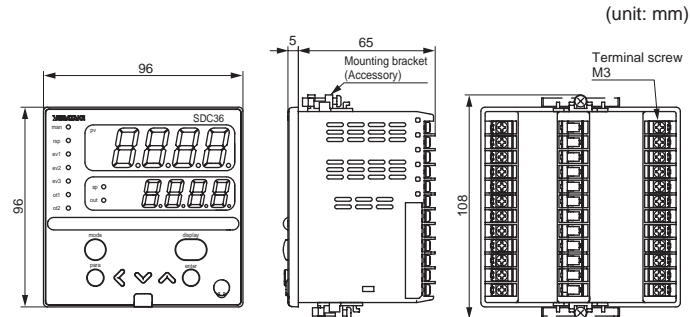

Handling Precautions

To fasten this controller onto the panel, tighten a mounting bracket screws, and turn one more half turn when there is no play between the bracket and panel. Excessively tightening the screws may deform the controller case.

Panel Cutout Dimensions

- C35 (unit: mm)

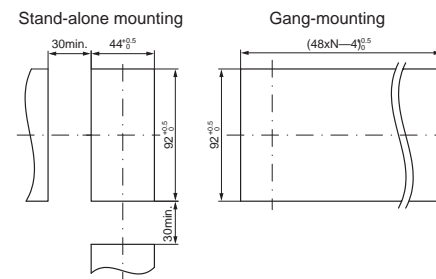

- C36

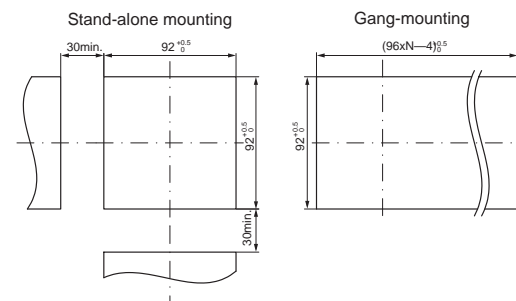

Handling Precautions

- When three or more units are gang-mounted horizontally, the maximum allowable ambient temperature is 40°C.

Wiring

Be sure to provide a switch within operator reach for shutting OFF the main power supply to the controller in the main supply wiring. Also, in case of AC power supply models, the main supply wiring also requires a time-lagged type (T) fuse (rated current: 0.5A, rated voltage: 250 V). (IEC127) The following table shows the meaning of the symbols in the terminal wiring label on the controller side:

Symbols	Meaning
~	AC power supply
—	DC power supply
⚠	Caution, fear of electric shock
⚠	Caution

Handling Precautions

- Before wiring the SDC35/36, verify the controller's model No. and terminal Nos. written on the label on the side of the body. Inspect all wiring once wiring work for the SDC35/36 has been completed.
- Use M3 crimp-type terminal lugs for wiring to terminal.
- Provide a distance of at least 50cm between I/O lead wires or communications lead wires and power lead wires. Also, do not pass these lead wires through the same piping or wiring duct.
- Be careful not to allow any crimp-type terminal lugs to touch adjacent terminals.
- Prepare a heater current conductor to send a heater current through the current transformer. Do not use a heater current that exceeds the specified permissible current as this may damage the controller.
- The current transformer input cannot be used for phase control.

- There is no isolation provided between control output 1 and control output 2. Install an isolator as required.
- Do not connect a terminating resistor to either end of the RS-485 communications line. Doing so may interfere with communication.
- When the power supply voltage of the motor which is connected to the motor drive relay output is 100/200Vac, use an auxiliary relay externally.
- Do not wire in the same duct for the motor drive terminals (13),(14),(15) and the MFB input terminals (7),(8), (9) and also do not use 6-core cable. Failure to follow the instruction might cause controller malfunction due to noise during motor startup operation.
- Regarding a device or equipment which is connected to this controller, use a model to which the basic insulation meeting with the power supply voltage and the maximum operating voltage of the I/O units is provided.
- The controller requires maximum 6 seconds to start up once the power is turned ON. The controller can be used once it has started up. However, it is recommended to allow a warm-up time of at least 30 minutes to attain the specified accuracy.

Connection of C35/36

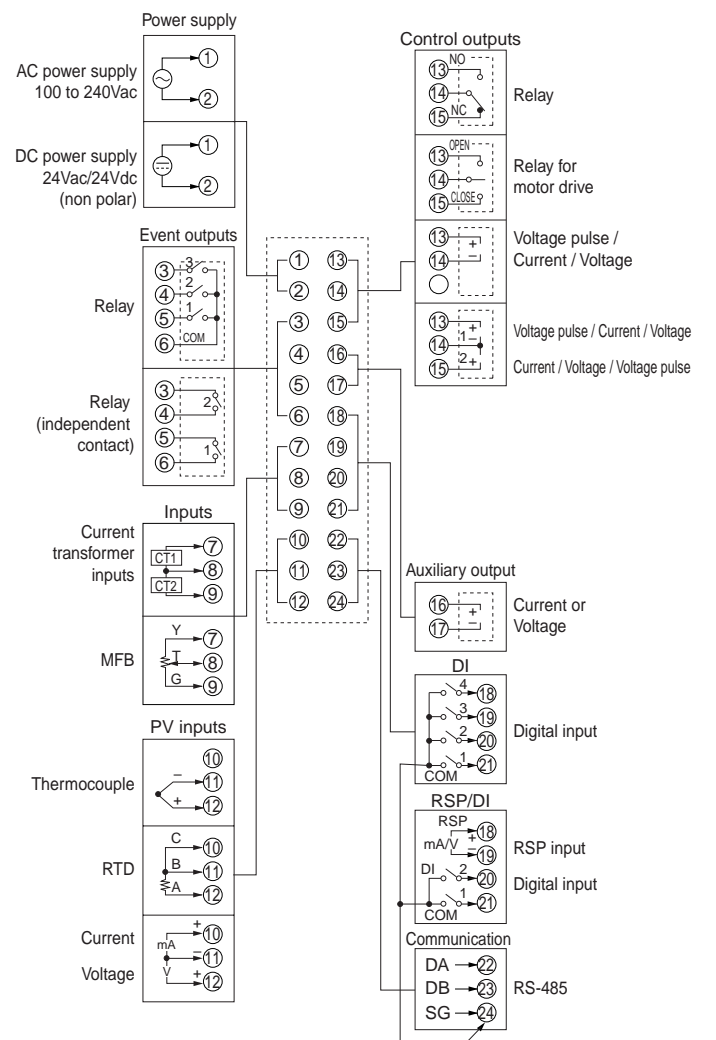

I/O isolation

Items surrounded by solid lines are insulated from other signals.

Power supply	Internal Circuit	Control output 1
PV input Current Transformer input 1 Current Transformer input 2 Motor feedback input Loader communication		Control output 2 Auxiliary output
Digital input 1 Digital input 2 Digital input 3 Digital input 4 RS-485 Communication RSP input		Event output 1 (Note 1) Event output 2 (Note 1) Event output 3

Availability of input or output is based on a model number.

Note 1 In case of independent contact, the part between the event output 1 and the event output 2 is isolated.

Part names and functions

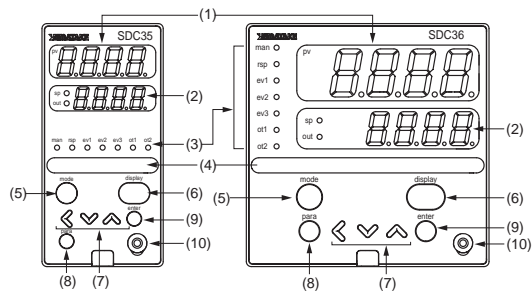

- (1) Upper display: Displays PV values (present temperature etc.) or setting items.
 (2) Lower display: Displays SP values (set temperature, etc.) and other parameter values.
 When the lower display shows the SP value, the "sp" lamp lights up. When the display shows the manipulated variable (MV), the "out" lamp lights up.
 (3) Mode indicator man: Lights when MANUAL (manual mode)
 rsp: Lights when RSP mode (remote setup input) ev1 to ev3: Lights when event relays are ON.
 (4) Multi-status indicator: ot1 to ot2: Lights when the control output is ON.
 In the combination of the lighting condition and the lighting status as a group, the priority 3 groups can be set.
 The operation which has been set beforehand can be done by pushing the key for 1s or more.
 (5) [mode] key: Used to change the display contents in the operation display mode. Display is returned from bank setup display to operation display.
 (6) [display] key: Used for incrementing numeric values and performing arithmetic shift operations.
 (7) <, V, ^ key: Used for incrementing numeric values and performing arithmetic shift operations.
 (8) [para] key: Switches the display.
 (9) [enter] key: Used to set the setup values at the start of change and during the change.
 (10) Loader connector: Connects to a personal computer by using a dedicated cable supplied with the Smart Loader Package.

PV range table

C01 Set value	Sensor type	Range	C01 Set value	Sensor type	Range
1	K	-200 to +1200°C / -300 to +2200°F	41	Pt100	-200.0 to +500.0°C / -300 to +900°F
2	K	0 to 1200°C / 0 to 2200°F	42	JPt100	-200.0 to +500.0°C / -300 to +900°F
3	K	0 to 800°C / 0 to 1500°F	43	Pt100	-200.0 to +200.0°C / -300 to +400°F
4	K	0.0 to 600.0°C / 0 to 1100°F	44	JPt100	-200.0 to +200.0°C / -300 to +400°F
5	K	0.0 to 400.0°C / 0 to 700°F	45	Pt100	-100.0 to +300.0°C / -150 to +500°F
6	K	-200.0 to +400.0°C / -300 to +700°F	46	JPt100	-100.0 to +300.0°C / -150 to +500°F
7	K	-200.0 to +200.0°C / -300 to +400°F	47	Pt100	-100.0 to +200.0°C / -150 to +400°F
8	J	0 to 1200°C / 0 to 2200°F	48	JPt100	-100.0 to +200.0°C / -150 to +400°F
9	J	0.0 to 800.0°C / 0 to 1500°F	49	Pt100	-100.0 to +150.0°C / -150 to +300°F
10	J	0.0 to 600.0°C / 0 to 1100°F	50	JPt100	-100.0 to +150.0°C / -150 to +300°F
11	J	-200.0 to +400.0°C / -300 to +700°F	51	Pt100	-50.0 to +200.0°C / -50 to +400°F
12	E	0.0 to 800.0°C / 0 to 1500°F	52	JPt100	-50.0 to +200.0°C / -50 to +400°F
13	E	0.0 to 600.0°C / 0 to 1100°F	53	Pt100	-50.0 to +100.0°C / -50 to +200°F
14	T	-200.0 to +400.0°C / -300 to +700°F	54	JPt100	-50.0 to +100.0°C / -50 to +200°F
15	R	0 to 1600°C / 0 to 3000°F	55	Pt100	-60.0 to +40.0°C / -60 to +100°F
16	S	0 to 1600°C / 0 to 3000°F	56	JPt100	-60.0 to +40.0°C / -60 to +100°F
17	B	0 to 1800°C / 0 to 3300°F	57	Pt100	-40.0 to +60.0°C / -40 to +140°F
18	N	0 to 1300°C / 0 to 2300°F	58	JPt100	-40.0 to +60.0°C / -40 to +140°F
19	PLII	0 to 1300°C / 0 to 2300°F	59	Pt100	-10.00 to +60.00°C / -10 to +140°F
20	Wre5-26	0 to 1400°C / 0 to 2400°F	60	JPt100	-10.00 to +60.00°C / -10 to +140°F
21	Wre5-26	0 to 2300°C / 0 to 4200°F	61	Pt100	0.0 to 100.0°C / 0 to 200°F
22	Ni-NiMo	0 to 1300°C / 0 to 2300°F	62	JPt100	0.0 to 100.0°C / 0 to 200°F
23	PR40-20	0 to 1900°C / 0 to 3400°F	63	Pt100	0.0 to 200.0°C / 0 to 400°F
24	DIN U	-200.0 to +400.0°C / -300 to +700°F	64	JPt100	0.0 to 200.0°C / 0 to 400°F
25	DIN L	-100.0 to +800.0°C / -150 to +1500°F	65	Pt100	0.0 to 300.0°C / 0 to 500°F
26	Gold iron chromel	0.0K to 360.0K / 0 to 360.0K	66	JPt100	0.0 to 300.0°C / 0 to 500°F
			67	Pt100	0.0 to 500.0°C / 0 to 900°F
			68	JPt100	0.0 to 500.0°C / 0 to 900°F

Handling Precautions

- The accuracy is ±0.1%FS±1 digit, and ±0.2%FS±1 digit for a negative area of the thermocouple.
- The accuracy varies according to the range.
- The accuracy of the No.17 (sensor type B) is ±4.0%FS for a range of 260°C or less, ±0.4%FS for 260 to 800°C and ±0.2%FS for 800 to 1600°C.
- The accuracy of the No.15 (sensor type R) or No.16 (sensor type S) is ±0.2%FS for a range of 100°C or less, and ±0.15%FS for 100 to 1600°C.
- The accuracy of the No.23 (sensor type PR40-20) is ±2.5%FS for 0 to of 300°C, and ±1.5%FS for 300 to 800°C, ±0.5%FS for 800 to of 1900°C.
- The accuracy of the No.26 (sensor type gold iron chromel) is ±1.5K.
- The accuracy of the No. 55 to 62 and 81 are ±0.15%FS for each ranges.
- The accuracy of the No.19 (sensor type PLII) in the range of 0 to 32°F does not meet the indication accuracy.
- For ranges with a decimal point, tenths are displayed on the line underneath point.

C01 Set value	Sensor type	Range
81	0. to 10mV	The scaling and the decimal point position can be changed variably in a range of -1999 to +9999.
82	-10 to +10mV	
83	0 to 100mV	
84	0 to 1V	
86	1 to 5V	
87	0 to 5V	
88	0 to 10V	
89	0 to 20mA	
90	4 to 20mA	

Setting the PV range type

The following shows the flow of key operation:

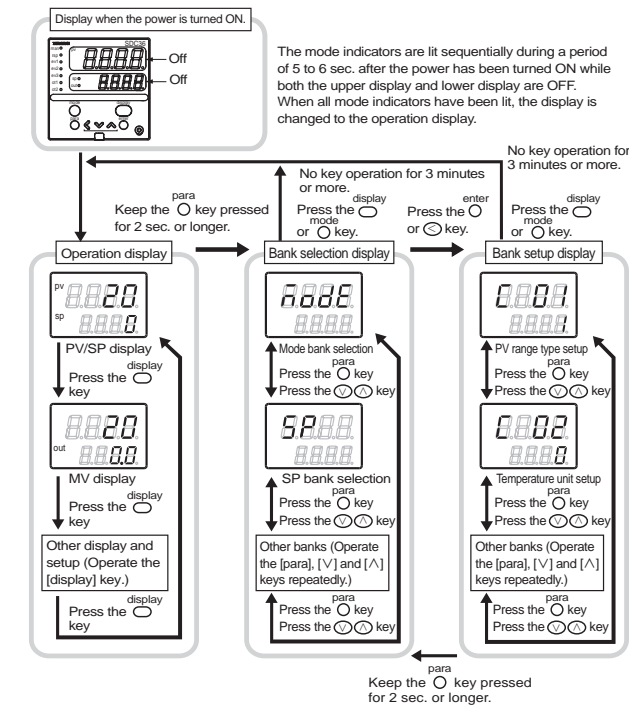

The display and setup status shown above are examples for explanation. Therefore, some displays or settings are not shown actually according to the model and/or setup contents.

There are the standard type and special type in the data setup method. Here, the method is explained in the standard type.

- Setting example of the PV range type**
 Display the $\overline{000}$ on the upper display in the bank setup mode for the setup bank. When the [enter] key is pressed, the numerical value on the lower display will start to flash. Move the digit or increase/decrease the numeric value by pressing the [<] [V] [^] keys. When the [enter] key is pressed at the desired numeric value, the flashing will stop and the data will be set.
- Setting example of the SP1**
 Display the $\overline{5P}$ on the upper display in the bank setup mode of the setup bank. When the [enter] key is pressed, the numerical value on the lower display will start to flash. Move the digit or increase/decrease the numeric value by pressing the [<] [V] [^] keys. When the [enter] key is pressed at the desired numeric value, the flashing will stop and the data will be set.

For the details of the handling and setting method, refer to the following manual:
 Single Loop Controller SDC35/36 User's Manual "Installation & Configurations" CP-SP-1150E

Alarm code table

This table shows the alarm display and measures for the abnormal operation of this controller.

Alarm code	Failure name	Cause	Corrective action
$\overline{RL01}$	PV input failure (over range)	Sensor line break, incorrect wiring, incorrect PV range type setting	Checking wiring or reset PV range type
$\overline{RL02}$	PV input failure (under range)	Sensor line break, incorrect wiring, incorrect PV range type setting	Checking wiring.
$\overline{RL03}$	CJ failure failure	Terminal temperature is faulty (thermocouple).	Checking the ambient temperature.
$\overline{RL05}$	RSP input failure (Over range)	Sensor line break, incorrect wiring, incorrect RSP range setting	Checking wiring or reset RSP range code.
$\overline{RL06}$	RSP input failure (Under range)	Sensor line break, incorrect wiring, incorrect RSP range setting	Checking wiring or reset RSP range code.
$\overline{RL07}$	MFB input failure	Motor line break, incorrect wiring	Checking wiring or confirm the MFB input.
$\overline{RL10}$	Motor adjustment failure	Motor line break, incorrect wiring, motor power supply failure.	Checking wiring, confirm the motor power supply, reset.
$\overline{RL70}$	A/D conversion failure	Defective A/D converter	Replace unit.
$\overline{RL95}$	Parameter failure	• Power turned OFF during fixing data • Data corrupted due to noise, etc.	Re-start the system. Reset data or replace unit. (AL95/97: setting data, AL96/98: tuning data)
$\overline{RL96}$	Adjustment data failure	• Power turned OFF during fixing data • Data corrupted due to noise, etc.	Re-start the system. Replace unit.
$\overline{RL97}$	Parameter failure (RAM area)	Data corrupted due to noise, etc.	
$\overline{RL98}$	Adjustment data failure (RAM area)	Data corrupted due to noise, etc.	
$\overline{RL99}$	ROM failure	ROM (memory) error	Re-start the system. Replace unit.

Maintenance

- Cleaning : When wiping out the SDC35/36, use the soft and dried cloth.
 Parts replacement : Do not replace the parts.
 Fuse replacement : When replacing the fuse for the power supply wires, make sure that the replacement fuse complies with all applicable safety standards.
 Standard IEC127, Cutoff Speed Delayed operation type (T), Rated Voltage 250V, Rated Current 0.5A

Model selection table

Basic model No.	Mounting	Control output	PV input	Power supply	Option 1	Option 2	Additions 1	Additions 2	Specifications
C35									48X96 size model
C36									96X96 size model
									Panel mounting type
									Control output 1
									Control output 2
									Relay contact output NO
									Relay contact output NC
									Relay contact output for motor drive
									Relay contact output for motor drive
									OPEN side
									CLOSE side
									Voltage pulse output (for SSR drive)
									Current output
									Voltage pulse output (for SSR drive)
									Voltage output
									Voltage pulse output (for SSR drive)
									Voltage pulse output (for SSR drive)
									Current output
									Current output
									Current output
									Voltage output
									Voltage output
									Voltage output
									Voltage output
									Universal
									AC model (100 to 240Vac) 50/60Hz
									DC model (24Vac/24Vdc)
									Event relay output 3 points
									Event relay output 3 points, Auxiliary output (current output)
									Event relay output 3 points, Auxiliary output (voltage output)
									Event output: 2 points (independent contact)
									Event output: 2 points (independent contact)
									Auxiliary output (current output)
									Event output: 2 points (independent contact)
									Auxiliary output (voltage output)
									—
									Current transformer input: 2 points
									Digital input: 4 points
									Current transformer input: 2 points
									Digital input: 4 points, RS-485 communication
									Current transformer input: 2 points
									Digital input: 2 points, RSP input
									Current transformer input: 2 points
									Digital input: 2 points, RSP input, RS-485 communication
									—
									No additional treatment
									Inspection certificate provided
									Tropicalization treatment applied
									Anti-sulfide treatment applied
									Tropicalization treatment applied and Inspection certificate provided.
									Anti-sulfide treatment applied and Inspection certificate provided.
									Complying with the traceability certification
									—
									IP65 inapplicable

- Note 1. A current transformer is sold separately.
 Note 2. When the control output is R1, the current transformer input is not applied. MFB input is applied.
 Note 3. Can not be selected for DC model.

Specifications

- PV Inputs**
 Input type: Refer to PV range table
 Sampling cycle: 100ms
 Indication accuracy: ±0.1%FS±1 digit, ±0.2%FS±1 digit for a negative area of the thermocouple (at ambient temperature 23±2°C)
- Cold junction compensation accuracy: ±0.5% (at ambient temperature 23±2°C) ±1.0% (at ambient temperature 15 to 35°C) ±1.5% (at ambient temperature 0 to 15 or 35 to 50°C)
- Cold junction compensation method: The compensation in the controller or the compensation at the outside of the controller (0°C only) can be selected.
- Digital input**
 Input type: Dry contact or open collector
 Allowable ON contact resistance: Max.250Ω
 Allowable OFF contact resistance: Min.100kΩ
 Allowable ON residual voltage: Max.1.0V
 Terminal current (ON): Approx.7.5mA (in case of short circuit).
 Approx.5.0mA (in case of contact resistance 250Ω)
- Minimum hold time: 200ms or more
- Current transformer input**
 Input type: Current transformer 800 turns
 QN206A (5.8mm hole dia.) Sold separately
 QN212A (12mm hole dia.) Sold separately

- Range of measurement current: 0.4 to 50.0A
 Indication accuracy: ±5%FS±1digit
 Indication range: 0.0 to 70.0A
- Motor feedback potentiometer input (R1 model)**
 Allowable resistance: 100 to 2500Ω
 Detection of line break: Displays AL07.
- RSP input**
 Input type: linear 0 to 20mA/4 to 20mA or linear 0 to 5V/1 to 5V/0 to 10V
 100ms
 Indication accuracy: ±0.1%FS±1 digit (at ambient temperature 23±2°C)
 Operation at input break: Downscale + AL06
- Control outputs**
 Relay output
 Contact rating: NO side 250Vac/30Vdc, 3A (resistive load)
 NC side 250Vac/30Vdc, 1A (resistive load)
 Life: NO side Min. 50,000 operations
 NC side Min. 100,000 operations
- Min. switching specifications: 5V, 100mA
 Min. open time / close times: 250ms
- Motor drive relay output (R1 model)**
 Output rating: 250Vac 8A (resistive load)
 Life: Min. 120,000 operations
 Min. switching specifications: 24V dc, 40mA
- Voltage pulse output (for SSR drive)**
 Open circuit voltage: 19Vdc±15%
 Internal resistance: 82Ω±0.5%
 Allowable current: Max. 24mA
 Min OFF time / ON time: 1ms when the time proportional cycle time is less than 10s.
 250ms when the time proportional cycle time is more than 10s.
- Current output**
 Output type: 0 to 20mAdc or 4 to 20mAdc
 Allowable load resistance: Max.600Ω
 Output accuracy: ±0.1%FS (at ambient temperature 23±2°C)
 ±1%FS at 0 to 1mA
- Voltage output**
 Output type: 0 to 5Vdc/1 to 5V or 0 to 10V
 Allowable load resistance: Min. 1000Ω
 Output accuracy: ±0.1%FS (at ambient temperature 23±2°C)
 ±1%FS at 0 to 0.05V
- Auxiliary output**
 Current output
 Output type: 0 to 20mAdc or 4 to 20mAdc
 Allowable load resistance: 600Ωmax.
 Output accuracy: ±0.1%FS (at ambient temperature 23±2°C)
 ±1%FS at 0 to 1mA
- Voltage output**
 Output type: 0 to 5V/1 to 5Vdc or 0 to 10Vdc
 Allowable load resistance: Min. 1000Ω
 Output accuracy: ±0.1%FS (at ambient temperature 23±2°C)
 ±1%FS at 0 to 0.05V
- Event relay outputs (ev1 to 3)**
 Output rating: 250Vac/30Vdc 2A (resistive load)
 Life: Min. 100,000 operations
 Min. switching specifications: 5V, 10mA (reference value)
- RS-485 communication**
 Transmission line: 3-wire system
 Transmission speed: 4800, 9600, 19200, 38400bps
 Communication protocol: CPL and MODBUS conforming
 Terminating resistor: Do not connect a terminating resistor.
- Environmental conditions**
 Operating conditions
 Ambient temperature: 0 to 50°C (Gang-mounting: 0 to 40°C)
 Ambient humidity: 10 to 90%RH (non condensing)
 Rated power supply voltage: AC model 100 to 240Vac, 50/60Hz
 DC model 24Vac 50/60Hz, 24Vdc
 Power supply voltage range: AC model 85 to 264Vac, 50/60±2Hz
 DC model 21.6 to 26.4Vdc 50/60±2Hz, 21.6 to 26.4Vdc
- Transport conditions**
 Ambient temperature: -20 to +70°C
 Ambient humidity: 10 to 95%RH (non condensing)
- Other specifications**
 Power consumption: Max. 12VA for AC model
 Max. 12VA for DC model at 24Vdc
 Max. 8W for DC model at 24Vdc
 2000m or less
 C35 Approx.250g (with mounting bracket)
 C36 Approx.300g (with mounting bracket)
- Altitude: 2000m or less
 Mass: C35 Approx.250g (with mounting bracket)
 C36 Approx.300g (with mounting bracket)
- Terminal screw tightening torque: 0.4N·m Max.
 Applicable standards: EN61010-1, EN61326-1
 Overvoltage category: Category II (IEC60364-4-443, IEC60664-1)
 Allowable pollution degree: Pollution degree 2

Accessories and optional parts

Name	Model No.
Mounting bracket	81409654-001(Accessory)
Current transformer	QN206A(5.8mm hole dia.) QN212A(12mm hole dia.)
Hard cover	81446915-001(for C35) 81446916-001(for C36)
Terminal cover	81446912-001(for C35) 81446913-001(for C36)

SDC35/36 List of Parameters

[List of Operation Displays]

■ Operation Displays

Display	Item	Contents	Initial value	User level
Upper display: PV Lower display: SP	SP (Target value)	SP low limit (C07) to SP high limit (C08)	0	0
LSP (Display example) Lower display: LSP	LSP No. (1st digit: Value at the right end digit)	1 to LSP system group (C30 Max. 8)	1	0
SE (Display example) Lower display: Step remaining time	Step operation remaining time	Setting is disabled. Upper display: The distinction by step No., ramp-up, ramp-down or soak is displayed at the side location of [St]. Lower display: Displayed by the unit (either one of 0.1s, min.s, or h.min) based on the step operation time unit (C33).	—	0
Upper display: PV Lower display: MV	MV (Manipulated Variable)	-10.0 to +110.0% Setting is disabled in AUTO mode. (Numeric value does not flash.) Setting is enabled in MANUAL mode. (Numeric value flashes.)	—	0
HEM	Heat MV (Manipulated Variable)	Setting is disabled -10.0 to +110.0%	—	0
COOL	Cool MV (Manipulated Variable)	Setting is disabled. -10.0 to +110.0% For estimation, displayed by flashing in 0.1 to 100.0%.	—	0
Fb	MFB (Motor opening feedback value)	Setting is disabled. -10.0 to +110.0%	—	0
Upper display: PV RE (Display example)	AT progress display (1st digit = Numeric value at right end digit)	Setting is disabled. Except for 0: During execution of AT (Value is decreased.) 0: Completion of AT	—	0
CE	CT (Current transformer) current value 1	Setting is disabled.	—	0
CE2	CT (Current transformer) current value 2	Setting is disabled.	—	0
E1	Internal event 1 main setting	Setting range is different depending on the internal event operation type. -1999 to +9999U: Except below. 0 to 9999U: Setting value is an absolute value. -199.9 to +999.9%: For MV.	0	0
E1.5b	Internal event 1 sub-setting	Setting range is different depending on the internal event operation type. -1999 to +9999U: Except below. 0 to 9999U: Setting value is an absolute value. -199.9 to +999.9%: For MV.	0	0
E1.1 (Display example)	Timer remaining time 1	Setting is disabled. Upper display: The distinction by ON delay or OFF delay is displayed at the side location of [t1]. Lower display: Displayed by the unit (either one of 0.1s, s, or min) based on the internal event 1 delay time unit (E1, the 3rd digit of C3).	—	0
E2	Internal event 2 main setting	Setting range is different depending on the internal event operation type. -1999 to +9999U: Except below. 0 to 9999U: Setting value is an absolute value. -199.9 to +999.9%: For MV.	0	0
E2.5b	Internal event 2 sub-setting	Setting range is different depending on the internal event operation type. -1999 to +9999U: Except below. 0 to 9999U: Setting value is an absolute value. -199.9 to +999.9%: For MV.	0	0
E2.1 (Display example)	Timer remaining time 2	Setting is disabled. Upper display: The distinction by ON delay or OFF delay is displayed at the side location of [t2]. Lower display: Displayed by the unit (either one of 0.1s, s, or min) based on the internal event 2 delay time unit (E2, the 3rd digit of C3).	—	0
E3	Internal event 3 main setting	Setting range is different depending on the internal event operation type. -1999 to +9999U: Except below. 0 to 9999U: Setting value is an absolute value. -199.9 to +999.9%: For MV.	0	0
E3.5b	Internal event 3 sub-setting	Setting range is different depending on the internal event operation type. -1999 to +9999U: Except below. 0 to 9999U: Setting value is an absolute value. -199.9 to +999.9%: For MV.	0	0
E3.1 (Display example)	Timer remaining time 3	Setting is disabled. Upper display: The distinction by ON delay or OFF delay is displayed at the side location of [t3]. Lower display: Displayed by the unit (either one of 0.1s, s, or min) based on the internal event 3 delay time unit (E3, the 3rd digit of C3).	—	0

[List of Parameter Setting Displays]

■ Mode bank

Bank selection: MOD

Display	Item	Contents	Initial value	User level
R--R	AUTO/MANUAL mode selection	RUTO : AUTO mode RMAN : MANUAL mode	AUTO	0
r--r	RUN/READY mode selection	rUN : RUN mode rDY : READY mode	RUN	0
L--L	LSP/RSP mode selection	LSP : LSP mode RSP : RSP mode	LSP	0
RE	AT Stop/Start selection	RE : AT Stop RE : AT Start	AT Stop	0
doL	Release all DO latches	do : Latch continue of : Latch release	Latch continue	0
di	Communication DI 1	di : ON of : OFF	OFF	0

■ SP bank

Bank selection: SP

Display	Item	Contents	Initial value	User level
rSP	RSP	Setting is disabled.	—	0
PID.r	PID group No.	1 to 8	1	1
SP-1 to SP-8	SP of LSP1 group to SP of LSP8 group	SP low limit (C07) to SP high limit (C08)	0	0
PID.1 to PID.8	PID group No. (for LSP1 to 8)	1 to 8	1	1
rSP.1 to rSP.8	Ramp (for LSP1 to 8)	0 to 9999 (The decimal point position is determined by the PV decimal point position and the SP ramp unit.)	0	2
EA.1 to EA.8	Time (for LSP1 to 8)	0.0 to 999.9 (when step operation time unit is 0.1s.) 0 to 9999 (when step operation time unit is 1s or 1min.)	0	2

User level details 0: Display in basic/standard/high function,
1: Display in standard/high function,
2: Display in high function.

Initial value may vary depending on model No.

■ Event bank

Bank selection: EV

Display	Item	Contents	Initial value	User level
E1 to E8	Internal event 1 to 8, main setting	-1999 to +9999 The decimal point position varies by meeting the internal event operation type.	0	0
E1.5b to E8.5b	Internal event 1 to 8, sub-setting	0 to 9999 for some operation type.	0	0
E1.HY to E8.HY	Internal event 1 to 8, hysteresis	0 to 9999 The decimal point position varies by meeting the internal event operation type.	5	0
E1.ON to E8.ON	Internal event 1 to 8, ON delay	0.0 to 999.9 (For the delay time unit 0.1s)	0	2
E1.OF to E8.OF	Internal event 1 to 8, OFF delay	0 to 9999 (Except for the delay time unit 0.1s)	0	2

■ PID bank

Bank selection: PID

Display	Item	Contents	Initial value	User level
P-1 to P-8	Proportional band (PID1 to 8 group)	0.1 to 999.9%	5.0	0
I-1 to I-8	Integration time (PID1 to 8 group)	0 to 9999s or 0.0 to 999.9s (0: No integral control action)	120	0
D-1 to D-8	Derivative time (PID1 to 8 group)	0 to 9999s or 0.0 to 999.9s (0: No derivative control action)	30	0
RE-1 to RE-8	Manual reset (PID1 to 8 group)	-10.0 to +110.0%	50.0	0
OL-1 to OL-8	MV low limit (PID1 to 8 group)	-10.0 to +110.0%	0.0	1
OH-1 to OH-8	MV high limit (PID1 to 8 group)	-10.0 to +110.0%	100.0	1
P-1C to P-8C	Cool-side proportional band (PID1 to 8 group)	0.1 to 999.9%	5.0	0
I-1C to I-8C	Cool-side integration time (PID1 to 8 group)	0 to 9999s or 0.0 to 999.9s (0: No integral control action)	120	0
D-1C to D-8C	Cool-side derivative time (PID1 to 8 group)	0 to 9999s or 0.0 to 999.9s (0: No derivative control action)	30	0
OL-1C to OL-8C	Cool-side MV low limit (PID1 to 8 group)	-10.0 to +110.0%	0.0	1
OH-1C to OH-8C	Cool-side MV high limit (PID1 to 8 group)	-10.0 to +110.0%	100.0	1

■ Parameter bank

Bank selection: PAR

Display	Item	Contents	Initial value	User level
CE-L	Control method	0: ON/OFF control 1: PID fixed	0 or 1	0
RE.OL	MV low limit at AT	-10.0 to +110.0%	0.0	0
RE.OH	MV high limit at AT	-10.0 to +110.0%	100.0	0
DIFF	ON/OFF control differential	0 to 9999U	5	0
OFFS	ON/OFF control operating point offset	-1999 to 9999U	0	2
FL	PV filter	0.0 to 120.0s	0.0	0
FR	PV ratio	0.001 to 9.999	1.000	1
b	PV bias	-1999 to +9999U	0	0
FL2	RSP filter	0.0 to 120.0s	0.0	0
FR2	RSP ratio	0.001 to 9.999	1.000	1
b2	RSP bias	-1999 to +9999U	0	0
CYU	Time proportional cycle unit 1	0: 1s unit 1: 0.5s fixed (Cycle time is disabled.) 2: 0.2s fixed (Cycle time is disabled.) 3: 0.1s fixed (Cycle time is disabled.)	0	2
CY	Time proportional cycle1	5 to 120s (* 1) 1 to 120s (* 2)	10 or 2	0
CYU2	Time proportional cycle unit 2	0: 1s unit 1: 0.5s fixed (Cycle time is disabled.) 2: 0.2s fixed (Cycle time is disabled.) 3: 0.1s fixed (Cycle time is disabled.)	0	2
CY2	Time proportional cycle 2	5 to 120s (* 1) 1 to 120s (* 2)	10 or 2	0
EP.EY	Time proportional operation type	0: Controllability aiming type 1: Actuator life aiming type (Only one ON/OFF operation within time proportional cycle time)	0 or 1	2
oVL	MV variation limit	0.0 to 999.9%/s (0.0: No limit)	0.0	2
SPU	SP ramp-up	0.0 to 999.9U (0.0: No ramp)	0.0	2
SPD	SP ramp-down	0.0 to 999.9U (0.0: No ramp)	0.0	2

* 1 When the output includes the relay output.
* 2 When the output does not include the relay output.

■ Extension tuning bank

Bank selection: ET

Display	Item	Contents	Initial value	User level
RE.EY	AT type	0: Normal (Standard control characteristics) 1: Immediate response (Control characteristics immediately responding to the external disturbance.) 2: Stable (Control characteristics with less up/down function of PV)	1	0
JF.BD	Just-FITTER setting band	0.00 to 10.00	0.30	2
SP.LS	SP lag constant	0.0 to 999.9	0.0	2
RE-P	AT proportional band tuning factor	0.00 to 99.99	1.00	2
RE-I	AT integration time tuning factor	0.00 to 99.99	1.00	2
RE-D	AT derivative time tuning factor	0.00 to 99.99	1.00	2
CE.r.R	Control algorithm	0: PID (conventional PID) 1: Rational.OOP (high performance type)	0	1
JF.OV	Just-FITTER overshoot suppression factor	0 to 100	0	1

■ Zone bank

Bank selection: ZONE

Display	Item	Contents	Initial value	User level
Zn-1	Zone1	-1999 to +9999U	9999U	2
Zn-2	Zone2	Same as CT1.	9999U	2
Zn-3	Zone3		9999U	2
Zn-4	Zone4		9999U	2
Zn-5	Zone5		9999U	2
Zn-6	Zone6		9999U	2
Zn-7	Zone7		9999U	2
Zn.dF	Zone hysteresis	0 to 9999	5U	2

[List of Setup Setting Displays]

■ Setup bank

Bank selection: SETUP

Display	Item	Contents	Initial value	User level
CE.1	PV input range type	Thermocouple: 1 to 26 RTD: 41 to 68 DC current/voltage: 81 to 84, 86 to 90	88	0
CE.2	Temperature unit	0: Centigrade (°C) 1: Fahrenheit (°F)	0	0
CE.3	Cold junction compensation	0: Cold junction compensation is performed. (Internal) 1: Cold junction compensation is not performed. (External)	0	2
CE.4	Decimal point position	0: No decimal point 1: One digit after decimal point 2: Two digits after decimal point 3: Three digits after decimal point (Select '0' or '1' for the thermocouple/RTD range with decimal point)	0	0
CE.5	PV range low limit	When the PV input range type is thermocouple or RTD, the setting is disabled although range low limit is displayed. -1999 to +9999U when the PV input range type is DC voltage/current.	0	0
CE.6	PV range high limit	When the PV input range type is thermocouple or RTD, the setting is disabled although range high limit is displayed. -1999 to +9999U when the PV input range type is DC voltage/current.	1000	0
CE.7	SP low limit	PV input range low limit to PV input range high limit	0	1
CE.8	SP high limit		1000	1
CE.9	Squarer root extraction dropout	0.0 to 100.0% (0.0: No square root extraction)	0.0	2
CE.10	RSP range type	0: 4 to 20mA 1: 0 to 20mA 2: 0 to 5V 3: 1 to 5V 4: 0 to 10V	0	0
CE.11	RSP range low limit	-1999 to +9999U	0	0
CE.12	RSP range high limit		1000	0
CE.13	Control action (direct/reverse)	0: Heat control (reverse action) 1: Cool control (direct action)	0	0
CE.14	Selection of MV at PV alarm occurrence	0: Control operation is continued. 1: MV at PV alarm occurrence is outputted.	0	2
CE.15	MV at PV alarm occurrence	-10.0 to +110.0%	0.0	2
CE.16	MV at READY (at heat-side for heat/cool control)	-10.0 to +110.0%	0.0	1
CE.17	MV at READY (at cool-side)	-10.0 to +110.0%	0.0	1
CE.18	Operation at MANUAL change	0: Bump-less 1: Preset	0	1
CE.19	Preset MANUAL value	-10.0 to +110.0% (Used even at MANUAL mode when power is ON.)	0.0 or 50.0	1
CE.20	PID operation initialization function selection	0: Automatic 1: Not initialized 2: Initialized (when SP value different from current value is inputted.)	0	2
CE.21	PID operation initial MV	-10.0 to +110.0%	0.0 or 50.0	2
CE.22	Control parameter decimal point	0: No decimal point 2: One digit after decimal point (Decimal point of integration time or derivative time)	0	2
CE.23	Zone PID action selection	0: Disabled 1: Selection by SP 2: Selection by PV	0	2
CE.24	Heat/cool control selection	0: Disabled. 1: Enabled.	0	0
CE.25	Heat/cool selection	0: Normal 1: Energy saving	0	1
CE.26	Dead zone	-100.0 to +100.0%	0.0	0
CE.27	Heat/cool control selection point	-10.0 to +110.0%	50.0	2
CE.28	LSP setting system	1 to 8	1	0
CE.29	SP ramp type	0: Standard: 1: Multi-ramp 2: Step operation. Step is stopped when power is re-supplied. (READY) 3: Step operation. Step is recovered when power is re-supplied.	0	2
CE.30	SP ramp unit	0: 0.1U/s 1: 0.1U/min 2: 0.1U/h	1	2
CE.31	Step operation time unit	0: 0.1s 1: 1s (Displayed in min.s in console.) 2: 1min (Displayed in h.min in console.)	0	2
CE.32	Step operation PV start	0: Disabled. 1: Enabled.	0	2
CE.33	Step operation loop	0: Stop (Not looped.) 1: Looped. 2: Final step continued. (Not looped.)	0	2
CE.34	CT1 operation type	0: Control output 1 1: Control output 2 2: Event output 1 3: Event output 2 4: Event output 3	0	0
CE.35	CT1 output	0: Disabled. 1: Enabled.	0	0
CE.36	CT1 measurement wait time	30 to 300ms	30	0
CE.37	CT2 operation type	Same as CT1.	0	0

Display	Item	Contents	Initial value	User level
CE.38	CT2 output	Same as CT1.		
CE.39	CT2 measurement wait time	Same as CT1.	30	0
CE.40	Control output 1 range	Current output: 1: 4 to 20mA 2: 0 to 20mA Continuous voltage output: 1: 1 to 5V 2: 0 to 5V 3: 0 to 10V	1	0
CE.41	Control output 1 type	0: MV 1: Heat MV (for heat/cool control) 2: Cool MV (for heat/cool control) 3: PV 4: PV before ratio bias filter 5: SP 6: Deviation 7: CT1 current value 8: CT2 current value 9: MFB (Including estimation MFB)	0	0
CE.42	Control output 1 scaling low limit	-1999 to +9999 (The decimal point position and unit may vary depending on the control output 1 type.)	0.0	0
CE.43	Control output 1 scaling high limit		100.0	0
CE.44	Control output 2 range type	Same as control output 1.	1	0
CE.45	Control output 2 scaling low limit	-1999 to +9999 (The decimal point position and unit may vary depending on the control output 2 type.)	0	0
CE.46	Control output 2 scaling high limit		1000	0
CE.47	Auxiliary output range	Same as control output 1.	1	0
CE.48	Auxiliary output type	-1999 to +9999 (The decimal point position and unit may vary depending on the auxiliary output type.)	0	0
CE.49	Auxiliary output scaling low limit		1000	0
CE.50	Auxiliary output scaling high limit		1000	0
CE.51	Position proportional control method selection	0: MFB control + estimated position control 1: MFB control 2: Estimated position control (MFB disabled) 3: Estimated position control (MFB disabled) + position adjustment at power supply ON	0	0
CE.52	Position proportional control dead zone	0.5 to 25.0%	10.0	0
CE.53	Position proportional control long life	0: Controllability aiming type 1: Potentiometer life aiming type	1	0
CE.54	Position proportional control tuning start	0: Stop 1: Start	0	0
CE.55	Position proportional full-close tuning value	0 to 9999	1000	0
CE.56	Position proportional full-open tuning value	0 to 9999	3000	0
CE.57	Position proportional full-open time	5.0 to 240.0s	30.0	0
CE.58	Communication type	0: CPL 1: MODBUS ASCII format 2: MODBUS RTU format	0	0
CE.59	Station address	0 to 127 (Communication is disabled when "0" is set.)	0	0
CE.60	Transmission speed	0: 4800bps 1: 9600bps 2: 19200bps 3: 38400bps	2	0
CE.61	Data format (data length)	0: 7bit 1: 8bit	1	0
CE.62	Data format (parity)	0: Even parity 1: Odd parity 2: No parity	0	0
CE.63	Data format (stop bits)	0: 1bit 1: 2bits	0	0
CE.64	Communication minimum response time	1 to 250ms		

■ Event assignment bank

Bank selection: EUCF

Display	Item	Contents	Initial value	User level
74	PV/SP value display setup	Whether the basic display is enabled or disabled is determined by the sum of the following weighting: Bit 0: PV display 0: Disabled, +1: Enabled Bit 1: SP display 0: Disabled, +2: Enabled Bit 2: LSP group No. display 0: Disabled, +4: Enabled Other invalid setup: 0, +8	15	1
75	MV display setup	Whether the basic display is enabled or disabled is determined by the sum of the following weighting: Bit 0: MV display 0: Disabled, +1: Enabled Bit 1: Heat MV/cool MV display 0: Disabled, +2: Enabled Bit 2: MFB display 0: Disabled, +4: Enabled Bit 3: AT progress display 0: Disabled, +8: Enabled	15	1
76	Event setting value display setup	0: In the operation display mode, the internal event setting value is not displayed. 1: In the operation display mode, the internal event 1 setting value is displayed. 2: In the operation display mode, the internal event 1 to 2 setting value is displayed. 3: In the operation display mode, the internal event 1 to 3 setting value is displayed.	0	1
77	Event remaining time display setup	0: In the operation display mode, the ON/OFF delay remaining time of the internal event is not displayed. 1: In the operation display mode, the ON/OFF delay remaining time of the internal event 1 is displayed. 2: In the operation display mode, the ON/OFF delay remaining time of the internal event 1 to 2 is displayed. 3: In the operation display mode, the ON/OFF delay remaining time of the internal event 1 to 3 is displayed.	0	1
78	CT input current value display setup	0: In the operation display mode, the CT current value is not displayed. 1: In the operation display mode, the CT1 current value is displayed. 2: In the operation display mode, the CT1 to 2 current value is displayed.	0	1
79	User level	0: Basic configuration 1: Standard configuration 2: High function configuration	0	0
80	LED monitor	0: Disabled 1: Flashing at RS-485 communication signal transmission 2: Flashing at RS-485 communication signal receiving 3: OR (logical sum) of all DI status 4: Flashing at READY	0	2
81	MS indicating lamp ON condition (1st priority)	0: Normally open (Normally OFF=0) 1: Normally close (Normally ON=1) 2 to 9: Internal event 1 to 8 10 to 13: Undefined 14: MV1 (ON/OFF, time proportional 1, heat-side, OPEN-side output) 15: MV2 (time proportional 2, cool-side, CLOSE-side output) 16 to 17: Undefined 18 to 21: DI1 to DI4 22 to 25: Undefined 26 to 30: Internal contact 1 to 5 31 to 33: Undefined 34 to 37: Communication DI1 to DI4 38: MANUAL 39: READY 40: RSP 41: AT 42: During ramp 43: Undefined 44: Alarm 45: PV alarm 46: Undefined 47: Mode key function selection status 48: Event output 1 status 49: Control output 1 status	39	2
82	MS indicating lamp ON status (1st priority)	0: Lit 1: Slow flashing 2: 2 times flashing 3: Fast flashing 4: Left → Right 5: Right → Left 6: Right to left going and returning 7: Deviation OK 8: Deviation graph 9: MV graph 10: Heat-side MV graph 11: Cool-side MV graph 12: MFB graph 13: DI monitor 14: Internal contact monitor 15: Internal event monitor	1	2
83	MS indicating lamp ON condition (2nd priority)	Same as MS indicating lamp ON condition (1st priority)	44	2
84	MS indicating lamp ON status (2nd priority)	Same as MS indicating lamp ON status (1st priority)	6	2
85	MS indicating lamp ON condition (3rd priority)	Same as MS indicating lamp ON condition (1st priority)	1	2
86	MS indicating lamp ON status (3rd priority)	Same as MS indicating lamp ON status (1st priority)	9	2
87	MS indicating lamp deviation range	0 to 9999U	5	2
88	Special function	0 to 15 (0 at power supply ON.)	0	2
89	Zener barrier adjustment	Rewriting by adjustment is enabled. Numerical value inputting manually is disabled	0.00	2

Display	Item	Contents	Initial value	User level
EUCF to EUCF	Operation type of internal event 1 to 8 Configuration 1 Operation type	0: No event 1: PV high limit 2: PV low limit 3: PV high/low limit 4: Deviation high limit 5: Deviation low limit 6: Deviation high/low limit 7: Deviation high limit (Final SP reference) 8: Deviation low limit (Final SP reference) 9: Deviation high/low limit (Final SP reference) 10: SP high limit 11: SP low limit 12: SP high/low limit 13: MV high limit 14: MV low limit 15: MV high/low limit 16: CT1 heater burnout/over-current 17: CT1 heater short-circuit 18: CT2 heater burnout/over-current 19: CT2 heater short-circuit 20: Loop diagnosis 1 21: Loop diagnosis 2 22: Loop diagnosis 3 23: Alarm (status) 24: READY (status) 25: MANUAL (status) 26: RSP (status) 27: During AT execution (status) 28: During SP ramp (status) 29: Control direct action (status) 30: Invalid 31: During motor opening estimation (status) 32: Timer (status)	0	0
EUCF to EUCF	Internal event 1 to 8 Configuration 2	Digits are called as 1st digit, 2nd digit, 3rd digit and 4th digit from the right end digit. 1st digit: 0: Direct 1: Reverse 2nd digit: 0: None 1: Standby 2: Standby + Standby at SP change 3rd digit: 0: Continue 1: Forced OFF 4th digit: 0: Undefined	0000	0
EUCF to EUCF	Internal event 1 to 8 Configuration 3	Digits are called as 1st digit, 2nd digit, 3rd digit and 4th digit from the right end digit. 1st digit: 0: No event 1: Alarm direct + OR operation 2: Alarm direct + AND operation 3: Alarm reverse + OR operation 4: Alarm reverse + AND operation 2nd digit: 0: As normal execution 1: Event OFF at the event setting value (main)=0 3rd digit: 0: 0.1s 1: 1s 2: 1min 4th digit: 0: Undefined	0000	2

■ DI assignment bank

Bank selection: d'

Display	Item	Contents	Initial value	User level
d' to d'5	Internal contact 1 to 5 Operation type	0: No function 1: LSP group selection (0/+1) 2: LSP group selection (0/+2) 3: LSP group selection (0/+4) 4: PID group selection (0/+1) 5: PID group selection (0/+2) 6: PID group selection (0/+4) 7: RUN/READY selection 8: AUTO/MANUAL selection 9: LSP/RSP selection 10: AT Stop/Start 11: Invalid 12: Control action direct/reverse selection (As per setting/opposite operation of setting) 13: SP ramp Enabled/Disabled 14: PV Hold (No-hold/Hold) 15: PV maximum value hold (No-hold/Hold) 16: PV minimum value hold (No-hold/Hold) 17: Timer Stop/Start 18: Release of all DO latches (Continue/Release) 19: Advance (No advance/Advance) 20: Step hold (No hold/Hold)	0	0
d'2 to d'5	Internal contact 1 to 5 Input bit operation	0: Disabled. (Input of default) 1: Function 1 ((A and B) or (C and D)) 2: Function 2 ((A or B) and (C or D)) 3: Function 3 (A or B or C or D) 4: Function 4 (A and B and C and D)	0	2

Display	Item	Contents	Initial value	User level
d'3 to d'5	Internal contact 1 to 5 Input assignment A	0: Normally open (OFF, 0) 1: Normally close (ON, 1) 2: DI1 3: DI2 4: DI3 5: DI4 6 to 9: Undefined 10: Internal event 1 11: Internal event 2 12: Internal event 3 13: Internal event 4 14: Internal event 5 15: Internal event 6 16: Internal event 7 17: Internal event 8 18: Communication DI1 19: Communication DI2 20: Communication DI3 21: Communication DI4 22: MANUAL mode 23: READY mode 24: RSP mode 25: During AT execution 26: During SP ramp	2 to 5 or 0	2
d'4 to d'5	Internal contact 1 to 5 Input assignment B	11: Internal event 2 12: Internal event 3 13: Internal event 4 14: Internal event 5 15: Internal event 6 16: Internal event 7 17: Internal event 8	0	2
d'5 to d'5	Internal contact 1 to 5 Input assignment C	18: Communication DI1 19: Communication DI2 20: Communication DI3 21: Communication DI4 22: MANUAL mode 23: READY mode 24: RSP mode 25: During AT execution 26: During SP ramp	0	2
d'6 to d'5	Internal contact 1 to 5 Input assignment D	27: Undefined 28: Alarm is enabled. 29: PV alarm is enabled. 30: Undefined 31: Mode key function selection status 32: Event output 1 status 33: Control output 1 status	0	2
d'7 to d'5	Internal contact 1 to 5 Polarity A to D	Digits are called as 1st digit, 2nd digit, 3rd digit and 4th digit from the right end digit. 1st digit: Polarity A (Polarity of input assignment A) 2nd digit: Polarity B (Polarity of input assignment B) 3rd digit: Polarity C (Polarity of input assignment C) 4th digit: Polarity D (Polarity of input assignment D)	0000	2
d'8 to d'5	Internal contact 1 to 5 Polarity	0: Direct 1: Reverse	0	2
d'9 to d'5	Internal contact 1 to 5 Internal event No. assignment	0: Disabled 1 to 8: Internal event numbers for timer stop/start	0	2

■ DO assignment bank

Bank selection: d'o

Display	Item	Contents	Initial value	User level
d'o to d'o5	Control output 1 to 2, event output 1 to 3 Operation type	0: Input of default 1: MV1 (ON/OFF control output, time proportional output, heat-side proportional output of heat/cool control) 2: MV2 (cool-side proportional output of heat/cool control) 3: Function 1 ((A and B) or (C and D)) 4: Function 2 ((A or B) and (C or D)) 5: Function 3 (A or B or C or D) 6: Function 4 (A and B and C and D)	0	2
d'o2 to d'o3	Control output 1 to 2, event output 1 to 3 Output assignment A	0: Normally open (OFF, 0) 1: Normally close (ON, 1) 2: Internal event 1 3: Internal event 2 4: Internal event 3 5: Internal event 4 6: Internal event 5 7: Internal event 6 8: Internal event 7 9: Internal event 8	14 to 15 or 2 to 4	2
d'o3 to d'o3	Control output 1 to 2, event output 1 to 3 Output assignment B	10 to 13: Undefined 14: MV1 15: MV2 16 to 17: Undefined 18: DI1 19: DI2 20: DI3 21: DI4 22 to 25: Undefined 26: Internal contact 1 27: Internal contact 2 28: Internal contact 3 29: Internal contact 4 30: Internal contact 5 31 to 33: Undefined 34: Communication DI1 35: Communication DI2 36: Communication DI3 37: Communication DI4 38: MANUAL mode	0	2
d'o4 to d'o5	Control output 1 to 2, event output 1 to 3 Output assignment C	39: READY mode 40: RSP mode 41: During AT execution 42: During SP ramp 43: Undefined 44: Alarm is enabled. 45: PV alarm is enabled. 46: Undefined 47: Mode key function selection status 48: Event output 1 status 49: Control output 1 status	0	2
d'o5 to d'o5	Control output 1 to 2, event output 1 to 3 Output assignment D	40: RSP mode 41: During AT execution 42: During SP ramp 43: Undefined 44: Alarm is enabled. 45: PV alarm is enabled. 46: Undefined 47: Mode key function selection status 48: Event output 1 status 49: Control output 1 status	0	2

Display	Item	Contents	Initial value	User level
d'o6 to d'o3	Control output 1 to 2, event output 1 to 3 Polarity A to D	Digits are called as 1st digit, 2nd digit, 3rd digit and 4th digit from the right end digit. 1st digit: Polarity A 2nd digit: Polarity B 3rd digit: Polarity C 4th digit: Polarity D	0000	2
d'o7 to d'o3	Control output 1 to 2, event output 1 to 3 Polarity	0: Direct 1: Reverse	0	2
d'o8 to d'o3	Control output 1 to 2, event output 1 to 3 Latch	0: Disabled 1: Enabled (Latch at ON) 2: Enabled (Latch at OFF, except at the time of initialization after power ON)	0	2

■ User function bank

Bank selection: U'F

Display	Item	Contents	Initial value	User level
U'-1	User function definition 1	This is the display in upper display. The setup exception is as follows: ---- : Yet to be registered.	----	1
U'-2	User function definition 2	P- : Proportional band of the PID group in use I- : Integration time of the PID group in use D- : Derivative time of the PID group in use rE- : Manual reset of the PID group in use	----	1
U'-3	User function definition 3	oL- : MV low limit of the PID group in use oH- : MV high limit of the PID group in use P- : Cool-side proportional band of the PID group in use	----	1
U'-4	User function definition 4	I- : Cool-side integration time of the PID group in use	----	1
U'-5	User function definition 5	d- : Cool-side derivative time of the PID group in use	----	1
U'-6	User function definition 6	oL- : Cool-side MV low limit of the PID group in use	----	1
U'-7	User function definition 7	oH- : Cool-side MV high limit of the PID group in use	----	1
U'-8	User function definition 8	oH- : Cool-side of MV high limit of the PID group in use	----	1

■ Lock bank

Bank selection: LoC

Display	Item	Contents	Initial value	User level
LoC	Key lock	0: All settings are enabled. 1: Mode, event, operation display, SP, UF, lock, manual MV, and mode key can be set. 2: Operation display, SP, UF, lock, manual MV, and mode key can be set. 3: UF, lock, manual MV, and mode key can be set.	0	0
C, LoC	Communication lock	0: RS-485 communication read/write is enabled. 1: RS-485 communication read/write is disabled.	0	2
L, LoC	Loader lock	0: Loader communication read/write is enabled. 1: Loader communication read/write is disabled.	0	2
PR55	Password display	0 to 15 5: Password 1A to 2B display	0	0
PS1A	Password 1A	0000 to FFFF (hexadecimal value)	0000	0
PS2A	Password 2A	0000 to FFFF (hexadecimal value)	0000	0
PS1B	Password 1B	0000 to FFFF (hexadecimal value)	0000	0
PS2B	Password 2B	0000 to FFFF (hexadecimal value)	0000	0

■ Instrument information bank

Bank selection: i'd

Display	Item	Contents	Initial value	User level
i'd01	ROM ID	0 : SDC15 1 : SDC25/26 2 : SDC35/36	2	2
i'd02	ROM version 1	XX.XX (2 digits after decimal point)	—	2
i'd03	ROM version 2	XX.XX (2 digits after decimal point)	—	2
i'd04	SLP support Information		—	2
i'd05	EST support version		—	2
i'd06	Manufacturing date code (year)	Year-2000. Ex.: "3" means the year 2003.	—	2
i'd07	Manufacturing date code (month, day)	Month + Day = 100 Ex.: "12.01" means the 1st day of December	—	2
i'd08	Serial No.		—	2



Specifications are subject to change without notice.

Yamatake Corporation
Advanced Automation Company

Totate International Building

2-12-19 Shibuya Shibuya-ku

Tokyo 150-8316 Japan

URL: http://www.yamatake.com

Printed in Japan.

1st Edition: Issued in Oct., 2003(A)

3rd Edition: Issued in Apr., 2004(E)

This has been printed on recycled paper. (02)