

DigitroniK Digital Indicating Controller SDC 31

The DigitroniK SDC 31 is a compact (96×96mm), digital indicating controller offering standard PID control and an advanced neural/fuzzy PID that performs process diagnostics and reduces overshoot.

The SDC 31 offers full, multi-range inputs, selectable from the keypad, including thermocouple, resistance temperature detector (RTD), DC voltage and DC current inputs. The SDC 31 provides a comprehensive range of strategies including time proportional PID (relay output, voltage output), current output PID, and position proportional PID. The controller also enhances process visibility with such functions as remote switch input, control parameters, and local set points, which can be easily set using the smart loader.



■ Features

- High accuracy of $\pm 0.2\%$ FS.
- Input types and ranges are selectable from the keypad.
- SP1 to SP8 can be selected by the operators.
- 8 groups of PID control constants are provided. Each PID group can be optimized using a range of configurable values.
- Neural/Fuzzy and conventional autotuning allows simultaneous implementation of the rising, disturbance responses, and overshoot prevention characteristics.
- Abnormal operation diagnostics allows automatic changeover of motors to their estimated stop position by detecting abnormal feedback resistance.
- Control loop diagnostics checks the output condition at PV change.

- PV bias and RSP bias can be set.
 - The setpoint value ramp function allows setting of the SP change ratio.
 - Two event outputs are provided: enabling one with a timer function, and a motor opening event to be set.
 - The operation modes are selectable by external switch inputs (local/remote, auto/manual, RUN/READY, selection of 8 local set points, AT start, direct/reverse action timer event start).
 - Versatile optional functions support a broad range of applications:
 - ★ Events (2 points)
 - ★ Auxiliary output (1 point)
 - ★ Digital input (4 points)
 - ★ Communication (RS-485)
 - CE marking compliant
- Adaptive standards: EN61010-1, EN50081-2, EN50082-2

■ Basic Functions Block Diagram

• Standard Model and Remote SP Model

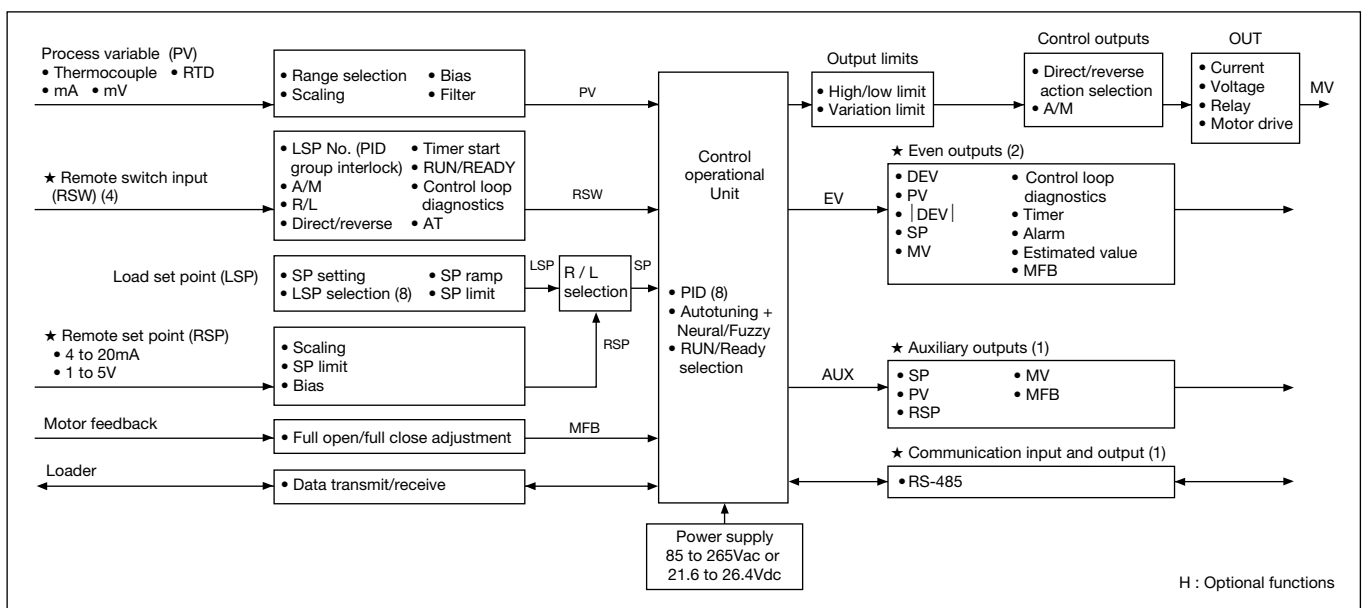

■ Specifications

PV input	Type of input	Multi range thermocouple, resistance temperature detector, DC voltage and DC current.				
	Sampling cycle	0.2s				
	Input bias	-1 000 to +1 000U variable: U: °C, kgf/cm ² , G, % and other industrial units, including decimal point positioning				
	Input digital filter	0.0 to 25.0s variable				
	Input bias current	Thermocouple input: 0.16µA max. (Applicable to models other than those for RT50) ±0.02µA max. (Applicable to models for RT50)	Note: 1 Applicable to models other than those for RT50 Note: 2 When the resistor or A line is broken: Upscale + alarm When B line is broken: Downscale + alarm When C line is broken: Undefined indication + alarm When A and B lines are broken: Upscale + alarm When B and C lines are broken: Upscale + alarm When A and C lines are broken: Upscale + alarm When A, B and C lines are broken: Upscale + alarm Note: 3 For 0 to 20mA inputs, burnout can not be detected.			
		RTD input: 1mA				
		DC voltage input: -0.6µA min				
		Current input: 100 Ω ±1%				
	Input impedance	Current input: 100 Ω ±1%				
	Allowable wiring resistance	Thermocouple input: 0.16µV/Ω max. (Applicable to models other than those for RT50) ±0.02µV/Ω max. (Applicable to models for RT50)				
	RTD input: -100 to +200°C range: ±0.036%FS/Ω max. -200 to +500°C range: ±0.064%FS/Ω max.					
Burnout	Thermocouple input: Upscale + alarm indication (see note 2)					
	RTD input (see note 2)					
	DC voltage input: Downscale + alarm indication					
	DC current input: Downscale + alarm indication (see note 3)					
Data display and setting	Indication method	4-digit and 7-segment LED indication				
	OK lamp	Control deviation status is shown in a "green belt".				
	Number of setting points	1 to 8 points. Optional selection and changeover use are enabled.				
	Data storage	Non-volatile EPROM				
	Range	Thermocouple or RTD input (see Table 1). DC voltage or current (programmable range) input: -1999 to 9999, to 3 decimal places.				
	Accuracy	±0.2%FS ± 1digit for display (except for thermocouple B ranged between 0 and 260°C). 0 to 10mV input: ±0 ±0.3%FS ± 1digit				
	Resolution	Thermocouple or RTD input: 1, 0.1°C (depending on input type) DC voltage or current (programmable range) input: 1, 0.1, 0.01, 0.001 (depending on input type)				
	Setting system	Local: Standard Remote: Option function (remote/local changeable)				
	Control output	Model number	C310D	C316D	C315G	C312G
Output type		SPDT relay contact	Voltage	Current (4 to 20mA)	Relay contact to drive Modutrol motors	
Control action		Time proportional PID	Time proportional PID	Continuous PID	Position proportional PID	
Number of PID sets		8 sets	8 sets	8 sets	8 sets	
PID automatic selection		One of 8 PID sets is automatically selected using max. 8 zones where LSP or RSP is located.				
PID autotuning		Automatic setting of PID values by limit cycle method and neural/fuzzy learning/smart method				
Output rating		Contact type: SPDT Resistive load: 250Vac, 5A	Open voltage: 22.5Vdc ± 15% Internal resistance: 1120Ω ±5%	Output current: 4 to 20mA Load resistance: 750Ω max. Output accuracy: 0.2% under standard conditions Output resolution: 0.01% min Output update cycle: 0.2s	Contact type: 2SPST Resistive load: 250Vac, 8A Inductive load: 250Vac, 3.5A Feedback resistance: 100 to 2500Ω	
Proportional band (P): % FS		0.0 to 99.9 (ON/OFF operation at P=0.0)	0.1 to 999.9 (ON/OFF operation at P=0.0)	0.0 to 999.9 (ON/OFF operation disabled)	0.1 to 999.9 (ON/OFF operation disabled)	
Cycle time: sec.		5 to 120	1 to 120	—	—	
Integral time (I): sec.		0 to 3600 (PD action at I=0)	0 to 3600 (PD action at I=0)	0 to 3600 (PD action at I=0)	0 to 3600 (PD action at I=0)	
Derivative time (D): sec.		0 to 1200 (PI action at D=0)	0 to 1200 (PI action at D=0)	0 to 1200 (PI action at D=0)	0 to 1200 (PI action at D=0)	
Manual reset: %		0 to 100	0 to 100	0 to 100	0 to 100	
Differential gap: U		0.0 to 100 (when ON/OFF operation)	0.0 to 100 (when ON/OFF operation)	—	—	
Output limiter %		Lower limits	0 to high limit	0 to high limit	0 to high limit	0 to high limit
		Upper limits	low limit to 100	low limit to 100	low limit to 100	low limit to 100
Output action changeover		Direct/reverse changeover is enabled.				
Deadband: % out		—				
Manipulated variable change ratio limit: %	0.0 to 100.0 (every 0.2s)	0.0 to 100.0 (every 0.2s)	0.0 to 100.0 (every 0.2s)	0.0 to 100.0 (every 0.2s)		

Control output	Modutrol motor control system	<p style="text-align: center;">—</p>			<p>Any of the following three systems are selectable</p> <ul style="list-style-type: none"> • Motor feedback provided. (see note 4) • Motor feedback provided (see note 5) • No motor feedback provided. 		
		<p>Notes: 4 Control is based on the specified motor feedback resistance value from which abnormal values have been rejected. This mode automatically changes to the control without motor feedback, when the motor feedback resistor T line is broken.</p> <p>5 Control is based on the specified motor feedback resistance value from which abnormal values are not rejected. This mode automatically changes to the control without motor feedback, when the T line is broken.</p>					
Set point ramp	Function	Sets the set point change ratio.					
		Range	0 to 9999U/min, 0 to 999.9U/min, 0 to 9999U/h, 0 to 999.9U/h				
Set point ramp	Setting	The SP ramp does not function when the set point value is 0, LSP is changed to RSP, or the instrument is operated by RSP.					
Optional function	Event (EV)	Number of outputs	2 points (standard)				
		Types of event	Direct deviation	Reverse deviation	Direct PV	Reverse PV deviation value	Direct absolute
			Reverse absolute deviation value	Direct SP	Reverse SP	Direct MV	Reverse MV
			Direct motor feedback	Reverse motor feedback	Control loop diagnosis (Note 6)	Timer (s)	Timer (min)
		Direct alarm	Reverse alarm	Presumed position execution (Note 7)	<p>Note: 6 Control loop diagnostic event This turns ON, when the event ON lag is exceeded, but the temperature does not rise beyond the differential gap (does not fall if direct action) though a manipulated variable value is larger than the set output value (0 to 100%) for this event.</p> <p>Note: 7 Presumed position execution event This turns ON when the instrument is changed to the presumed position control due to motor feedback resistor breakage.</p>		
		Setting range	Deviation (direct, reverse): Within \pm PV range/2 (within -1999U) PV (direct, reverse): Within PV range Absolute deviation value (direct, reverse): 0 to PV range/2 SP (direct, reverse): Within SP limit MV (direct, reverse): -10.0 to +110.0% Motor feedback (direct, reverse): 0.0 to 100.0% Control loop diagnosis: 0.0 to 100.0% Timer (s or min): 1 to 9999s or min				
		Differential gap	0 to 100U (This cannot be set when the event type is alarm, timer, or presumed position execution)				
		On delay time	0 to 999s (This cannot be set when the event type is timer or presumed position execution)				
Standby sequence	Presence or absence selectable. (This cannot be set when the event type is alarm, timer or presumed position execution)						
Output rating	SPST relay contact, 250Vac, 30Vdc, 5A, resistive load						

Optional function	Remote switch input (RSW)	Number of input points	4 points selectable.			
		Function	Allocates an optional function selectively from SP (PID interlock), RUN/READY, AUTO/MANUAL, LOCAL/REMOTE, autotuning start, direct/reverse, and timer start.			
		Input rating	Dry contact or open collector transistor. OFF-terminal voltage: $5 \pm 1V$, ON current: $5 \pm 2mA$			
	Auxiliary output (AUX)	Number of AUX points	1 point			
		Output type	Selectable from process variable (PV), set point (SP), remote set point, remote set point before bias, control output, and motor open.			
		Output rating	4 to 20mA _{dc} Load resistance: 750Ω max.			
		Output accuracy	$\pm 0.2\%$ FS (under standard conditions)			
		Output resolution	0.01% min.			
	Remote set point (RSP)	Output update cycle	0.2s			
		Types	4 to 20mA _{dc} or 1 to 5V _{dc} , depending on controller.			
		Accuracy	$\pm 0.2\%$ FS (± 1 digit under standard conditions)			
		Sampling cycle	0.2s			
	Communication	Communication system	Bias	-1999 to +9999U		
			Communication protocols	RS-485		
			Network	Multidrop The device is provided only with the slave station function. 1 to 16 units max. (DIM), 1 to 31 units max. (CMA, SCM).		
		Interface system	Data flow	Half duplex		
			Synchronization	Start/stop synchronization		
			Transmission system	Balanced (differential)		
			Data line	Bit serial		
			Signal lines	5 transmit/receive lines (3-wire connection is also possible with DIM)		
			Transmission speed	1200, 2400, 4800, 9600bps		
			Communication distance	300m max. (DIM), 500m max.		
			Others	Correspond to RS-485		
		Message characters	Character configuration	11 bits/character		
			Format	1 start bit, even parity, and 1 stop bit, or 1 start bit, no parity, and 2 stop bits		
			Data length	8 bits		
		Isolation	Completely isolated between the input and output except external switch input.			
Note: For RS-485 communication, the device can be connected to Yamatake's MX200, MA500 (DK link II DIM) or CMA50 controllers.						
General specifications	Memory backup	Non-volatile EEPROM				
	Rated power	100 to 240Vac, 50 to 60Hz (AC power supply model), 24V _{dc} (DC power supply model)				
	Operating power	85 to 264Vac, at 50Hz: $50 \pm 2Hz$, at 60Hz: $60 \pm 2Hz$ (AC power supply model), 21.6 to 26.4V _{dc} (DC power supply model)				
	Inrush current	30A max. (AC power supply model), 20A max. (DC power supply model)				
	Power consumption	18VA max. (operating)				
	Insulation resistance	More than 50MΩ between the case or ground terminal and power terminal by 500V _{dc} megger				
	Dielectric strength	1500Vac for 1 min between the case or ground terminal and power terminal (AC power supply model), 500Vac 1 min (DC power supply model).				
	Operating conditions	Operating temperature	0 to 50°C			
		Operating humidity	10 to 90%RH			
		Vibration resistance	2.0m/s ² max.			
		Shock resistance	9.8m/s ² max.			
	Transport / storage conditions	Storage temperature	-20 to +70°C			
		Storage humidity	10 to 95%RH			
		Vibration resistance	4.9m/s ² max., 10 to 60Hz, for 2h each in X, Y and Z directions.			
		Shock resistance	490m/s ² max., 3 times in vertical direction when in box.			
	Package drop test	Drop height 90cm (1 angle, 3 edges, 6 planes, free fall)				
	Construction	Mask: Multiton Case: Polycarbonate				
	Colors	Mask: Dark gray Case: Light gray				
	Mounting	Panel flush mount				
	Installation	Vertical plane $\pm 15^\circ$				
Weight	Approx. 500g					
Attachments	Item	Model No.	Quantity	Options	Item	Model No.
	Unit indicating label	N-3132	1 sheet		Hard dustproof cover	81446083-001
	Mounting bracket	81405411-001	2 pcs.		Soft dustproof cover	81446087-001
	Instruction Manual	No. CP-UM-1586E	1 block		Terminal cover	81446084-001

Table 1 Types of Inputs and Ranges (selectable at keypad)

Type of input	Symbol	°C range	°F range	Type of input	Symbol	°C range	°F range
Thermocouple	K (Note 1)	0 to 1200	0 to 2200	Thermocouple	Ni-M ₀	0 to 1300	32 to 2372
		0.0 to 800.0	0 to 1400		DIN U	-199.9* to +400.0	-300 to +700
		-199.9* to +400.0	-300 to +700		DIN L	0.0 to 800.0	0 to 1400
	J	0 to 1200	0 to 2000	RTD	JIS Pt100	-199.9* to +500.0	-300 to +700
		0.0 to 800.0	0 to 1400			-100.0 to +200.0	-150.0 to +400.0
		-199.9* to +400.0	-300 to +700		JIS JPt100	-199.9* to +500.0	-300 to +700
	E	0.0 to 800.0	0 to 1400	DC current, voltage	4 to 20mA	Scaling setting range -1999 to +9999 (Decimal point position is not fixed.)	
	T	-199.9* to +400.0	-300 to +700		0 to 20mA		
	R	0 to 1600	0 to 3000		1 to 5V		
	S	0 to 1600	0 to 3000		0 to 5V		
	B	0 to 1800	0 to 3200		0 to 10mV		
	N	0 to 1300	32 to 2372		0 to 100mV		
	PLII	0 to 1300	32 to 2372		-10 to +10mV		
	WRe5-26	0 to 2300	0 to 4000				
WRe0-26	0 to 2300	0 to 4000					

Note 1. The RT50 output performance is same as K thermocouple.

Note 2. (*) Although -200.0 cannot be set nor indicated, the calibration has been performed at -200.0°C.

Model Selection Guide

I **II** **III** **IV** **V** **0** Example: C312GA000100

I	II	III	IV	V	Contents (○: Included —: Not Included)												
Basic model number	Control action	Power supply	Optional function	Additional processing													
C31					Digital controller												
	0D				Time proportional PID: Relay contact, 250Vac, 5A, resistive load												
	6D				Time proportional PID: Voltage 22.5Vdc ± 15%												
	5G				Continuous PID: Current 4 to 20mA, resistive load 570Ω max.												
	2G				Position proportional PID: MM drive relay contact, 250Vac, 8A (resistive load), 3.5A (indicative load)												
	A0				85 to 264Vac, 50 to 60Hz												
	AZ				85 to 264Vac 50 to 60Hz, apply to RT50												
	D0				21.6 to 26.4Vdc												
	DZ				21.6 to 26.4Vdc, apply to RT50												
					Event		Auxiliary output	Remote setting input		Remote switch input		Communications		RT50 applicability (Note 1)			
					EV1	EV2	AUX	RSP (4 to 20mA)	RSP (1 to 5V)	RSW (1 point)	RSW (4 points)	RS-485	0D	6D	5G	2G	
	001				○	○	—	—	—	—	—	—					
	003				○	○	—	—	—	—	○	—					
	005				○	○	○	—	—	—	○	—					
	045				○	○	○	—	—	—	○	○					
	405				○	○	○	○	—	—	○	—		—			
	446				○	○	○	○	—	—	—	○		—			
	505				○	○	○	—	○	—	○	—		—			
	546				○	○	○	—	○	—	—	○		—			
	0				Not provided.												

- Note 1. Apply to inputs other than RT50. (Select AO at III)
 Apply to all inputs including RT50. (Select AZ at III)
 Function not supported.

■ Dimensions

[in mm]

C31 Controller

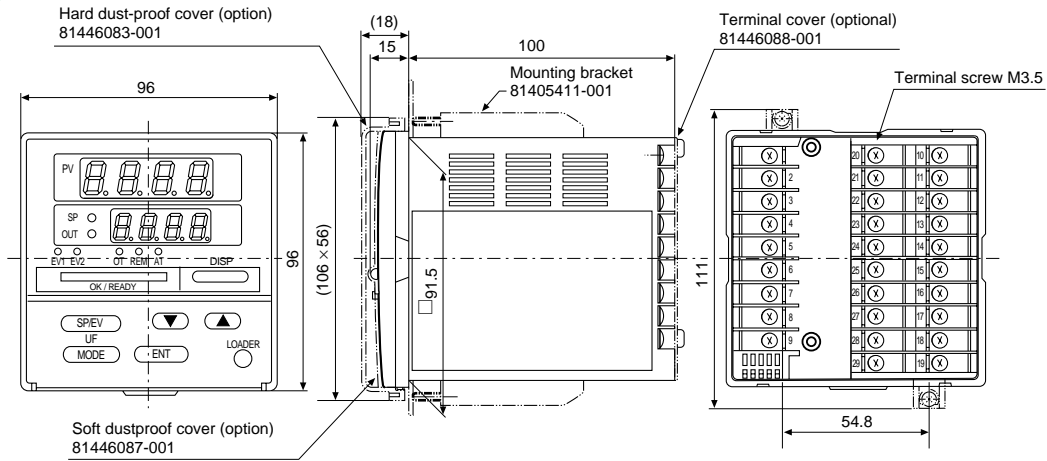

Soft dust-proof cover Part No. 81446087-001

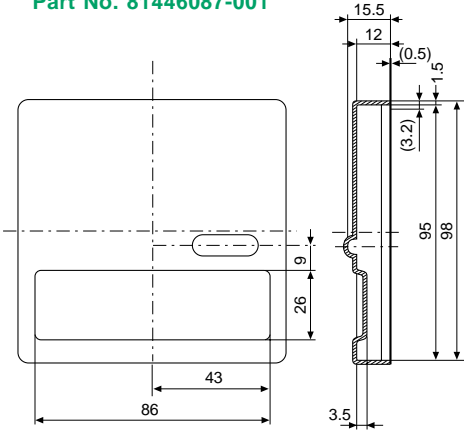

Hard dust-proof cover Part No. 81446083-001

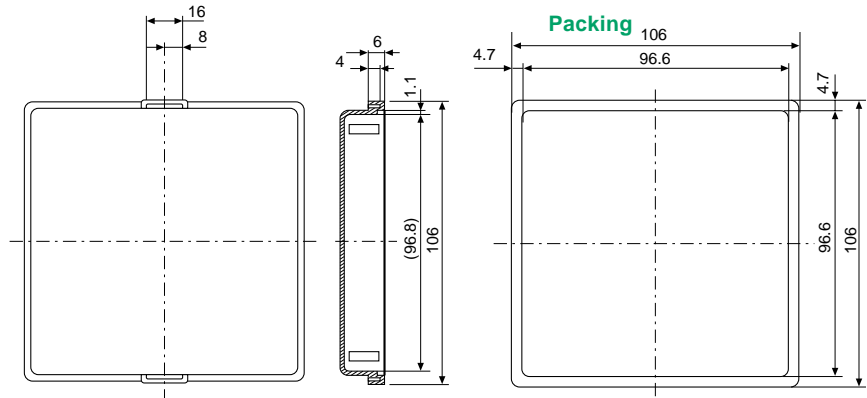

Terminal cover Part No. 81446084-001

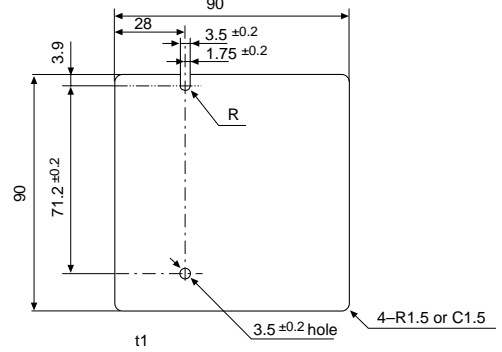

Panel Cutout

For standard application or
with soft dust-proof cover

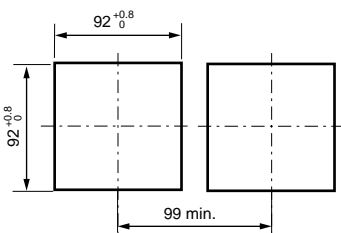

When the hard dust-proof
cover is used

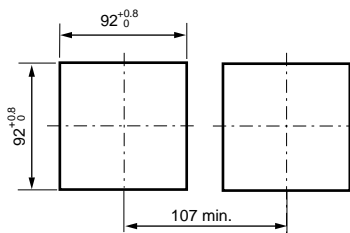

Serial mounting

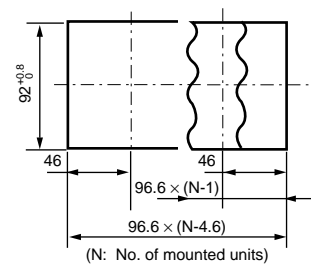

Wiring

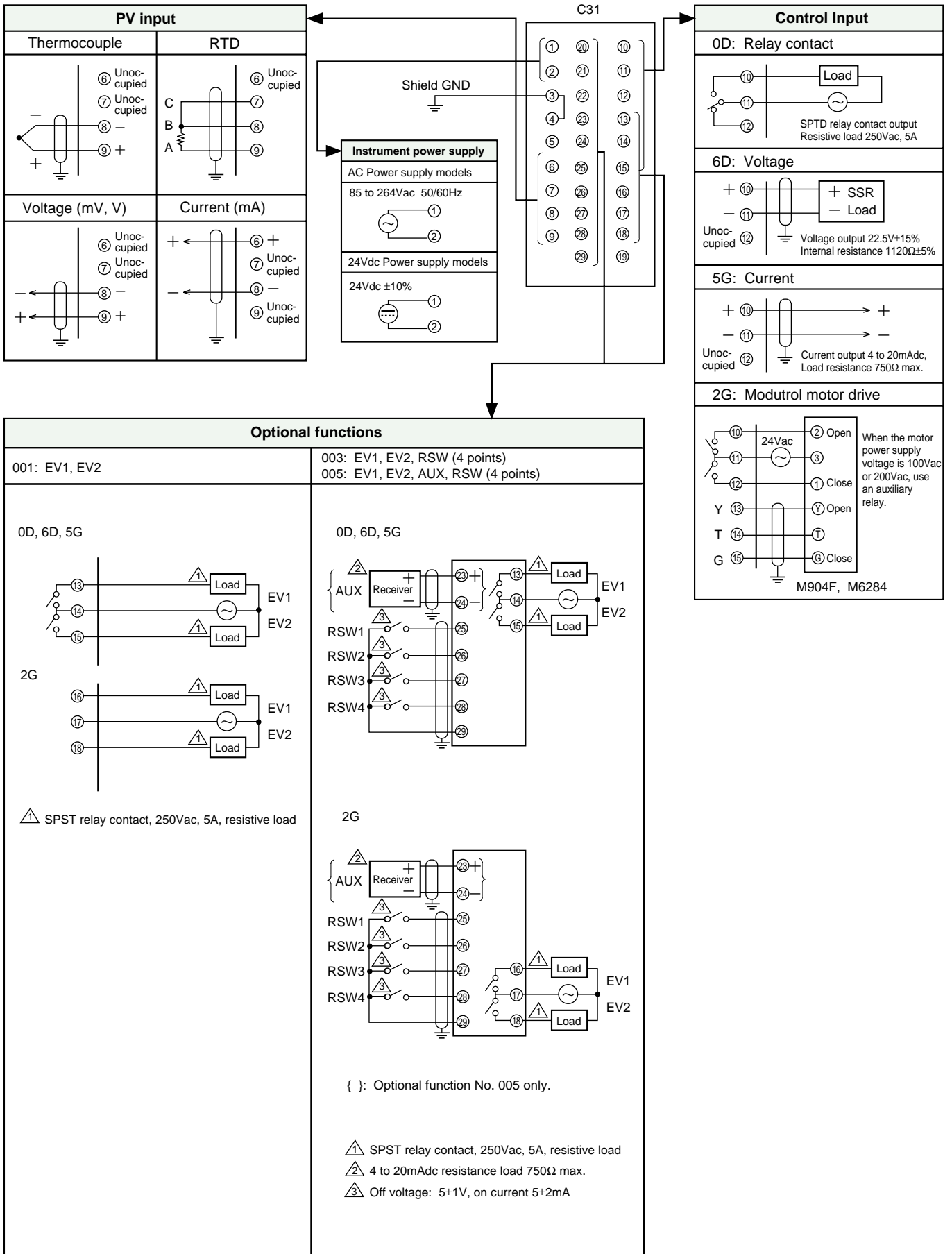

Optional functions

045: EV1, EV2, AUX, RSW (4 points), RS-485

405: EV1, EV2, AUX, RSP, RSW (4 points)
505: EV1, EV2, AUX, RSP (1 to 5V), RSW (4 points)

446: EV1, EV2, AUX, RSP (4 to 20mA), RS-485
546: EV1, EV2, AUX, RSP (1 to 5V), RS-485

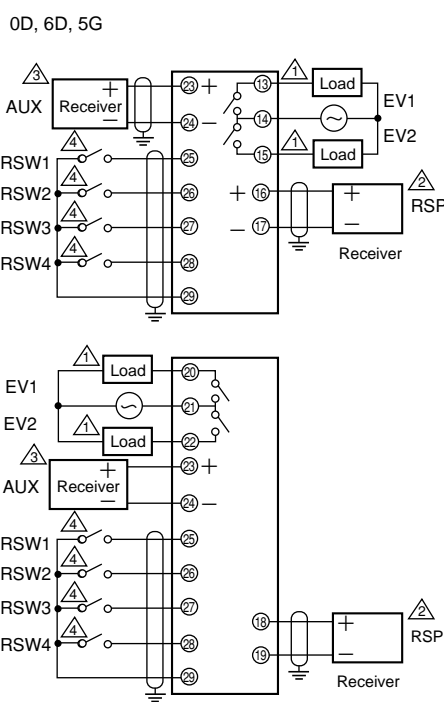
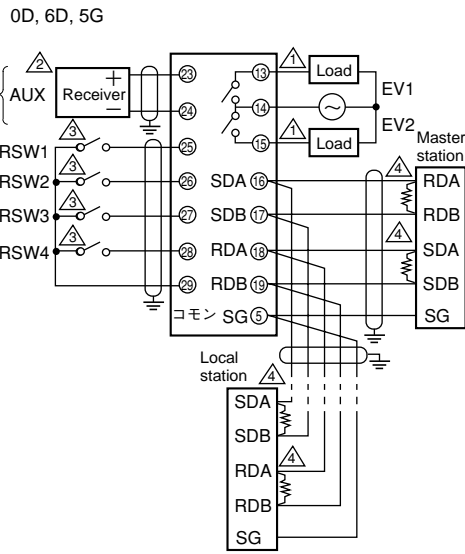

Note. When making three-wire system connection in the RS-485 type, short circuit between SDA and RDA, and between SDB and RDB of this instrument.

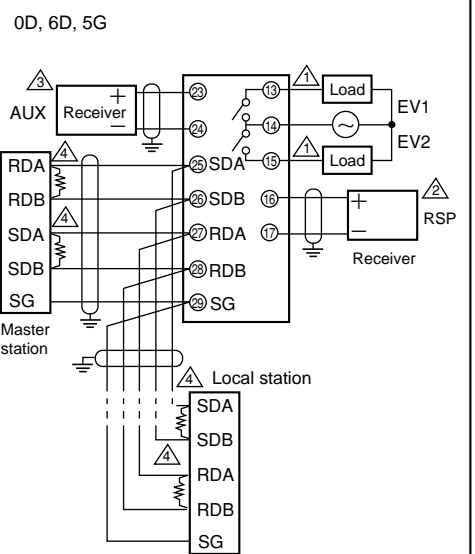
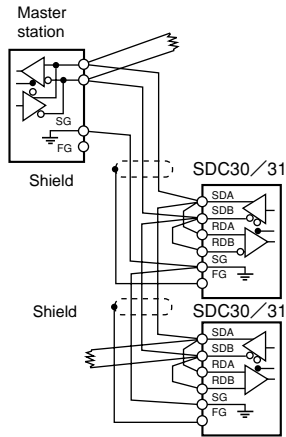

2G

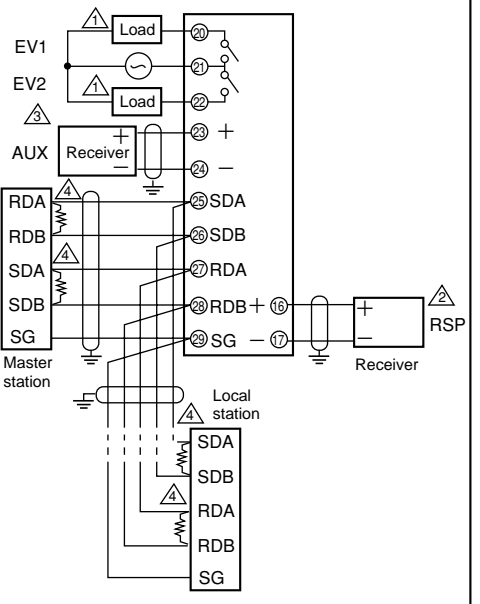

- △ SPST relay contact 250Vac, 5A, resistive load
 - △ 4 to 20mAdc, load resistance 750Ω max.
 - △ Off voltage: 5±1V, on current: 5±2mA
 - △ Terminating resistance: 150Ω 1/2W min.
- Connect one each terminating resistance between SDA and SDB, and between RDA and RDB

- △ SPST relay contact 250Vac, 5A, resistive load
- △ 1 to 5Vdc (505), 4 to 20mAdc (405)
- △ 4 to 20mAdc, load resistance 750Ω max.
- △ Off voltage: 5±1V, on current 5±2mA

- △ SPST relay contact 250Vac, 5A, resistive load
 - △ 1 to 5Vdc (546), 4 to 20mAdc (446)
 - △ 4 to 20mAdc, load resistance 750W max.
 - △ Terminating resistance: 150Ω 1/2W min.
- Connect one each terminating resistance between SDA and SDB, and RDB

■ Cautions for wiring

1. Isolation

The section bounded by a solid line (——) is isolated from the rest of the circuit.

The section bounded by a dotted line (----) is not isolated from the rest of the circuit.

Loader interface	Digital circuit	Motor feedback Potentiometer input
Remote setting input		Current output (Control output)
PV input	Digital circuit	Current output (Auxiliary output)
		Voltage output (Control output)
		Relay output (Control output)
Remote switch input	Digital circuit	Event output 1
		Event output 2
		Communication I/O

2. Power supply noise

(1) Noise reduction techniques

Always use a noise filter to suppress the influence of noise as much as possible, even if noise is unnoticeable.

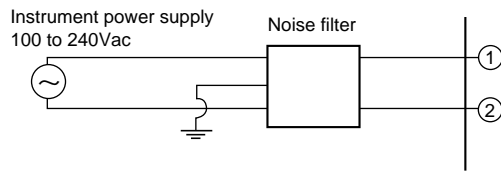

(2) When noise is evident

If noise is observable, suppress it by using an insulation transformer and line filter.

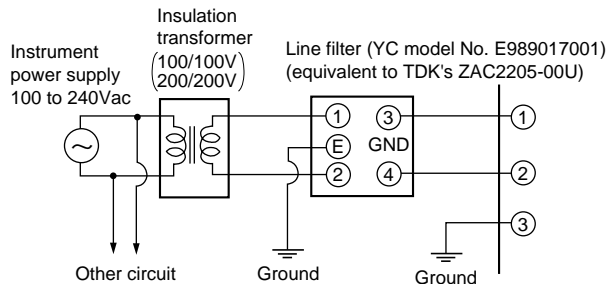

3. Noise

Possible noise sources in the installation environment are:

Relays and contacts, electromagnetic coils, solenoid valves, power lines (specifically, those higher than 100Vac), motor commutators, phase angle control SCRs, radio equipment, welding machines, high-voltage ignition devices, etc.

(1) Suppression techniques for quick rising noise

A CR filter is effective for quick rising noise.

Recommended filter: Matsuo Electric 953M50033331

(2) Suppression technique, for noise with large peaks:

A varistor is effective for reducing noise with large peaks. However, care should be taken to avoid shorting if varistor is faulty.

4. Grounding

Ground this controller at a single point to GND terminal ③ to ④. Don't connect any jumper wiring. Prepare a grounding terminal board separately if grounding of a shield wire is difficult.

Grounding type: At least category 3 (100Ω max.)

Grounding wire: Soft steel wire (AWG14) of more than 2mm².

Grounding wire length: 20m max.

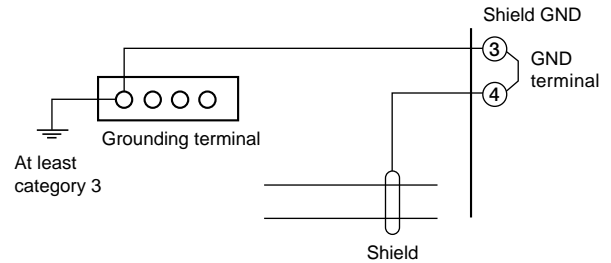

5. Wiring operations

- Don't bundle the primary and secondary power lines together, and don't run them in the same wiring conduit or duct after carrying out noise countermeasures.
- Run the input/output and communication lines more than 50cm from drive power or power lines of higher than 100Vac. Don't run these wires in the same wiring conduit or duct.

6. Check after wiring

After wiring, be sure to check the connecting line conditions. Be careful: incorrect wiring will cause the instrument to fail.

 **RESTRICTIONS ON USE**

This product has been designed, developed and manufactured for general-purpose application in machinery and equipment. Accordingly, when used in the applications outlined below, special care should be taken to implement a fail-safe and/or redundant design concept as well as a periodic maintenance program.

- **Safety devices for plant worker protection**
- **Start/stop control devices for transportation and material handling machines**
- **Aeronautical/aerospace machines**
- **Control devices for nuclear reactors**

Never use this product in applications where human safety may be put at risk.

Specifications are subject to change without notice.

YAMATAKE

Yamatake Corporation
Advanced Automation Company
International Business Headquarters

Totate International Building
2-12-19 Shibuya Shibuya-ku
Tokyo 150-8316 Japan
URL:<http://www.yamatake.com>

This has been printed on recycled paper. (01)

Printed in Japan. (H)
1st Edition: Issued in May, 1994
4th Edition: Issued in Feb., 2003