

DigitroniK Digital Indicating Controller SDC20

The DigitroniK SDC 20 is a compact digital controller with multi-range and PID autotuning systems for various inputs, with time proportional (on/off) PID and continuous PID control action.

The SDC 20 sends relay contact, voltage, current, and the signals from other variables as control output signals.

The controller also enhances process visibility with such functions as remote switch input, control parameters, and local set points, which can be easily set using the smart loader.



■ Features

- Accuracy of $\pm 0.3\%$ FS.
- Type of inputs and ranges can be selected by key operation.
- Two points can be set concurrently.
- Autotuning system with two groups of PID control constants.
- Normal and abnormal operations are indicated by an OK lamp for easy decision making.
- SP ramp setting function allows the ratio of each set point value to be changed.
- Four modes of action can be selected using remote switch inputs.
- Compact and lightweight (Dimensions; 48 x 96 x 115mm Weight; 400g)
- Optional functions ensure a wide range of applications:
 - ★ Event outputs (UP to 2 points) ★ Heater burnout alarm
 - ★ Auxiliary outputs ★ RS-232C/485 Communications
- CE Marking compliant
Applicable standards: EN 61010-1, EN 50081-2, EN 50082-2

■ Basic Function Block Diagram

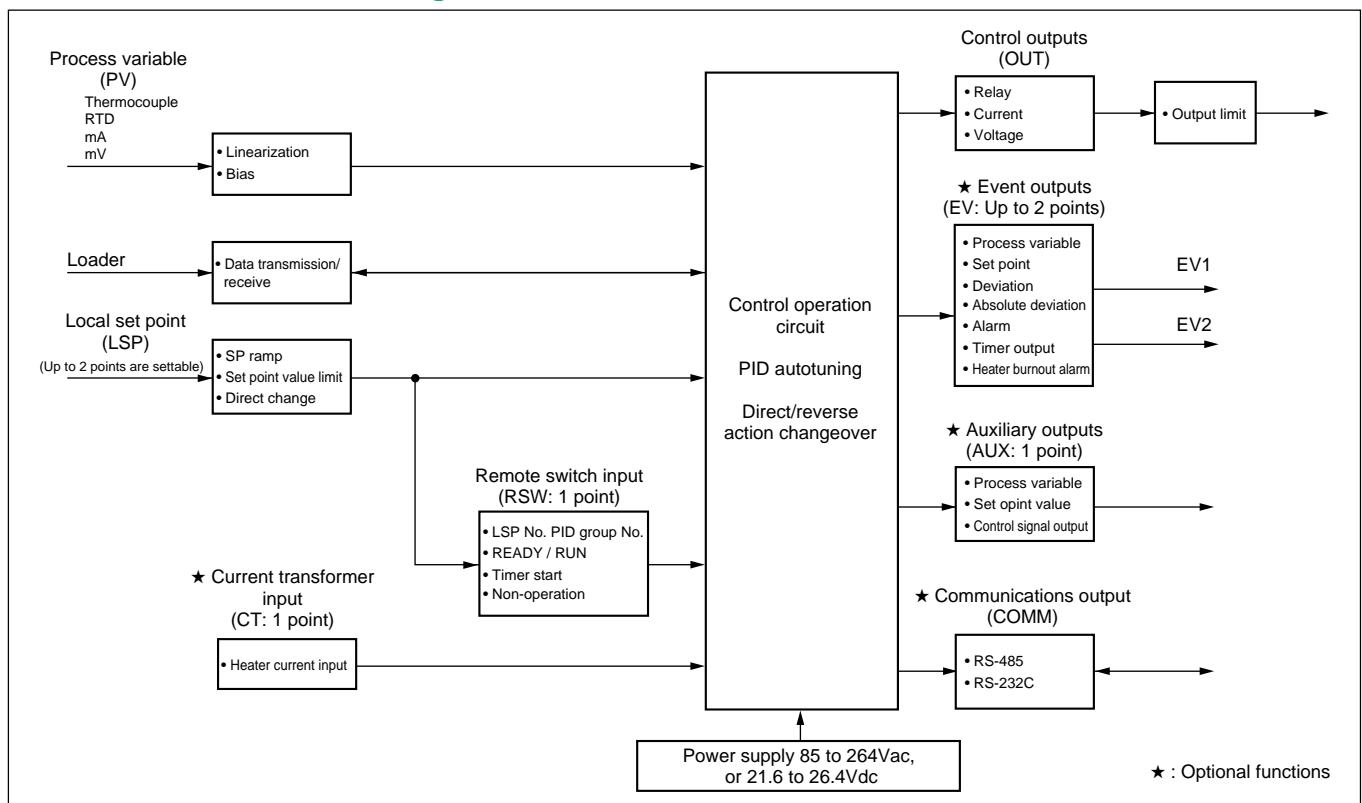

■ Specifications

PV input	Type of input	Multi range thermocouple, resistance temperature detector. DC voltage, and DC current.			
	Sampling cycle	0.5 sec			
	Input bias	Variable within -100 to +100U. U: °C, kgf/cm ² G{kPa}, %, and others industrial units including decimal point positioning.			
	Input impedance	Thermocouple input	: 0.13μA		
		RTD input	: 1μA		
		DC voltage input	: -0.3μA		
		Current input	: 100Ω max.		
	Allowable wiring resistance	Thermocouple input	: 0.14μV/Ω max.		
		RTD input	: ±0.01%FS/Ω max.		
	Burnout	Thermocouple input	: Upscale+Alarm indication		
RTD input		: (See Note 1)			
DC voltage input		: Downscale + Alarm indication			
DC current input		: Downscale + Alarm indication			
Note 1: When the resistor or A line is broken: Upscale + Alarm indication When B line is broken: Down scale + Alarm indication When C line is broken: Undefined indication + Alarm indication When A and B lines are broken: Upscale + Alarm indication When B and C lines are broken: Upscale + Alarm indication When A and C lines are broken: Upscale + Alarm indication When A, B, and C lines are broken: Upscale + Alarm indication					
Data display and setting	Indication method	4 digit, 7 segment LED indication			
	OK lamp	The control deviation value status is indicated by the green belt.			
	Number of setting points	1 to 2 points. Optional selection and changeover use are enabled.			
	Data storage	Non-volatile EPROM			
	Range	Thermocouple or RTD input (see Table 1)			
		DC voltage or current (programmable range) input: -1999 to +9999 to 3 decimal places.			
	Accuracy	±0.3%FS±1 digit for display, except for thermocouple B ranged between 0 and 260°C.			
	Setting range	Thermocouple or RTD input: 1, 0.1°C or 1, 0.1°F (depends on input type)			
DC voltage or current (programmable range) input: 1, 0.1, 0.01, 0.001 (depends on input type).					
Setting system	Local standard: Direct change is enabled. (see Note 2)				
	Note 2: LSP direct change: This function can change the LSP (local set point) without defining operation by the ENT key.				
Control output	Model number	SDC 200D	SDC 206D	SDC 205G	
	Output type	Relay contact	Voltage	Current	
	Control action	Time proportional PID	Time proportional PID	Continuous PID	
	Number of PID sets	2 sets	2 sets	2 sets	
	PID autotuning	Automatic setting of PID value by limit cycle method.			
	Output rating	Contact type: SPDT	Open voltage: 22.5Vdc±15%	Output current: 4 to 20mA dc	
		Resistive load: 250Vac, 5A	Internal resistance: 1.5kΩ±10%	Load resistance: 600Ω max. Output accuracy: 0.2% on standard conditions Output resolution: Within 0.01% Output update: 0.5sec	
	Proportional band (P): %FS	0.0 to 999.9 (on/off operation at P=0.0)	0.0 to 999.9 (on/off operation at P=0.0)	0.1 to 999.9 (on/off operation disabled)	
	Cycle time: sec	5 to 120	1 to 120	—	
	Integral time (I): sec	0 to 3600 (PD action at I=0)	0 to 3600 (PD action at I=0)	0 to 3600 (PD action at I=0)	
	Derivative time (D): sec	0 to 1200 (PI action at D=0)	0 to 1200 (PI action at D=0)	0 to 1200 (PI action at D=0)	
	Manual reset: %	0 to 100	0 to 100	0 to 100	
	Differential gap: U	0 to 100 (when on/off operation)	0 to 100 (when on/off operation)	—	
	Output limiter %	Low-limit value	0 to high limit	0 to high limit	-10 to high limit
		High-limit value	low limit to 100	low limit to 100	low limit to 100
	SP ramp	Function	Sets the change rate of set value		
		Range	0 to 9999U/min.		
Setting		Setting of the rising rate of initial PV with respect to SP. Valid when SPU ≠ 0 (SPU: Set Point Up)	Setting of the falling rate of initial PV with respect to SP. Valid when SPD ≠ 0 (SPD: Set Point Down)		
Remote switch input (RSW)	Number of input points	1 point			
	Function	Allocates an optional function selectively from among: LSP No.: PID group No. (interlock), READY/RUN changeover, timer start, and timer non-operation			
	Input rating	Dry contact or open collector transistor, Off-terminal voltage: 5±1V, Turn-on current: 5±2mA			

Optional functions	Event (EV)	Number of output points	1, or 2 points selectable				
		Even type setting range	Event type	Symbol	Setting range	Differential gap	Remarks
			Process variable	PV	within PV rang	0 to 100U	—
			Set point	SP	within SP limit	0 to 100U	—
			Deviation	DEV	±PV range/2	0 to 100U	-1999U min.
			Absolute deviation	DEV	0 to PV span/2	0 to 100U	—
			Alarm	—	—	—	—
			Timer	—	1 to 9999sec	—	By remote switch input
		Heater burnout alarm	HB	0.0 to 50.0A	0 to 100U	By Optional function HB	
		Output action	On/off				
	Output rating	SPDT relay contact, 240Vac, 5A, resistive load					
	Standby sequence	Presence or absence is selectable.					
	Heater burnout alarm (HB)	Number of input points	1 point				
		Maximum measurement heater current	Single phase, 50Aac				
		Current indicating accuracy	±5%±1U				
		Detection setting range	0.1 to 49.9A				
		Output	Output relay can be EV1 or EV2.				
	Auxiliary output (AUX)	Number of output points	1 point				
		Output type	One type is selectable from process variable (PV), set point (SP) and control output (OUT).				
		Output rating	4 to 20mAdc. Load resistance: 600Ω max.				
		Output accuracy	±0.2%FS (under standard conditions)				
		Output update cycle	500ms				
	Communication	Communication system	Communication standard	RS-485		RS-232C	
			Network	1 to 16 units max. multi-dropped (slave mode only).		Peer-to-peer (slave mode only).	
			Mode	Half duplex		Half duplex	
			Synchronization	Start/stop		Start/stop	
		Interface system	Transmission	Balanced (differential)		Unbalanced	
Type			Serial		Serial		
Signal lines			5 transmit/receive lines		3 transmit/receive lines		
Transmission speed			1200, 2400, 4800, or 9600bps selectable.		1200, 2400, 4800, or 9600bps selectable.		
Communication distance			300m max.		15m max.		
Other			Conforms to RS-485		Conforms to RS-232C		
Message character		Character configuration	11 bits/character		11 bits/chara		
		Format	1 start bit, even parity, and 1 stop bit (standard), or 1 start bit, no parity, 2 stop bits		1 start bit, even parity, and 1 stop bit (standard), or 1 start bit, no parity, 2 stop bits		
		Data length	8-bits		8-bits		
Isolation		Input and output completely isolated, except for the remote switch input.					
General specification		Memory backup	EPROM				
	Rated power voltage	100 to 240Vac, 50 to 60Hz; 24Vdc					
	Operating power voltage	85 to 264Vac at 50Hz: 50±2Hz at 60Hz: 60±2Hz; 21.6 to 26.4Vdc					
	Power consumption	16VA max. under operating conditions.					
	Insulation resistance	More than 50MΩ between the case or ground terminal and power terminal by 500Vdc megger.					
	Dielectric strength	1500Vac, 1 min (ac model), 500V 1 min (dc model) between the case or ground terminal and power terminal.					
	Operating conditions	Operating ambient temperature	0 to 50°C				
		Operating ambient humidity	10 to 90%RH				
		Vibration resistance	2.0m/s ² max.				
		Shock resistance	9.8m/s ² max.				
		Transport/storage conditions	Storage ambient temperature	-20 to +70°C			
	Storage ambient humidity		10 to 95%RH				
	Vibration resistance		4.9m/s ² max. 10 to 60Hz, for 2hr each in X, Y and Z directions.				
	Shock resistance		490m/s ² max., 3 times vertically when packaged.				
	Package drop test		Drop height: 90cm (1 angle, 3 edges, and 6 planes, free fall)				
	Construction	Mask: Multilon	Case: Polycarbonate				
	Colors	Mask: Dark gray	Case: Light gray				
	Mounting	Panel flush mount					
	Installation	Vertical plane ±15°					
	Weight	Approx. 400g					

Attachments	Item	Model No.	Quantity	Options	Item	Part No.	Weight
	Unit indicating label	N-3132	1 sheet		Hard dustproof cover	81446082-001	—
	Mounting bracket	81405411-001	2 pcs		Soft dustproof cover	81446086-001	—
	Instruction manual	CP-UM-1470E	1 book		Terminal cover	81446088-001	—
	—	—	—		Current transformer (5.8φ hole)	QN206A	Approx. 12g
—	—	—	Current transformer (12φ hole)	QN212A	Approx. 50g		

Table 1 Types of Inputs and Ranges (Selectable at setup)

Type of input	Symbol	°C range	°F range	Type of input	Symbol	°C range	°F range
Thermocouple	K	0 to 1200	0 to 2200	Thermocouple	Ni-Mo	0 to 1300	32 to 2327
		0.0 to 800.0	0 to 1400		DIN U	-199.9 to +400.0	-300 to +700
		-200.0 to +400.0	-300 to +700		DIN L	0.0 to 800.0	0 to 1400
	J	0 to 1200	0 to 2000	RTD	JIS Pt100 (IEC)	-199.9 to +500.0	-300 to +700
		0.0 to 800.0	0 to 1400		JIS JPt100	-100.0 to +200.0	-150.0 to +400.0
		-200.0 to +400.0	-300 to +700		JIS JPt100	-199.9 to +500.0	-300 to +700
	E	0.0 to 800.0	0 to 1400	DC current, voltage	4 to 20mA	Scaling setting range -1999 to +9999 (Decimal point position is variable.)	-100.0 to +200.0
	T	-200.0 to +400.0	-300 to +700		0 to 20mA		
	R	0 to 1600	0 to 3000		1 to 5V		
	S	0 to 1600	0 to 3000		0 to 5V		
	B	0 to 1800	0 to 3200		0 to 10mV		
	N	0 to 1300	32 to 2372		0 to 100mV		
	PL II	0 to 1300	32 to 2372		0 to 100mV		
WRe5-26	0 to 2300	0 to 4000	-10 to +10mV				

Model Selection Guide

I II III IV V VI Example: C200DA00001

I	II	III	IV	V	Specifications (○: Included —: Not included)						
Basic model number	Control action	Power supply	Optional function	Option	Event	Current transformer input	Auxiliary output	Communications	Remarks		
C20					Digital controller						
	0D				Time proportional PID: Relay contact 250Vac, 5A resistive load						
	6D				Time proportional PID: Voltage 22.5Vdc±10%						
	5G				Continuous PID: Current 4 to 20mA _{dc} Resistive load: Lower than 600Ω						
		A			100 to 240Vac, 50/60Hz						
		D			21.6 to 26.4Vdc						
						EV1	EV2	CT	AUX	RS-485	RS-232C
					000	—	—	—	—	—	—
					001	○	○	—	—	—	—
					002	○	—	—	—	○	—
				003	○	—	—	—	—	○	
				004	—	—	—	○	○	—	
				005	—	—	—	○	—	○	
				006	○	○	—	○	—	—	
				007	○	○	○	—	—	—	Not applicable to 5G type.
				008	○	—	○	○	—	—	Not applicable to 5G type.
				009	○	—	○	—	○	—	For 6D type only, w/o remote switch input
				010	○	—	○	—	—	○	For 6D type only
				01	Not available.						

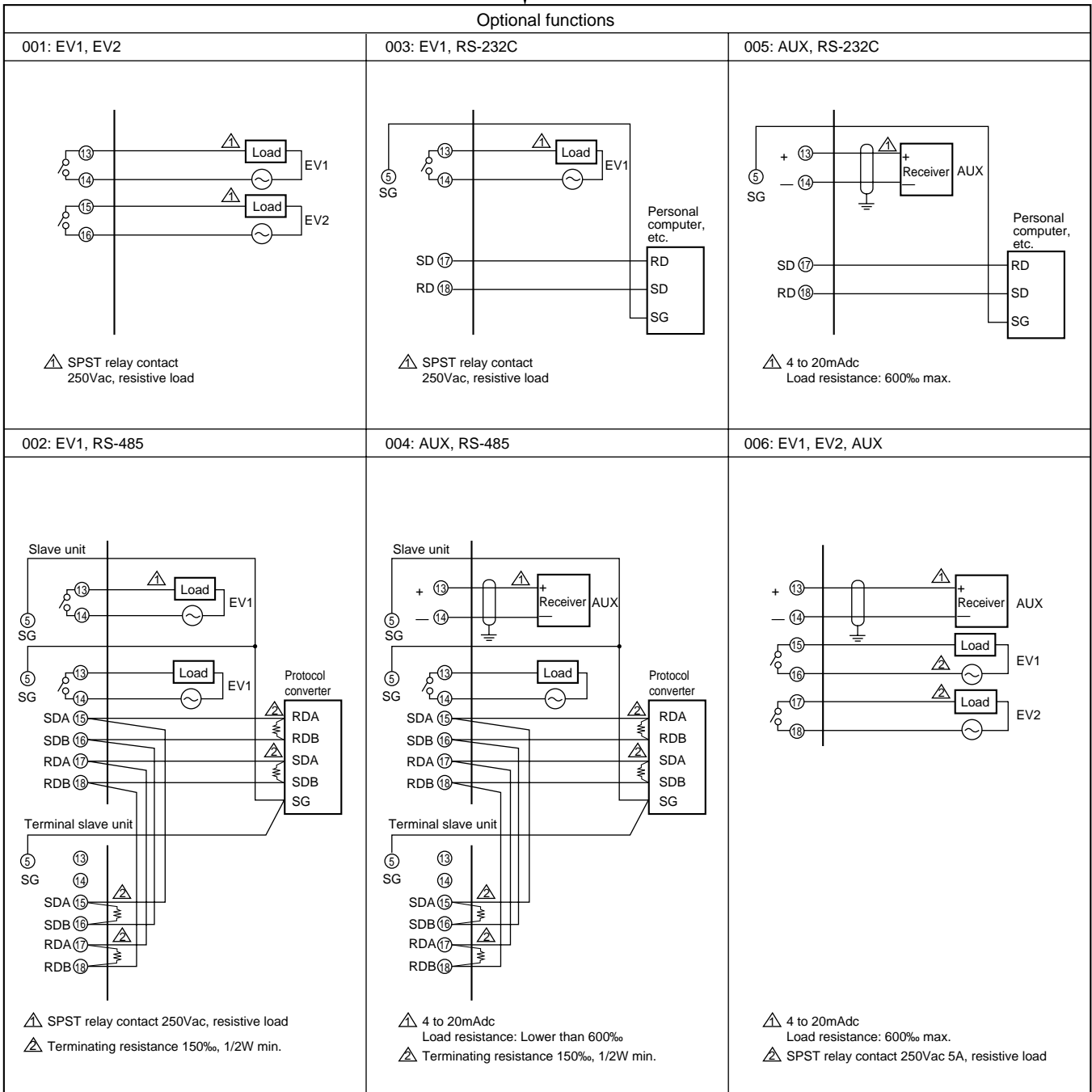
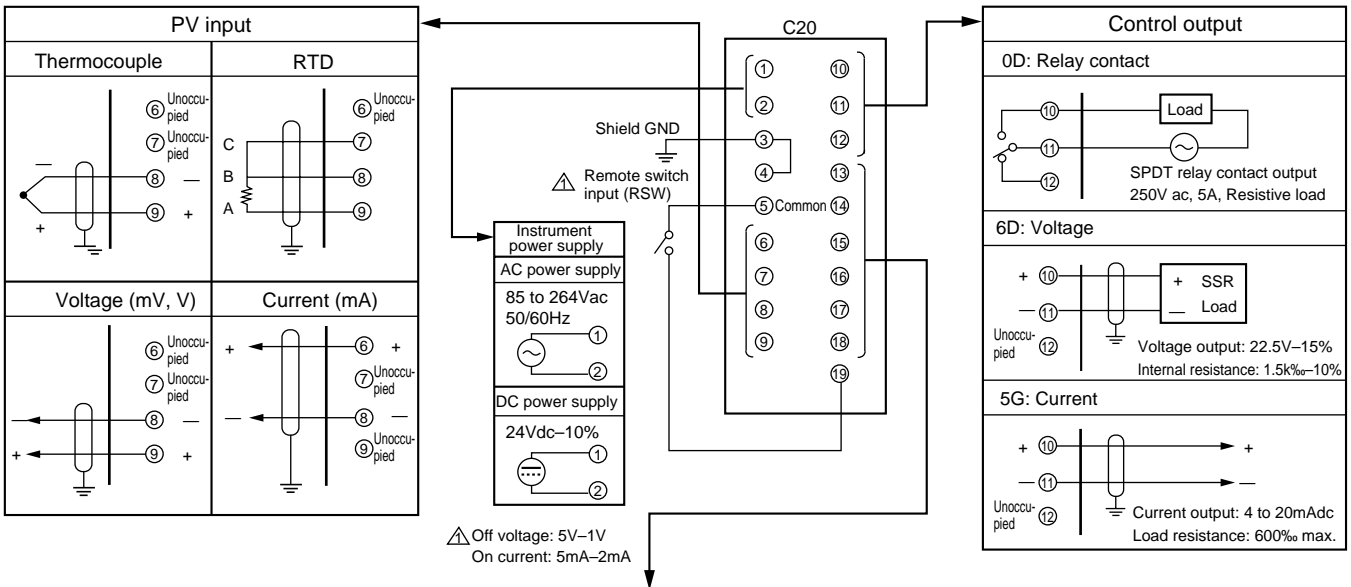

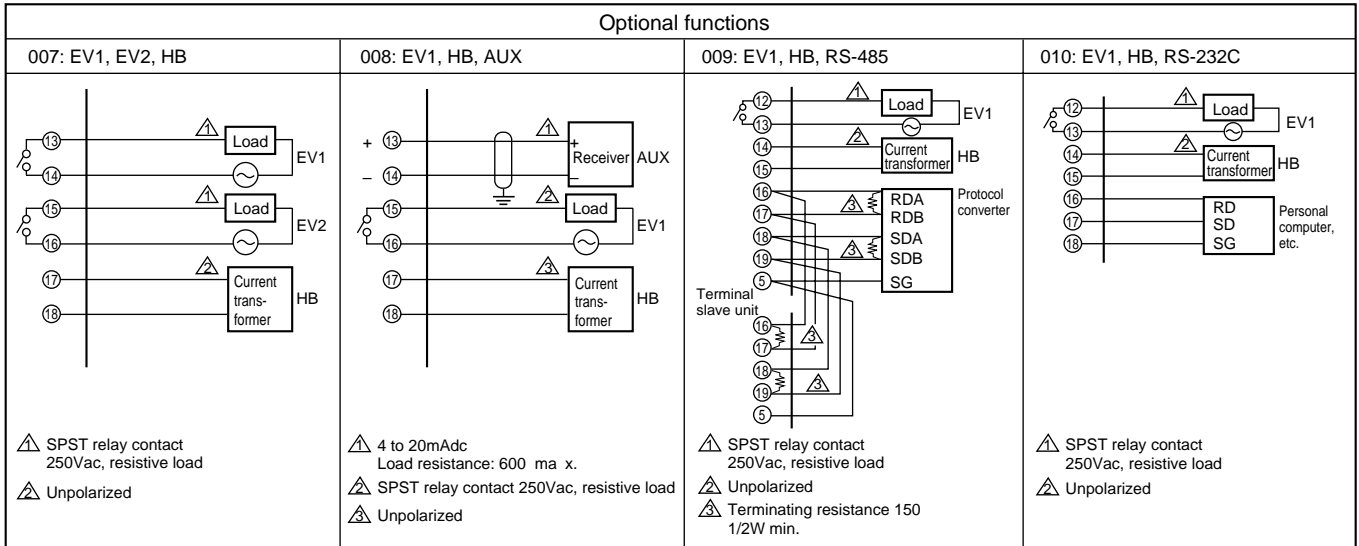

■ Cautions for wiring

1. Isolation

The section bounded by a solid line (——) is isolated from the rest of the circuit.

The section bounded by a dotted line (----) is not isolated from the rest of the circuit.

CT input	Digital circuit	Current output (Control output)
		Current output (Auxiliary output)
		Voltage output (Control output)
PV input		Relay output (Control output)
		Event output 1
	Event output 2	
Remote switch input		Communication I/O

2. Power supply noise

(1) Noise reduction techniques

Always use a noise filter to suppress the influence of noise as much as possible, even if noise is unnoticeable.

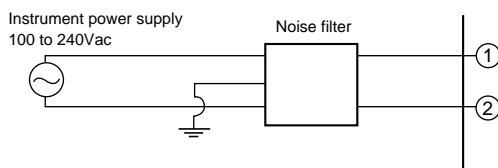

(2) When noise is evident

If noise is observable, suppress it by using an insulation transformer and line filter.

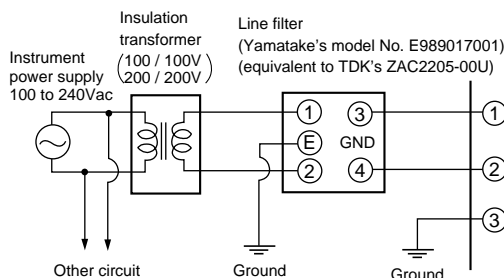

3. Noise

Possible noise sources in the installation environment are: Relays and contacts, electromagnetic coils, solenoid valves, power lines (specifically, those higher than 100Vac), motor commutators, phase angle control SCRs, radio equipment, welding machines, high-voltage ignition devices, etc.

(1) Suppression techniques for quick rising noise

A CR filter is effective for quick rising noise.

Recommended filter: Yamatake's model No. 81446365-001 (equivalent to Matsuo Electric 953M500333311)

(2) Suppression technique, for noise with large peaks:

A varistor is effective for reducing noise with large peaks. However, care should be taken to avoid shorting if varistor is faulty.

Recommended varistor:

Yamatake's model No. 81446366-001 (for 100Vac)

No. 81446367-001 (for 200Vac)

4. Grounding

Ground this controller at a single point to GND terminal ③ to ④. Don't connect any jumper wiring. Prepare a grounding terminal board separately if grounding of a shield wire is difficult.

Grounding type: At least category 3 (100Ω max.)

Grounding wire: Soft copper wire (AWG14) of more than 2mm².

Grounding wire length: 20m max.

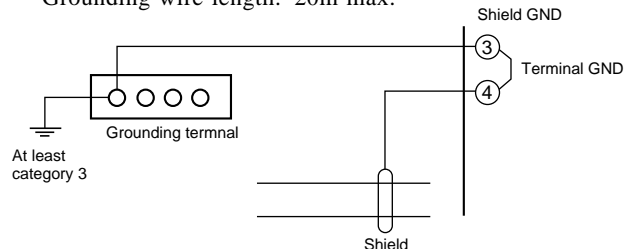

5. Wiring operations

(1) Don't bundle the primary and secondary power lines together, and don't run them in the same wiring conduit or duct after carrying out noise countermeasures.

(2) Run the input/output and communication lines more than 50cm from drive power or power lines of higher than 100Vac. Don't run these wires in the same wiring conduit or duct.

6. Check after wiring

After wiring, be sure to check the connecting line conditions. Be careful: incorrect wiring will cause the instrument to fail.

 **RESTRICTIONS ON USE**

This product has been designed, developed and manufactured for general-purpose application in machinery and equipment. Accordingly, when used in the applications outlined below, special care should be taken to implement a fail-safe and/or redundant design concept as well as a periodic maintenance program.

- **Safety devices for plant worker protection**
- **Start/stop control devices for transportation and material handling machines**
- **Aeronautical/aerospace machines**
- **Control devices for nuclear reactors**

Never use this product in applications where human safety may be put at risk.

Specifications are subject to change without notice.

YAMATAKE

Yamatake Corporation
Advanced Automation Company
International Business Headquarters

Totate International Building
2-12-19 Shibuya Shibuya-ku
Tokyo 150-8316 Japan
URL:<http://www.yamatake.com>

This has been printed on recycled paper.

Printed in Japan. (H)
1st Edition: Issued in May, 1994
4th Edition: Issued in Apr., 2003