

SDC15 Single Loop Controller User's Manual for Installation

Thank you for purchasing the SDC15. Before operating this product described in this User's Manual, please take note of the following points regarding safety. Be sure to keep this manual nearby for handy reference.

RESTRICTIONS ON USE

This product has been designed, developed and manufactured for general-purpose application in machinery and equipment. Accordingly, when used in applications outlined below, special care should be taken to implement a fail-safe and/or redundant design concept as well as a periodic maintenance program.

- Safety devices for plant worker protection
- Start/stop control devices for transportation and material handling machines
- Aeronautical/aerospace machines
- Control devices for nuclear reactors

Never use this product in applications where human safety may be put at risk.

REQUEST

Ensure that this User's Manual is handed over to the user before the product is used. Copying or duplicating this User's Manual in part or in whole is forbidden. The information and specifications in this User's Manual are subject to change without notice. Considerable effort has been made to ensure that this User's Manual is free from inaccuracies and omissions. If you should find any inaccuracies or omissions, please contact Yamatake Corporation. In no event is Yamatake Corporation liable to anyone for any indirect, special or consequential damages as a result of using this product.

©2003 Yamatake Corporation ALL RIGHTS RESERVED

This manual explains handling precautions, mounting, wiring procedures, PV range types, parameter list and main specifications only. See the user's manuals listed below for detailed handling procedures, setting methods, etc. These manuals also contain information on using various functions.

SDC15 Single Loop Controller User's Manual for Basic Operation CP-SP-1147E

SDC15 Single Loop Controller User's Manual for Installation & Configuration CP-SP-1148E

SLP-C35 Smart Loader Package for SDC15/25/26/35/36 Single Loop Controller User's Manual CP-UM-5290E

Unpacking

Check the following items when removing the SDC15 from its package:

Name	Part No.	Q'ty	Remarks
Mounting Bracket	81446403-001	1	For C15T only
Gasket	81409657-001	1	For C15T only
User's Manual	CP-UM-5287E	1	This Manual
	CP-UM-5287	1	

SAFETY PRECAUTIONS



WARNING Warnings are indicated when mishandling this product might result in death or serious injury to the user.



CAUTION Cautions are indicated when mishandling this product might result in minor injury to the user, or only physical damage to this product.

WARNING

- ⚠ Note that incorrect wiring of the SDC15 can damage the SDC15 and lead to other hazards. Check that the SDC15 has been correctly wired before turning the power ON.
- ⚠ Before wiring, or removing/mounting the SDC15, be sure to turn the power OFF. Failure to do so might cause electric shock.
- ⚠ Do not touch electrically charged parts such as the power terminals. Doing so might cause electric shock.
- ⚠ Do not disassemble the SDC15. Doing so might cause electric shock or faulty operation.

CAUTION

- ⚠ Use the SDC15 within the operating ranges recommended in the specifications (temperature, humidity, voltage, vibration, shock, mounting direction, atmosphere, etc.). Failure to do so might cause fire or faulty operation.
- ⚠ Do not block ventilation holes. Doing so might cause fire or faulty operation.
- ⚠ Wire the SDC15 properly according to predetermined standards. Also wire the SDC15 using specified power leads according to recognized installation methods. Failure to do so might cause electric shock, fire or faulty operation.
- ⚠ Do not allow lead clippings, chips or water to enter the controller case. Doing so might cause fire or faulty operation.
- ⚠ Firmly tighten the terminal screws at the torque listed in the specifications. Insufficient tightening of terminal screws might cause electric shock or fire.
- ⚠ Do not use unused terminals on the SDC15 as relay terminals. Doing so might cause electric shock, fire or faulty operation.
- ⚠ We recommend attaching the terminal cover (sold separately) after wiring the SDC15. Failure to do so might cause electric shock, fire or faulty operation.
- ⚠ Use the relays within the recommended service life. Continuous use might cause fire or faulty operation.
- ⚠ Use Yamatake Corporation's "SURGENON" if there is the risk of power surges caused by lightning. Doing so might cause fire or faulty operation.
- ⚠ Do not operate the keys with a propelling pencil or sharp-tipped object. Doing so might cause faulty operation.

Mounting

Location

Install the controller in the following locations:

- Common mode voltages for I/O excluding the power supply and relay contact output: The voltage to ground is 33Vr.m.s max., 46.7V peak max., and 70Vdc max.
- Not high or low temperature / humidity.
- Free from sulfide gas or corrosive gas.
- Less dust or soot.
- Appropriately processed locations to prevent direct sunlight, wind or rain.
- Less mechanical vibration and shock.
- Not close to the high voltage line, welding machine or electrical noise generating source.
- The minimum 15 meters away from the high voltage ignition device for a boiler.
- Less effect by the magnetic.
- No flammable liquid or gas.

Mounting Procedure

- The mounting must be horizontal within 10 degrees tilted in back side lowering or within 10 degrees tilted in back side rising.
- In the case of panel mount type (C15T), the mounting panel should be used with a thickness of less than 9 mm of firm board.

External Dimensions

● C15T (Panel Mount Type)

(unit: mm)

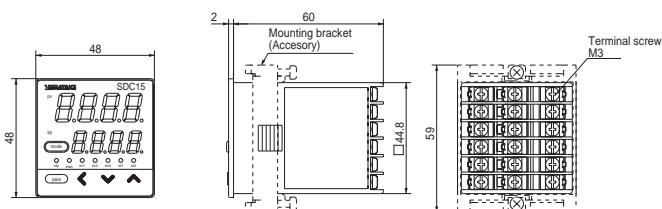

Handling Precautions

To fasten this controller onto the panel, tighten a mounting bracket screws, and turn one more half turn when there is no play between the bracket and panel. Excessively tightening the screws may deform the controller case.

● C15S (Socket Mount Type)

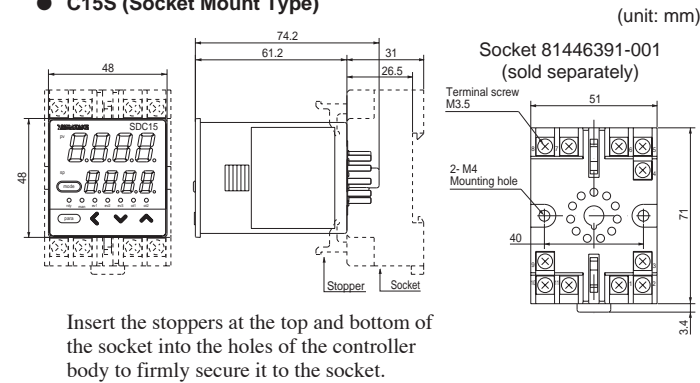

Insert the stoppers at the top and bottom of the socket into the holes of the controller body to firmly secure it to the socket.

● Panel Cutout Dimensions

Stand-alone mounting

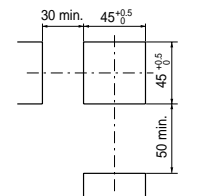

Gang-mounting

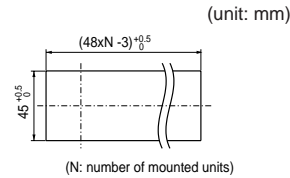

Handling Precautions

- When three or more units are gang-mounted horizontally, the maximum allowable ambient temperature is 40°C.
- If dustproof or waterproof protection is required, mount the device using the stand-alone mounting method. If gang-mounted, dustproof and waterproof protection may not be maintained.
- Provide a space of at least 50mm or more above and below the controller.

Wiring

Be sure to provide a switch within operator reach for shutting OFF the main power supply to the controller in the main supply wiring. Also, in case of AC power supply models, the main supply wiring also requires a time-lagged type (T) fuse (rated current: 0.2A, rated voltage: 250 V). (IEC127)

The following table shows the meaning of the symbols in the terminal wiring label on the controller side:

Symbols	Meaning
—	DC power supply
~	AC power supply
⚠	Caution, fear of electric shock
⚠	Caution

Handling Precautions

- Before wiring the SDC15, verify the controller's model No. and terminal Nos. written on the label on the side of the body. Inspect all wiring once wiring work for the SDC15 has been completed.
- Use M3 crimp-type terminal lugs for wiring to terminal.
- Provide a distance of at least 50cm between I/O lead wires or communications lead wires and power lead wires of 100V min. Also, do not pass these lead wires through the same piping or wiring duct.
- Be careful not to allow any crimp-type terminal lugs to touch adjacent terminals.
- Prepare a heater current conductor to send a heater current through the current transformer. Do not use a heater current that exceeds the specified permissible current as this may damage the controller.
- The controller requires about 6 seconds to start up once the power is turned ON. The controller can be used once it has started up. However, it is recommended to allow a warm-up time of at least 30 minutes to attain the specified accuracy.
- The current transformer input cannot be used for phase control.
- There is no isolation provided between control output 1 and control output 2.
- Do not connect a terminating resistor to either end of the RS-485 communications line. Doing so may interfere with communication.

- Regarding a device or equipment which is connected to this controller, use a model to which the basic insulation meeting with the power supply voltage and the maximum operating voltage of the I/O units is provided.

● Connection of C15T

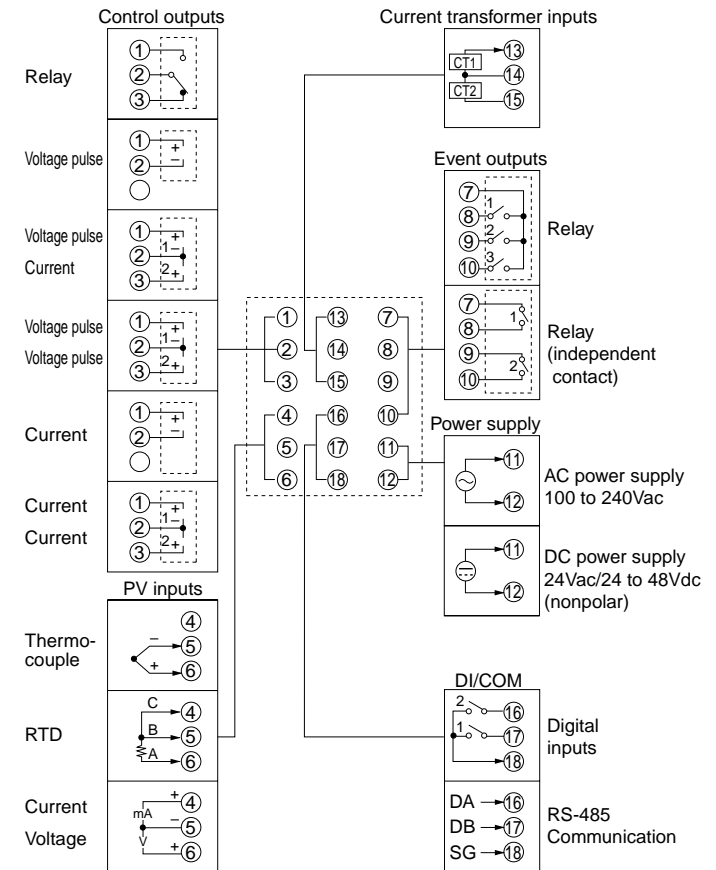

● Connection of C15S

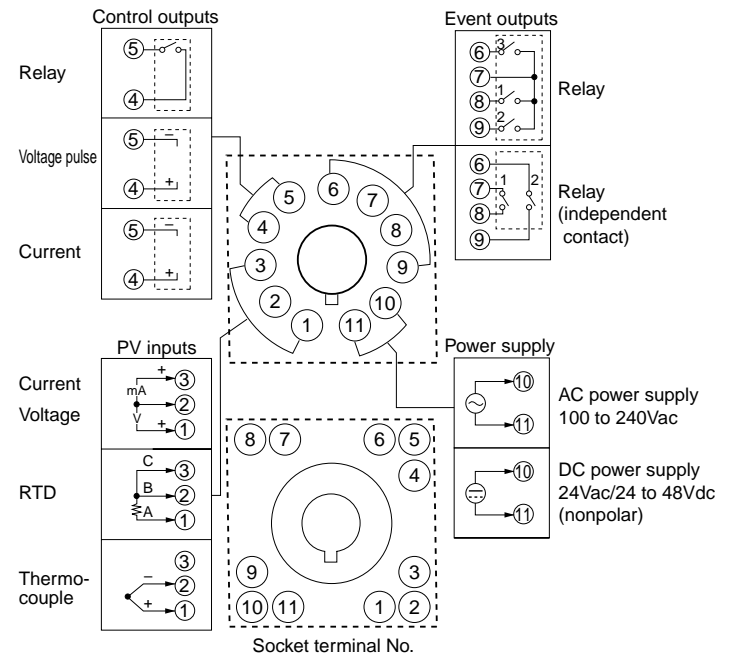

● I/O isolation

Items surrounded by solid lines are insulated from other signals.

Power supply	Internal Circuit	Control output 1
PV input		Control output 2
Current Transformer input 1	Event output 1 (Note)	Event output 2 (Note)
Current Transformer input 2		
Loader communication		
Digital input 1	Event output 3	
Digital input 2		
RS-485 Communication		

Availability of input or output is based on a model number.

(Note) In case of the independent contact, the part between the event output 1 and the event output 2 is isolated.

Part names and functions

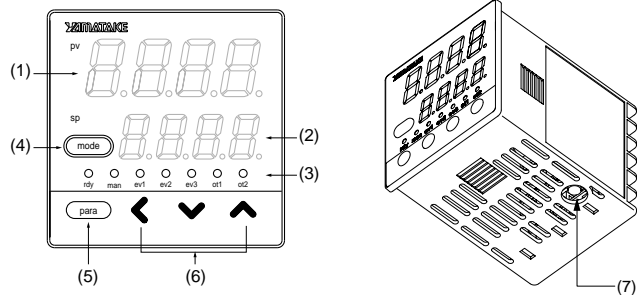

- (1) Upper display : Displays PV values (current temperature, etc.) or setup items.
- (2) Lower display : Displays SP values (set temperature, etc.) and other values of setup items.
- (3) Mode indicator : Lights when READY (control stop) or MANUAL (manual mode).
rdy : Lights when READY (control stop)
man : Lights when MANUAL (manual mode)
ev1 to ev3 : Lights when event relays are ON.
ot1 to ot2 : Lights when the control output is ON.
- (4) Mode key : The operation which was set beforehand can be done by pressing the key for 1s or more. Factory setting is RUN / READY selection.
- (5) Para key : Switches the display.
- (6) <, v, ^ keys : Used for incrementing numeric values and performing arithmetic shift operations.
- (7) Loader connector: Connects to a personal computer with the special cable provided in the smart loader package.

Key Operation and Setting

The following shows the flow of the key operation. Various displays and settings can be called up to the console:

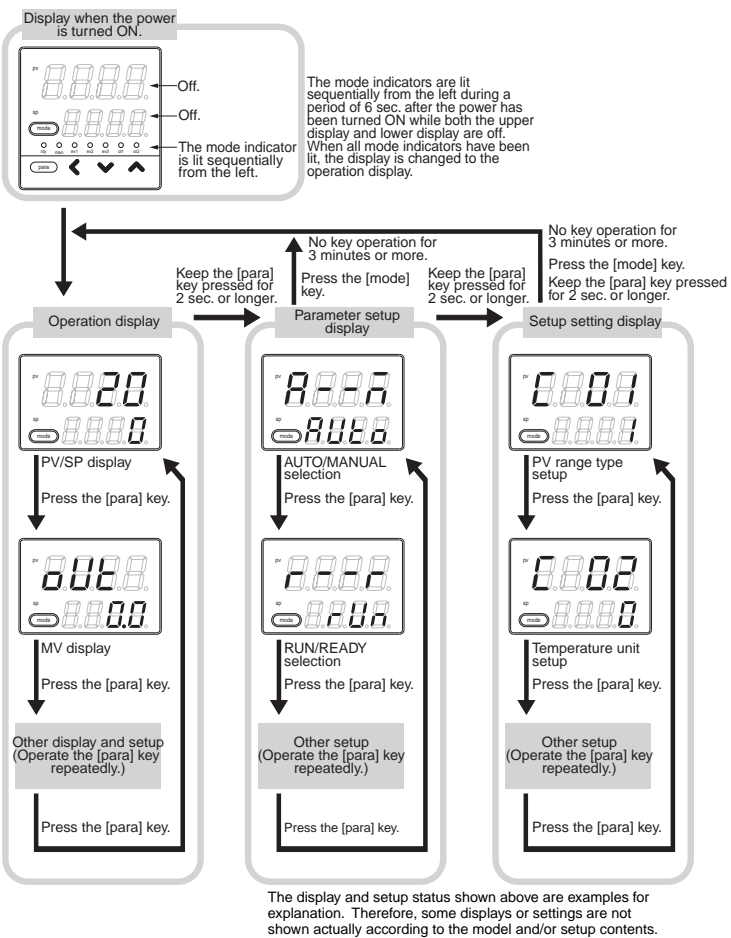

● PV Input range setup

In the setup setting display mode [C01], press the [\leftarrow] • [\vee] • [\wedge] key to set the lower display to select a desired PV range type.
>> When no keys are pressed for 2 sec. or longer, the flashing of the numeric value is stopped to set the currently displayed value.

● SP setup

While the PV/SP is displayed in the operation display mode, press the [\leftarrow] • [\vee] • [\wedge] key to change the SP in the lower display.
>> When no keys are pressed for 2 sec. or longer, the flashing of the numeric value is stopped to set the currently displayed value.
SP can be set in the parameter setting display mode.

For details on handling and setting procedures other than the PV input range setting procedure, refer to the table of parameter list. For the details on operation and setting method, refer to the following user's manuals:
 SDC15 Single Loop Controller User's Manual for Basic Operation CP-SP-1147E
 SDC15 Single Loop Controller User's Manual for Installation & Configuration CP-SP-1148E

PV range table

C01 No.	Sensor type	Range[°C]	Range[°F]	C01 No.	Sensor type	Range[°C]	Range[°F]
1	K	-200 to +1200	-300 to +2200	41	Pt100	-200 to +500	-300 to +900
2	K	0 to 1200	0 to 2200	42	JPt100	-200 to +500	-300 to +900
3	K	0 to 800	0 to 1500	43	Pt100	-200 to +200	-300 to +400
4	K	0 to 600	0 to 1100	44	JPt100	-200 to +200	-300 to +400
5	K	0 to 400	0 to 700	45	Pt100	-100 to +300	-150 to +500
6	K	-200 to +400	-300 to +700	46	JPt100	-100 to +300	-150 to +500
9	J	0 to 800	0 to 1500	51	Pt100	-50.0 to +200.0	-50 to +400
10	J	0 to 600	0 to 1100	52	JPt100	-50.0 to +200.0	-50 to +400
11	J	-200 to +400	-300 to +700	53	Pt100	-50.0 to +100.0	-50 to +200
13	E	0 to 600	0 to 1100	54	JPt100	-50.0 to +100.0	-50 to +200
14	T	-200 to +400	-300 to +700	63	Pt100	0.0 to 200.0	0 to 400
15	R	0 to 1600	0 to 3000	64	JPt100	0.0 to 200.0	0 to 400
16	S	0 to 1600	0 to 3000	67	Pt100	0 to 500	0 to 900
17	B	0 to 1800	0 to 3300	68	JPt100	0 to 500	0 to 900
18	N	0 to 1300	0 to 2300				
19	PLII	0 to 1300	0 to 2300				
20	WRe5-26	0 to 1400	0 to 2400				
21	WRe5-26	0 to 2300	0 to 4200				
24	DIN U	-200 to +400	-300 to +700				
25	DIN L	-100 to +800	-150 to +1500				

C01 No.	Sensor type	Range
84	0 to 1V	The scaling and decimal point position can be changed variably in a range of -1999 to +9999
86	1 to 5V	
87	0 to 5V	
88	0 to 10V	
89	0 to 20mA	
90	4 to 20mA	

! Handling Precautions

- The accuracy of the B thermocouple is $\pm 5\%$ FS for a range of 260°C or less, and $\pm 1\%$ FS for 260 to 800°C. The indicated low limit is 20°C.
- The accuracy of the PLII thermocouple(C01 No.19) in the range of 0 to 32°F does not meet the indication accuracy specified in the Specifications.
- For ranges with a decimal point, tenths are displayed on the line underneath point.
- Set by the number of setup C01 according to the type and range of the sensor used.

Alarm code table

This table shows a list of malfunction alarms and countermeasures to take in each case.

Alarm code	Error	Cause	Countermeasure
AL01	PV input error (over range)	Sensor line break, incorrect wiring, incorrect range code setting	Checking wiring or reset range code..
AL02	PV input error (under range)	Sensor line break, incorrect wiring, incorrect range code setting	
AL03	CJ failure	Terminal temperature compensation unit failure (thermocouple)	Checking the allowable ambient temperature.
	PV input error	Sensor line break, incorrect wiring (RTD)	Checking wiring.
AL11	CT input failure (over-range) (CT input 1 or 2, or both)	A current exceeding the upper limit of the display range was measured. The number of CT turns or the number of CT power wire loops is incorrectly set, or wiring is incorrect.	<ul style="list-style-type: none"> Use a CT with the correct number of turns for the display range. Reset the number of CT turns. Reset the number of CT power wire loops. Check the wiring.
AL70	A/D conversion error	Defective A/D converter	Replace unit.
AL95	Parameter error	<ul style="list-style-type: none"> Power turned OFF during fixing of data Data corrupted due to noise, etc. 	Reset data or replace unit.
AL96	Adjustment data error	<ul style="list-style-type: none"> Power turned OFF during fixing of data Data corrupted due to noise, etc. 	
AL97	Parameter error (RAM area)	Data corrupted due to noise, etc.	
AL98	Adjustment data error (RAM area)	Data corrupted due to noise, etc.	
AL99	ROM error	Data corrupted due to noise, etc.	Replace unit.

Maintenance

- Cleaning:** When wiping out the SDC15, use the soft and dried cloth.
- Parts replacement:** Do not replace the parts.
- Fuse replacement:** When replacing the fuse for the power supply wires, make sure that the replacement fuse complies with all applicable safety standards.
Standard IEC127, Cutoff Speed Delayed operation type (T), Rated Voltage 250V, Rated Current 200mA

Model selection table

Basic model No.	Mounting	Control output	PV input	Power supply	Optional functions	Additional processing	Specifications
C15							
(Note 4)	T						Panel mount type
	S						Socket mount type
(Note 2)		R0					Control output 1
		V0					Control output 2
(Note 1)		VC					Relay contact output
							None
(Note 1)		VV					Voltage pulse output (for SSR drive)
							Current output
(Note 1)							Voltage pulse output (for SSR drive)
							Voltage pulse output (for SSR drive)
(Note 1)		CC					Current output
							Current output
							Thermocouple input (K, J, E, T, R, S, B, N, PLII, WRe5-26, DINU, DINL)
							RTD input (Pt100/JPt100)
							DC voltage /DC current input (0 to 1Vdc, 1 to 5Vdc, 0 to 5Vdc, 0 to 10Vdc, 0 to 20mAdc, 4 to 20mAdc)
							AC Model (100 to 240Vac)
							DC Model (24Vac, 24 to 48Vdc)
							00 None
							01 Event relay output: 3 points
(Note 1, 3)							02 Event relay output: 3 points Current transformer input: 2 points Digital input: 2 points
(Note 1, 3)							03 Event relay output: 3 points Current transformer input: 2 points RS-485 communication
(Note 5)							04 Event relay output: 2 points (independent contact)
(Note 1, 3, 5)							05 Event relay output: 2 points (independent contact) Current transformer input: 2 points (independent contact) Digital input: 2 points
(Note 1, 3, 5)							06 Event relay output: 2 points (independent contact) Current transformer input: 2 points RS-485 communication
							00 No additional processing
							D0 Inspection Certificate provided
							Y0 Complying with the traceability certification

- Note 1. Can not be selected for the C15S.
- Note 2. Only 1a contact applicable for the C15S
- Note 3. Current transformer sold separately
- Note 4. Socket sold separately
- Note 5. Can not be selected for the DC model.

Specifications

- PV Input**
 - Thermocouple: K,J,E,T,R,S,B,N (JIS C1602-1995)
PL II (Engelhard Industries Data (ITS90))
WRe5-26 (ASTM E988-96(Reapproved 2002))
DIN U,DIN L (DIN 43710-1985)
 - Resistance temperature detector (RTD): Pt100 (JIS C1604-1997)
JPt100 (JIS C1604-1989)
0 to 1V, 1 to 5V, 0 to 5V, 0 to 10V
0 to 20mA, 4 to 20mA
 - DC voltage: 0 to 1V, 1 to 5V, 0 to 5V, 0 to 10V
 - DC current: 0 to 20mA, 4 to 20mA
 - Sampling cycle: 500ms
 - Accuracy: $\pm 0.5\%$ FS ± 1 digit,
 $\pm 1\%$ FS ± 1 digit for a negative area of the thermocouple (at ambient temperature 23 $\pm 2^\circ$ C)
- Digital input**
 - Input type: Dry contact or open collector
 - Allowable ON contact resistance: Max.250 Ω
 - Allowable OFF contact resistance: Min.100k Ω
 - Allowable ON voltage: Max.1.0V
 - Terminal current (ON): Approx.7.5mA in case of short circuit
Approx.5.0mA in case of contact resistance 250 Ω
 - Minimum hold time: 1s or more
- Current transformer input**
 - Number of input points: 2 points
 - Input object: Current transformer with 100 to 4,000 turns (availability is by 100-turn units)
Optional unit Model No.: QN206A (800 turns, hole diameter: 5.8 mm)
Optional unit Model No.: QN212A (800 turns, hole diameter: 12mm)
- Current measurement lower limit:** 0.4Aac (800 turns, 1 time)
Formula; Number of turns \div (2000 x number of power wire loops)
- Current measurement upper limit:** 50.0Aac (800 turns, 1 time)

- Allowable measured current:** 70.0Aac (800 turns, 1 time)
Formula; Number of turns \div (16 x number of power wire loops) x 1.4
- Display range lower limit:** 0.0Aac
- Display range upper limit:** 70.0Aac (800 turns, 1 time)
Formula; Number of turns \div (16 x number of power wire loops) x 1.4
- Display accuracy:** $\pm 5\%$ FS
- Display resolution:** 0.1Aac
- Control Output**
 - Relay output
 - Contact rating: NO side 250Vac/30Vdc, 3A (resistive load)
NC side 250Vac/30Vdc, 1A (resistive load)
 - Life: NO side Min. 50,000 operations
NC side Min. 100,000 operations
 - Min. switching specifications: 5V, 100mA
 - Min. ON time / OFF time: ≥ 25 ms
- Voltage pulse output (for SSR drive)**
 - Open circuit voltage: 19Vdc $\pm 15\%$
 - Internal resistance: Max. 24mAdc
 - Allowable current: Max. 24mAdc
 - Min. OFF time / ON time: 1ms (Time proportional cycle time < 10s)
250ms (Time proportional cycle time ≥ 10 s)
- Current output**
 - Output type: 0 to 20mAdc or 4 to 20mAdc current output
 - Allowable load resistance: Max.600 Ω
 - Output accuracy: $\pm 0.5\%$ FS (at ambient temperature 23 $\pm 2^\circ$ C)
 $\pm 1\%$ FS at 0 to 1mA
- Event relay outputs (ev1 to 3)**
 - Contact rating: 250Vac/30Vdc 2A (resistive load)
 - Life: Min. 100,000 operations
 - Min. switching specification: 5V, 10mA (Reference value)
- RS-485 communication**
 - Transmission line: 3-wire system
 - Transmission speed: 4800, 9600, 19200, 38400bps
 - Communication protocol: CPL and MODBUS conforming
 - Terminating resistor: Do not connect a terminating resistor.
- Environmental condition**
 - Operating conditions**
 - Ambient temperature: 0 to 50°C (Gang-mounting: 0 to 40°C)
 - Ambient humidity: 10 to 90%RH (non-condensing)
 - Power supply voltage: AC Model
85 to 264Vac, 50/60Hz ± 2 Hz
(Rated power voltage 100 to 240Vac 50/60Hz)
DC Model
21.6 to 26.4Vac, 50/60Hz ± 2 Hz
21.6 to 52.8Vdc
(Rated power voltage 24Vac 50/60Hz, 24 to 48 Vdc)
 - Transport conditions**
 - Ambient temperature: -20 to +70°C
 - Ambient humidity: 10 to 95%RH (non-condensing)
- Other specifications**
 - Degrees of protection: Case front side IP66 /NEMA 4X equivalent (Only for stand-alone mounting on a panel when an attached gasket is used.)
 - Power consumption: AC Model
Max. 12VA (100Vac:8VA, 264Vac:12VA)
(6VA for 100Vac and 9VA for 264Vac to our company SDC10 equivalent function)
DC Model
Max. 7VA (24Vac)
Max. 5W (24 to 48Vdc)
 - Non-detected power failure time: Max. 20ms (AC model)
No power failure allowed (DC model)
 - Altitude: Max. 2000m
 - Mass: Approx.150g (with mounting bracket) at panel mount type
Approx.200g (with socket) at socket mount type
 - Terminal screw tightening torque: 0.4 to 0.6N·m
 - Applicable standards: EN61010-1, EN61326
 - Over-voltage category: Category II (IEC60364-4-443, IEC60664-1)
 - Allowable pollution degree: Pollution degree 2

Accessories and optional parts

Name	Model No.
Mounting bracket (for C15T)	81446403-001 (Accessory)
Gasket	81409657-001 (Accessory)
Current transformer	QN206A (5.8mm hole dia.) QN212A (12mm hole dia.)
Socket (for C15S)	81446391-001
Hard cover	81446442-001
Soft cover	81446443-001
Terminal cover	81446898-001

SDC15 List of Parameters

[List of Operation Displays]

■ Operation Displays

Display	Item	Contents	Initial value	User level
Upper display: PV Lower display: SP	SP (Target value)	SP low limit (C07) to SP high limit (C08)	0	0
LSP Lower display: LSP	LSP No. (1st digit: Value at the right end digit)	1 to LSP system group (C30 Max. 4) (Numeric value does not flash.) Setting is enabled in MANUAL mode. (Numeric value flashes.)	1	0
oL	MV (Manipulated Variable)	-10.0 to +110.0% Setting is disabled in AUTO mode. (Numeric value does not flash.) Setting is enabled in MANUAL mode. (Numeric value flashes.)	-	0
HE	Heat MV (Manipulated Variable)	Setting is disabled -10.0 to +110.0%	-	0
oL	Cool MV (Manipulated Variable)	Setting is disabled -10.0 to +110.0%	-	0
Upper display: PV R (display example)	AT progress display (1st digit = Numeric value at right end digit)	Setting is disabled. Except for 0: During execution of AT (Value is decreased.) 0: Completion of AT	-	0
CT	CT (Current transformer) current value 1	Setting is disabled.	-	0
CT	CT (Current transformer) current value 2	Setting is disabled.	-	0
E	Internal event 1 main setting	Setting range is different depending on the internal event operation type. -1999 to +9999U: Except below. 0 to 9999U: When the setting value is an absolute value. -199.9 to +999.9%: For MV.	0	0
E 1.5b	Internal event 1 sub-setting	Setting is disabled.	-	0
E 1. . .	Timer remaining time 1	Setting is disabled. Upper display: The distinction by ON delay or OFF delay is displayed at the side location of [1.]. Lower display: Displayed by the unit (either one of 0.1s, s, or min) based on the internal event 1 delay time unit (E1, the 3rd digit of C3).	-	0
E2	Internal event 2 main setting	Setting range is different depending on the internal event operation type. -1999 to +9999U: Except below. 0 to 9999U: When the setting value is an absolute value. -199.9 to +999.9%: For MV.	0	0
E2.5b	Internal event 2 sub-setting	Setting is disabled.	-	0
E2. . .	Timer remaining time 2	Setting is disabled. Upper display: The distinction by ON delay or OFF delay is displayed at the side location of [2.]. Lower display: Displayed by the unit (either one of 0.1s, s, or min) based on the internal event 2 delay time unit (E2, the 3rd digit of C3).	-	0
E3	Internal event 3 main setting	Setting range is different depending on the internal event operation type. -1999 to +9999U: Except below. 0 to 9999U: When the setting value is an absolute value. -199.9 to +999.9%: For MV.	0	0
E3.5b	Internal event 3 sub-setting	Setting is disabled.	-	0
E3. . .	Timer remaining time 3	Setting is disabled. Upper display: The distinction by ON delay or OFF delay is displayed at the side location of [3.]. Lower display: Displayed by the unit (either one of 0.1s, s, or min) based on the internal event 3 delay time unit (E3, the 3rd digit of C3).	-	0

[List of Parameter Setting Displays]

■ Mode bank

Bank selection: *no*

Display	Item	Contents	Initial value	User level
R- <i>n</i>	AUTO/MANUAL mode selection	R <i>o</i> : AUTO mode R <i>n</i> : MANUAL mode	AUTO	0
r- <i>r</i>	RUN/READY mode selection	R <i>o</i> : RUN mode R <i>r</i> : READY mode	RUN	0
R	AT Stop/Start selection	R <i>o</i> : AT Stop R <i>s</i> : AT Start	AT Stop	0
oL	Release all DO latches	L <i>e</i> : Latch continue L <i>r</i> : Latch release	Latch continue	0
CT	Communication DI 1	C <i>o</i> : OFF C <i>o</i> : ON	OFF	0

■ SP bank

Bank selection: *SP*

Display	Item	Contents	Initial value	User level
SP-1 to SP-4	SP of LSP1 group to LSP4 group	SP low limit (C07) to SP high limit (C08)	0	0

■ Event bank

Bank selection: *E*

Display	Item	Contents	Initial value	User level
E1 to E5	Internal event 1 to 5, main setting	-1999 to +9999 The decimal point position varies by meeting the internal event operation type.	0	0
E1.5b to E5.5b	Internal event 1 to 5, sub-setting	0 to 9999 for some operation type.	0	0
E1.HY to E5.HY	Internal event 1 to 5, hysteresis	0 to 9999 The decimal point position varies by meeting the internal event operation type.	5	0
E1.ON to E5.ON	Internal event 1 to 5, ON delay	0.0 to 999.9 (For the delay time unit 0.1s)	0	2
E1.OFF to E5.OFF	Internal event 1 to 5, OFF delay	0 to 9999 (Except for the delay time unit 0.1s)	0	2

User level details 0: Display in basic / standard / high function,
1: Display in standard / high function,
2: Display in high function.

Initial value may vary depending on model No.

■ PID bank

Bank selection: *PID*

Display	Item	Contents	Initial value	User level
P-1	Proportional band	0.1 to 999.9%	5.0	0
I-1	Integration time	0 to 9999s (0: No integral control action)	120	0
D-1	Derivative time	0 to 9999s (0: No derivative control action)	30	0
rE-1	Manual reset	-10.0 to +110.0%	50.0	0
oL-1	MV low limit	-10.0 to +110.0%	0.0	1
oH-1	MV high limit	-10.0 to +110.0%	100.0	1
P-1C	Cool-side proportional band	0.1 to 999.9%	5.0	0
I-1C	Cool-side integration time	0 to 9999s (0: No integral control action)	120	0
D-1C	Cool-side derivative time	0 to 9999s (0: No derivative control action)	30	0
oL-1C	Cool-side MV low limit	-10.0 to +110.0%	0.0	1
oH-1C	Cool-side MV high limit	-10.0 to +110.0%	100.0	1

■ Parameter bank

Bank selection: *PRR*

Display	Item	Contents	Initial value	User level
CB-1	Control method	0: ON/OFF control 1: PID fixed 2: ST (Self turning)	0 or 1	0
RL	MV low limit at AT	-10.0 to +110.0%	0.0	0
RH	MV high limit at AT	-10.0 to +110.0%	100.0	0
dFF	ON/OFF control differential	0 to 9999U	5	0
oFF5	ON/OFF control operating point differential	-1999 to 9999U	0	2
FL	PV filter	0.0 to 120.0s	0.0	0
rR	PV ratio	0.001 to 9.999	1.000	1
b	PV bias	-1999 to +9999U	0	0
LYU	Time proportional cycle unit 1	0: 1s unit 1: 0.5s fixed (Cycle time is disabled.) 2: 0.2s fixed (Cycle time is disabled.) 3: 0.1s fixed (Cycle time is disabled.)	0	2
LY	Time proportional cycle 1	5 to 120s (The output includes the relay output.) 1 to 120s (The output does not include the relay output.)	10 or 2	0
LYU2	Time proportional cycle unit 2	0: 1s unit 1: 0.5s fixed (Cycle time is disabled.) 2: 0.2s fixed (Cycle time is disabled.) 3: 0.1s fixed (Cycle time is disabled.)	0	2
LY2	Time proportional cycle 2	5 to 120s (The output includes the relay output.) 1 to 120s (The output does not include the relay output.)	10 or 2	0
EP, EY	Time proportional operation type	0: Controllability aiming type 1: Actuator life aiming type (Only one ON/OFF operation within time proportional cycle time)	0 or 1	2
SPU	SP ramp-up	0.0 to 999.9U (0.0: No ramp)	0.0	2
SPD	SP ramp-down	0.0 to 999.9U (0.0: No ramp)	0.0	2

■ Extension tuning bank

Bank selection: *E*

Display	Item	Contents	Initial value	User level
RL, EY	AT type	0: Normal (Standard control characteristics) 1: Immediate response (Control characteristics immediately responding to the external disturbance.) 2: Stable (Control characteristics with less up/down function of PV)	1	0
JF, bD	Just-FITTER setting band	0.00 to 10.00	0.30	2
SP, L3	SP lag constant	0.0 to 999.9	0.0	2
RL-P	Proportional band tuning factor at AT	0.00 to 99.99	1.00	2
RL-1	Integration time tuning factor at AT	0.00 to 99.99	1.00	2
RL-d	Derivative time tuning factor at AT	0.00 to 99.99	1.00	2
CT, R	Control algorithm	0: PID (conventional PID) 1: Ra-PID (high performance type)	0	1
JF, ov	Just-FITTER overshoot suppression factor	0 to 100	0	1
SE, SR	ST step execution resolution width	0.00 to 99.99%	10.00	2
SE, Sb	ST step settling bound	0.00 to 10.00%	0.50	2
SE, Hb	ST hunting settling bound	0.00 to 10.00%	1.00	2
SE, Ud	ST step ramp change	0: ST is executed when the PV ramp up or down. 1: ST is executed only when the PV ramp up.	0	1

[List of Setup Setting Displays]

■ Setup bank

Bank selection: *SEU*

Display	Item	Contents	Initial value	User level
CT 1	PV input range type	Thermocouple (T): 1 to 6, 9 to 11, 13 to 21, 24, 25 RTD (R): 41 to 46, 51 to 54, 63, 64, 67, 68 DC current/voltage (L): 84, 86 to 90	1 41 88	0
CT 2	Temperature unit	0: Centigrade (°C) 1: Fahrenheit (°F)	0	0
CT 3	Cold junction compensation	0: Cold junction compensation is performed. (Internal) 1: Cold junction compensation is not performed. (External)	0	2
CT 4	Decimal point position	0: No decimal point 1: One digit below decimal point 2: Two digits below decimal point 3: Three digits below decimal point (Select '0' or '1' for the RTD range with decimal point)	0	0
CT 5	PV range low limit	When the PV input range type is thermocouple (T) or RTD (R), the setting is disabled although range low limit is displayed. -1999 to +9999U when the PV input range type is DC voltage/current (L).	-	0
CT 6	PV range high	When the PV input range type is thermocouple (T) or RTD (R), the setting is disabled although range high limit is displayed. -1999 to +9999U when the PV input range type is DC voltage/current (L).	-	0
CT 7	SP low limit	PV input range low limit to PV input range high limit	0	1
CT 8	SP high limit		1000	1
CT 9	Squarer root extraction dropout	0.0 to 100.0% (0.0: No square root extraction)	0.0	2
CT 14	Control action (direct/reverse)	0: Heat control (reverse action) 1: Cool control (direct action)	0	0
CT 15	Selection of MV at PV alarm occurrence	0: Control operation is continued. 1: MV at PV alarm occurrence is outputted.	0	2
CT 16	MV at PV alarm occurrence	-10.0 to +110.0%	0.0	2
CT 17	MV at READY (at heat-side for heat/cool control)	-10.0 to +110.0%	0.0	1
CT 18	MV at READY (at cool-side)	-10.0 to +110.0%	0.0	1
CT 19	Operation at MANUAL change	0: Bump-less 1: Preset	0	1
CT 20	Preset MANUAL value	-10.0 to +110.0% (Used even at MANUAL mode when power is ON.)	0.0 or 50.0	1
CT 21	PID operation initialization function selection	0: Automatic 1: Not initialized 2: Initialized (when SP value different from current value is inputted.)	0	2
CT 22	PID operation initial MV	-10.0 to +110.0%	0.0 or 50.0	2
CT 26	Heat/cool control	0: Disabled. 1: Enabled.	0	0
CT 27	Heat/cool selection	0: Normal 1: Energy saving	0	1
CT 28	Dead zone	-100.0 to +100.0%	0.0	0
CT 29	Heat/cool control selection point	-10.0 to +110.0%	50.0	2
CT 30	LSP setting system	1 to 4	1	0
CT 32	SP ramp unit	0: 0.1U/s 1: 0.1U/min 2: 0.1U/h	0	2
CT 36	CT1 operation type	0: Heater burnout detection 1: Current value measurement	0	0
CT 37	CT1 output	0: Control output 1 1: Control output 2 2: Event output 1 3: Event output 2 4: Event output 3	0	0
CT 38	CT1 measurement wait time	30 to 300ms	30	0
CT 39	CT2 operation type	Same as CT1.	0	0
CT 40	CT2 output		0	0
CT 41	CT2 measurement wait time		30	0
CT 42	Control output 1 range	1: 4 to 2mA 2: 0 to 20mA	1	0
CT 43	Control output 1 type	0: MV 1: Heat MV 2: Cool MV 3: PV 4: PV before ratio bias filter 5: SP 6: Deviation 7: CT1 current value 8: CT2 current value 9: Invalid 10: SP+MV 11: PV+MV	0	0
CT 44	Control output 1 scaling low limit	-1999 to +9999 (The decimal point position and unit may vary depending on the control output 1 type.)	0.0	0
CT 45	Control output 1 scaling high limit		100.0	0
CT 46	Control output 1 MV scaling	0 to 9999 The decimal point position and unit are same as for PV.	200.0	0
CT 47	Control output 2 range	Same as control output 1.	1	0
CT 48	Control output 2 type		3	0
CT 49	Control output 2 scaling low limit	-1999 to +9999 (The decimal point position and unit may vary depending on the control output 2 type.)	0	0
CT 50	Control output 2 scaling high limit		1000	0
CT 51	Control output 2 MV scaling	0 to 9999 The decimal point position and unit are same as for PV.	200.0	0

Display	Item	Contents	Initial value	User level
CT 64	CPL/MODBUS	0: CPL 1: MODBUS ASCII format 2: MODBUS RTU format	0	0
CT 65	Station address	0 to 127 Communication is disabled when "0" is set.	0	0
CT 66	Transmission speed	0: 4800bps 1: 9600bps 2: 19200bps 3: 38400bps	2	0
CT 67	Data format (data length)	0: 7bits 1: 8bits	1	0
CT 68	Data format (parity)	0: Even parity 1: Odd parity 2: No parity	0	0
CT 69	Data format (stop bits)	0: 1bit 1: 2bits	0	0
CT 70	Communication minimum response time	1 to 250ms	3	2
CT 71	Key operation mode/type	0: Standard type 1: Special type	0	2
CT 72	MODE key function	0: Invalid 1: AUTO/MANUAL selection 2: RUN/READY selection 3: AT Stop/Start 4: LSP group selection 5: Release of all DO latches 6: Invalid 7: Communication DI1 selection 8: Invalid	1	0
CT 73	MODE display setup	Whether the mode bank setup display is enabled or disabled is determined by the sum of the following weighting: Bit 0: AUTO/MANUAL display 0: Disabled, +1: Enabled Bit 1: RUN/READY display 0: Disabled, +2: Enabled Bit 3: AT stop/start display 0: Disabled, +8: Enabled Bit 4: DO latch release 0: Disabled, +16: Enabled Bit 5: Communication DI1 ON/OFF display 0: Disabled, +32: Enabled Other invalid setup: 0, +4, +64, +128	255	1
CT 74	PV/SP value display setup	Whether the basic display is enabled or disabled is determined by the sum of the following weighting: Bit 0: PV display 0: Disabled, +1: Enabled Bit 1: SP display 0: Disabled, +2: Enabled Bit 2: LSP group No. display 0: Disabled, +4: Enabled Other invalid setup: 0, +8	15	1
CT 75	MV display setup	Whether the basic display is enabled or disabled is determined by the sum of the following weighting: Bit 0: MV display 0: Disabled, +1: Enabled Bit 1: Heat MV/cool MV display 0: Disabled, +2: Enabled Bit 3: AT progress display 0: Disabled, +8: Enabled Other invalid setup: 0, +4	15	1
CT 76	Event setting value display setup	0: In the operation display mode, the internal event setting value is not displayed. 1: In the operation display mode, the internal event 1 setting value is displayed. 2: In the operation display mode, the internal event 1 to 2 setting value is displayed. 3: In the operation display mode, the internal event 1 to 3 setting value is displayed.	0	1
CT 77	Event remaining time display setup	0: In the operation display mode, the ON/OFF delay remaining time of the internal event is not displayed. 1: In the operation display mode, the ON/OFF delay remaining time of the internal event 1 is displayed. 2: In the operation display mode, the ON/OFF delay remaining time of the internal event 1 to 2 is displayed. 3: In the operation display mode, the ON/OFF delay remaining time of the internal event 1 to 3 is displayed.	0	1
CT 78	CT input current value display setup	0: In the operation display mode, the CT current value is not displayed. 1: In the operation display mode, the CT1 current value is displayed. 2: In the operation display mode, the CT1 to 2 current value is displayed.	0	1
CT 79	User level	0: Basic configuration 1: Standard configuration 2: High function configuration	0	0
CT 80	LED monitor	0: Disabled 1: Flashing at RS-485 communication signal transmission 2: Flashing at RS-485 communication signal receiving 3: OR (logical sum) of all DI status 4: Flashing at READY	0	2
CT 90	Number of CT1 turns	0: 800 turns 1 to 40: CT turns divided by 100.	8	2
CT 91	Number of CT1 power wire loops	0: 1 time 1 to 6: Number of times	1	2
CT 92	Number of CT2 turns	0: 800 turns 1 to 40: CT turns divided by 100.	8	2
CT 93	Number of CT2 power wire loops	0: 1 time 1 to 6: Number of times	1	2

(continued on back page)

■ Event assignment bank

Bank selection: $EUCF$

Display	Item	Contents	Initial value	User level
$E1.C1$ to $E5.C1$	Operation type of internal event 1 to 5 configuration 1	0: No event 1: PV high limit 2: PV low limit 3: PV high/low limit 4: Deviation high limit 5: Deviation low limit 6: Deviation high/low limit 7: Deviation high limit (Final SP reference) 8: Deviation low limit (Final SP reference) 9: Deviation high/low limit (Final SP reference) 10: SP high limit 11: SP low limit 12: SP high/low limit 13: MV high limit 14: MV low limit 15: MV high/low limit 16: CT1 heater burnout/over-current 17: CT1 heater short-circuit 18: CT2 heater burnout/over-current 19: CT2 heater short-circuit 20: Loop diagnosis 1 21: Loop diagnosis 2 22: Loop diagnosis 3 23: Alarm (status) 24: READY (status) 25: MANUAL (status) 26: Invalid 27: During AT execution (status) 28: During SP ramp (status) 29: Control direct action (status) 30: ST execution (status) 31: Invalid 32: Timer (status) 33: High and low limits of MFB value (Invalid in this unit)	0	0
$E1.C2$ to $E5.C2$	Internal event 1 to 5 Configuration 2	Digits are called as 1st digit, 2nd digit, 3rd digit and 4th digit from the right end digit.	0000	0
	1st digit: Direct/Reverse	0: Direct 1: Reverse	0	
	2nd digit: Stand-by	0: None 1: Standby 2: Standby + Standby at SP change	0	
	3rd digit: EVENT state at READY	0: Continue 1: Forced OFF	0	
	4th digit: Undefined	0	0	
$E1.C3$ to $E5.C3$	Internal event 1 to 5 Configuration 3	Digits are called as 1st digit, 2nd digit, 3rd digit and 4th digit from the right end digit.	0000	2
	1st digit: Alarm OR	0: No event 1: Alarm direct + OR operation 2: Alarm direct + AND operation 3: Alarm reverse + OR operation 4: Alarm reverse + AND operation	0	
	2nd digit: Special OFF	0: As normal execution 1: Event OFF at the event setting value (main)=0	0	
	3rd digit: Delay time unit	0: 0.1s 1: 1s 2: 1min	0	
	4th digit: Undefined	0	0	

■ DI assignment bank

Bank selection: d'

Display	Item	Contents	Initial value	User level
$d1.1$ to $d3.1$	Internal contact 1 to 3 Operation type	0: No function 1: LSP group selection (0/+1) 2: LSP group selection (0/+2) 3: LSP group selection (0/+4) 4: Invalid 5: Invalid 6: Invalid 7: RUN/READY selection 8: AUTO/MANUAL selection 9: Invalid 10: AT Stop/Start 11: ST Disabled/Enabled 12: Control action direct/reverse selection (As per setting/opposite operation of setting) 13: SP ramp Enabled/Disabled 14: PV hold (No-hold/Hold) 15: PV maximum value hold (No-hold/Hold) 16: PV minimum value hold (No-hold/Hold) 17: Timer Stop/Start 18: Release of all DO latches (Continue/Release) 19: Invalid 20: Invalid	0	0
$d1.2$ to $d3.2$	Internal contact 1 to 3 Input bit operation	0: Disabled. (Input of default) 1: Function 1 ((A and B) or (C and D)) 2: Function 2 ((A or B) and (C or D)) 3: Function 3 (A or B or C or D) 4: Function 4 (A and B and C and D)	0	2

Display	Item	Contents	Initial value	User level
$d1.3$ to $d3.3$	Internal contact 1 to 3 Input assignment A	0: Normally open (OFF, 0) 1: Normally close (ON, 1) 2: DI1 3: DI2 4 to 9: Undefined 10: Internal event 1 11: Internal event 2 12: Internal event 3 13: Internal event 4 14: Internal event 5 15 to 17: Undefined 18: Communication DI1 19: Communication DI2 20: Communication DI3 21: Communication DI4 22: MANUAL mode 23: READY mode 24: Undefined 25: During AT execution 26: During SP ramp 27: Undefined	2 to 4	2
$d1.4$ to $d3.4$	Internal contact 1 to 3 Input assignment B	12: Internal event 3 13: Internal event 4 14: Internal event 5 15 to 17: Undefined 18: Communication DI1 19: Communication DI2 20: Communication DI3 21: Communication DI4 22: MANUAL mode 23: READY mode 24: Undefined 25: During AT execution 26: During SP ramp 27: Undefined	0	2
$d1.5$ to $d3.5$	Internal contact 1 to 3 Input assignment C	28: Alarm is enabled. 29: PV alarm is enabled. 30: Undefined 31: Mode key function selection status 32: Event output 1 status 33: Control output 1 status	0	2
$d1.6$ to $d3.6$	Internal contact 1 to 3 Input assignment D	28: Alarm is enabled. 29: PV alarm is enabled. 30: Undefined 31: Mode key function selection status 32: Event output 1 status 33: Control output 1 status	0	2
$d1.7$ to $d3.7$	Internal contact 1 to 3 Polarity A to D	Digits are called as 1st digit, 2nd digit, 3rd digit and 4th digit from the right end digit.	0000	2
	1st digit: Polarity A (Polarity of input assignment A)	0: Direct 1: Reverse	0	
	2nd digit: Polarity B (Polarity of input assignment B)	0	0	
	3rd digit: Polarity C (Polarity of input assignment C)	0	0	
	4th digit: Polarity D (Polarity of input assignment D)	0	0	
$d1.8$ to $d3.8$	Internal contact 1 to 3 Polarity	0: Direct 1: Reverse	0	2
$d1.9$ to $d3.9$	Internal contact 1 to 3 No. assignment	0: Every internal event 1 to 5: Internal event numbers	0	2

■ DO assignment bank

Bank selection: $d'o$

Display	Item	Contents	Initial value	User level
$o1.1$ to $o2.1$ $Ev.1.1$ to $Ev.3.1$	Control output 1 to 2, event output 1 to 3 operation type	0: Input of default 1: MV1 (ON/OFF control output, time proportional output, heat-side proportional output of heat/cool control) 2: MV2 (cool-side proportional output of heat/cool control) 3: Function 1 ((A and B) or (C and D)) 4: Function 2 ((A or B) and (C or D)) 5: Function 3 (A or B or C or D) 6: Function 4 (A and B and C and D)	0	2
$o1.2$ to $o2.2$ $Ev.1.2$ to $Ev.3.2$	Control output 1 to 2, event output 1 to 3 output assignment A	0: Normally open (OFF, 0) 1: Normally close (ON, 1) 2: Internal event 1 3: Internal event 2 4: Internal event 3 5: Internal event 4 6: Internal event 5 7 to 13: Undefined 14: MV1 15: MV2 16 to 17: Undefined 18: DI1 19: DI2 20 to 25: Undefined 26: Internal contact 1 27: Internal contact 2 28: Internal contact 3 29 to 33: Undefined	14 to 15 or 2 to 3	2
$o1.3$ to $o2.3$ $Ev.1.3$ to $Ev.3.3$	Control output 1 to 2, event output 1 to 3 output assignment B	34: Communication DI1 35: Communication DI2 36: Communication DI3 37: Communication DI4 38: MANUAL mode 39: READY mode 40: Invalid 41: During AT execution 42: During SP ramp 43: Undefined 44: Alarm is enabled. 45: PV alarm is enabled. 46: Undefined 47: mode key function selection status 48: Event output 1 status 49: Control output 1 status	0	2
$o1.4$ to $o2.4$ $Ev.1.4$ to $Ev.3.4$	Control output 1 to 2, event output 1 to 3 output assignment C	34: Communication DI1 35: Communication DI2 36: Communication DI3 37: Communication DI4 38: MANUAL mode 39: READY mode 40: Invalid 41: During AT execution 42: During SP ramp 43: Undefined 44: Alarm is enabled. 45: PV alarm is enabled. 46: Undefined 47: mode key function selection status 48: Event output 1 status 49: Control output 1 status	0	2
$o1.5$ to $o2.5$ $Ev.1.5$ to $Ev.3.5$	Control output 1 to 2, event output 1 to 3 output assignment D	34: Communication DI1 35: Communication DI2 36: Communication DI3 37: Communication DI4 38: MANUAL mode 39: READY mode 40: Invalid 41: During AT execution 42: During SP ramp 43: Undefined 44: Alarm is enabled. 45: PV alarm is enabled. 46: Undefined 47: mode key function selection status 48: Event output 1 status 49: Control output 1 status	0	2

Display	Item	Contents	Initial value	User level
$o1.6$ to $o2.6$ $Ev.1.6$ to $Ev.3.6$	Control output 1 to 2, event output 1 to 2 Polarity A to D	Digits are called as 1st digit, 2nd digit, 3rd digit and 4th digit from the right end digit.	0000	2
	1st digit: Polarity A	0: Direct 1: Reverse	0	
	2nd digit: Polarity B	0: Direct 1: Reverse	0	
	3rd digit: Polarity C	0: Direct 1: Reverse	0	
	4th digit: Polarity D	0: Direct 1: Reverse	0	
$o1.7$ to $o2.7$ $Ev.1.7$ to $Ev.3.7$	Control output 1 to 2, event output 1 to 3 Polarity	0: Direct 1: Reverse	0	2
$o1.8$ to $o2.8$ $Ev.1.8$ to $Ev.3.8$	Control output 1 to 2, event output 1 to 3 Latch	0: Disabled 1: Enabled (Latch at ON) 2: Enabled (Latch at OFF, except at the time of initialization after power ON)	0	2

■ User function bank

Bank selection: UF

Display	Item	Contents	Initial value	User level
$UF-1$	User function definition 1	This is the display in upper display. The setup exception is as follows: ---- : Yet to be registered.	----	1
$UF-2$	User function definition 2	$P-..$: Proportional band of the PID group in use $I-..$: Integration time of the PID group in use $d'-..$: Derivative time of the PID group in use $r-E-..$: Manual reset of the PID group in use $oL-..$: MV low limit of the PID group in use $oH-..$: MV high limit of the PID group in use $P-..C$: Cool-side proportional band of the PID group in use $I-..C$: Cool-side integration time of the PID group in use $d'-..C$: Cool-side derivative time of the PID group in use	----	1
$UF-3$	User function definition 3	$r-E-..$: Manual reset of the PID group in use $oL-..$: MV low limit of the PID group in use $oH-..$: MV high limit of the PID group in use $P-..C$: Cool-side proportional band of the PID group in use $I-..C$: Cool-side integration time of the PID group in use $d'-..C$: Cool-side derivative time of the PID group in use	----	1
$UF-4$	User function definition 4	$oL-..$: MV low limit of the PID group in use $oH-..$: MV high limit of the PID group in use $P-..C$: Cool-side proportional band of the PID group in use $I-..C$: Cool-side integration time of the PID group in use $d'-..C$: Cool-side derivative time of the PID group in use	----	1
$UF-5$	User function definition 5	$I-..C$: Cool-side integration time of the PID group in use $d'-..C$: Cool-side derivative time of the PID group in use	----	1
$UF-6$	User function definition 6	$d'-..C$: Cool-side derivative time of the PID group in use $oL-..C$: Cool-side MV low limit of the PID group in use	----	1
$UF-7$	User function definition 7	$oL-..C$: Cool-side MV low limit of the PID group in use $oH-..C$: Cool-side of MV high limit of the PID group in use	----	1
$UF-8$	User function definition 8	$oH-..C$: Cool-side of MV high limit of the PID group in use	----	1

■ Lock bank

Bank selection: LoC

Display	Item	Contents	Initial value	User level
LoC	Key lock	0: All settings are enabled. 1: Mode, event, operation display, SP, UF, lock, manual MV, and mode key can be set. 2: Operation display, SP, UF, lock, manual MV, and mode key can be set. 3: UF, lock, manual MV, and mode key can be set.	0	0
C, LoC	Communication lock	0: RS-485 communication read/write is enabled. 1: RS-485 communication read/write is disabled.	0	2
L, LoC	Loader lock	0: Loader communication read/write is enabled. 1: Loader communication read/write is disabled.	0	2
$PRSS$	Password display	0 to 15 5: Password 1A to 2B display	0	0
$PS1R$	Password 1A	0000 to FFFF (hexadecimal value)	0000	0
$PS2R$	Password 2A	0000 to FFFF (hexadecimal value)	0000	0
$PS1B$	Password 1B	0000 to FFFF (hexadecimal value)	0000	0
$PS2B$	Password 2B	0000 to FFFF (hexadecimal value)	0000	0

■ Instrument information bank

Bank selection: Id

Display	Item	Contents	Initial value	User level
$Id01$	Controller type No.	0 fixed	0	2
$Id02$	ROM version 1	XX.XX (2 digits after decimal point)	-	2
$Id03$	ROM version 2	XX.XX (2 digits after decimal point)	-	2
$Id04$	SLP support Information		-	2
$Id05$	EST support version		-	2
$Id06$	Manufacturing date code (year)	Year - 2000 Ex.: "3" means the year 2003.	-	2
$Id07$	Manufacturing date code (month, day)	Month + Day : 100 Ex.: "12.01" means the 1st day of December	-	2
$Id08$	Serial No.		-	2

YAMATAKE

Specifications are subject to change without notice.

Yamatake Corporation
Advanced Automation Company

1-12-2 Kawana Fujisawa
Kanagawa 251-8522 Japan

URL: <http://www.yamatake.com>

Printed in Japan.
1st Edition: Issued in Feb. 2003 (A)
10th Edition: Issued in July 2006 (W)

Printed on recycled paper. (05)