



186-3

**Honeywell**

**SE-90 Series**  
**Digital Temperature Controller**      **Product Manual**

CONTENTS

- 1. DIMENSIONS AND PANEL CUTOUT DIMENSIONS
- 2. INSTALLATION
- 3. WIRING
- 4. FRONT PANEL LABELS
- 5. MAIN SETTINGS
- 6. SET SP
- 7. TROUBLE SHOOTING
- 8. SPECIFICATIONS



**Honeywell**

# SE-90 Series Digital Temperature Controller

# TABLE OF CONTENTS

## CONTENTS

	Page
1. DIMENSIONS AND PANEL CUTOUT DIMENSIONS	2
2. INSTALLATION	3
3. WIRING	4
4. FRONT PANEL LAYOUT	5
5. MAIN SETTINGS AND PARAMETER SETTINGS	6
6. SET UP	8
7. TROUBLESHOOTING	12
8. SPECIFICATIONS	13

# 1. DIMENSIONS AND PANEL CUTOUT DIMENSIONS

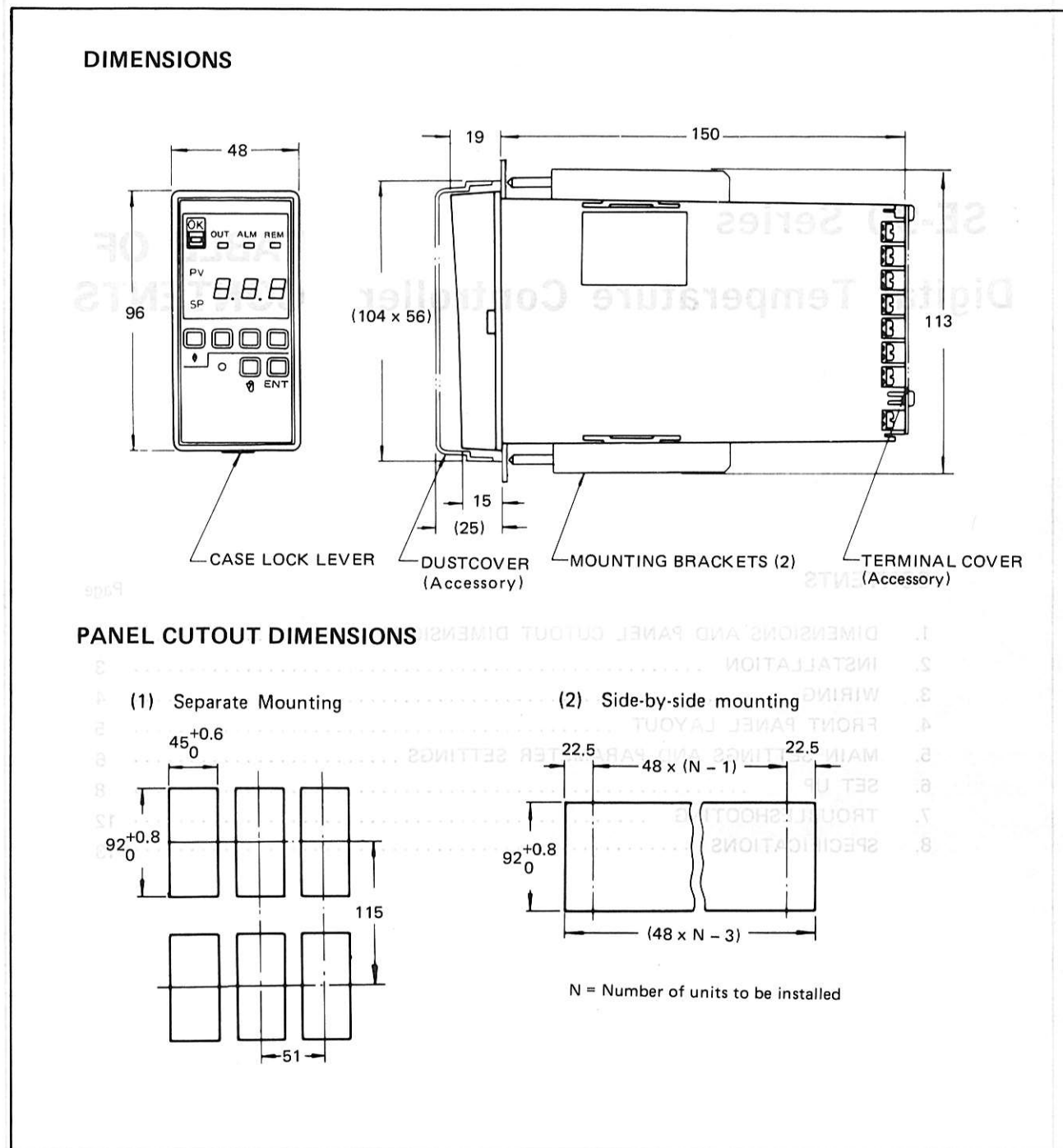

Fig. 1

# 2. INSTALLATION

## 1. INSTALLATION LOCATION LIMITATIONS

When installing, please observe the following conditions:

- (1) Physical Conditions
  - Ambient Temperature: 0 – 50°C
  - Humidity Range: 90% RH max. at 40°C
  - Vibration Resistance: Less than 0.5 G (10 to 60Hz)
  - Shock Resistance: Less than 50 G
- (2) Environmental Conditions
  - ① Avoid installation in places where corrosion or an explosion might occur.
  - ② When using the controller in a place where there are dust or grease particles, use it with the dustcover. (Part No. N-3173)

NOTE: When installing side-by-side, it is not possible to use the dustcover.
- (3) Electrical Noise
 

As far as possible, keep the controller away from: high capacity electromagnetic switches, electrical devices generating strong high frequency waves, and SCR units.

## 2. INSTALLATION METHOD

- (1) Separate Mounting (Fig. 2)
 

Install the case into the panel opening, tighten screws on the mounting brackets (2), until the tip of the screws are secured. As the mounting brackets are ratchet type, there is no need to worry about over-tightening.
- (2) Side-by-Side Mounting (Fig. 4)
 

After fixing the optional close-mounting brackets (part No. N-3172) in the controller side, and terminal side, put the controllers in the panel cutout and fasten to the panel tightly using the mounting brackets.

### Panel installation

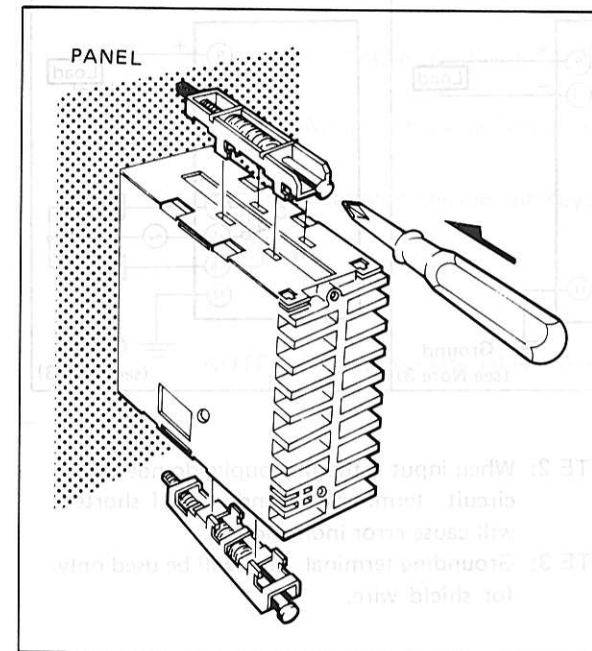

Fig. 2

### Dust cover attachment

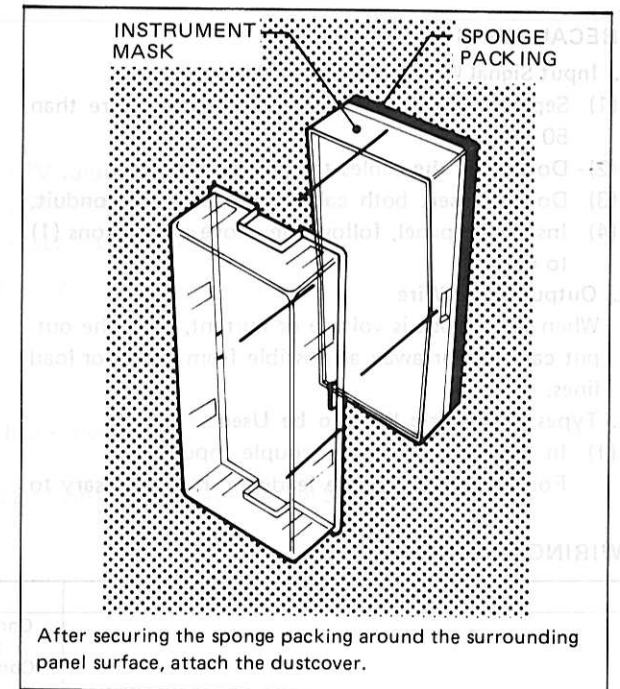

Fig. 3

### Side-by-side mounting

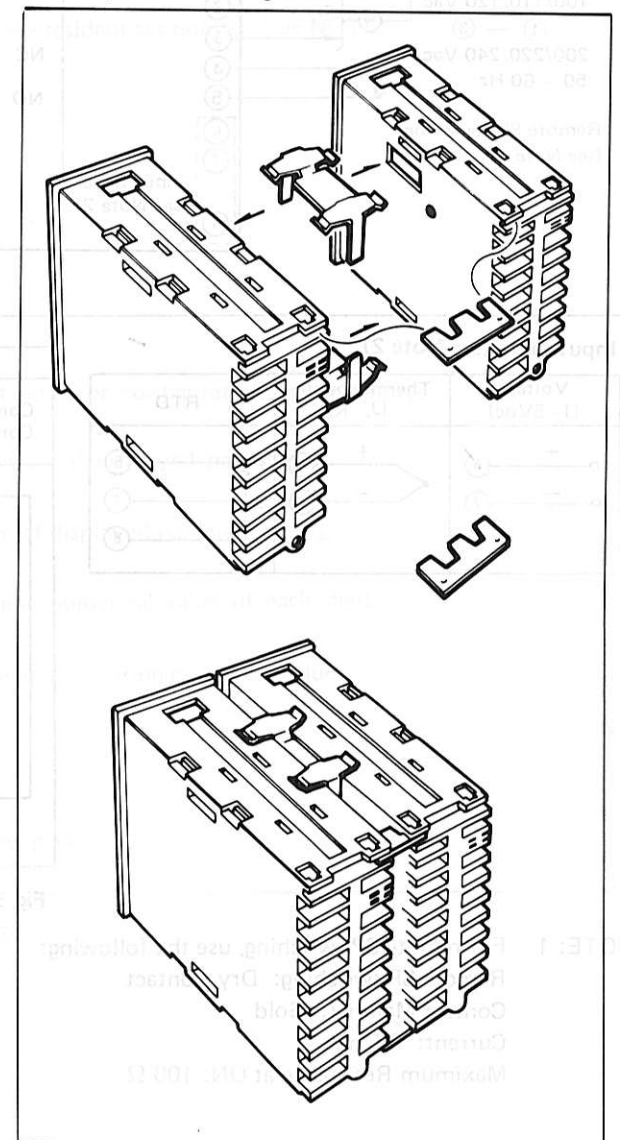

Fig. 4

# 3. WIRING

## PRECAUTIONS

### 1. Input Signal Wiring and Power Wiring

- (1) Separate signal and power wiring by more than 50 cm.
- (2) Do not tie the cables together in a bundle.
- (3) Do not insert both cables into the same conduit.
- (4) Inside the panel, follow the above precautions (1) to (3).

### 2. Output Signal Wire

When the output is voltage or current, keep the output cable as far away as possible from power or load lines.

### 3. Types of Electric Wire to be Used

- (1) In the Case of Thermocouple input:  
For the thermocouple leadwire, it is necessary to

use thermocouple compensation wire.

- (2) In the case of Pt Resistance Bulb (RTD) Input:  
The three leadwires must be of same gauge and length.

### 4. Wiring

- (1) For solderless terminals, use a compatible M3.5 (metric) screw.
- (2) Use the wiring diagram which corresponds to the controller model number. After completion of wiring, check for possible errors.
- (3) No power supply switch or fuse is provided in this unit. If required, one should be provided externally.

## WIRING DIAGRAM

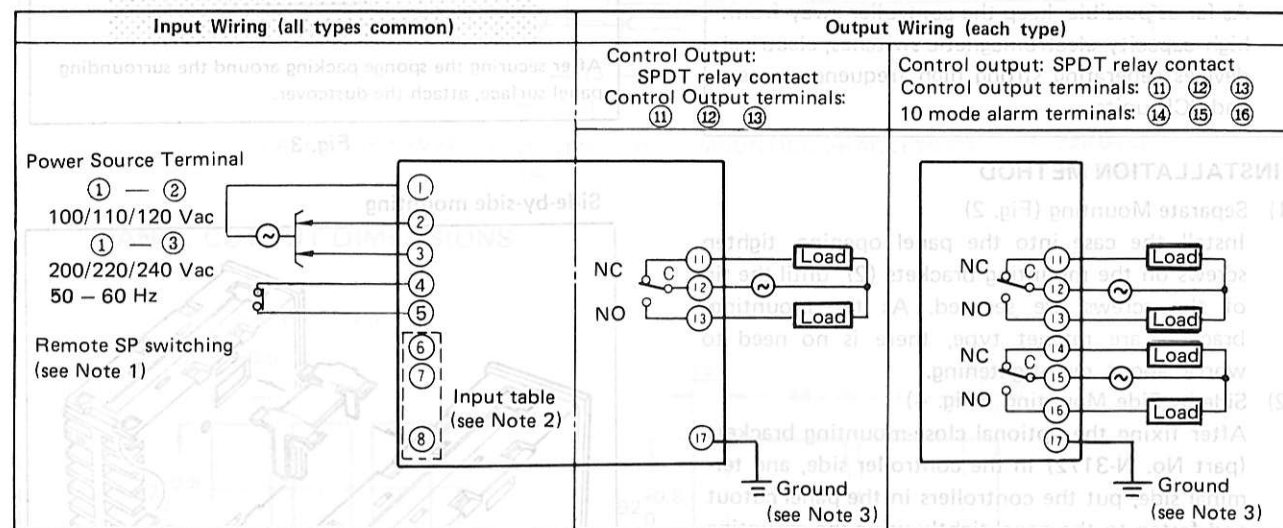

### Input table (see Note 2)

Voltage (1-5Vdc)	Thermocouple (J, K)	RTD
<p>+</p> <p>⑥</p> <p>-</p> <p>⑦</p>	<p>+</p> <p>⑥</p> <p>-</p> <p>⑦</p>	<p>A</p> <p>⑥</p> <p>B</p> <p>⑦</p> <p>C</p> <p>⑧</p>

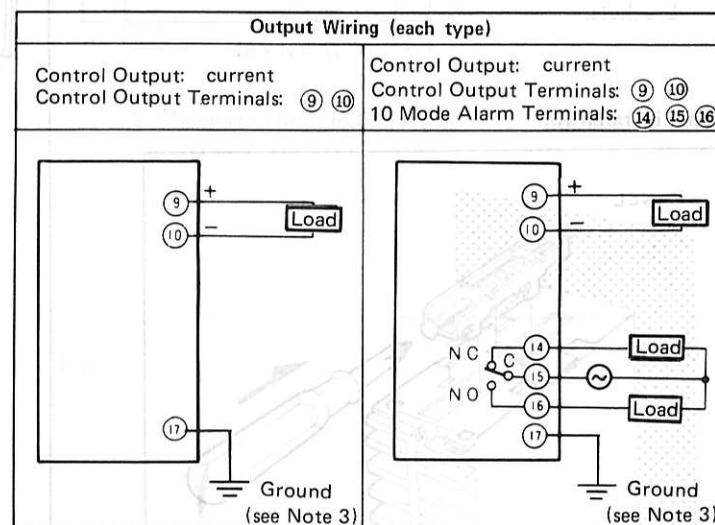

Fig. 5

NOTE: 1 For remote SP switching, use the following:  
Remote SP switching: Dry Contact  
Contact Material: Gold  
Current: 0.5 mA  
Maximum Resistance at ON: 100 Ω

NOTE 2: When input is thermocouple, do not short-circuit terminals ⑦ and ⑧. If shorted, will cause error indication.

NOTE 3: Grounding terminal ⑰ will be used only for shield wire.

# 4. FRONT PANEL LAYOUT

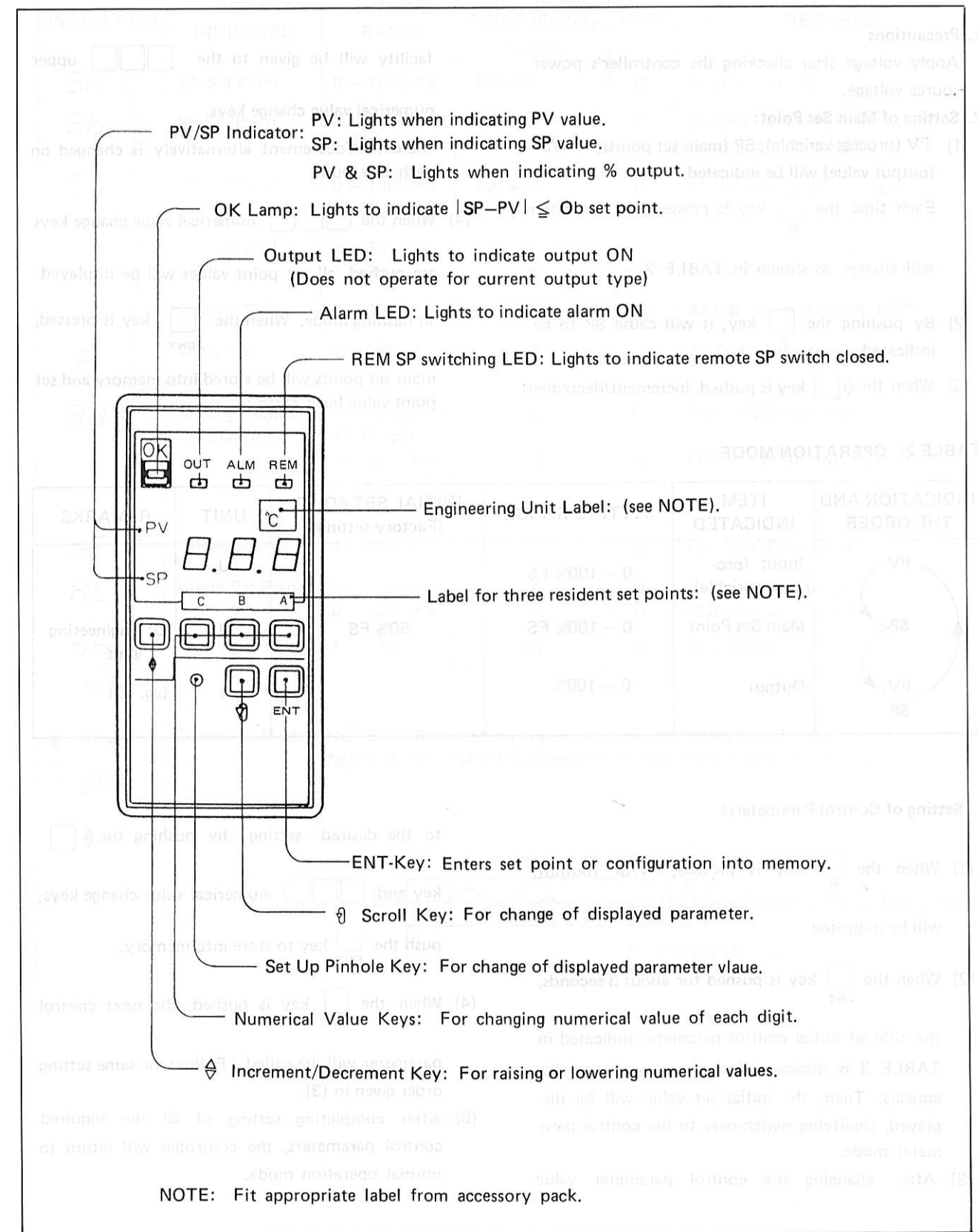

Fig. 6

# 5. MAIN SETTINGS AND PARAMETER SETTINGS

## 1. Precautions

Apply voltage after checking the controller's power source voltage.

facility will be given to the    upper numerical value change keys.

## 2. Setting of Main Set Point:

(1) PV (process variable), SP (main set point), PV/SP (output value) will be indicated.

Increment/decrement alternatively is changed on each key push.

Each time the  key is pressed, the indication

(4) When the    numerical value change keys

will change, as shown in TABLE 2.

are pushed, all set point values will be displayed

(2) By pushing the  key, it will cause SP to be indicated.

in flashing mode. When the  ENT key is pressed,

(3) When the  key is pushed, increment/decrement

main set points will be stored into memory and set point value burn steady.

TABLE 2: OPERATION MODE

INDICATION AND THE ORDER	ITEM INDICATED	SETTING RANGE	INITIAL SET POINT (Factory setting)	UNIT	REMARKS
	Input (process variable)	0 – 100% FS		U	
	Main Set Point	0 – 100% FS	50% FS	U	U: Engineering Unit
	Output	0 – 100%		%	(eg. °C)

## 3. Setting of Control Parameters:

(1) When the  key is pressed, PV/SP (output) will be indicated.

to the desired setting by pushing the  key and    numerical value change keys, push the  ENT key to store into memory.

(2) When the  ENT key is pushed for about 3 seconds,

(4) When the  key is pushed, the next control

the title of initial control parameter indicated in TABLE 3 is displayed for two seconds and disappears. Then, the initial set value will be displayed, signifying switch-over to the control parameter mode.

parameter will be called. Follow the same setting order given in (3).

(3) After changing the control parameter value

(5) After completing setting of all the required control parameters, the controller will return to normal operation mode.

TABLE 3: CONTROL PARAMETERS

INDICATION	ITEM INDICATED	SETTING RANGE	INITIAL SET POINT (Factory setting)	UNIT	REMARKS
SA	SA Set Point	0 – 100% FS	50% FS	U	First resident SP.
SB	SB Set Point	0 – 100% FS	0% FS	U	Second resident SP or lower setting limit. (see NOTE 1)
SC	SC Set Point	0 – 100% FS	100% FS	U	Third resident SP or upper setting limit (see NOTE 1)
P	Proportional Band	0 – 39 1 – 39	39 39	%FS %FS	At P=0, ON-OFF control Current output.
I	Integral Time	0 – 300	0	Sec.	At I=0, integral action, OFF
D	Derivative Time	0 – 300	0	Sec.	At D=0 derivative action, OFF
Ad	Main Set Point Manual reset	-1/10 span to +1/10 span -1/2 to +1/2 proportional band	0 0	U U	For ON-OFF control For time proportioning control
dF	Differential	1 – 100	10	U	For ON-OFF control
AL	Alarm Set Point	0 – 1/2 span 0 – 100% FS	0 0	U U	Alarm mode # 0 to 7 Alarm mode # 8 to 9
ob	OK Lamp	1 – 100	10	U	(See NOTE 2.)
	Operation Mode	NOTE 1: When setting upper and lower setting limits, SB < SC. NOTE 2: Control performance can be confirmed with the OK lamp.			

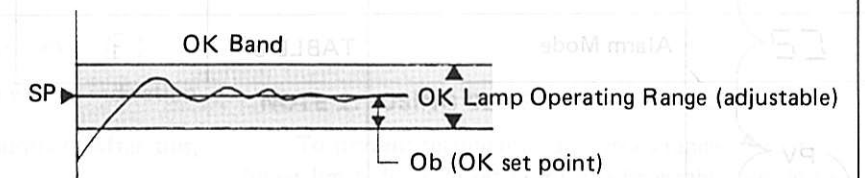

# 6. SET UP

When initial specifications are to be altered, set up will be necessary. Set up permits the following:

- (1) Change of actuation and range.
- (2) Change of direct/reverse output action.
- (3) Change of set point mode.
- (4) Change of alarm mode.

### 2. Precautions for Set Up

- (1) When the chassis is to be removed from its case, disconnect the controller's power supply.
- (2) Do not get the instrument's pcb edge connectors dirty.
- (3) Remember that if set up is performed while the instrument is in operation, output will instantaneously drop to zero, upon completion.

### 3. Order for Shifting Over to Set Up Mode

- (1) Set up can be performed when any of the PV, SP, PV/SP operation modes are indicated.
- (2) Lightly push the  $\bigcirc$  pinhole key with a pencil, etc.,

TABLE 4: SET UP MODE

INDICATION AND THE ORDER (NOTE)	ITEM INDICATED	SETTING RANGE	INITIAL SET POINT (Factory set)	UNIT
[1]	Input Type/Range	TABLE 5	As Specified	U
	Direct/Reverse Output Action	TABLE 6	0	
	Set Point Mode	TABLE 7	0	
[2]	Alarm Mode	TABLE 8	1	
PV SP PV/SP	Operation Mode			

for 3 seconds.

[1] is indicated for 2 seconds and disappears.

The initial Input Type number will then be indicated.

- (3) Each time the  $\square$  key is pushed, all modes in the order given in TABLE 4 will be displayed.
- (4) When performing set up, the  $\diamond$   $\square$  key will not function. Perform digit change from 0 to 9 using the appropriate  $\square$  keys only.
- (5) When set up is completed, the controller returns to normal operation mode.

### 3-1 CHANGES OF INPUT TYPE/RANGE, DIRECT/REVERSE OUTPUT ACTION, AND SET POINT MODE

(1) Changing Input Type and Range (see TABLE 5)

① After disconnecting the controller's power source, select the type of input by setting the DIP switches. Replace in the case, and apply power.

② Push the set up  $\bigcirc$  pinhole key. [1] is displayed for 2 seconds, followed by the initial range number. After this, input the desired range number in the first digit by pressing the appropriate  $\square$  numerical value change key. Push the  $\square$  key to store in memory. (The microcomputer will automatically perform zero and span adjustment.)

(2) Direct/Reverse Action Output Change (see Table 6)

Push the set up  $\bigcirc$  pinhole key [1] is displayed for two seconds, followed by indication of the initial output action number. After this, input the desired output action number in the second digit by pressing the appropriate  $\square$  numerical value change key. Push the  $\square$  key to store in memory.

(3) Changing the Set Point Mode (see TABLE 7)

Push the set up  $\bigcirc$  pinhole key. [1] is displayed for two seconds, followed by indication of the initial set point mode number. After this, input the desired set point mode number in the third digit by pressing the appropriate  $\square$  numerical value setting key. Push the  $\square$  key to store in memory.

(4) When two or all to the above items (1) - (3) are to be performed at the same time, set all of the digits,

one-by-one, after [1] indication. By pushing the  $\square$  key once, all changes will be stored in memory.

Settings can be input in any order.

### NOTE: 1 USING THREE RESIDENT SET POINTS:

(1) Local Selection

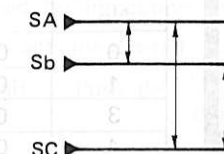

Input the 3 set points SA, Sb and SC (see Table 3) as shown in control parameter adjustment.

By pushing the  $\square$   $\square$   $\square$  keys, the specific set point is made active.

(2) Remote Selection

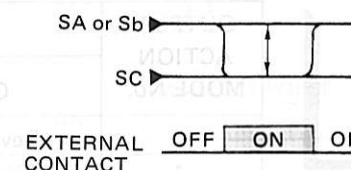

Set the 3 set points SA, Sb, SC (see Table 3).

Two setting changes can be accomplished.

If external terminals ④-⑤ are open, then SA or Sb  $\leftarrow$  SC.

If external terminals ④-⑤ are closed, then SA or Sb  $\rightarrow$  SC.

In this case, the set point cannot be changed by pushing  $\square$   $\square$   $\square$  keys.

### NOTE 2: USING SET POINT LIMITING:

To prevent setting into dangerous ranges, upper and lower limits for safe set point can be established. In this case, Sb will serve as the lower limit set point and SC as the upper limit set point.



### INDICATOR

**TABLE 5: RANGE MODE NUMBER AND DIP SWITCH POSITION**

① RANGE MODE No.	INPUT TYPE/RANGE	RANGE CODE No.	② DIP SWITCH POSITION									
			1	2	3	4	5	6	7	8	9	10
0	0 – 400°C J	J04	1	0	0	0	0	1	1	0	0	1
1	0 – 400°C K	K04	1	0	0	0	0	1	1	0	0	1
3	0 – 999°C K	K15	1	0	0	0	0	1	1	0	0	0
4	0 – 100°C DIN Pt 100Ω(IEC)	H05	1	0	1	1	0	0	0	1	1	0
6	- 50 to 200°C DIN Pt 100Ω(IEC)	H04	0	0	1	1	0	0	0	1	1	0
8	0 – 400°C DIN Pt 100Ω(IEC)	H06	1	0	1	1	0	1	1	0	0	0
9	1 – 5Vdc	V01	1	0	1	1	0	1	1	0	0	0

Remarks: ① Specified range no. is set at factory ② 1 : ON side 0 : OFF side

**TABLE 6: OUTPUT ACTION**

OUTPUT ACTION MODE No.	OUTPUT TYPE	
	CURRENT	RELAY CONTACT/CYCLE TIME
0	Reverse Action	Reverse Action 40 sec.
1	Direct Action	Direct Action 40 sec.
2	—	Reverse Action 20 sec.
3	—	Direct Action 20 sec.

Remarks: No. 0 is set at factory.

**TABLE 7: SET POINT MODE**

SET POINT MODE No.	SET POINT MODE
0	Does not lock set point
1	Locks set point
2	Set Point limiting
3	3 resident set Points

Remarks: Nos. 2 & 3 can not be used at the same time. No. 0 is set at factory.

### INPUT TYPE CHANGE DIP SWITCH

Facing the controller chassis when it is removed from its case, this DIP switch will be found on the right hand side.

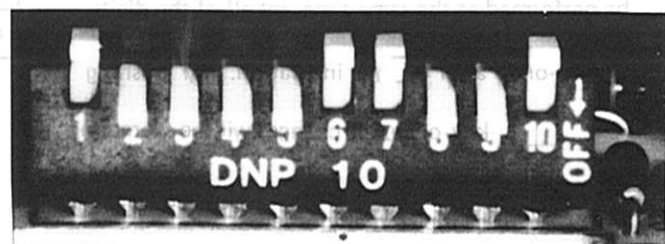

PHOTO 1

### 3-2 CHANGE OF ALARM MODE

#### CAUTION:

When changing the alarm mode and setting the alarm point; since entering erroneous information may easily cause an accident, all input and output terminals other than the controller's power supply terminals ① – ② or ① – ③ should be disconnected. Once the setting and change are completed, return to the original wiring in accordance with the wiring diagram.

#### Change of Alarm Mode (TABLE 8)

Push the  key. **02** is displayed for two seconds, followed by indication of the initial alarm mode number. Set the desired alarm mode number in the first digit. Push the  key to store in memory.

### INDICATOR

**TABLE 8: ALARM MODE SELECTION GUIDE**

MODE No.	ALARM MODE	ACTION
		When relay is ON: ⑮ - ⑭ are open and ⑮ - ⑯ closed
0	Low Deviation Alarm	ALARM SP MAIN SET POINT ON OFF Differential
1	High Deviation Alarm	MAIN SET POINT ALARM SP ON OFF
2	High and low Deviation Alarm	ALARM BAND MAIN SET POINT ALARM BAND ON OFF
3	Low Deviation Alarm with Stand-by Sequence*	ALARM SP MAIN SET POINT ON OFF
4	High/Low Deviation Alarm with Standby Sequence*	ALARM BAND MAIN SET POINT ALARM BAND ON OFF
5	High/Low Deviation Alarm, NC Contact Output	ALARM BAND MAIN SET POINT ALARM BAND ON OFF
6	Low Deviation Alarm, NC Contact Output	ALARM SP MAIN SET POINT ON OFF
7	High Deviation Alarm NC Contact Output	MAIN SET POINT ALARM SP ON OFF
8	PV Low Alarm	ALARM SP ON OFF
9	PV High Alarm	ALARM SP ON OFF

Remarks: Factory set at no. 1.

\*With stand-by sequence.

- When initially operating, if actual temperature is lower than the lower limit, the alarm will not operate.
- When the temperature rises above the lower limit, and then the temperature falls back once below the lower limit, the alarm will operate.

# 7. TROUBLESHOOTING

## 1. DETECTION OF INPUT ABNORMALITY

When input becomes abnormal, **Er0** will be indicated.

- (1) When the input value is less than -15% FS or over 115% FS, **Er0** will be indicated.  
Control action will continue to operate.

- (2) When the thermocouple is open circuit, **Er0** will be indicated. (Upscale burnout)

## 2. SELF-DIAGNOSTIC FUNCTION

When an error is detected, **Er1** will be indicated. The self-diagnostic function will perform a data check of control parameters, etc.

When **Er1** is indicated;

- (1) Confirm data in the order of set up → control parameter → set up.
- (2) If the indication is different from the initial data, enter the correct data.
- (3) Finally, disconnect the controller's power source, or go to the set up mode, and cause it to advance

and return to initial condition.

At this point, if **Er1** disappears, the controller is operating normally. If **Er1** continues to be indicated, contact Honeywell, or the distributor from which the controller was purchased.

Alarm No.	Alarm Name	Alarm Description	Alarm Action
1	High and low Deviation Alarm	High and low Deviation Alarm	ON/OFF
2	Low Deviation Alarm with Standby Sequence	Low Deviation Alarm with Standby Sequence	ON/OFF
3	High/Low Deviation Alarm, NC Contact Output	High/Low Deviation Alarm, NC Contact Output	ON/OFF
4	Low Deviation Alarm, NC Contact Output	Low Deviation Alarm, NC Contact Output	ON/OFF
5	High Deviation Alarm, NC Contact Output	High Deviation Alarm, NC Contact Output	ON/OFF
6	PV Low Alarm	PV Low Alarm	ON/OFF
7	PV High Alarm	PV High Alarm	ON/OFF

# 8. SPECIFICATIONS

Honeywell

- Operating temperature:** 0 to 50°C
- Storage temperature:** -20°C to +60°C
- Power consumption:** 6 watt maximum
- Accuracy:** 0.5% of span at 20°C (typical)
- Current output:** 4-20mA in 500 ohm maximum
- Relay output:** SPDT contacts (5A 250Vac resistive load)
- Sensor protection:** Upscale (Thermocouple only)
- Allowable wiring resistance:**
  - less than 160 ohms for thermocouple
  - less than 4 ohms per leg (balanced) for Pt100
- Auxiliary parts**
  - Dust cover: N3173
  - Terminal cover: N3171